

DS125BR401A 低功率 12Gbps 4 信道线性中继器，具有均衡功能

1 特性

- 每通道 65mW (典型值) 低功耗，具有将未使用的通道断电的选项
- 线性均衡可在 PCIe 和 SAS 中实现链路协商
- 支持带外 (OOB) 信令
- 高级信号调节 B 侧输入输出 (I/O)
 - 6GHz 时，接收高达 24dB 的 CTLE
 - 发射 (Tx) 去加重 (DE) > 10dB
 - Tx 输出电压：700mV 至 1400mV
- 高级信号调节 A 侧 I/O
 - 6GHz 时，接收高达 10dB 的 CTLE
 - 线性输出驱动
 - 输出电压范围超过 1200mV
 可通过端子选择，EEPROM 或系统管理总线 (SMBus) 接口进行编程
- 单电源电压：2.5V 或 3.3V
- -40°C 至 85°C 的工作温度范围
- 4kV 人体模型 (HBM) 静电放电 (ESD) 额定电压
- 10mm x 5.5mm 54 端子超薄四方扁平无引线 (WQFN) 封装内的直通布局布线

2 应用范围

- SAS/SATA
- PCI Express
- 其它速率高达 12Gbps 的私有接口

3 说明

DS125BR401A 是一款极低功率高性能中继器/转接驱动器，此款器件设计用于支持四条信道，这些信道上有速率高达 12Gbps 的高速接口。B 侧接收器的连续时间线性均衡器 (CTLE) 在 6GHz (12Gbps) 时提供高达 +24dB 的高频增强，并且能够打开一个由于码间干扰 (ISI) (由诸如背板迹线或铜质同轴电缆等互连介质引起) 而完全关闭的输入眼型状态。可编程均衡可在互连通道内的实体布局方面实现最大限度的灵活性。A 侧通道具有一个 10dB 线性均衡器和线性输出驱动器。

A 侧通道有一个与线性输出驱动器配对使用的 3-10dB 可变线性均衡器。当在 SAS-3 和 PCIe GEN-3 应用中运行时，DS125BR401A 保留发射信号特性，从而使主机控制器和端点能够协商发射均衡器系数。这个链路协商协议的透明管理有助于实现系统级互用性和最小延迟。

可通过端子、软件 (SMBus 或 I2C) 来轻松应用这个可配置设置，或者通过外部 EEPROM 来载入此设置。在 EEPROM 模式下，配置信息在加电时被自动载入，这样就免除了对于外部微控制器或软件驱动程序的需要。

器件信息

订货编号	封装	封装尺寸
DS125BR401ANJY	WQFN (48)	10mm x 5.5mm

SAS-3 应用

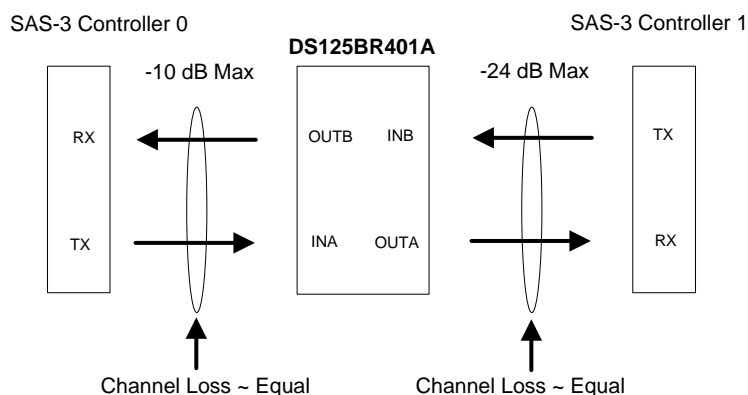

目录

1	特性	1	7.3	Feature Description	14
2	应用范围	1	7.4	Device Functional Modes	14
3	说明	1	7.5	Signal Conditioning Settings	16
4	修订历史记录	2	7.6	Programming	18
5	Terminal Configuration and Functions	3	7.7	Register Maps	25
6	Specifications	6	8	Applications and Implementation	38
6.1	Absolute Maximum Ratings	6	8.1	Application Information	38
6.2	Handling Ratings	6	8.2	Typical Application	39
6.3	Recommended Operating Conditions	6	9	Power Supply Recommendations	42
6.4	Thermal Information	6	10	Layout	43
6.5	Electrical Characteristics	6	10.1	Layout Guidelines	43
6.6	Electrical Characteristics — Serial Management Bus Interface	10	10.2	Layout Example	43
6.7	Timing Requirements Serial Bus Interface	10	11	器件和文档支持	44
6.8	Typical Characteristics	12	11.1	Trademarks	44
7	Detailed Description	13	11.2	Electrostatic Discharge Caution	44
7.1	Overview	13	11.3	Glossary	44
7.2	Functional Block Diagram	13	12	机械封装和可订购信息	44

4 修订历史记录

Changes from Original (September 2013) to Revision A

Page

- | | |
|---|----------|
| • 已更改 从预览改为生产数据文档。 | 1 |
| • 已更改 更改为全新的 TI 数据表标准：已添加处理额定值表和器件以及文档部分。 | 1 |

5 Terminal Configuration and Functions

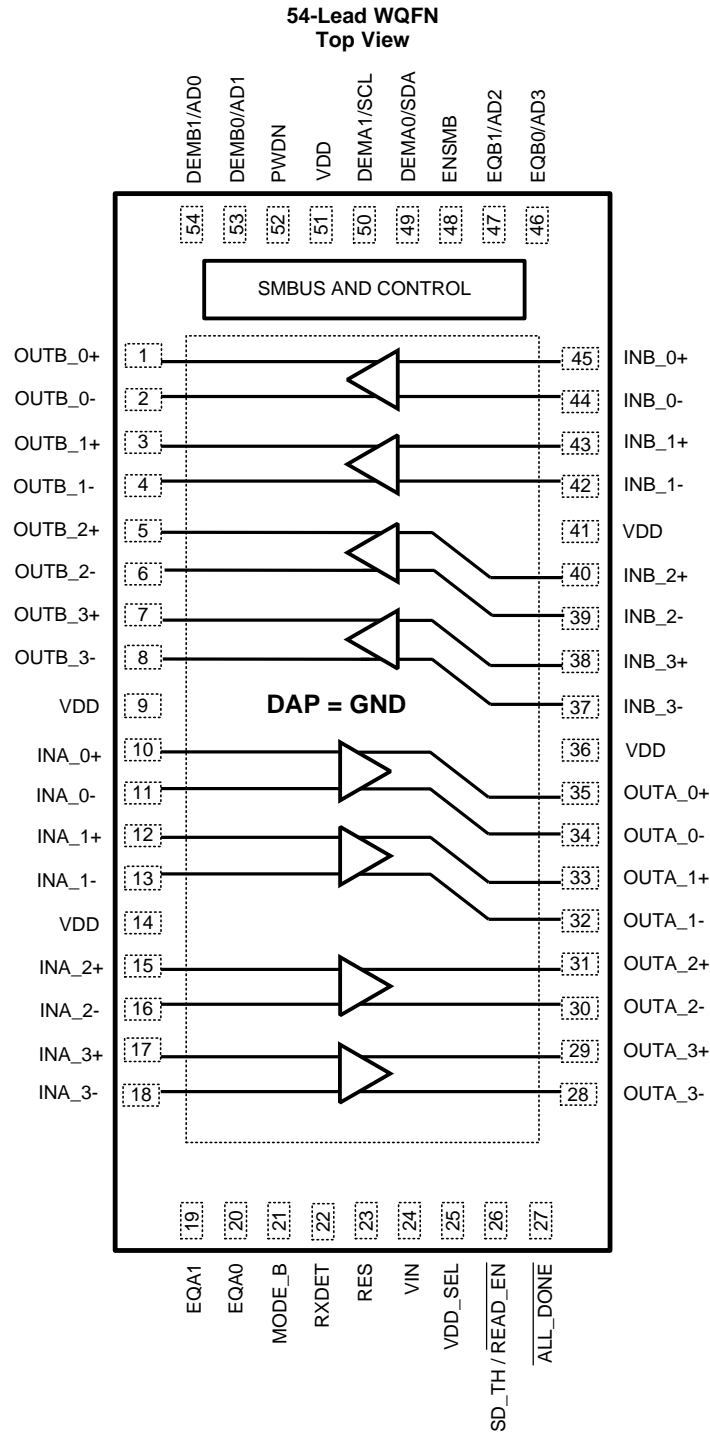

NOTE: Above 54-lead WQFN graphic is a TOP VIEW, looking down through the package.

Terminal Functions⁽¹⁾

TERMINAL NAME	TERMINAL NUMBER	I/O, TYPE	TERMINAL DESCRIPTION
DIFFERENTIAL HIGH SPEED I/O			
INB_0+, INB_0-, INB_1+, INB_1-, INB_2+, INB_2-, INB_3+, INB_3-	45, 44, 43, 42 40, 39, 38, 37	I	Inverting and non-inverting CML differential inputs to the equalizer. On-chip 50Ω termination resistor connects INB_n+ to VDD and INB_n- to VDD when enabled. AC coupling required on high-speed I/O
OUTB_0+, OUTB_0-, OUTB_1+, OUTB_1-, OUTB_2+, OUTB_2-, OUTB_3+, OUTB_3-	1, 2, 3, 4 5, 6, 7, 8	O	Inverting and non-inverting 50Ω driver outputs with de-emphasis. Compatible with AC coupled CML inputs. AC coupling required on high-speed I/O
INA_0+, INA_0-, INA_1+, INA_1-, INA_2+, INA_2-, INA_3+, INA_3-	10, 11, 12, 13 15, 16, 17, 18	I	Inverting and non-inverting CML differential inputs to the equalizer. On-chip 50Ω termination resistor connects INA_n+ to VDD and INA_n- to VDD when enabled. AC coupling required on high-speed I/O
OUTA_0+, OUTA_0-, OUTA_1+, OUTA_1-, OUTA_2+, OUTA_2-, OUTA_3+, OUTA_3-	35, 34, 33, 32 31, 30, 29, 28	O	Inverting and non-inverting 50Ω driver outputs. Compatible with AC coupled CML inputs. AC coupling required on high-speed I/O
CONTROL TERMINALS — SHARED (LVCMOS)			
ENSMB	48	I, LVCMOS	System Management Bus (SMBus) enable Terminal Tie 1kΩ to VDD = Register Access SMBus Slave mode FLOAT = Read External EEPROM (Master SMBUS Mode) Tie 1kΩ to GND = Terminal Mode
ENSMB = 1 (SMBus MODE)			
SCL	50	I, LVCMOS, O, OPEN Drain	ENSMB Master or Slave mode SMBus clock input Terminal is enabled (slave mode). Clock output when loading EEPROM configuration (master mode).
SDA	49	I, LVCMOS, O, OPEN Drain	ENSMB Master or Slave mode The SMBus bidirectional SDA Terminal is enabled. Data input or open drain (pull-down only) output.
AD0-AD3	54, 53, 47, 46	I, LVCMOS	ENSMB Master or Slave mode SMBus Slave Address Inputs. In SMBus mode, these Terminals are the user set SMBus slave address inputs.
READ_EN	26	I, LVCMOS	When using an External EEPROM, a logic low on this terminal starts the load from the external EEPROM
ENSMB = 0 (TERMINAL MODE)			
EQA0, EQA1 EQB0, EQB1	20, 19 46, 47	I, 4-LEVEL, LVCMOS	EQA[1:0] and EQB[1:0] control the level of equalization of the A/B directions. The Terminals are defined as EQx[1:0] only when ENSMB is de-asserted (low). Each of the 4 A/B channels have the same level unless controlled by the SMBus control registers. When ENSMB goes high the SMBus registers provide independent control of each lane. The EQB[1:0] Terminals are converted to SMBus AD2, AD3 inputs. See Table 5 .
DEMB0, DEMB1	53, 54	I, 4-LEVEL, LVCMOS	DEMB[1:0] controls the level of de-emphasis of CHB outputs. The Terminals are defined as DEMB[1:0] only when ENSMB is de-asserted (low). Each of the 4 B channels have the same level unless controlled by the SMBus control registers. When ENSMB goes high the SMBus registers provide independent control of each lane. The DEMB[1:0] Terminals are converted to AD0, AD1 inputs. See Table 7 .
MODE_B	21	I, 4-LEVEL, LVCMOS	MODE_B control Terminal selects operating modes for the INB-OUTB Channels. Tie 1kΩ to GND = GEN 1,2 and SAS 1,2 Float = Auto Mode Select (for PCIe) Tie 20kΩ to GND = SAS-3 and GEN-3 without De-emphasis Tie 1kΩ to VDD = SAS-3 and GEN-3 with De-emphasis See Table 4 .

- (1) LVCMOS inputs without the "Float" conditions must be driven to a logic low or high at all times or operation is not ensured. Input edge rate for LVCMOS/FLOAT inputs must be faster than 50 ns from 10–90%.
For 3.3V mode operation, VIN Terminal input = 3.3V and the logic "1" reference for the 4-level input is 3.3V.
For 2.5V mode operation, VDD Terminal output = 2.5V and the logic "1" reference for the 4-level input is 2.5V.

Terminal Functions⁽¹⁾ (continued)

TERMINAL NAME	TERMINAL NUMBER	I/O, TYPE	TERMINAL DESCRIPTION
DEMA0, DEMA1	49, 50	I, 4-LEVEL, LVCMOS	DEMA[1:0] controls the CHA output amplitude. The Terminals are defined as DEMA[1:0] only when ENSMB is de-asserted (low). Each of the 4 A channels have the same level unless controlled by the SMBus control registers. When ENSMB goes high the SMBus registers provide independent control of each lane and the DEMA[1:0] Terminals are converted to SCL and SDA. See Table 7 .
SD_TH	26	I, 4-LEVEL, LVCMOS	Controls the internal Signal Detect Threshold on the INB-OUTB Channels. For CHB, the signal detect is used to bring the output into and out of IDLE. This allows the OOB signaling to pass with minimal distortion. See Table 3 .
CONTROL TERMINALS — BOTH TERMINAL AND SMBus MODES (LVCMOS)			
RXDET	22	I, 4-LEVEL, LVCMOS	The RXDET Terminal controls the receiver detect function. Depending on the input level, a 50Ω or >50KΩ termination to the power rail is enabled. In SAS/SATA system RXDET should be set to a Logic "1" state to keep the termination always enabled. See Table 2 .
RES	23	I, 4-LEVEL, LVCMOS	Reserved: This input must be left Floating.
VDD_SEL	25	I, FLOAT	Controls the internal regulator Float = 2.5V mode Tie GND = 3.3V mode
PWDN	52	I, LVCMOS	Tie High = Low power - power down Tie GND = Normal Operation See Table 2 .
ALL_DONE	27	O, LVCMOS	Valid Register Load Status Output HIGH = External EEPROM load failed or incomplete LOW = External EEPROM load passed
POWER			
VIN	24	Power	In 3.3V mode, feed 3.3V to VIN In 2.5V mode, leave floating.
VDD	9, 14,36, 41, 51	Power	Power supply Terminals CML/analog 2.5V mode, connect to 2.5V 3.3V mode, connect 0.1 μF cap to each VDD Terminal and GND
GND	DAP	Power	Ground pad (DAP - die attach pad).

6 Specifications

6.1 Absolute Maximum Ratings⁽¹⁾

	MIN	MAX	UNIT
Supply Voltage (VDD - 2.5V)	-0.5	+2.75	V
Supply Voltage (VIN - 3.3V)	-0.5	+4.0	V
LVC MOS Input/Output Voltage	-0.5	+4.0	V
CML Input Voltage	-0.5V to (VDD+0.5)		
CML Input Current	-30	+30	mA

- (1) “Absolute Maximum Ratings” indicate limits beyond which damage to the device may occur, including inoperability and degradation of device reliability and/or performance. Functional operation of the device and/or non-degradation at the Absolute Maximum Ratings or other conditions beyond those indicated in the Recommended Operating Conditions is not implied. The Recommended Operating Conditions indicate conditions at which the device is functional and the device should not be operated beyond such conditions. Absolute Maximum Numbers are ensured for a junction temperature range of -40°C to +125°C. Models are validated to Maximum Operating Voltages only.

6.2 Handling Ratings

		MIN	MAX	UNIT
ESD _{HBM}	HBM, STD - JESD22-A114F		4	kV
ESD _{CDM}	CDM, STD - JESD22-C101-D		1	kV
T _{stg}	Storage Temperature Range	-40	125	°C
T _{solder}	Lead Temperature Range Soldering (4 sec.) ⁽¹⁾		260	°C

- (1) For soldering specifications: See application note [SNOA549](#).

6.3 Recommended Operating Conditions

	MIN	TYP	MAX	UNIT
Supply Voltage (2.5V mode)	2.375	2.5	2.625	V
Supply Voltage (3.3V mode)	3.0	3.3	3.6	V
Ambient Temperature	-40	25	+85	°C
SMBus (SDA, SCL)			3.6	V
Supply Noise up to 50 MHz ⁽¹⁾			100	mVp-p

- (1) Allowed supply noise (mVp-p sine wave) under typical conditions.

6.4 Thermal Information

THERMAL METRIC ⁽¹⁾		DS125BR401A	UNIT
		WQFN	
		54 TERMINALS	
R _{θJA}	Junction-to-ambient thermal resistance	26.6	°C/W
R _{θJctop}	Junction-to-case (top) thermal resistance	10.8	
R _{θJB}	Junction-to-board thermal resistance	4.4	
Ψ _{JT}	Junction-to-top characterization parameter	0.2	
Ψ _{JB}	Junction-to-board characterization parameter	4.3	
R _{θJcbot}	Junction-to-case (bottom) thermal resistance	1.5	

- (1) For more information about traditional and new thermal metrics, see the *IC Package Thermal Metrics* application report, [SPRA953](#).

6.5 Electrical Characteristics

PARAMETER		TEST CONDITIONS	MIN	TYP	MAX	UNIT
POWER						
I _{DD}	Current Consumption	DEM0 = Float, ,DEM1 = Float EQ = 0, VOD = 0.8VP-P, RXDET = 1, PWDN = 0		200	280	mA
	Power Down Current Consumption	PWDN = 1		14	27	mA

Electrical Characteristics (continued)

PARAMETER		TEST CONDITIONS	MIN	TYP	MAX	UNIT
V _{DD}	Integrated LDO Regulator	V _{IN} = 3.0 - 3.6 V	2.375	2.5	2.625	V
LVC MOS / LV TTL DC SPECIFICATIONS						
V _{ih25}	High Level Input Voltage	2.5 V Supply Mode	1.7		V _{DD}	V
V _{ih33}	High Level Input Voltage	3.3 V Supply Mode	1.7		V _{IN}	V
V _{il}	Low Level Input Voltage		0		0.7	V
V _{oh}	High Level Output Voltage (ALL_DONE Terminal)	I _{oh} = -4mA	2.0			V
V _{ol}	Low Level Output Voltage (ALL_DONE Terminal)	I _{ol} = 4mA			0.4	V
I _{ih}	Input High Current (PWDN Terminal)	V _{IN} = 3.6 V, LVC MOS = 3.6 V	-15		+15	µA
I _{il}	Input Low Current (PWDN Terminal)	V _{IN} = 3.6 V, LVC MOS = 0 V	-15		+15	µA
4-LEVEL INPUT DC SPECIFICATIONS						
I _{ih}	Input High Current with internal resistors (4-level input Terminal)	V _{IN} = 3.6 V, LVC MOS = 3.6 V	+20		+150	µA
I _{il}	Input Low Current with internal resistors (4-level input Terminal)	V _{IN} = 3.6 V, LVC MOS = 0 V	-160		-40	µA
V _{th}	Threshold 0 / R	V _{DD} = 2.5V (2.5V supply mode) Internal LDO Disabled See Table 1 for details		0.45		V
	Threshold R / Float			1.2		
	Threshold Float / 1			2		
	Threshold 0 / R	V _{IN} = 3.3V (3.3V supply mode) Internal LDO Enabled See Table 1 for details.		0.6		V
	Threshold R / Float			1.6		
	Threshold Float / 1			2.6		
CML RECEIVER INPUTS (IN_{n+}, IN_{n-})						
RL _{RX-diff}	RX Differential return loss	SDD11 10 MHz		-19		dB
		SDD11 2 GHz		-14		
		SDD11 6-11.1 GHz		-8		
RL _{RX-cm}	RX Common mode return loss	0.05 - 5 GHz		-10		dB
Z _{RX-dc}	RX DC common mode impedance	Tested at V _{DD} = 2.5 V	40	50	60	Ω
Z _{RX-diff-dc}	RX DC differential mode impedance	Tested at V _{DD} = 2.5 V	80	100	120	Ω
V _{RX-signal-det-diff-pp}	Signal detect assert level for active data signal	SD_TH = F (float), 0101 pattern at 12 Gbps		50		mVp-p
V _{RX-idle-det-diff-pp}	Signal detect de-assert level for electrical idle	SD_TH = F (float), 0101 pattern at 12 Gbps		37		mVp-p
HIGH SPEED OUTPUTS						
T _{TX-RISE-FALL}	Transmitter rise/fall time ⁽¹⁾	20% to 80% of differential output voltage		40		ps
T _{RF-MISMATCH}	Transmitter rise/fall mismatch	20% to 80% of differential output voltage		0.01		UI
RL _{TX-DIFF}	TX Differential return loss	SDD22 10 MHz - 2 GHz		-15		dB
		SDD22 5.5 GHz		-12		
		SDD22 11.1 GHz		-10		
RL _{TX-CM}	TX Common mode return loss	0.05 - 5 GHz		-10		dB
Z _{TX-DIFF-DC}	DC differential TX impedance			100		Ω
I _{TX-SHORT}	Transmitter short circuit current limit	Total current, output shorted to V _{DD} or GND		20		mA
V _{TX-CM-DC-ACTIVE-IDLE-DELTA}	Absolute delta of DC common mode voltage during L0 and electrical idle				100	mV

(1) Rise / Fall time measurements will on A-Channels will vary based on EQ setting, Input Amplitude, and input edge rate.

Electrical Characteristics (continued)

PARAMETER		TEST CONDITIONS	MIN	TYP	MAX	UNIT
$V_{TX-CM-DC-LINE-DELTA}$	Absolute delta of DC common mode voltage between TX+ and TX-				25	mV
HIGH SPEED OUTPUTS (A-CHANNELS)						
$V_{TXA-diff1-pp}$	Output Voltage Differential Swing	Differential measurement with OUTA_n+ and OUTA_n-, AC-Coupled and terminated by 50Ω to GND, Inputs AC-Coupled, VID = 600 mVp-p, VOD = 001'b (800mV)	375	465	600	mVp-p
$V_{TXA-diff2-pp}$	Output Voltage Differential Swing	Differential measurement with OUTA_n+ and OUTA_n-, AC-Coupled and terminated by 50Ω to GND, Inputs AC-Coupled, VID = 1000 mVp-p, VOD = 001'b (800mV)	550	675	825	mVp-p
$V_{TXA-diff3-pp}$	Output Voltage Differential Swing	Differential measurement with OUTA_n+ and OUTA_n-, AC-Coupled and terminated by 50Ω to GND, Inputs AC-Coupled, VID = 600 mVp-p, DEMA[1:0] = 10, VOD = 1300mV	475	600	750	Vp-p
$V_{TXA-diff4-pp}$	Output Voltage Differential Swing	Differential measurement with OUTA_n+ and OUTA_n-, AC-Coupled and terminated by 50Ω to GND, Inputs AC-Coupled, VID = 1000 mVp-p, VOD = 110'b (1300mV)	775	915	1125	Vp-p
$T_{TXA-IDLE-DATA}$	Time to transition to valid differential signal after idle	VID = 1.0 Vp-p, 3 Gbps		0.04		ns
$T_{TXA-DATA-IDLE}$	Time to transition to idle after differential signal	VID = 1.0 Vp-p, 3 Gbps		0.70		ns
T_{PDEQA}	Differential propagation delay - Channel A	EQ = Level 1 to Level 4		80		ps
HIGH SPEED OUTPUTS (B-CHANNELS)						
$V_{TXB-diff1-pp}$	Output Voltage Differential Swing	Differential measurement with OUTB_n+ and OUTB_n-, AC-Coupled and terminated by 50Ω to GND, Inputs AC-Coupled, VID = 1.0 Vp-p, MODE_B = 1, DEMB1 = 0, DEMB0 = 1 ⁽²⁾	0.8	1.0	1.2	Vp-p
$V_{TXB-diff2-pp}$	Output Voltage Differential Swing	Differential measurement with OUTB_n+ and OUTB_n-, AC-Coupled and terminated by 50Ω to GND, Inputs AC-Coupled, VID = 1.0 Vp-p, MODE_B = 0, DEMB1 = 0, DEMB0 = R	670	820	930	mVp-p
$V_{TXB-diff3-pp}$	Output Voltage Differential Swing	Differential measurement with OUTB_n+ and OUTB_n-, AC-Coupled and terminated by 50Ω to GND, Inputs AC-Coupled, VID = 1.0 Vp-p, MODE_B = 0, DEMB1 = R, DEMB0 = FLOAT	950	1140	1250	mVp-p

- (2) In SAS-3 and PCIe GEN3 mode, the output VOD level is not fixed. It will be adjusted automatically based on the VID input amplitude level. The output VOD level set by DEMA/B[1:0] in this mode BOUTn is dependent on the VID level and the frequency content. The DS125BR401A repeater is designed to be transparent in this mode, so the TX-FIR (de-emphasis) is passed to the RX to support the handshake negotiation link training.

Electrical Characteristics (continued)

PARAMETER	TEST CONDITIONS	MIN	TYP	MAX	UNIT
$V_{\text{TXB-de-ratio}_3.5}$	TX de-emphasis ratio		-3.5		dB
$V_{\text{TXB-de-ratio}_6}$	TX de-emphasis ratio		-6		dB
$T_{\text{TXB-IDLE-DATA}}$	Time to transition to valid differential signal after idle	VID = 1.0 Vp-p, 3 Gbps	3.5		ns
$T_{\text{TXB-DATA-IDLE}}$	Time to transition to idle after differential signal	VID = 1.0 Vp-p, 3 Gbps	5.0		ns
T_{PDEQB}	Differential propagation delay - Channel B	EQ = 00 ⁽³⁾	135		ps
EQUALIZATION (A-CHANNELS)					
DJE1A	Residual deterministic jitter at 6 Gbps	5" Differential Stripline, 5mil trace width, FR4, VID = 0.8 Vp-p, PRBS15, EQ = 01'h, VOD = 1.3V, DEM = 0 dB	0.06		UI
DJE3A	Residual deterministic jitter at 12 Gbps	5" Differential Stripline, 5mil trace width, FR4, VID = 0.8 Vp-p, PRBS15, EQ = 01'h, VOD = 1.3V, DEM = 0 dB	0.12		UI
EQUALIZATION (B-CHANNELS)					
DJE1B	Residual deterministic jitter at 12 Gbps	30" Differential Stripline, 5mil trace width, FR4, VID = 0.6 Vp-p, PRBS15, EQ = 07'h, DEM = 0 dB	0.18		UI
DJE2B	Residual deterministic jitter at 12 Gbps	5 meters 30 awg cable, VID = 0.6 Vp-p, PRBS15, EQ = 07'h, DEM = 0 dB	0.25		UI
DE-EMPHASIS (B-CHANNELS, GEN 1&2 MODE ONLY)					
DJD1	Residual deterministic jitter at 12 Gbps	Input Channel: 20" Differential Stripline, 5mil trace width, FR4, Output Channel: 10" Differential Stripline, 5mil trace width, FR4, VID = 0.6 Vp-p, PRBS15, EQ = 03'h, VOD = 1.0 Vp-p, DEMB = -3.5 dB	0.1		UI

(3) Propagation Delay measurements will change slightly based on the level of EQ selected. EQ = 00 will result in the shortest propagation delays.

6.6 Electrical Characteristics — Serial Management Bus Interface

Over recommended operating supply and temperature ranges unless other specified.

PARAMETER		TEST CONDITIONS	MIN	TYP	MAX	UNIT
SERIAL BUS INTERFACE DC SPECIFICATIONS						
V _{IL}	Data, Clock Input Low Voltage				0.8	V
V _{IH}	Data, Clock Input High Voltage		2.1		3.6	V
V _{OL}	Output Low Voltage	SDA or SCL, I _{OL} = 1.25 mA	0		0.36	V
V _{DD}	Nominal Bus Voltage		2.375		3.6	V
I _{IH-Terminal}	Input Leakage Per Device Terminal		+20		+150	μA
I _{IL-Terminal}	Input Leakage Per Device Terminal		-160		-40	μA
C _I	Capacitance for SDA and SCL	See ⁽¹⁾⁽²⁾		< 5		pF
R _{TERM}	External Termination Resistance pull to V _{DD} = 2.5V ± 5% OR 3.3V ± 10%	Pullup V _{DD} = 3.3V ⁽¹⁾⁽²⁾⁽³⁾ Pullup V _{DD} = 2.5V ⁽¹⁾⁽²⁾⁽³⁾		2000		Ω
				1000		Ω

- (1) Recommended value.
- (2) Recommended maximum capacitance load per bus segment is 400pF.
- (3) Maximum termination voltage should be identical to the device supply voltage.

6.7 Timing Requirements Serial Bus Interface

PARAMETER		TEST CONDITIONS	MIN	TYP	MAX	UNIT
SERIAL BUS INTERFACE TIMING SPECIFICATIONS						
FSMB	Bus Operating Frequency	ENSMB = VDD (Slave Mode)			400	kHz
		ENSMB = FLOAT (Master Mode)	280	400	520	kHz
t _{FALL}	SDA Fall Time	Read operation RPU = 4.7K, C _b < 50pF		60		ns
t _{RISE}	SDA Rise Time	Read operation RPU = 4.7K, C _b < 50pF		140		ns
t _F	Clock/Data Fall Time	See ⁽¹⁾			300	ns
t _R	Clock/Data Rise Time	See ⁽¹⁾			1000	ns

- (1) Compliant to SMBus 2.0 physical layer specification. See System Management Bus (SMBus) Specification Version 2.0, section 3.1.1 SMBus common AC specifications for details.

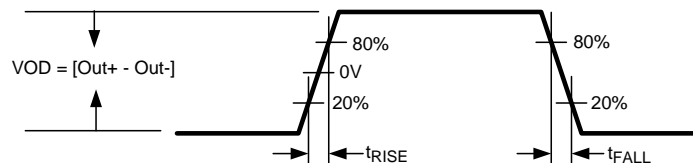

Figure 1. Output and Rise And Fall Transition Time

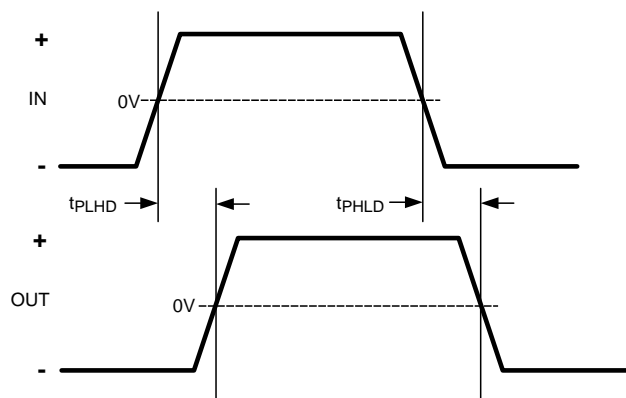

Figure 2. Propagation Delay Timing Diagram

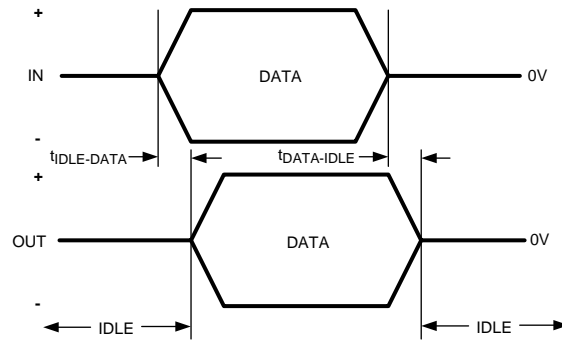

Figure 3. Transmit Idle-Data and Data-Idle Response Time

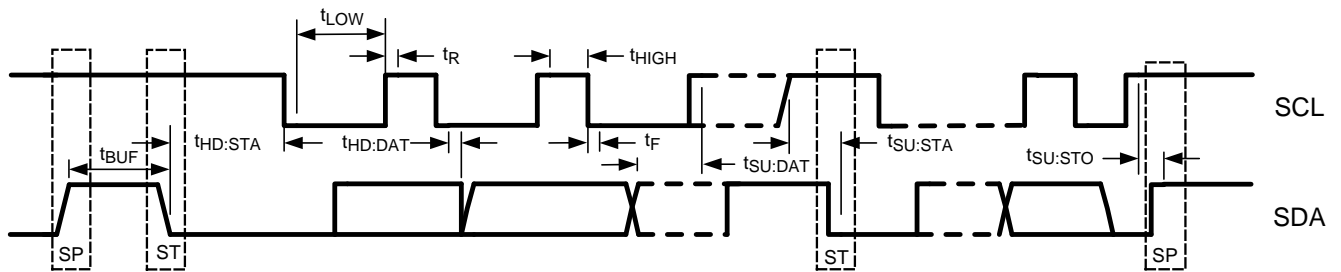

Figure 4. SMBus Timing Parameters

6.8 Typical Characteristics

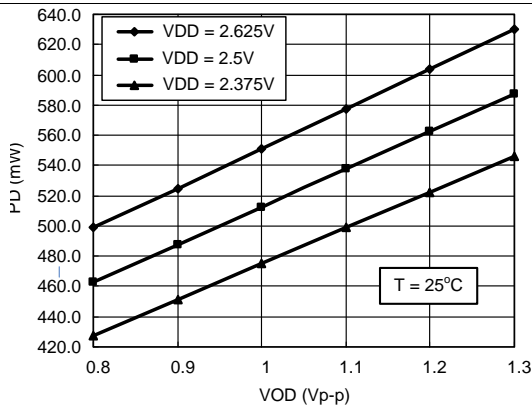

Figure 5. Typical Power Dissipation vs. Output Voltage Amplitude Setting

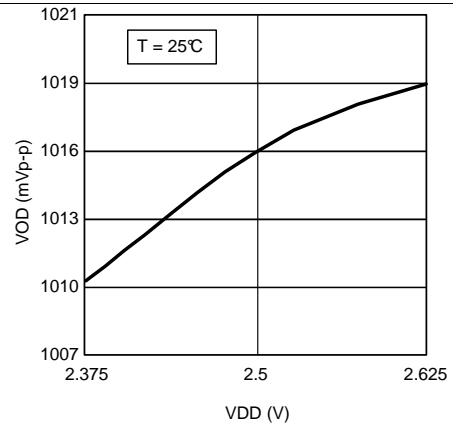

Figure 6. Channel-B Output Differential Voltage vs. VDD (VOD = 1000 mV setting)

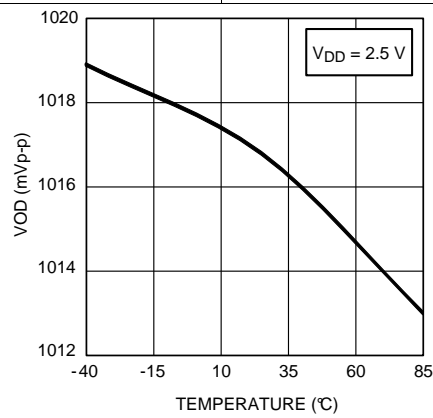

Figure 7. Channel-B Output Differential Voltage Vs. Temperature (VOD = 1000 mV setting)

7 Detailed Description

7.1 Overview

The DS125BR401A compensates for lossy FR-4 printed circuit board backplanes and balanced cables. The DS125BR401A operates in 3 modes: Terminal Control Mode (ENSMB = 0), SMBus Slave Mode (ENSMB = 1) and SMBus Master Mode (ENSMB = float) to load register information from external EEPROM; please refer to SMBus Master Mode for additional information.

7.2 Functional Block Diagram

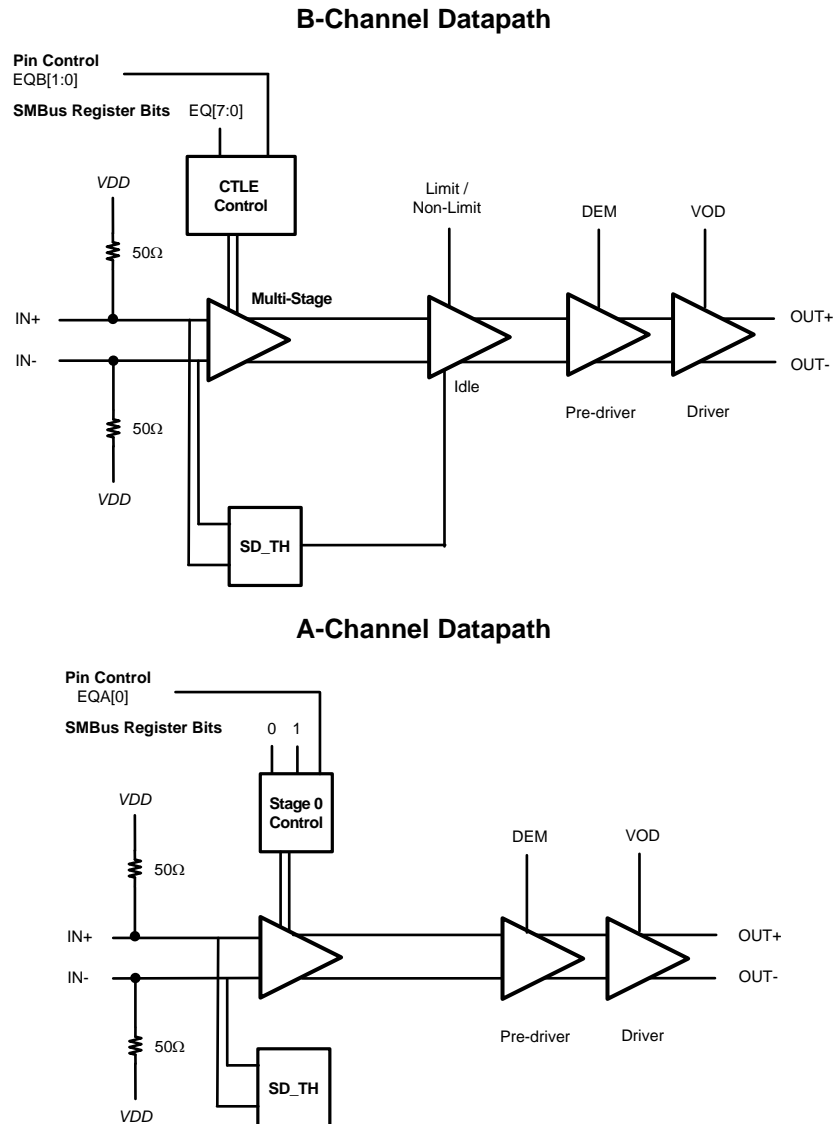

7.2.1 Functional Datapath Blocks

The Channel-B datapath is designed to handle higher levels of input attenuation and includes an output with a soft-limiting function to provide some transparency for Rx-Tx training in SAS-3 and other standards. The Channel-A datapath has less input equalization coupled with a linear driver. This combination has a high level of transparency, achieving greater drive distance in SAS-3 applications which utilize Rx-Tx training. The asymmetrical channel design follows the application diagram in .

Functional Block Diagram (continued)

The Channel-A and Channel-B data-paths are optimized to work as a transparent driver and a transparent receiver. The typical DS125BR401A system placement breaks a long transmission line into two pieces. This often leads to one short and one long piece, this unequal partition places different demands on A and B-Channels. To maximize channel extension with the DS125BR401A, connect the A-Channel Inputs to the channel segment with the lowest attenuation to the SAS-3 Tx.

7.3 Feature Description

The 4-level input Terminals utilize a resistor divider to help set the 4 valid levels and provide a wider range of control settings when ENSMB=0. There is an internal 30K pull-up and a 60K pull-down connected to the package Terminal. These resistors, together with the external resistor connection combine to achieve the desired voltage level. Using the 1K pull-up, 1K pull-down, no connect, and 20K pull-down provide the optimal voltage levels for each of the four input states.

Table 1. 4-Level Control Terminal Settings

Level	Setting	3.3V Mode	2.5V Mode
0	Tie 1kΩ to GND	0.10 V	0.08 V
R	Tie 20kΩ to GND	$1/3 \times V_{IN}$	$1/3 \times V_{DD}$
Float	Float (leave Terminal open)	$2/3 \times V_{IN}$	$2/3 \times V_{DD}$
1	Tie 1kΩ to V_{IN} or V_{DD}	$V_{IN} - 0.05 \text{ V}$	$V_{DD} - 0.04 \text{ V}$

Typical 4-Level Input Thresholds

- Level 1 - 2 = $0.2 \times V_{IN}$ or V_{DD}
- Level 2 - 3 = $0.5 \times V_{IN}$ or V_{DD}
- Level 3 - 4 = $0.8 \times V_{IN}$ or V_{DD}

In order to minimize the startup current associated with the integrated 2.5V regulator the 1K pull-up / pull-down resistors are recommended. If several 4 level inputs require the same setting, it is possible to combine two or more 1K resistors into a single lower value resistor. As an example; combining two inputs with a single 500 Ohm resistor is a good way to save board space.

7.4 Device Functional Modes

7.4.1 Terminal Control Mode:

When in Terminal mode (ENSMB = 0), equalization and de-emphasis can be selected via Terminal for each side independently. When de-emphasis is asserted VOD is automatically adjusted per [Table 7](#). For PCIe applications, the RXDET Terminals provides automatic and manual control for input termination (50Ω or >50KΩ). MODE_B setting is also Terminal controllable with Terminal selections (Gen 1/2, auto detect, and SAS-3 / PCIe Gen 3). The receiver electrical signal detect threshold is also adjustable via the SD_TH Terminal. For A-Side Channels this can only be used for status information, on B-Side Channels this threshold will determine when the output state, Mute if no signal is present or active with a valid input signal detected .

7.4.2 SMBus Mode:

When in SMBus mode (ENSMB = 1), the VOD (output amplitude), equalization, de-emphasis, and termination disable features are all programmable on a individual lane basis, instead of grouped by A or B as in the Terminal mode case. Upon assertion of ENSMB, the EQx and DEMx functions revert to register control immediately. The EQx and DEMx Terminals are converted to AD0-AD3 SMBus address inputs. The other external control Terminals (MODE_B, RXDET and SD_TH) remain active unless their respective registers are written to and the appropriate override bit is set, in which case they are ignored until ENSMB is driven low (Terminal mode). On power-up or when ENSMB is driven low all registers are reset to their default state. If PWDN is asserted while ENSMB is high, the registers retain their current state.

Device Functional Modes (continued)

Equalization settings accessible via the Terminal controls were chosen to meet the needs of most high speed applications. If additional fine tuning or adjustment is needed, additional equalization settings can be accessed via the SMBus registers. Each input has a total of 256 possible equalization settings. The tables show the 16 settings when the device is in Terminal mode. When using SMBus mode, the equalization, VOD and de-Emphasis levels are set by registers.

The 4-level input Terminals utilize a resistor divider to help set the 4 valid levels and provide a wider range of control settings when ENSMB=0. There is an internal 30K pull-up and a 60K pull-down connected to the package Terminal. These resistors, together with the external resistor connection combine to achieve the desired voltage level. Using the 1K pull-up, 1K pull-down, no connect, and 20K pull-down provide the optimal voltage levels for each of the four input states.

Table 2. RX-Detect Settings

PWDN (Terminal 52)	RXDET (Terminal 22)	SMBus REG Bit[3:2]	INPUT TERMINATION	RECOMMENDED USE	COMMENTS
0	0	00	Hi-Z	X	Manual RX-Detect, input is high impedance mode
0	Tie 20kΩ to GND	01	Pre Detect: Hi-Z Post Detect: 50 Ω	PCIe only	Auto RX-Detect, outputs test every 12 msec for 600 msec then stops; termination is Hi-Z until RX detection; once detected input termination is 50 Ω Reset function by pulsing PWDN high for 5 usec then low again
0	Float (Default)	10	Pre Detect: Hi-Z Post Detect: 50 Ω	PCIe only	Auto RX-Detect, outputs test every 12 msec until detection occurs; termination is Hi-Z until RX detection; once detected input termination is 50 Ω
0	1	11	50 Ω	All Others	Manual RX-Detect, input is 50 Ω
1	X		High Impedance	X	Power down mode, input is Hi-Z, output drivers are disabled Used to reset RX-Detect State Machine when held high for 5 usec

Table 3. OOB And Signal Detect Threshold Level⁽¹⁾

SD_TH (Terminal 26)	SMBus REG BIT [3:2] and [1:0]	[3:2] ASSERT LEVEL (mVp-p)		[1:0] DE-ASSERT LEVEL (mVp-p)	
		3 Gbps	12 Gbps	3 Gbps	12 Gbps
0	10	18	75	14	55
R	01	12	40	8	22
F (default)	00	15	50	11	37
1	11	16	58	12	45

(1) VDD = 2.5V, 25°C, 11 00 11 00 pattern at 3 Gbps and 101010 pattern at 12 Gbps

Table 4. Mode Operation With Terminal Control

MODE_B (Terminal 21)	Driver characteristics	PCIe	SAS SATA	10GbE	CPRI OBSAI	SRIO (R)XAUI	Interlaken Infiniband
0	Limiting		X (≤ 6G)	X	X	X	X
R	Transparent without DE						
F (default)	Automatic	X					
1	Transparent with DE		X (SAS-3)				

7.4.3 MODE operation with SMBus Registers

When in SMBus mode (Slave or Master), the MODE Terminal retains control of the output driver characteristics. In order to override this control function, Register 0x08[2] must be written with a "1". Writing this bit enables MODE control of each channel individually using the channel registers defined in Table 9. For Channel-A outputs the MODE control bit is not functional. The outputs are always in a linear mode of operation. Changing these bits while Register 0x08[2]=1 will dramatically reduce the output amplitude.

7.5 Signal Conditioning Settings

Information in [Table 5](#) and [Table 6](#) shows the level of CTLE or equalization gain for Channel-B and Channel-A.

Table 5. B-Channel Equalizer Settings

Level	EQB1	EQB0	EQ – 8 bits [7:0]	dB at 1.5 GHz	dB at 2.5 GHz	dB at 4 GHz	dB at 6 GHz	Suggested Use ⁽¹⁾
1	0	0	0000 0000 = 0x00	2.5	3.5	3.8	3.1	FR4 < 5 inch trace
2	0	R	0000 0001 = 0x01	3.8	5.4	6.7	6.7	FR4 5-10 inch trace
3	0	Float	0000 0010 = 0x02	5.0	7.0	8.4	8.4	FR4 10 inch trace
4	0	1	0000 0011 = 0x03	5.9	8.0	9.3	9.1	FR4 15-20 inch trace
5	R	0	0000 0111 = 0x07	7.4	10.3	12.8	13.7	FR4 20-30 inch trace
6	R	R	0001 0101 = 0x15	6.9	10.2	13.9	16.2	FR4 25-30 inch trace
7	R	Float	0000 1011 = 0x0B	9.0	12.4	15.3	15.9	FR4 25-30 inch trace
8	R	1	0000 1111 = 0x0F	10.2	13.8	16.7	17.0	8m, 30awg cable
9	Float	0	0101 0101 = 0x55	8.5	12.6	17.5	20.7	> 8m cable
10	Float	R	0001 1111 = 0x1F	11.7	16.2	20.3	21.8	
11	Float	Float	0010 1111 = 0x2F	13.2	18.3	22.8	23.6	
12	Float	1	0011 1111 = 0x3F	14.4	19.8	24.2	24.7	
13	1	0	1010 1010 = 0xAA	14.4	20.5	26.4	28.0	
14	1	R	0111 1111 = 0x7F	16.0	22.2	27.8	29.2	
15	1	Float	1011 1111 = 0xBF	17.6	24.4	30.2	30.9	
16	1	1	1111 1111 = 0xFF	18.7	25.8	31.6	31.9	

(1) Cable and FR4 lengths are for reference only. FR4 lengths based on a 100 Ohm differential stripline with 5-mil traces and 8-mil trace separation. Optimal EQ setting should be determined via simulation and prototype verification.

Table 6. A-Channel Equalizer Settings

Level	EQA1	EQA0	EQ – 8 bits [7:0]	dB at 1.5 GHz	dB at 2.5 GHz	dB at 4 GHz	dB at 6 GHz	Suggested Use ⁽¹⁾
1	N/A	0	xxxx xx00 = 0x00	2.5	3.5	3.8	3.1	
2	N/A	R	xxxx xx01 = 0x01	3.8	5.4	6.7	6.7	
3	N/A	Float	xxxx xx10 = 0x02	5.0	7.0	8.4	8.4	
4	N/A	1	xxxx xx11 = 0x03	5.9	8.0	9.3	9.1	SAS-3

(1) Cable and FR4 lengths are for reference only. FR4 lengths based on a 100 Ohm differential stripline with 5-mil traces and 8-mil trace separation. Optimal EQ setting should be determined via simulation and prototype verification.

Table 7. B-Channel Output Voltage And De-Emphasis Settings

Level	DEMB1	DEMB0	VOD Vp-p	DEM dB ⁽¹⁾	Inner Amplitude Vp-p	Suggested Use ⁽²⁾
1	0	0	0.8	0	0.8	FR4 <5 inch trace
2	0	R	0.9	0	0.9	FR4 <5 inch trace
3	0	Float	0.9	- 3.5	0.6	FR4 10 inch trace
4	0	1	1.0	0	1.0	FR4 <5 inch trace
5	R	0	1.0	- 3.5	0.7	FR4 10 inch trace
6	R	R	1.0	- 6	0.5	FR4 15 inch trace
7	R	Float	1.1	0	1.1	FR4 <5 inch trace
8	R	1	1.1	- 3.5	0.7	FR4 10 inch trace
9	Float	0	1.1	- 6	0.6	FR4 15 inch trace
10	Float	R	1.2	0	1.2	FR4 <5 inch trace
11	Float	Float	1.2	- 3.5	0.8	FR4 10 inch trace
12	Float	1	1.2	- 6	0.6	FR4 15 inch trace
13	1	0	1.3	0	1.3	FR4 <5 inch trace
14	1	R	1.3	- 3.5	0.9	FR4 10 inch trace
15	1	Float	1.3	- 6	0.7	FR4 15 inch trace
16	1	1	1.3	- 9	0.5	FR4 20 inch trace

(1) The VOD output amplitude and DEM de-emphasis levels are set with the DEMB[1:0] Terminals.

(2) FR4 lengths are for reference only. FR4 lengths based on a 100 Ohm differential stripline with 5-mil traces and 8-mil trace separation. Optimal DEM settings should be determined via simulation and prototype verification.

Table 8. A-Channel Output Voltage And De-Emphasis Settings

Level	DEMA1	DEMA0	VID Vp-p	DEM Setting ⁽¹⁾	VOD Vp-p
1	0	0	1.0	0	0.70
2	0	R	1.0	0	0.78
4	0	1	1.0	0	0.83
7	R	Float	1.0	0	0.88
10	Float	R	1.0	0	0.91
13	1	0	1.0	0	1.00

(1) The VOD output amplitude is set with the DEMA[1:0] Terminals. For SAS-3 operation the DEM level is typically left at 0 dB (SMBus control = 000'b) in order to keep the output dynamic range as large as possible. DEM settings other than 0 dB or 000'b will decrease the output dynamic range and act to limit the OUTA VOD. When operating in Terminal Mode in a SAS3 environment it is recommended to use DEMA[1:0] = 10'b.

Table 9. EEPROM Register Map - Single Device With Default Value

EEPROM Address Byte		Bit 7	Bit 6	Bit 5	Bit 4	Bit 3	Bit 2	Bit 1	Bit 0
Description	0	CRC EN	Address Map Present	EEPROM > 256 Bytes	RES	DEVICE COUNT[3]	DEVICE COUNT[2]	DEVICE COUNT[1]	DEVICE COUNT[0]
Value		00	0	0	0	0	0	0	0
Description	1	RES	RES	RES	RES	RES	RES	RES	RES
Value		00	0	0	0	0	0	0	0
Description	2	Max EEPROM Burst size[7]	Max EEPROM Burst size[6]	Max EEPROM Burst size[5]	Max EEPROM Burst size[4]	Max EEPROM Burst size[3]	Max EEPROM Burst size[2]	Max EEPROM Burst size[1]	Max EEPROM Burst size[0]
Value		00	0	0	0	0	0	0	0
Description	3	PWDN_CH7	PWDN_CH6	PWDN_CH5	PWDN_CH4	PWDN_CH3	PWDN_CH2	PWDN_CH1	PWDN_CH0
SMBus Register		0x01 [7]	0x01 [6]	0x01 [5]	0x01 [4]	0x01 [3]	0x01 [2]	0x01 [1]	0x01 [0]
Value		00	0	0	0	0	0	0	0
Description	4	Reserved	Reserved	Reserved	Reserved	Ovrd_PWDN	CH7_EQ_LIM	CH6_EQ_LIM	CH5_EQ_LIM
SMBus Register		0x02 [5]	0x02 [4]	0x02 [3]	0x02 [2]	0x02 [0]	0x04 [7]	0x04 [6]	0x04 [5]
Value		00	0	0	0	0	0	0	0
Description	5	CH4_EQ_LIM	CH3_EQ_LIM	CH2_EQ_LIM	CH1_EQ_LIM	CH0_EQ_LIM	rxdet_btb_en	Ovrd_SD_TH	Reserved
SMBus Register		0x04 [4]	0x04 [3]	0x04 [2]	0x04 [1]	0x04 [0]	0x06 [4]	0x08 [6]	0x08 [5]
Value		04	0	0	0	0	1	0	0
Description	6	Ovrd_IDLE	Ovrd_RX_DET	Ovrd_MODE	Reserved	Reserved	rxdet_delay_2	rxdet_delay_1	rxdet_delay_0
SMBus Register		0x08 [4]	0x08 [3]	0x08 [2]	0x08 [1]	0x08 [0]	0x0B [6]	0x0B [5]	0x0B [4]
Value		07	0	0	0	0	1	1	1
Description	7	rate_delay_3	rate_delay_2	rate_delay_1	rate_delay_0	CH0_Idle_auto	CH0_Idle_sel	CH0_Rxdet_1	CH0_Rxdet_0
SMBus Register		0x0B [3]	0x0B [2]	0x0B [1]	0x0B [0]	0x0E [5]	0x0E [4]	0x0E [3]	0x0E [2]
Value		00	0	0	0	0	0	0	0
Description	8	CH0_EQ_7	CH0_EQ_6	CH0_EQ_5	CH0_EQ_4	CH0_EQ_3	CH0_EQ_2	CH0_EQ_1	CH0_EQ_0
SMBus Register		0x0F [7]	0x0F [6]	0x0F [5]	0x0F [4]	0x0F [3]	0x0F [2]	0x0F [1]	0x0F [0]
Value		2F	0	0	1	0	1	1	1
Description	9	CH0_SCP	CH0_MODE	Reserved	Reserved	Reserved	CH0_VOD_2	CH0_VOD_1	CH0_VOD_0
SMBus Register		0x10 [7]	0x10 [6]	0x10 [5]	0x10 [4]	0x10 [3]	0x10 [2]	0x10 [1]	0x10 [0]
Value		AD	1	0	1	0	1	1	0

Table 9. EEPROM Register Map - Single Device With Default Value (continued)

EEPROM Address Byte		Bit 7	Bit 6	Bit 5	Bit 4	Bit 3	Bit 2	Bit 1	Bit 0
Description	A	CH0_DEM_2	CH0_DEM_1	CH0_DEM_0	Reserved	CH0_THa_1	CH0_THa_0	CH0_THd_1	CH0_THd_0
SMBus Register		0x11 [2]	0x11 [1]	0x11 [0]	0x12 [7]	0x12 [3]	0x12 [2]	0x12 [1]	0x12 [0]
Value		40	0	1	0	0	0	0	0
Description	B	CH1_Idle_auto	CH1_Idle_sel	CH1_Rxdet_1	CH1_Rxdet_0	CH1_EQ_7	CH1_EQ_6	CH1_EQ_5	CH1_EQ_4
SMBus Register		0x15 [5]	0x15 [4]	0x15 [3]	0x15 [2]	0x16 [7]	0x16 [6]	0x16 [5]	0x16 [4]
Value		02	0	0	0	0	0	1	0
Description	C	CH1_EQ_3	CH1_EQ_2	CH1_EQ_1	CH1_EQ_0	CH1_SCP	CH1_MODE	Reserved	Reserved
SMBus Register		0x16 [3]	0x16 [2]	0x16 [1]	0x16 [0]	0x17 [7]	0x17 [6]	0x17 [5]	0x17 [4]
Value		FA	1	1	1	1	1	0	1
Description	D	Reserved	CH1_VOD_2	CH1_VOD_1	CH1_VOD_0	CH1_DEM_2	CH1_DEM_1	CH1_DEM_0	Reserved
SMBus Register		0x17 [3]	0x17 [2]	0x17 [1]	0x17 [0]	0x18 [2]	0x18 [1]	0x18 [0]	0x19 [7]
Value		D4	1	1	0	1	0	1	0
Description	E	CH1_THa_1	CH1_THa_0	CH1_THd_1	CH1_THd_0	CH2_Idle_auto	CH2_Idle_sel	CH2_Rxdet_1	CH2_Rxdet_0
SMBus Register		0x19 [3]	0x19 [2]	0x19 [1]	0x19 [0]	0x1C [5]	0x1C [4]	0x1C [3]	0x1C [2]
Value		00	0	0	0	0	0	0	0
Description	F	CH2_EQ_7	CH2_EQ_6	CH2_EQ_5	CH2_EQ_4	CH2_EQ_3	CH2_EQ_2	CH2_EQ_1	CH2_EQ_0
SMBus Register		0x1D [7]	0x1D [6]	0x1D [5]	0x1D [4]	0x1D [3]	0x1D [2]	0x1D [1]	0x1D [0]
Value		2F	0	0	1	0	1	1	1
Description	10	CH2_SCP	CH2_MODE	Reserved	Reserved	Reserved	CH2_VOD_2	CH2_VOD_1	CH2_VOD_0
SMBus Register		0x1E [7]	0x1E [6]	0x1E [5]	0x1E [4]	0x1E [3]	0x1E [2]	0x1E [1]	0x1E [0]
Value		AD	1	0	1	0	1	1	0
Description	11	CH2_DEM_2	CH2_DEM_1	CH2_DEM_0	Reserved	CH2_THa_1	CH2_THa_0	CH2_THd_1	CH2_THd_0
SMBus Register		0x1F [2]	0x1F [1]	0x1F [0]	0x20 [7]	0x20 [3]	0x20 [2]	0x20 [1]	0x20 [0]
Value		40	0	1	0	0	0	0	0
Description	12	CH3_Idle_auto	CH3_Idle_sel	CH3_Rxdet_1	CH3_Rxdet_0	CH3_EQ_7	CH3_EQ_6	CH3_EQ_5	CH3_EQ_4
SMBus Register		0x23 [5]	0x23 [4]	0x23 [3]	0x23 [2]	0x24 [7]	0x24 [6]	0x24 [5]	0x24 [4]
Value		02	0	0	0	0	0	1	0
Description	13	CH3_EQ_3	CH3_EQ_2	CH3_EQ_1	CH3_EQ_0	CH3_SCP	CH3_MODE	Reserved	Reserved
SMBus Register		0x24 [3]	0x24 [2]	0x24 [1]	0x24 [0]	0x25 [7]	0x25 [6]	0x25 [5]	0x25 [4]
Value		FA	1	1	1	1	1	0	1

Table 9. EEPROM Register Map - Single Device With Default Value (continued)

EEPROM Address Byte		Bit 7	Bit 6	Bit 5	Bit 4	Bit 3	Bit 2	Bit 1	Bit 0
Description	14	Reserved	CH3_VOD_2	CH3_VOD_1	CH3_VOD_0	CH3_DEM_2	CH3_DEM_1	CH3_DEM_0	Reserved
SMBus Register		0x25 [3]	0x25 [2]	0x25 [1]	0x25 [0]	0x26 [2]	0x26 [1]	0x26 [0]	0x27 [7]
Value		D4	1	1	0	1	0	1	0
Description	15	CH3_THa_1	CH3_THa_0	CH3_THd_1	CH3_THd_0	ovrd_fast_idle	hi_idle_th CH0-3	hi_idle_thCH4-7	fast_idle CH0-3
SMBus Register		0x27 [3]	0x27 [2]	0x27 [1]	0x27 [0]	0x28 [6]	0x28 [5]	0x28 [4]	0x28 [3]
Value		09	0	0	0	1	0	0	1
Description	16	fast_idle CH4-7	low_gain CH0-3	low_gain CH4-7	CH4_Idle_auto	CH4_Idle_sel	CH4_Rxdet_1	CH4_Rxdet_0	Reserved
SMBus Register		0x28 [2]	0x28 [1]	0x28 [0]	0x2B [5]	0x2B [4]	0x2B [3]	0x2B [2]	0x2C [7]
Value		80	1	0	0	0	0	0	0
Description	17	Reserved	Reserved	Reserved	Reserved	Reserved	CH4_EQ_1	CH4_EQ_0	CH4_SCP
SMBus Register		0x2C [6]	0x2C [5]	0x2C [4]	0x2C [3]	0x2C [2]	0x2C [1]	0x2C [0]	0x2D [7]
Value		5F	0	1	0	1	1	1	1
Description	18	Reserved	Reserved	Reserved	Reserved	CH4_VOD_2	CH4_VOD_1	CH4_VOD_0	CH4_DEM_2
SMBus Register		0x2D [6]	0x2D [5]	0x2D [4]	0x2D [3]	0x2D [2]	0x2D [1]	0x2D [0]	0x2E [2]
Value		5A	0	1	0	1	1	0	1
Description	19	CH4_DEM_1	CH4_DEM_0	Reserved	CH4_THa_1	CH4_THa_0	CH4_THd_1	CH4_THd_0	CH5_Idle_auto
SMBus Register		0x2E [1]	0x2E [0]	0x2F [7]	0x2F [3]	0x2F [2]	0x2F [1]	0x2F [0]	0x32 [5]
Value		80	1	0	0	0	0	0	0
Description	1A	CH5_Idle_sel	CH5_Rxdet_1	CH5_Rxdet_0	Reserved	Reserved	Reserved	Reserved	Reserved
SMBus Register		0x32 [4]	0x32 [3]	0x32 [2]	0x33 [7]	0x33 [6]	0x33 [5]	0x33 [4]	0x33 [3]
Value		05	0	0	0	0	1	0	1
Description	1B	Reserved	CH5_EQ_1	CH5_EQ_0	CH5_SCP	Reserved	Reserved	Reserved	Reserved
SMBus Register		0x33 [2]	0x33 [1]	0x33 [0]	0x34 [7]	0x34 [6]	0x34 [5]	0x34 [4]	0x34 [3]
Value		F5	1	1	1	1	0	1	0
Description	1C	CH5_VOD_2	CH5_VOD_1	CH5_VOD_0	CH5_DEM_2	CH5_DEM_1	CH5_DEM_0	Reserved	CH5_THa_1
SMBus Register		0x34 [2]	0x34 [1]	0x34 [0]	0x35 [2]	0x35 [1]	0x35 [0]	0x36 [7]	0x36 [3]
Value		A8	1	0	1	0	1	0	0
Description	1D	CH5_THa_0	CH5_THd_1	CH5_THd_0	CH6_Idle_auto	CH6_Idle_sel	CH6_Rxdet_1	CH6_Rxdet_0	Reserved
SMBus Register		0x36 [2]	0x36 [1]	0x36 [0]	0x39 [5]	0x39 [4]	0x39 [3]	0x39 [2]	0x3A [7]
Value		00	0	0	0	0	0	0	0

Table 9. EEPROM Register Map - Single Device With Default Value (continued)

EEPROM Address Byte		Bit 7	Bit 6	Bit 5	Bit 4	Bit 3	Bit 2	Bit 1	Bit 0
Description	1E	Reserved	Reserved	Reserved	Reserved	Reserved	CH6_EQ_1	CH6_EQ_0	CH6_SCP
SMBus Register		0x3A [6]	0x3A [5]	0x3A [4]	0x3A [3]	0x3A [2]	0x3A [1]	0x3A [0]	0x3B [7]
Value		5F	0	1	0	1	1	1	1
Description	1F	Reserved	Reserved	Reserved	Reserved	CH6_VOD_2	CH6_VOD_1	CH6_VOD_0	CH6_DEM_2
SMBus Register		0x3B [6]	0x3B [5]	0x3B [4]	0x3B [3]	0x3B [2]	0x3B [1]	0x3B [0]	0x3C [2]
Value		5A	0	1	0	1	1	0	1
Description	20	CH6_DEM_1	CH6_DEM_0	Reserved	CH6_THa_1	CH6_THa_0	CH6_THd_1	CH6_THd_0	CH7_Idle_auto
SMBus Register		0x3C [1]	0x3C [0]	0x3D [7]	0x3D [3]	0x3D [2]	0x3D [1]	0x3D [0]	0x40 [5]
Value		80	1	0	0	0	0	0	0
Description	21	CH7_Idle_sel	CH7_Rxdet_1	CH7_Rxdet_0	Reserved	Reserved	Reserved	Reserved	Reserved
SMBus Register		0x40 [4]	0x40 [3]	0x40 [2]	0x41 [7]	0x41 [6]	0x41 [5]	0x41 [4]	0x41 [3]
Value		05	0	0	0	0	0	1	0
Description	22	Reserved	CH7_EQ_1	CH7_EQ_0	CH7_SCP	Reserved	Reserved	Reserved	Reserved
SMBus Register		0x41 [2]	0x41 [1]	0x41 [0]	0x42 [7]	0x42 [6]	0x42 [5]	0x42 [4]	0x42 [3]
Value		F5	1	1	1	1	0	1	0
Description	23	CH7_VOD_2	CH7_VOD_1	CH7_VOD_0	CH7_DEM_2	CH7_DEM_1	CH7_DEM_0	Reserved	CH7_THa_1
SMBus Register		0x42 [2]	0x42 [1]	0x42 [0]	0x43 [2]	0x43 [1]	0x43 [0]	0x44 [7]	0x44 [3]
Value		A8	1	0	1	0	1	0	0
Description	24	CH7_THa_0	CH7_THd_1	CH7_THd_0	Reserved	Reserved	Reserved	Reserved	Reserved
SMBus Register		0x44 [2]	0x44 [1]	0x44 [0]	0x47 [3]	0x47 [2]	0x47 [2]	0x47 [0]	0x48 [7]
Value		00	0	0	0	0	0	0	0
Description	25	Reserved	Reserved	Reserved	Reserved	Reserved	Reserved	Reserved	Reserved
SMBus Register		0x48 [6]	0x4C [7]	0x4C [6]	0x4C [5]	0x4C [4]	0x4C [3]	0x4C [0]	0x59 [0]
Value		00	0	0	0	0	0	0	0
Description	26	Reserved	Reserved	Reserved	Reserved	Reserved	Reserved	Reserved	Reserved
SMBus Register		0x5A [7]	0x5A [6]	0x5A [5]	0x5A [4]	0x5A [3]	0x5A [2]	0x5A [1]	0x5A [0]
Value		54	0	1	0	1	0	1	0
Description	27	Reserved	Reserved	Reserved	Reserved	Reserved	Reserved	Reserved	Reserved
SMBus Register		0x5B [7]	0x5B [6]	0x5B [5]	0x5B [4]	0x5B [3]	0x5B [2]	0x5B [1]	0x5B [0]
Value		54	0	1	0	1	0	1	0

Table 10. Example Of EEPROM For Four Devices Using Two Address Maps

EEPROM Address	Address (Hex)	EEPROM Data	Comments
0	00	0x43	CRC_EN = 0, Address Map = 1, >256 bytes = 0, Device Count[3:0] = 3
1	01	0x00	
2	02	0x08	EEPROM Burst Size
3	03	0x00	CRC not used
4	04	0x0B	Device 0 Address Location
5	05	0x00	CRC not used
6	06	0x0B	Device 1 Address Location
7	07	0x00	CRC not used
8	08	0x30	Device 2 Address Location
9	09	0x00	CRC not used
10	0A	0x30	Device 3 Address Location
11	0B	0x00	Begin Device 0, 1 - Address Offset 3
12	0C	0x00	
13	0D	0x04	
14	0E	0x07	
15	0F	0x00	
16	10	0x01	EQ CHB0 = 01
17	11	0xAD	VOD CHB0 = 1.2V
18	12	0x00	DEM CHB0 = 0 (0dB)
19	13	0x00	EQ CHB1 = 01
20	14	0x1A	VOD CHB1 = 1.2V
21	15	0xD0	DEM CHB1 = 0 (0dB)
22	16	0x00	
23	17	0x01	EQ CHB2 = 01
24	18	0xAD	VOD CHB2 = 1.2V
25	19	0x00	DEM CHB2 = 0 (0dB)
26	1A	0x00	EQ CHB3 = 01
27	1B	0x1A	VOD CHB3 = 1.2V
28	1C	0xD0	DEM CHB3 = 0 (0dB)
29	1D	0x09	Signal Detect Control
30	1E	0x80	Signal Detect Control
31	1F	0x07	EQ CHA0 = 03
32	20	0x5E	VOD CHA0 = 111'b
33	21	0x00	DEM CHA0 = 0 (0dB)
34	22	0x00	EQ CHA1 = 03
35	23	0x75	VOD CHA1 = 111'b
36	24	0xE0	DEM CHA1 = 0 (0dB)
37	25	0x00	
38	26	0x07	EQ CHA2 = 03
39	27	0x5E	VOD CHA2 = 1.4V
40	28	0x00	DEM CHA2 = 0 (0dB)
41	29	0x00	EQ CHA3 = 03
42	2A	0x75	VOD CHA3 = 111'b
43	2B	0xE0	DEM CHA3 = 0 (0dB)
44	2C	0x00	
45	2D	0x00	
46	2E	0x54	

Table 10. Example Of EEPROM For Four Devices Using Two Address Maps (continued)

EEPROM Address	Address (Hex)	EEPROM Data	Comments
47	2F	0x54	End Device 0, 1 - Address Offset 39
48	30	0x00	Begin Device 2, 3 - Address Offset 3
49	31	0x00	
50	32	0x04	
51	33	0x07	
52	34	0x00	
53	35	0x01	EQ CHB0 = 01
54	36	0xAB	VOD CHB0 = 1.0V
55	37	0x00	DEM CHB0 = 0 (0dB)
56	38	0x00	EQ CHB1 = 01
57	39	0x1A	VOD CHB1 = 1.0V
58	3A	0xB0	DEM CHB1 = 0 (0dB)
59	3B	0x00	
60	3C	0x01	EQ CHB2 = 01
61	3D	0xAB	VOD CHB2 = 1.0V
62	3E	0x00	DEM CHB2 = 0 (0dB)
63	3F	0x00	EQ CHB3 = 01
64	40	0x1A	VOD CHB3 = 1.0V
65	41	0xB0	DEM CHB3 = 0 (0dB)
66	42	0x09	Signal Detect Control
67	43	0x80	Signal Detect Control
68	44	0x03	EQ CHA0 = 01
69	45	0x5E	VOD CHA0 = 111'b
70	46	0x00	DEM CHA0 = 0 (0dB)
71	47	0x00	EQ CHA1 = 01
72	48	0x35	VOD CHA1 = 111'b
73	49	0xE0	DEM CHA1 = 0 (0dB)
74	4A	0x00	
75	4B	0x03	EQ CHA2 = 01
76	4C	0x5E	VOD CHA2 = 111'b
77	4D	0x00	DEM CHA2 = 0 (0dB)
78	4E	0x00	EQ CHA3 = 01
79	4F	0x35	VOD CHA3 = 111'b
80	50	0xE0	DEM CHA3 = 0 (0dB)
81	51	0x00	
82	52	0x00	
83	53	0x54	
84	54	0x54	End Device 2, 3 - Address Offset 39

Note: CRC_EN = 0, Address Map = 1, >256 byte = 0, Device Count[3:0] = 3. Multiple devices can point to the same address map. Maximum EEPROM size is 8 kbits (1024 x 8-bits).

7.7 Register Maps

The System Management Bus interface is compatible to SMBus 2.0 physical layer specification. ENSMB = 1k Ω to VDD to enable SMBus slave mode and allow access to the configuration registers.

The DS125BR401A has the AD[3:0] inputs in SMBus mode. These Terminals are the user set SMBus slave address inputs. The AD[3:0] Terminals have internal pull-down. When left floating or pulled low the AD[3:0] = 0000'b, the device default address byte is B0'h. Based on the SMBus 2.0 specification, the DS125BR401A has a 7-bit slave address. The LSB is set to 0'b (for a WRITE). The device supports up to 16 address byte, which can be set with the AD[3:0] inputs. Below are the 16 addresses.

Table 11. Device Slave Address Bytes

AD[3:0] Settings	Address Bytes (HEX)
0000	B0
0001	B2
0010	B4
0011	B6
0100	B8
0101	BA
0110	BC
0111	BE
1000	C0
1001	C2
1010	C4
1011	C6
1100	C8
1101	CA
1110	CC
1111	CE

The SDA, SCL Terminals are 3.3V tolerant, but are not 5V tolerant. External pull-up resistor is required on the SDA. The resistor value can be from 1 k Ω to 5 k Ω depending on the voltage, loading and speed. The SCL may also require an external pull-up resistor and it depends on the Host that drives the bus.

7.7.1 Transfer Of Data Via The SMBus

During normal operation the data on SDA must be stable during the time when SCL is High.

There are three unique states for the SMBus:

START: A High-to-Low transition on SDA while SCL is High indicates a message START condition.

STOP: A Low-to-High transition on SDA while SCL is High indicates a message STOP condition.

IDLE: If SCL and SDA are both High for a time exceeding t_{BUF} from the last detected STOP condition or if they are High for a total exceeding the maximum specification for t_{HIGH} then the bus will transfer to the IDLE state.

7.7.2 SMBus Transactions

The device supports WRITE and READ transactions. See [Table 12](#) for register address, type (Read/Write, Read Only), default value and function information.

7.7.3 Writing a Register

To write a register, the following protocol is used (see SMBus 2.0 specification).

1. The Host drives a START condition, the 7-bit SMBus address, and a “0” indicating a WRITE.
2. The Device (Slave) drives the ACK bit (“0”).
3. The Host drives the 8-bit Register Address.
4. The Device drives an ACK bit (“0”).
5. The Host drive the 8-bit data byte.
6. The Device drives an ACK bit (“0”).
7. The Host drives a STOP condition.

The WRITE transaction is completed, the bus goes IDLE and communication with other SMBus devices may now occur.

7.7.4 Reading a Register

To read a register, the following protocol is used (see SMBus 2.0 specification).

1. The Host drives a START condition, the 7-bit SMBus address, and a “0” indicating a WRITE.
2. The Device (Slave) drives the ACK bit (“0”).
3. The Host drives the 8-bit Register Address.
4. The Device drives an ACK bit (“0”).
5. The Host drives a START condition.
6. The Host drives the 7-bit SMBus Address, and a “1” indicating a READ.
7. The Device drives an ACK bit “0”.
8. The Device drives the 8-bit data value (register contents).
9. The Host drives a NACK bit “1” indicating end of the READ transfer.
10. The Host drives a STOP condition.

The READ transaction is completed, the bus goes IDLE and communication with other SMBus devices may now occur.

[Table 12](#) for more information.

Table 12. SMBus Slave Mode Register Map

Address	Register Name	Bit	Field	Type	Default	Description
0x00	Observation	7	Reserved	R/W	0x00	Set bit to 0.
		6:3	Address Bit AD[3:0]	R		Observation of AD[3:0] bits [6]: AD3 [5]: AD2 [4]: AD1 [3]: AD0
		2	EEPROM Read Done	R		1: Device completed the read from external EEPROM.
		1	Reserved	R/W		Set bit to 0.
		0	Reserved	R/W		Set bit to 0.
0x01	PWDN Channels	7:0	PWDN CHx	R/W	0x00	Power Down per Channel [7]: CH7 – CHA_3 [6]: CH6 – CHA_2 [5]: CH5 – CHA_1 [4]: CH4 – CHA_0 [3]: CH3 – CHB_3 [2]: CH2 – CHB_2 [1]: CH1 – CHB_1 [0]: CH0 – CHB_0 00'h = all channels enabled FF'h = all channels disabled Note: override PWDN Terminal.

Table 12. SMBus Slave Mode Register Map (continued)

Address	Register Name	Bit	Field	Type	Default	Description
0x02	Override PWDN	7:1	Reserved	R/W	0x00	Set bits to 0.
		0	Override PWDN Terminal			1: Block PWDN Terminal control 0: Allow PWDN Terminal control
0x04	EQ Limiting	7:0	EQ Control	R/W	0x00	CH3 - CH0 EQ Limiting Control [7]: CH7 – CHA_3 (linear only) [6]: CH6 – CHA_2 (linear only) [5]: CH5 – CHA_1 (linear only) [4]: CH4 – CHA_0 (linear only) [3]: CH3 – CHB_3 [2]: CH2 – CHB_2 [1]: CH1 – CHB_1 [0]: CH0 – CHB_0 00'h = all channels linear EQ 0F'h = B-channels limiting EQ Note: These bits do not connect to the A-Channel
0x05	Slave Mode CRC bits	7:0	CRC bits	R/W	0x00	CRC bits [7:0]
0x06	Slave Register Control	7:5	Reserved	R/W	0x10	Set bits to 0.
		4	Reserved			Set bit to 1.
		3	Register Enable			1: Enables high speed channel control via SMBus registers without CRC 0: Channel control via SMBus registers requires correct CRC in Reg 0x05 Note: In order to change VOD, DEM and EQ of the channels in slave mode without also setting CRC each time, set this bit to 1.
		2:0	Reserved			Set bits to 0.
0x07	Digital Reset and Control	7	Reserved	R/W	0x01	Set bit to 0.
		6	Reset Registers			Self clearing reset for SMBus registers. Writing a [1] will return register settings to default values.
		5	Reset SMBus Master			Self clearing reset to SMBus master state machine
		4:0	Reserved			Set bits to 0 0001'b.
0x08	Override Terminal Control	7	Reserved	R/W	0x00	Set bit to 0.
		6	Override SD_TH			1: Block SD_TH Terminal control 0: Allow SD_TH Terminal control
		5	Reserved			Set bit to 0.
		4	Override IDLE			1: IDLE control by registers 0: IDLE control by signal detect Note: These bits do not connect to the A-Channel
		3	Override RXDET			1: Block RXDET Terminal control 0: Allow RXDET Terminal control
		2	Override MODE_B			1: Block MODE_B Terminal control 0: Allow MODE_B Terminal control
		1	Reserved			Set bit to 0.
		0	Reserved			Set bit to 0.
0x0A	Signal Detect Monitor	7:0	IDLE Status	R	0x00	CH7 - CH0 Internal IDLE indicator [7]: CH7 – CHA_3 [6]: CH6 – CHA_2 [5]: CH5 – CHA_1 [4]: CH4 – CHA_0 [3]: CH3 – CHB_3 [2]: CH2 – CHB_2 [1]: CH1 – CHB_1 [0]: CH0 – CHB_0 0'b = Signal Detected at input 1'b = Signal Detected at input Note: These bits only function when MODE_B terminal = FLOAT

Table 12. SMBus Slave Mode Register Map (continued)

Address	Register Name	Bit	Field	Type	Default	Description
0x0E	CH0 - CHB0 IDLE, RXDET	7:6	Reserved	R/W	0x00	Set bits to 0.
		5	IDLE_AUTO			1: Automatic IDLE detect 0: Allow IDLE_SEL control in bit 4 Note: override IDLE control.
		4	IDLE_SEL			1: Output is MUTED (electrical idle) 0: Output is ON Note: override IDLE control.
		3:2	RXDET			00: Input is high-z impedance 01: Auto RX-Detect, outputs test every 12 ms for 600 ms (50 times) then stops; termination is high-z until detection; once detected input termination is 50 Ω 10: Auto RX-Detect, outputs test every 12 ms until detection occurs; termination is high-z until detection; once detected input termination is 50 Ω 11: Input is 50 Ω Note: override RXDET Terminal.
		1:0	Reserved			Set bits to 0.
0x0F	CH0 - CHB0 EQ	7:0	EQ Control	R/W	0x2F	INB_0 EQ Control - total of 256 levels. See Table 5 .
0x10	CH0 - CHB_0 VOD	7	Short Circuit Protection	R/W	0xAD	1: Enable the short circuit protection 0: Disable the short circuit protection
		6	MODE_SEL			1: PCIe Gen 1/2 0: SAS-3 and PCIe Gen 3 Note: override the MODE_B Terminal.
		5:3	Reserved			Set bits to default value - 101.
		2:0	VOD Control			OUTB_0 VOD Control 000: 0.7 V 001: 0.8 V 010: 0.9 V 011: 1.0 V 100: 1.1 V 101: 1.2 V (default) 110: 1.3 V 111: 1.4 V
0x11	CH0 - CHB_0 DEM	7	RXDET STATUS	R	0x02	Observation bit for RXDET CH0 - CHB_0. 1: RX = detected 0: RX = not detected
		6:5	MODE_DET STATUS	R		Observation bit for MODE_DET CH0 - CHB_0. 00: GEN1 (2.5G data-rate) 01: GEN2 (5G data-rate) 11: GEN3 (8G+ data-rate) Note: Only functions when MODE_B Terminal = Automatic
		4:3	Reserved	R/W		Set bits to 0.
		2:0	DEM Control	R/W		OUTB_0 DEM Control 000: 0 dB 001: -1.5 dB 010: -3.5 dB (default) 011: -5 dB 100: -6 dB 101: -8 dB 110: -9 dB 111: -12 dB

Table 12. SMBus Slave Mode Register Map (continued)

Address	Register Name	Bit	Field	Type	Default	Description
0x12	CH0 - CHB_0 SD Threshold	7:4	Reserved	R/W	0x00	Set bits to 0.
		3:2	IDLE tha			Assert threshold (1010 pattern 12 Gbps) 00 = 50 mVp-p (default) 01 = 40 mVp-p 10 = 75 mVp-p 11 = 58 mVp-p Note: override the SD_TH Terminal using 0x08[6].
		1:0	IDLE thd			De-assert threshold (1010 pattern 12 Gbps) 00 = 37 mVp-p (default) 01 = 22 mVp-p 10 = 55 mVp-p 11 = 45 mVp-p Note: override the SD_TH Terminal using 0x08[6].
0x15	CH1 - CHB_1 IDLE, RXDET	7:6	Reserved	R/W	0x00	Set bits to 0.
		5	IDLE_AUTO			1: Automatic IDLE detect 0: Allow IDLE_SEL control in bit 4 Note: override IDLE control.
		4	IDLE_SEL			1: Output is MUTED (electrical idle) 0: Output is ON Note: override IDLE control.
		3:2	RXDET			00: Input is high-z impedance 01: Auto RX-Detect, outputs test every 12 ms for 600 ms (50 times) then stops; termination is high-z until detection; once detected input termination is 50 Ω 10: Auto RX-Detect, outputs test every 12 ms until detection occurs; termination is high-z until detection; once detected input termination is 50 Ω 11: Input is 50 Ω Note: override RXDET Terminal.
		1:0	Reserved			Set bits to 0.
0x16	CH1 - CHB_1 EQ	7:0	EQ Control	R/W	0x2F	INB_1 EQ Control - total of 256 levels. See Table 5 .
0x17	CH1 - CHB_1 VOD	7	Short Circuit Protection	R/W	0xAD	1: Enable the short circuit protection 0: Disable the short circuit protection
		6	MODE_SEL			1: Gen 1/2, 0: SAS-3 and PCIe Gen 3 Note: override the MODE_B Terminal.
		5:3	Reserved			Set bits to default value - 101.
		2:0	VOD Control			OUTB_1 VOD Control 000: 0.7 V 001: 0.8 V 010: 0.9 V 011: 1.0 V 100: 1.1 V 101: 1.2 V (default) 110: 1.3 V 111: 1.4 V

Table 12. SMBus Slave Mode Register Map (continued)

Address	Register Name	Bit	Field	Type	Default	Description
0x18	CH1 - CHB_1 DEM	7	RXDET STATUS	R	0x02	Observation bit for RXDET CH1 - CHB_1. 1: RX = detected 0: RX = not detected
		6:5	MODE_DET STATUS	R		Observation bit for MODE_DET CH1 - CHB_1. 00: GEN1 (2.5G data-rate) 01: GEN2 (5G data-rate) 11: GEN3 (8G+ data-rate) Note: Only functions when MODE_B Terminal = Automatic
		4:3	Reserved	R/W		Set bits to 0.
		2:0	DEM Control	R/W		OUTB_1 DEM Control 000: 0 dB 001: -1.5 dB 010: -3.5 dB (default) 011: -5 dB 100: -6 dB 101: -8 dB 110: -9 dB 111: -12 dB
0x19	CH1 - CHB_1 SD Threshold	7:4	Reserved	R/W	0x00	Set bits to 0.
		3:2	IDLE tha			Assert threshold (1010 pattern 12 Gbps) 00 = 50 mVp-p (default) 01 = 40 mVp-p 10 = 75 mVp-p 11 = 58 mVp-p Note: override the SD_TH Terminal using 0x08[6].
		1:0	IDLE thd			De-assert threshold (1010 pattern 12 Gbps) 00 = 37 mVp-p (default) 01 = 22 mVp-p 10 = 55 mVp-p 11 = 45 mVp-p Note: override the SD_TH Terminal using 0x08[6].
0x1C	CH2 - CHB_2 IDLE, RXDET	7:6	Reserved	R/W	0x00	Set bits to 0.
		5	IDLE_AUTO			1: Automatic IDLE detect 0: Allow IDLE_SEL control in bit 4 Note: override IDLE control.
		4	IDLE_SEL			1: Output is MUTED (electrical idle) 0: Output is ON Note: override IDLE control.
		3:2	RXDET			00: Input is high-z impedance 01: Auto RX-Detect, outputs test every 12 ms for 600 ms (50 times) then stops; termination is high-z until detection; once detected input termination is 50 Ω 10: Auto RX-Detect, outputs test every 12 ms until detection occurs; termination is high-z until detection; once detected input termination is 50 Ω 11: Input is 50 Ω Note: override RXDET Terminal.
		1:0	Reserved			Set bits to 0.
0x1D	CH2 - CHB2 EQ	7:0	EQ Control	R/W	0x2F	INB_2 EQ Control - total of 256 levels. See Table 5 .

Table 12. SMBus Slave Mode Register Map (continued)

Address	Register Name	Bit	Field	Type	Default	Description
0x1E	CH2 - CHB2 VOD	7	Short Circuit Protection	R/W	0xAD	1: Enable the short circuit protection 0: Disable the short circuit protection
		6	MODE_SEL			1: Gen 1/2, 0: SAS-3 and PCIe Gen 3 Note: override the MODE_B Terminal.
		5:3	Reserved			Set bits to default value - 101.
		2:0	VOD Control			OUTB_2 VOD Control 000: 0.7 V 001: 0.8 V 010: 0.9 V 011: 1.0 V 100: 1.1 V 101: 1.2 V (default) 110: 1.3 V 111: 1.4 V
0x1F	CH2 - CHB_2 DEM	7	RXDET STATUS	R	0x02	Observation bit for RXDET CH2 - CHB_2. 1: RX = detected 0: RX = not detected
		6:5	MODE_DET STATUS	R		Observation bit for MODE_DET CH2 - CHB_2. 00: GEN1 (2.5G data-rate) 01: GEN2 (5G data-rate) 11: GEN3 (8G+ data-rate) Note: Only functions when MODE_B Terminal = Automatic
		4:3	Reserved	R/W		Set bits to 0.
		2:0	DEM Control	R/W		OUTB_2 DEM Control 000: 0 dB 001: -1.5 dB 010: -3.5 dB (default) 011: -5 dB 100: -6 dB 101: -8 dB 110: -9 dB 111: -12 dB
0x20	CH2 - CHB_2 SD Threshold	7:4	Reserved	R/W	0x00	Set bits to 0.
		3:2	IDLE tha			Assert threshold (1010 pattern 12 Gbps) 00 = 50 mVp-p (default) 01 = 40 mVp-p 10 = 75 mVp-p 11 = 58 mVp-p Note: override the SD_TH Terminal using 0x08[6].
		1:0	IDLE thd			De-assert threshold (1010 pattern 12 Gbps) 00 = 37 mVp-p (default) 01 = 22 mVp-p 10 = 55 mVp-p 11 = 45 mVp-p Note: override the SD_TH Terminal using 0x08[6].

Table 12. SMBus Slave Mode Register Map (continued)

Address	Register Name	Bit	Field	Type	Default	Description
0x23	CH3 - CHB_3 IDLE, RXDET	7:6	Reserved	R/W	0x00	Set bits to 0.
		5	IDLE_AUTO			1: Automatic IDLE detect 0: Allow IDLE_SEL control in bit 4 Note: override IDLE control.
		4	IDLE_SEL			1: Output is MUTED (electrical idle) 0: Output is ON Note: override IDLE control.
		3:2	RXDET			00: Input is high-z impedance 01: Auto RX-Detect, outputs test every 12 ms for 600 ms (50 times) then stops; termination is high-z until detection; once detected input termination is 50 Ω 10: Auto RX-Detect, outputs test every 12 ms until detection occurs; termination is high-z until detection; once detected input termination is 50 Ω 11: Input is 50 Ω Note: override RXDET Terminal.
		1:0	Reserved			Set bits to 0.
0x24	CH3 - CHB_3 EQ	7:0	EQ Control	R/W	0x2F	INB_3 EQ Control - total of 256 levels. See Table 5 .
0x25	CH3 - CHB_3 VOD	7	Short Circuit Protection	R/W	0xAD	1: Enable the short circuit protection 0: Disable the short circuit protection
		6	MODE_SEL			1: Gen 1/2, 0: SAS-3 and PCIe Gen 3 Note: override the MODE_B Terminal.
		5:3	Reserved			Set bits to default value - 101.
		2:0	VOD Control			OUTB_3 VOD Control 000: 0.7 V 001: 0.8 V 010: 0.9 V 011: 1.0 V 100: 1.1 V 101: 1.2 V (default) 110: 1.3 V 111: 1.4 V
0x26	CH3 - CHB_3 DEM	7	RXDET STATUS	R	0x02	Observation bit for RXDET CH3 - CHB_3. 1: RX = detected 0: RX = not detected
		6:5	MODE_DET STATUS	R		Observation bit for MODE_DET CH3 - CHB_3. 00: GEN1 (2.5G data-rate) 01: GEN2 (5G data-rate) 11: GEN3 (8G+ data-rate) Note: Only functions when MODE_B Terminal = Automatic
		4:3	Reserved	R/W		Set bits to 0.
		2:0	DEM Control	R/W		OUTB_3 DEM Control 000: 0 dB 001: -1.5 dB 010: -3.5 dB (default) 011: -5 dB 100: -6 dB 101: -8 dB 110: -9 dB 111: -12 dB

Table 12. SMBus Slave Mode Register Map (continued)

Address	Register Name	Bit	Field	Type	Default	Description
0x27	CH3 - CHB_3 SD Threshold	7:4	Reserved	R/W	0x00	Set bits to 0.
		3:2	IDLE tha			Assert threshold (1010 pattern 12 Gbps) 00 = 50 mVp-p (default) 01 = 40 mVp-p 10 = 75 mVp-p 11 = 58 mVp-p Note: override the SD_TH Terminal using 0x08[6].
		1:0	IDLE thd			De-assert threshold (1010 pattern 12 Gbps) 00 = 37 mVp-p (default) 01 = 22 mVp-p 10 = 55 mVp-p 11 = 45 mVp-p Note: override the SD_TH Terminal using 0x08[6].
0x28	Signal Detect Control	7:6	Reserved	R/W	0x0C	Set bits to 0.
		5:4	High IDLE			Enable higher range of Signal Detect Thresholds [5]: CH0 - CH3 [4]: CH4 - CH7
		3:2	Fast IDLE			Enable Fast OOB response [3]: CH0 - CH3 [2]: CH4 - CH7
		1:0	Reduced SD Gain			Enable reduced Signal Detect Gain [1]: CH0 - CH3 [0]: CH4 - CH7
0x2B	CH4 - CHA_0 RXDET	7:4	Reserved	R/W	0x00	Set bits to 0.
		3:2	RXDET			00: Input is high-z impedance 01: Auto RX-Detect, outputs test every 12 ms for 600 ms (50 times) then stops; termination is high-z until detection; once detected input termination is 50 Ω 10: Auto RX-Detect, outputs test every 12 ms until detection occurs; termination is high-z until detection; once detected input termination is 50 Ω 11: Input is 50 Ω Note: override RXDET Terminal.
		1:0	Reserved			Set bits to 0.
0x2C	CH4 - CHA_0 EQ	7:0	EQ Control	R/W	0x2F	INA_0 EQ Control - total of 4 levels. See Table 6 .
0x2D	CH4 - CHA_0 VOD	7	Short Circuit Protection	R/W	0xAD	1: Enable the short circuit protection 0: Disable the short circuit protection
		6	Reserved			Set bit to 0.
		5:3	Reserved			Set bits to default value - 101.
		2:0	VOD Control			OUTA_0 VOD Control 000: 0.65 001: 0.70 010: 0.78 011: 0.83 100: 0.88 101: 0.91 (Default) 110: 1.00 111: 1.05 (Recommended for SAS)

Table 12. SMBus Slave Mode Register Map (continued)

Address	Register Name	Bit	Field	Type	Default	Description
0x2E	CH4 - CHA_0 DEM	7	RXDET STATUS	R	0x02	Observation bit for RXDET CH4 - CHA_0. 1: RX = detected 0: RX = not detected
		6:5	MODE_DET STATUS	R		Observation bit for MODE_DET CH4 - CHA_0. 00: GEN1 (2.5G data-rate) 01: GEN2 (5G data-rate) 11: GEN3 (8G+ data-rate) Note: Only functions when MODE_B Terminal = Automatic
		4:3	Reserved	R/W		Set bits to 0.
		2:0	DEM Control	R/W		OUTA_0 DEM Control (010'b Default) This control does not provide a DEM function for A- Channel outputs. Based on system interoperability testing it is recommended to set these bits to 000'b for SAS and PCIe applications.
0x2F	CH4 - CHA_0 SD Threshold	7:4	Reserved	R/W	0x00	Set bits to 0.
		3:2	IDLE tha			Assert threshold (1010 pattern 12 Gbps) 00 = 50 mVp-p (default) 01 = 40 mVp-p 10 = 75 mVp-p 11 = 58 mVp-p Note: override the SD_TH Terminal using 0x08[6].
		1:0	IDLE thd			De-assert threshold (1010 pattern 12 Gbps) 00 = 37 mVp-p (default) 01 = 22 mVp-p 10 = 55 mVp-p 11 = 45 mVp-p Note: override the SD_TH Terminal using 0x08[6].
0x32	CH5 - CHA_1 RXDET	7:4	Reserved	R/W	0x00	Set bits to 0.
		3:2	RXDET			00: Input is high-z impedance 01: Auto RX-Detect, outputs test every 12 ms for 600 ms (50 times) then stops; termination is high-z until detection; once detected input termination is 50 Ω 10: Auto RX-Detect, outputs test every 12 ms until detection occurs; termination is high-z until detection; once detected input termination is 50 Ω 11: Input is 50 Ω Note: override RXDET Terminal.
		1:0	Reserved			Set bits to 0.
0x33	CH5 - CHA_1 EQ	7:0	EQ Control	R/W	0x2F	INA_1 EQ Control - total of 4 levels. See Table 6 .
0x34	CH5 - CHA_1 VOD	7	Short Circuit Protection	R/W	0xAD	1: Enable the short circuit protection 0: Disable the short circuit protection
		6	Reserved			Set bit to 0.
		5:3	Reserved			Set bits to default value - 101.
		2:0	VOD Control			OUTA_1 VOD Control 000: 0.65 001: 0.70 010: 0.78 011: 0.83 100: 0.88 101: 0.91 (Default) 110: 1.00 111: 1.05 (Recommended for SAS)

Table 12. SMBus Slave Mode Register Map (continued)

Address	Register Name	Bit	Field	Type	Default	Description
0x35	CH5 - CHA1 DEM	7	RXDET STATUS	R	0x02	Observation bit for RXDET CH5 - CHA_1. 1: RX = detected 0: RX = not detected
		6:5	MODE_DET STATUS	R		Observation bit for MODE_DET CH5 - CHA_1. 00: GEN1 (2.5G data-rate) 01: GEN2 (5G data-rate) 11: GEN3 (8G+ data-rate) Note: Only functions when MODE_B Terminal = Automatic
		4:3	Reserved	R/W		Set bits to 0.
		2:0	DEM Control	R/W		OUTA_1 DEM Control (010'b Default) This control does not provide a DEM function for A- Channel outputs. Based on system interoperability testing it is recommended to set these bits to 000'b for SAS and PCIe applications.
0x36	CH5 - CHA_1 SD Threshold	7:4	Reserved	R/W	0x00	Set bits to 0.
		3:2	IDLE tha			Assert threshold (1010 pattern 12 Gbps) 00 = 50 mVp-p (default) 01 = 40 mVp-p 10 = 75 mVp-p 11 = 58 mVp-p Note: override the SD_TH Terminal using 0x08[6].
		1:0	IDLE thd			De-assert threshold (1010 pattern 12 Gbps) 00 = 37 mVp-p (default) 01 = 22 mVp-p 10 = 55 mVp-p 11 = 45 mVp-p Note: override the SD_TH Terminal using 0x08[6].
0x39	CH6 - CHA_2 RXDET	7:4	Reserved	R/W	0x00	Set bits to 0.
		3:2	RXDET			00: Input is high-z impedance 01: Auto RX-Detect, outputs test every 12 ms for 600 ms (50 times) then stops; termination is high-z until detection; once detected input termination is 50 Ω 10: Auto RX-Detect, outputs test every 12 ms until detection occurs; termination is high-z until detection; once detected input termination is 50 Ω 11: Input is 50 Ω Note: override RXDET Terminal.
		1:0	Reserved			Set bits to 0.
0x3A	CH6 - CHA_2 EQ	7:0	EQ Control	R/W	0x2F	INA_2 EQ Control - total of 4 levels. See Table 6 .
0x3B	CH6 - CHA_2 VOD	7	Short Circuit Protection	R/W	0xAD	1: Enable the short circuit protection 0: Disable the short circuit protection
		6	Reserved			set bit to 0.
		5:3	Reserved			Set bits to default value - 101.
		2:0	VOD Control			OUTA_2 VOD Control: VOD / VID Ratio 000: 0.65 001: 0.70 010: 0.78 011: 0.83 100: 0.88 101: 0.91 (Default) 110: 1.00 111: 1.05 (Recommended for SAS)

Table 12. SMBus Slave Mode Register Map (continued)

Address	Register Name	Bit	Field	Type	Default	Description
0x3C	CH6 - CHA_2 DEM	7	RXDET STATUS	R	0x02	Observation bit for RXDET CH6 - CHA_2. 1: RX = detected 0: RX = not detected
		6:5	MODE_DET STATUS	R		Observation bit for MODE_DET CH6 - CHA_2. 00: GEN1 (2.5G data-rate) 01: GEN2 (5G data-rate) 11: GEN3 (8G+ data-rate) Note: Only functions when MODE_B Terminal = Automatic
		4:3	Reserved	R/W		Set bits to 0.
		2:0	DEM Control	R/W		OUTA_2 DEM Control (010'b Default) This control does not provide a DEM function for A- Channel outputs. Based on system interoperability testing it is recommended to set these bits to 000'b for SAS and PCIe applications.
0x3D	CH6 - CHA_2 SD Threshold	7:4	Reserved	R/W	0x00	Set bits to 0.
		3:2	IDLE tha			Assert threshold (1010 pattern 12 Gbps) 00 = 50 mVp-p (default) 01 = 40 mVp-p 10 = 75 mVp-p 11 = 58 mVp-p Note: override the SD_TH Terminal using 0x08[6].
		1:0	IDLE thd			De-assert threshold (1010 pattern 12 Gbps) 00 = 37 mVp-p (default) 01 = 22 mVp-p 10 = 55 mVp-p 11 = 45 mVp-p Note: override the SD_TH Terminal using 0x08[6].
0x40	CH7 - CHA_3 RXDET	7:4	Reserved	R/W	0x00	Set bits to 0.
		3:2	RXDET			00: Input is high-z impedance 01: Auto RX-Detect, outputs test every 12 ms for 600 ms (50 times) then stops; termination is high-z until detection; once detected input termination is 50 Ω 10: Auto RX-Detect, outputs test every 12 ms until detection occurs; termination is high-z until detection; once detected input termination is 50 Ω 11: Input is 50 Ω Note: override RXDET Terminal.
		1:0	Reserved			Set bits to 0.
0x41	CH7 - CHA_3 EQ	7:0	EQ Control	R/W	0x2F	INA_3 EQ Control - total of 4 levels. See Table 6 .
0x42	CH7 - CHA_3 VOD	7	Short Circuit Protection	R/W	0xAD	1: Enable the short circuit protection 0: Disable the short circuit protection
		6	Reserved			Set bit to 0.
		5:3	Reserved			Set bits to default value - 101.
		2:0	VOD Control			OUTA_3 VOD Control: VOD / VID Ratio 000: 0.65 001: 0.70 010: 0.78 011: 0.83 100: 0.88 101: 0.91 (Default) 110: 1.00 111: 1.05 (Recommended for SAS)

Table 12. SMBus Slave Mode Register Map (continued)

Address	Register Name	Bit	Field	Type	Default	Description
0x43	CH7 - CHA3 DEM	7	RXDET STATUS	R	0x02	Observation bit for RXDET CH7 - CHA3. 1: RX = detected 0: RX = not detected
		6:5	MODE_DET STATUS	R		Observation bit for MODE_DET CH7 - CHA3. 00: GEN1 (2.5G data-rate) 01: GEN2 (5G data-rate) 11: GEN3 (8G+ data-rate) Note: Only functions when MODE_B Terminal = Automatic
		4:3	Reserved	R/W		Set bits to 0.
		2:0	DEM Control	R/W		OUTA_3 DEM Control (010'b Default) This control does not provide a DEM function for A- Channel outputs. Based on system interoperability testing it is recommended to set these bits to 000'b for SAS and PCIe applications.
0x44	CH7 - CHA3 SD Threshold	7:4	Reserved	R/W	0x00	Set bits to 0.
		3:2	IDLE tha			Assert threshold (1010 pattern 12 Gbps) 00 = 50 mVp-p (default) 01 = 40 mVp-p 10 = 75 mVp-p 11 = 58 mVp-p Note: override the SD_TH Terminal using 0x08[6].
		1:0	IDLE thd			De-assert threshold (1010 pattern 12 Gbps) 00 = 37 mVp-p (default) 01 = 22 mVp-p 10 = 55 mVp-p 11 = 45 mVp-p Note: override the SD_TH Terminal using 0x08[6].
0x51	Device ID	7:5	VERSION	R	0x84	100'b
		4:0	ID			00100'b

8 Applications and Implementation

8.1 Application Information

8.1.1 Signal Integrity in SAS-3 Applications

SAS-3 specifications have fully specified Rx-Tx training as a means to establish and optimize signal conditioning settings at the 12.0 Gbps data-rate. The DS125BR401A works to extend the reach possible by adding active linear equalization to the channel, boosting attenuated signals so that they can be more easily recovered at the SAS-3 Rx. The A-Channel outputs are specially designed to be transparent to TX FIR signaling passing this information critical for optimal link training to the SAS-3 Rx. The A-Channel device settings used in a SAS-3 environment are EQ = Level 4, DEMA1 = 1 and DEMA0 = 0 in Terminal mode or EQ = 03'h, VOD = 111'b, and DEM = 000'b in SMBus mode.

8.1.2 RX-Detect in SAS/SATA Applications

Unlike PCIe systems, SAS/SATA systems use a low speed Out-Of-Band or OOB communications sequence to detect and communicate between SAS Controllers/Expanders and target drives. This communication eliminates the need to detect for endpoints like PCIe. For SAS systems, it is recommended to tie the RXDET Terminal high. This will ensure any OOB sequences sent from the Controller/Expander will reach the target drive without any additional latency due to the termination detection sequence defined by PCIe.

8.1.3 Signal Integrity in PCIe Applications

When using the DS125BR401A in PCIe GEN-3 systems, there are specific signal integrity settings to ensure signal integrity margin. The settings were optimized by system bench testing. Please contact your field representative for more information regarding the testing completed to achieve these settings.

For tuning the in the downstream direction (from CPU to EP).

- EQB: use the guidelines outlined in [Table 5](#) and [Table 6](#).
- EQA: EQ = 11'b or EQA0 = 1.
- DEMB: Use the guidelines outlined in [Table 7](#).
- DEMA set to 000'b in SMBus Mode.
- VODB: use the guidelines outlined in [Table 7](#).
- VODA: SMBus = 111'b, Terminal Control: DEMA1=1, DEMA0 = 0

For tuning in the upstream direction (from EP to CPU).

- B-Channel:
 - EQ: use the guidelines outlined in [Table 5](#) and [Table 6](#).
 - DEM for trace lengths < 15in set to -3.5 dB
 - DEM for trace lengths > 15in set to -6 dB
 - VOD: Set to 900 mV
- A-Channel:
 - EQ = 11'b or EQA0 = 1.
 - DEM for trace lengths < 15in set to 000'b in SMBus Mode.
 - DEM for trace lengths > 15in set to 000'b in SMBus Mode.
 - VOD: SMBus = 111'b, Terminal Control: DEMA1=1, DEMA0 = 0

8.1.4 MODE operation with SMBus Registers

When in SMBus mode (Slave or Master), the MODE Terminal retains control of the output driver characteristics. In order to override this control function, Register 0x08[2] must be written with a "1". Writing this bit enables MODE control of each channel individually using the channel registers defined in [Table 12](#).

8.2 Typical Application

SAS-3 specifications have fully specified Rx-Tx training as a means to establish and optimize signal conditioning settings at the 12.0 Gbps data-rate. The DS125BR401A works to extend the reach possible by adding active linear equalization to the channel, boosting attenuated signals so that they can be more easily recovered at the SAS-3 Rx. The A-Channel outputs are specially designed to be transparent to TX FIR signaling passing this information critical for optimal link training to the SAS-3 Rx. The A-Channel device settings used in a SAS-3 environment are EQ = Level 4, DEMA1 = 1 and DEMA0 = 0 in Terminal mode or EQ = 03'h, VOD = 111'b, and DEM = 000'b in SMBus mode.

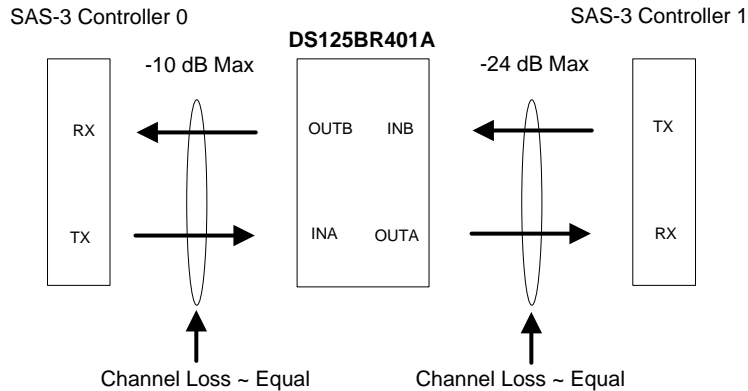

Figure 8. Typical System Configuration

8.2.1 Design Requirements

As with any high speed design, there are many factors which influence the overall performance, this section lists some critical areas for consideration and study.

- Limit the maximum losses according to [Figure 8](#).
- Utilize 100Ω impedance traces. Generally these are very loosely coupled to ease routing length differences.
- Place AC-coupling capacitors near to the receiver end of each channel segment to minimize reflections.
- The maximum body size for AC-coupling capacitors is 0402.
- Back-drill connector vias and signal vias to minimize stub length
- Use Reference plane vias to ensure a low inductance path for the return current.

8.2.2 Detailed Design Procedure

The DS125BR401A is designed to be placed at an offset location with respect to the overall channel attenuation, a maximum attenuation of 10 dB on the INA side and 22 dB on the INB side. The input channel segment with the lowest attenuation should always be connected to the INA port. This drives different design constraints and settings to the A-Channel and B-Channel sides. The A-Channel device settings used in a SAS-3 environment are EQ = Level 4, DEMA1 = 1 and DEMA0 = 0 in Terminal mode or EQ = 03'h, VOD = 111'b, and DEM = 000'b in SMBus mode. This setting has proven to give the best overall SAS-3 extension for all configurations tested. The B-Channel has a larger signal gain than the A-Channel and the capability to add even higher levels of CTLE if required. In even the longer channel configurations with attenuation on the B-Channel inputs of ~ 20 dB @ 6 GHz can recover a solid eye opening with EQB = Level 1, DEMA1 = FLOAT and DEMA0 = R in Terminal mode or EQ = 00'h, VOD = 101'b, and DEM = 000'b in SMBus mode.

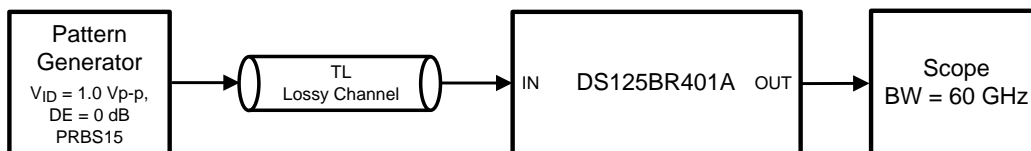

Figure 9. Test Setup Connections Diagram

Typical Application (continued)

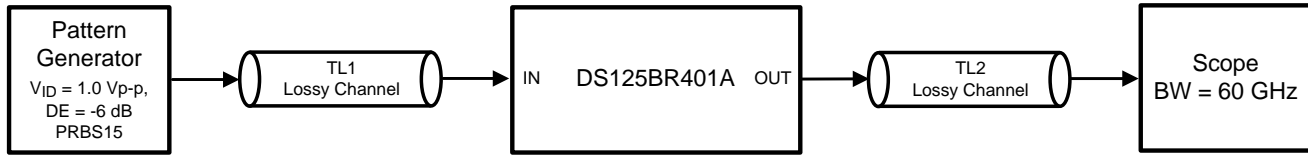
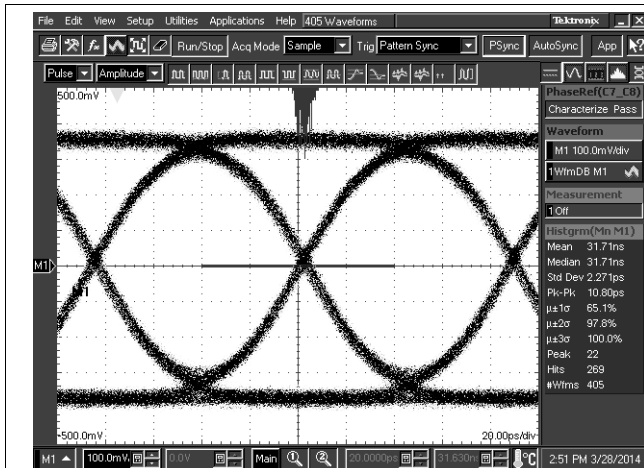
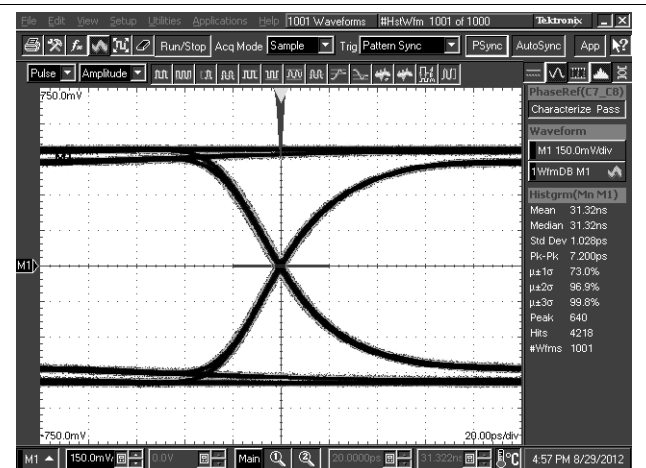

Figure 10. Test Setup Connections Diagram

8.2.3 Application Performance Plots



DS125BR401A settings: EQA[1:0] = 0, R = 01'h, DEMA[1:0] = 1, 0
Figure 11. TLine = 5 Inch 5-Mil FR4 Trace, 12 Gbps



DS125BR401A settings: EQB[1:0] = 0, F = 02'h, DEMB[1:0] = 0, 1
Figure 12. TLine = 10 Inch 5-Mil FR4 Trace, 6 Gbps

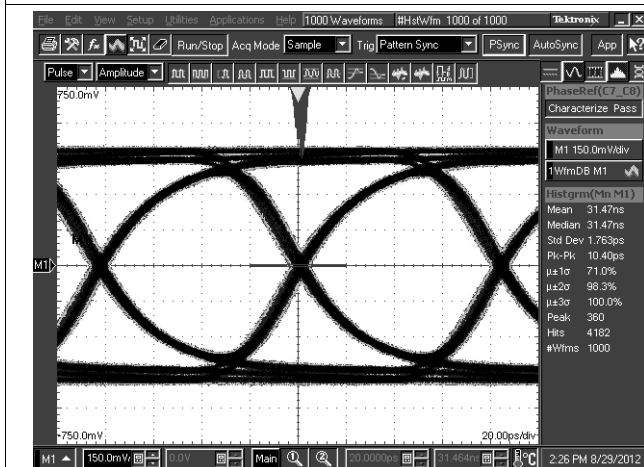

DS125BR401A settings: EQB[1:0] = 0, R = 01'h, DEMB[1:0] = 0, 1
Figure 13. TLine = 10 Inch 5-Mil FR4 Trace, 12 Gbps

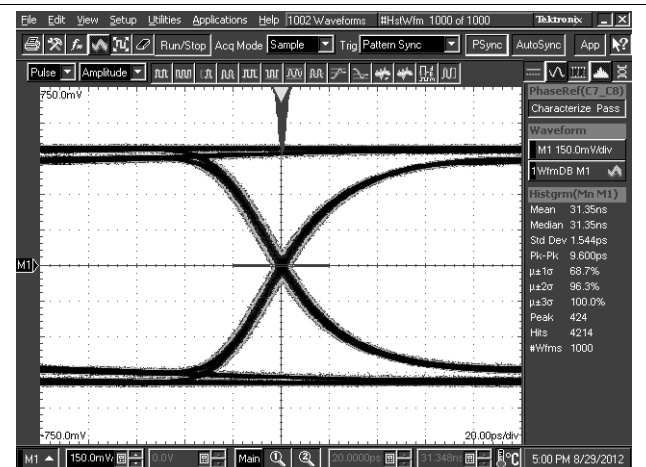

DS125BR401A settings: EQB[1:0] = 0, 1 = 03'h, DEMB[1:0] = 0, 1
Figure 14. TLine = 20 Inch 5-Mil FR4 Trace, 6 Gbps

Typical Application (continued)

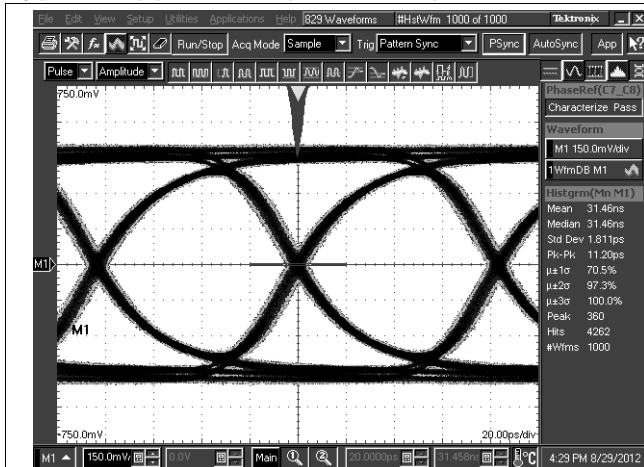

DS125BR401A settings: EQB[1:0] = 0, 1 = 03'h, DEMB[1:0] = 0, 1
Figure 15. Tl = 20 Inch 5-Mil FR4 Trace, 12 Gbps

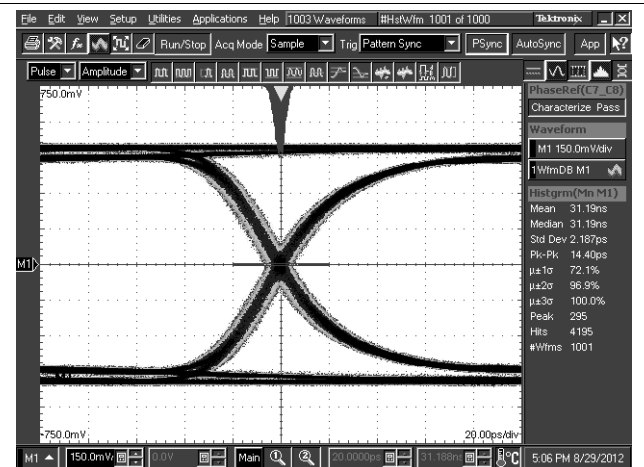

DS125BR401A settings: EQB[1:0] = R, 0 = 07'h, DEMB[1:0] = 0, 1
Figure 16. TLine = 30 Inch 5-Mil FR4 Trace, 6 Gbps

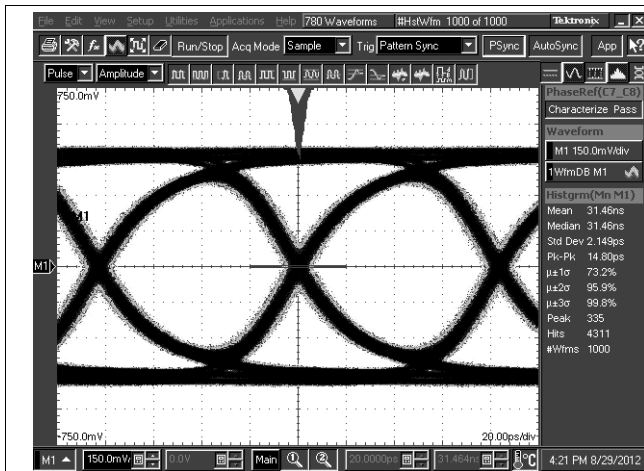

DS125BR401A settings: EQB[1:0] = R, 0 = 07'h, DEMB[1:0] = 0, 1
Figure 17. Tl = 30 Inch 5-Mil FR4 Trace, 12 Gbps

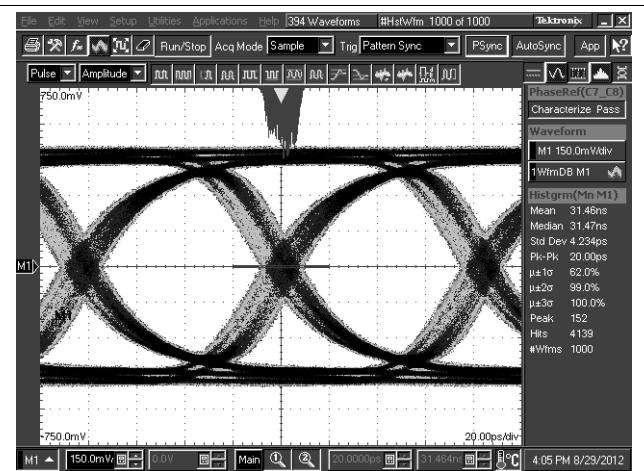

DS125BR401A settings: EQB[1:0] = R, 0 = 07'h, DEMB[1:0] = 0, 1
Figure 18. T11 = 5-Meter 30-Awg 100 Ohm Twin-Axial Cable, 12 Gbps

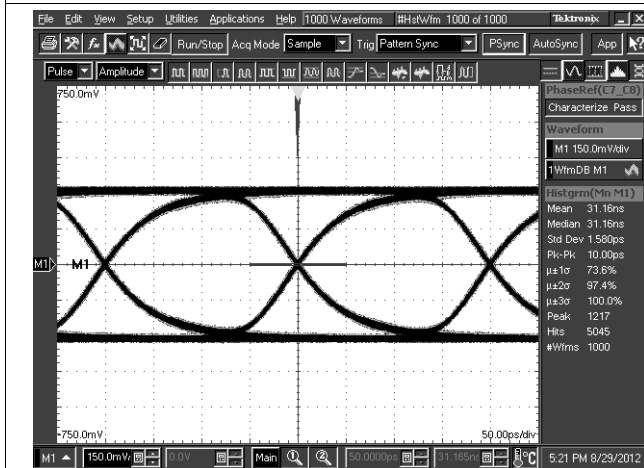

DS125BR401A settings: EQ[1:0] = 0, 1 = 03'h, DEMB[1:0] = R, 0
Figure 19. TLine1 = 20 Inch 5-Mil FR4 Trace, TLine2 = 10 Inch 5-Mil FR4 Trace, 5 Gbps

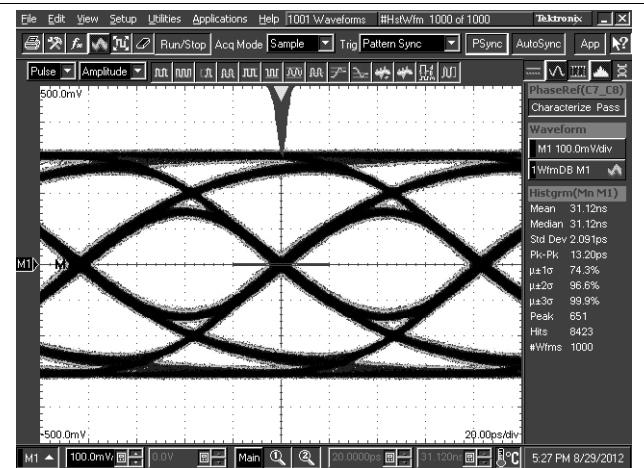

DS125BR401A settings: EQ[1:0] = R, 1 = 0F'h, DEM[1:0] = R, 0
Figure 20. TLine1 = 20 Inch 5-Mil FR4 Trace, TLine2 = 10 Inch 5-Mil FR4 Trace, 12 Gbps

9 Power Supply Recommendations

Two approaches are recommended to ensure that the DS125BR401A is provided with an adequate power supply. First, the supply (VDD) and ground (GND) Terminals should be connected to power planes routed on adjacent layers of the printed circuit board. The layer thickness of the dielectric should be minimized so that the V_{DD} and GND planes create a low inductance supply with distributed capacitance. Second, careful attention to supply bypassing through the proper use of bypass capacitors is required. A 0.1µF bypass capacitor should be connected to each V_{DD} Terminal such that the capacitor is placed as close as possible to the DS125BR401A. Smaller body size capacitors can help facilitate proper component placement. Additionally, capacitor with capacitance in the range of 1 µF to 10 µF should be incorporated in the power supply bypassing design as well. These capacitors can be either tantalum or an ultra-low ESR ceramic.

The DS125BR401A has an optional internal voltage regulator to provide the 2.5V supply to the device. In 3.3V mode operation, the VIN Terminal = 3.3V is used to supply power to the device. The internal regulator will provide the 2.5V to the VDD Terminals of the device and a 0.1µF cap is needed at each of the 5 VDD Terminals for power supply de-coupling (total capacitance should equal 0.5 µF). The VDD_SEL Terminal must be tied to GND to enable the internal regulator. In 2.5V mode operation, the VIN Terminal should be left open and 2.5V supply must be applied to the 5 VDD Terminals to power the device. The VDD_SEL Terminal must be left open (no connect) to disable the internal regulator.

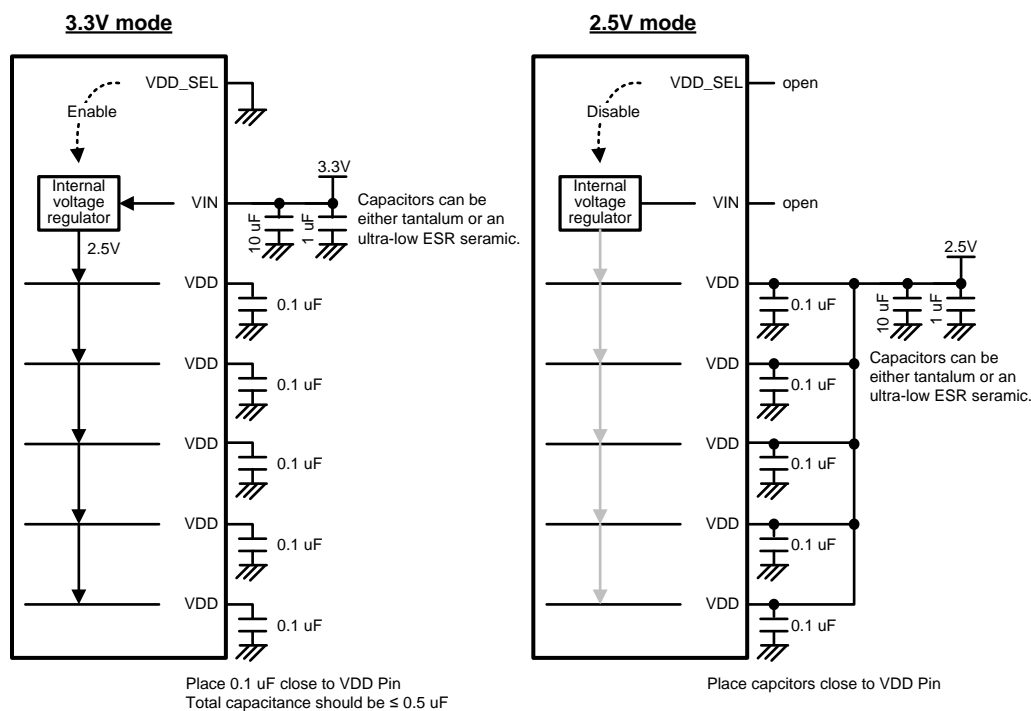

Figure 21. 3.3V or 2.5V Supply Connection Diagram

10 Layout

10.1 Layout Guidelines

The CML inputs and outputs have been optimized to work with interconnects using a controlled differential impedance of 100Ω. It is preferable to route differential lines exclusively on one layer of the board, particularly for the input traces. The use of vias should be avoided if possible. If vias must be used, they should be used sparingly and must be placed symmetrically for each side of a given differential pair. Whenever differential vias are used the layout must also provide for a low inductance path for the return currents as well. Route the differential signals away from other signals and noise sources on the printed circuit board. See AN-1187 “Leadless Leadframe Package (LLP) Application Report” (literature number [SNOA401](#)) for additional information on QFN (WQFN) packages.

10.2 Layout Example

To minimize the effects of crosstalk, a 5:1 ratio or greater should be maintained between inter-pair and intra-pair spacing.

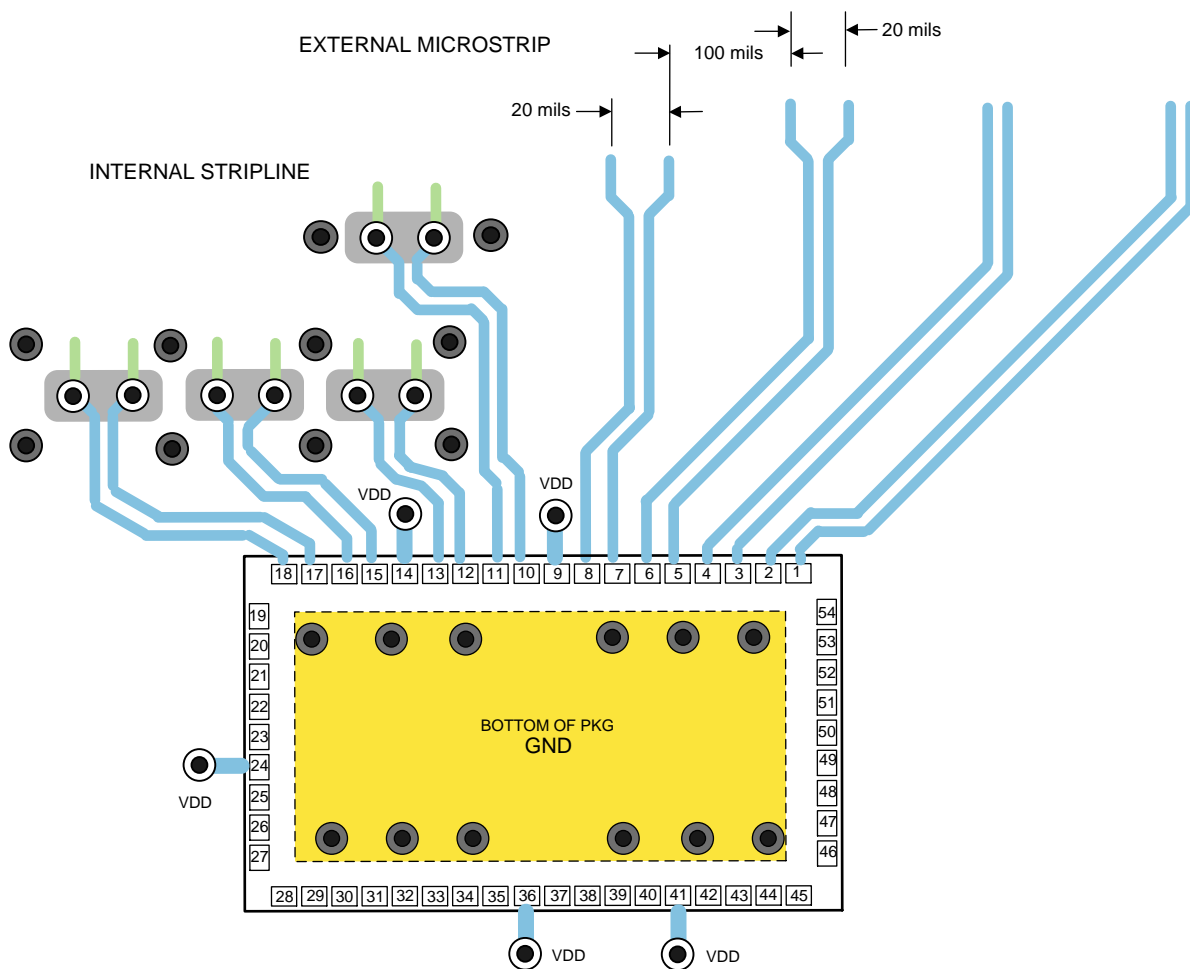

Figure 22. Typical Routing Options

The graphic shown above depicts different transmission line topologies which can be used in various combinations to achieve the optimal system performance. Impedance discontinuities at the differential via can be minimized or eliminated by increasing the swell around each hole and providing for a low inductance return current path. When the via structure is associated with thick backplane PCB, further optimization such as back drilling is often used to reduce the detrimental high frequency effects of stubs on the signal path.

11 器件和文档支持

11.1 Trademarks

All trademarks are the property of their respective owners.

11.2 Electrostatic Discharge Caution



These devices have limited built-in ESD protection. The leads should be shorted together or the device placed in conductive foam during storage or handling to prevent electrostatic damage to the MOS gates.

11.3 Glossary

[SLYZ022](#) — *TI Glossary*.

This glossary lists and explains terms, acronyms and definitions.

12 机械封装和可订购信息

以下页中包括机械封装和可订购信息。 这些信息是针对指定器件可提供的最新数据。 这些数据会在无通知且不对本文档进行修订的情况下发生改变。 欲获得该数据表的浏览器版本，请查阅左侧的导航栏。

PACKAGING INFORMATION

Orderable Device	Status (1)	Package Type	Package Drawing	Pins	Package Qty	Eco Plan (2)	Lead finish/ Ball material (6)	MSL Peak Temp (3)	Op Temp (°C)	Device Marking (4/5)	Samples
DS125BR401ANJYR	ACTIVE	WQFN	NJY	54	2000	RoHS & Green	SN	Level-2-260C-1 YEAR	-40 to 85	DS125BR401A	Samples
DS125BR401ANJYT	ACTIVE	WQFN	NJY	54	250	RoHS & Green	SN	Level-2-260C-1 YEAR	-40 to 85	DS125BR401A	Samples

(1) The marketing status values are defined as follows:

ACTIVE: Product device recommended for new designs.

LIFEBUY: TI has announced that the device will be discontinued, and a lifetime-buy period is in effect.

NRND: Not recommended for new designs. Device is in production to support existing customers, but TI does not recommend using this part in a new design.

PREVIEW: Device has been announced but is not in production. Samples may or may not be available.

OBSOLETE: TI has discontinued the production of the device.

(2) **RoHS:** TI defines "RoHS" to mean semiconductor products that are compliant with the current EU RoHS requirements for all 10 RoHS substances, including the requirement that RoHS substance do not exceed 0.1% by weight in homogeneous materials. Where designed to be soldered at high temperatures, "RoHS" products are suitable for use in specified lead-free processes. TI may reference these types of products as "Pb-Free".

RoHS Exempt: TI defines "RoHS Exempt" to mean products that contain lead but are compliant with EU RoHS pursuant to a specific EU RoHS exemption.

Green: TI defines "Green" to mean the content of Chlorine (Cl) and Bromine (Br) based flame retardants meet JS709B low halogen requirements of <=1000ppm threshold. Antimony trioxide based flame retardants must also meet the <=1000ppm threshold requirement.

(3) MSL, Peak Temp. - The Moisture Sensitivity Level rating according to the JEDEC industry standard classifications, and peak solder temperature.

(4) There may be additional marking, which relates to the logo, the lot trace code information, or the environmental category on the device.

(5) Multiple Device Markings will be inside parentheses. Only one Device Marking contained in parentheses and separated by a "~" will appear on a device. If a line is indented then it is a continuation of the previous line and the two combined represent the entire Device Marking for that device.

(6) Lead finish/Ball material - Orderable Devices may have multiple material finish options. Finish options are separated by a vertical ruled line. Lead finish/Ball material values may wrap to two lines if the finish value exceeds the maximum column width.

Important Information and Disclaimer:The information provided on this page represents TI's knowledge and belief as of the date that it is provided. TI bases its knowledge and belief on information provided by third parties, and makes no representation or warranty as to the accuracy of such information. Efforts are underway to better integrate information from third parties. TI has taken and continues to take reasonable steps to provide representative and accurate information but may not have conducted destructive testing or chemical analysis on incoming materials and chemicals. TI and TI suppliers consider certain information to be proprietary, and thus CAS numbers and other limited information may not be available for release.

In no event shall TI's liability arising out of such information exceed the total purchase price of the TI part(s) at issue in this document sold by TI to Customer on an annual basis.

TAPE AND REEL INFORMATION

QUADRANT ASSIGNMENTS FOR PIN 1 ORIENTATION IN TAPE

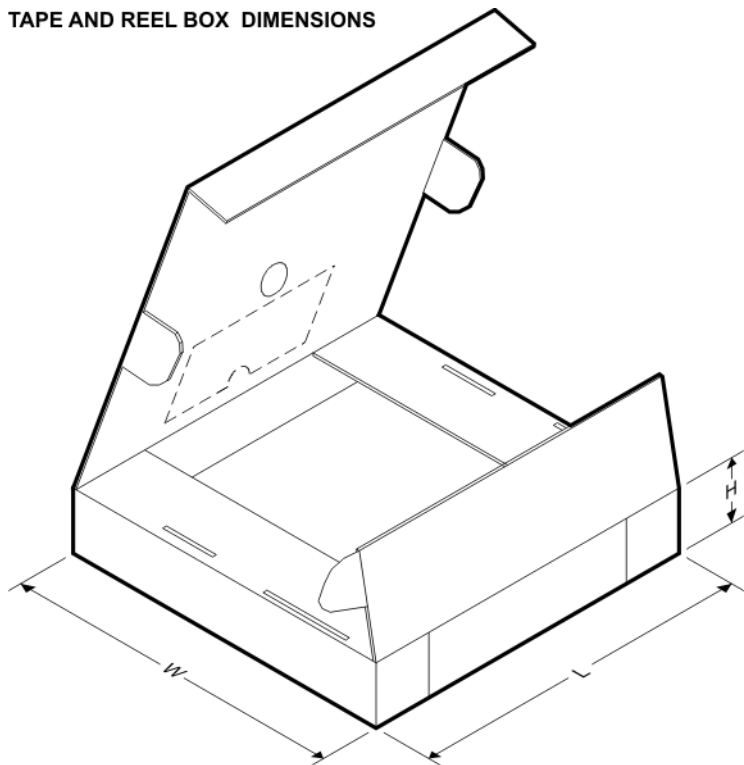

*All dimensions are nominal

Device	Package Type	Package Drawing	Pins	SPQ	Reel Diameter (mm)	Reel Width W1 (mm)	A0 (mm)	B0 (mm)	K0 (mm)	P1 (mm)	W (mm)	Pin1 Quadrant
DS125BR401ANJYR	WQFN	NJY	54	2000	330.0	16.4	5.8	10.3	1.0	12.0	16.0	Q1
DS125BR401ANJYT	WQFN	NJY	54	250	178.0	16.4	5.8	10.3	1.0	12.0	16.0	Q1

TAPE AND REEL BOX DIMENSIONS

*All dimensions are nominal

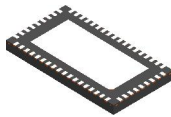
Device	Package Type	Package Drawing	Pins	SPQ	Length (mm)	Width (mm)	Height (mm)
DS125BR401ANJYR	WQFN	NJY	54	2000	853.0	449.0	35.0
DS125BR401ANJYT	WQFN	NJY	54	250	208.0	191.0	35.0



NJY0054A

WQFN

WQFN

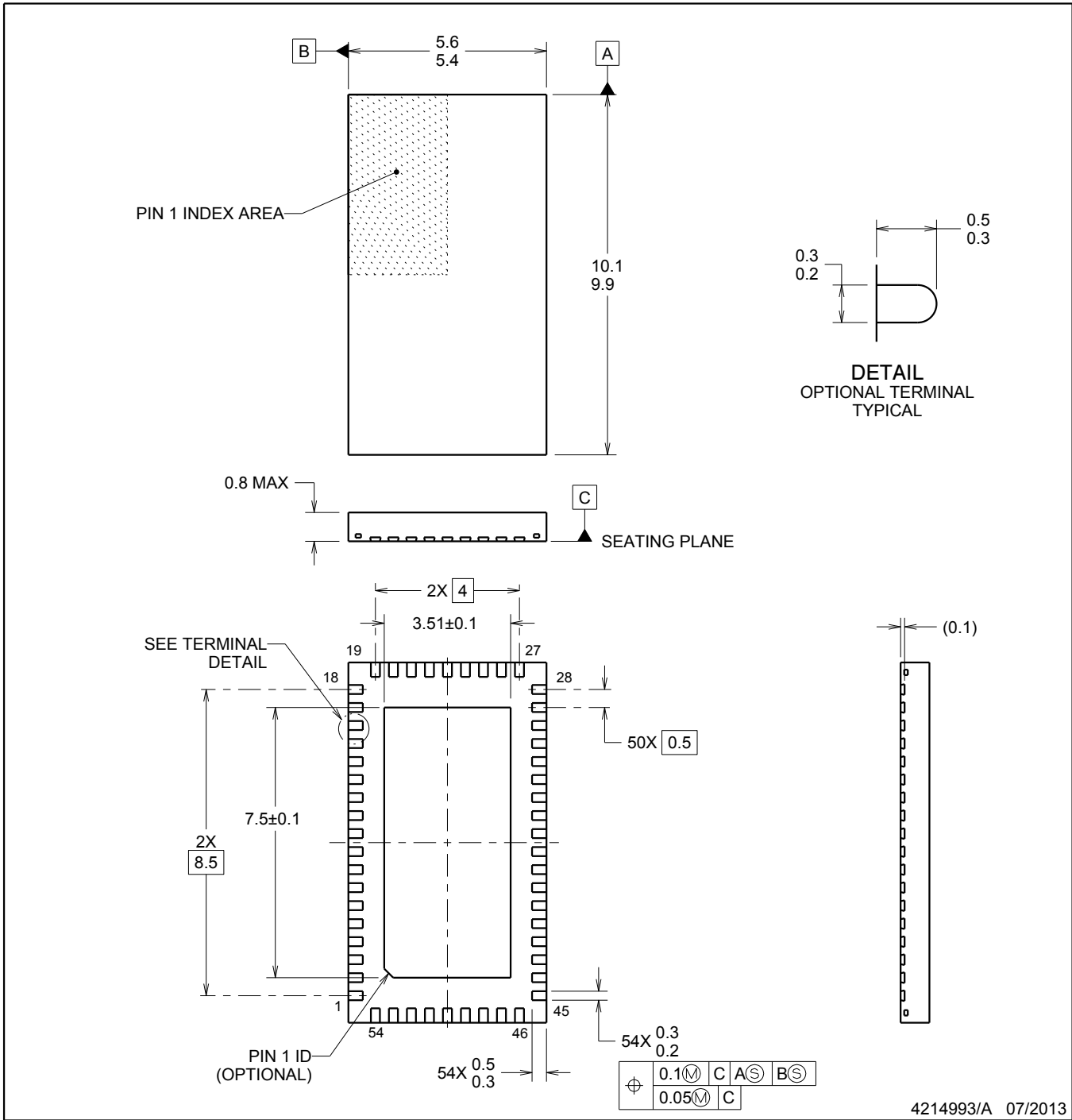

NOTES:

1. All linear dimensions are in millimeters. Dimensions in parenthesis are for reference only. Dimensioning and tolerancing per ASME Y14.5M.
2. This drawing is subject to change without notice.
3. The package thermal pad must be soldered to the printed circuit board for thermal and mechanical performance.

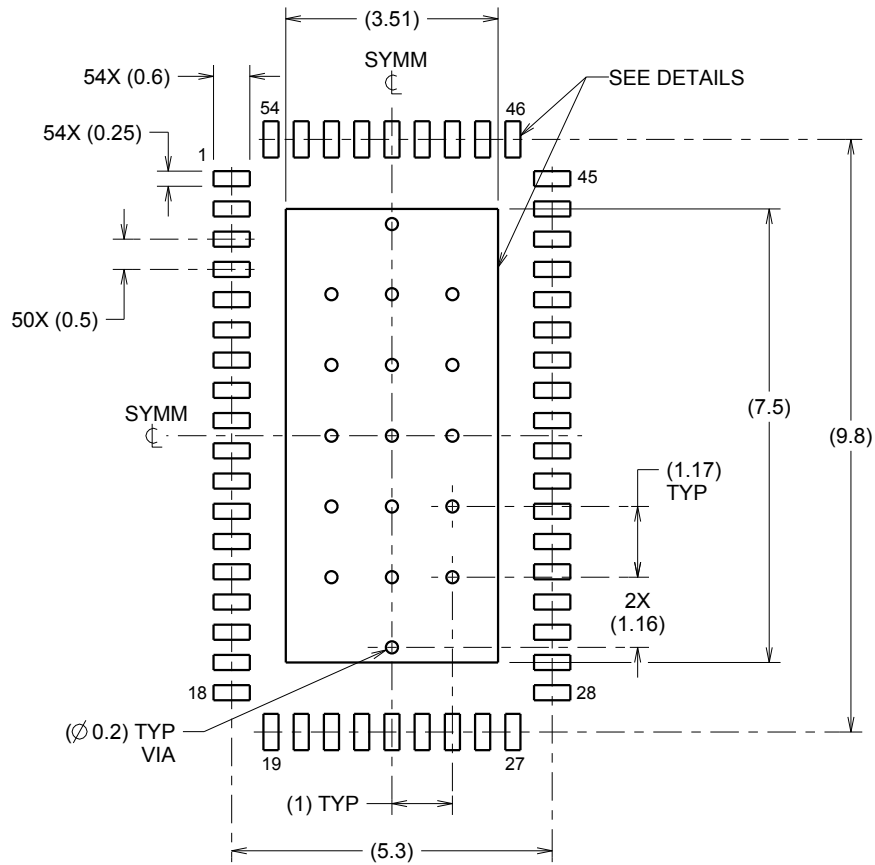

LAND PATTERN EXAMPLE
SCALE:8X

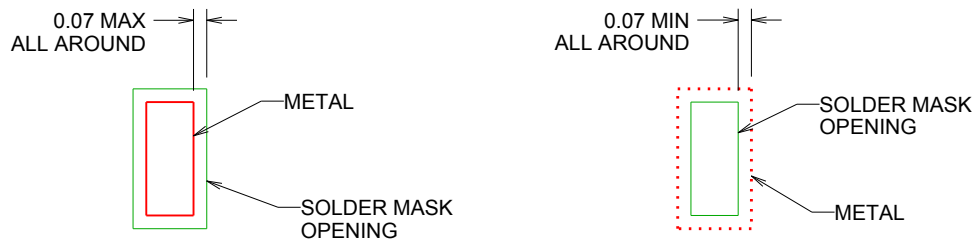

NON SOLDER MASK
DEFINED
(PREFERRED)

SOLDER MASK
DEFINED

SOLDER MASK DETAILS

4214993/A 07/2013

NOTES: (continued)

- This package is designed to be soldered to a thermal pad on the board. For more information, refer to QFN/SON PCB application note in literature No. SLUA271 (www.ti.com/lit/slua271).

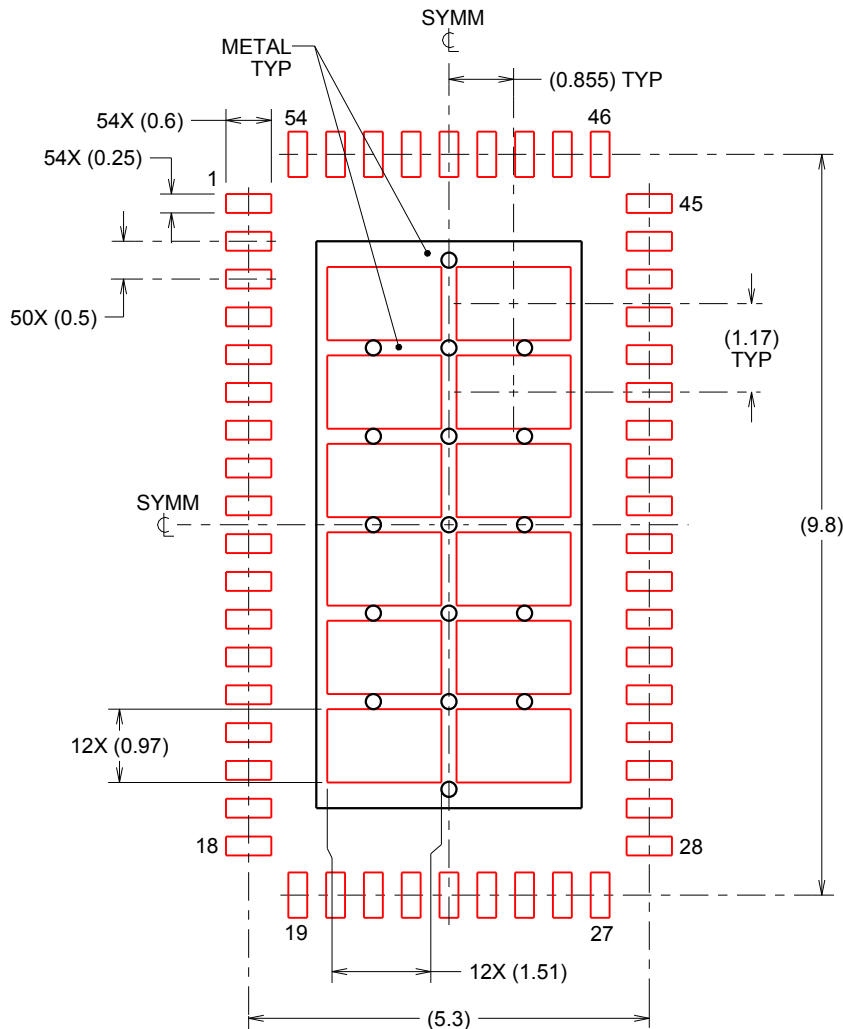

SOLDERPASTE EXAMPLE
 BASED ON 0.125mm THICK STENCIL

EXPOSED PAD
 67% PRINTED SOLDER COVERAGE BY AREA
 SCALE:10X

4214993/A 07/2013

NOTES: (continued)

5. Laser cutting apertures with trapezoidal walls and rounded corners may offer better paste release. IPC-7525 may have alternate design recommendations.

重要声明和免责声明

TI“按原样”提供技术和可靠性数据（包括数据表）、设计资源（包括参考设计）、应用或其他设计建议、网络工具、安全信息和其他资源，不保证没有瑕疵且不做任何明示或暗示的担保，包括但不限于对适销性、某特定用途方面的适用性或不侵犯任何第三方知识产权的暗示担保。

这些资源可供使用 TI 产品进行设计的熟练开发人员使用。您将自行承担以下全部责任：(1) 针对您的应用选择合适的 TI 产品，(2) 设计、验证并测试您的应用，(3) 确保您的应用满足相应标准以及任何其他功能安全、信息安全、监管或其他要求。

这些资源如有变更，恕不另行通知。TI 授权您仅可将这些资源用于研发本资源所述的 TI 产品的应用。严禁对这些资源进行其他复制或展示。您无权使用任何其他 TI 知识产权或任何第三方知识产权。您应全额赔偿因在这些资源的使用中对 TI 及其代表造成的任何索赔、损害、成本、损失和债务，TI 对此概不负责。

TI 提供的产品受 [TI 的销售条款](#) 或 [ti.com](#) 上其他适用条款/TI 产品随附的其他适用条款的约束。TI 提供这些资源并不会扩展或以其他方式更改 TI 针对 TI 产品发布的适用的担保或担保免责声明。

TI 反对并拒绝您可能提出的任何其他或不同的条款。

邮寄地址：Texas Instruments, Post Office Box 655303, Dallas, Texas 75265
Copyright © 2021，德州仪器 (TI) 公司