

## DS26F32MQML Quad Differential Line Receivers

Check for Samples: [DS26F32MQML](#)

### FEATURES

- **Input Voltage Range of  $\pm 7.0V$  (Differential or Common Mode)  $\pm 0.2V$  Sensitivity over the Input Voltage Range**
- **High Input Impedance**
- **Operation from Single +5.0V Supply**
- **Input Pull-Down Resistor Prevents Output Oscillation on Unused Channels**
- **TRI-STATE Outputs, with Choice of Complementary Enables, for Receiving Directly onto a Data Bus**

### DESCRIPTION

The DS26F32 is a quad differential line receiver designed to meet the requirements of EIA Standards RS-422 and RS-423, and Federal Standards 1020 and 1030 for balanced and unbalanced digital data transmission.

The DS26F32 offers improved performance due to the use of state-of-the-art L-FAST bipolar technology. The L-FAST technology allows for higher speeds and lower currents by utilizing extremely short gate delay times. Thus, the DS26F32 features lower power, extended temperature range, and improved specifications.

The device features an input sensitivity of 200 mV over the input common mode range of  $\pm 7.0V$ . The DS26F32 provides an enable function common to all four receivers and TRI-STATE outputs with 8.0 mA sink capability. Also, a fail-safe input/output relationship keeps the outputs high when the inputs are open.

The DS26F32 offers optimum performance when used with the DS26F31 Quad Differential Line Driver.



Please be aware that an important notice concerning availability, standard warranty, and use in critical applications of Texas Instruments semiconductor products and disclaimers thereto appears at the end of this data sheet.

All trademarks are the property of their respective owners.

PRODUCTION DATA information is current as of publication date. Products conform to specifications per the terms of the Texas Instruments standard warranty. Production processing does not necessarily include testing of all parameters.

Copyright © 2006–2013, Texas Instruments Incorporated

Connection Diagrams

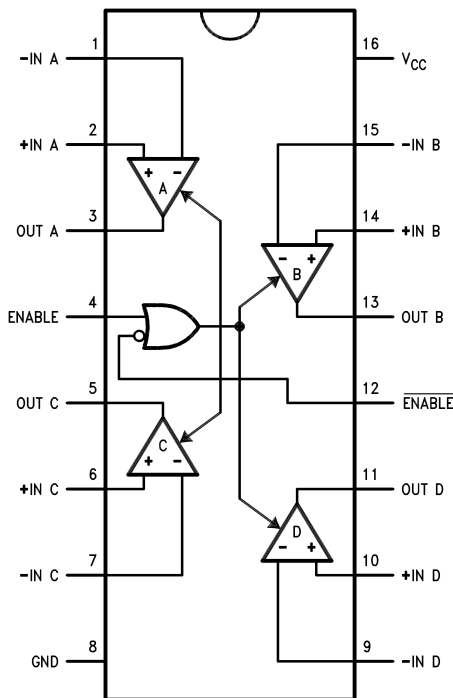

Figure 1. 16-Lead CDIP Package-Top View  
See Package Number NAC0016A, NFE0016A, or NAD0016A

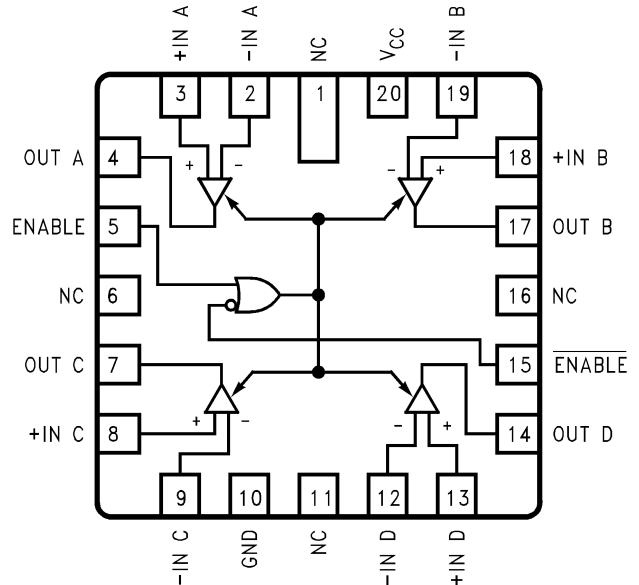

Figure 2. 20-Lead LCCC Package-Top View  
See Package Number NAJ0020A

Table 1. Function Table (Each Receiver)<sup>(1)</sup>

Differential Inputs	Enables		Outputs
$V_{ID} = (V_{I+}) - (V_{I-})$	E	$\bar{E}$	OUT
$V_{ID} \geq 0.2V$	H	X	H
	X	L	H
$V_{ID} \leq -0.2V$	H	X	L
	X	L	L
X	L	H	Z

(1) H = High Level  
L = Low Level  
X = Immaterial



These devices have limited built-in ESD protection. The leads should be shorted together or the device placed in conductive foam during storage or handling to prevent electrostatic damage to the MOS gates.

**Absolute Maximum Ratings <sup>(1)</sup>**

Storage Temperature Range	$-65^{\circ}\text{C} \leq T_A \leq +150^{\circ}\text{C}$
Operating Temperature Range	$-55^{\circ}\text{C} \leq T_A \leq +125^{\circ}\text{C}$
Lead Temperature (soldering, 60 sec)	300°C
Supply Voltage	7.0V
Common Mode Voltage Range	$\pm 25\text{V}$
Differential Input Voltage	$\pm 25\text{V}$
Enable Voltage	7.0V
Output Sink Current	50 mA
Maximum Power Dissipation ( $P_{D\text{ max}}$ at 25°C) <sup>(2), (3)</sup>	500 mW
Thermal Resistance	
$\theta_{JA}$	
NFE0016A package	100°C/W
NAD0016A package	142°C/W
NAJ0020A package	87°C/W
$\theta_{JC}$	
Junction-to- case	See MIL-STD-1835

- (1) Absolute Maximum Ratings indicate limits beyond which damage to the device may occur. Operating Ratings indicate conditions for which the device is functional, but do not verify specific performance limits. For verified specifications and test conditions, see the Electrical Characteristics. The verified specifications apply only for the test conditions listed. Some performance characteristics may degrade when the device is not operated under the listed test conditions.
- (2) Derate J package 10.0mW/°C above +25°C, derate W package 7.1mW/°C above +25°C, derate E package 11.5mW/°C above +25°C.
- (3) Power dissipation must be externally controlled at elevated temperatures.

**Recommended Operating Range**

Operating Temperature	$-55^{\circ}\text{C} \leq T_A \leq +125^{\circ}\text{C}$
Supply Voltage	4.5V to 5.5V

**Table 2. Radiation Features**

DS26F32MJRQMLV	100 krad(Si)
DS26F32MWRQMLV	100 krad(Si)
DS26F32MWGRQMLV	100 krad(Si)

**Table 3. Quality Conformance Inspection Mil-Std-883, Method 5005 - Group A**

Subgroup	Description	Temp °C
1	Static tests at	25
2	Static tests at	125
3	Static tests at	-55
4	Dynamic tests at	25
5	Dynamic tests at	125
6	Dynamic tests at	-55
7	Functional tests at	25
8A	Functional tests at	125
8B	Functional tests at	-55
9	Switching tests at	25
10	Switching tests at	125
11	Switching tests at	-55
12	Settling time at	25
13	Settling time at	125
14	Settling time at	-55

## DS26F32 Electrical Characteristics DC Parameters

The following conditions apply, unless otherwise specified.

DC:  $V_{CC} = 5V$  <sup>(1)</sup>

Parameter		Test Conditions	Notes	Min	Max	Units	Sub-groups
$I_{in}$	Input Current	Pin under test $V_{CC} = 4.5V$ , $V_I = 15V$ Other inputs $-15V \leq V_I \leq +15V$			2.3	mA	1, 2, 3
		Pin under test $V_{CC} = 5.5V$ , $V_I = -15V$ Other inputs $-15V \leq V_I \leq +15V$			-2.8	mA	1, 2, 3
$I_{IL}$	Logical "0" Enable Current	$V_{CC} = 5.5V$ , $V_{En} = 0.4V$			-360	$\mu A$	1, 2, 3
$I_{IH}$	Logical "1" Enable Current	$V_{CC} = 5.5V$ , $V_I = 2.7V$			10	$\mu A$	1, 2, 3
$I_I$	Logical "1" Enable Current	$V_{CC} = 5.5V$ , $V_I = 5.5V$			50	$\mu A$	1, 2, 3
$V_{IK}$	Input Clamp Voltage (Enable)	$V_{CC} = 4.5V$ , $I_I = -18mA$			-1.5	V	1, 2, 3
$V_{OH}$	Logical "1" Output Voltage	$V_{CC} = 4.5V$ , $I_{OH} = -440\mu A$ , $\Delta V_I = 1V$ , $\overline{V_{En}} = .8 = V_{En}$		2.5		V	1, 2, 3
$V_{OL}$	Logical "0" Output Voltage	$V_{CC} = 4.5V$ , $\overline{V_{En}} = 0.8V = V_{En}$ , $I_{OL} = 4mA$ , $\Delta V_I = -1V$			0.4	V	1, 2, 3
		$V_{CC} = 4.5V$ , $\overline{V_{En}} = 8V = V_{En}$ , $I_{OL} = 8mA$ , $\Delta V_I = -1V$			.45	V	1, 2, 3
$I_{CC}$	Supply Current	$V_{CC} = 5.5V$ , All $V_I = Gnd$ , $V_{En} = 0V$ , $\overline{V_{En}} = 2V$			50	mA	1, 2, 3
$I_{OZ}$	Off-State Output Current	$V_{CC} = 5.5V$ , $V_O = 0.4V$ , $V_{En} = 0.8V$ , $\overline{V_{En}} = 2V$			-20	$\mu A$	1, 2, 3
		$V_{CC} = 5.5V$ , $V_O = 2.4V$ , $V_{En} = 0.8V$ , $\overline{V_{En}} = 2V$			20	$\mu A$	1, 2, 3
$R_I$	Input Resistance	$-15 \leq V_{CM} \leq 15V$		14		K $\Omega$	1, 2, 3
$V_{Th}$	Differential Input Voltage	$V_{CC} = 4.5V$ , $V_{OUT} = V_{OL}$ or $V_{OH}$ $-7V \leq V_{CM} \leq 7V$ , $V_{En} = \overline{V_{En}} = 2.5V$	(2)	-0.2	0.2	V	1, 2, 3
		$V_{CC} = 5.5V$ , $V_{OUT} = V_{OL}$ or $V_{OH}$ $-7V \leq V_{CM} \leq 7V$ , $V_{En} = \overline{V_{En}} = 2.5V$	(2)	-0.2	0.2	V	1, 2, 3
$V_{IL}$	Logical "0" Input Voltage (Enable)	$V_{CC} = 5.5V$	(2)		0.8	V	1, 2, 3
$V_{IH}$	Logical "1" Input Voltage (Enable)	$V_{CC} = 4.5V$	(2)	2.0		V	1, 2, 3
$I_{SC Min}$	Output Short Circuit Current	$V_{CC} = 4.5V$ , $V_O = 0V$ , $\Delta V_I = 1V$		-15		mA	1, 2, 3
$I_{SC Max}$	Output Short Circuit Current	$V_{CC} = 5.5V$ , $V_O = 0V$ , $\Delta V_I = 1V$			-85	mA	1, 2, 3

(1) Pre and post irradiation limits are identical to those listed under AC and DC electrical characteristics. These parts may be dose rate sensitive in a space environment and demonstrate enhanced low dose rate effect. Radiation end point limits for the noted parameters are specified only for the conditions as specified in Mil-Std-883, Method 1019.5, Condition A

(2) Parameter tested go-no-go only.

## DS26F32 Electrical Characteristics AC Parameters

The following conditions apply, unless otherwise specified.

AC:  $V_{CC} = 5V$  <sup>(1)</sup>

Parameter		Test Conditions	Notes	Min	Max	Units	Sub-groups
t <sub>PLH</sub>		C <sub>L</sub> = 50pF	(2)		23	nS	9
			(2)		31	nS	10, 11
		C <sub>L</sub> = 15pF	(3)		22	nS	9
			(3)		30	nS	10, 11
t <sub>PHL</sub>		C <sub>L</sub> = 50pF	(2)		23	nS	9
			(2)		31	nS	10, 11
		C <sub>L</sub> = 15pF	(3)		22	nS	9
			(3)		30	nS	10, 11
t <sub>PZH</sub>	Enable Time	C <sub>L</sub> = 50pF	(2)		18	nS	9
			(2)		29	nS	10, 11
		C <sub>L</sub> = 15pF	(3)		16	nS	9
			(3)		27	nS	10, 11
t <sub>PZL</sub>	Enable Time	C <sub>L</sub> = 50pF	(2)		20	nS	9
			(2)		29	nS	10, 11
		C <sub>L</sub> = 15pF	(3)		18	nS	9
			(3)		27	nS	10, 11
t <sub>PHZ</sub>	Disable Time	C <sub>L</sub> = 50pF	(2)		55	nS	9
			(2)		62	nS	10, 11
		C <sub>L</sub> = 5pF	(3)		20	nS	9
			(3)		27	nS	10, 11
t <sub>PLZ</sub>	Disable Time	C <sub>L</sub> = 50pF	(2)		30	nS	9
			(2)		42	nS	10, 11
		C <sub>L</sub> = 5pF	(3)		18	nS	9
			(3)		30	nS	10, 11

- (1) Pre and post irradiation limits are identical to those listed under AC and DC electrical characteristics. These parts may be dose rate sensitive in a space environment and demonstrate enhanced low dose rate effect. Radiation end point limits for the noted parameters are specified only for the conditions as specified in Mil-Std-883, Method 1019.5, Condition A
- (2) Tested at 50pF, system capacitance exceeds 5pF to 15pF.
- (3) Tested at 50pF specifies limit at 15pF & 5pF.

## DS26F32 Electrical Characteristics DC Drift Parameters

This section applies to -QMLV devices only. Devices shall be read & recorded at T<sub>A</sub> = 25°C before and after each burn-in and shall not change by more than the limits indicated. The delta rejects shall be included in the PDA calculation.

Parameter		Test Conditions	Notes	Min	Max	Units	Sub-groups
V <sub>OH</sub>	Logical "1" Output Voltage	V <sub>CC</sub> = 4.5V, I <sub>OH</sub> = -440μA, ΔV <sub>I</sub> = 1V, V <sub>En</sub> = 0.8V = V <sub>En</sub>		-250	250	mV	1
V <sub>OL</sub>	Logical "0" Output Voltage	V <sub>CC</sub> = 4.5V, I <sub>OL</sub> = 4mA, ΔV <sub>I</sub> = -1V, V <sub>En</sub> = 0.8V = V <sub>En</sub>		-45	45	mV	1
		V <sub>CC</sub> = 4.5V, I <sub>OL</sub> = 8mA, ΔV <sub>I</sub> = -1V, V <sub>En</sub> = 0.8V = V <sub>En</sub>		-45	45	mV	1
I <sub>I</sub>	Input Current	Pin under test V <sub>CC</sub> = 4.5V, V <sub>I</sub> = 15V Other inputs -15V ≤ V <sub>I</sub> ≤ +15V		-0.28	0.28	mA	1
		Pin under test V <sub>CC</sub> = 5.5V, V <sub>I</sub> = -15V Other inputs -15V ≤ V <sub>I</sub> ≤ +15V		-0.28	0.28	mA	1

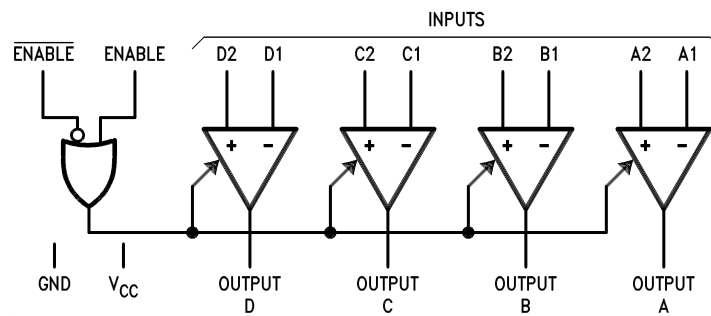
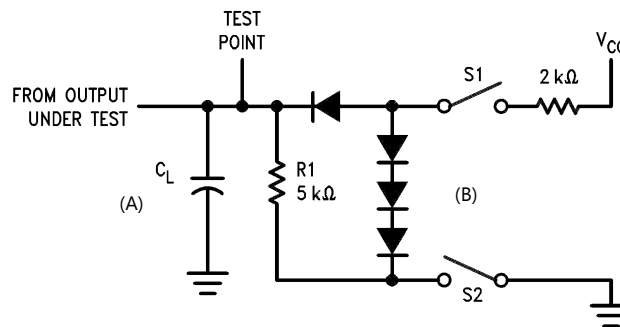

Figure 3. Logic Symbol



$C_L$  includes probe and jig capacitance.

- A. Parameter tested go-no-go only.
- B. Tested at 50pF specifies limit at 15pF and 5pF.

Figure 4. Load Test Circuit for Three-State Outputs

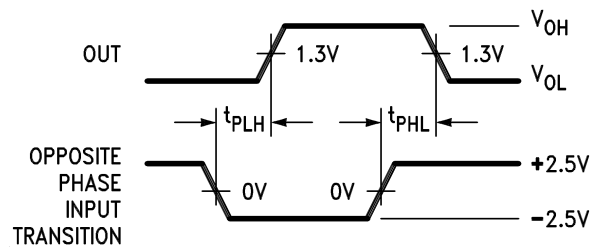

Diagram shown for  $\overline{\text{ENABLE}}$  Low.

S1 and S2 of Load Circuit are closed except where shown.

Pulse Generator of all Pulses: Rate  $\leq$  1.0 MHz,  $Z_O = 50\Omega$ ,  $t_r \leq 6.0$  ns,  $t_f \leq 6.0$  ns.

Figure 5. Propagation Delay

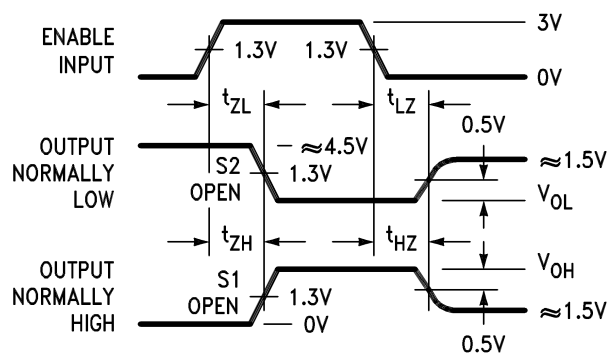

Diagram shown for  $\overline{\text{ENABLE}}$  Low.

S1 and S2 of Load Circuit are closed except where shown.

Pulse Generator of all Pulses: Rate  $\leq$  1.0 MHz,  $Z_O = 50\Omega$ ,  $t_r \leq 6.0$  ns,  $t_f \leq 6.0$  ns.

All diodes are IN916 or IN3064.

Figure 6. Enable and Disable Times

TYPICAL APPLICATION

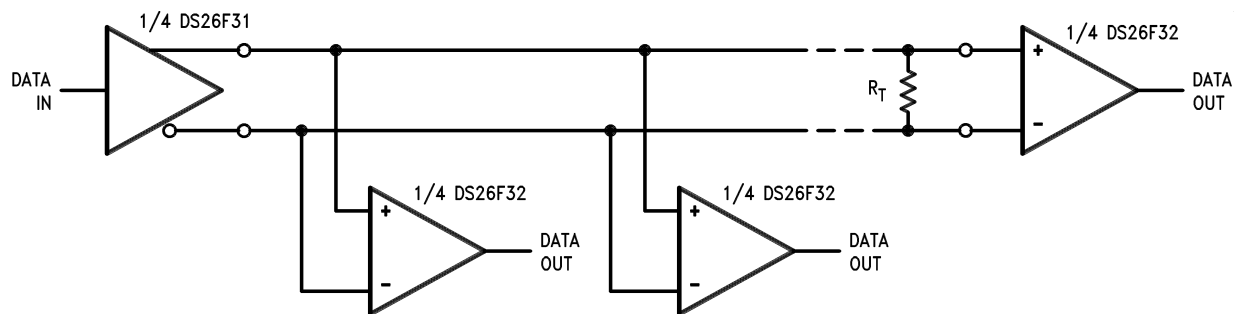

**REVISION HISTORY**

Released	Revision	Section	Originator	Changes
3/01/06	*	New Release, Corporate format	L. Lytle	1 MDS data sheet converted into one Corp. data sheet format. MNDS26F32M-X-RH Rev 0C0 will be archived.
4/15/2013	A		TIS	Changed layout of National Data Sheet to TI format

**PACKAGING INFORMATION**

Orderable Device	Status (1)	Package Type	Package Drawing	Pins	Package Qty	Eco Plan (2)	Lead finish/ Ball material (6)	MSL Peak Temp (3)	Op Temp (°C)	Device Marking (4/5)	Samples
5962-7802005M2A	ACTIVE	LCCC	NAJ	20	50	RoHS-Exempt & Green	Call TI	Level-1-NA-UNLIM	-55 to 125	DS26F32ME/ 883 Q 5962-78020 05M2A ACO 05M2A >T	<a href="#">Samples</a>
5962-7802005MFA	ACTIVE	CFP	NAD	16	19	Non-RoHS & Green	Call TI	Level-1-NA-UNLIM	-55 to 125	DS26F32MW /883 Q 5962-78020 05MFA ACO 05MFA >T	<a href="#">Samples</a>
5962R7802005VEA	ACTIVE	CDIP	NFE	16	25	Non-RoHS & Green	Call TI	Level-1-NA-UNLIM	-55 to 125	DS26F32MJRQMLV 5962R7802005VEA Q	<a href="#">Samples</a>
5962R7802005VFA	ACTIVE	CFP	NAD	16	19	Non-RoHS & Green	Call TI	Level-1-NA-UNLIM	-55 to 125	DS26F32MWR QMLV Q 5962R78020 05VFA ACO 05VFA >T	<a href="#">Samples</a>
DS26F32 MW8	ACTIVE	WAFERSALE	YS	0	1	RoHS & Green	Call TI	Level-1-NA-UNLIM	-55 to 125		<a href="#">Samples</a>
DS26F32ME/883	ACTIVE	LCCC	NAJ	20	50	RoHS-Exempt & Green	Call TI	Level-1-NA-UNLIM	-55 to 125	DS26F32ME/ 883 Q 5962-78020 05M2A ACO 05M2A >T	<a href="#">Samples</a>
DS26F32MJRQMLV	ACTIVE	CDIP	NFE	16	25	Non-RoHS & Green	Call TI	Level-1-NA-UNLIM	-55 to 125	DS26F32MJRQMLV 5962R7802005VEA Q	<a href="#">Samples</a>
DS26F32MW/883	ACTIVE	CFP	NAD	16	19	Non-RoHS & Green	Call TI	Level-1-NA-UNLIM	-55 to 125	DS26F32MW /883 Q 5962-78020 05MFA ACO 05MFA >T	<a href="#">Samples</a>
DS26F32MWRQMLV	ACTIVE	CFP	NAD	16	19	Non-RoHS & Green	Call TI	Level-1-NA-UNLIM	-55 to 125	DS26F32MWR QMLV Q 5962R78020 05VFA ACO 05VFA >T	<a href="#">Samples</a>

(1) The marketing status values are defined as follows:

**ACTIVE:** Product device recommended for new designs.

**LIFEBUY:** TI has announced that the device will be discontinued, and a lifetime-buy period is in effect.

**NRND:** Not recommended for new designs. Device is in production to support existing customers, but TI does not recommend using this part in a new design.

**PREVIEW:** Device has been announced but is not in production. Samples may or may not be available.

**OBSOLETE:** TI has discontinued the production of the device.

(2) **RoHS:** TI defines "RoHS" to mean semiconductor products that are compliant with the current EU RoHS requirements for all 10 RoHS substances, including the requirement that RoHS substance do not exceed 0.1% by weight in homogeneous materials. Where designed to be soldered at high temperatures, "RoHS" products are suitable for use in specified lead-free processes. TI may reference these types of products as "Pb-Free".

**RoHS Exempt:** TI defines "RoHS Exempt" to mean products that contain lead but are compliant with EU RoHS pursuant to a specific EU RoHS exemption.

**Green:** TI defines "Green" to mean the content of Chlorine (Cl) and Bromine (Br) based flame retardants meet JS709B low halogen requirements of  $\leq 1000$ ppm threshold. Antimony trioxide based flame retardants must also meet the  $\leq 1000$ ppm threshold requirement.

(3) MSL, Peak Temp. - The Moisture Sensitivity Level rating according to the JEDEC industry standard classifications, and peak solder temperature.

(4) There may be additional marking, which relates to the logo, the lot trace code information, or the environmental category on the device.

(5) Multiple Device Markings will be inside parentheses. Only one Device Marking contained in parentheses and separated by a "~" will appear on a device. If a line is indented then it is a continuation of the previous line and the two combined represent the entire Device Marking for that device.

(6) Lead finish/Ball material - Orderable Devices may have multiple material finish options. Finish options are separated by a vertical ruled line. Lead finish/Ball material values may wrap to two lines if the finish value exceeds the maximum column width.

**Important Information and Disclaimer:**The information provided on this page represents TI's knowledge and belief as of the date that it is provided. TI bases its knowledge and belief on information provided by third parties, and makes no representation or warranty as to the accuracy of such information. Efforts are underway to better integrate information from third parties. TI has taken and continues to take reasonable steps to provide representative and accurate information but may not have conducted destructive testing or chemical analysis on incoming materials and chemicals. TI and TI suppliers consider certain information to be proprietary, and thus CAS numbers and other limited information may not be available for release.

In no event shall TI's liability arising out of such information exceed the total purchase price of the TI part(s) at issue in this document sold by TI to Customer on an annual basis.

**OTHER QUALIFIED VERSIONS OF DS26F32MQML, DS26F32MQML-SP :**

- Military : [DS26F32MQML](#)
- Space : [DS26F32MQML-SP](#)

NOTE: Qualified Version Definitions:

- Military - QML certified for Military and Defense Applications
- Space - Radiation tolerant, ceramic packaging and qualified for use in Space-based application

**TUBE**

\*All dimensions are nominal

Device	Package Name	Package Type	Pins	SPQ	L (mm)	W (mm)	T (μm)	B (mm)
5962-7802005M2A	NAJ	LCCC	20	50	470	11	3810	0
5962-7802005MFA	NAD	CFP	16	19	502	23	9398	9.78
5962R7802005VEA	NFE	CDIP	16	25	502	14	10668	4.32
5962R7802005VFA	NAD	CFP	16	19	502	23	9398	9.78
DS26F32ME/883	NAJ	LCCC	20	50	470	11	3810	0
DS26F32MJRQMLV	NFE	CDIP	16	25	502	14	10668	4.32
DS26F32MW/883	NAD	CFP	16	19	502	23	9398	9.78
DS26F32MWRQMLV	NAD	CFP	16	19	502	23	9398	9.78



NFE0016A

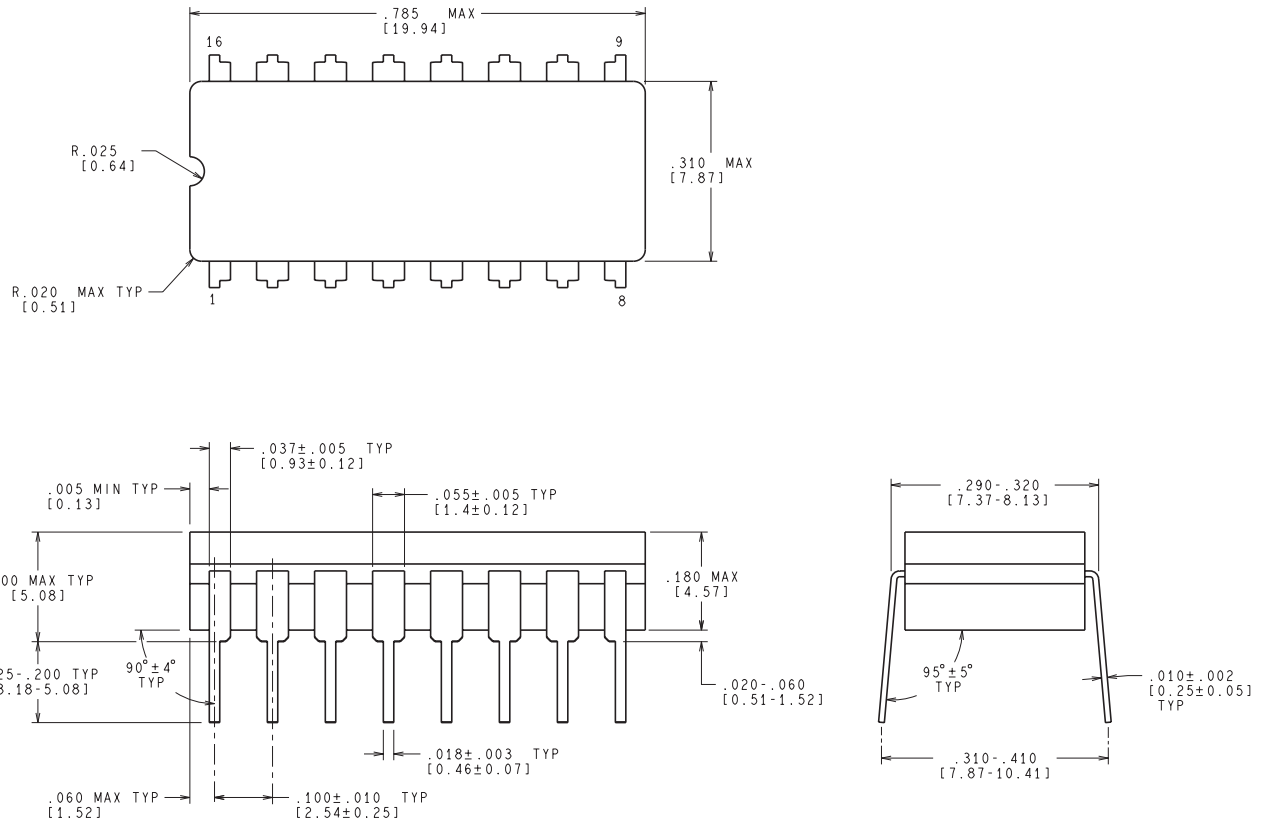

CONTROLLING DIMENSION IS INCH  
VALUES IN [ ] ARE MILLIMETERS

J16A (REV L)

NAD0016A

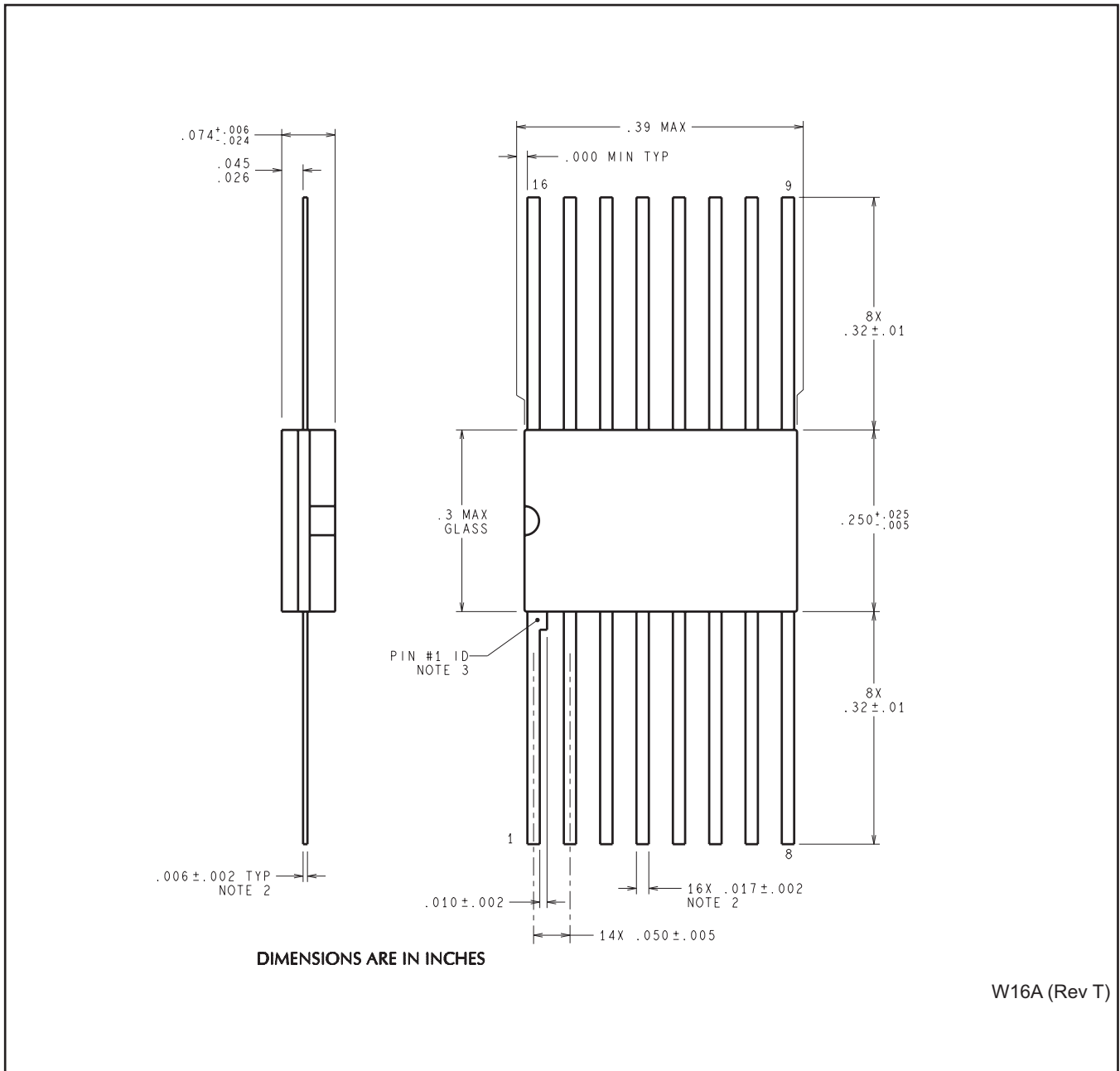

## IMPORTANT NOTICE AND DISCLAIMER

TI PROVIDES TECHNICAL AND RELIABILITY DATA (INCLUDING DATA SHEETS), DESIGN RESOURCES (INCLUDING REFERENCE DESIGNS), APPLICATION OR OTHER DESIGN ADVICE, WEB TOOLS, SAFETY INFORMATION, AND OTHER RESOURCES "AS IS" AND WITH ALL FAULTS, AND DISCLAIMS ALL WARRANTIES, EXPRESS AND IMPLIED, INCLUDING WITHOUT LIMITATION ANY IMPLIED WARRANTIES OF MERCHANTABILITY, FITNESS FOR A PARTICULAR PURPOSE OR NON-INFRINGEMENT OF THIRD PARTY INTELLECTUAL PROPERTY RIGHTS.

These resources are intended for skilled developers designing with TI products. You are solely responsible for (1) selecting the appropriate TI products for your application, (2) designing, validating and testing your application, and (3) ensuring your application meets applicable standards, and any other safety, security, regulatory or other requirements.

These resources are subject to change without notice. TI grants you permission to use these resources only for development of an application that uses the TI products described in the resource. Other reproduction and display of these resources is prohibited. No license is granted to any other TI intellectual property right or to any third party intellectual property right. TI disclaims responsibility for, and you will fully indemnify TI and its representatives against, any claims, damages, costs, losses, and liabilities arising out of your use of these resources.

TI's products are provided subject to [TI's Terms of Sale](#) or other applicable terms available either on [ti.com](http://ti.com) or provided in conjunction with such TI products. TI's provision of these resources does not expand or otherwise alter TI's applicable warranties or warranty disclaimers for TI products.

TI objects to and rejects any additional or different terms you may have proposed.

Mailing Address: Texas Instruments, Post Office Box 655303, Dallas, Texas 75265  
Copyright © 2022, Texas Instruments Incorporated