

DS100MB203 10.3125 Gbps Dual Lane 2:1/1:2 Mux/Buffer With Equalization and De-Emphasis

1 Features

- 10.3125 Gbps Dual Lane 2:1 Mux, 1:2 Switch or Fan-Out
- Low 390 mW Total Power (Typical)
- Advanced Signal Conditioning Features:
 - Receive Equalization Up to 36 dB at 5 GHz
 - Transmit De-Emphasis Up to –12 dB
 - Transmit Output Voltage Control: 600 mV to 1300 mV
- Programmable Through Pin Selection, EEPROM or SMBus Interface
- Selectable 2.5-V or 3.3-V Supply Voltage
- –40°C to 85°C Operating Temperature Range

2 Applications

- 10GE, 10G-KR
- PCIe Gen-1/2/3
- SAS2/SATA3 (Up to 6 Gbps)
- XAUI, RXAUI

3 Description

The DS100MB203 device is a dual port 2:1 multiplexer and 1:2 switch or fan-out buffer with signal conditioning suitable for 10GE, 10G-KR (802.3ap), Fibre Channel, PCIe, Infiniband, SATA3/SAS2 and other high-speed bus applications with data rates up to 10.3125 Gbps.

The continuous time linear equalizer (CTLE) of the receiver provides necessary boost to compensate up to 40" FR-4 or 10m cable (AWG-24) at 10.3125 Gbps - This on-chip feature eliminates the need for external signal conditioners. The transmitter features a programmable amplitude voltage levels to be selectable from 600 mVp-p to 1300 mVp-p and De-Emphasis of up to 12 dB.

The DS100MB203 can be configured to support PCIe, SAS/SATA, 10G-KR or other signaling protocols. When operating in 10G-KR and PCIe Gen-3 mode, the DS100MB203 transparently allows the host controller and the end point to optimize the full link and negotiate transmit equalizer coefficients. This seamless management of the link training protocol ensures system level interoperability with minimum latency.

The programmable settings can be applied through pin settings, SMBus (I²C) protocol or loaded directly from an external EEPROM. When operating in the EEPROM mode, the configuration information is automatically loaded on power up, which eliminates the need for an external microprocessor or software driver.

Device Information⁽¹⁾

PART NUMBER	PACKAGE	BODY SIZE (NOM)
DS100MB203	WQFN (54)	10.00 mm x 5.50 mm

(1) For all available packages, see the orderable addendum at the end of the data sheet.

Simplified Functional Block Diagram

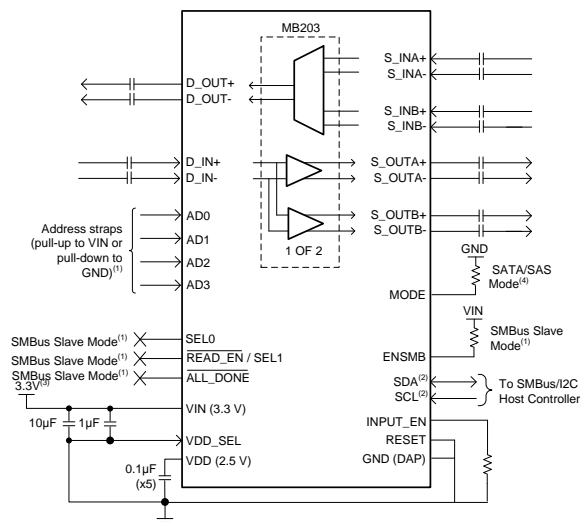

- (1) Schematic shows connection for SMBus Slave Mode (ENSMB = 1 kΩ to VIN). For SMBus Master Mode or Pin Mode configuration, the connections are different.
- (2) SMBus signals must be pulled up elsewhere in the system.
- (3) Schematic requires different connections for 2.5 V mode.
- (4) Schematic requires pullup resistor for 10G-KR Mode.

Typical Application

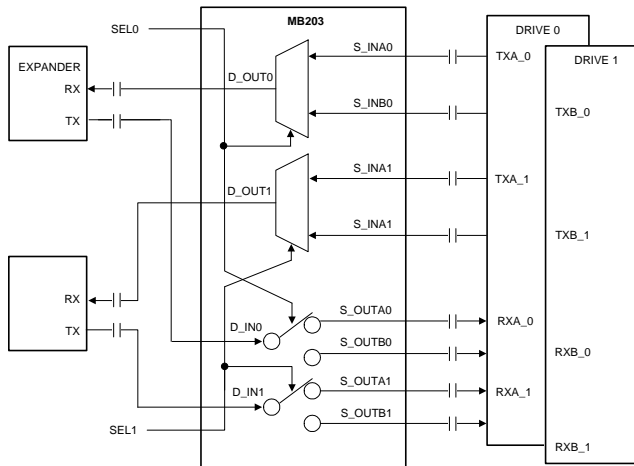

5 Pin Configuration and Functions

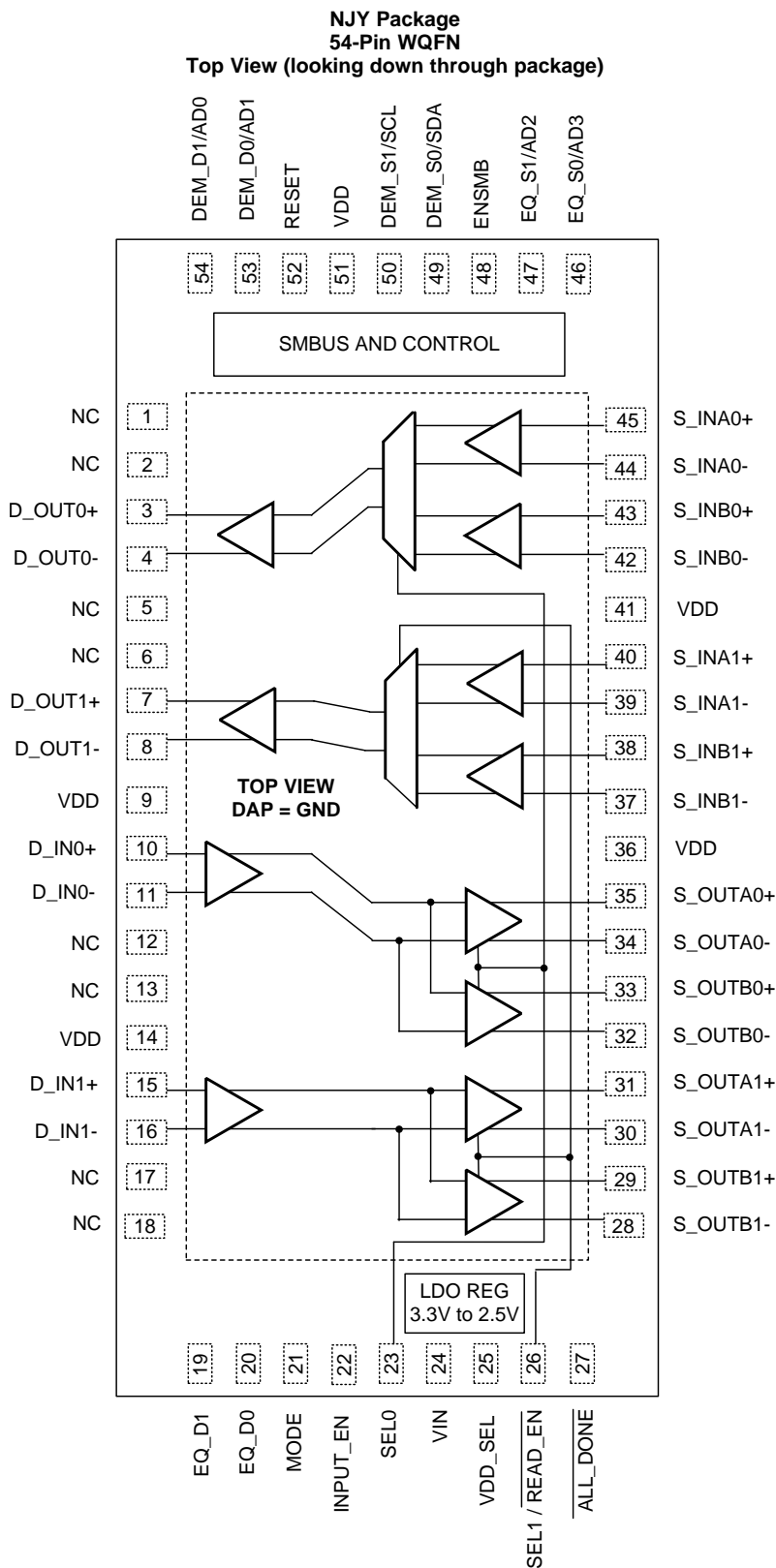

Pin Functions: Common Connections⁽¹⁾

PIN		TYPE	DESCRIPTION
NAME	NO.		
DIFFERENTIAL HIGH-SPEED INPUTS AND OUTPUTS			
D_IN0+, D_IN0-, D_IN1+, D_IN1-	10, 11, 15, 16	I	Inverting and noninverting CML differential inputs to the equalizer. A gated on-chip 50-Ω termination resistor connects D_INn+ to VDD and D_INn- to VDD when enabled. AC coupling required on high-speed I/O.
D_OUT0+, D_OUT0-, D_OUT1+, D_OUT1-	3, 4, 7, 8	O	Inverting and noninverting low power differential signaling 50-Ω outputs with de-emphasis. Fully compatible with AC-coupled CML inputs. AC coupling required on high-speed I/O.
S_INA0+, S_INA0-, S_INA1+, S_INA1-	45, 44, 40, 39	I	Inverting and noninverting CML differential inputs to the equalizer. An on-chip 50-Ω termination resistor connects S_INAn+ to VDD and S_INAn- to VDD. AC coupling required on high-speed I/O.
S_INB0+, S_INB0-, S_INB1+, S_INB1-	43, 42, 38, 37	I	Inverting and noninverting CML differential inputs to the equalizer. An on-chip 50-Ω termination resistor connects S_INBn+ to VDD and S_INBn- to VDD. AC coupling required on high-speed I/O.
S_OUTA0+, S_OUTA0-, S_OUTA1+, S_OUTA1-	35, 34, 31, 30	O	Inverting and noninverting low power differential signaling 50-Ω outputs with de-emphasis. Fully compatible with AC-coupled CML inputs.
S_OUTB0+, S_OUTB0-, S_OUTB1+, S_OUTB1-	33, 32, 29, 28	O	Inverting and noninverting low power differential signaling 50-Ω outputs with de-emphasis. Fully compatible with AC-coupled CML inputs. AC coupling required on high-speed I/O.
CONTROL PINS - SHARED (LVCMOS)			
ENSMB	48	I, FLOAT, LVCMOS	System Management Bus (SMBus) enable pin Tie 1 kΩ to VDD = register access SMBus slave mode FLOAT = read external EEPROM (master SMBUS mode) Tie 1 kΩ to GND = Pin Mode
CONTROL PINS—BOTH PIN AND SMBUS MODES (LVCMOS)			
RESET	52	I, LVCMOS	0: Normal operation (device is enabled). 1: low power mode.
VDD_SEL	25	I, FLOAT	Controls the internal regulator FLOAT: 2.5-V mode Tied to GND: 3.3-V mode
POWER			
GND	DAP	Power	Ground pad (DAP - die attach pad).
VDD	9, 14, 36, 41, 51	Power	Power supply pins CML/analog 2.5-V mode, connect to 2.5 V ±5% 3.3-V mode, connect 0.1-μF cap to each VDD pin
VIN	24	Power	In 3.3-V mode, feed 3.3 V ±10% to VIN In 2.5-V mode, leave floating.

- (1) LVCMOS inputs without the "Float" conditions must be driven to a logic low or high at all times or operation is not ensured. Input edge rate for LVCMOS/FLOAT inputs must be faster than 50 ns from 10–90%. For 3.3-V mode operation, VIN pin = 3.3 V and the "VDD" for the 4-level input is 3.3 V. For 2.5-V mode operation, VDD pin = 2.5 V and the "VDD" for the 4-level input is 2.5 V.

Pin Functions: SMBus/EEPROM Control

PIN		TYPE	DESCRIPTION
NAME	NO.		
ENSMB = 1 (SMBUS SLAVE MODE), FLOAT (SMBUS MASTER MODE)			
AD0-AD3	54, 53, 47, 46	I, LVCMOS	ENSMB master or slave mode SMBus slave address Inputs. In SMBus mode, these pins are the user set SMBus slave address inputs.
$\overline{\text{READ_EN}}$	26	I, LVCMOS	ENSMB = FLOAT (SMBUS master mode) When using an external EEPROM, a transition from high to low starts the load from the external EEPROM
SCL	50	I, LVCMOS, O, Open-drain	ENSMB master or slave mode SMBUS clock input pin is enabled (slave mode) SMBUS clock output when loading configuration from EEPROM (master mode)
SDA	49	I, LVCMOS, O, Open-drain	ENSMB Master or Slave mode The SMBus bidirectional SDA pin is enabled. Data input or open drain (pulldown only) output.
CONTROL PINS—BOTH PIN AND SMBUS MODES (LVCMOS)			
INPUT_EN	22	I, 4-LEVEL, LVCMOS	0: Normal operation, FANOUT is disabled, use SEL0/1 to select the A or B input/output (see SEL0/1 pin), input always enabled with 50 Ω . 20k Ω to GND: Reserved FLOAT: AUTO - Use RX Detect, SEL0/1 to determine which input or output to enable, FANOUT is disable 1: Normal operation, FANOUT is enabled (both S_OUT0/1 are ON). Input always enabled with 50 Ω .
MODE	21	I, 4-LEVEL, LVCMOS	0: SATA/SAS, PCIe GEN 1/2 and 10GE FLOAT: AUTO (PCIe GEN 1/2 or GEN 3) 1: 10-KR
SEL0	23	I, 4-LEVEL, LVCMOS	Select pin for Lane 0. 0: selects input S_INB0\pm , output S_OUTB0\pm . 20 k Ω to GND: selects input S_INB0\pm , output S_OUTA0\pm . FLOAT: selects input S_INA0\pm , output S_OUTB0\pm . 1: selects input S_INA0\pm , output S_OUTA0\pm .
SEL1	26	I, 4-LEVEL, LVCMOS	Select pin for Lane 1. 0: selects input S_INB1\pm , output S_OUTB1\pm . 20 k Ω to GND: selects input S_INB1\pm , output S_OUTA1\pm . FLOAT: selects input S_INA1\pm , output S_OUTB1\pm . 1: selects input S_INA1\pm , output S_OUTA1\pm .
OUTPUT (LVCMOS)			
$\overline{\text{ALL_DONE}}$	27	O, LVCMOS	Valid Register Load Status Output 0: External EEPROM load passed 1: External EEPROM load failed

Pin Functions: Pin Control

PIN		TYPE	DESCRIPTION
NAME	NO.		
ENSMB = 0 (PIN MODE)			
DEM_S0, DEM_S1 DEM_D0, DEM_D1	49, 50, 53, 54	I, 4-LEVEL, LVCMOS	DEM_D[1:0] and DEM_S[1:0] control the level of VOD and de-emphasis on the high-speed output. The outputs are organized into two sides. The D side is controlled with the DEM_D[1:0] pins and the S side is controlled with the DEM_S[1:0] pins. See Table 3 .
EQ_D0, EQ_D1 EQ_S0, EQ_S1	20, 19, 46, 47	I, 4-LEVEL, LVCMOS	EQ_D[1:0] and EQ_S[1:0] control the level of equalization on the high-speed input pins. The inputs are organized into two sides. The D side is controlled with the EQ_D[1:0] pins and the S side is controlled with the EQ_S[1:0] pins. See Table 2 .
CONTROL PINS—BOTH PIN AND SMBus MODES (LVCMOS)			
INPUT_EN	22	I, 4-LEVEL, LVCMOS	0: Normal operation, FANOUT is disabled, use SEL0/1 to select the A or B input/output (see SEL0/1 pin), input always enabled with 50 Ω. 20kΩ to GND: Reserved FLOAT: AUTO - Use RX Detect, SEL0/1 to determine which input or output to enable, FANOUT is disable 1: Normal operation, FANOUT is enabled (both S_OUT0/1 are ON). Input always enabled with 50 Ω.
MODE	21	I, 4-LEVEL, LVCMOS	0: SATA/SAS, PCIe GEN 1/2 and 10GE FLOAT: AUTO (PCIe GEN 1/2 or GEN 3) 1: 10-KR
SEL0	23	I, 4-LEVEL, LVCMOS	Select pin for lane 0. 0: selects input S_INB0± , output S_OUTB0± . 20kΩ to GND: selects input S_INB0± , output S_OUTA0± . FLOAT: selects input S_INA0± , output S_OUTB0± . 1: selects input S_INA0± , output S_OUTA0± .
SEL1	26	I, 4-LEVEL, LVCMOS	Select pin for Lane 1. 0: selects input S_INB1± , output S_OUTB1± . 20kΩ to GND: selects input S_INB1± , output S_OUTA1± . FLOAT: selects input S_INA1± , output S_OUTB1± . 1: selects input S_INA1± , output S_OUTA1± .

6 Specifications

6.1 Absolute Maximum Ratings

See ⁽¹⁾⁽²⁾⁽³⁾.

		MIN	MAX	UNIT
Supply voltage (VDD – 2.5-V mode)		–0.5	2.75	V
Supply voltage (VIN – 3.3-V mode)		–0.5	4	V
LVCMOS input / output voltage		–0.5	4	V
CML input voltage		–0.5	(VDD + 0.5)	V
CML input current		–30	30	mA
Junction temperature			125	°C
Lead temperature	Soldering (4 sec.) ⁽³⁾		260	°C
Storage temperature, T _{stg}		–40	150	°C

- Stresses beyond those listed under *Absolute Maximum Ratings* may cause permanent damage to the device. These are stress ratings only, which do not imply functional operation of the device at these or any other conditions beyond those indicated under *Recommended Operating Conditions*. Exposure to absolute-maximum-rated conditions for extended periods may affect device reliability.
- If Military/Aerospace specified devices are required, please contact the Texas Instruments Sales Office/Distributors for availability and specifications.
- Soldering Information: [SNOA549](#)

6.2 ESD Ratings

		VALUE	UNIT
V _(ESD)	Electrostatic discharge	Human body model (HBM), per ANSI/ESDA/JEDEC JS-001 ⁽¹⁾	±3000
		Charged-device model (CDM), per JEDEC specification JESD22-C101 ⁽²⁾	±1000

- JEDEC document JEP155 states that 500-V HBM allows safe manufacturing with a standard ESD control process.
- JEDEC document JEP157 states that 250-V CDM allows safe manufacturing with a standard ESD control process.

6.3 Recommended Operating Conditions

		MIN	NOM	MAX	UNIT
Supply voltage	2.5-V mode	2.375	2.5	2.625	V
	3.3-V mode	3	3.3	3.6	V
Ambient temperature		–40	25	85	°C
SMBus (SDA, SCL)				3.6	V
Supply noise up to 50 MHz ⁽¹⁾				100	mVp-p

- Allowed supply noise (mVp-p sine wave) under typical conditions.

6.4 Thermal Information

THERMAL METRIC ⁽¹⁾		DS100MB203	UNIT
		NYJ (WQFN)	
		54 PINS	
R _{θJA}	Junction-to-ambient thermal resistance, No Airflow, 4 layer JEDEC	26.6	°C/W
R _{θJC(top)}	Junction-to-case (top) thermal resistance	10.8	°C/W
R _{θJB}	Junction-to-board thermal resistance	4.4	°C/W
Ψ _{JT}	Junction-to-top characterization parameter	0.2	°C/W
Ψ _{JB}	Junction-to-board characterization parameter	4.3	°C/W
R _{θJC(bot)}	Junction-to-case (bottom) thermal resistance	1.5	°C/W

- For more information about traditional and new thermal metrics, see the *Semiconductor and IC Package Thermal Metrics* application report, [SPRA953](#).

6.5 Electrical Characteristics⁽¹⁾⁽²⁾

PARAMETER		TEST CONDITIONS	MIN	TYP	MAX	UNIT
POWER						
PD	Power dissipation	EQ Enabled, VOD = 1 Vp-p, RESET = 0	VDD = 2.5-V supply	390	499	mW
			VIN = 3.3-V supply	515	684	mW
LVCMOS / LVTTTL DC SPECIFICATIONS						
V _{ih}	High-level input voltage		2	VDD		V
V _{il}	Low-level input voltage		0	0.8		V
V _{oh}	High-level output voltage (ALL_DONE pin)	I _{oh} = -4mA	2			V
V _{ol}	Low-level output voltage (ALL_DONE pin)	I _{ol} = 4mA			0.4	V
I _{ih}	Input high current (RESET pin)	VIN = 3.6 V, LVCMOS = 3.6 V	-15		15	μA
	Input high current with internal resistors (4-level input pin)	VIN = 3.6 V, LVCMOS = 3.6 V	20		150	μA
I _{il}	Input low current (RESET pin)	VIN = 3.6 V, LVCMOS = 0 V	-15		15	μA
	Input low current with internal resistors (4-level input pin)	VIN = 3.6 V, LVCMOS = 0 V	-160		-40	μA
CML RECEIVER INPUTS (IN_{n+}, IN_{n-})						
RL _{rx-diff}	RX differential return loss	0.05 - 1.25 GHz		-16		dB
		1.25 - 2.5 GHz		-16		dB
		2.5 - 4.0 GHz		-14		dB
RL _{rx-cm}	RX common-mode return loss	0.05 - 2.5 GHz		-12		dB
		2.5 - 4.0 GHz		-8		dB
Z _{rx-dc}	RX DC common-mode impedance	Tested at VDD = 2.5 V	40	50	60	Ω
Z _{rx-diff-dc}	RX DC differential mode impedance	Tested at VDD = 2.5 V	80	100	120	Ω
V _{rx-signal-det-diff-pp}	Signal detect assert level for active data signal	0101 pattern at 8 Gbps		180		mVp-p
V _{rx-idle-det-diff-pp}	Signal detect de-assert level for electrical idle	0101 pattern at 8 Gbps		110		mVp-p
HIGH-SPEED OUTPUTS						
V _{tx-diff-pp}	Output voltage differential swing	Differential measurement with OUT _{n+} and OUT _{n-} , terminated by 50 Ω to GND, AC-Coupled, VID = 1 Vp-p, DEM _x [1:0] = R, F ⁽³⁾	0.8	1	1.2	Vp-p
V _{tx-de-ratio_3.5}	TX de-emphasis ratio	VOD = 1 Vp-p, DEM _x [1:0] = R, F		-3.5		dB

- (1) Typical values represent most likely parametric norms at VDD = 2.5V, TA = 25°C., and at the Recommended Operation Conditions at the time of product characterization and are not ensured.
- (2) The Electrical Characteristics tables list ensured specifications under the listed Recommended Operating Conditions except as otherwise modified or specified by the Electrical Characteristics Conditions and/or Notes. Typical specifications are estimations only and are not ensured.
- (3) In GEN3 mode, the output VOD level is not fixed. It will be adjusted automatically based on the VID input amplitude level. The output VOD level set by DEM_x[1:0] in GEN3 mode is dependent on the VID level and the frequency content. The DS100MB203 repeater in GEN3 mode is designed to be transparent, so the TX-FIR (de-emphasis) is passed to the RX to support the PCIe GEN3 handshake negotiation link training.

Electrical Characteristics⁽¹⁾⁽²⁾ (continued)

PARAMETER		TEST CONDITIONS	MIN	TYP	MAX	UNIT
V _{tx-de-ratio_6}	TX de-emphasis ratio	VOD = 1 Vp-p, DEM_x[1:0] = F, 0		-6		dB
t _{TX-DJ}	Deterministic jitter	VID = 800 mV, PRBS15 pattern, 8.0 0.05 Gbps, VOD = 1 V, Ulpp EQ = 0x00, DE = 0 dB (no input or output trace loss)		0.05		Ulpp
t _{TX-RJ}	Random jitter	VID = 800 mV, 0101 pattern, 8.0 Gbps, 0.3 VOD = 1 V, ps RMS EQ = 0x00, DE = 0 dB, (no input or output trace loss)		0.3		ps RMS
T _{TX-RISE-FALL}	TX rise/fall time	20% to 80% of differential output voltage	35	45		ps
T _{RF-MISMATCH}	TX rise/fall mismatch	20% to 80% of differential output voltage		0.01	0.1	UI
RL _{TX-DIFF}	TX differential return loss	0.05 - 1.25 GHz		-16		dB
		1.25 - 2.5 GHz		-12		dB
		2.5 - 4 GHz		-11		dB
RL _{TX-CM}	TX common-mode return loss	0.05 - 2.5 GHz		-12		dB
		2.5 - 4 GHz		-8		dB
Z _{TX-DIFF-DC}	DC differential TX impedance			100		Ω
V _{TX-CM-AC-PP}	TX AC common-mode voltage	VOD = 1 Vp-p, DEM_x[1:0] = R, F			100	mVpp
I _{TX-SHORT}	TX short circuit current limit	Total current the transmitter can supply when shorted to VDD or GND		20		mA
V _{TX-CM-DC-ACTIVE-IDLE-DELTA}	Absolute delta of DC common-mode voltage during L0 and electrical idle				100	mV
V _{TX-CM-DC-LINE-DELTA}	Absolute delta of DC common-mode voltage between TX+ and TX-				25	mV
T _{TX-IDLE-DATA}	Max time to transition to differential DATA signal after IDLE	VID = 1 Vp-p, 8 Gbps		3.5		ns
T _{TX-DATA-IDLE}	Max time to transition to IDLE after differential DATA signal	VID = 1 Vp-p, 8 Gbps		6.2		ns
T _{PLHD/PHLD}	High-to-low and low-to-high differential propagation delay	EQ = 00 ⁽⁴⁾		200		ps
T _{LSK}	Lane-to-lane skew	T = 25°C, VDD = 2.5 V		25		ps
T _{PPSK}	Part-to-part propagation delay skew	T = 25°C, VDD = 2.5 V		40		ps
T _{MUX-SWITCH}	Mux / switch time			100		ns
EQUALIZATION						
DJE1	Residual deterministic jitter at 10.3125 Gbps	35-in 4 mils FR4, VID = 0.8 Vp-p, PRBS15, EQ = 1F'h, DEM = 0 dB		0.3		UI
DJE2	Residual deterministic jitter at 8 Gbps	35-in 4 mils FR4, VID = 0.8 Vp-p, PRBS15, EQ = 1F'h, DEM = 0 dB		0.14		UI

(4) Propagation Delay measurements will change slightly based on the level of EQ selected. EQ = 00 will result in the shortest propagation delays.

Electrical Characteristics⁽¹⁾⁽²⁾ (continued)

PARAMETER		TEST CONDITIONS	MIN	TYP	MAX	UNIT
DJE3	Residual deterministic jitter at 5 Gbps	35-in 4 mils FR4, VID = 0.8 Vp-p, PRBS15, EQ = 1F'h, DEM = 0 dB		0.1		UI
DJE4	Residual deterministic jitter at 2.5 Gbps	35-in 4 mils FR4, VID = 0.8 Vp-p, PRBS15, EQ = 1F'h, DEM = 0 dB		0.05		UI
DJE5	Residual deterministic jitter at 10.3125 Gbps	10 meters 30 awg cable, VID = 0.8 Vp-p, PRBS15, EQ = 2F'h, DEM = 0 dB		0.3		UI
DJE6	Residual deterministic jitter at 8 Gbps	10 meters 30 awg cable, VID = 0.8 Vp-p, PRBS15, EQ = 2F'h, DEM = 0 dB		0.16		UI
DJE7	Residual deterministic jitter at 5 Gbps	10 meters 30 awg cable, VID = 0.8 Vp-p, PRBS15, EQ = 2F'h, DEM = 0 dB		0.1		UI
DJE8	Residual deterministic jitter at 2.5 Gbps	10 meters 30 awg cable, VID = 0.8 Vp-p, PRBS15, EQ = 2F'h, DEM = 0 dB		0.05		UI
DE-EMPHASIS (MODE = 0)						
DJD1	Residual deterministic jitter at 2.5 Gbps and 5.0 Gbps	10-in 4 mils FR4, VID = 0.8 Vp-p, PRBS15, EQ = 00, VOD = 1 Vp-p, DEM = -3.5 dB		0.1		UI
DJD2	Residual deterministic jitter at 2.5 Gbps and 5.0 Gbps	20-in 4 mils FR4, VID = 0.8 Vp-p, PRBS15, EQ = 00, VOD = 1 Vp-p, DEM = -9 dB		0.1		UI
DJD3	Residual deterministic jitter at 10.3125 Gbps	20-in 4 mils FR4, VID = 0.8 Vp-p, PRBS15, EQ = 00, VOD = 1 Vp-p, DEM = -9 dB		0.1		UI

6.6 Electrical Characteristics – Serial Management Bus Interface

Over recommended operating supply and temperature ranges unless other specified.

PARAMETER		TEST CONDITIONS	MIN	TYP	MAX	UNIT
SERIAL BUS INTERFACE DC SPECIFICATIONS						
V _{IL}	Data, clock input low voltage				0.8	V
V _{IH}	Data, clock input high voltage		2.1		3.6	V
I _{PULLUP}	Current through pullup resistor or current source	High power specification	4			mA
V _{DD}	Nominal bus voltage		2.375		3.6	V
I _{LEAK-Bus}	Input leakage per bus segment	See ⁽¹⁾	-200		200	μA
I _{LEAK-Pin}	Input leakage per device Pin			-15		μA
C _I	Capacitance for SDA and SCL	See ⁽¹⁾⁽²⁾			10	pF
R _{TERM}	External termination resistance pull to V _{DD} = 2.5 V ± 5% OR 3.3 V ± 10%	Pullup V _{DD} = 3.3 V ⁽¹⁾⁽²⁾⁽³⁾		2000		Ω
		Pullup V _{DD} = 2.5 V ⁽¹⁾⁽²⁾⁽³⁾		1000		Ω

(1) Recommended value.

(2) Recommended maximum capacitance load per bus segment is 400pF.

(3) Maximum termination voltage should be identical to the device supply voltage.

6.7 Timing Requirements – Serial Bus Interface

			MIN	NOM	MAX	UNIT
FSMB	Bus operating frequency	ENSMB = VDD (slave mode)			400	kHz
		ENSMB = FLOAT (master mode)	280	400	520	kHz
TBUF	Bus free time between stop and start condition		1.3			μs
THD:STA	Hold time after (repeated) start condition. After this period, the first clock is generated.	At I _{PULLUP} , maximum	0.6			μs
TSU:STA	Repeated start condition set-up time		0.6			μs
TSU:STO	Stop condition set-up time		0.6			μs
THD:DAT	Data hold time		0			ns
TSU:DAT	Data set-up time		100			ns
T _{LOW}	Clock low period		1.3			μs
T _{HIGH}	Clock high period	See ⁽¹⁾	0.6		50	μs
t _F	Clock / data fall time				300	ns
t _R	Clock / data rise time				300	ns
t _{POR}	Time in which a device must be operational after power-on reset	See ⁽¹⁾⁽²⁾			500	ms

(1) Compatible with SMBus 2.0 physical layer specification. See System Management Bus (SMBus) Specification Version 2.0, section 3.1.1 SMBus Common AC Specifications for details

(2) Specified by Design. Parameter not tested in production.

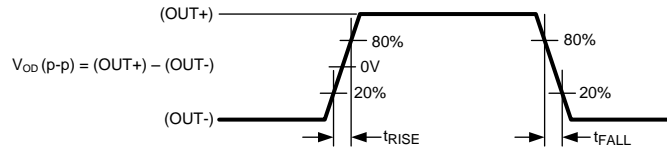

Figure 1. CML Output and Rise and FALL Transition Time

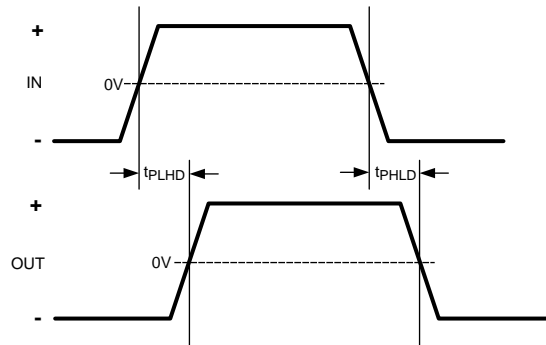

Figure 2. Propagation Delay Timing Diagram

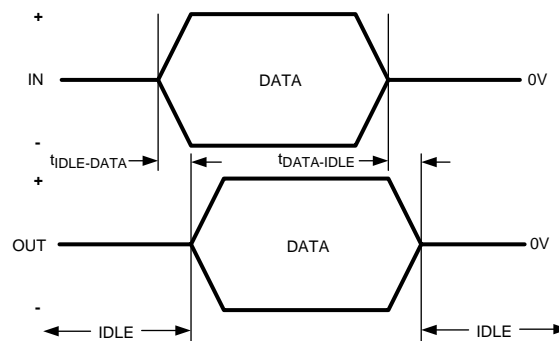

Figure 3. Transmit IDLE-DATA and DATA-IDLE Response Time

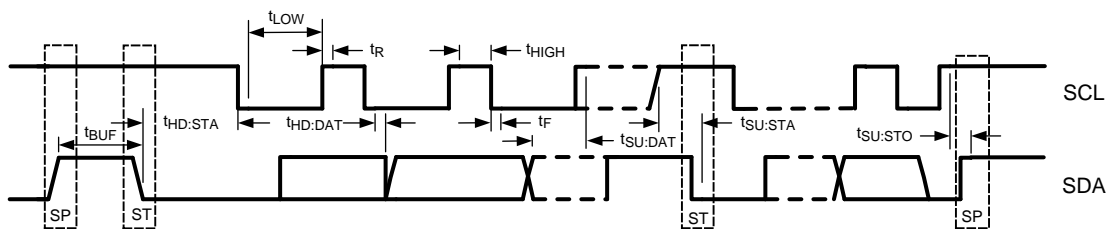

Figure 4. SMBus Timing Parameters

6.8 Typical Characteristics

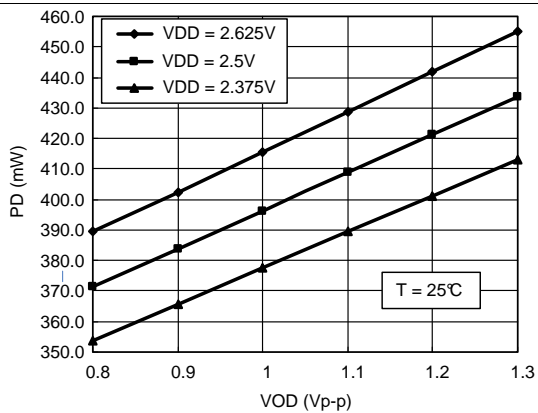

Figure 5. Power Dissipation (PD) vs Output Differential Voltage (VOD)

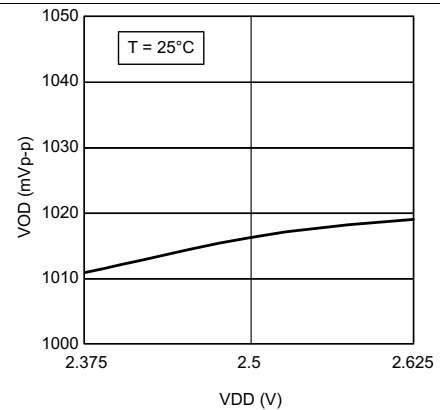

Figure 6. Output Differential Voltage (VOD = 1 Vp-p) vs Supply Voltage (VDD)

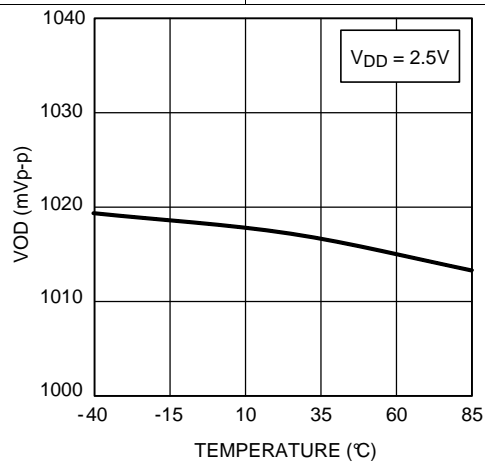

Figure 7. Output Differential Voltage (VOD = 1 Vp-p) vs Temperature

7 Detailed Description

7.1 Overview

The DS100MB203 is a dual lane 2:1 multiplexer and 1:2 switch or fan-out buffer with signal conditioning. The DS100MB203 compensates for lossy FR-4 printed-circuit-board backplanes and balanced cables. The DS100MB203 operates in 3 modes: Pin Control Mode (ENSMB = 0), SMBus Slave Mode (ENSMB = 1) and SMBus Master Mode (ENSMB = float) to load register information from external EEPROM; please refer to [SMBUS Master Mode](#) for additional information.

7.2 Functional Block Diagram

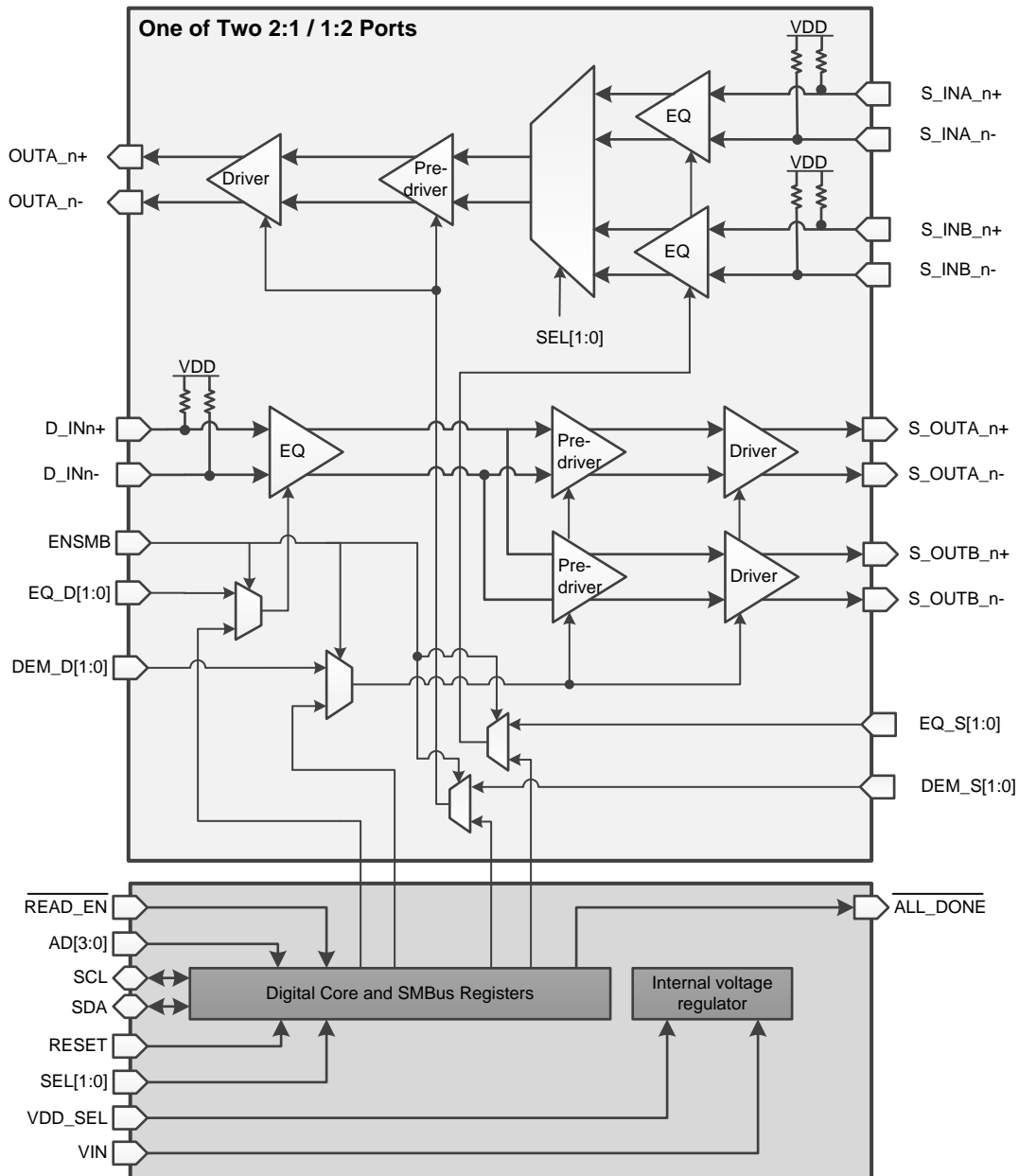

7.3 Feature Description

7.3.1 4-Level Input Configuration Guidelines

The 4-level input pins use a resistor divider to help set the four valid control levels and provide a wider range of control settings when ENSMB = 0. There is an internal 30-k Ω pullup and a 60-k Ω pulldown connected to the package pin. These resistors, together with the external resistor connection, combine to achieve the desired voltage level. By using the 1-k Ω pulldown, 20-k Ω pulldown, no connect, and 1-k Ω pullup, the optimal voltage levels for each of the four input states are achieved as shown in [Table 1](#).

Table 1. 4-Level Control Pin Settings

LEVEL	SETTING	RESULTING PIN VOLTAGE	
		3.3-V MODE	2.5-V MODE
0	Tie 1 k Ω to GND	0.1 V	0.08 V
R	Tie 20 k Ω to GND	$1/3 \times V_{IN}$	$1/3 \times V_{DD}$
F	Float (leave pin open)	$2/3 \times V_{IN}$	$2/3 \times V_{DD}$
1	Tie 1 k Ω to V_{IN} or V_{DD}	$V_{IN} - 0.05 \text{ V}$	$V_{DD} - 0.04 \text{ V}$

The typical 4-Level input thresholds are as follows:

- Internal Threshold between 0 and R = $0.2 \times V_{IN}$ or V_{DD}
- Internal Threshold between R and F = $0.5 \times V_{IN}$ or V_{DD}
- Internal Threshold between F and 1 = $0.8 \times V_{IN}$ or V_{DD}

In order to minimize the start-up current associated with the integrated 2.5-V regulator, the 1-k Ω pullup and pulldown resistors are recommended. If several four level inputs require the same setting, it is possible to combine two or more 1-k Ω resistors into a single lower value resistor. As an example, combining two inputs with a single 500- Ω resistor is a valid way to save board space.

7.4 Device Functional Modes

7.4.1 Pin Control Mode

When in pin mode (ENSMB = 0), the repeater is configurable with external pins. Equalization and de-emphasis can be selected through pin for each side independently. When de-emphasis is asserted VOD is automatically adjusted per [Table 3](#). The receiver electrical idle detect threshold is also adjustable via the SD_TH pin.

7.4.2 SMBUS Mode

When in SMBus mode (ENSMB = 1), the VOD (output amplitude), equalization, de-emphasis, and termination disable features are all programmable on a individual lane basis, instead of grouped by A or B as in the pin mode case. Upon assertion of ENSMB the MODE, EQx and DEMx functions revert to register control immediately. The EQx and DEMx pins are converted to AD0-AD3 SMBus address inputs. The other external control pins remain active unless their respective registers are written to and the appropriate override bit is set, in which case they are ignored until ENSMB is driven low (pin mode). On power up and when ENSMB is driven low all registers are reset to their default state. If RESET is asserted while ENSMB is high, the registers retain their current state.

Equalization settings accessible through the pin controls were chosen to meet the needs of most applications. If additional fine tuning or adjustment is needed, additional equalization settings can be accessed through the SMBus registers. Each input has a total of 256 possible equalization settings. The tables show the 16 setting when the device is in pin mode. When using SMBus mode, the equalization, VOD and de-Emphasis levels are set by registers.

The input control pins have been enhanced to have 4 different levels and provide a wider range of control settings when ENSMB=0.

Device Functional Modes (continued)
Table 2. Equalizer Settings

LEVEL	EQ_D1 EQ_S1	EQ_D0 EQ_S0	EQ – 8 BITS [7:0]	dB AT 1.25 GHz	dB AT 2.5 GHz	dB AT 4 GHz	dB AT 5 GHz	SUGGESTED USE ⁽¹⁾
1	0	0	0000 0000 = 0x00	2.1	3.7	4.9	5.3	FR4 < 5 inch trace
2	0	R	0000 0001 = 0x01	3.4	5.8	7.9	8.7	FR4 5 inch 5–mil trace
3	0	Float	0000 0010 = 0x02	4.8	7.7	9.9	10.6	FR4 5 inch 4–mil trace
4	0	1	0000 0011 = 0x03	5.9	8.9	11.0	11.7	FR4 10 inch 5–mil trace
5	R	0	0000 0111 = 0x07	7.2	11.2	14.3	15.6	FR4 10 inch 4–mil trace
6	R	R	0001 0101 = 0x15	6.1	11.4	14.6	16.6	FR4 15 inch 4–mil trace
7	R	Float	0000 1011 = 0x0B	8.8	13.5	17.0	18.3	FR4 20 inch 4–mil trace
8	R	1	0000 1111 = 0x0F	10.2	15.0	18.5	19.7	FR4 25 to 30 inch 4–mil trace
9	Float	0	0101 0101 = 0x55	7.5	12.8	18.0	20.3	FR4 30 inch 4–mil trace
10	Float	R	0001 1111 = 0x1F	11.4	17.4	22.0	23.6	FR4 35 inch 4–mil trace
11	Float	Float	0010 1111 = 0x2F	13.0	19.7	24.4	25.8	10-m, 30-awg cable
12	Float	1	0011 1111 = 0x3F	14.2	21.1	25.8	27.0	10-m – 12-m cable
13	1	0	1010 1010 = 0xAA	13.8	21.7	27.4	29.1	
14	1	R	0111 1111 = 0x7F	15.6	23.5	29.0	30.7	
15	1	Float	1011 1111 = 0xBF	17.2	25.8	31.4	32.7	
16	1	1	1111 1111 = 0xFF	18.4	27.3	32.7	33.8	

(1) FR4 lengths are for reference only. FR4 lengths based on a 100-Ω differential stripline with 5-mil traces and 8-mil trace separation.

Table 3. De-Emphasis and Output Voltage Settings

LEVEL	DEM_D1 DEM_S1	DEM_D0 DEM_S0	VOD Vp-p	DEM dB	INNER AMPLITUDE Vp-p	SUGGESTED USE ⁽¹⁾
1	0	0	0.6	0	0.6	FR4 <5 inch 4–mil trace
2	0	R	0.8	0	0.8	FR4 <5 inch 4–mil trace
3	0	Float	0.8	–3.5	0.55	FR4 10 inch 4–mil trace
4	0	1	0.9	0	1.0	FR4 <5 inch 4–mil trace
5	R	0	0.9	–3.5	0.45	FR4 10 inch 4–mil trace
6	R	R	0.9	–6	0.5	FR4 15 inch 4–mil trace
7	R	Float	1.0	0	1.0	FR4 <5 inch 4–mil trace
8	R	1	1.0	–3.5	0.7	FR4 10 inch 4–mil trace
9	Float	0	1.0	–6	0.5	FR4 15 inch 4–mil trace
10	Float	R	1.1	0	1.1	FR4 <5 inch 4–mil trace
11	Float	Float	1.1	–3.5	0.7	FR4 10 inch 4–mil trace
12	Float	1	1.1	–6	0.55	FR4 15 inch 4–mil trace
13	1	0	1.2	0	1.2	FR4 <5 inch 4–mil trace
14	1	R	1.2	–3.5	0.8	FR4 10 inch 4–mil trace
15	1	Float	1.2	–6	0.6	FR4 15 inch 4–mil trace
16	1	1	1.2	–9	0.45	FR4 20 inch 4–mil trace

(1) The VOD output amplitude and DEM de-emphasis levels are set with the DEMD/S[1:0] pins.

Table 4. Input Termination Condition with RESET, INPUT_EN and SEL0 / SEL1

RESET	INPUT_EN	SEL0 SEL1	MODE	INPUT_TERM S_INA0, S_INA1	INPUT_TERM S_INB0, S_INB1	INPUT_TERM D_IN0, D_IN1
1	X	X	Low Power	High Z	High Z	High Z
0	0	X	Manual Mux Mode	50 Ω	50 Ω	50 Ω
0	R	X	Reserved	Reserved	Reserved	Reserved
0	F	0	Auto - continuous poll, DIN_B	High Z	Auto RX-Detect, output tests every 12 msec until detection occurs, input termination is high-z until detection; once detected input termination is 50 Ω	Auto RX-Detect, output tests every 12 msec until detection occurs, input termination is high-z until detection; once detected input termination is 50 Ω
0	F	R	Auto - continuous poll, DIN_B	High Z	Auto RX-Detect, output tests every 12 msec until detection occurs, input termination is high-z until detection; once detected input termination is 50 Ω	Auto RX-Detect, output tests every 12 msec until detection occurs, input termination is high-z until detection; once detected input termination is 50 Ω
0	F	F	Auto - continuous poll, DIN_A	Auto RX-Detect, output tests every 12 msec until detection occurs, input termination is high-z until detection; once detected input termination is 50 Ω	High Z	Auto RX-Detect, output tests every 12 msec until detection occurs, input termination is high-z until detection; once detected input termination is 50 Ω
0	F	1	Auto - continuous poll, DIN_A	Auto RX-Detect, output tests every 12 msec until detection occurs, input termination is high-z until detection; once detected input termination is 50 Ω	High Z	Auto RX-Detect, output tests every 12 msec until detection occurs, input termination is high-z until detection; once detected input termination is 50 Ω
0	1	X	Manual Fanout Mode	50 Ω	50 Ω	50 Ω

Table 5. Mux/Switch and FANOUT Control

SEL0	SEL1	INPUT_EN	DESCRIPTION OF CONNECTION PATH
0	0	0	D_OUT0 connects to S_INB0. D_OUT1 connects to S_INB1. D_IN0 connects to S_OUTB0. S_OUTA0 is in IDLE (output muted). D_IN1 connects to S_OUTB1. S_OUTA1 is in IDLE (output muted).
0	0	R	Reserved
0	0	F	D_OUT0 connects to S_INB0. D_OUT1 connects to S_INB1. D_IN0 connects to S_OUTB0. S_OUTA0 is in IDLE (output muted). D_IN1 connects to S_OUTB1. S_OUTA1 is in IDLE (output muted).
0	0	1	D_OUT0 connects to S_INB0. D_OUT1 connects to S_INB1. D_IN0 connects to S_OUTB0 and S_OUTA0. D_IN1 connects to S_OUTB1 and S_OUTA1.
R	R	0	D_OUT0 connects to S_INB0. D_OUT1 connects to S_INB1. D_IN0 connects to S_OUTA0. S_OUTB0 is in IDLE (output muted). D_IN1 connects to S_OUTA1. S_OUTB1 is in IDLE (output muted).
R	R	R	Reserved
R	R	F	D_OUT0 connects to S_INB0. D_OUT1 connects to S_INB1. D_IN0 connects to S_OUTA0. S_OUTB0 is in IDLE (output muted). D_IN1 connects to S_OUTA1. S_OUTB1 is in IDLE (output muted).
R	R	1	D_OUT0 connects to S_INB0. D_OUT1 connects to S_INB1. D_IN0 connects to S_OUTB0 and S_OUTA0. D_IN1 connects to S_OUTB1 and S_OUTA1.
F	F	0	D_OUT0 connects to S_INA0. D_OUT1 connects to S_INA1. D_IN0 connects to S_OUTB0. S_OUTA0 is in IDLE (output muted). D_IN1 connects to S_OUTB1. S_OUTA1 is in IDLE (output muted).
F	F	R	Reserved
F	F	F	D_OUT0 connects to S_INA0. D_OUT1 connects to S_INA1. D_IN0 connects to S_OUTB0. S_OUTA0 is in IDLE (output muted). D_IN1 connects to S_OUTB1. S_OUTA1 is in IDLE (output muted).
F	F	1	D_OUT0 connects to S_INA0. D_OUT1 connects to S_INA1. D_IN0 connects to S_OUTB0 and S_OUTA0. D_IN1 connects to S_OUTB1 and S_OUTA1.
1	1	0	D_OUT0 connects to S_INA0. D_OUT1 connects to S_INA1. D_IN0 connects to S_OUTA0. S_OUTB0 is in IDLE (output muted). D_IN1 connects to S_OUTA1. S_OUTB1 is in IDLE (output muted).
1	1	R	Reserved
1	1	F	D_OUT0 connects to S_INA0. D_OUT1 connects to S_INA1. D_IN0 connects to S_OUTA0. S_OUTB0 is in IDLE (output muted). D_IN1 connects to S_OUTA1. S_OUTB1 is in IDLE (output muted).
1	1	1	D_OUT0 connects to S_INA0. D_OUT1 connects to S_INA1. D_IN0 connects to S_OUTA0 and S_OUTB0. D_IN1 connects to S_OUTA1 and S_OUTB1.

7.5 Programming

7.5.1 SMBUS Master Mode

The DS100MB203 devices support reading directly from an external EEPROM device by implementing SMBus Master mode. When using the SMBus master mode, the DS100MB203 will read directly from specific location in the external EEPROM. When designing a system for using the external EEPROM, the user needs to follow these specific guidelines below.

NOTE

SEL0, SEL1 and INPUT_EN control are to be set with the external strap pins because there are no register bits to configure them.

- Set ENSMB = Float – enable the SMBUS master mode.
- The external EEPROM device address byte must be 0xA0'h and capable of 1-MHz operation at 2.5-V and 3.3-V supply. The maximum allowed size is 8 kbits (1024 bytes).
- Set the AD[3:0] inputs for SMBus address byte. When the AD[3:0] = 0000'b, the device address byte is B0'h.

When tying multiple DS100MB203 devices to the SDA and SCL bus, use these guidelines to configure the devices.

- Use SMBus AD[3:0] address bits so that each device can loaded its configuration from the EEPROM. Example below is for 4 device.
 U1: AD[3:0] = 0000 = 0xB0'h,
 U2: AD[3:0] = 0001 = 0xB2'h,
 U3: AD[3:0] = 0010 = 0xB4'h,
 U4: AD[3:0] = 0011 = 0xB6'h
- Use a pull-up resistor on SDA and SCL; value = 2 kΩ
- Daisy-chain READEN# (pin 26) and ALL_DONE# (pin 27) from one device to the next device in the sequence so that they do not compete for the EEPROM at the same time.
 1. Tie READEN# of the 1st device in the chain (U1) to GND
 2. Tie ALL_DONE# of U1 to READEN# of U2
 3. Tie ALL_DONE# of U2 to READEN# of U3
 4. Tie ALL_DONE# of U3 to READEN# of U4
 5. Optional: Tie ALL_DONE# output of U4 to a LED to show the devices have been loaded successfully

Below is an example of a 2 kbits (256 x 8-bit) EEPROM in hex format for the DS100MB203 device. The first 3 bytes of the EEPROM always contain a header common and necessary to control initialization of all devices connected to the I²C bus. CRC enable flag to enable/disable CRC checking. If CRC checking is disabled, a fixed pattern (8'hA5) is written/read instead of the CRC byte from the CRC location, to simplify the control. There is a MAP bit to flag the presence of an address map that specifies the configuration data start in the EEPROM. If the MAP bit is not present the configuration data start address is derived from the DS100MB203 address and the configuration data size. A bit to indicate an EEPROM size > 256 bytes is necessary to properly address the EEPROM. There are 37 bytes of data size for each DS100MB203 device.

```

:2000000000001000000407002FAD4002FAD4002FAD4002FAD409805F5A8005F5A8005F5AD0
:200020008005F5A80000545400000000000000000000000000000000000000000000000000F6
:200060000000000000000000000000000000000000000000000000000000000000000000080
:200080000000000000000000000000000000000000000000000000000000000000000000060
:2000A0000000000000000000000000000000000000000000000000000000000000000000040
:2000C0000000000000000000000000000000000000000000000000000000000000000000020
:2000E0000000000000000000000000000000000000000000000000000000000000000000000
:2000400000000000000000000000000000000000000000000000000000000000000000000A0
    
```

NOTE

The maximum EEPROM size supported is 8 kbits (1024 x 8 bits). For more information in regards to EEPROM programming and the hex format, see [SNLA228](#).

7.6 Register Maps

7.6.1 System Management Bus (SMBus) and Configuration Registers

The System Management Bus interface is compatible to SMBus 2.0 physical layer specification. ENSMB = 1 k Ω to VDD to enable SMBus slave mode and allow access to the configuration registers.

The DS100MB203 has the AD[3:0] inputs in SMBus mode. These pins are the user set SMBUS slave address inputs. The AD[3:0] pins have internal pull-down. When left floating or pulled low the AD[3:0] = 0000'b, the device default address byte is B0'h. Based on the SMBus 2.0 specification, the DS100MB203 has a 7-bit slave address. The LSB is set to 0'b (for a WRITE). The device supports up to 16 address bytes, which can be set with the AD[3:0] inputs. Below are the 16 addresses.

Table 6. Device Slave Address Bytes

AD[3:0] SETTINGS	ADDRESS BYTES (HEX)
0000	B0
0001	B2
0010	B4
0011	B6
0100	B8
0101	BA
0110	BC
0111	BE
1000	C0
1001	C2
1010	C4
1011	C6
1100	C8
1101	CA
1110	CC
1111	CE

The SDA, SCL pins are 3.3-V tolerant, but are not 5-V tolerant. External pullup resistor is required on the SDA. The resistor value can be from 1 k Ω to 5 k Ω depending on the voltage, loading and speed. The SCL may also require an external pullup resistor and it depends on the Host that drives the bus.

7.6.1.1 Transfer of Data Through the SMBus

During normal operation the data on SDA must be stable during the time when SCL is high.

There are three unique states for the SMBus:

- **START:** A high-to-low transition on SDA while SCL is high indicates a message START condition.
- **STOP:** A low-to-high transition on SDA while SCL is high indicates a message STOP condition.
- **IDLE:** If SCL and SDA are both high for a time exceeding t_{BUF} from the last detected STOP condition or if they are high for a total exceeding the maximum specification for t_{HIGH} then the bus will transfer to the IDLE state.

7.6.1.2 SMBus Transactions

The device supports WRITE and READ transactions. See [Table 8](#) for register address, type (Read/Write, Read Only), default value and function information.

7.6.1.3 Writing a Register

To write a register, the following protocol is used (see SMBus 2.0 specification).

1. The host drives a START condition, the 7-bit SMBus address, and a 0 indicating a WRITE.
2. The device (slave) drives the ACK bit (0).
3. The host drives the 8-bit register address.
4. The device drives an ACK bit (0).
5. The host drive the 8-bit data byte.
6. The device drives an ACK bit (0).
7. The host drives a STOP condition.

The WRITE transaction is completed, the bus goes IDLE and communication with other SMBus devices may now occur.

7.6.1.4 Reading a Register

To read a register, the following protocol is used (see SMBus 2.0 specification).

1. The host drives a START condition, the 7-bit SMBus address, and a 0 indicating a WRITE.
2. The device (Slave) drives the ACK bit (0).
3. The host drives the 8-bit register address.
4. The device drives an ACK bit (0).
5. The host drives a START condition.
6. The host drives the 7-bit SMBus Address, and a 1 indicating a READ.
7. The device drives an ACK bit 0.
8. The device drives the 8-bit data value (register contents).
9. The host drives a NACK bit 1 indicating end of the READ transfer.
10. The host drives a STOP condition.

The READ transaction is completed, the bus goes IDLE and communication with other SMBus devices may now occur.

Please see [Table 7](#) for more information.

Table 7. SMBUS Slave Mode Register Map

ADDRESS	REGISTER NAME	BIT	FIELD	TYPE	DEFAULT	EEPROM REG BIT	DESCRIPTION	
0x00	Observation	7	Reserved	R/W	0x00		Set bit to 0	
		6:3	Address Bit AD[3:0]	R			Observation of AD[3:0] bits [6]: AD3 [5]: AD2 [4]: AD1 [3]: AD0	
		2	EEPROM Read Done	R			1 = Device completed the read from external EEPROM	
		1	Block Reset	R/W			1: Block bit 0 from resetting the registers; self clearing.	
		0	Reset	R/W			SMBus reset 1: Reset registers to default value; self clearing.	
0x01	PWDN Channels	7:0	PWDN CHx	R/W	0x00	Yes	Power down per channel [7]: CH7 (NC – S_OUTB1) [6]: CH6 (D_IN1 – S_OUTA1) [5]: CH5 (NC – S_OUTB0) [4]: CH4 (D_IN0 – S_OUTA0) [3]: CH3 (D_OUT1 – S_INB1) [2]: CH2 (NC – S_INA1) [1]: CH1 (D_OUT0 – S_INB0) [0]: CH0 (NC – S_INA0) 0x00 = all channels enabled 0xFF = all channels disabled Note: Override PWDN pin and enable register control through Reg 0x02[0]	
0x02	Override RESET Control	7	Reserved	R/W	0x00		Set bit to 0	
		6	Reserved				Set bit to 0	
		5:2	Reserved				Yes	Set bits to 0
		1	Reserved					Set bit to 0
		0	Override RESET				Yes	1: Block RESET pin control; use Reg_01 to configure. 0: Allow RESET pin control.
0x03	Reserved	7:0	Reserved	R/W	0x00		Set bits to 0	
0x04	Reserved	7:0	Reserved	R/W	0x00	Yes	Set bits to 0	
0x05	Reserved	7:0	Reserved	R/W	0x00		Reserved	
0x06	Slave Register Control	7:5	Reserved	R/W	0x10		Set bits to 0	
		4	Reserved				Yes	Set bit to 1
		3	Register Enable					1 = Enable SMBus slave mode register control 0 = Disable SMBus register control Note: In order to change VOD, DEM, and EQ of the channels in slave mode, this bit must be set to 1.
		2:0	Reserved					Set bits to 0

Table 7. SMBUS Slave Mode Register Map (continued)

ADDRESS	REGISTER NAME	BIT	FIELD	TYPE	DEFAULT	EEPROM REG BIT	DESCRIPTION
0x07	Reserved	7:1	Reserved	R/W	0x01		Set bits to 0
		0	Reserved				Set bit to 1
0x08	Override Pin Control	7	Reserved	R/W	0x00		Set bit to 0
		6:4	Reserved			Yes	Set bits to 0
		3	Override RXDET			Yes	1 = Block RXDET pin control (register control enabled) 0 = Allow RXDET pin control (register control disabled)
		2	Override MODE			Yes	1: Block MODE pin control; use register to configure. 0: Allow MODE pin control
		1:0	Reserved			Yes	Set bits to 0
0x09	Reserved	7:0	Reserved	R/W	0x00		Set bits to 0
0x0A	Reserved	7:0	Reserved	R	0x00		
0x0B	Reserved	7	Reserved	R/W	0x70		Set bit to 0
		6:0	Reserved	R/W		Yes	Set bits to 111 0000'b
0x0C-0x0D	Reserved	7:0	Reserved	R/W	0x00		Set bits to 0
0x0E	CH0 NC – S_INA0 RXDET	7:6	Reserved	R/W	0x00		Set bits to 0
		5:4	Reserved			Yes	Set bits to 0
		3:2	RXDET			Yes	00'b = Input is Hi-Z impedance 01'b = Auto Rx-Detect, outputs test every 12 ms for 600 ms (50 times) then stops; termination is Hi-Z until detection; once detected input termination is 50 Ω 10'b = Auto Rx-Detect, outputs test every 12 ms until detection occurs; termination is Hi-Z until detection; once detected input termination is 50 Ω 11'b = Input is 50 Ω Note: Override RXDET pin and enable register control via Reg 0x08[3]
		1:0	Reserved				Set bits to 0
0x0F	CH0 NC – S_INA0 EQ	7:0	EQ Control	R/W	0x2F	Yes	EQ Control - total of 256 levels. See Table 2 .
0x10	Reserved	7:0	Reserved	R/W	0xAD	Yes	
0x11	CH0 NC – S_INA0 Reserved	7:3	Reserved	R/W	0x02		Set bits to 0
		2:0	Reserved			Yes	
0x12	CH0 NC – S_INA0 Reserved	7	Reserved	R/W	0x00	Yes	Set bit to 0
		6:4	Reserved				Set bits to 0
		3:2	Reserved			Yes	Set bits to 0
		1:0	Reserved			Yes	Set bits to 0

Table 7. SMBUS Slave Mode Register Map (continued)

ADDRESS	REGISTER NAME	BIT	FIELD	TYPE	DEFAULT	EEPROM REG BIT	DESCRIPTION
0x13-0x14	Reserved	7:0	Reserved	R/W	0x00		Set bits to 0
0x15	CH1 D_OUT0 – S_INB0 RXDET	7:6	Reserved	R/W	0x00		Set bits to 0
		5:4	Reserved			Yes	Set bits to 0
		3:2	RXDET			Yes	00'b = Input is Hi-Z impedance 01'b = Auto Rx-Detect, outputs test every 12 ms for 600 ms (50 times) then stops; termination is Hi-Z until detection; once detected input termination is 50 Ω 10'b = Auto Rx-Detect, outputs test every 12 ms until detection occurs; termination is Hi-Z until detection; once detected input termination is 50 Ω 11'b = Input is 50 Ω Note: Override RXDET pin and enable register control through Reg 0x08[3]
		1:0	Reserved				Set bits to 0
0x16	CH1 D_OUT0 – S_INB0 EQ	7:0	EQ Control	R/W	0x2F	Yes	EQ Control - total of 256 levels. See Table 2 .
0x17	CH1 D_OUT0 – S_INB0 VOD	7	Short Circuit Protection	R/W	0xAD	Yes	1 = Enable the short circuit protection 0 = Disable the short circuit protection
		6	MODE Control			Yes	1 = PCIe GEN 1/2, 10GE 0 = PCIe GEN 3, 10G-KR Note: Override the MODE pin in Reg_08.
		5:3	Reserved			Yes	Set bits to 101'b
		2:0	VOD Control			Yes	VOD Control: 000'b = 0.6 V 001'b = 0.7 V 010'b = 0.8 V 011'b = 0.9 V 100'b = 1.0 V 101'b = 1.1 (default) 110'b = 1.2 111'b = 1.3

Table 7. SMBUS Slave Mode Register Map (continued)

ADDRESS	REGISTER NAME	BIT	FIELD	TYPE	DEFAULT	EEPROM REG BIT	DESCRIPTION
0x18	CH1 D_OUT0 – S_INB0 DEM	7	RXDET Status	R	0x02		Observation bit for RXDET CH1 1 = Input 50 Ω terminated to VDD 0 = Input is Hi-Z
		6:5	Reserved				Set bits to 0
		4:3	Reserved				Set bits to 0
		2:0	DEM Control	R/W		Yes	DEM Control 000'b = 0 dB 001'b = -1.5 dB 010'b = -3.5 dB (default) 011'b = -5 dB 100'b = -6 dB 101'b = -8 dB 110'b = -9 dB 111'b = -12 dB
0x19	CH1 D_OUT0 – S_INB0 Reserved	7	Reserved	R/W	0x00	Yes	Set bit to 0
		6:4	Reserved				Set bits to 0
		3:2	Reserved			Yes	Set bits to 0
		1:0	Reserved			Yes	Set bits to 0
0x1A-0x1B	Reserved	7:0	Reserved	R/W	0x00		Set bits to 0
0x1C	CH2 NC – S_INA1 RXDET	7:6	Reserved	R/W	0x00		Set bits to 0
		5:4	Reserved			Yes	Set bits to 0
		3:2	RXDET			Yes	00'b = Input is Hi-Z impedance 01'b = Auto Rx-Detect, outputs test every 12 ms for 600 ms (50 times) then stops; termination is Hi-Z until detection; once detected input termination is 50 Ω 10'b = Auto Rx-Detect, outputs test every 12 ms until detection occurs; termination is Hi-Z until detection; once detected input termination is 50 Ω 11'b = Input is 50 Ω Note: Override RXDET pin and enable register control through Reg 0x08[3]
		1:0	Reserved				Set bits to 0
0x1D	CH2 NC – S_INA1 EQ	7:0	EQ Control	R/W	0x2F	Yes	EQ Control - total of 256 levels. See Table 2 .
0x1E	Reserved	7:0	Reserved	R/W	0xAD	Yes	
0x1F	Reserved	7:3	Reserved	R/W	0x02		
		2:0				Yes	

Table 7. SMBUS Slave Mode Register Map (continued)

ADDRESS	REGISTER NAME	BIT	FIELD	TYPE	DEFAULT	EEPROM REG BIT	DESCRIPTION
0x20	CH2 NC – S_INA1 Reserved	7	Reserved	R/W	0x00	Yes	Set bit to 0
		6:4	Reserved				Set bits to 0
		3:2	Reserved			Yes	Set bits to 0
		1:0	Reserved			Yes	Set bits to 0
0x21-0x22	Reserved	7:0	Reserved	R/W	0x00		Set bits to 0
0x23	CH3 D_OUT1 – S_INB1 RXDET	7:6	Reserved	R/W	0x00		Set bits to 0
		5:4	Reserved			Yes	Set bits to 0
		3:2	RXDET			Yes	00'b = Input is Hi-Z impedance 01'b = Auto Rx-Detect, outputs test every 12 ms for 600 ms (50 times) then stops; termination is Hi-Z until detection; once detected input termination is 50 Ω 10'b = Auto Rx-Detect, outputs test every 12 ms until detection occurs; termination is Hi-Z until detection; once detected input termination is 50 Ω 11'b = Input is 50 Ω Note: Override RXDET pin and enable register control through Reg 0x08[3]
		1:0	Reserved				Set bits to 0
0x24	CH3 D_OUT1 – S_INB1 EQ	7:0	EQ Control	R/W	0x2F	Yes	EQ Control - total of 256 levels. See Table 2 .
0x25	CH3 D_OUT1 – S_INB1 VOD	7	Short Circuit Protection	R/W	0xAD	Yes	1 = Enable the short circuit protection 0 = Disable the short circuit protection
		6	MODE Control			Yes	1 = PCIe GEN 1/2, 10GE 0 = PCIe GEN 3, 10G-KR Note: override the MODE pin in Reg_08.
		5:3	Reserved			Yes	Set bits to 101'b
		2:0	VOD Control			Yes	VOD Control: 000'b = 0.6 V 001'b = 0.7 V 010'b = 0.8 V 011'b = 0.9 V 100'b = 1.0 V 101'b = 1.1 (default) 110'b = 1.2 111'b = 1.3

Table 7. SMBUS Slave Mode Register Map (continued)

ADDRESS	REGISTER NAME	BIT	FIELD	TYPE	DEFAULT	EEPROM REG BIT	DESCRIPTION
0x26	CH3 D_OUT1 – S_INB1 DEM	7	RXDET Status	R	0x02		Observation bit for RXDET CH3 - CHB_3 1 = Input 50 Ω terminated to VDD 0 = Input is Hi-Z
		6:5	Reserved				Set bits to 0
		4:3	Reserved				Set bits to 0
		2:0	DEM Control	R/W		Yes	DEM Control 000'b = 0 dB 001'b = -1.5 dB 010'b = -3.5 dB (default) 011'b = -5 dB 100'b = -6 dB 101'b = -8 dB 110'b = -9 dB 111'b = -12 dB
0x27	CH3 D_OUT1 – S_INB1 Reserved	7	Reserved	R/W	0x00	Yes	Set bit to 0
		6:4	Reserved				Set bits to 0
		3:2	Reserved			Yes	Set bits to 0
		1:0	Reserved			Yes	Set bits to 0
0x28	Signal Detect Status Control	7	Reserved	R/W	0x0C		Set bit to 0
		6	Reserved			Yes	Set bit to 0
		5:4	High SD_TH Status			Yes	Enable higher range of signal detect status thresholds [5]: CH0 - CH3 [4]: CH4 - CH7
		3:2	Fast Signal Detect Status			Yes	Enable fast signal detect status [3]: CH0 - CH3 [2]: CH4 - CH7 Note: In fast signal detect, assert/de-assert response occurs after approximately 3-4 ns
		1:0	Reduced SD Status Gain			Yes	Enable reduced signal detect status gain [1]: CH0 - CH3 [0]: CH4 - CH7
0x29-0x2A	Reserved	7:0	Reserved	R/W	0x00		Set bits to 0

Table 7. SMBUS Slave Mode Register Map (continued)

ADDRESS	REGISTER NAME	BIT	FIELD	TYPE	DEFAULT	EEPROM REG BIT	DESCRIPTION
0x2B	CH4 D_IN0 – S_OUTA0 RXDET	7:6	Reserved	R/W	0x00		Set bits to 0
		5:4	Reserved			Yes	Set bits to 0
		3:2	RXDET			Yes	00'b = Input is Hi-Z impedance 01'b = Auto Rx-Detect, outputs test every 12 ms for 600 ms (50 times) then stops; termination is Hi-Z until detection; once detected input termination is 50 Ω 10'b = Auto Rx-Detect, outputs test every 12 ms until detection occurs; termination is Hi-Z until detection; once detected input termination is 50 Ω 11'b = Input is 50 Ω Note: Override RXDET pin and enable register control through Reg 0x08[3]
		1:0	Reserved				Set bits to 0
0x2C	CH4 D_IN0 – S_OUTA0 EQ	7:0	EQ Control	R/W	0x2F	Yes	EQ Control - total of 256 levels. See Table 2 .
0x2D	CH4 D_IN0 – S_OUTA0 VOD	7	Short Circuit Protection	R/W	0xAD	Yes	1 = Enable the short circuit protection 0 = Disable the short circuit protection
		6	MODE Control			Yes	1 = PCIe GEN 1/2, 10GE 0 = PCIe GEN 3, 10G-KR Note: override the MODE pin in Reg_08.
		5:3	Reserved			Yes	Set bits to 101'b
		2:0	VOD Control			Yes	VOD Control: 000'b = 0.6 V 001'b = 0.7 V 010'b = 0.8 V 011'b = 0.9 V 100'b = 1.0 V 101'b = 1.1 (default) 110'b = 1.2 111'b = 1.3

Table 7. SMBUS Slave Mode Register Map (continued)

ADDRESS	REGISTER NAME	BIT	FIELD	TYPE	DEFAULT	EEPROM REG BIT	DESCRIPTION
0x2E	CH4 D_IN0 – S_OUTA0 DEM	7	RXDET Status	R	0x02		Observation bit for RXDET CH4 - CHA_0 1 = Input 50 Ω terminated to VDD 0 = Input is Hi-Z
		6:5	Reserved				Set bits to 0
		4:3	Reserved				Set bits to 0
		2:0	DEM Control	R/W		Yes	DEM Control 000'b = 0 dB 001'b = -1.5 dB 010'b = -3.5 dB (default) 011'b = -5 dB 100'b = -6 dB 101'b = -8 dB 110'b = -9 dB 111'b = -12 dB
0x2F	CH4 D_IN0 – S_OUTA0 Reserved	7	Reserved	R/W	0x00	Yes	Set bit to 0
		6:4	Reserved				Set bits to 0
		3:2	Reserved			Yes	Set bits to 0
		1:0	Reserved			Yes	Set bits to 0
0x30-0x31	Reserved	7:0	Reserved	R/W	0x00		Set bits to 0
0x32	Reserved	7:6	Reserved	R/W	0x00		Set bits to 0
		5:4	Reserved			Yes	Set bits to 0
		3:2	Reserved			Yes	Set bits to 0
		1:0	Reserved				Set bits to 0
0x33	CH5 NC – S_OUTB0 Reserved	7:0	Reserved	R/W	0x2F	Yes	

Table 7. SMBUS Slave Mode Register Map (continued)

ADDRESS	REGISTER NAME	BIT	FIELD	TYPE	DEFAULT	EEPROM REG BIT	DESCRIPTION
0x34	CH5 NC – S_OUTB0 VOD	7	Short Circuit Protection	R/W	0xAD	Yes	1 = Enable the short circuit protection 0 = Disable the short circuit protection
		6	MODE Control			Yes	1 = PCIe GEN 1/2, 10GE 0 = PCIe GEN 3, 10G-KR Note: Override the MODE pin in Reg_08.
		5:3	Reserved			Yes	Set bits to 101'b
		2:0	VOD Control			Yes	VOD Control: 000'b = 0.6 V 001'b = 0.7 V 010'b = 0.8 V 011'b = 0.9 V 100'b = 1.0 V 101'b = 1.1 (default) 110'b = 1.2 111'b = 1.3
0x35	CH5 NC – S_OUTB0 DEM	7	RXDET Status	R	0x02		Observation bit for RXDET CH5 - CHA1 1 = Input 50 Ω terminated to VDD 0 = Input is Hi-Z
		6:5	Reserved			Set bits to 0	
		4:3	Reserved			Set bits to 0	
		2:0	DEM Control	R/W		Yes	DEM Control 000'b = 0 dB 001'b = -1.5 dB 010'b = -3.5 dB (default) 011'b = -5 dB 100'b = -6 dB 101'b = -8 dB 110'b = -9 dB 111'b = -12 dB
0x36	CH5 NC – S_OUTB0 Reserved	7	Reserved	R/W	0x00	Yes	Set bit to 0
		6:4	Reserved				Set bits to 0
		3:2	Reserved			Yes	Set bits to 0
		1:0	Reserved			Yes	Set bits to 0
0x37-0x38	Reserved	7:0	Reserved	R/W	0x00		Set bits to 0

Table 7. SMBUS Slave Mode Register Map (continued)

ADDRESS	REGISTER NAME	BIT	FIELD	TYPE	DEFAULT	EEPROM REG BIT	DESCRIPTION
0x39	CH6 D_IN1 – S_OUTA1 RXDET	7:6	Reserved	R/W	0x00		Set bits to 0
		5:4	Reserved			Yes	Set bits to 0
		3:2	RXDET			Yes	00'b = Input is Hi-Z impedance 01'b = Auto Rx-Detect, outputs test every 12 ms for 600 ms (50 times) then stops; termination is Hi-Z until detection; once detected input termination is 50 Ω 10'b = Auto Rx-Detect, outputs test every 12 ms until detection occurs; termination is Hi-Z until detection; once detected input termination is 50 Ω 11'b = Input is 50 Ω Note: Override RXDET pin and enable register control through Reg 0x08[3]
		1:0	Reserved				Set bits to 0
0x3A	CH6 D_IN1 – S_OUTA1 EQ	7:0	EQ Control	R/W	0x2F	Yes	EQ Control - total of 256 levels. See Table 2 .
0x3B	CH6 D_IN1 – S_OUTA1 VOD	7	Short Circuit Protection	R/W	0xAD	Yes	1 = Enable the short circuit protection 0 = Disable the short circuit protection
		6	MODE Control			Yes	1 = PCIe GEN 1/2, 10GE 0 = PCIe GEN 3, 10G-KR Note: override the MODE pin in Reg_08.
		5:3	Reserved			Yes	Set bits to 0101'b
		2:0	VOD Control			Yes	VOD Control: 000'b = 0.6 V 001'b = 0.7 V 010'b = 0.8 V 011'b = 0.9 V 100'b = 1.0 V 101'b = 1.1 (default) 110'b = 1.2 111'b = 1.3

Table 7. SMBUS Slave Mode Register Map (continued)

ADDRESS	REGISTER NAME	BIT	FIELD	TYPE	DEFAULT	EEPROM REG BIT	DESCRIPTION
0x3C	CH6 D_IN1 – S_OUTA1 DEM	7	RXDET Status	R	0x02		Observation bit for RXDET CH6 - CHA_2 1 = Input 50 Ω terminated to VDD 0 = Input is Hi-Z
		6:5	Reserved				Set bits to 0
		4:3	Reserved				Set bits to 0
		2:0	DEM Control	R/W		Yes	DEM Control 000'b = 0 dB 001'b = -1.5 dB 010'b = -3.5 dB (default) 011'b = -5 dB 100'b = -6 dB 101'b = -8 dB 110'b = -9 dB 111'b = -12 dB
0x3D	CH6 D_IN1 – S_OUTA1 Reserved	7	Reserved	R/W	0x00	Yes	Set bit to 0
		6:4	Reserved				Set bits to 0
		3:2	Reserved			Yes	Set bits to 0
		1:0	Reserved			Yes	Set bits to 0
0x3E-0x3F	Reserved	7:0	Reserved	R/W	0x00		Set bits to 0
0x40	Reserved	7:6	Reserved	R/W	0x00		Set bits to 0
		5:4	Reserved			Yes	Set bits to 0
		3:2	Reserved			Yes	Set bits to 0
		1:0	Reserved				Set bits to 0
0x41	CH7 NC – S_OUTB1 EQ	7:0	EQ Control	R/W	0x2F	Yes	EQ Control - total of 256 levels. See Table 2 .

Table 7. SMBUS Slave Mode Register Map (continued)

ADDRESS	REGISTER NAME	BIT	FIELD	TYPE	DEFAULT	EEPROM REG BIT	DESCRIPTION
0x42	CH7 NC – S_OUTB1 VOD	7	Short Circuit Protection	R/W	0xAD	Yes	1 = Enable the short circuit protection 0 = Disable the short circuit protection
		6	MODE Control			Yes	1 = PCIe GEN 1/2, 10GE 0 = PCIe GEN 3, 10G-KR Note: Override the MODE pin in Reg_08.
		5:3	Reserved			Yes	Set bits to 101'b
		2:0	VOD Control			Yes	VOD Control: 000'b = 0.6 V 001'b = 0.7 V 010'b = 0.8 V 011'b = 0.9 V 100'b = 1.0 V 101'b = 1.1 (default) 110'b = 1.2 111'b = 1.3
0x43	CH7 NC – S_OUTB1 DEM	7	RXDET Status	R	0x02		Observation bit for RXDET CH7 - CHA_3 1 = Input 50 Ω terminated to VDD 0 = Input is Hi-Z
		6:5	Reserved			Set bits to 0	
		4:3	Reserved			Set bits to 0	
		2:0	DEM Control	R/W		Yes	DEM Control 000'b = 0 dB 001'b = -1.5 dB 010'b = -3.5 dB (default) 011'b = -5 dB 100'b = -6 dB 101'b = -8 dB 110'b = -9 dB 111'b = -12 dB
0x44	CH7 NC – S_OUTB1 Reserved	7	Reserved	R/W	0x00	Yes	Set bit to 0.
		6:4	Reserved				Set bits to 0.
		3:2	Reserved			Yes	Set bits to 0.
		1:0	Reserved			Yes	Set bits to 0.
0x45	Reserved	7:0	Reserved	R/W	0x00		Set bits to 0.
0x46	Reserved	7:0	Reserved	R/W	0x38		Set bits to 0x38
0x47	Reserved	7:4	Reserved	R/W	0x00		Set bits to 0.
		3:0	Reserved			Yes	Set bits to 0.
0x48	Reserved	7:6	Reserved	R/W	0x05	Yes	Set bits to 0.
		5:0	Reserved	R/W			Set bits to 00 0101'b
0x49-0x4B	Reserved	7:0	Reserved	R/W	0x00		Set bits to 0.

Table 7. SMBUS Slave Mode Register Map (continued)

ADDRESS	REGISTER NAME	BIT	FIELD	TYPE	DEFAULT	EEPROM REG BIT	DESCRIPTION
0x4C	Reserved	7:3	Reserved	R/W	0x00	Yes	Set bits to 0.
		2:1	Reserved	R/W			Set bits to 0.
		0	Reserved	R/W		Yes	Set bits to 0.
0x4D-0x50	Reserved	7:0	Reserved	R/W	0x00		Set bits to 0.
0x51	Device ID	7:5	VERSION	R	0x46		010'b
		4:0	ID				0 0110'b
0x52-0x55	Reserved	7:0	Reserved	R/W	0x00		Set bits to 0.
0x56	Reserved	7:0	Reserved	R/W	0x10		Set bits to 0x10
0x57	Reserved	7:0	Reserved	R/W	0x64		Set bits to 0x64
0x58	Reserved	7:0	Reserved	R/W	0x21		Set bits to 0x21
		7:1	Reserved	R/W	0x00		Set bits to 0.
0	Reserved	Yes	Set bit to 0.				
0x5A	Reserved	7:0	Reserved	R/W	0x54	Yes	Set bits to 0x54
0x5B	Reserved	7:0	Reserved	R/W	0x54	Yes	Set bits to 0x54
0x5C-0x5D	Reserved	7:0	Reserved	R/W	0x00		Set bits to 0.
0x5E	Override SEL[1:0] and INPUT_EN	7:3	Reserved	R/W	0x00		Set bits to 0.
		2	Override SEL1 pin				1: Block SEL1 pin control; use Reg_5F to configure. 0: Allow SEL1 pin control
		1	Override SEL0 pin				1: Block SEL0 pin control; use Reg_5F to configure. 0: Allow SEL0 pin control
		0	Override INPUT_EN pin				1: Block INPUT_EN pin control; use Reg_5F to configure. 0: Allow INPUT_EN pin control
0x5F	Control SEL[1:0] and INPUT_EN	7:6	SEL1 Control	R/W	0x00		Select for Lane 1. 00: 0 - selects input S_INB1±, output S_OUTB1±. 01: 20 kΩ to GND - selects input S_INB1±, output S_OUTA1± 10: FLOAT - selects input S_INA1±, output S_OUTB1± 11: 1 - selects input S_INA1±, output S_OUTA1±.
		5:4	SEL0 Control				Select for Lane 0. 00: 0 - selects input S_INB0±, output S_OUTB0±. 01: 20kΩ to GND - selects input S_INB0±, output S_OUTA0± 10: FLOAT - selects input S_INA0±, output S_OUTB0± 11: 1 - selects input S_INA0±, output S_OUTA0±.
		3:2	INPUT_EN Control				1: Block SEL0 pin control; use Reg_5F to configure. 0: Allow SEL0 pin control
		1:0	Reserved				1: Block INPUT_EN pin control; use Reg_5F to configure. 0: Allow INPUT_EN pin control

Table 8. EEPROM Register Map With Default Value

EEPROM ADDRESS BYTE		BIT 7	BIT 6	BIT 5	BIT 4	BIT 3	BIT 2	BIT 1	BIT 0
Description	0x00	CRC_EN	Address Map Present	EEPROM > 256 Bytes	Reserved	DEVICE COUNT[3]	DEVICE COUNT[2]	DEVICE COUNT[1]	DEVICE COUNT[0]
Default Value		0	0	0	0	0	0	0	0
Description	0x01	Reserved	Reserved	Reserved	Reserved	Reserved	Reserved	Reserved	Reserved
Default Value		0	0	0	0	0	0	0	0
Description	0x02	Max EEPROM Burst size[7]	Max EEPROM Burst size[6]	Max EEPROM Burst size[5]	Max EEPROM Burst size[4]	Max EEPROM Burst size[3]	Max EEPROM Burst size[2]	Max EEPROM Burst size[1]	Max EEPROM Burst size[0]
Default Value		0	0	0	0	0	0	0	0
Description	0x03	PWDN_CH7	PWDN_CH6	PWDN_CH5	PWDN_CH4	PWDN_CH3	PWDN_CH2	PWDN_CH1	PWDN_CH0
SMBus Register		0x01[7]	0x01[6]	0x01[5]	0x01[4]	0x01[3]	0x01[2]	0x01[1]	0x01[0]
Default Value		0	0	0	0	0	0	0	0
Description	0x04	Reserved	Reserved	Reserved	Reserved	Ovrd_RESET	Reserved	Reserved	Reserved
SMBus Register		0x02[5]	0x02[4]	0x02[3]	0x02[2]	0x02[0]	0x04[7]	0x04[6]	0x04[5]
Default Value		0	0	0	0	0	0	0	0
Description	0x05	Reserved	Reserved	Reserved	Reserved	Reserved	Reserved	Reserved	Reserved
SMBus Register		0x04[4]	0x04[3]	0x04[2]	0x04[1]	0x04[0]	0x06[4]	0x08[6]	0x08[5]
Default Value		0	0	0	0	0	1	0	0
Description	0x06	Reserved	Ovrd_RXDET	Ovrd_MODE	Reserved	Reserved	Reserved	Reserved	Reserved
SMBus Register		0x08[4]	0x08[3]	0x08[2]	0x08[1]	0x08[0]	0x0B[6]	0x0B[5]	0x0B[4]
Default Value		0	0	0	0	0	1	1	1
Description	0x07	Reserved	Reserved	Reserved	Reserved	Reserved	Reserved	CH0_RXDET_1	CH0_RXDET_0
SMBus Register		0x0B[3]	0x0B[2]	0x0B[1]	0x0B[0]	0x0E[5]	0x0E[4]	0x0E[3]	0x0E[2]
Default Value		0	0	0	0	0	0	0	0
Description	0x08	CH0_EQ_7	CH0_EQ_6	CH0_EQ_5	CH0_EQ_4	CH0_EQ_3	CH0_EQ_2	CH0_EQ_1	CH0_EQ_0
SMBus Register		0x0F[7]	0x0F[6]	0x0F[5]	0x0F[4]	0x0F[3]	0x0F[2]	0x0F[1]	0x0F[0]
Default Value		0	0	1	0	1	1	1	1

Table 8. EEPROM Register Map With Default Value (continued)

EEPROM ADDRESS BYTE		BIT 7	BIT 6	BIT 5	BIT 4	BIT 3	BIT 2	BIT 1	BIT 0
Description		Reserved	Reserved	Reserved	Reserved	Reserved	Reserved	Reserved	Reserved
SMBus Register	0x09	0x10[7]	0x10[6]	0x10[5]	0x10[4]	0x10[3]	0x10[2]	0x10[1]	0x10[0]
Default Value		0xAD	1	0	1	0	1	1	0
Description		Reserved	Reserved	Reserved	Reserved	Reserved	Reserved	Reserved	Reserved
SMBus Register	0x0A	0x11[2]	0x11[1]	0x11[0]	0x12[7]	0x12[3]	0x12[2]	0x12[1]	0x12[0]
Default Value		0x40	0	1	0	0	0	0	0
Description		Reserved	Reserved	CH1_RXDET_1	CH1_RXDET_0	CH1_EQ_7	CH1_EQ_6	CH1_EQ_5	CH1_EQ_4
SMBus Register	0x0B	0x15[5]	0x15[4]	0x15[3]	0x15[2]	0x16[7]	0x16[6]	0x16[5]	0x16[4]
Default Value		0x02	0	0	0	0	0	0	1
Description		CH1_EQ_3	CH1_EQ_2	CH1_EQ_1	CH1_EQ_0	CH1_SCP	CH1_Sel_MODE	Reserved	Reserved
SMBus Register	0x0C	0x16[3]	0x16[2]	0x16[1]	0x16[0]	0x17[7]	0x17[6]	0x17[5]	0x17[4]
Default Value		0xFA	1	1	1	1	1	0	1
Description		Reserved	CH1_VOD_2	CH1_VOD_1	CH1_VOD_0	CH1_DEM_2	CH1_DEM_1	CH1_DEM_0	Reserved
SMBus Register	0x0D	0x17[3]	0x17[2]	0x17[1]	0x17[0]	0x18[2]	0x18[1]	0x18[0]	0x19[7]
Default Value		0xD4	1	1	0	1	0	1	0
Description		Reserved	Reserved	Reserved	Reserved	Reserved	Reserved	CH2_RXDET_1	CH2_RXDET_0
SMBus Register	0x0E	0x19[3]	0x19[2]	0x19[1]	0x19[0]	0x1C[5]	0x1C[4]	0x1C[3]	0x1C[2]
Default Value		0x00	0	0	0	0	0	0	0
Description		CH2_EQ_7	CH2_EQ_6	CH2_EQ_5	CH2_EQ_4	CH2_EQ_3	CH2_EQ_2	CH2_EQ_1	CH2_EQ_0
SMBus Register	0x0F	0x1D[7]	0x1D[6]	0x1D[5]	0x1D[4]	0x1D[3]	0x1D[2]	0x1D[1]	0x1D[0]
Default Value		0x2F	0	0	1	0	1	1	1
Description		Reserved	Reserved	Reserved	Reserved	Reserved	Reserved	Reserved	Reserved
SMBus Register	0x10	0x1E[7]	0x1E[6]	0x1E[5]	0x1E[4]	0x1E[3]	0x1E[2]	0x1E[1]	0x1E[0]
Default Value		0xAD	1	0	1	0	1	1	0
Description		Reserved	Reserved	Reserved	Reserved	Reserved	Reserved	Reserved	Reserved
SMBus Register	0x11	0x1F[2]	0x1F[1]	0x1F[0]	0x20[7]	0x20[3]	0x20[2]	0x20[1]	0x20[0]
Default Value		0x40	0	1	0	0	0	0	0

Table 8. EEPROM Register Map With Default Value (continued)

EEPROM ADDRESS BYTE		BIT 7	BIT 6	BIT 5	BIT 4	BIT 3	BIT 2	BIT 1	BIT 0
Description	0x12	Reserved	Reserved	CH3_RXDET_1	CH3_RXDET_0	CH3_EQ_7	CH3_EQ_6	CH3_EQ_5	CH3_EQ_4
SMBus Register		0x23[5]	0x23[4]	0x23[3]	0x23[2]	0x24[7]	0x24[6]	0x24[5]	0x24[4]
Default Value		0	0	0	0	0	0	1	0
Description	0x13	CH3_EQ_3	CH3_EQ_2	CH3_EQ_1	CH3_EQ_0	CH3_SCP	CH3_Sel_MODE	Reserved	Reserved
SMBus Register		0x24[3]	0x24[2]	0x24[1]	0x24[0]	0x25[7]	0x25[6]	0x25[5]	0x25[4]
Default Value		1	1	1	1	1	0	1	0
Description	0x14	Reserved	CH3_VOD_2	CH3_VOD_1	CH3_VOD_0	CH3_DEM_2	CH3_DEM_1	CH3_DEM_0	Reserved
SMBus Register		0x25[3]	0x25[2]	0x25[1]	0x25[0]	0x26[2]	0x26[1]	0x26[0]	0x27[7]
Default Value		1	1	0	1	0	1	0	0
Description	0x15	Reserved	Reserved	Reserved	Reserved	Reserved	hi_idle_SD CH0-3	hi_idle_SD CH4-7	fast_SD CH0-3
SMBus Register		0x27[3]	0x27[2]	0x27[1]	0x27[0]	0x28[6]	0x28[5]	0x28[4]	0x28[3]
Default Value		0	0	0	0	0	0	0	1
Description	0x16	fast_SD CH4-7	lo_gain_SD CH0-3	lo_gain_SD CH4-7	Reserved	Reserved	CH4_RXDET_1	CH4_RXDET_0	CH4_EQ_7
SMBus Register		0x28[2]	0x28[1]	0x28[0]	0x2B[5]	0x2B[4]	0x2B[3]	0x2B[2]	0x2C[7]
Default Value		1	0	0	0	0	0	0	0
Description	0x17	CH4_EQ_6	CH4_EQ_5	CH4_EQ_4	CH4_EQ_3	CH4_EQ_2	CH4_EQ_1	CH4_EQ_0	CH4_SCP
SMBus Register		0x2C[6]	0x2C[5]	0x2C[4]	0x2C[3]	0x2C[2]	0x2C[1]	0x2C[0]	0x2D[7]
Default Value		0	1	0	1	1	1	1	1
Description	0x18	CH4_Sel_MODE	Reserved	Reserved	Reserved	CH4_VOD_2	CH4_VOD_1	CH4_VOD_0	CH4_DEM_2
SMBus Register		0x2D[6]	0x2D[5]	0x2D[4]	0x2D[3]	0x2D[2]	0x2D[1]	0x2D[0]	0x2E[2]
Default Value		0	1	0	1	1	0	1	0
Description	0x19	CH4_DEM_1	CH4_DEM_0	Reserved	Reserved	Reserved	Reserved	Reserved	Reserved
SMBus Register		0x2E[1]	0x2E[0]	0x2F[7]	0x2F[3]	0x2F[2]	0x2F[1]	0x2F[0]	0x32[5]
Default Value		1	0	0	0	0	0	0	0
Description	0x1A	Reserved	Reserved	Reserved	Reserved	Reserved	Reserved	Reserved	Reserved
SMBus Register		0x32[4]	0x32[3]	0x32[2]	0x33[7]	0x33[6]	0x33[5]	0x33[4]	0x33[3]
Default Value		0	0	0	0	0	1	0	1

Table 8. EEPROM Register Map With Default Value (continued)

EEPROM ADDRESS BYTE		BIT 7	BIT 6	BIT 5	BIT 4	BIT 3	BIT 2	BIT 1	BIT 0
Description	0x1B	Reserved	Reserved	Reserved	CH5_SCP	CH5_Sel_MODE	Reserved	Reserved	Reserved
SMBus Register		0x33[2]	0x33[1]	0x33[0]	0x34[7]	0x34[6]	0x34[5]	0x34[4]	0x34[3]
Default Value		0xF5	1	1	1	1	0	1	0
Description	0x1C	CH5_VOD_2	CH5_VOD_1	CH5_VOD_0	CH5_DEM_2	CH5_DEM_1	CH5_DEM_0	Reserved	Reserved
SMBus Register		0x34[2]	0x34[1]	0x34[0]	0x35[2]	0x35[1]	0x35[0]	0x36[7]	0x36[3]
Default Value		0xA8	1	0	1	0	1	0	0
Description	0x1D	Reserved	Reserved	Reserved	Reserved	Reserved	CH6_RXDET_1	CH6_RXDET_0	CH6_EQ_7
SMBus Register		0x36[2]	0x36[1]	0x36[0]	0x39[5]	0x39[4]	0x39[3]	0x39[2]	0x3A[7]
Default Value		0x00	0	0	0	0	0	0	0
Description	0x1E	CH6_EQ_6	CH6_EQ_5	CH6_EQ_4	CH6_EQ_3	CH6_EQ_2	CH6_EQ_1	CH6_EQ_0	CH6_SCP
SMBus Register		0x3A[6]	0x3A[5]	0x3A[4]	0x3A[3]	0x3A[2]	0x3A[1]	0x3A[0]	0x3B[7]
Default Value		0x5F	0	1	0	1	1	1	1
Description	0x1F	CH6_Sel_MODE	Reserved	Reserved	Reserved	CH6_VOD_2	CH6_VOD_1	CH6_VOD_0	CH6_DEM_2
SMBus Register		0x3B[6]	0x3B[5]	0x3B[4]	0x3B[3]	0x3B[2]	0x3B[1]	0x3B[0]	0x3C[2]
Default Value		0x5A	0	1	0	1	1	0	1
Description	0x20	CH6_DEM_1	CH6_DEM_0	Reserved	Reserved	Reserved	Reserved	Reserved	Reserved
SMBus Register		0x3C[1]	0x3C[0]	0x3D[7]	0x3D[3]	0x3D[2]	0x3D[1]	0x3D[0]	0x40[5]
Default Value		0x80	1	0	0	0	0	0	0
Description	0x21	Reserved	Reserved	Reserved	Reserved	Reserved	Reserved	Reserved	Reserved
SMBus Register		0x40[4]	0x40[3]	0x40[2]	0x41[7]	0x41[6]	0x41[5]	0x41[4]	0x41[3]
Default Value		0x05	0	0	0	0	0	1	0
Description	0x22	Reserved	Reserved	Reserved	CH7_SCP	CH7_Sel_MODE	Reserved	Reserved	Reserved
SMBus Register		0x41[2]	0x41[1]	0x41[0]	0x42[7]	0x42[6]	0x42[5]	0x42[4]	0x42[3]
Default Value		0xF5	1	1	1	1	0	1	0
Description	0x23	CH7_VOD_2	CH7_VOD_1	CH7_VOD_0	CH7_DEM_2	CH7_DEM_1	CH7_DEM_0	Reserved	Reserved
SMBus Register		0x42[2]	0x42[1]	0x42[0]	0x43[2]	0x43[1]	0x43[0]	0x44[7]	0x44[3]
Default Value		0xA8	1	0	1	0	1	0	0

Table 8. EEPROM Register Map With Default Value (continued)

EEPROM ADDRESS BYTE		BIT 7	BIT 6	BIT 5	BIT 4	BIT 3	BIT 2	BIT 1	BIT 0
Description	0x24	Reserved	Reserved	Reserved	Reserved	Reserved	Reserved	Reserved	Reserved
SMBus Register		0x44[2]	0x44[1]	0x44[0]	0x47[3]	0x47[2]	0x47[1]	0x47[0]	0x48[7]
Default Value		0x00	0	0	0	0	0	0	0
Description	0x25	Reserved	Reserved	Reserved	Reserved	Reserved	Reserved	Reserved	Reserved
SMBus Register		0x48[6]	0x4C[7]	0x4C[6]	0x4C[5]	0x4C[4]	0x4C[3]	0x4C[0]	0x59[0]
Default Value		0x00	0	0	0	0	0	0	0
Description	0x26	Reserved	Reserved	Reserved	Reserved	Reserved	Reserved	Reserved	Reserved
SMBus Register		0x5A[7]	0x5A[6]	0x5A[5]	0x5A[4]	0x5A[3]	0x5A[2]	0x5A[1]	0x5A[0]
Default Value		0x54	0	1	0	1	0	1	0
Description	0x27	Reserved	Reserved	Reserved	Reserved	Reserved	Reserved	Reserved	Reserved
SMBus Register		0x5B[7]	0x5B[6]	0x5B[5]	0x5B[4]	0x5B[3]	0x5B[2]	0x5B[1]	0x5B[0]
Default Value		0x54	0	1	0	1	0	1	0

8 Application and Implementation

8.1 Application Information

8.1.1 General Recommendations

The DS100MB203 is a high-performance circuit capable of delivering excellent performance. Pay careful attention to the details associated with high-speed design as well as providing a clean power supply. Refer to the information below and Revision 4 of the LVDS Owner's Manual for more detailed information on high speed design tips to address signal integrity design issues.

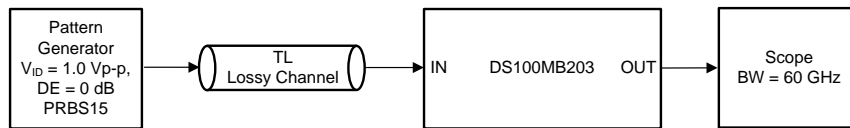

Figure 8. Test Set-Up Connections Diagram

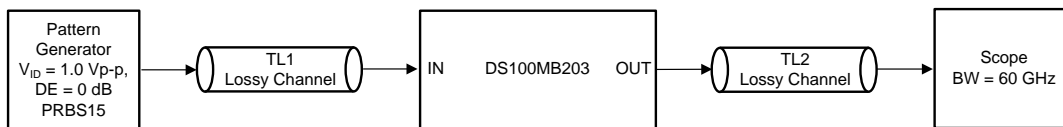

Figure 9. Test Set-Up Connections Diagram

8.2 Typical Application

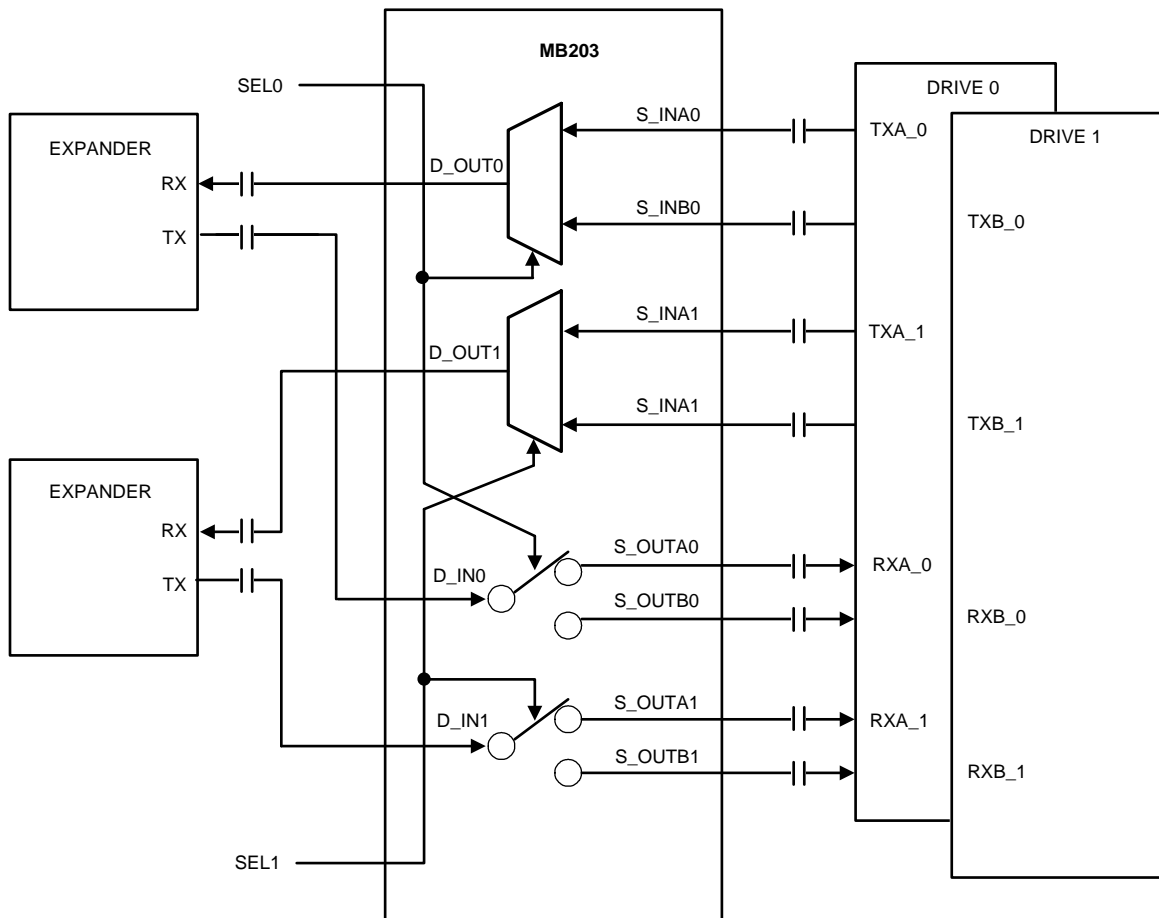

Figure 10. Storage Application

8.2.1 Design Requirements

As with any high-speed design, there are many factors which influence the overall performance. Below are a list of critical areas for consideration and study during design.

- Use 100-Ω impedance traces. Generally these are very loosely coupled to ease routing length differences.
- Place AC-coupling capacitors near to the receiver end of each channel segment to minimize reflections.
- The maximum body size for AC-coupling capacitors is 0402.
- Back-drill connector vias and signal vias to minimize stub length.
- Use Reference plane vias to ensure a low inductance path for the return current.

8.2.2 Detailed Design Procedure

The DS100MB203 is designed to be placed at an offset location with respect to the overall channel attenuation. In order to optimize performance, the repeater requires tuning to extend the reach of the cable or trace length while also recovering a solid eye opening. To tune the mux-buffer, the settings mentioned in [Table 2](#) and [Table 3](#) are recommended as a default starting point for most applications. Once these settings are configured, additional tuning of the EQ and, to a lesser extent, VOD may be required to optimize the repeater performance for each specific application environment.

Examples of the repeater performance as a generic high-speed datapath repeater are shown in the performance curves in the [Application Curves](#) section.

Typical Application (continued)

8.2.3 Application Curves

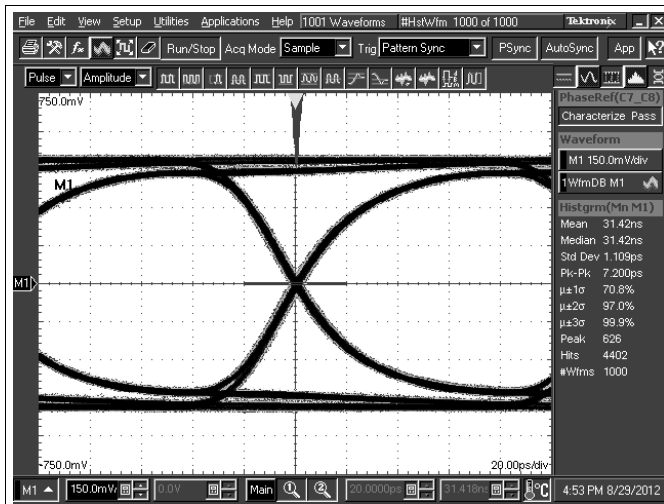

**Figure 11. TL = 10-inch 5-mil FR4 Trace, 8 Gbps
MB203 Settings: EQ[1:0] = 0, F = 02'h, DEM[1:0] = 0, 1**

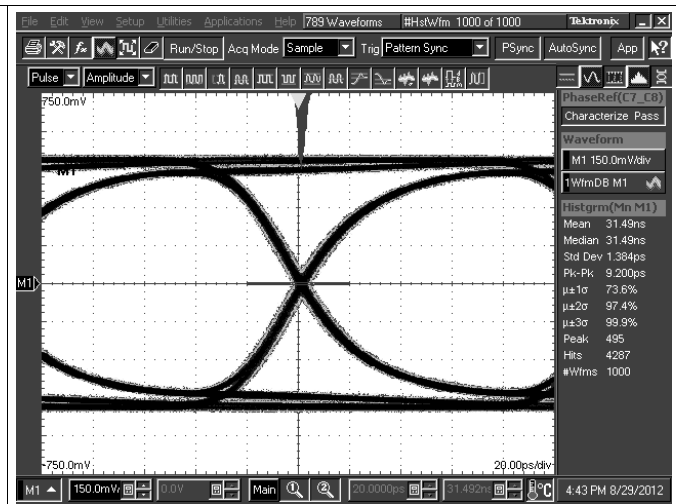

**Figure 12. TL = 20-inch 5-mil FR4 Trace, 8 Gbps
MB203 Settings: EQ[1:0] = 0, 1 = 03'h, DEM[1:0] = 0, 1**

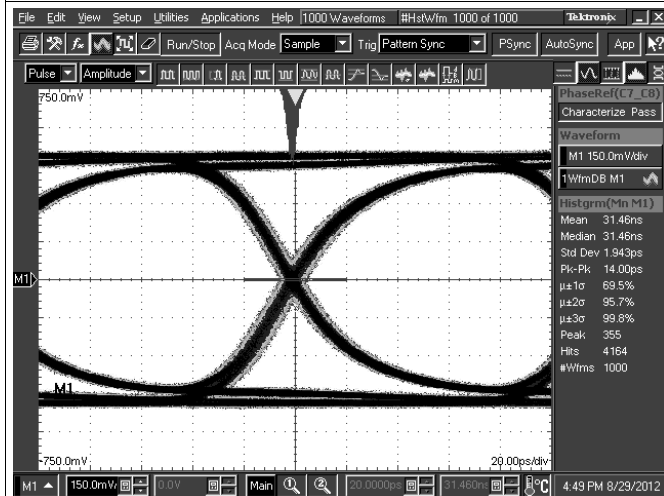

**Figure 13. TL = 30-inch 5-mil FR4 Trace, 8 Gbps
MB203 Settings: EQ[1:0] = R, 0 = 07'h, DEM[1:0] = 0, 1**

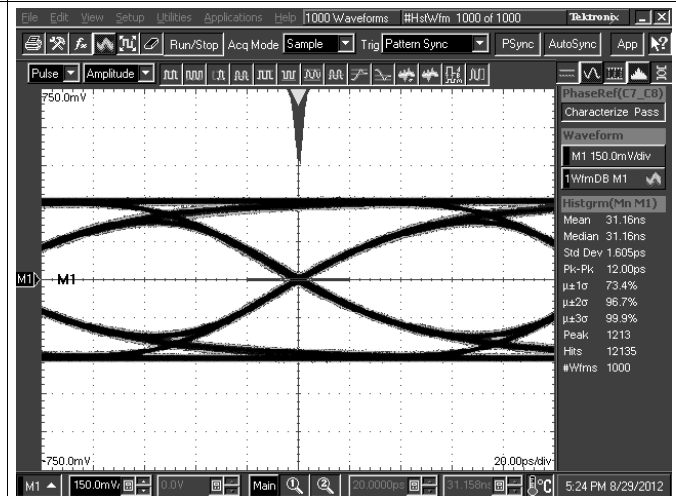

**Figure 14. TL1 = 20-inch 5-mil FR4 Trace, TL2 = 10-inch
5-mil FR4 trace, 8 Gbps
MB203 Settings: EQ[1:0] = R, 1 = 03'h, DEM[1:0] = R, 0**

9 Power Supply Recommendations

9.1 Power Supply Bypassing

The DS100MB203 has an optional internal voltage regulator to provide the 2.5-V supply to the device. In 3.3-V mode, the VIN pin = 3.3 V is used to supply power to the device and the VDD pins should be left open. The internal regulator will provide the 2.5 V to the VDD pins of the device and a 0.1-μF capacitor is needed at each of the five VDD pins for power supply de-coupling (total capacitance should be ≤ 0.5 μF), and the VDD pins should be left open. The VDD_SEL pin must be tied to GND to enable the internal regulator. In 2.5-V mode, the VIN pin should be left open and 2.5-V supply must be applied to the VDD pins. The VDD_SEL pin must be left open (no connect) to disable the internal regulator.

The DS100MB203 can be configured for 2.5-V operation or 3.3-V operation. The lists below outline required connections for each supply selection.

Power Supply Bypassing (continued)

For 3.3-V mode of operation, use the following steps:

1. Tie VDD_SEL = 0 with 1-k Ω resistor to GND.
2. Feed 3.3-V supply into VIN pin. Local 1.0- μ F decoupling at VIN is recommended.
3. See information on VDD bypass below.
4. SDA and SCL pins should connect pullup resistor to VIN
5. Any 4-Level input which requires a connection to Logic 1 should use a 1-k Ω resistor to VIN

For 2.5-V mode of operation, use the following steps:

1. VDD_SEL = Float
2. VIN = Float
3. Feed 2.5-V supply into VDD pins.
4. See information on VDD bypass below.
5. SDA and SCL pins connect pullup resistor to VDD for 2.5-V uC SMBus IO
6. SDA and SCL pins connect pullup resistor to VDD for 3.3-V uC SMBus IO
7. Any 4-Level input which requires a connection to Logic 1 should use a 1-k Ω resistor to VDD

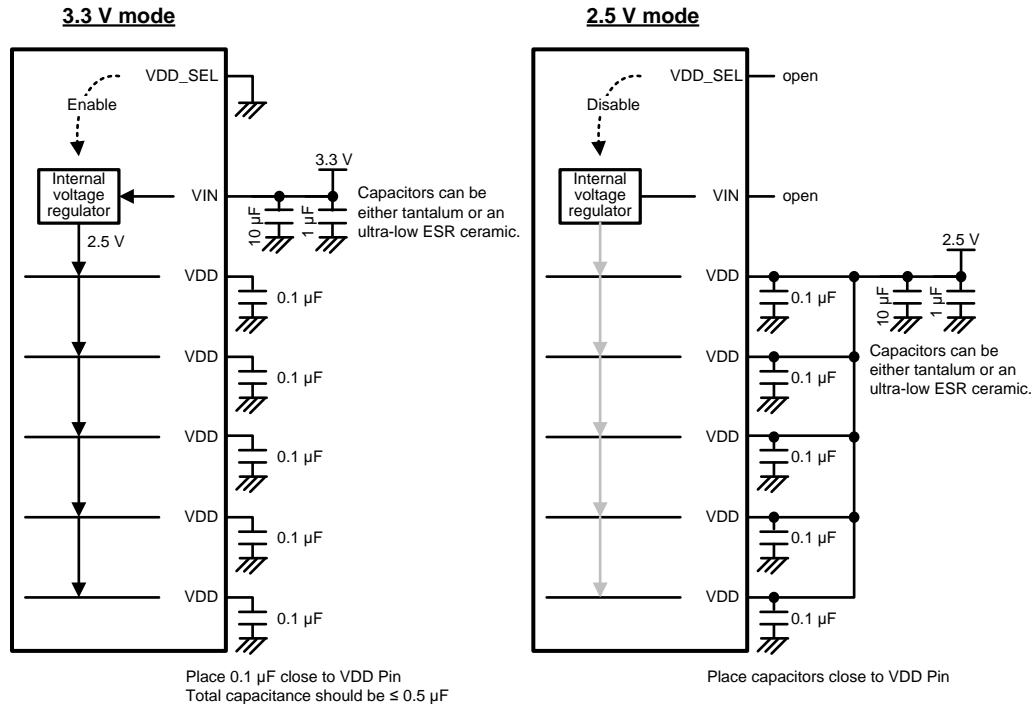

Figure 15. 3.3-V or 2.5-V Supply Connection Diagram

Two approaches are recommended to ensure that the DS100MB203 is provided with an adequate power supply bypass. First, the supply (V_{DD}) and ground (GND) pins should be connected to power planes routed on adjacent layers of the printed-circuit-board. Second, pay careful attention to supply bypassing through the proper use of bypass capacitors is required. A 0.1- μ F bypass capacitor should be connected to each V_{DD} pin such that the capacitor is placed as close as possible to the device. Small body size capacitors (such as 0402) reduce the parasitic inductance of the capacitor and also help in placement close to the V_{DD} pin. If possible, the layer thickness of the dielectric should be minimized so that the V_{DD} and GND planes create a low inductance supply with distributed capacitance.

10 Layout

10.1 Layout Guidelines

The differential inputs and outputs are designed with 100-Ω differential terminations. Therefore, they should be connected to interconnects with controlled differential impedance of approximately 85-110 Ω. It is preferable to route differential lines primarily on one layer of the board, particularly for the input traces. The use of vias should be avoided if possible. If vias must be used, they should be used sparingly and must be placed symmetrically for each side of a given differential pair. Whenever differential vias are used, the layout must also provide for a low inductance path for the return currents as well. Route the differential signals away from other signals and noise sources on the printed-circuit-board. To minimize the effects of crosstalk, a 5:1 ratio or greater should be maintained between inter-pair spacing and trace width. See AN-1187 *Leadless Leadframe Package (LLP) Application Report (SNOA401)* for additional information on QFN (WQFN) packages.

The DS100MB203 pinout promotes easy high-speed routing and layout. To optimize DS100MB203 performance refer to the following guidelines:

1. Place local VIN and VDD capacitors as close as possible to the device supply pins. Often the best location is directly under the DS100MB203 pins to reduce the inductance path to the capacitor. In addition, bypass capacitors may share a via with the DAP GND to minimize ground loop inductance.
2. Differential pairs going into or out of the DS100MB203 should have adequate pair-to-pair spacing to minimize crosstalk.
3. Use return current via connections to link reference planes locally. This ensures a low inductance return current path when the differential signal changes layers.
4. Optimize the via structure to minimize trace impedance mismatch.
5. Place GND vias around the DAP perimeter to ensure optimal electrical and thermal performance.
6. Use small body size AC coupling capacitors when possible—0402 or smaller size is preferred. The AC-coupling capacitors should be placed closer to the Rx on the channel.

[Figure 16](#) depicts different transmission line topologies which can be used in various combinations to achieve the optimal system performance. Impedance discontinuities at the differential via can be minimized or eliminated by increasing the swell around each hole and providing for a low inductance return current path. When the via structure is associated with thick backplane PCB, further optimization such as back drilling is often used to reduce the detrimental high-frequency effects of stubs on the signal path.

10.2 Layout Example

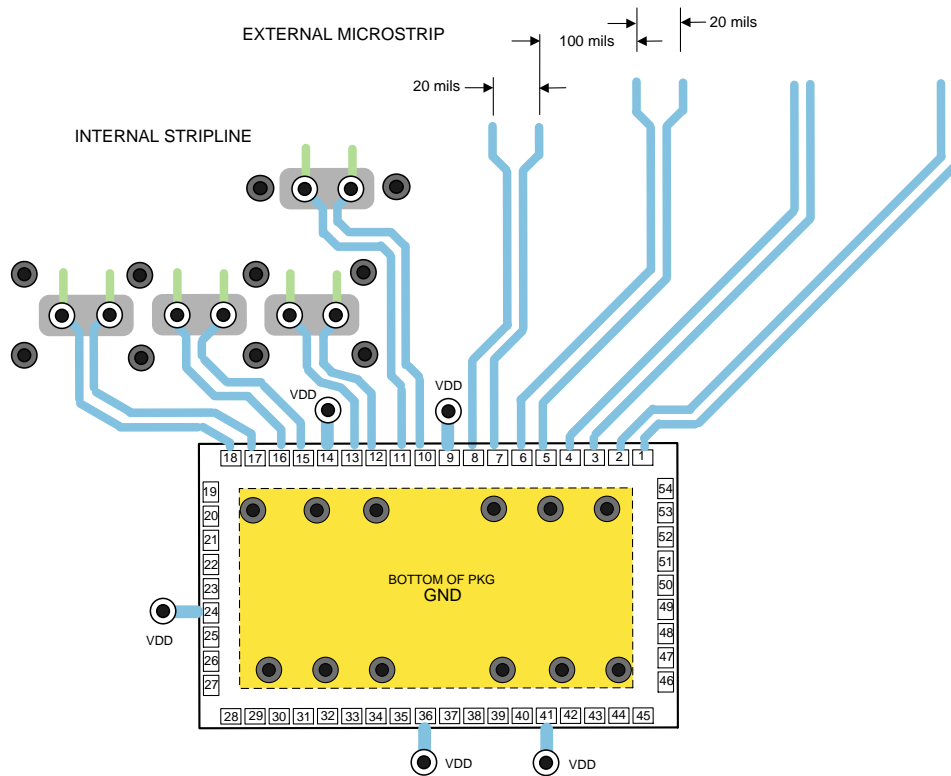

Figure 16. Typical Routing Options

11 Device and Documentation Support

11.1 Documentation Support

11.1.1 Related Documentation

For related documentation, see the following:

- *Absolute Maximum Ratings for Soldering* ([SNOA549](#))
- *Understanding EEPROM Programming for High Speed Repeaters and Mux Buffers* ([SNLA228](#))
- *AN-1187 Leadless Leadframe Package (LLP) Application Report* ([SNOA401](#))

11.2 Community Resources

The following links connect to TI community resources. Linked contents are provided "AS IS" by the respective contributors. They do not constitute TI specifications and do not necessarily reflect TI's views; see TI's [Terms of Use](#).

TI E2E™ Online Community *TI's Engineer-to-Engineer (E2E) Community*. Created to foster collaboration among engineers. At e2e.ti.com, you can ask questions, share knowledge, explore ideas and help solve problems with fellow engineers.

Design Support *TI's Design Support* Quickly find helpful E2E forums along with design support tools and contact information for technical support.

11.3 Trademarks

E2E is a trademark of Texas Instruments.
All other trademarks are the property of their respective owners.

11.4 Electrostatic Discharge Caution



These devices have limited built-in ESD protection. The leads should be shorted together or the device placed in conductive foam during storage or handling to prevent electrostatic damage to the MOS gates.

11.5 Glossary

[SLYZ022](#) — *TI Glossary*.

This glossary lists and explains terms, acronyms, and definitions.

12 Mechanical, Packaging, and Orderable Information

The following pages include mechanical, packaging, and orderable information. This information is the most current data available for the designated devices. This data is subject to change without notice and revision of this document. For browser-based versions of this data sheet, refer to the left-hand navigation.

PACKAGING INFORMATION

Orderable Device	Status (1)	Package Type	Package Drawing	Pins	Package Qty	Eco Plan (2)	Lead finish/ Ball material (6)	MSL Peak Temp (3)	Op Temp (°C)	Device Marking (4/5)	Samples
DS100MB203SQ/NOPB	ACTIVE	WQFN	NJY	54	2000	RoHS & Green	SN	Level-2-260C-1 YEAR	-40 to 85	DS100MB203	Samples
DS100MB203SQE/NOPB	ACTIVE	WQFN	NJY	54	250	RoHS & Green	SN	Level-2-260C-1 YEAR	-40 to 85	DS100MB203	Samples

(1) The marketing status values are defined as follows:

ACTIVE: Product device recommended for new designs.

LIFEBUY: TI has announced that the device will be discontinued, and a lifetime-buy period is in effect.

NRND: Not recommended for new designs. Device is in production to support existing customers, but TI does not recommend using this part in a new design.

PREVIEW: Device has been announced but is not in production. Samples may or may not be available.

OBSOLETE: TI has discontinued the production of the device.

(2) **RoHS:** TI defines "RoHS" to mean semiconductor products that are compliant with the current EU RoHS requirements for all 10 RoHS substances, including the requirement that RoHS substance do not exceed 0.1% by weight in homogeneous materials. Where designed to be soldered at high temperatures, "RoHS" products are suitable for use in specified lead-free processes. TI may reference these types of products as "Pb-Free".

RoHS Exempt: TI defines "RoHS Exempt" to mean products that contain lead but are compliant with EU RoHS pursuant to a specific EU RoHS exemption.

Green: TI defines "Green" to mean the content of Chlorine (Cl) and Bromine (Br) based flame retardants meet JS709B low halogen requirements of <=1000ppm threshold. Antimony trioxide based flame retardants must also meet the <=1000ppm threshold requirement.

(3) MSL, Peak Temp. - The Moisture Sensitivity Level rating according to the JEDEC industry standard classifications, and peak solder temperature.

(4) There may be additional marking, which relates to the logo, the lot trace code information, or the environmental category on the device.

(5) Multiple Device Markings will be inside parentheses. Only one Device Marking contained in parentheses and separated by a "~" will appear on a device. If a line is indented then it is a continuation of the previous line and the two combined represent the entire Device Marking for that device.

(6) Lead finish/Ball material - Orderable Devices may have multiple material finish options. Finish options are separated by a vertical ruled line. Lead finish/Ball material values may wrap to two lines if the finish value exceeds the maximum column width.

Important Information and Disclaimer:The information provided on this page represents TI's knowledge and belief as of the date that it is provided. TI bases its knowledge and belief on information provided by third parties, and makes no representation or warranty as to the accuracy of such information. Efforts are underway to better integrate information from third parties. TI has taken and continues to take reasonable steps to provide representative and accurate information but may not have conducted destructive testing or chemical analysis on incoming materials and chemicals. TI and TI suppliers consider certain information to be proprietary, and thus CAS numbers and other limited information may not be available for release.

In no event shall TI's liability arising out of such information exceed the total purchase price of the TI part(s) at issue in this document sold by TI to Customer on an annual basis.

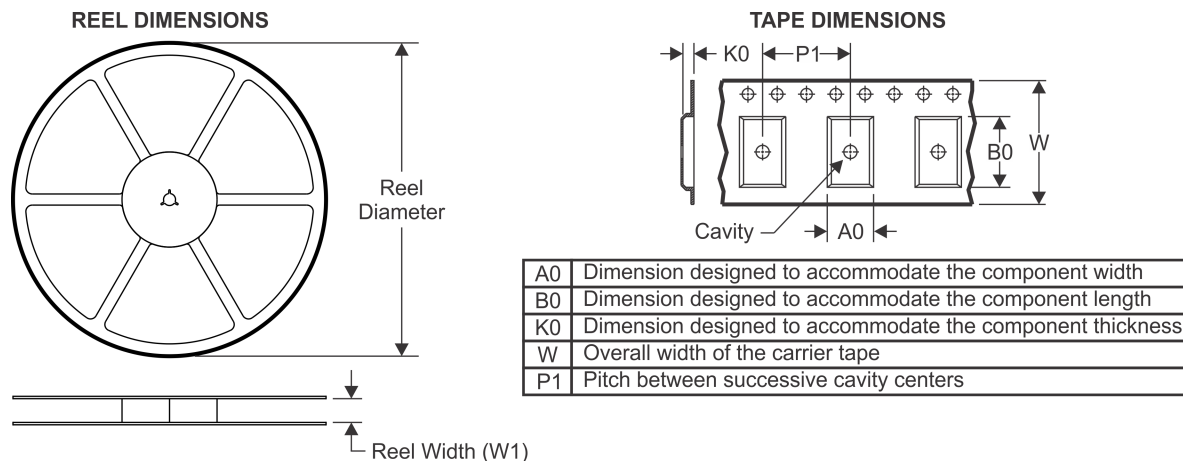
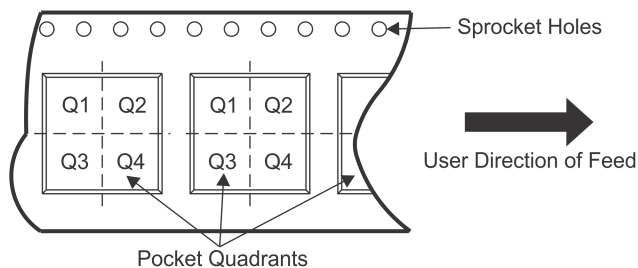
TAPE AND REEL INFORMATION

QUADRANT ASSIGNMENTS FOR PIN 1 ORIENTATION IN TAPE

*All dimensions are nominal

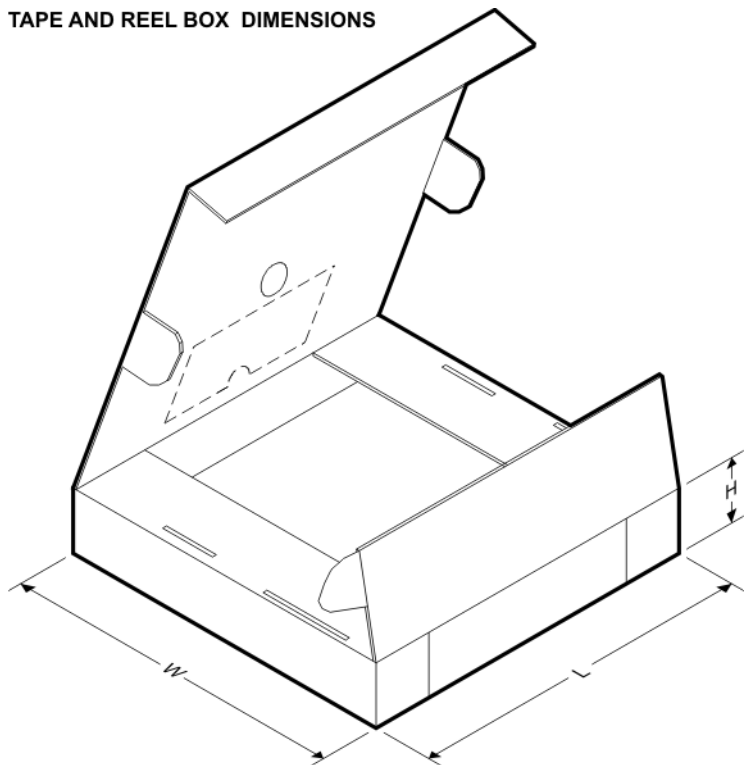
Device	Package Type	Package Drawing	Pins	SPQ	Reel Diameter (mm)	Reel Width W1 (mm)	A0 (mm)	B0 (mm)	K0 (mm)	P1 (mm)	W (mm)	Pin1 Quadrant
DS100MB203SQ/NOPB	WQFN	NJY	54	2000	330.0	16.4	5.8	10.3	1.0	12.0	16.0	Q1
DS100MB203SQE/NOPB	WQFN	NJY	54	250	178.0	16.4	5.8	10.3	1.0	12.0	16.0	Q1

TAPE AND REEL BOX DIMENSIONS

*All dimensions are nominal

Device	Package Type	Package Drawing	Pins	SPQ	Length (mm)	Width (mm)	Height (mm)
DS100MB203SQ/NOPB	WQFN	NJY	54	2000	853.0	449.0	35.0
DS100MB203SQE/NOPB	WQFN	NJY	54	250	208.0	191.0	35.0

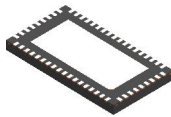

NJY0054A

WQFN

WQFN

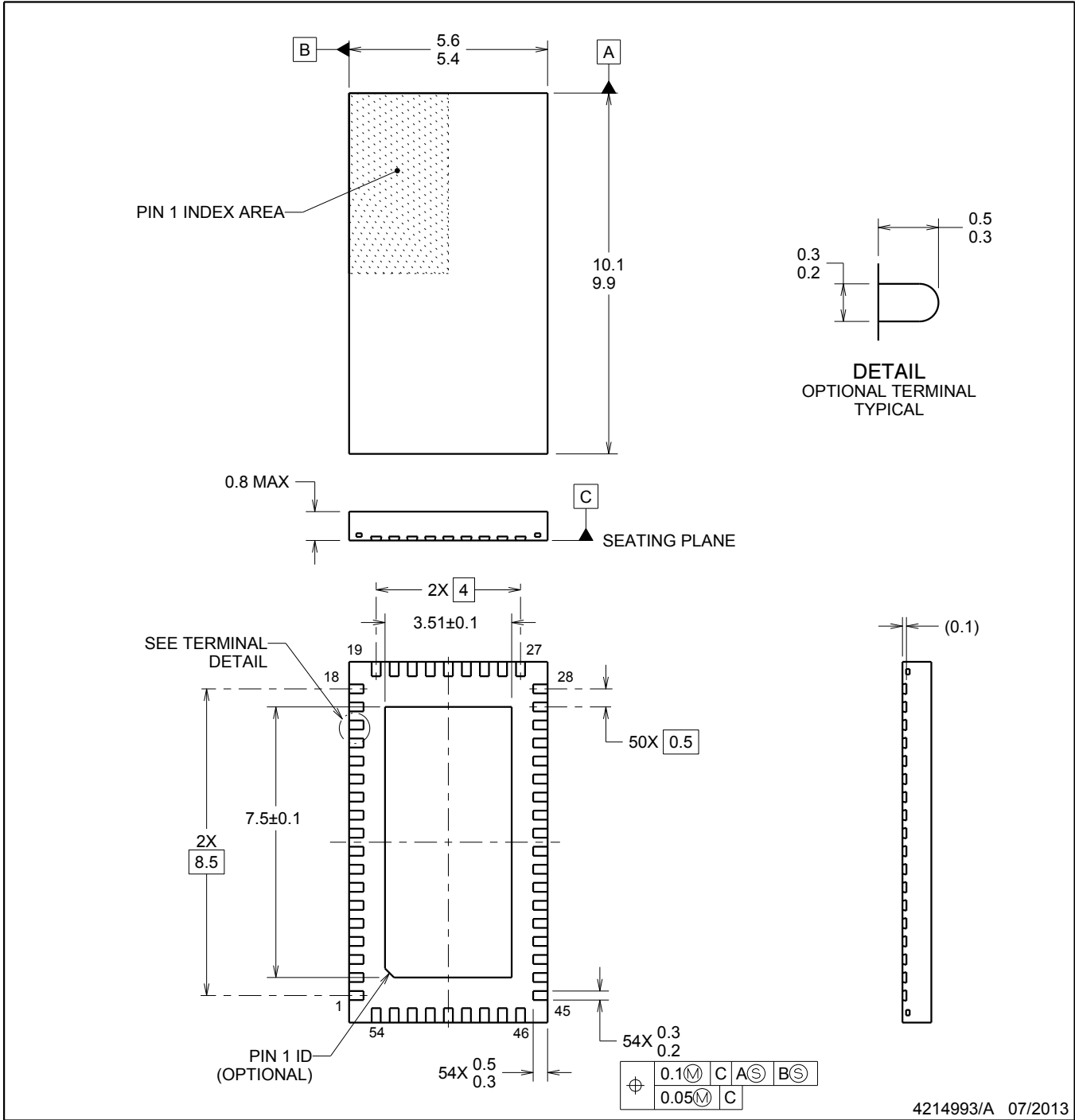

4214993/A 07/2013

NOTES:

1. All linear dimensions are in millimeters. Dimensions in parenthesis are for reference only. Dimensioning and tolerancing per ASME Y14.5M.
2. This drawing is subject to change without notice.
3. The package thermal pad must be soldered to the printed circuit board for thermal and mechanical performance.

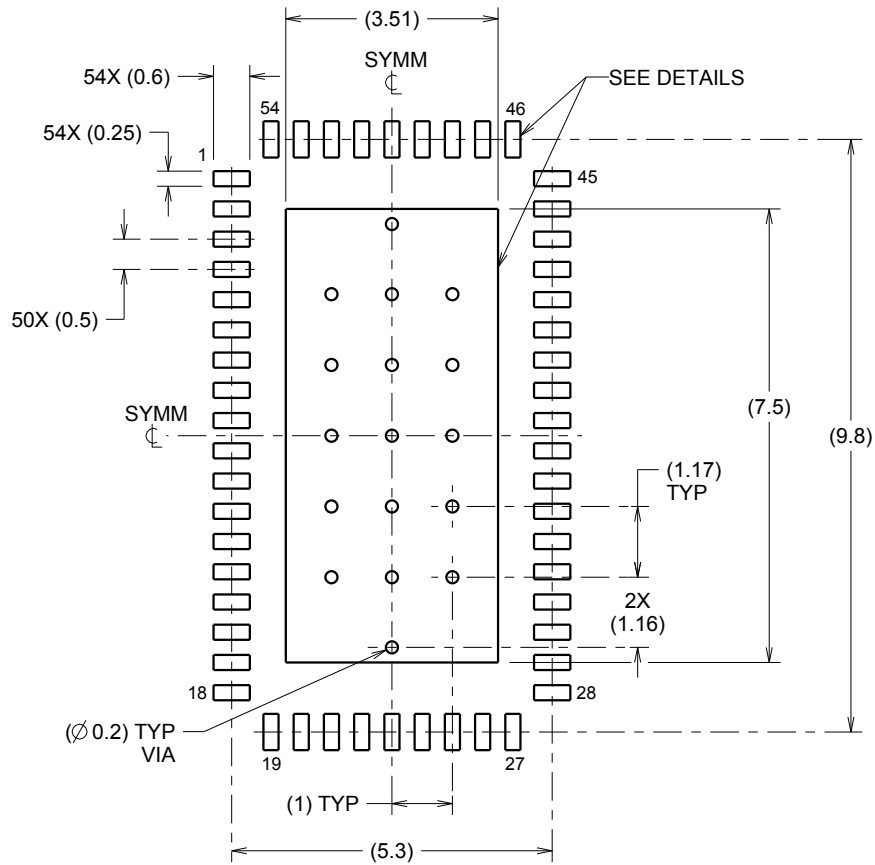

LAND PATTERN EXAMPLE
SCALE:8X

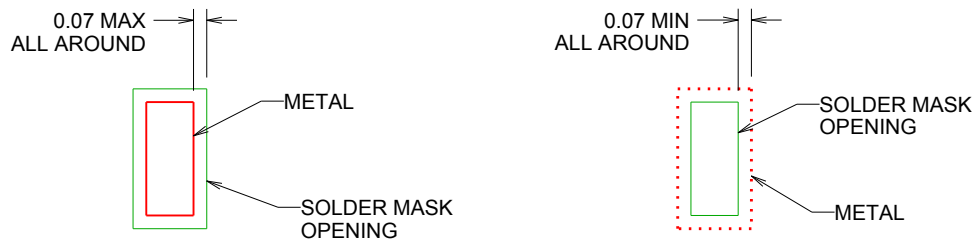

SOLDER MASK DETAILS

4214993/A 07/2013

NOTES: (continued)

- This package is designed to be soldered to a thermal pad on the board. For more information, refer to QFN/SON PCB application note in literature No. SLUA271 (www.ti.com/lit/slua271).

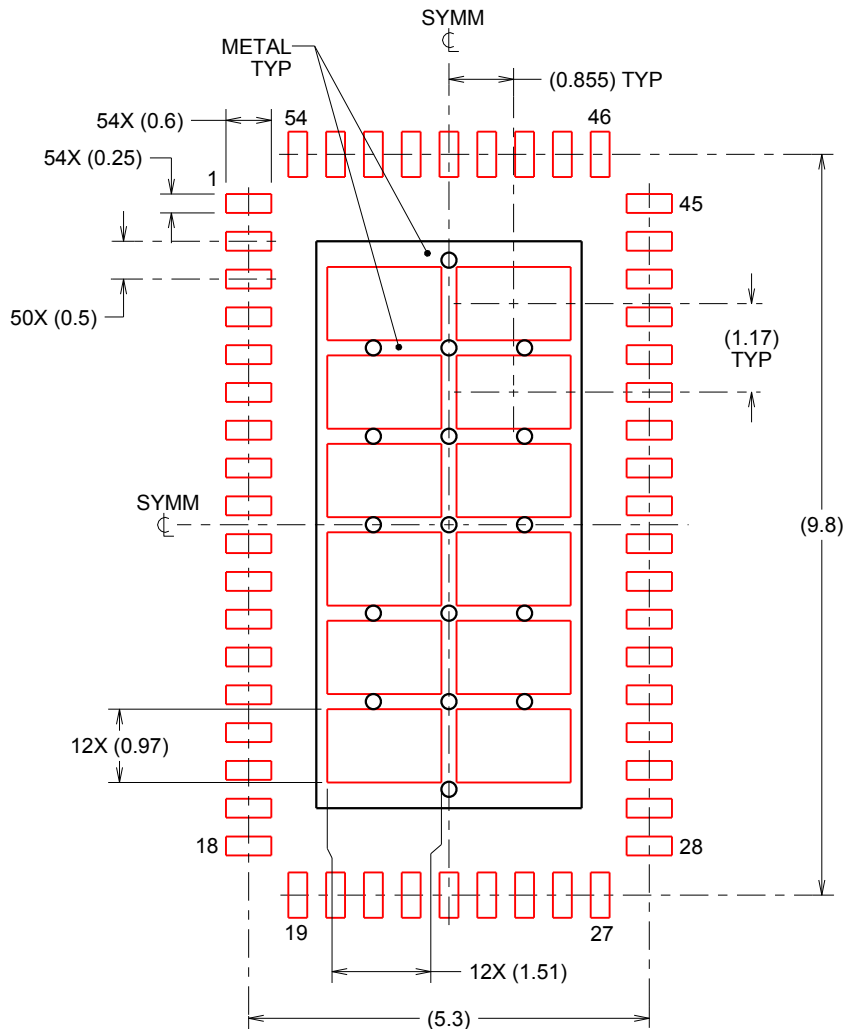

SOLDERPASTE EXAMPLE
 BASED ON 0.125mm THICK STENCIL

EXPOSED PAD
 67% PRINTED SOLDER COVERAGE BY AREA
 SCALE:10X

4214993/A 07/2013

NOTES: (continued)

5. Laser cutting apertures with trapezoidal walls and rounded corners may offer better paste release. IPC-7525 may have alternate design recommendations.

IMPORTANT NOTICE AND DISCLAIMER

TI PROVIDES TECHNICAL AND RELIABILITY DATA (INCLUDING DATA SHEETS), DESIGN RESOURCES (INCLUDING REFERENCE DESIGNS), APPLICATION OR OTHER DESIGN ADVICE, WEB TOOLS, SAFETY INFORMATION, AND OTHER RESOURCES "AS IS" AND WITH ALL FAULTS, AND DISCLAIMS ALL WARRANTIES, EXPRESS AND IMPLIED, INCLUDING WITHOUT LIMITATION ANY IMPLIED WARRANTIES OF MERCHANTABILITY, FITNESS FOR A PARTICULAR PURPOSE OR NON-INFRINGEMENT OF THIRD PARTY INTELLECTUAL PROPERTY RIGHTS.

These resources are intended for skilled developers designing with TI products. You are solely responsible for (1) selecting the appropriate TI products for your application, (2) designing, validating and testing your application, and (3) ensuring your application meets applicable standards, and any other safety, security, regulatory or other requirements.

These resources are subject to change without notice. TI grants you permission to use these resources only for development of an application that uses the TI products described in the resource. Other reproduction and display of these resources is prohibited. No license is granted to any other TI intellectual property right or to any third party intellectual property right. TI disclaims responsibility for, and you will fully indemnify TI and its representatives against, any claims, damages, costs, losses, and liabilities arising out of your use of these resources.

TI's products are provided subject to [TI's Terms of Sale](#) or other applicable terms available either on ti.com or provided in conjunction with such TI products. TI's provision of these resources does not expand or otherwise alter TI's applicable warranties or warranty disclaimers for TI products.

TI objects to and rejects any additional or different terms you may have proposed.

Mailing Address: Texas Instruments, Post Office Box 655303, Dallas, Texas 75265
Copyright © 2021, Texas Instruments Incorporated