



Low-Noise, Low-Distortion INSTRUMENTATION AMPLIFIER

FEATURES

- **LOW NOISE:** $1\text{nV}/\sqrt{\text{Hz}}$ at 1kHz
- **LOW THD+N:** 0.002% at 1kHz, $G = 100$
- **WIDE BANDWIDTH:** 800kHz at $G = 100$
- **WIDE SUPPLY RANGE:** $\pm 4.5\text{V}$ to $\pm 18\text{V}$
- **HIGH CMR:** $> 100\text{dB}$
- **GAIN SET WITH EXTERNAL RESISTOR**
- **SO-14 SURFACE-MOUNT PACKAGE**

APPLICATIONS

- PROFESSIONAL MICROPHONE PREAMPS
- MOVING-COIL TRANSDUCER AMPLIFIERS
- DIFFERENTIAL RECEIVERS
- BRIDGE TRANSDUCER AMPLIFIERS

DESCRIPTION

The INA163 is a very low-noise, low-distortion, monolithic instrumentation amplifier. Its current-feedback circuitry achieves very wide bandwidth and excellent dynamic response over a wide range of gain. It is ideal for low-level audio signals such as balanced low-impedance microphones. Many industrial, instrumentation, and medical applications also benefit from its low noise and wide bandwidth.

Unique distortion cancellation circuitry reduces distortion to extremely low levels, even in high gain. The INA163 provides near-theoretical noise performance for 200Ω source impedance. Its differential input, low noise, and low distortion provide superior performance in professional microphone amplifier applications.

The INA163's wide supply voltage, excellent output voltage swing, and high output current drive allow its use in high-level audio stages as well.

The INA163 is available in a space-saving SO-14 surface-mount package, specified for operation over the -40°C to $+85^\circ\text{C}$ temperature range.

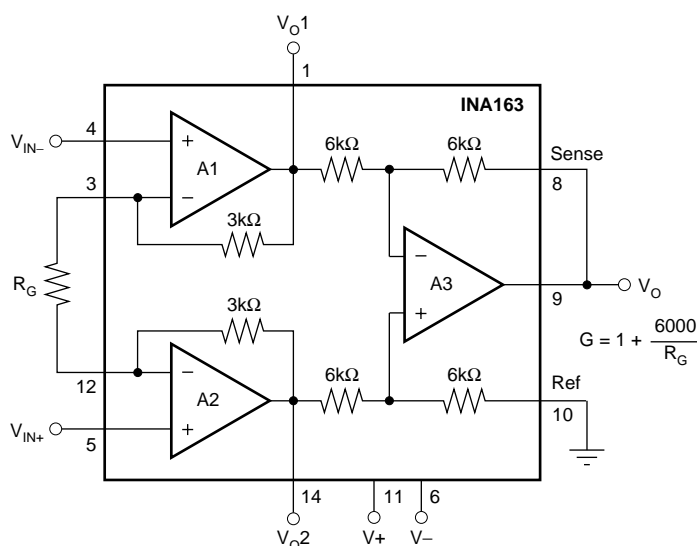

Please be aware that an important notice concerning availability, standard warranty, and use in critical applications of Texas Instruments semiconductor products and disclaimers thereto appears at the end of this data sheet.

All trademarks are the property of their respective owners.

PIN CONFIGURATION

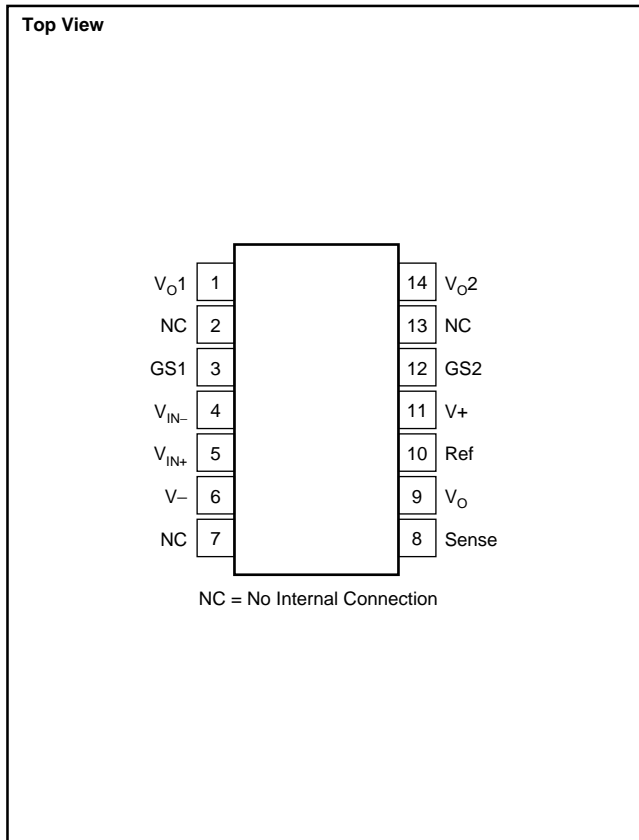

ELECTROSTATIC DISCHARGE SENSITIVITY

This integrated circuit can be damaged by ESD. Texas Instruments recommends that all integrated circuits be handled with appropriate precautions. Failure to observe proper handling and installation procedures can cause damage.

ESD damage can range from subtle performance degradation to complete device failure. Precision integrated circuits may be more susceptible to damage because very small parametric changes could cause the device not to meet its published specifications.

ABSOLUTE MAXIMUM RATINGS⁽¹⁾

Power Supply Voltage	±18V
Signal Input Terminals, Voltage ⁽²⁾	(V ₋) - 0.5V to (V ₊) + 0.5V
Current ⁽²⁾	10mA
Output Short-Circuit to Ground	Continuous
Operating Temperature	-55°C to +125°C
Storage Temperature	-55°C to +125°C
Junction Temperature	+150°C
Lead Temperature (soldering, 10s)	+300°C

NOTES: (1) Stresses above these ratings may cause permanent damage. Exposure to absolute maximum conditions for extended periods may degrade device reliability. These are stress ratings only, and functional operation of the device at these or any other conditions beyond those specified is not implied. (2) Input terminals are diode-clamped to the power-supply rails. Input signals that can swing more than 0.5V beyond the supply rails should be current limited to 10mA or less.

PACKAGE/ORDERING INFORMATION⁽¹⁾

PRODUCT	PACKAGE-LEAD	DESIGNATOR	MARKING
INA163UA	SO-14 Surface Mount	D	INA163UA

NOTE: (1) For the most current package and ordering information, see the Package Option Addendum located at the end of this document, or see the TI web site at www.ti.com.

TYPICAL CHARACTERISTICS

At $T_A = +25^\circ\text{C}$, $V_S = 5\text{V}$, $V_{CM} = 1/2 V_S$, $R_L = 25\text{k}\Omega$, $C_L = 50\text{pF}$, unless otherwise noted.

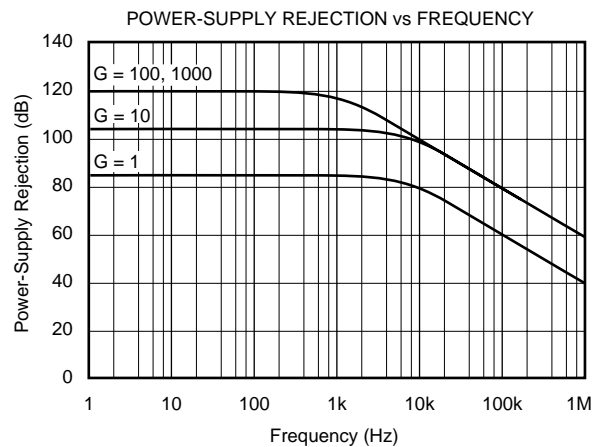
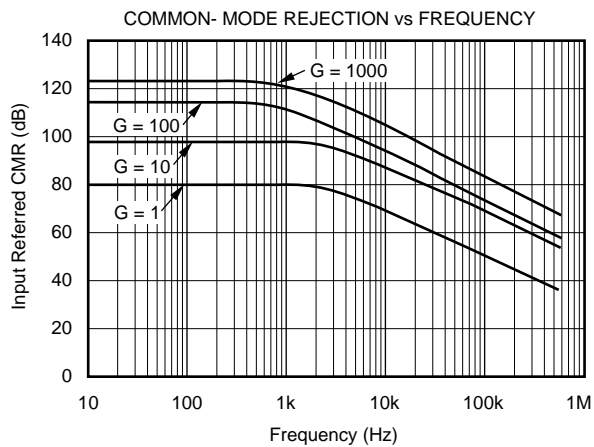
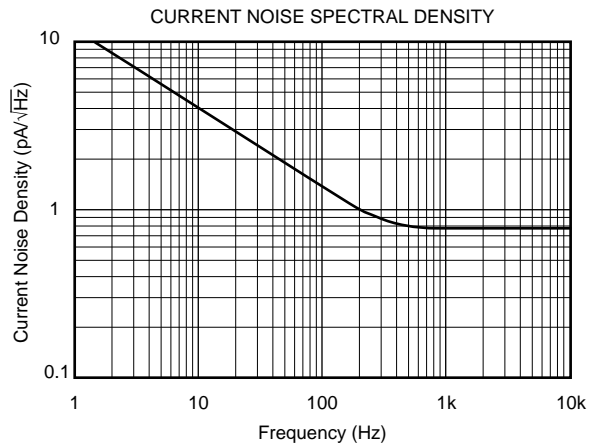
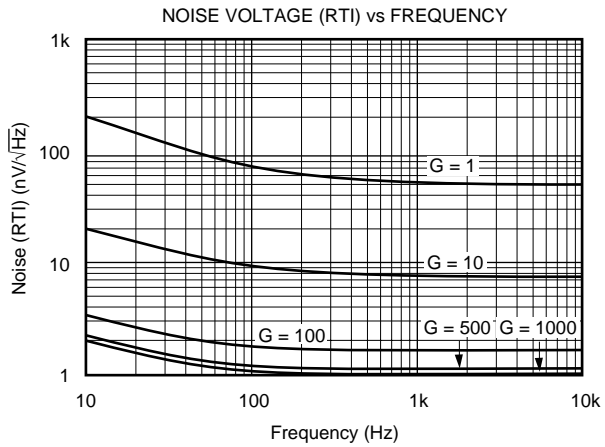
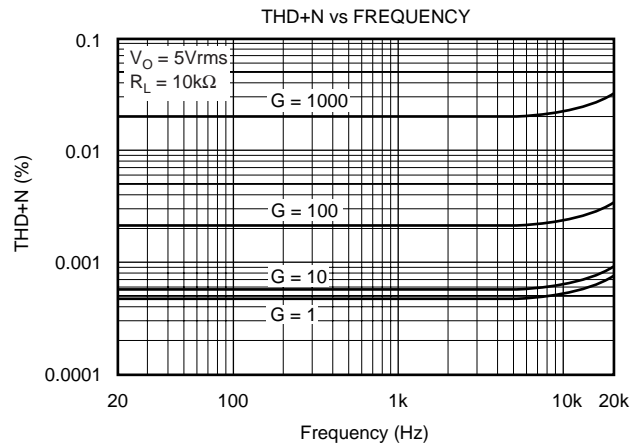
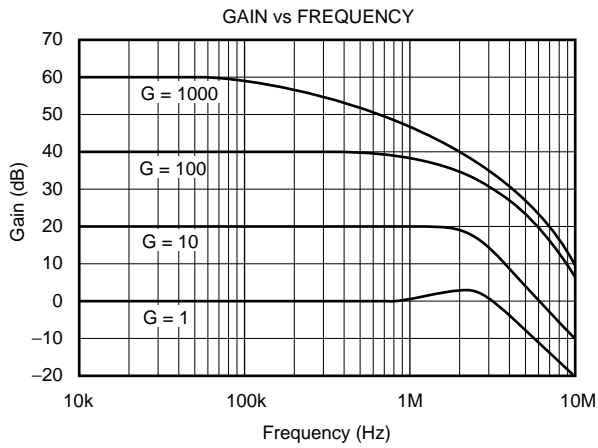

TYPICAL CHARACTERISTICS (Cont.)

At $T_A = +25^\circ\text{C}$, $V_S = 5\text{V}$, $V_{CM} = 1/2V_S$, $R_L = 25\text{k}\Omega$, $C_L = 50\text{pF}$, unless otherwise noted.

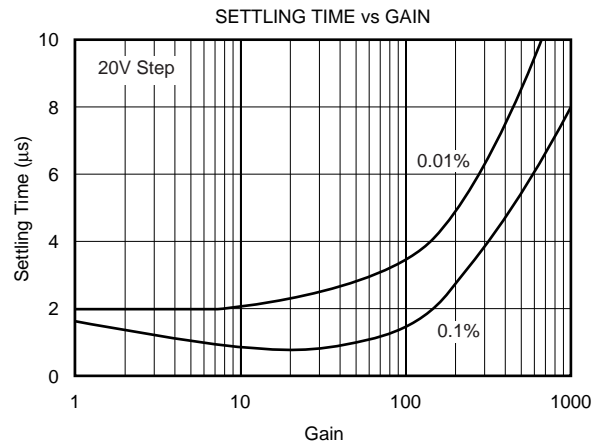
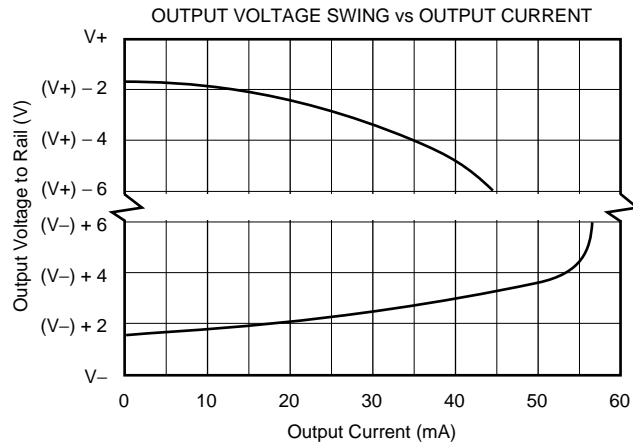

SMALL-SIGNAL TRANSIENT RESPONSE
(G = 1)

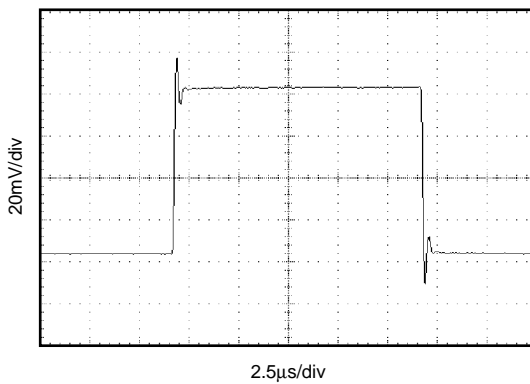

SMALL-SIGNAL TRANSIENT RESPONSE
(G = 100)

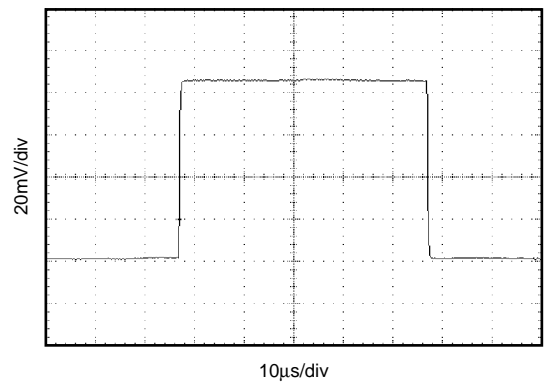

LARGE-SIGNAL TRANSIENT RESPONSE
(G = 1)

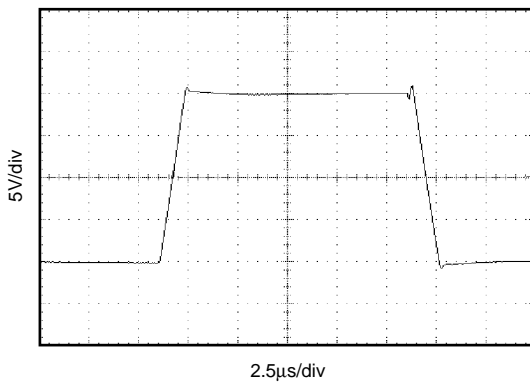

LARGE-SIGNAL TRANSIENT RESPONSE
(G = 100)

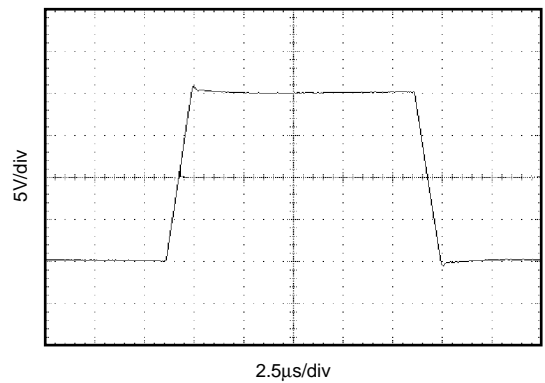

APPLICATIONS INFORMATION

Figure 1 shows the basic connections required for operation. Power supplies should be bypassed with 0.1µF tantalum capacitors near the device pins. The output Sense (pin 8) and output Reference (pin 10) should be low-impedance connections. Resistance of a few ohms in series with these connections will degrade the common-mode rejection of the INA163.

GAIN-SET RESISTOR

Gain is set with an external resistor, R_G , as shown in Figure 1. The two internal 3kΩ feedback resistors are laser-trimmed to 3kΩ within approximately ±0.2%. Gain is:

$$G = 1 + \frac{6000}{R_G}$$

The temperature coefficient of the internal 3kΩ resistors is approximately ±25ppm/°C. Accuracy and TCR of the external R_G will also contribute to gain error and

temperature drift. These effects can be inferred from the gain equation. Make a short, direct connection to the gain set resistor, R_G . Avoid running output signals near these sensitive input nodes.

NOISE PERFORMANCE

The INA163 provides very low-noise with low-source impedance. Its 1nV/√Hz voltage noise delivers near-theoretical noise performance with a source impedance of 200Ω. The input stage design used to achieve this low noise, results in relatively high input bias current and input bias current noise. As a result, the INA163 may not provide the best noise performance with a source impedance greater than 10kΩ. For source impedance greater than 10kΩ, other instrumentation amplifiers may provide improved noise performance.

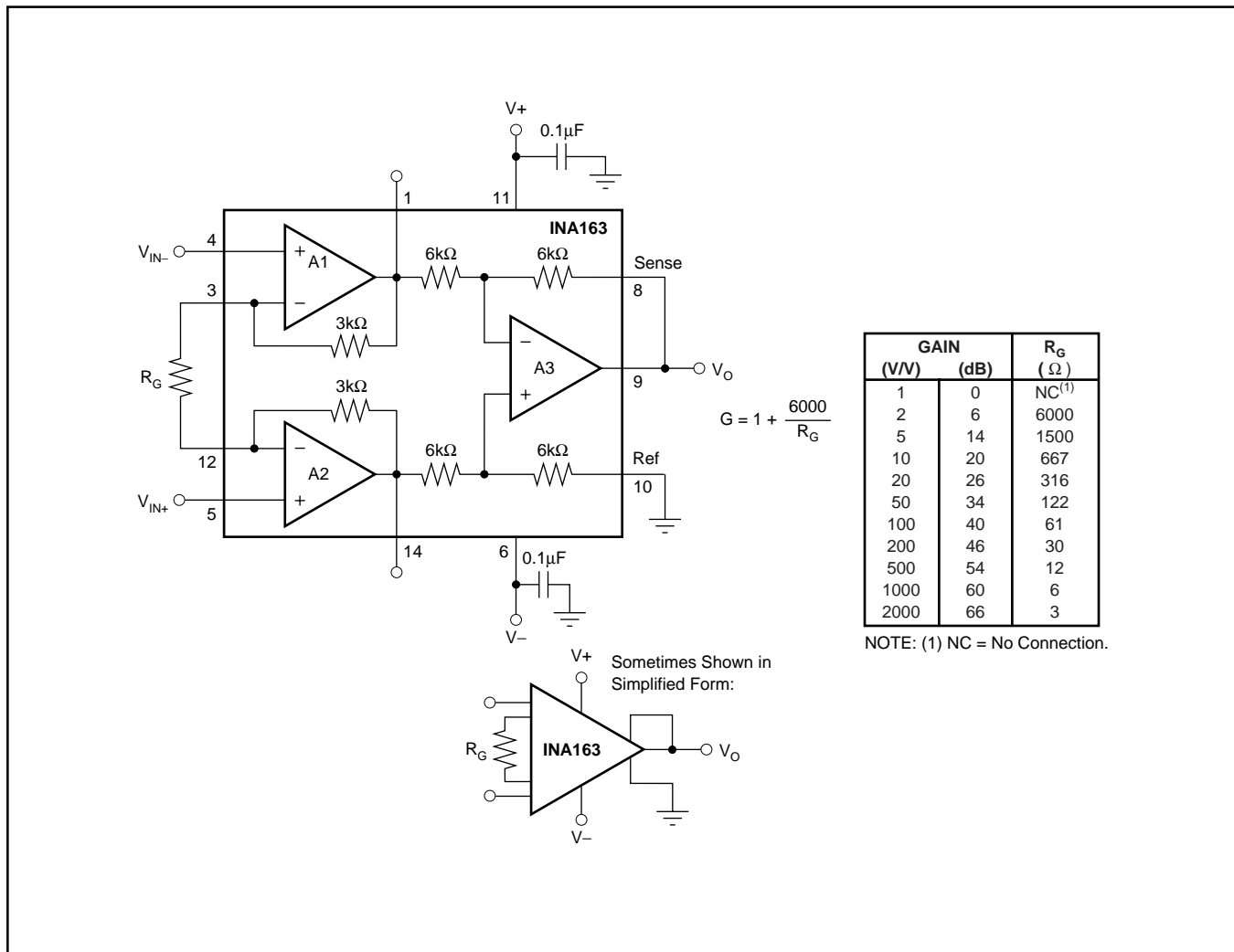

FIGURE 1. Basic Circuit Connections.

PACKAGING INFORMATION

Orderable Device	Status (1)	Package Type	Package Drawing	Pins	Package Qty	Eco Plan (2)	Lead finish/ Ball material (6)	MSL Peak Temp (3)	Op Temp (°C)	Device Marking (4/5)	Samples
INA163UA	ACTIVE	SOIC	D	14	50	RoHS & Green	NIPDAU	Level-3-260C-168 HR	-40 to 85	INA163UA	Samples
INA163UA/2K5	ACTIVE	SOIC	D	14	2500	RoHS & Green	NIPDAU	Level-3-260C-168 HR	-40 to 85	INA163UA	Samples
INA163UA/2K5E4	ACTIVE	SOIC	D	14	2500	RoHS & Green	NIPDAU	Level-3-260C-168 HR	-40 to 85	INA163UA	Samples
INA163UAE4	ACTIVE	SOIC	D	14	50	RoHS & Green	NIPDAU	Level-3-260C-168 HR	-40 to 85	INA163UA	Samples

(1) The marketing status values are defined as follows:

ACTIVE: Product device recommended for new designs.

LIFEBUY: TI has announced that the device will be discontinued, and a lifetime-buy period is in effect.

NRND: Not recommended for new designs. Device is in production to support existing customers, but TI does not recommend using this part in a new design.

PREVIEW: Device has been announced but is not in production. Samples may or may not be available.

OBSOLETE: TI has discontinued the production of the device.

(2) **RoHS:** TI defines "RoHS" to mean semiconductor products that are compliant with the current EU RoHS requirements for all 10 RoHS substances, including the requirement that RoHS substance do not exceed 0.1% by weight in homogeneous materials. Where designed to be soldered at high temperatures, "RoHS" products are suitable for use in specified lead-free processes. TI may reference these types of products as "Pb-Free".

RoHS Exempt: TI defines "RoHS Exempt" to mean products that contain lead but are compliant with EU RoHS pursuant to a specific EU RoHS exemption.

Green: TI defines "Green" to mean the content of Chlorine (Cl) and Bromine (Br) based flame retardants meet JS709B low halogen requirements of <=1000ppm threshold. Antimony trioxide based flame retardants must also meet the <=1000ppm threshold requirement.

(3) **MSL, Peak Temp.** - The Moisture Sensitivity Level rating according to the JEDEC industry standard classifications, and peak solder temperature.

(4) There may be additional marking, which relates to the logo, the lot trace code information, or the environmental category on the device.

(5) Multiple Device Markings will be inside parentheses. Only one Device Marking contained in parentheses and separated by a "-" will appear on a device. If a line is indented then it is a continuation of the previous line and the two combined represent the entire Device Marking for that device.

(6) **Lead finish/Ball material** - Orderable Devices may have multiple material finish options. Finish options are separated by a vertical ruled line. Lead finish/Ball material values may wrap to two lines if the finish value exceeds the maximum column width.

Important Information and Disclaimer: The information provided on this page represents TI's knowledge and belief as of the date that it is provided. TI bases its knowledge and belief on information provided by third parties, and makes no representation or warranty as to the accuracy of such information. Efforts are underway to better integrate information from third parties. TI has taken and

continues to take reasonable steps to provide representative and accurate information but may not have conducted destructive testing or chemical analysis on incoming materials and chemicals. TI and TI suppliers consider certain information to be proprietary, and thus CAS numbers and other limited information may not be available for release.

In no event shall TI's liability arising out of such information exceed the total purchase price of the TI part(s) at issue in this document sold by TI to Customer on an annual basis.

TAPE AND REEL INFORMATION

QUADRANT ASSIGNMENTS FOR PIN 1 ORIENTATION IN TAPE

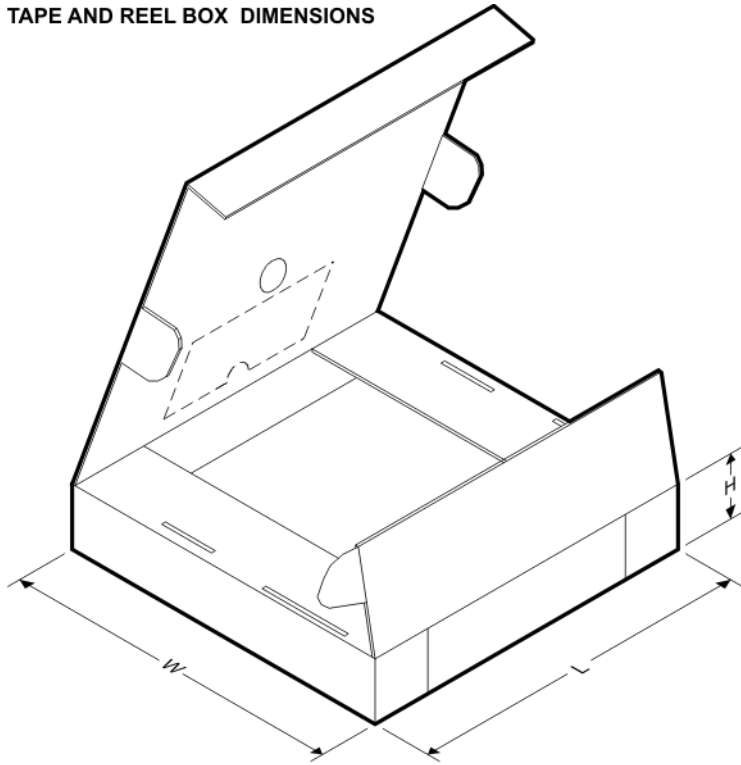

*All dimensions are nominal

Device	Package Type	Package Drawing	Pins	SPQ	Reel Diameter (mm)	Reel Width W1 (mm)	A0 (mm)	B0 (mm)	K0 (mm)	P1 (mm)	W (mm)	Pin1 Quadrant
INA163UA/2K5	SOIC	D	14	2500	330.0	16.4	6.5	9.0	2.1	8.0	16.0	Q1

TAPE AND REEL BOX DIMENSIONS

*All dimensions are nominal

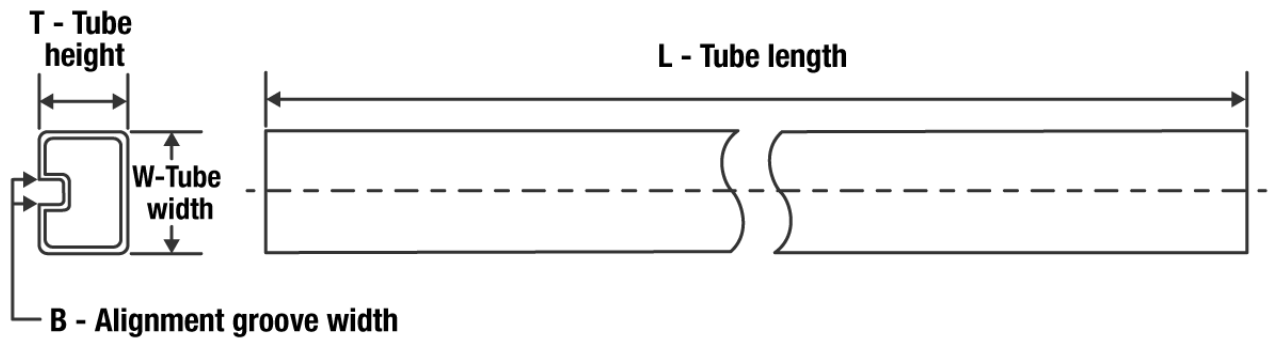
Device	Package Type	Package Drawing	Pins	SPQ	Length (mm)	Width (mm)	Height (mm)
INA163UA/2K5	SOIC	D	14	2500	853.0	449.0	35.0

TUBE

*All dimensions are nominal

Device	Package Name	Package Type	Pins	SPQ	L (mm)	W (mm)	T (μm)	B (mm)
INA163UA	D	SOIC	14	50	506.6	8	3940	4.32
INA163UAE4	D	SOIC	14	50	506.6	8	3940	4.32

D (R-PDSO-G14)

PLASTIC SMALL OUTLINE



- NOTES:
- A. All linear dimensions are in inches (millimeters).
 - B. This drawing is subject to change without notice.
 -  Body length does not include mold flash, protrusions, or gate burrs. Mold flash, protrusions, or gate burrs shall not exceed 0.006 (0,15) each side.
 -  Body width does not include interlead flash. Interlead flash shall not exceed 0.017 (0,43) each side.
 - E. Reference JEDEC MS-012 variation AB.

D (R-PDSO-G14)

PLASTIC SMALL OUTLINE

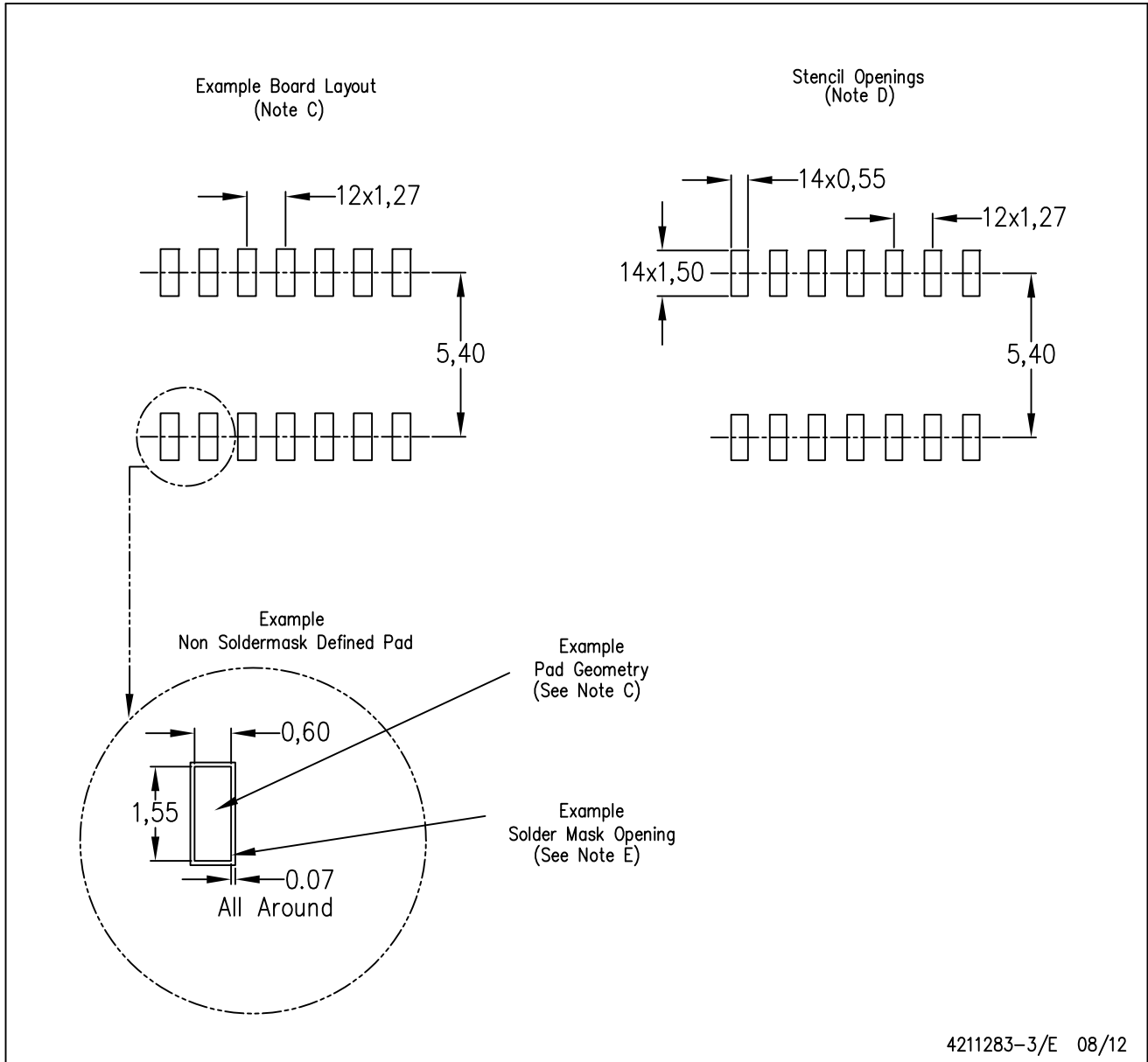

- NOTES:
- All linear dimensions are in millimeters.
 - This drawing is subject to change without notice.
 - Publication IPC-7351 is recommended for alternate designs.
 - Laser cutting apertures with trapezoidal walls and also rounding corners will offer better paste release. Customers should contact their board assembly site for stencil design recommendations. Refer to IPC-7525 for other stencil recommendations.
 - Customers should contact their board fabrication site for solder mask tolerances between and around signal pads.

IMPORTANT NOTICE AND DISCLAIMER

TI PROVIDES TECHNICAL AND RELIABILITY DATA (INCLUDING DATA SHEETS), DESIGN RESOURCES (INCLUDING REFERENCE DESIGNS), APPLICATION OR OTHER DESIGN ADVICE, WEB TOOLS, SAFETY INFORMATION, AND OTHER RESOURCES "AS IS" AND WITH ALL FAULTS, AND DISCLAIMS ALL WARRANTIES, EXPRESS AND IMPLIED, INCLUDING WITHOUT LIMITATION ANY IMPLIED WARRANTIES OF MERCHANTABILITY, FITNESS FOR A PARTICULAR PURPOSE OR NON-INFRINGEMENT OF THIRD PARTY INTELLECTUAL PROPERTY RIGHTS.

These resources are intended for skilled developers designing with TI products. You are solely responsible for (1) selecting the appropriate TI products for your application, (2) designing, validating and testing your application, and (3) ensuring your application meets applicable standards, and any other safety, security, regulatory or other requirements.

These resources are subject to change without notice. TI grants you permission to use these resources only for development of an application that uses the TI products described in the resource. Other reproduction and display of these resources is prohibited. No license is granted to any other TI intellectual property right or to any third party intellectual property right. TI disclaims responsibility for, and you will fully indemnify TI and its representatives against, any claims, damages, costs, losses, and liabilities arising out of your use of these resources.

TI's products are provided subject to [TI's Terms of Sale](#) or other applicable terms available either on ti.com or provided in conjunction with such TI products. TI's provision of these resources does not expand or otherwise alter TI's applicable warranties or warranty disclaimers for TI products.

TI objects to and rejects any additional or different terms you may have proposed.

Mailing Address: Texas Instruments, Post Office Box 655303, Dallas, Texas 75265
Copyright © 2022, Texas Instruments Incorporated