

ISO5852S-Q1 具有分离输出和有源安全特性的高 CMTI 2.5A 和 5A 增强型 隔离式 IGBT、MOSFET 栅极 驱动器

1 特性

- 适用于汽车电子 应用
- 具有符合 AEC-Q100 标准的下列结果：
 - 器件温度 1 级：-40°C 至 125°C 的环境运行温度范围
 - 器件人体模型 (HBM) 分类等级 3A
 - 器件充电器件模型 (CDM) 分类等级 C6
- $V_{CM} = 1500V$ 时，共模瞬态抗扰度 (CMTI) 的最小值为 $100kV/\mu s$
- 分离输出，可提供 2.5A 峰值拉电流和 5A 峰值灌电流
- 短暂传播延迟：76ns（典型值），110ns（最大值）
- 2A 有源米勒钳位
- 输出短路钳位
- 短路期间的软关断 (STO)
- 在检测到去饱和和故障时通过 \overline{FLT} 发出故障报警，并通过 \overline{RST} 复位
- 具有就绪 (RDY) 引脚指示的输入和输出欠压锁定 (UVLO)
- 有源输出下拉特性，在低电源或输入悬空的情况下默认输出低电平
- 2.25V 至 5.5V 输入电源电压
- 15V 至 30V 输出驱动器电源电压
- 互补金属氧化物半导体 (CMOS) 兼容输入
- 抑制短于 20ns 的输入脉冲和瞬态噪声
- 可承受的浪涌隔离电压达 $12800V_{PK}$ ”
- 安全相关认证：
 - 符合 DIN V VDE V 0884-10 (VDE V 0884-10):2006-12 标准的 $8000 V_{PK} V_{IOTM}$ 和 $2121 V_{PK} V_{IORM}$ 增强型隔离
 - 符合 UL 1577 标准且长达 1 分钟的 $5700 V_{RMS}$ 隔离
 - CSA 组件验收通知 5A, IEC 60950-1 和 IEC 60601-1 终端设备标准
 - 符合 EN 61010-1 和 EN 60950-1 标准的 TUV 认证
 - GB4943.1-2011 CQC 认证
 - 已通过 UL、VDE、CQC、TUV 认证并规划进行 CSA 认证

2 应用

- 隔离式绝缘栅双极型晶体管 (IGBT) 和金属氧化物半导体场效应晶体管 (MOSFET) 驱动器：
 - 混合动力汽车 (HEV) 和电动车 (EV) 电源模块
 - 工业电机控制驱动
 - 工业电源
 - 太阳能逆变器
 - 感应加热

3 说明

ISO5852S-Q1 器件是一款用于 IGBT 和 MOSFET 的 5.7 kV_{RMS} 增强型隔离栅极驱动器，具有分离输出（OUTH 和 OUTL）以及 2.5A 的拉电流能力和 5A 的灌电流能力。输入端由 2.25V 至 5.5V 的单电源供电运行。输出端允许电源范围为 15V 至 30V。两个互补 CMOS 输入控制栅极驱动器的输出状态。76ns 的短暂传播时间保证了对于输出级的精确控制。中的文本由“3V 至 5.5V 单电源”更改为“2.25V 至 5.5V 单电源”中的文本由“IGBT 处于过载状态”更改为“IGBT 处于过流状态”

器件信息⁽¹⁾

器件型号	封装	封装尺寸（标称值）
ISO5852S-Q1	SOIC (16)	10.30mm x 7.50mm

(1) 要了解所有可用封装，请见数据表末尾的可订购产品附录。

功能方框图

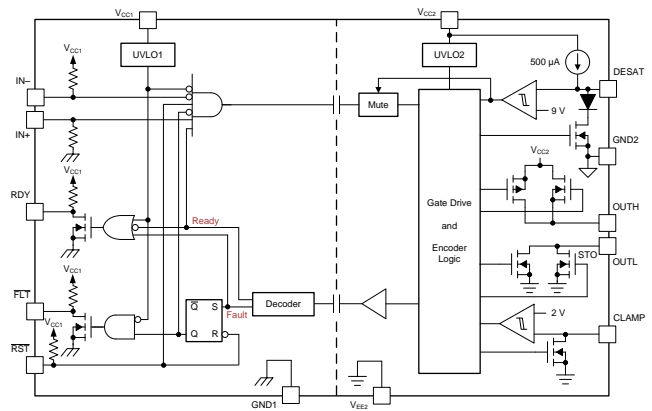

Copyright © 2016, Texas Instruments Incorporated



目录

<p>1 特性 1</p> <p>2 应用 1</p> <p>3 说明 1</p> <p>4 修订历史记录 2</p> <p>5 说明 (续) 3</p> <p>6 Pin Configuration and Function 3</p> <p>7 Specifications 4</p> <p> 7.1 Absolute Maximum Ratings 4</p> <p> 7.2 ESD Ratings 4</p> <p> 7.3 Recommended Operating Conditions 4</p> <p> 7.4 Thermal Information 5</p> <p> 7.5 Power Ratings 5</p> <p> 7.6 Insulation Specifications 6</p> <p> 7.7 Safety Limiting Values 7</p> <p> 7.8 Safety-Related Certifications 7</p> <p> 7.9 Electrical Characteristics 8</p> <p> 7.10 Switching Characteristics 9</p> <p> 7.11 Safety and Insulation Characteristics Curves 10</p> <p> 7.12 Typical Characteristics 11</p> <p>8 Parameter Measurement Information 18</p>	<p>9 Detailed Description 20</p> <p> 9.1 Overview 20</p> <p> 9.2 Functional Block Diagram 20</p> <p> 9.3 Feature Description 21</p> <p> 9.4 Device Functional Modes 22</p> <p>10 Application and Implementation 23</p> <p> 10.1 Application Information 23</p> <p> 10.2 Typical Applications 23</p> <p>11 Power Supply Recommendations 33</p> <p>12 Layout 33</p> <p> 12.1 Layout Guidelines 33</p> <p> 12.2 PCB Material 33</p> <p> 12.3 Layout Example 33</p> <p>13 器件和文档支持 34</p> <p> 13.1 文档支持 34</p> <p> 13.2 接收文档更新通知 34</p> <p> 13.3 社区资源 34</p> <p> 13.4 商标 34</p> <p> 13.5 静电放电警告 34</p> <p> 13.6 Glossary 34</p> <p>14 机械、封装和可订购信息 35</p>
---	--

4 修订历史记录

注：之前版本的页码可能与当前版本有所不同。

日期	修订版本	注释
2016 年 9 月	*	最初发布。

5 说明 (续)

内置的去饱和 (DESAT) 故障检测功能可识别 IGBT 何时处于过流状态。检测到 DESAT 时，静音逻辑会立即阻断隔离器输出，并启动软关断过程以禁用 OUTH 引脚并将 OUTL 引脚拉至低电平持续 2 μ s。当 OUTL 引脚达到 2V 时（相对于最大负电源电势 V_{EE2} ），栅极驱动器会被“硬”拉至 V_{EE2} 电势，从而立即将 IGBT 关断。已将中的文本由“并降低 OUTL 的电压持续 2 μ s 以上”更改为“并将 OUTL 拉至低电平持续 2 μ s”

当发生去饱和和故障时，器件会通过隔离栅发送故障信号，以将输入端的 \overline{FLT} 输出拉为低电平并阻断隔离器的输入。静音逻辑在软关断期间激活。 \overline{FLT} 的输出状态将被锁存，并只能在 RDY 引脚变为高电平后通过 \overline{RST} 输入上的低电平有效脉冲复位。已更改的第 3 段

如果在由双极输出电源供电的正常运行期间关断 IGBT，输出电压会被硬钳位为 V_{EE2} 。如果输出电源为单极，那么可采用有源米勒钳位，这种钳位会在一条低阻抗路径上灌入米勒电流，从而防止 IGBT 在高电压瞬态状态下发生动态导通。

栅极驱动器是否准备就绪待运行由两个欠压锁定电路控制，这两个电路会监视输入端和输出端的电源。如果任意一端电源不足，RDY 输出会变为低电平，否则该输出为高电平。

ISO5852S-Q1 采用 16 引脚小外形尺寸集成电路 (SOIC) 封装。此器件的额定工作环境温度范围为 -40°C 至 +125°C。

6 Pin Configuration and Function

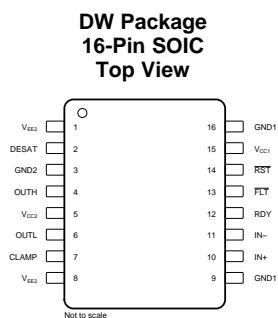

Pin Functions

PIN		I/O	DESCRIPTION
NAME	NO.		
CLAMP	7	O	Miller clamp output
DESAT	2	I	Desaturation voltage input
\overline{FLT}	13	O	Fault output, active-low during DESAT condition
GND1	9	—	Input ground
	16		
GND2	3	—	Gate drive common. Connect to IGBT emitter.
IN+	10	I	Non-inverting gate drive voltage control input
IN-	11	I	Inverting gate drive voltage control input
OUTH	4	O	Positive gate drive voltage output
OUTL	6	O	Negative gate drive voltage output
RDY	12	O	Power-good output, active high when both supplies are good.
\overline{RST}	14	I	Reset input, apply a low pulse to reset fault latch.
V_{CC1}	15	—	Positive input supply (2.25-V to 5.5-V)
V_{CC2}	5	—	Most positive output supply potential.
V_{EE2}	1	—	Output negative supply. Connect to GND2 for unipolar supply application.
	8		

7 Specifications

7.1 Absolute Maximum Ratings

Over operating free-air temperature range (unless otherwise noted)⁽¹⁾

		MIN	MAX	UNIT	
V _{CC1}	Supply-voltage input side	GND1 – 0.3	6	V	
V _{CC2}	Positive supply-voltage output side	(V _{CC2} – GND2)	–0.3	35	V
V _{EE2}	Negative supply-voltage output side	(V _{EE2} – GND2)	–17.5	0.3	V
V _(SUP2)	Total-supply output voltage	(V _{CC2} – V _{EE2})	–0.3	35	V
V _(OUTH)	Positive gate-driver output voltage	V _{EE2} – 0.3	V _{CC2} + 0.3	V	
V _(OUTL)	Negative gate-driver output voltage	V _{EE2} – 0.3	V _{CC2} + 0.3	V	
I _(OUTH)	Gate-driver high output current	Maximum pulse width = 10 μs, Maximum duty cycle = 0.2%		2.7	A
I _(OUTL)	Gate-driver low output current	Maximum pulse width = 10 μs, Maximum duty cycle = 0.2%		5.5	A
V _(LIP)	Voltage at IN+, IN–, $\overline{\text{FLT}}$, RDY, $\overline{\text{RST}}$	GND1 – 0.3	V _{CC1} + 0.3	V	
I _(LOP)	Output current of $\overline{\text{FLT}}$, RDY			10	mA
V _(DESAT)	Voltage at DESAT	GND2 – 0.3	V _{CC2} + 0.3	V	
V _(CLAMP)	Clamp voltage	V _{EE2} – 0.3	V _{CC2} + 0.3	V	
T _J	Junction temperature	–40	150	°C	
T _{STG}	Storage temperature	–65	150	°C	

- (1) Stresses beyond those listed under *Absolute Maximum Ratings* may cause permanent damage to the device. These are stress ratings only, which do not imply functional operation of the device at these or any other conditions beyond those indicated under *Recommended Operating Conditions*. Exposure to absolute-maximum-rated conditions for extended periods may affect device reliability.

7.2 ESD Ratings

		VALUE	UNIT
V _(ESD)	Electrostatic discharge	Human-body model (HBM), per AEC Q100-002 ⁽¹⁾	±4000
		Charged-device model (CDM), per AEC Q100-011	±1500

- (1) AEC Q100-002 indicates that HBM stressing shall be in accordance with the ANSI/ESDA/JEDEC JS-001 specification.

7.3 Recommended Operating Conditions

over operating free-air temperature range (unless otherwise noted)

		MIN	NOM	MAX	UNIT
V _{CC1}	Supply-voltage input side	2.25		5.5	V
V _{CC2}	Positive supply-voltage output side (V _{CC2} – GND2)	15		30	V
V _(EE2)	Negative supply-voltage output side (V _{EE2} – GND2)	–15		0	V
V _(SUP2)	Total supply-voltage output side (V _{CC2} – V _{EE2})	15		30	V
V _(IH)	High-level input voltage (IN+, IN–, $\overline{\text{RST}}$)	0.7 × V _{CC1}		V _{CC1}	V
V _(IL)	Low-level input voltage (IN+, IN–, $\overline{\text{RST}}$)	0	0.3 × V _{CC1}		V
t _{UI}	Pulse width at IN+, IN– for full output (C _{LOAD} = 1 nF)	40			ns
t _{RST}	Pulse width at $\overline{\text{RST}}$ for resetting fault latch	800			ns
T _A	Ambient temperature	–40		125	°C

7.4 Thermal Information

THERMAL METRIC ⁽¹⁾		ISO5852S-Q1	
		DW (SOIC)	
		16 PINS	
			UNIT
$R_{\theta JA}$	Junction-to-ambient thermal resistance	99.6	°C/W
$R_{\theta JC(top)}$	Junction-to-case (top) thermal resistance	48.5	°C/W
$R_{\theta JB}$	Junction-to-board thermal resistance	56.5	°C/W
Ψ_{JT}	Junction-to-top characterization parameter	29.2	°C/W
Ψ_{JB}	Junction-to-board characterization parameter	56.5	°C/W

(1) For more information about traditional and new thermal metrics, see the [Semiconductor and IC Package Thermal Metrics](#) application report.

7.5 Power Ratings

Full-chip power dissipation is derated 10.04 mW/°C beyond 25°C ambient temperature. At 125°C ambient temperature, a maximum of 251 mW total power dissipation is allowed. Power dissipation can be optimized depending on ambient temperature and board design, while ensuring that the junction temperature does not exceed 150°C.

PARAMETER		TEST CONDITIONS	MIN	TYP	MAX	UNIT
P_D	Maximum power dissipation (both sides)	$V_{CC1} = 5.5\text{-V}$, $V_{CC2} = 30\text{-V}$, $T_A = 25^\circ\text{C}$			1255	mW
P_{ID}	Maximum input power dissipation	$V_{CC1} = 5.5\text{-V}$, $V_{CC2} = 30\text{-V}$, $T_A = 25^\circ\text{C}$			175	mW
P_{OD}	Maximum output power dissipation	$V_{CC1} = 5.5\text{-V}$, $V_{CC2} = 30\text{-V}$, $T_A = 25^\circ\text{C}$			1080	mW

7.6 Insulation Specifications

PARAMETER		TEST CONDITIONS	VALUE	UNIT
GENERAL				
CLR	External clearance ⁽¹⁾	Shortest terminal-to-terminal distance through air	8	mm
CPG	External creepage ⁽¹⁾	Shortest terminal-to-terminal distance across the package surface	8	mm
DTI	Distance through the insulation	Minimum internal gap (internal clearance)	21	μm
CTI	Comparative tracking index	DIN EN 60112 (VDE 0303-11); IEC 60112; Material Group I according to IEC 60664-1; UL 746A	>600	V
	Material group		I	
	Overvoltage Category	Rated mains voltage ≤ 600 V _{RMS}	I-IV	
		Rated mains voltage ≤ 1000 V _{RMS}	I-III	
DIN V VDE V 0884-10 (VDE V 0884-10):2006-12⁽²⁾				
V _{IORM}	Maximum repetitive peak isolation voltage	AC voltage (bipolar)	2121	V _{PK}
V _{IOWM}	Maximum isolation working voltage	AC voltage (sine wave) Time dependent dielectric breakdown (TDDB) test, see Figure 1	1500	V _{RMS}
		DC voltage	2121	V _{DC}
V _{IOTM}	Maximum transient isolation voltage	V _{TEST} = V _{IOTM} ; t = 60 s (qualification); t = 1 s (100% production)	8000	V _{PK}
V _{IOSM}	Maximum surge isolation voltage ⁽³⁾	Test method per IEC 60065, 1.2/50 μs waveform, V _{TEST} = 1.6 × V _{IOSM} = 12800 V _{PK} (qualification)	8000	
q _{pd}	Apparent charge ⁽⁴⁾	Method a: After I/O safety test subgroup 2/3, V _{ini} = V _{IOTM} , t _{ini} = 60 s; V _{pd(m)} = 1.2 × V _{IORM} = 2545 V _{PK} , t _m = 10 s	≤5	pC
		Method a: After environmental tests subgroup 1, V _{ini} = V _{IOTM} , t _{ini} = 60 s; V _{pd(m)} = 1.6 × V _{IORM} = 3394 V _{PK} , t _m = 10 s	≤5	
		Method b1: At routine test (100% production) and preconditioning (type test) V _{ini} = V _{IOTM} , t _{ini} = 60 s; V _{pd(m)} = 1.875 × V _{IORM} = 3977 V _{PK} , t _m = 10 s	≤5	
C _{IO}	Barrier capacitance, input to output ⁽⁵⁾	V _{IO} = 0.4 sin (2πft), f = 1 MHz	1	pF
R _{IO}	Isolation resistance, input to output ⁽⁵⁾	V _{IO} = 500 V, T _A = 25°C	> 10 ¹²	Ω
		V _{IO} = 500 V, 100°C ≤ T _A ≤ 125°C	> 10 ¹¹	
		V _{IO} = 500 V at T _S = 150°C	> 10 ⁹	
	Pollution degree		2	
	Climatic category			
UL 1577				
V _{ISO}	Withstand isolation voltage	V _{TEST} = V _{ISO} = 5700 V _{RMS} , t = 60 s (qualification); V _{TEST} = 1.2 × V _{ISO} = 6840 V _{RMS} , t = 1 s (100% production)	5700	V _{RMS}

- (1) Creepage and clearance requirements should be applied according to the specific equipment isolation standards of an application. Care should be taken to maintain the creepage and clearance distance of a board design to ensure that the mounting pads of the isolator on the printed-circuit board do not reduce this distance. Creepage and clearance on a printed-circuit board become equal in certain cases. Techniques such as inserting grooves and/or ribs on a printed circuit board are used to help increase these specifications.
- (2) This coupler is suitable for *safe electrical insulation* only within the maximum operating ratings. Compliance with the safety ratings shall be ensured by means of suitable protective circuits.
- (3) Testing is carried out in air or oil to determine the intrinsic surge immunity of the isolation barrier.
- (4) Apparent charge is electrical discharge caused by a partial discharge (pd).
- (5) All pins on each side of the barrier tied together creating a two-terminal device

7.7 Safety Limiting Values

Safety limiting intends to minimize potential damage to the isolation barrier upon failure of input or output circuitry. A failure of the I/O can allow low resistance to ground or the supply and, without current limiting, dissipate sufficient power to overheat the die and damage the isolation barrier, potentially leading to secondary system failures.

PARAMETER	TEST CONDITIONS	MIN	TYP	MAX	UNIT
I _S	R _{θJA} = 99.6°C/W, V _I = 2.75 V, T _J = 150°C, T _A = 25°C, see Figure 2			456	mA
	R _{θJA} = 99.6°C/W, V _I = 3.6 V, T _J = 150°C, T _A = 25°C, see Figure 2			346	
	R _{θJA} = 99.6°C/W, V _I = 5.5 V, T _J = 150°C, T _A = 25°C, see Figure 2			228	
	R _{θJA} = 99.6°C/W, V _I = 15 V, T _J = 150°C, T _A = 25°C, see Figure 2			84	
	R _{θJA} = 99.6°C/W, V _I = 30 V, T _J = 150°C, T _A = 25°C, see Figure 2			42	
P _S	Safety input, output, or total power			255 ⁽¹⁾	mW
T _S	Maximum ambient safety temperature			150	°C

(1) Input, output, or the sum of input and output power should not exceed this value

The safety-limiting constraint is the maximum junction temperature specified in the data sheet. The power dissipation and junction-to-air thermal impedance of the device installed in the application hardware determines the junction temperature. The assumed junction-to-air thermal resistance in the [Thermal Information](#) table is that of a device installed on a high-K test board for leaded surface-mount packages. The power is the recommended maximum input voltage times the current. The junction temperature is then the ambient temperature plus the power times the junction-to-air thermal resistance.

7.8 Safety-Related Certifications

VDE	CSA	UL	CQC	TUV
Certified according to DIN V VDE V 0884-10 (VDE V 0884-10):2006-12 and DIN EN 61010-1 (VDE 0411-1):2011-07	Plan to certify under CSA Component Acceptance Notice 5A, IEC 60950-1, and IEC 60601-1	Recognized under UL 1577 Component Recognition Program	Certified according to GB4943.1-2011	Certified according to EN 61010-1:2010 (3rd Ed) and EN 60950-1:2006/A11:2009/A1:2010/A12:2011/A2:2013
Reinforced Insulation Maximum Transient isolation voltage, 8000 V _{PK} ; Maximum surge isolation voltage, 8000 V _{PK} ; Maximum repetitive peak isolation voltage, 2121 V _{PK}	Isolation Rating of 5700 V _{RMS} ; Reinforced insulation per CSA 60950-1-07+A1+A2 and IEC 60950-1 (2nd Ed.), 800 V _{RMS} max working voltage (pollution degree 2, material group I) ; 2 MOPP (Means of Patient Protection) per CSA 60601-1:14 and IEC 60601-1 Ed. 3.1, 250 V _{RMS} (354 V _{PK}) max working voltage	Single Protection, 5700 V _{RMS} ⁽¹⁾	Reinforced Insulation, Altitude ≤ 5000m, Tropical climate, 400 V _{RMS} maximum working voltage	5700 V _{RMS} Reinforced insulation per EN 61010-1:2010 (3rd Ed) up to working voltage of 600 V _{RMS} 5700 V _{RMS} Reinforced insulation per EN 60950-1:2006/A11:2009/A1:2010/A12:2011/A2:2013 up to working voltage of 800 V _{RMS}
Certification completed Certificate number: 40040142	Certificate planned	Certification completed File number: E181974	Certification completed Certificate number: CQC16001141761	Certification completed Client ID number: 77311

(1) Production tested ≥ 6840 VRMS for 1 second in accordance with UL 1577.

7.9 Electrical Characteristics

Over recommended operating conditions unless otherwise noted. All typical values are at $T_A = 25^\circ\text{C}$, $V_{CC1} = 5\text{ V}$, $V_{CC2} - \text{GND2} = 15\text{ V}$, $\text{GND2} - V_{EE2} = 8\text{ V}$

PARAMETER		TEST CONDITIONS	MIN	TYP	MAX	UNIT
VOLTAGE SUPPLY						
$V_{IT+}(\text{UVLO1})$	Positive-going UVLO1 threshold-voltage input side ($V_{CC1} - \text{GND1}$)				2.25	V
$V_{IT-}(\text{UVLO1})$	Negative-going UVLO1 threshold-voltage input side ($V_{CC1} - \text{GND1}$)		1.7			V
$V_{HYS}(\text{UVLO1})$	UVLO1 Hysteresis voltage ($V_{IT+} - V_{IT-}$) input side			0.2		V
$V_{IT+}(\text{UVLO2})$	Positive-going UVLO2 threshold-voltage output side ($V_{CC2} - \text{GND2}$)			12	13	V
$V_{IT-}(\text{UVLO2})$	Negative-going UVLO2 threshold-voltage output side ($V_{CC2} - \text{GND2}$)		9.5	11		V
$V_{HYS}(\text{UVLO2})$	UVLO2 hysteresis voltage ($V_{IT+} - V_{IT-}$) output side			1		V
I_{Q1}	Input-supply quiescent current			2.8	4.5	mA
I_{Q2}	Output-supply quiescent current			3.6	6	mA
LOGIC I/O						
$V_{IT+}(\text{IN,RST})$	Positive-going input-threshold voltage (IN+, IN-, RST)				$0.7 \times V_{CC1}$	V
$V_{IT-}(\text{IN,RST})$	Negative-going input-threshold voltage (IN+, IN-, RST)		$0.3 \times V_{CC1}$			V
$V_{HYS}(\text{IN,RST})$	Input hysteresis voltage (IN+, IN-, RST)			$0.15 \times V_{CC1}$		V
I_{IH}	High-level input leakage at (IN+) ⁽¹⁾	$\text{IN+} = V_{CC1}$		100		μA
I_{IL}	Low-level input leakage at (IN-, RST) ⁽²⁾	$\text{IN-} = \text{GND1}$, $\text{RST} = \text{GND1}$		-100		μA
I_{PU}	Pullup current of FLT, RDY	$V_{(\text{RDY})} = \text{GND1}$, $V_{(\text{FLT})} = \text{GND1}$		100		μA
$V_{(\text{OL})}$	Low-level output voltage at FLT, RDY	$I_{(\text{FLT})} = 5\text{ mA}$			0.2	V
GATE DRIVER STAGE						
$V_{(\text{OUTPD})}$	Active output pulldown voltage	$I_{(\text{OUTH/L})} = 200\text{ mA}$, $V_{CC2} = \text{open}$			2	V
$V_{(\text{OUTH})}$	High-level output voltage	$I_{(\text{OUTH})} = -20\text{ mA}$	$V_{CC2} - 0.5$	$V_{CC2} - 0.24$		V
$V_{(\text{OUTL})}$	Low-level output voltage	$I_{(\text{OUTL})} = 20\text{ mA}$		$V_{EE2} + 13$	$V_{EE2} + 50$	mV
$I_{(\text{OUTH})}$	High-level output peak current	$\text{IN+} = \text{high}$, $\text{IN-} = \text{low}$, $V_{(\text{OUTH})} = V_{CC2} - 15\text{ V}$	1.5	2.5		A
$I_{(\text{OUTL})}$	Low-level output peak current	$\text{IN+} = \text{low}$, $\text{IN-} = \text{high}$, $V_{(\text{OUTL})} = V_{EE2} + 15\text{ V}$	3.4	5		A
$I_{(\text{OLF})}$	Low-level output current during fault condition			130		mA
ACTIVE MILLER CLAMP						
$V_{(\text{CLP})}$	Low-level clamp voltage	$I_{(\text{CLP})} = 20\text{ mA}$		$V_{EE2} + 0.015$	$V_{EE2} + 0.08$	V
$I_{(\text{CLP})}$	Low-level clamp current	$V_{(\text{CLAMP})} = V_{EE2} + 2.5\text{ V}$	1.6	2.5	3.3	A
$V_{(\text{CLTH})}$	Clamp threshold voltage		1.6	2.1	2.5	V
SHORT CIRCUIT CLAMPING						
$V_{(\text{CLP-OUTH})}$	Clamping voltage ($V_{(\text{OUTH})} - V_{CC2}$)	$\text{IN+} = \text{high}$, $\text{IN-} = \text{low}$, $t_{\text{CLP}} = 10\ \mu\text{s}$, $I_{(\text{OUTH})} = 500\text{ mA}$		1.1	1.3	V
$V_{(\text{CLP-OUTL})}$	Clamping voltage ($V_{(\text{OUTL})} - V_{CC2}$)	$\text{IN+} = \text{high}$, $\text{IN-} = \text{low}$, $t_{\text{CLP}} = 10\ \mu\text{s}$, $I_{(\text{OUTL})} = 500\text{ mA}$		1.3	1.5	V
$V_{(\text{CLP-CLP})}$	Clamping voltage ($V_{(\text{CLP})} - V_{CC2}$)	$\text{IN+} = \text{high}$, $\text{IN-} = \text{low}$, $t_{\text{CLP}} = 10\ \mu\text{s}$, $I_{(\text{CLP})} = 500\text{ mA}$		1.3		V
$V_{(\text{CLP-CLAMP})}$	Clamping voltage at CLAMP	$\text{IN+} = \text{High}$, $\text{IN-} = \text{Low}$, $I_{(\text{CLP})} = 20\text{ mA}$		0.7	1.1	V
$V_{(\text{CLP-OUTL})}$	Clamping voltage at OUTL ($V_{(\text{CLP})} - V_{CC2}$)	$\text{IN+} = \text{High}$, $\text{IN-} = \text{Low}$, $I_{(\text{OUTL})} = 20\text{ mA}$		0.7	1.1	V
DESAT PROTECTION						
$I_{(\text{CHG})}$	Blanking-capacitor charge current	$V_{(\text{DESAT})} - \text{GND2} = 2\text{ V}$	0.42	0.5	0.58	mA
$I_{(\text{DCHG})}$	Blanking-capacitor discharge current	$V_{(\text{DESAT})} - \text{GND2} = 6\text{ V}$	9	14		mA

(1) I_{IH} for IN-, RST pin is zero as they are pulled high internally

(2) I_{IL} for IN+ is zero, as it is pulled low internally

Electrical Characteristics (continued)

Over recommended operating conditions unless otherwise noted. All typical values are at $T_A = 25^\circ\text{C}$, $V_{CC1} = 5\text{ V}$, $V_{CC2} - \text{GND2} = 15\text{ V}$, $\text{GND2} - V_{EE2} = 8\text{ V}$

PARAMETER	TEST CONDITIONS	MIN	TYP	MAX	UNIT
$V_{(\text{DSTH})}$	DESAT threshold voltage with respect to GND2	8.3	9	9.5	V
$V_{(\text{DSL})}$	DESAT voltage with respect to GND2, when OUTH or OUTL is driven low	0.4		1	V

7.10 Switching Characteristics

Over recommended operating conditions unless otherwise noted. All typical values are at $T_A = 25^\circ\text{C}$, $V_{CC1} = 5\text{ V}$, $V_{CC2} - \text{GND2} = 15\text{ V}$, $\text{GND2} - V_{EE2} = 8\text{ V}$

PARAMETER	TEST CONDITIONS	MIN	TYP	MAX	UNIT
t_r	Output-signal rise time at OUTH $C_{\text{LOAD}} = 1\text{ nF}$	12	18	35	ns
t_f	Output-signal fall time at OUTL $C_{\text{LOAD}} = 1\text{ nF}$	12	20	37	ns
$t_{\text{PLH}}, t_{\text{PHL}}$	Propagation Delay $C_{\text{LOAD}} = 1\text{ nF}$		76	110	ns
$t_{\text{sk-p}}$	Pulse skew $ t_{\text{PHL}} - t_{\text{PLH}} $ $C_{\text{LOAD}} = 1\text{ nF}$			20	ns
$t_{\text{sk-pp}}$	Part-to-part skew $C_{\text{LOAD}} = 1\text{ nF}$			30 ⁽¹⁾	ns
$t_{\text{GF}} (\text{IN}/\text{RST})$	Glitch filter on IN+, IN-, $\overline{\text{RST}}$ $C_{\text{LOAD}} = 1\text{ nF}$	20	30	40	ns
$t_{\text{DS}} (90\%)$	DESAT sense to 90% $V_{\text{OUTH/L}}$ delay $C_{\text{LOAD}} = 10\text{ nF}$		553	760	ns
$t_{\text{DS}} (10\%)$	DESAT sense to 10% $V_{\text{OUTH/L}}$ delay $C_{\text{LOAD}} = 10\text{ nF}$		2	3.5	μs
$t_{\text{DS}} (\text{GF})$	DESAT-glitch filter delay $C_{\text{LOAD}} = 1\text{ nF}$		330		ns
$t_{\text{DS}} (\overline{\text{FLT}})$	DESAT sense to $\overline{\text{FLT}}$ -low delay See Figure 46			1.4	μs
t_{LEB}	Leading-edge blanking time See Figure 44 and Figure 45	310	400	480	ns
$t_{\text{GF}}(\text{RSTFLT})$	Glitch filter on $\overline{\text{RST}}$ for resetting $\overline{\text{FLT}}$	300		800	ns
C_1	Input capacitance ⁽²⁾ $V_1 = V_{CC1} / 2 + 0.4 \times \sin(2\pi ft)$, $f = 1\text{ MHz}$, $V_{CC1} = 5\text{ V}$		2		pF
CMTI	Common-mode transient immunity $V_{\text{CM}} = 1500\text{ V}$, see Figure 47	100	120		kV/ μs

- (1) Measured at same supply voltage and temperature condition
(2) Measured from input pin to ground.

7.11 Safety and Insulation Characteristics Curves

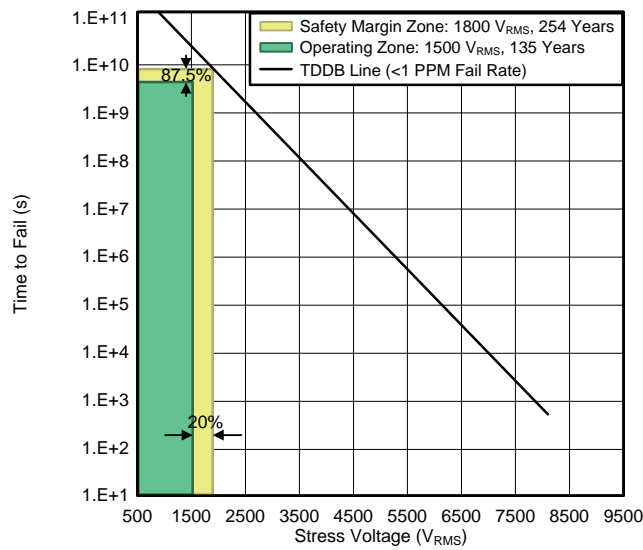

T_A upto 150°C

Stress-voltage frequency = 60 Hz

Figure 1. Reinforced High-Voltage Capacitor Lifetime Projection

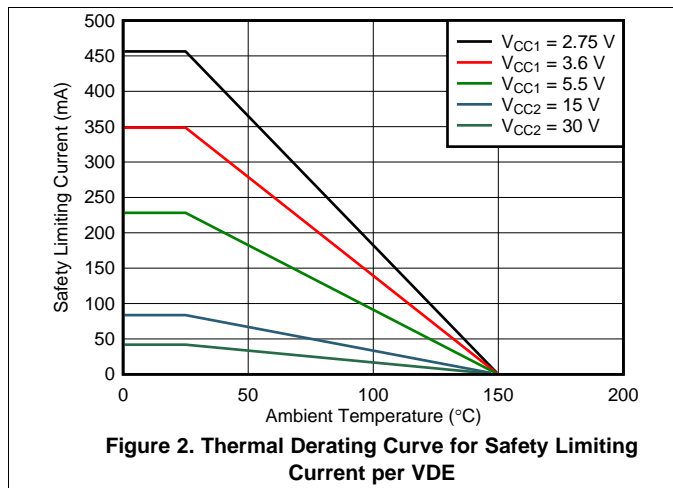

Figure 2. Thermal Derating Curve for Safety Limiting Current per VDE

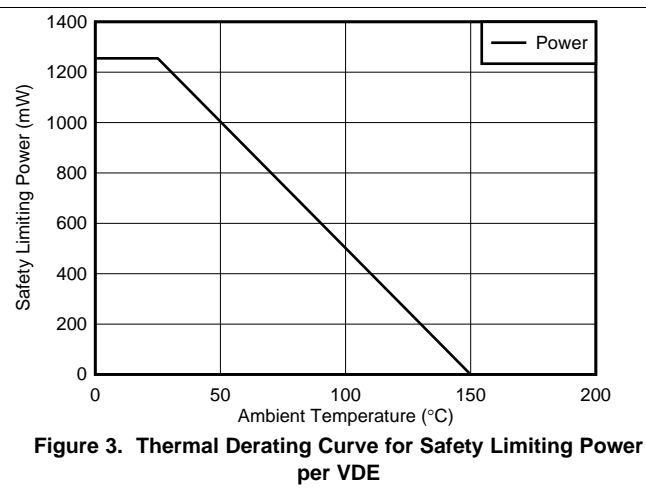

Figure 3. Thermal Derating Curve for Safety Limiting Power per VDE

7.12 Typical Characteristics

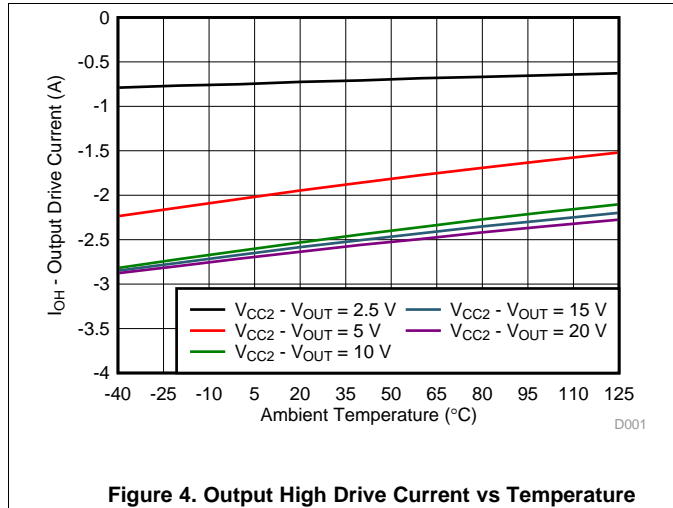

Figure 4. Output High Drive Current vs Temperature

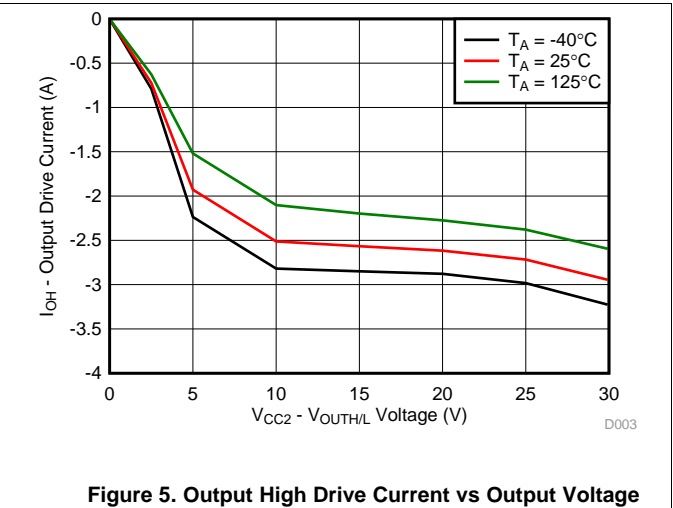

Figure 5. Output High Drive Current vs Output Voltage

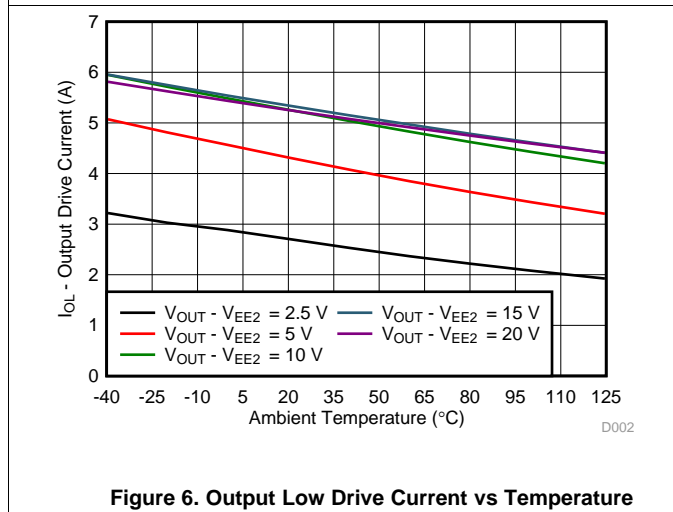

Figure 6. Output Low Drive Current vs Temperature

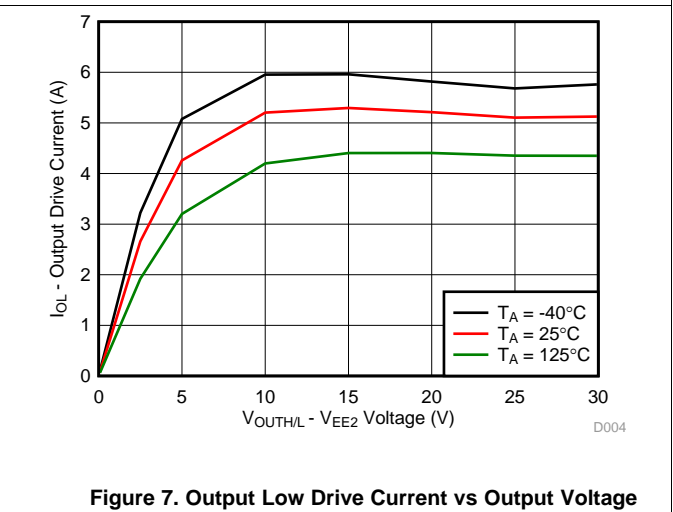

Figure 7. Output Low Drive Current vs Output Voltage

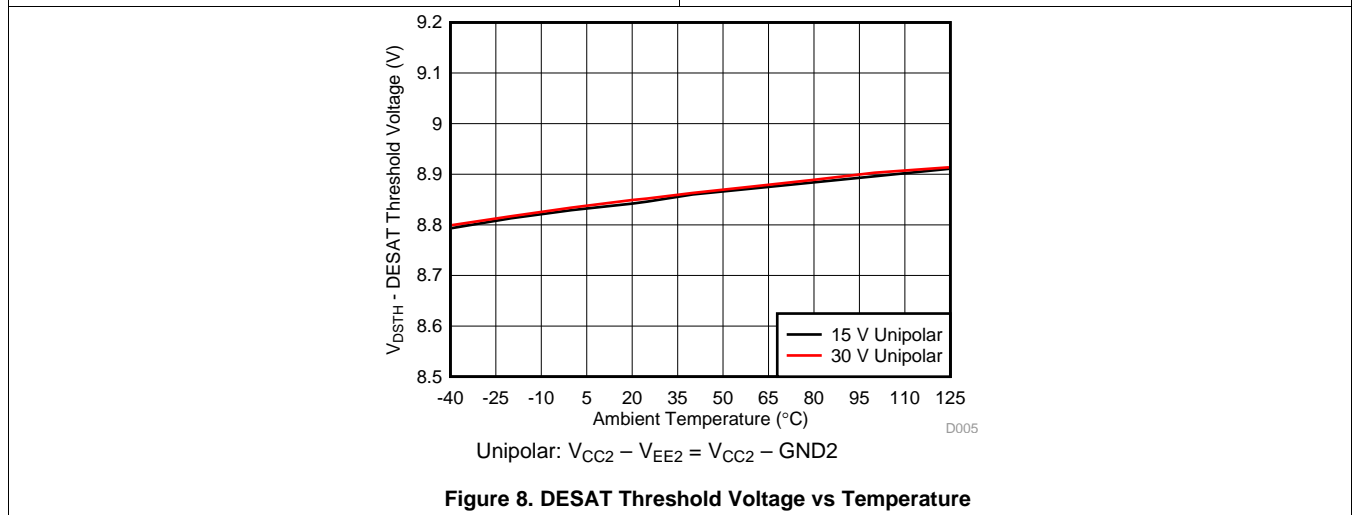
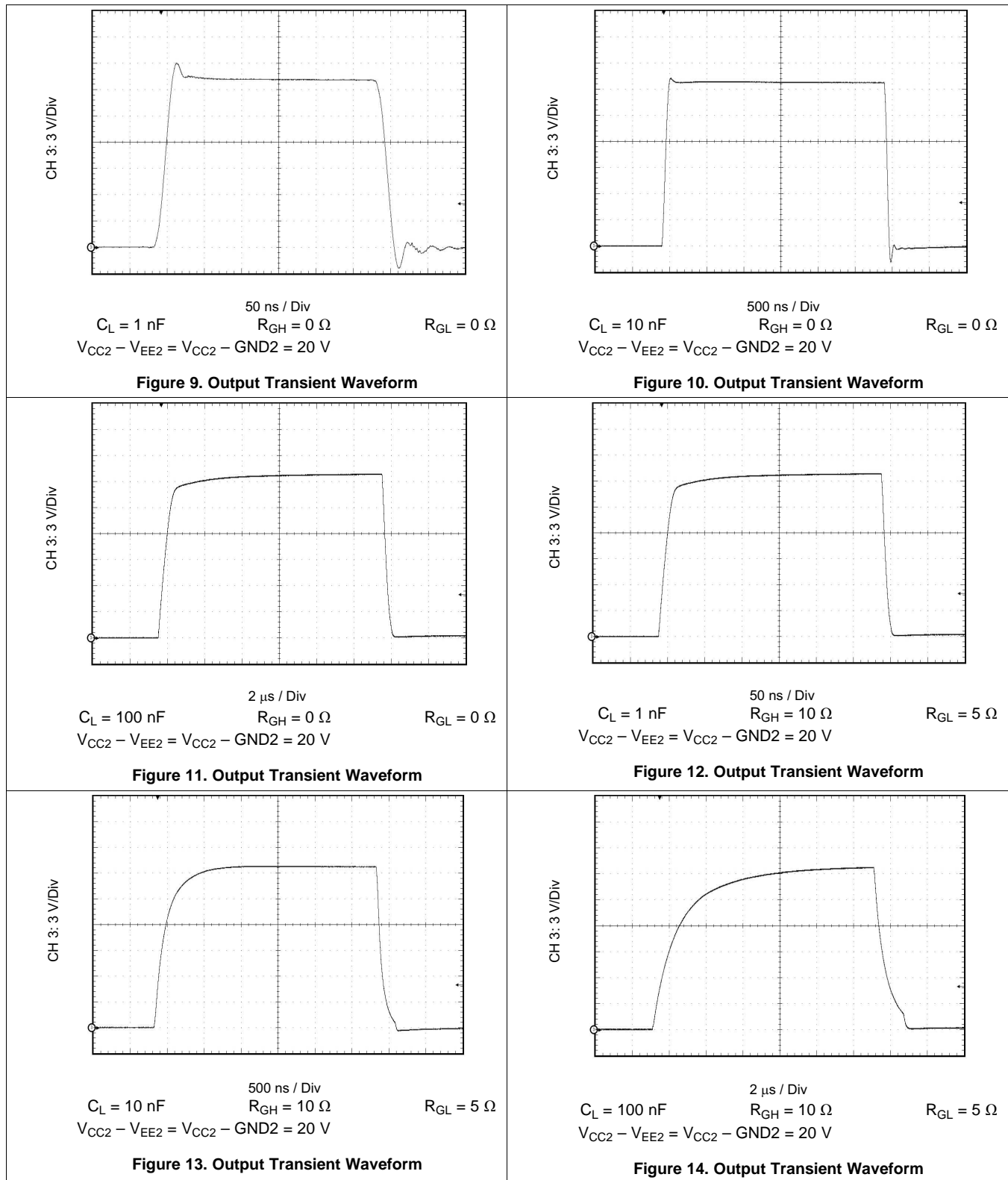
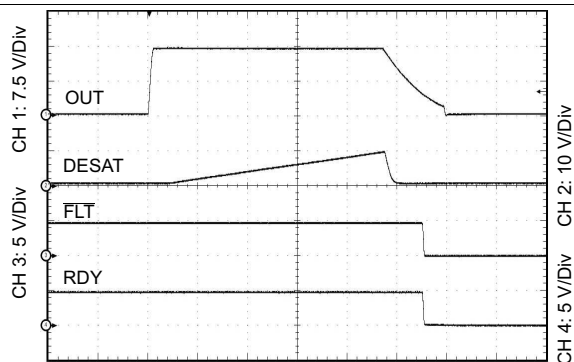

Figure 8. DESAT Threshold Voltage vs Temperature

Typical Characteristics (continued)



Typical Characteristics (continued)



1 μ s/Div
 $C_L = 10$ nF $R_{GH} = 0$ Ω $R_{GL} = 0$ Ω
 $V_{CC2} - V_{EE2} = V_{CC2} - GND2 = 15$ V DESAT = 220 pF

Figure 15. Output Transient Waveform DESAT, RDY, and FLT

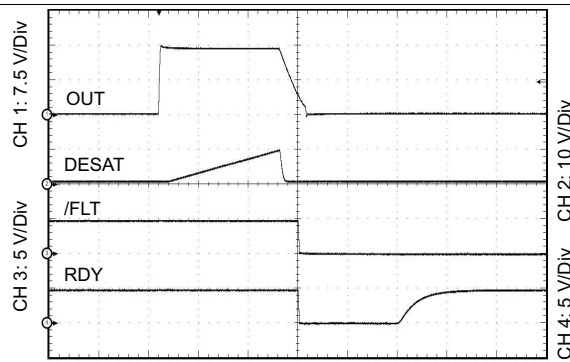

2 μ s / Div
 $C_L = 10$ nF $R_{GH} = 0$ Ω $R_{GL} = 0$ Ω
 $V_{CC2} - V_{EE2} = V_{CC2} - GND2 = 15$ V DESAT = 220 pF

Figure 16. Output Transient Waveform DESAT, RDY, and /FLT

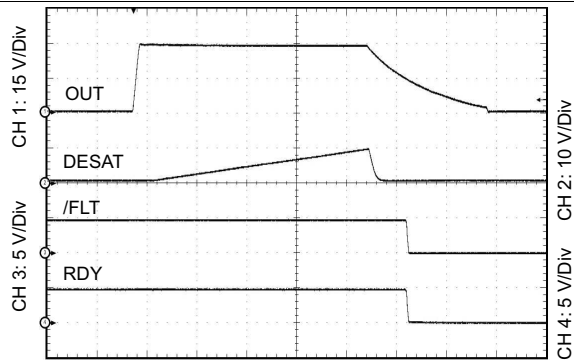

1 μ s / Div
 $C_L = 10$ nF $R_{GH} = 0$ Ω $R_{GL} = 0$ Ω
 $V_{CC2} - V_{EE2} = V_{CC2} - GND2 = 30$ V DESAT = 220 pF

Figure 17. Output Transient Waveform DESAT, RDY, and /FLT

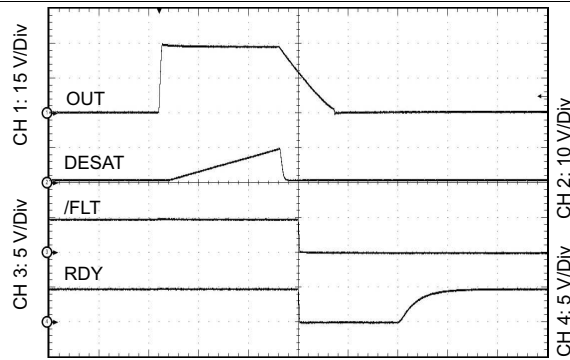

2 μ s / Div
 $C_L = 10$ nF $R_{GH} = 0$ Ω $R_{GL} = 0$ Ω
 $V_{CC2} - V_{EE2} = V_{CC2} - GND2 = 30$ V DESAT = 220 pF

Figure 18. Output Transient Waveform DESAT, RDY, and /FLT

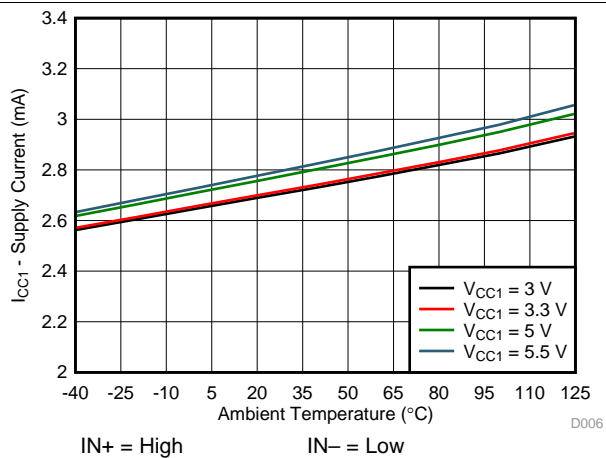

Figure 19. I_{CC1} Supply Current vs Temperature

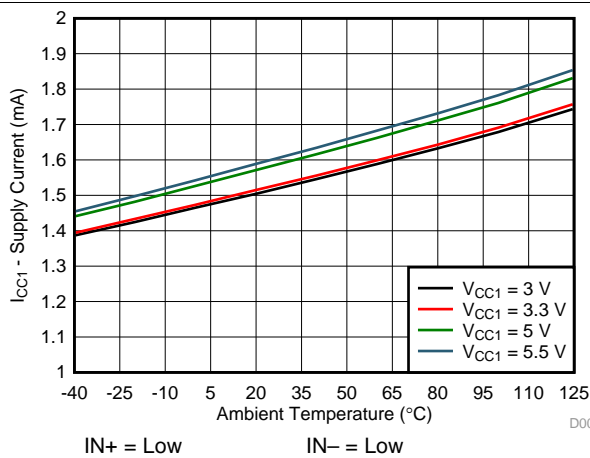

Figure 20. I_{CC1} Supply Current vs Temperature

Typical Characteristics (continued)

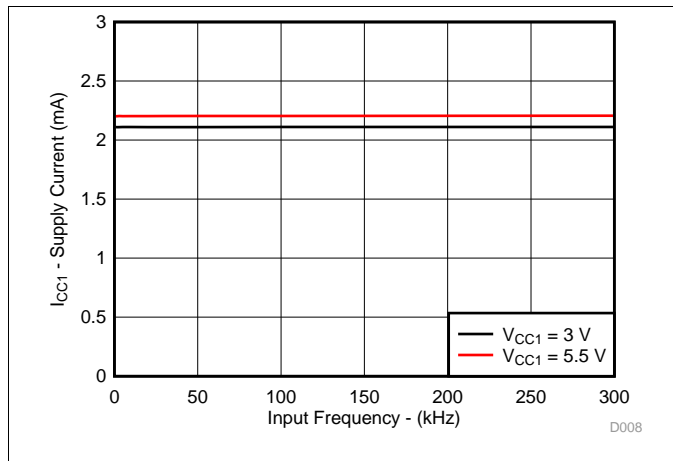
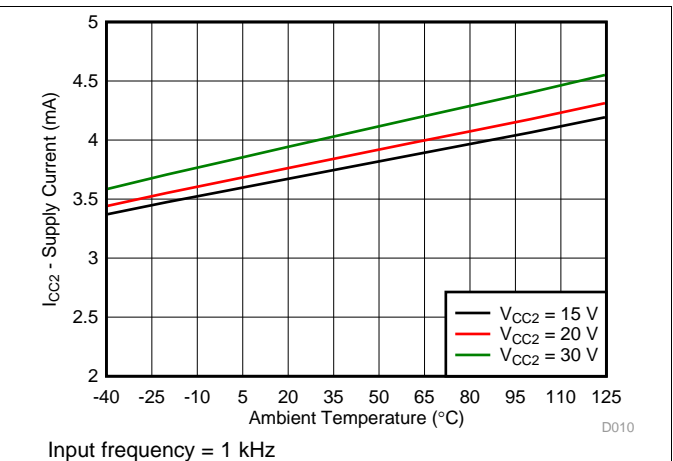

Figure 21. I_{CC1} Supply Current vs Input Frequency



Input frequency = 1 kHz

Figure 22. I_{CC2} Supply Current vs Temperature

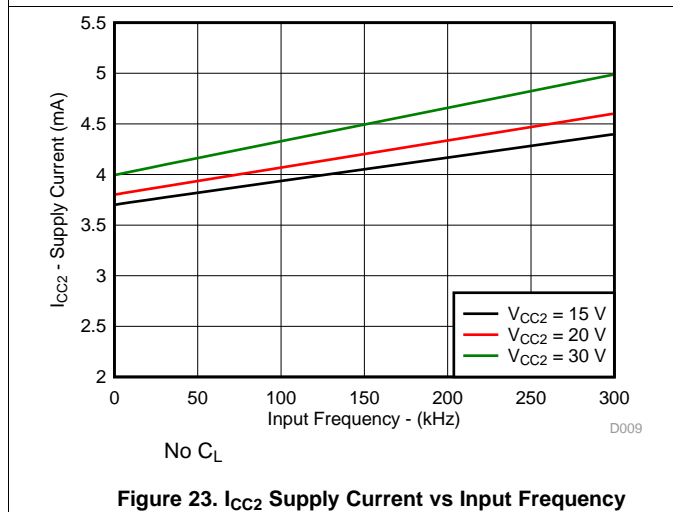
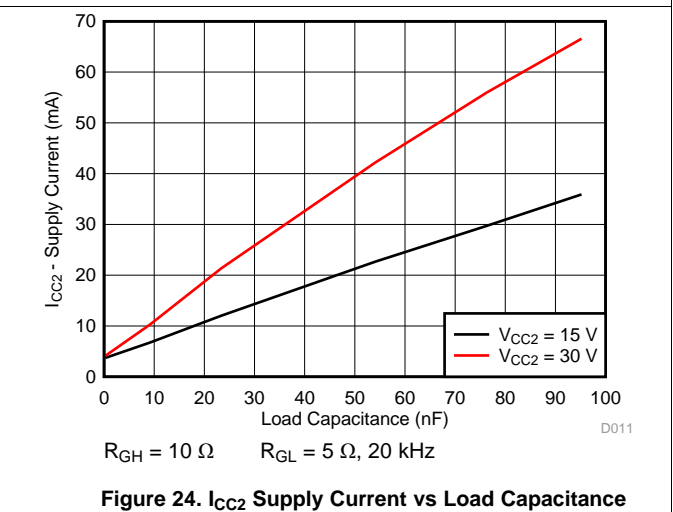
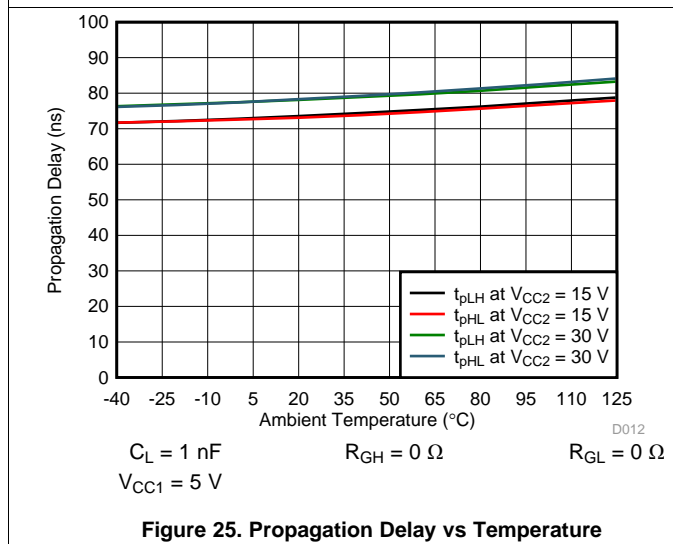

Figure 23. I_{CC2} Supply Current vs Input Frequency



$R_{GH} = 10 \Omega$ $R_{GL} = 5 \Omega, 20 \text{ kHz}$

Figure 24. I_{CC2} Supply Current vs Load Capacitance



$C_L = 1 \text{ nF}$ $R_{GH} = 0 \Omega$ $R_{GL} = 0 \Omega$
 $V_{CC1} = 5 \text{ V}$

Figure 25. Propagation Delay vs Temperature

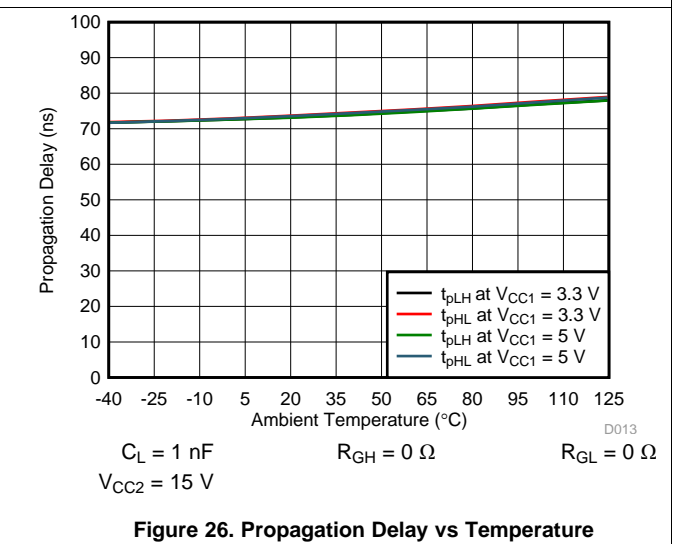

$C_L = 1 \text{ nF}$ $R_{GH} = 0 \Omega$ $R_{GL} = 0 \Omega$
 $V_{CC2} = 15 \text{ V}$

Figure 26. Propagation Delay vs Temperature

Typical Characteristics (continued)

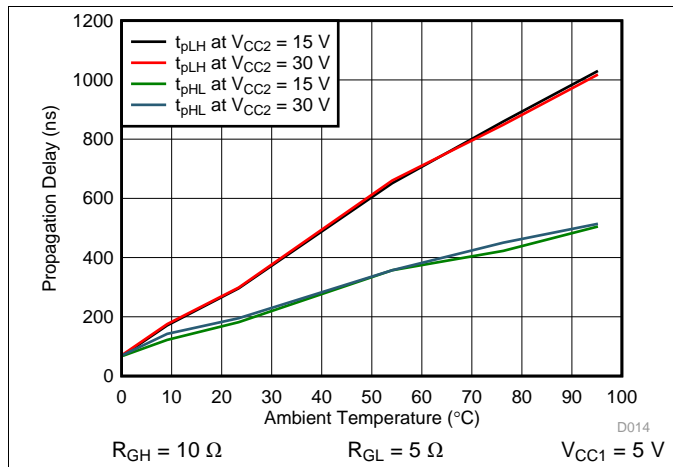

Figure 27. Propagation Delay vs Load Capacitance

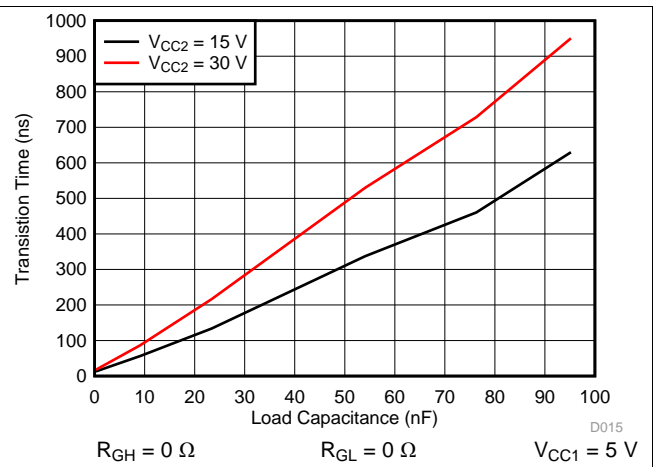

Figure 28. t_r Rise Time vs Load Capacitance

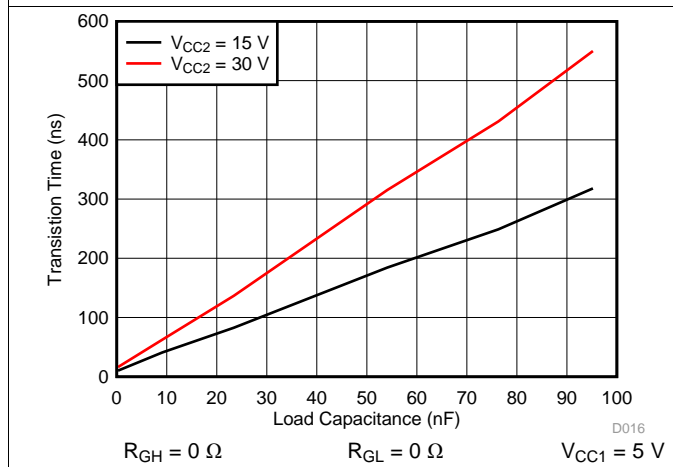

Figure 29. t_f Fall Time v. Load Capacitance

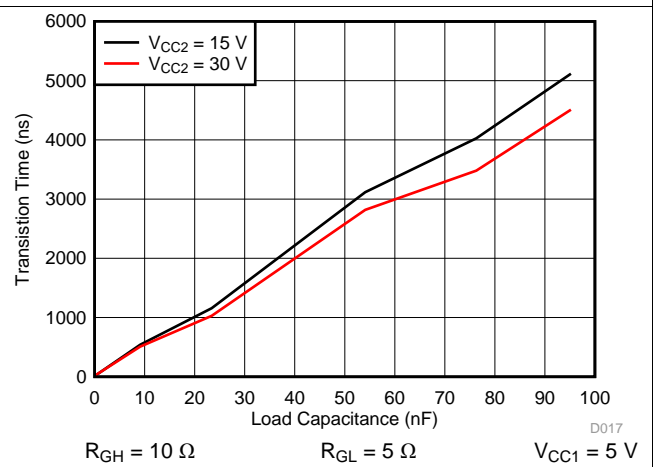

Figure 30. t_r Rise Time vs Load Capacitance

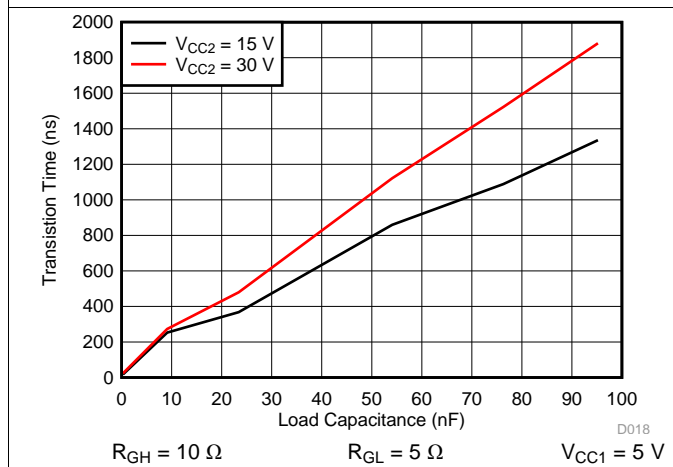

Figure 31. t_f Fall Time vs Load Capacitance

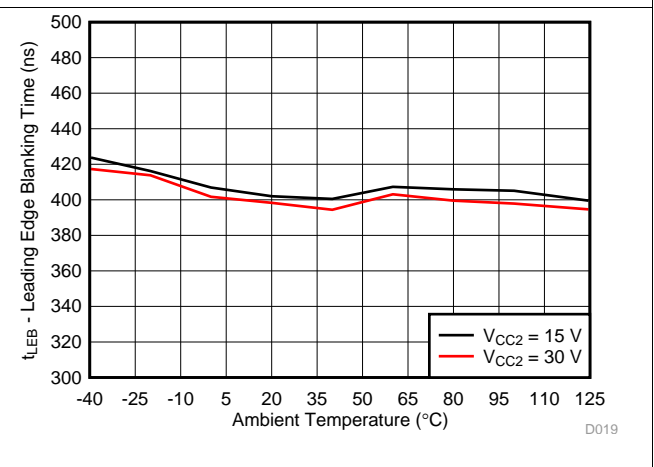

Figure 32. Leading Edge Blanking Time With Temperature

Typical Characteristics (continued)

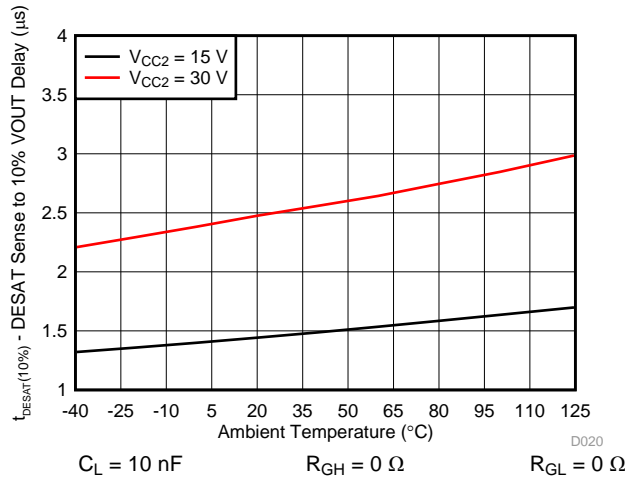

Figure 33. DESAT Sense to V_{OUT} 10% Delay vs Temperature

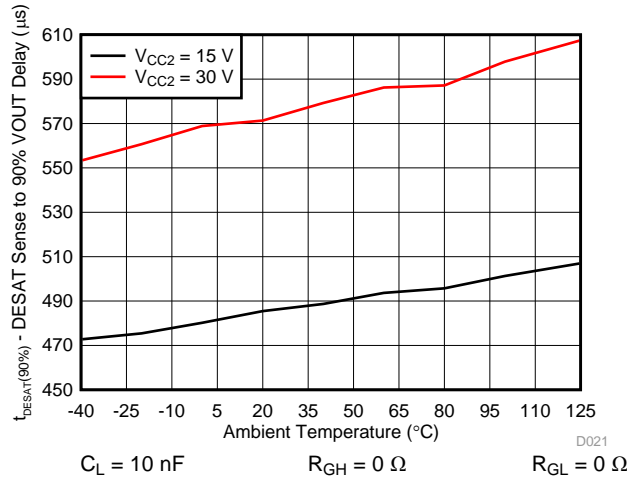

Figure 34. DESAT Sense to V_{OUT} 90% Delay vs Temperature

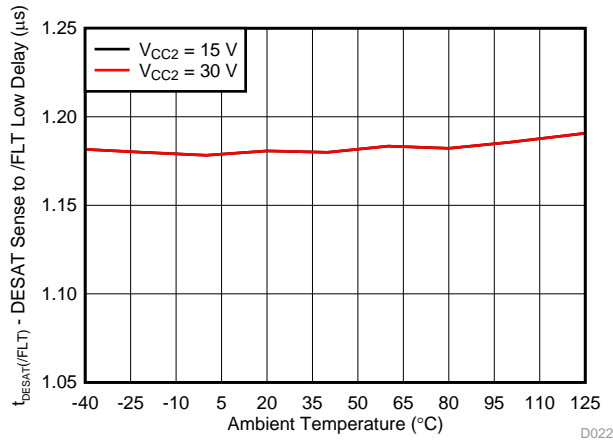

Figure 35. DESAT Sense to Fault Low Delay vs Temperature

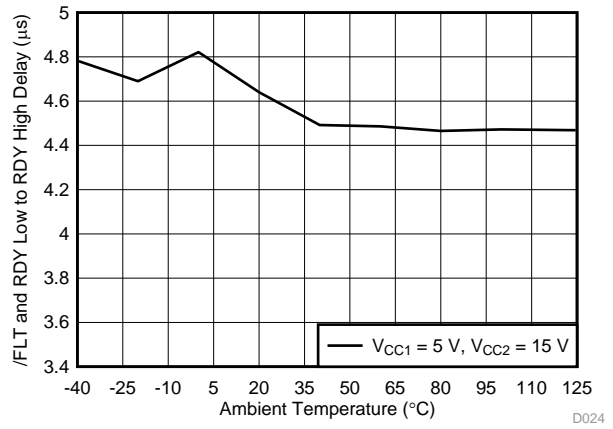

Figure 36. Fault and RDY Low to RDY High Delay vs Temperature

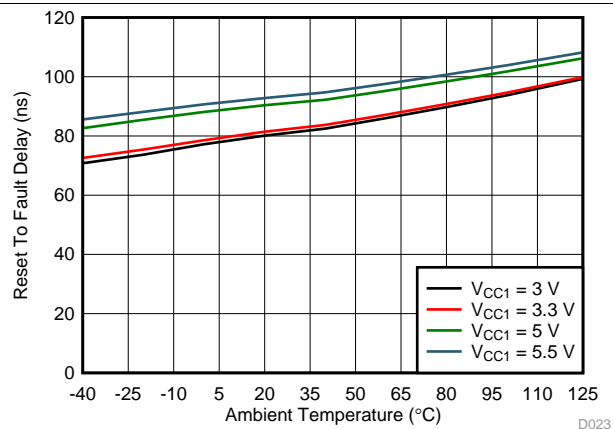

Figure 37. Reset to Fault Delay Across Temperature

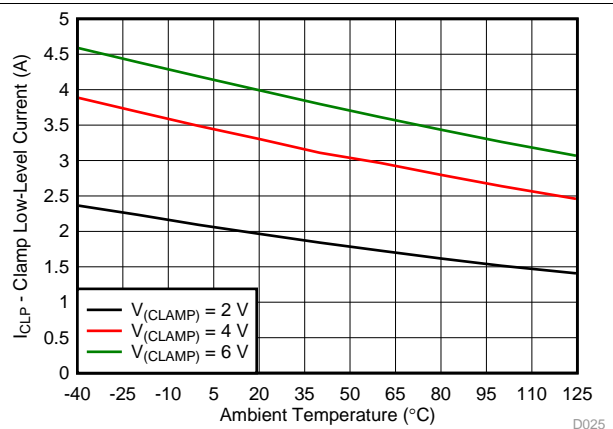
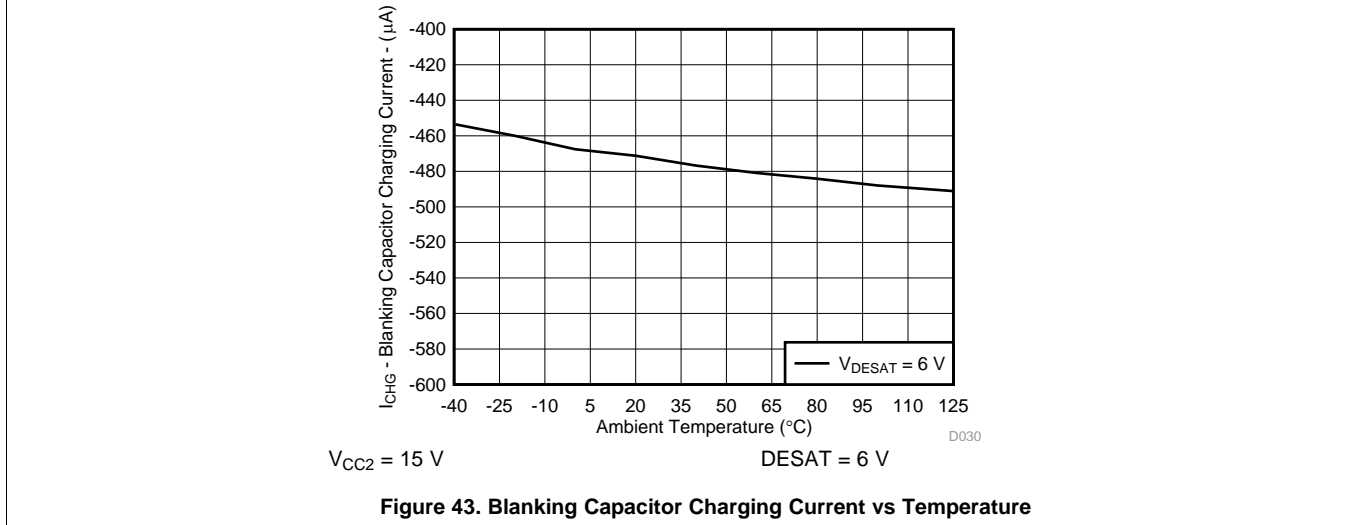
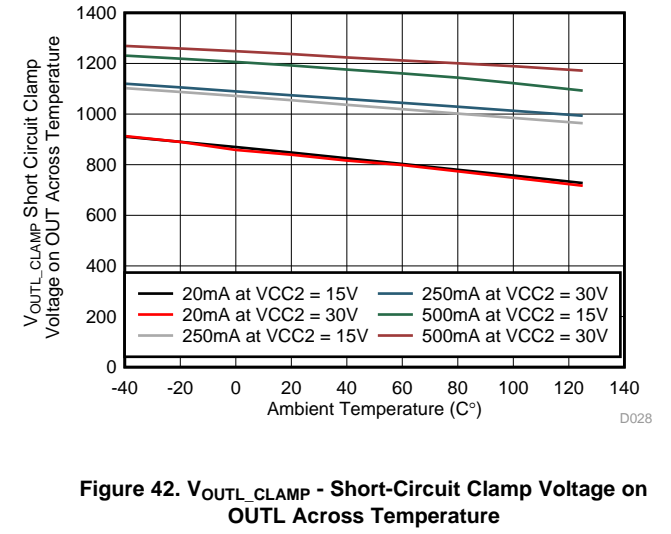
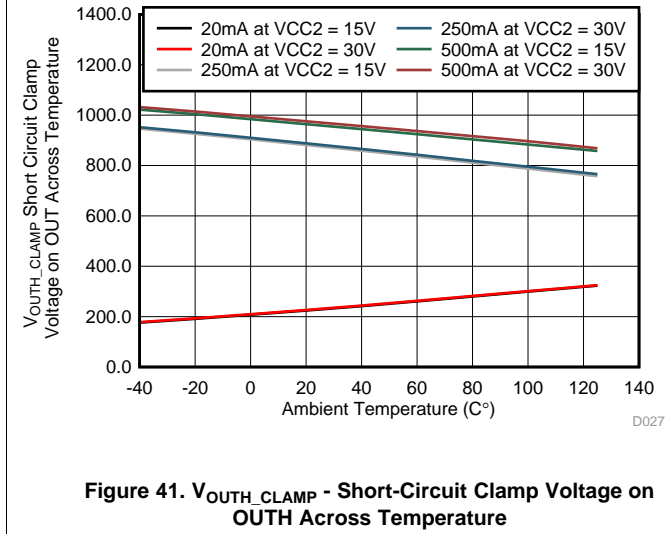
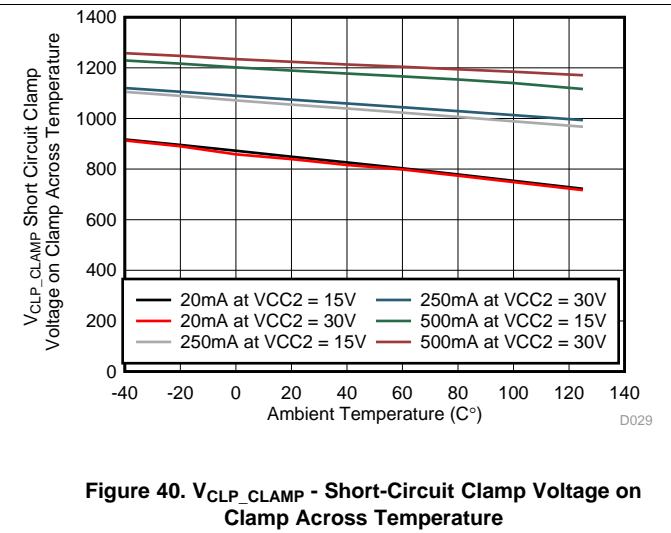
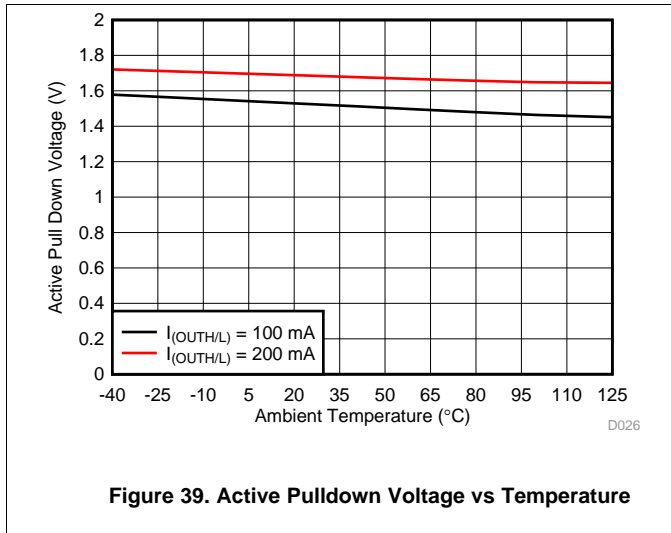

Figure 38. Miller Clamp Current vs Temperature

Typical Characteristics (continued)



8 Parameter Measurement Information

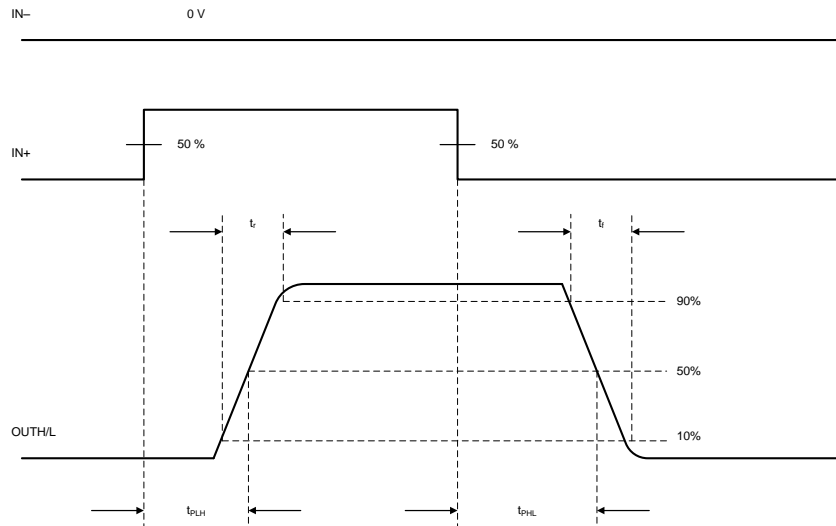

Figure 44. OUTH and OUTL Propagation Delay, Non-Inverting Configuration

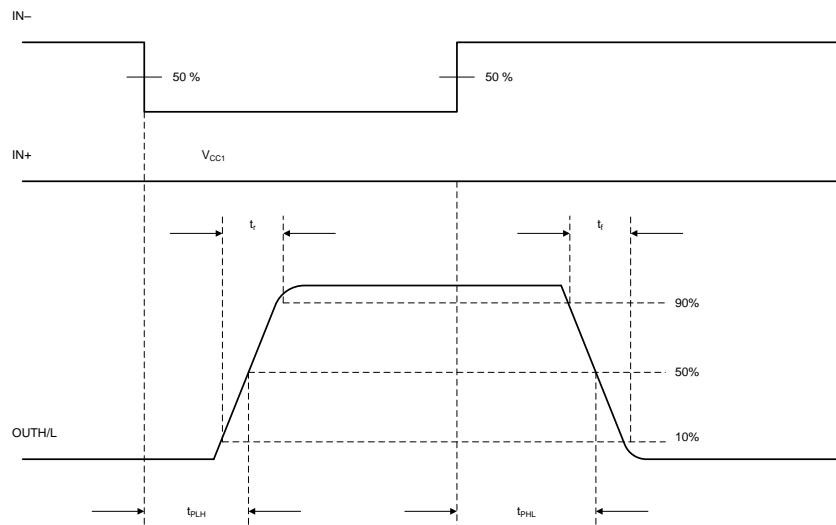

Figure 45. OUTH and OUTL Propagation Delay, Inverting Configuration

Parameter Measurement Information (continued)

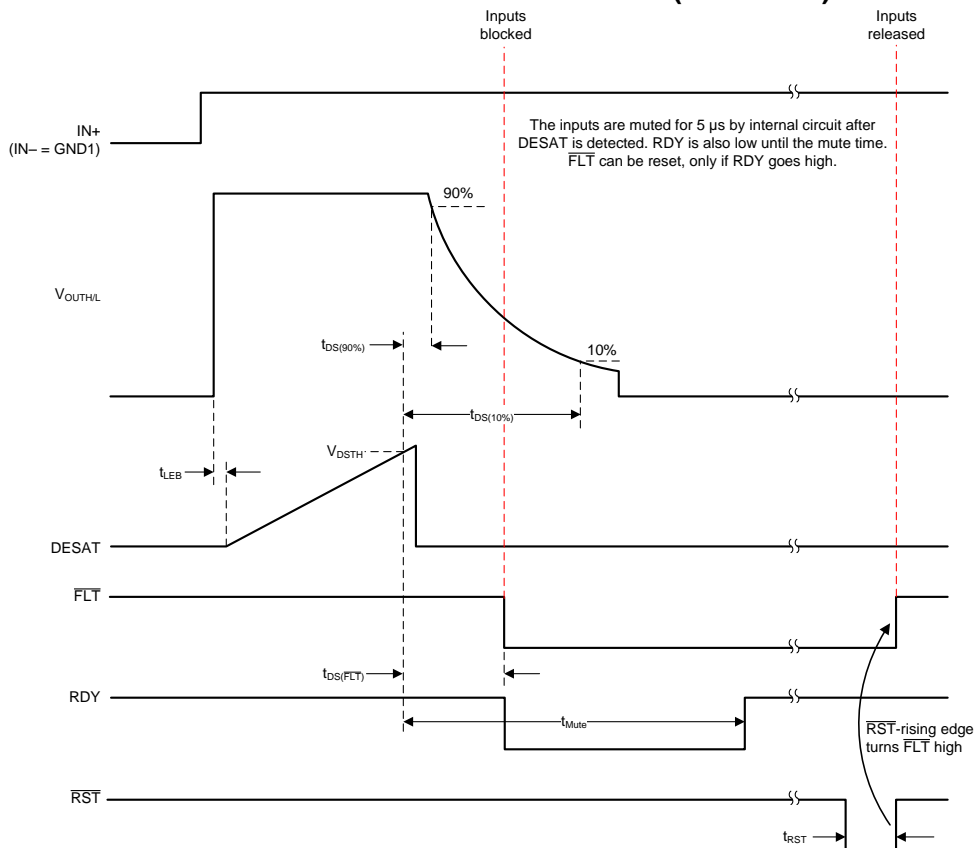

Figure 46. DESAT, OUTH/L, $\overline{\text{FLT}}$, $\overline{\text{RST}}$ Delay

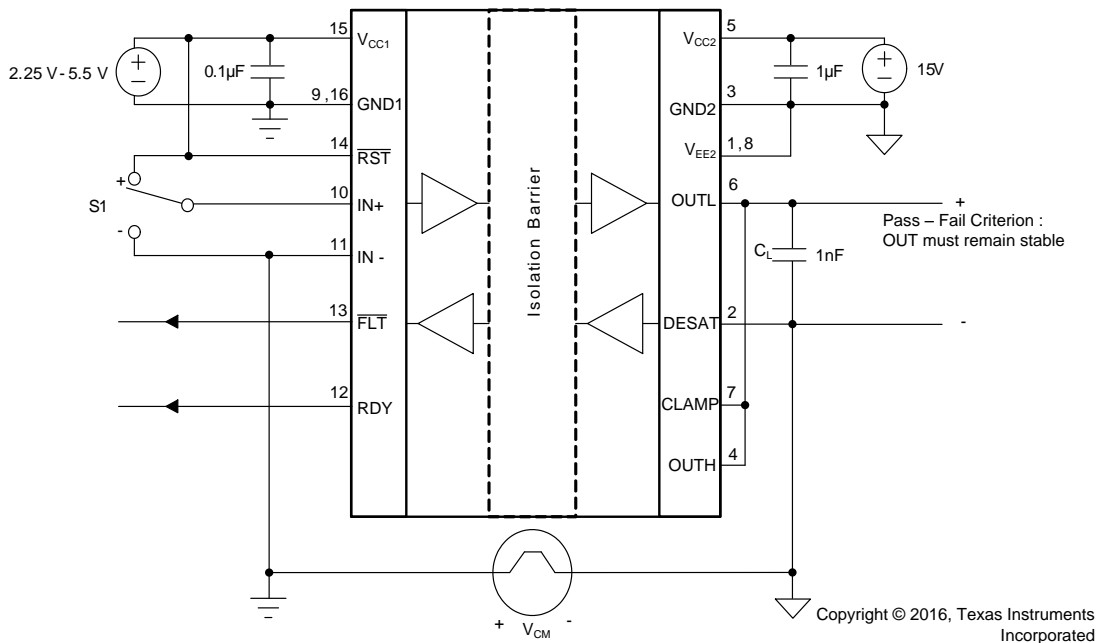

Figure 47. Common-Mode Transient Immunity Test Circuit

9 Detailed Description

9.1 Overview

The ISO5852S-Q1 is an isolated gate driver for IGBTs and MOSFETs. Input CMOS logic and output power stage are separated by a Silicon dioxide (SiO_2) capacitive isolation.

The IO circuitry on the input side interfaces with a micro controller and consists of gate drive control and RESET ($\overline{\text{RST}}$) inputs, READY (RDY) and FAULT ($\overline{\text{FLT}}$) alarm outputs. The power stage consists of power transistors to supply 2.5-A pullup and 5-A pulldown currents to drive the capacitive load of the external power transistors, as well as DESAT detection circuitry to monitor IGBT collector-emitter overvoltage under short circuit events. The capacitive isolation core consists of transmit circuitry to couple signals across the capacitive isolation barrier, and receive circuitry to convert the resulting low-swing signals into CMOS levels. The ISO5852S-Q1 also contains under voltage lockout circuitry to prevent insufficient gate drive to the external IGBT, and active output pulldown feature which ensures that the gate-driver output is held low, if the output supply voltage is absent. The ISO5852S-Q1 also has an active Miller clamp function which can be used to prevent parasitic turn-on of the external power transistor, due to Miller effect, for unipolar supply operation.

9.2 Functional Block Diagram

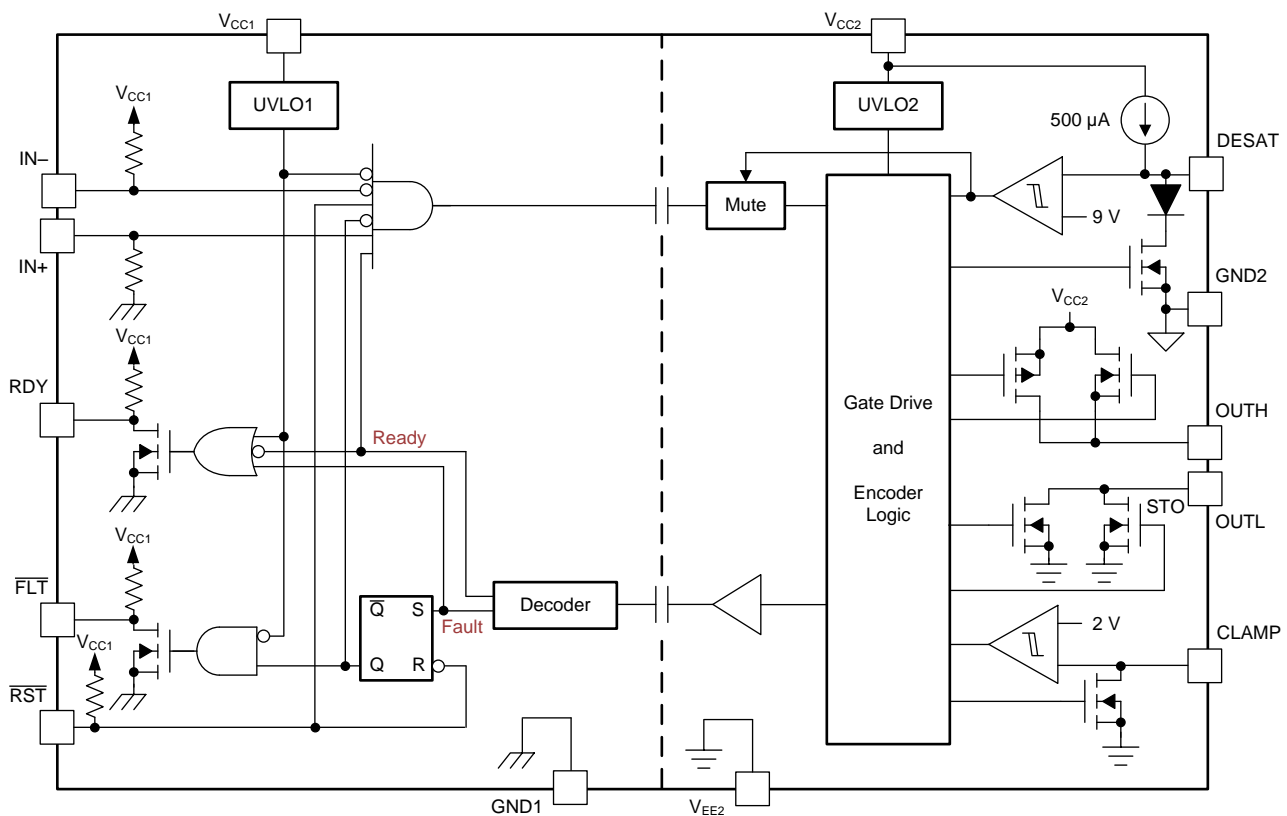

Copyright © 2016, Texas Instruments Incorporated

9.3 Feature Description

9.3.1 Supply and Active Miller clamp

The ISO5852S-Q1 supports both bipolar and unipolar power supply with active Miller clamp.

For operation with bipolar supplies, the IGBT is turned off with a negative voltage on its gate with respect to its emitter. This prevents the IGBT from unintentionally turning on because of current induced from its collector to its gate due to Miller effect. In this condition it is not necessary to connect CLAMP output of the gate driver to the IGBT gate, but connecting CLAMP output of the gate driver to the IGBT gate is also not an issue. Typical values of V_{CC2} and V_{EE2} for bipolar operation are 15-V and -8-V with respect to GND2.

For operation with unipolar supply, typically, V_{CC2} is connected to 15-V with respect to GND2, and V_{EE2} is connected to GND2. In this use case, the IGBT can turn on due to additional charge from IGBT Miller capacitance caused by a high voltage slew rate transition on the IGBT collector. To prevent IGBT to turn on, the CLAMP pin is connected to IGBT gate and Miller current is sunk through a low impedance CLAMP transistor.

Miller CLAMP is designed for Miller current up to 2-A. When the IGBT is turned-off and the gate voltage transitions below 2-V the CLAMP current output is activated.

9.3.2 Active Output Pulldown

The Active output pulldown feature ensures that the IGBT gate OUTH/L is clamped to V_{EE2} to ensure safe IGBT off-state, when the output side is not connected to the power supply.

9.3.3 Undervoltage Lockout (UVLO) With Ready (RDY) Pin Indication Output

Undervoltage Lockout (UVLO) ensures correct switching of IGBT. The IGBT is turned-off, if the supply V_{CC1} drops below $V_{IT-(UVLO1)}$, irrespective of IN+, IN– and RST input till V_{CC1} goes above $V_{IT+(UVLO1)}$.

In similar manner, the IGBT is turned-off, if the supply V_{CC2} drops below $V_{IT-(UVLO2)}$, irrespective of IN+, IN– and RST input till V_{CC2} goes above $V_{IT+(UVLO2)}$.

Ready (RDY) pin indicates status of input and output side Under Voltage Lock-Out (UVLO) internal protection feature. If either side of device have insufficient supply (V_{CC1} or V_{CC2}), the RDY pin output goes low; otherwise, RDY pin output is high. RDY pin also serves as an indication to the micro-controller that the device is ready for operation.

9.3.4 Soft Turnoff, Fault (\overline{FLT}) and Reset (\overline{RST})

During IGBT overcurrent condition, a mute logic initiates a soft-turn-off procedure which disables, OUTH, and pulls OUTL to low over a time span of 2 μ s. When desaturation is active, a fault signal is sent across the isolation barrier pulling the \overline{FLT} output at the input side low and blocking the isolator input. mute logic is activated through the soft-turn-off period. The \overline{FLT} output condition is latched and can be reset only after RDY goes high, through a active-low pulse at the \overline{RST} input. \overline{RST} has an internal filter to reject noise and glitches. By asserting \overline{RST} for at least the specified minimum duration (800 ns), device input logic can be enabled or disabled.

9.3.5 Short Circuit Clamp

Under short circuit events it is possible that currents are induced back into the gate-driver OUTH/L and CLAMP pins due to parasitic Miller capacitance between the IGBT collector and gate terminals. Internal protection diodes on OUTH/L and CLAMP help to sink these currents while clamping the voltages on these pins to values slightly higher than the output side supply.

9.4 Device Functional Modes

In ISO5852S-Q1 OUTH/L to follow IN+ in normal functional mode, $\overline{\text{FLT}}$ pin must be in the high state. Table 1 lists the device functions.

Table 1. Function Table⁽¹⁾

V_{CC1}	V_{CC2}	IN+	IN–	$\overline{\text{RST}}$	RDY	OUTH/L
PU	PD	X	X	X	Low	Low
PD	PU	X	X	X	Low	Low
PU	PU	X	X	Low	High	Low
PU	Open	X	X	X	Low	Low
PU	PU	Low	X	X	High	Low
PU	PU	X	High	X	High	Low
PU	PU	High	Low	High	High	High

(1) PU: Power Up ($V_{CC1} \geq 2.25\text{ V}$, $V_{CC2} \geq 13\text{ V}$), PD: Power Down ($V_{CC1} \leq 1.7\text{ V}$, $V_{CC2} \leq 9.5\text{ V}$), X: Irrelevant

10 Application and Implementation

NOTE

Information in the following applications sections is not part of the TI component specification, and TI does not warrant its accuracy or completeness. TI's customers are responsible for determining suitability of components for their purposes. Customers should validate and test their design implementation to confirm system functionality.

10.1 Application Information

The ISO5852S-Q1 device is an isolated gate driver for power semiconductor devices such as IGBTs and MOSFETs. It is intended for use in applications such as motor control, industrial inverters and switched mode power supplies. In these applications, sophisticated PWM control signals are required to turn the power devices on and off, which at the system level eventually may determine, for example, the speed, position, and torque of the motor or the output voltage, frequency and phase of the inverter. These control signals are usually the outputs of a microcontroller, and are at low voltage levels such as 2.5 V, 3.3 V or 5 V. The gate controls required by the MOSFETs and IGBTs, however, are in the range of 30-V (using unipolar output supply) to 15-V (using bipolar output supply), and require high-current capability to drive the large capacitive loads offered by those power transistors. The gate drive must also be applied with reference to the emitter of the IGBT (source for MOSFET), and by construction, the emitter node in a gate-drive system may swing between 0 to the DC-bus voltage, which can be several 100s of volts in magnitude.

The ISO5852S-Q1 device is therefore used to level shift the incoming 2.5-V, 3.3-V, and 5-V control signals from the microcontroller to the 30-V (using unipolar output supply) to 15-V (using bipolar output supply) drive required by the power transistors while ensuring high-voltage isolation between the driver side and the microcontroller side.

10.2 Typical Applications

Figure 48 shows the typical application of a three-phase inverter using six ISO5852S-Q1 isolated gate drivers. Three-phase inverters are used for variable-frequency drives to control the operating speed and torque of AC motors and for high-power applications such as high-voltage DC (HVDC) power transmission.

The basic three-phase inverter consists of six power switches, and each switch is driven by one ISO5852S-Q1. The switches are driven on and off at high switching frequency with specific patterns that to converter dc bus voltage to three-phase AC voltages.

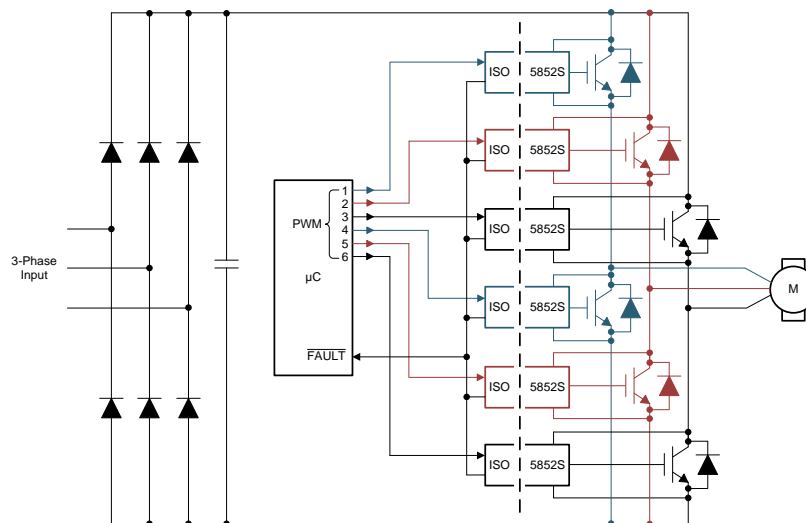

Figure 48. Typical Motor-Drive Application

Typical Applications (continued)

10.2.1 Design Requirements

Unlike optocoupler-based gate drivers which required external current drivers and biasing circuitry to provide the input control signals, the input control to the ISO5852S-Q1 device is CMOS and can be directly driven by the microcontroller. Other design requirements include decoupling capacitors on the input and output supplies, a pullup resistor on the common-drain FLT output signal and RST input signal, and a high-voltage protection diode between the IGBT collector and the DESAT input. Further details are explained in the subsequent sections. Table 2 lists the allowed range for input and output supply voltage, and the typical current output available from the gate-driver.

Table 2. Design Parameters

PARAMETER	VALUE
Input supply voltage	2.25 V to 5.5 V
Unipolar output-supply voltage ($V_{CC2} - GND2 = V_{CC2} - V_{EE2}$)	15 V to 30 V
Bipolar output-supply voltage ($V_{CC2} - V_{EE2}$)	15 V to 30 V
Bipolar output-supply voltage ($GND2 - V_{EE2}$)	0 V to 15 V
Output current	2.5 A

10.2.2 Detailed Design Procedure

10.2.2.1 Recommended ISO5852S-Q1 Application Circuit

The ISO5852S-Q1 device has both, inverting and noninverting gate-control inputs, an active-low reset input, and an open-drain fault output suitable for wired-OR applications. The recommended application circuit in Figure 49 shows a typical gate-driver implementation with unipolar output supply. Figure 50 shows a typical gate-driver implementation with bipolar output supply using the ISO5852S-Q1 device.

A 0.1- μ F bypass capacitor, recommended at the input supply pin V_{CC1} , and 1- μ F bypass capacitor, recommended at the V_{CC2} output supply pin, provide the large transient currents required during a switching transition to ensure reliable operation. The 220-pF blanking capacitor disables DESAT detection during the off-to-on transition of the power device. The DESAT diode (D_{DST}) and the 1-k Ω series resistor on the DESAT pin are external protection components. The R_G gate resistor limits the gate-charge current and indirectly controls the rise and fall times of the IGBT collector voltage. The open-drain FLT output and RDY output have a passive 10-k Ω pullup resistor. In this application, the IGBT gate driver is disabled when a fault is detected and does not resume switching until the microcontroller applies a reset signal.

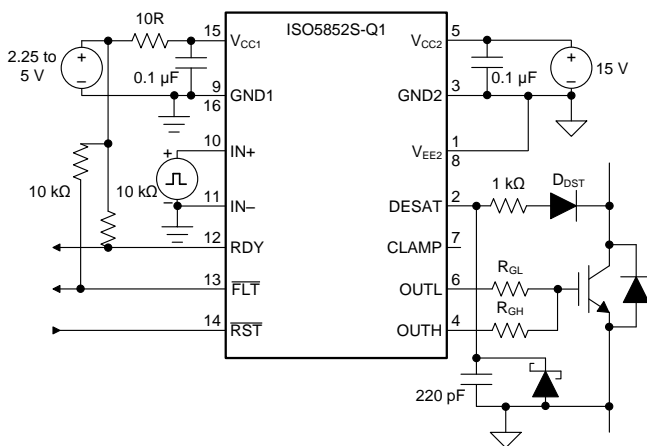

Copyright © 2016, Texas Instruments Incorporated

Figure 49. Unipolar Output Supply

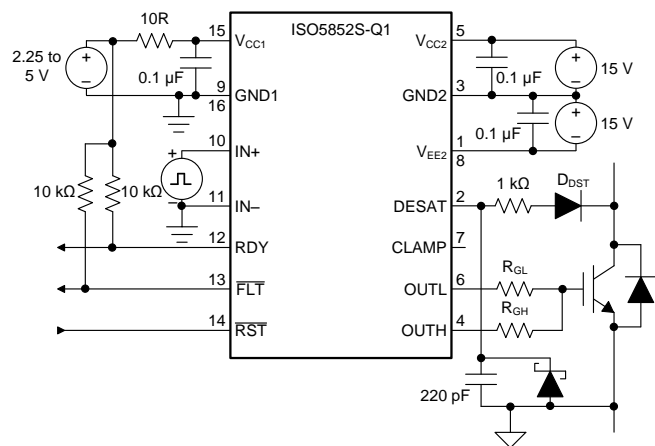

Copyright © 2016, Texas Instruments Incorporated

Figure 50. Bipolar Output Supply

10.2.2.2 \overline{FLT} and RDY Pin Circuitry

A 50-k Ω pullup resistor exists internally on \overline{FLT} and RDY pins. The \overline{FLT} and RDY pins are an open-drain output. A 10-k Ω pullup resistor can be used to make it faster rise and to provide logic high when \overline{FLT} and RDY is inactive, as shown in Figure 51.

Fast common-mode transients can inject noise and glitches on \overline{FLT} and RDY pins because of parasitic coupling. The injection of noise and glitches is dependent on board layout. If required, additional capacitance (100 pF to 300 pF) can be included on the \overline{FLT} and RDY pins.

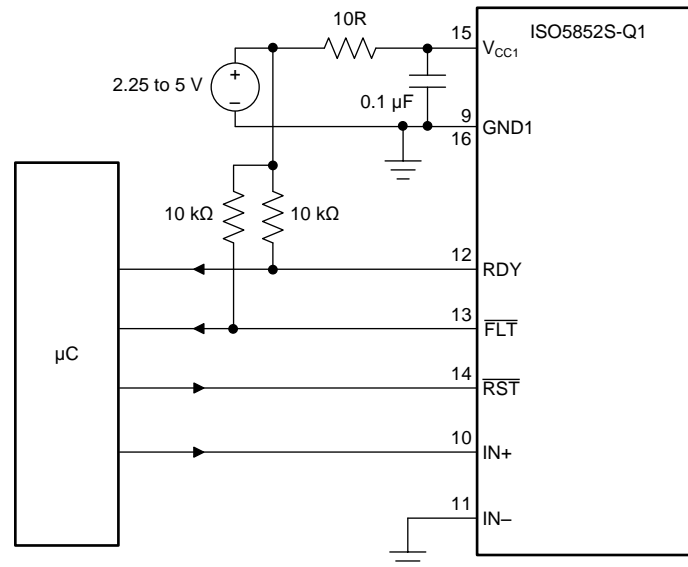

Copyright © 2016, Texas Instruments Incorporated

Figure 51. \overline{FLT} and RDY Pin Circuitry for High CMTI

10.2.2.3 Driving the Control Inputs

The amount of common-mode transient immunity (CMTI) can be curtailed by the capacitive coupling from the high-voltage output circuit to the low-voltage input side of the ISO5852S-Q1 device. For maximum CMTI performance, the digital control inputs, IN+ and IN–, must be actively driven by standard CMOS, push-pull drive circuits. This type of low-impedance signal source provides active drive signals that prevent unwanted switching of the ISO5852S-Q1 output under extreme common-mode transient conditions. Passive drive circuits, such as open-drain configurations using pullup resistors, must be avoided. A 20-ns glitch filter exists that can filter a glitch up to 20 ns on IN+ or IN–.

10.2.2.4 Local Shutdown and Reset

In applications with local shutdown and reset, the $\overline{\text{FLT}}$ output of each gate driver is polled separately, and the individual reset lines are independently asserted low to reset the motor controller after a fault condition.

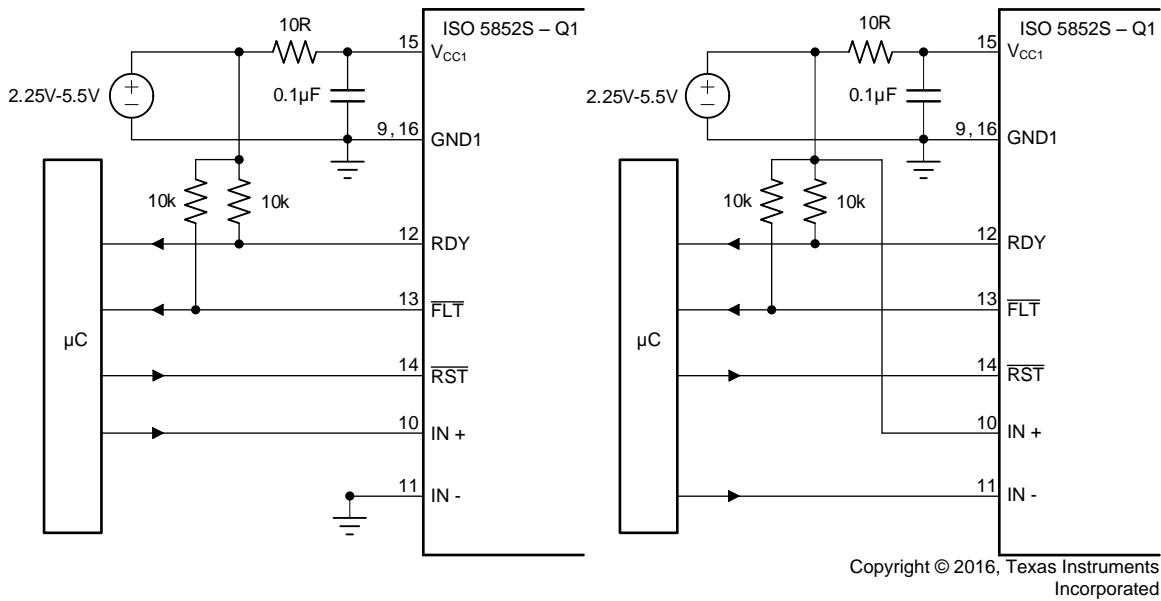

Figure 52. Local Shutdown and Reset for Noninverting (left) and Inverting Input Configuration (right)

10.2.2.5 Global-Shutdown and Reset

When configured for inverting operation, the ISO5852S-Q1 device can be configured to shutdown automatically in the event of a fault condition by tying the FLT output to IN+. For high reliability drives, the open drain FLT outputs of multiple ISO5852S-Q1 devices can be wired together forming a single, common fault bus for interfacing directly to the microcontroller. When any of the six gate drivers of a three-phase inverter detects a fault, the active-low $\overline{\text{FLT}}$ output disables all six gate drivers simultaneously.

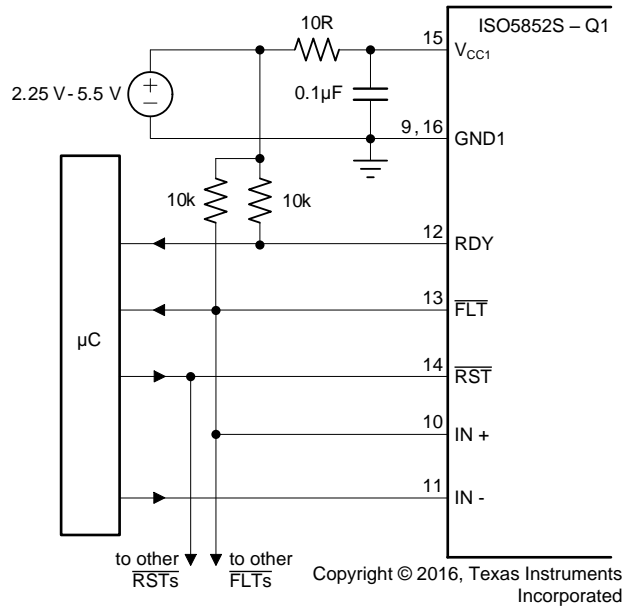

Figure 53. Global Shutdown With Inverting Input Configuration

10.2.2.6 Auto-Reset

In this case, the gate control signal at IN+ is also applied to the $\overline{\text{RST}}$ input to reset the fault latch every switching cycle. Incorrect RST makes output go low. A fault condition, however, the gate driver remains in the latched fault state until the gate control signal changes to the *gate-low* state and resets the fault latch.

If the gate control signal is a continuous PWM signal, the fault latch is always reset before IN+ goes high again. This configuration protects the IGBT on a cycle-by-cycle basis and automatically resets before the next *on* cycle.

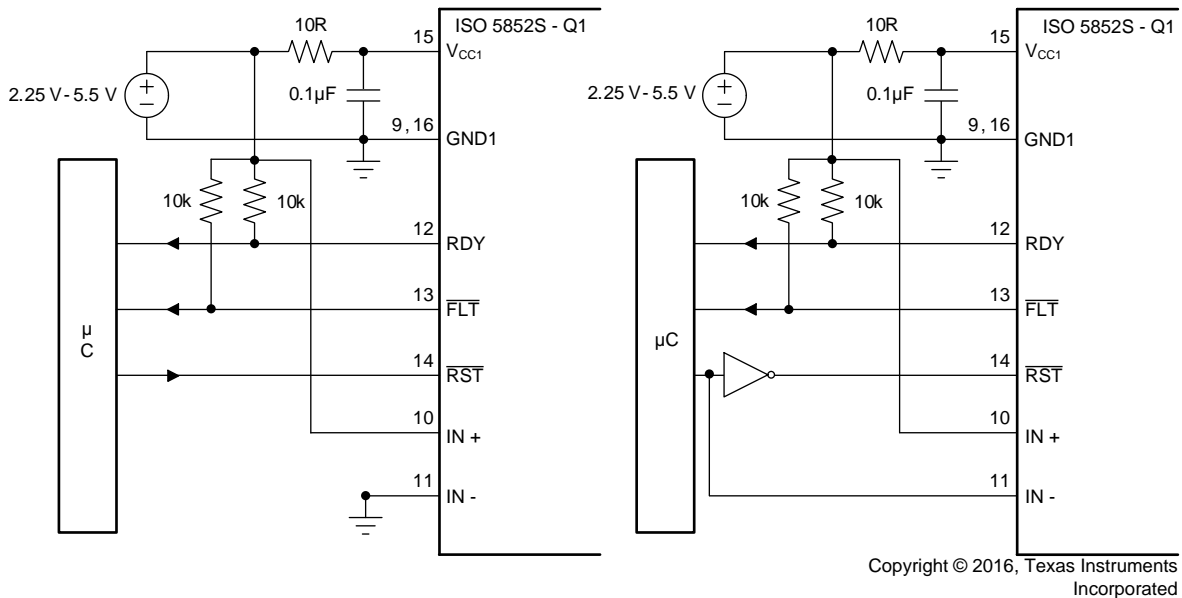

Figure 54. Auto Reset for Noninverting and Inverting Input Configuration

10.2.2.7 DESAT Pin Protection

Switching inductive loads causes large, instantaneous forward-voltage transients across the freewheeling diodes of the IGBTs. These transients result in large negative-voltage spikes on the DESAT pin which draw substantial current out of the device. To limit this current below damaging levels, a 100- Ω to 1-k Ω resistor is connected in series with the DESAT diode.

Further protection is possible through an optional Schottky diode, whose low-forward voltage assures clamping of the DESAT input to GND2 potential at low-voltage levels.

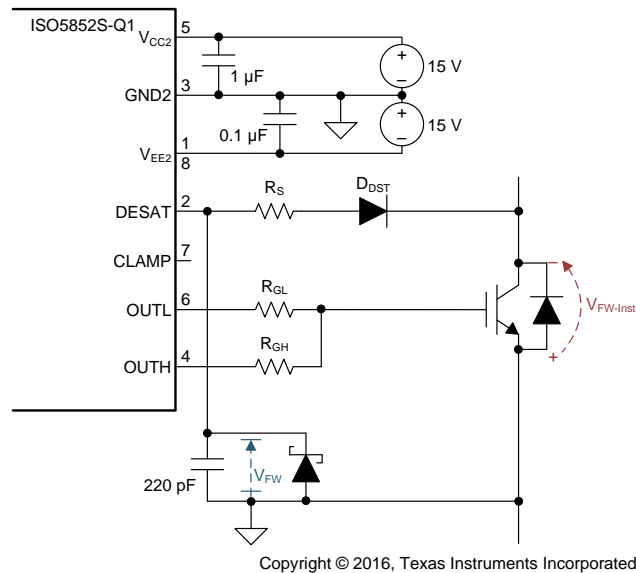

Figure 55. DESAT Pin Protection With Series Resistor and Schottky Diode

10.2.2.8 DESAT Diode and DESAT Threshold

The function of the DESAT diode is to conduct forward current, allowing sensing of the saturated collector-to-emitter voltage of the IGBT, $V_{(DESAT)}$, (when the IGBT is *on*), and to block high voltages (when the IGBT is *off*). During the short transition time when the IGBT is switching, a commonly high dV_{CE}/dt voltage ramp rate occurs across the IGBT. This ramp rate results in a charging current $I_{(CHARGE)} = C_{(D-DESAT)} \times dV_{CE}/dt$, charging the blanking capacitor. $C_{(D-DESAT)}$ is the diode capacitance at DESAT.

To minimize this current and avoid false DESAT triggering, fast switching diodes with low capacitance are recommended. As the diode capacitance builds a voltage divider with the blanking capacitor, large collector voltage transients appear at DESAT attenuated by the ratio of $1 + C_{(BLANK)} / C_{(D-DESAT)}$.

Because the sum of the DESAT diode forward-voltage and the IGBT collector-emitter voltage make up the voltage at the DESAT-pin, $V_F + V_{CE} = V_{(DESAT)}$, the V_{CE} level, which triggers a fault condition, can be modified by adding multiple DESAT diodes in series: $V_{CE-FAULT(TH)} = 9\text{ V} - n \times VF$ (where n is the number of DESAT diodes).

When using two diodes instead of one, diodes with half the required maximum reverse-voltage rating can be selected.

10.2.2.9 Determining the Maximum Available, Dynamic Output Power, P_{OD-max}

The ISO5852S-Q1 maximum-allowed total power consumption of $P_D = 251\text{ mW}$ consists of the total input power, P_{ID} , the total output power, P_{OD} , and the output power under load, P_{OL} :

$$P_D = P_{ID} + P_{OD} + P_{OL} \quad (1)$$

With:

$$P_{ID} = V_{CC1-max} \times I_{CC1-max} = 5.5\text{ V} \times 4.5\text{ mA} = 24.75\text{ mW} \quad (2)$$

and:

$$P_{OD} = (V_{CC2} - V_{EE2}) \times I_{CC2-max} = (15\text{ V} - [-8\text{ V}]) \times 6\text{ mA} = 138\text{ mW} \quad (3)$$

then:

$$P_{OL} = P_D - P_{ID} - P_{OD} = 251\text{ mW} - 24.75\text{ mW} - 138\text{ mW} = 88.25\text{ mW} \quad (4)$$

In comparison to P_{OL} , the actual dynamic output power under worst case condition, P_{OL-WC} , depends on a variety of parameters:

$$P_{OL-WC} = 0.5 \times f_{INP} \times Q_G \times (V_{CC2} - V_{EE2}) \times \left(\frac{r_{on-max}}{r_{on-max} + R_G} + \frac{r_{off-max}}{r_{off-max} + R_G} \right)$$

where

- f_{INP} = signal frequency at the control input IN+
- Q_G = power device gate charge
- V_{CC2} = positive output supply with respect to GND2
- V_{EE2} = negative output supply with respect to GND2
- r_{on-max} = worst case output resistance in the on-state: 4 Ω
- $r_{off-max}$ = worst case output resistance in the off-state: 2.5 Ω
- R_G = gate resistor

(5)

When R_G is determined, Equation 5 is to be used to verify whether $P_{OL-WC} < P_{OL}$. Figure 56 shows a simplified output stage model for calculating P_{OL-WC} .

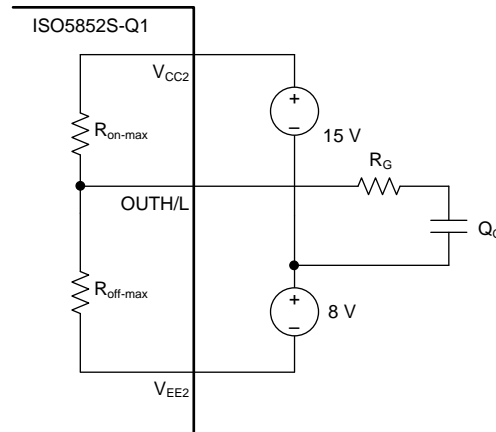

Copyright © 2016, Texas Instruments Incorporated

Figure 56. Simplified Output Model for Calculating P_{OL-WC}

10.2.2.10 Example

This examples considers an IGBT drive with the following parameters:

- $I_{ON-PK} = 2 \text{ A}$
- $Q_G = 650 \text{ nC}$
- $f_{INP} = 20 \text{ kHz}$
- $V_{CC2} = 15 \text{ V}$
- $V_{EE2} = -8 \text{ V}$

Applying the value of the gate resistor $R_G = 10 \Omega$.

Then, calculating the worst-case output-power consumption as a function of R_G , using Equation 5 r_{on-max} = worst case output resistance in the on-state: 4Ω , $r_{off-max}$ = worst case output resistance in the off-state: 2.5Ω , R_G = gate resistor yields

$$P_{OL-WC} = 0.5 \times 20 \text{ kHz} \times 650 \text{ nC} \times (15 \text{ V} - (-8 \text{ V})) \times \left(\frac{4 \Omega}{4 \Omega + 10 \Omega} + \frac{2.5 \Omega}{2.5 \Omega + 10 \Omega} \right) = 72.61 \text{ mW} \quad (6)$$

Because $P_{OL-WC} = 72.61 \text{ mW}$ is less than the calculated maximum of $P_{OL} = 88.25 \text{ mW}$, the resistor value of $R_G = 10 \Omega$ is suitable for this application.

10.2.2.11 Higher Output Current Using an External Current Buffer

To increase the IGBT gate drive current, a non-inverting current buffer (such as the npn/pnp buffer shown in Figure 57) can be used. Inverting types are not compatible with the desaturation fault protection circuitry and must be avoided. The MJD44H11/MJD45H11 pair is appropriate for currents up to 8 A, the D44VH10/ D45VH10 pair for up to 15 A maximum.

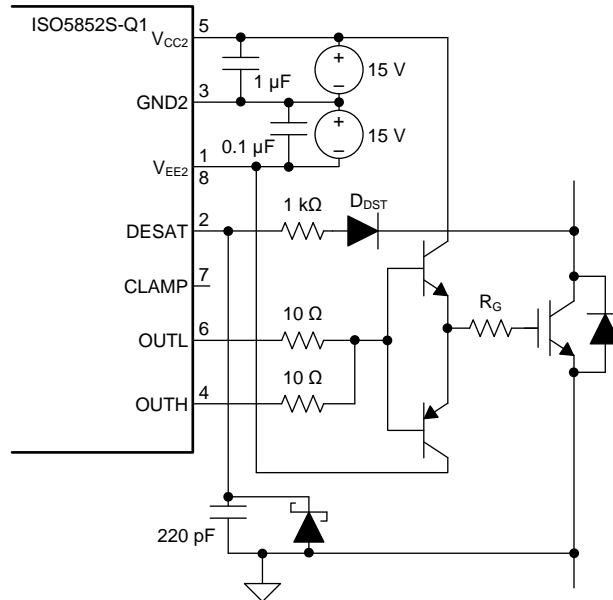

Copyright © 2016, Texas Instruments Incorporated

Figure 57. Current Buffer for Increased Drive Current

10.2.3 Application Curves

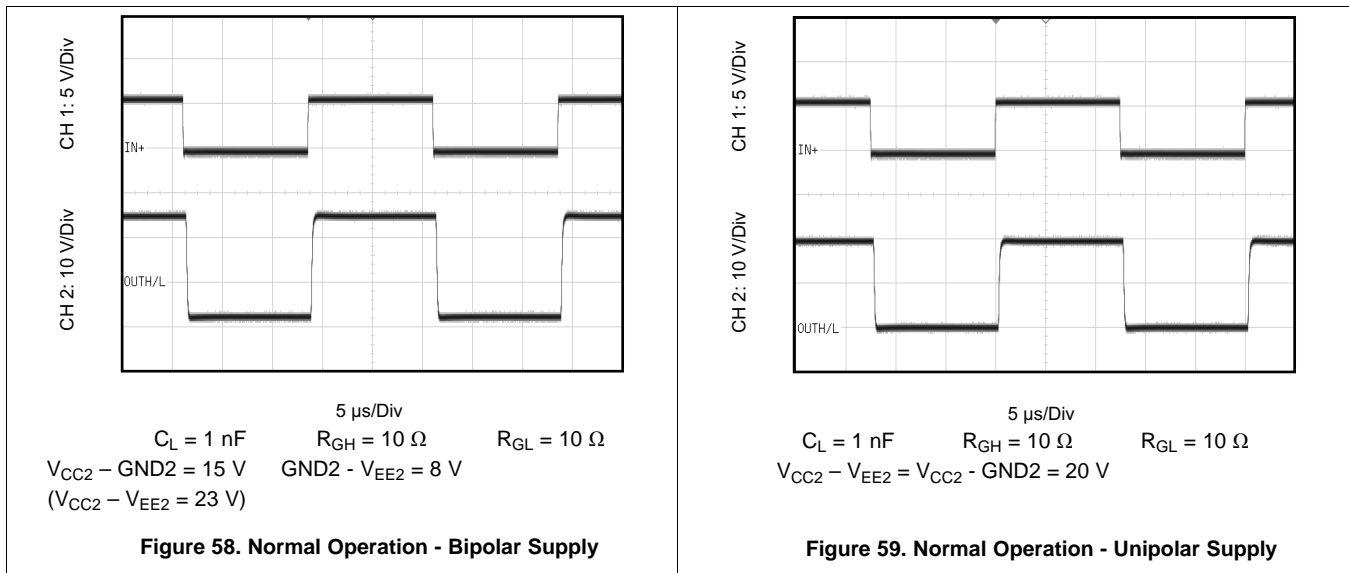

11 Power Supply Recommendations

To help ensure reliable operation at all data rates and supply voltages, a 0.1- μF bypass capacitor is recommended at the V_{CC1} input supply pin and a 1- μF bypass capacitor is recommended at the V_{CC2} output supply pin. The capacitors should be placed as close to the supply pins as possible. The recommended placement of the capacitors is 2 mm (maximum) from the input and output power supply pins (V_{CC1} and V_{CC2}).

12 Layout

12.1 Layout Guidelines

minimum of four layers is required to accomplish a low EMI PCB design (see [Figure 60](#)). Layer stacking should be in the following order (top-to-bottom): high-speed signal layer, ground plane, power plane and low-frequency signal layer.

- Routing the high-current or sensitive traces on the top layer avoids the use of vias (and the introduction of their inductances) and allows for clean interconnects between the gate driver and the microcontroller and power transistors. Gate driver control input, Gate driver output OUTH/L and DESAT should be routed in the top layer.
- Placing a solid ground plane next to the sensitive signal layer provides an excellent low-inductance path for the return current flow. On the driver side, use GND2 as the ground plane.
- Placing the power plane next to the ground plane creates additional high-frequency bypass capacitance of approximately 100 pF/inch². On the gate-driver V_{EE2} and V_{CC2} can be used as power planes. They can share the same layer on the PCB as long as they are not connected together.
- Routing the slower speed control signals on the bottom layer allows for greater flexibility as these signal links usually have margin to tolerate discontinuities such as vias.

For more detailed layout recommendations, including placement of capacitors, impact of vias, reference planes, routing, and other details, see the [Digital Isolator Design Guide](#).

12.2 PCB Material

For digital circuit boards operating at less than 150 Mbps, (or rise and fall times greater than 1 ns), and trace lengths of up to 10 inches, use standard FR-4 UL94V-0 printed circuit board. This PCB is preferred over cheaper alternatives because of lower dielectric losses at high frequencies, less moisture absorption, greater strength and stiffness, and the self-extinguishing flammability-characteristics.

12.3 Layout Example

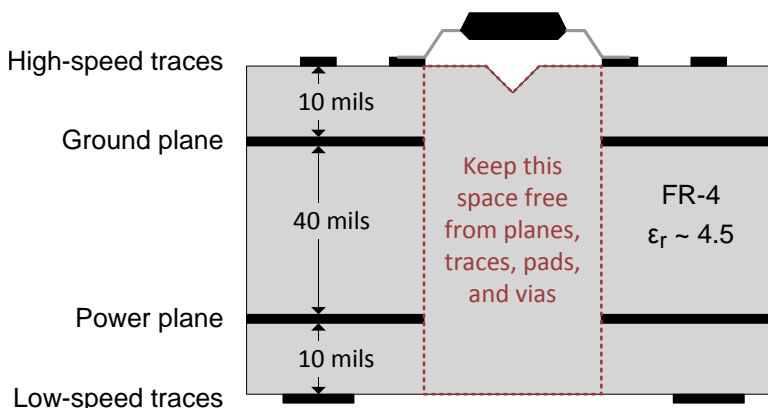

Figure 60. Recommended Layer Stack

13 器件和文档支持

13.1 文档支持

13.1.1 相关文档

相关文档如下：

- [数字隔离器设计指南](#)
- [《ISO5852S 评估模块 \(EVM\) 用户指南》](#)
- [隔离相关术语](#)

13.2 接收文档更新通知

要接收文档更新通知，请访问 www.ti.com.cn 您器件对应的产品文件夹。点击右上角的提醒我 (*Alert me*) 注册后，即可每周定期收到已更改的产品信息。有关更改的详细信息，请查阅已修订文档的修订历史记录。

13.3 社区资源

The following links connect to TI community resources. Linked contents are provided "AS IS" by the respective contributors. They do not constitute TI specifications and do not necessarily reflect TI's views; see TI's [Terms of Use](#).

TI E2E™ Online Community *TI's Engineer-to-Engineer (E2E) Community*. Created to foster collaboration among engineers. At e2e.ti.com, you can ask questions, share knowledge, explore ideas and help solve problems with fellow engineers.

Design Support *TI's Design Support* Quickly find helpful E2E forums along with design support tools and contact information for technical support.

13.4 商标

E2E is a trademark of Texas Instruments.

All other trademarks are the property of their respective owners.

13.5 静电放电警告



这些装置包含有限的内置 ESD 保护。存储或装卸时，应将导线一起截短或将装置放置于导电泡棉中，以防止 MOS 门极遭受静电损伤。

13.6 Glossary

[SLYZ022](#) — *TI Glossary*.

This glossary lists and explains terms, acronyms, and definitions.

14 机械、封装和可订购信息

以下页中包括机械、封装和可订购信息。这些信息是针对指定器件可提供的最新数据。这些数据会在无通知且不对本文档进行修订的情况下发生改变。欲获得该数据表的浏览器版本，请查阅左侧的导航栏。

PACKAGE OUTLINE

DW0016B
SOIC - 2.65 mm max height

SOIC

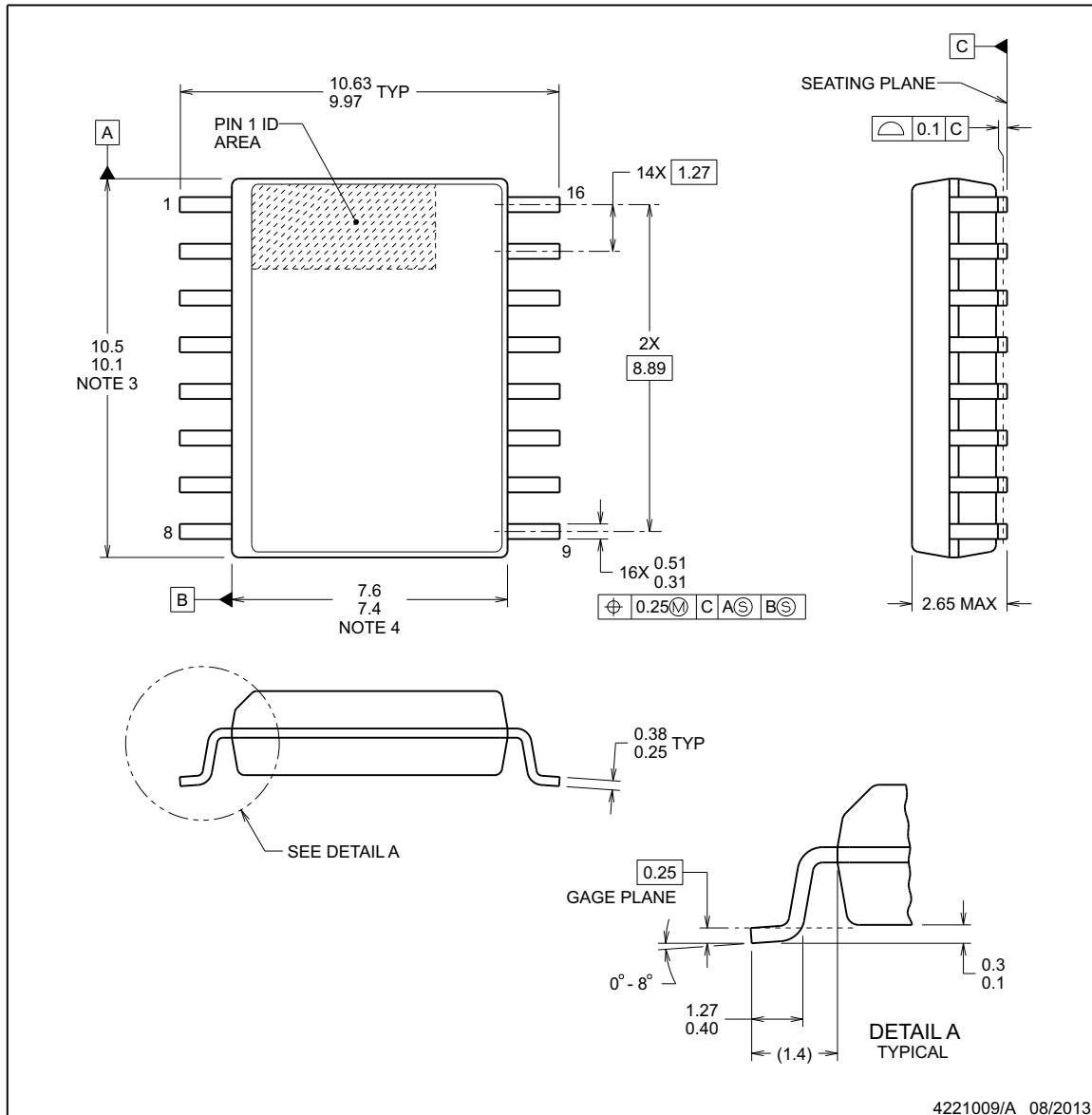
NOTES:

1. All linear dimensions are in millimeters. Dimensions in parenthesis are for reference only. Dimensioning and tolerancing per ASME Y14.5M.
2. This drawing is subject to change without notice.
3. This dimension does not include mold flash, protrusions, or gate burrs. Mold flash, protrusions, or gate burrs shall not exceed 0.15 mm, per side.
4. This dimension does not include interlead flash. Interlead flash shall not exceed 0.25 mm, per side.
5. Reference JEDEC registration MO-013, variation AA.

EXAMPLE BOARD LAYOUT

DW0016B

SOIC - 2.65 mm max height

SOIC

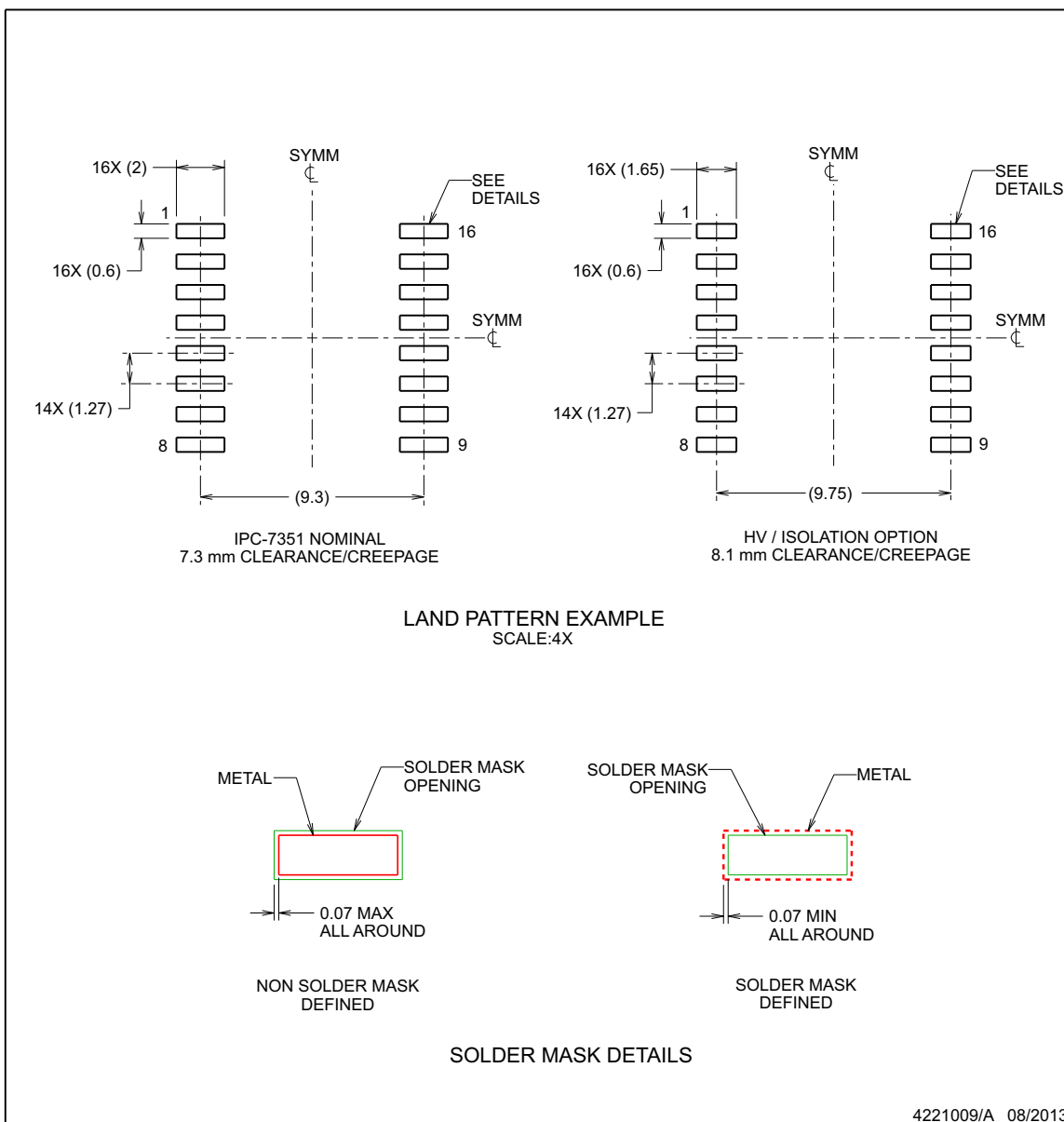

NOTES: (continued)

6. Publication IPC-7351 may have alternate designs.
7. Solder mask tolerances between and around signal pads can vary based on board fabrication site.

EXAMPLE STENCIL DESIGN

DW0016B

SOIC - 2.65 mm max height

SOIC

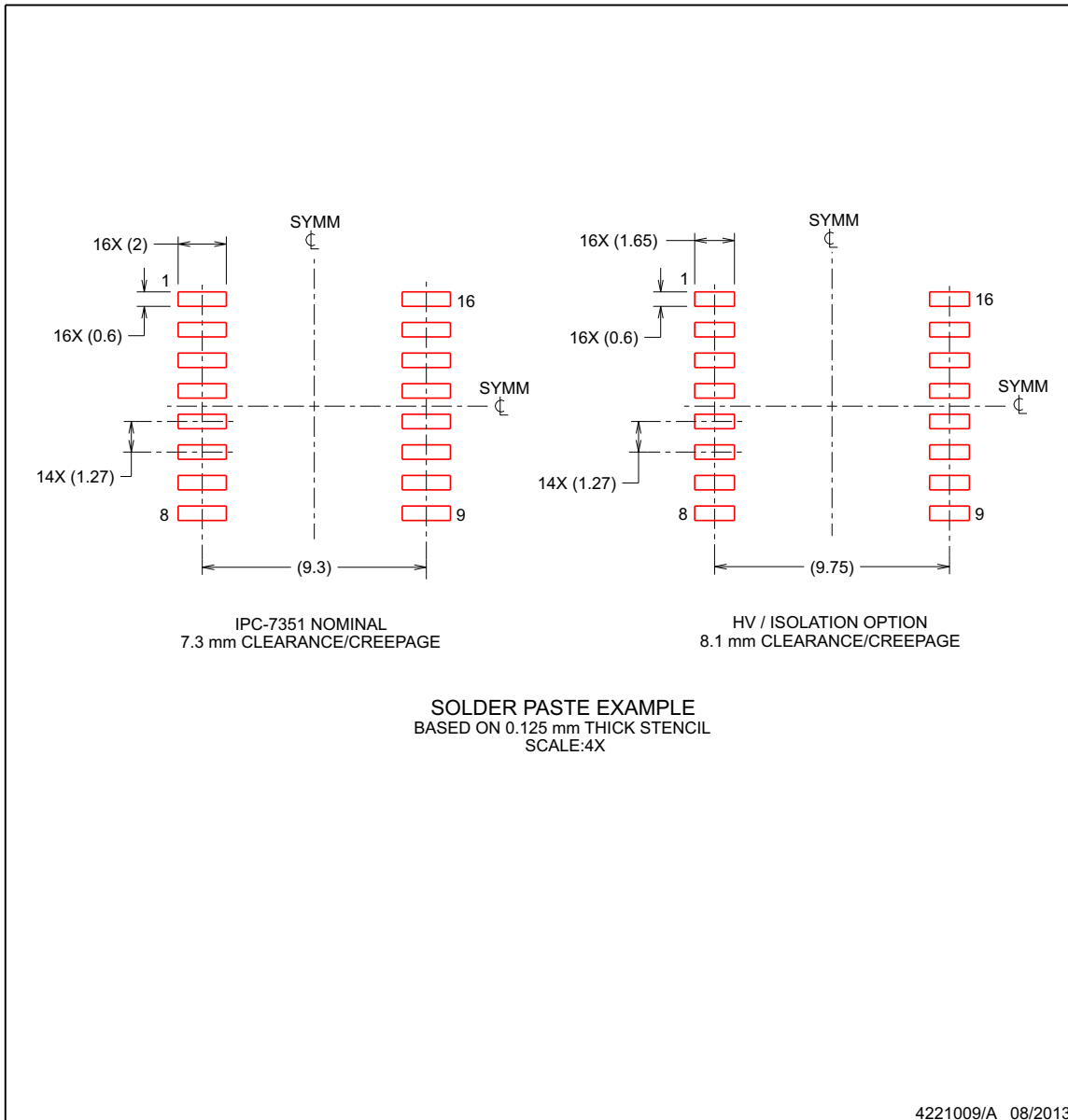

NOTES: (continued)

- 8. Laser cutting apertures with trapezoidal walls and rounded corners may offer better paste release. IPC-7525 may have alternate design recommendations.
- 9. Board assembly site may have different recommendations for stencil design.

重要声明

德州仪器(TI)及其下属子公司有权根据 JESD46 最新标准,对所提供的产品和服务进行更正、修改、增强、改进或其它更改,并有权根据 JESD48 最新标准中止提供任何产品和服务。客户在下订单前应获取最新的相关信息,并验证这些信息是否完整且是最新的。所有产品的销售都遵循在订单确认时所提供的TI 销售条款与条件。

TI 保证其所销售的组件的性能符合产品销售时 TI 半导体产品销售条件与条款的适用规范。仅在 TI 保证的范围内,且 TI 认为有必要时才会使用测试或其它质量控制技术。除非适用法律做出了硬性规定,否则没有必要对每种组件的所有参数进行测试。

TI 对应用帮助或客户产品设计不承担任何义务。客户应对其使用 TI 组件的产品和应用自行负责。为尽量减小与客户产品和应用相关的风险,客户应提供充分的设计与操作安全措施。

TI 不对任何 TI 专利权、版权、屏蔽作品权或其它与使用了 TI 组件或服务的组合设备、机器或流程相关的 TI 知识产权中授予的直接或隐含权限作出任何保证或解释。TI 所发布的与第三方产品或服务有关的信息,不能构成从 TI 获得使用这些产品或服务的许可、授权、或认可。使用此类信息可能需要获得第三方的专利权或其它知识产权方面的许可,或是 TI 的专利权或其它知识产权方面的许可。

对于 TI 的产品手册或数据表中 TI 信息的重要部分,仅在没有对内容进行任何篡改且带有相关授权、条件、限制和声明的情况下才允许进行复制。TI 对此类篡改过的文件不承担任何责任或义务。复制第三方的信息可能需要服从额外的限制条件。

在转售 TI 组件或服务时,如果对该组件或服务参数的陈述与 TI 标明的参数相比存在差异或虚假成分,则会失去相关 TI 组件或服务的所有明示或暗示授权,且这是不正当的、欺诈性商业行为。TI 对任何此类虚假陈述均不承担任何责任或义务。

客户认可并同意,尽管任何应用相关信息或支持仍可能由 TI 提供,但他们将独立负责满足与其产品及其在应用中使用的 TI 产品相关的所有法律、法规和安全相关要求。客户声明并同意,他们具备制定与实施安全措施所需的全部专业技术和知识,可预见故障的危险后果、监测故障及其后果、降低有可能造成人身伤害的故障的发生机率并采取适当的补救措施。客户将全额赔偿因在此类安全关键应用中使用任何 TI 组件而对 TI 及其代理造成的任何损失。

在某些场合中,为了推进安全相关应用有可能对 TI 组件进行特别的促销。TI 的目标是利用此类组件帮助客户设计和创立其特有的可满足适用的功能安全性标准和要求的终端产品解决方案。尽管如此,此类组件仍然服从这些条款。

TI 组件未获得用于 FDA Class III (或类似的生命攸关医疗设备)的授权许可,除非各方授权官员已经达成了专门管控此类使用的特别协议。

只有那些 TI 特别注明属于军用等级或“增强型塑料”的 TI 组件才是设计或专门用于军事/航空应用或环境的。购买者认可并同意,对并非指定面向军事或航空航天用途的 TI 组件进行军事或航空航天方面的应用,其风险由客户单独承担,并且由客户独立负责满足与此类使用相关的所有法律和法规要求。

TI 已明确指定符合 ISO/TS16949 要求的产品,这些产品主要用于汽车。在任何情况下,因使用非指定产品而无法达到 ISO/TS16949 要求, TI 不承担任何责任。

	产品		应用
数字音频	www.ti.com.cn/audio	通信与电信	www.ti.com.cn/telecom
放大器和线性器件	www.ti.com.cn/amplifiers	计算机及周边	www.ti.com.cn/computer
数据转换器	www.ti.com.cn/dataconverters	消费电子	www.ti.com.cn/consumer-apps
DLP® 产品	www.dlp.com	能源	www.ti.com.cn/energy
DSP - 数字信号处理器	www.ti.com.cn/dsp	工业应用	www.ti.com.cn/industrial
时钟和计时器	www.ti.com.cn/clockandtimers	医疗电子	www.ti.com.cn/medical
接口	www.ti.com.cn/interface	安防应用	www.ti.com.cn/security
逻辑	www.ti.com.cn/logic	汽车电子	www.ti.com.cn/automotive
电源管理	www.ti.com.cn/power	视频和影像	www.ti.com.cn/video
微控制器 (MCU)	www.ti.com.cn/microcontrollers		
RFID 系统	www.ti.com.cn/rfidsys		
OMAP应用处理器	www.ti.com/omap		
无线连通性	www.ti.com.cn/wirelessconnectivity	德州仪器在线技术支持社区	www.deyisupport.com

邮寄地址: 上海市浦东新区世纪大道1568号, 中建大厦32楼邮政编码: 200122
Copyright © 2016, 德州仪器半导体技术(上海)有限公司

PACKAGING INFORMATION

Orderable Device	Status (1)	Package Type	Package Drawing	Pins	Package Qty	Eco Plan (2)	Lead finish/ Ball material (6)	MSL Peak Temp (3)	Op Temp (°C)	Device Marking (4/5)	Samples
ISO5852SQDWQ1	ACTIVE	SOIC	DW	16	40	RoHS & Green	NIPDAU	Level-2-260C-1 YEAR	-40 to 125	ISO5852SQ	Samples
ISO5852SQDWRQ1	ACTIVE	SOIC	DW	16	2000	RoHS & Green	NIPDAU	Level-2-260C-1 YEAR	-40 to 125	ISO5852SQ	Samples

(1) The marketing status values are defined as follows:

ACTIVE: Product device recommended for new designs.

LIFEBUY: TI has announced that the device will be discontinued, and a lifetime-buy period is in effect.

NRND: Not recommended for new designs. Device is in production to support existing customers, but TI does not recommend using this part in a new design.

PREVIEW: Device has been announced but is not in production. Samples may or may not be available.

OBSOLETE: TI has discontinued the production of the device.

(2) **RoHS:** TI defines "RoHS" to mean semiconductor products that are compliant with the current EU RoHS requirements for all 10 RoHS substances, including the requirement that RoHS substance do not exceed 0.1% by weight in homogeneous materials. Where designed to be soldered at high temperatures, "RoHS" products are suitable for use in specified lead-free processes. TI may reference these types of products as "Pb-Free".

RoHS Exempt: TI defines "RoHS Exempt" to mean products that contain lead but are compliant with EU RoHS pursuant to a specific EU RoHS exemption.

Green: TI defines "Green" to mean the content of Chlorine (Cl) and Bromine (Br) based flame retardants meet JS709B low halogen requirements of <=1000ppm threshold. Antimony trioxide based flame retardants must also meet the <=1000ppm threshold requirement.

(3) MSL, Peak Temp. - The Moisture Sensitivity Level rating according to the JEDEC industry standard classifications, and peak solder temperature.

(4) There may be additional marking, which relates to the logo, the lot trace code information, or the environmental category on the device.

(5) Multiple Device Markings will be inside parentheses. Only one Device Marking contained in parentheses and separated by a "~" will appear on a device. If a line is indented then it is a continuation of the previous line and the two combined represent the entire Device Marking for that device.

(6) Lead finish/Ball material - Orderable Devices may have multiple material finish options. Finish options are separated by a vertical ruled line. Lead finish/Ball material values may wrap to two lines if the finish value exceeds the maximum column width.

Important Information and Disclaimer:The information provided on this page represents TI's knowledge and belief as of the date that it is provided. TI bases its knowledge and belief on information provided by third parties, and makes no representation or warranty as to the accuracy of such information. Efforts are underway to better integrate information from third parties. TI has taken and continues to take reasonable steps to provide representative and accurate information but may not have conducted destructive testing or chemical analysis on incoming materials and chemicals. TI and TI suppliers consider certain information to be proprietary, and thus CAS numbers and other limited information may not be available for release.

In no event shall TI's liability arising out of such information exceed the total purchase price of the TI part(s) at issue in this document sold by TI to Customer on an annual basis.

重要声明和免责声明

TI 均以“原样”提供技术性及其可靠性数据（包括数据表）、设计资源（包括参考设计）、应用或其他设计建议、网络工具、安全信息和其他资源，不保证其中不含任何瑕疵，且不做任何明示或暗示的担保，包括但不限于对适销性、适合某特定用途或不侵犯任何第三方知识产权的暗示担保。

所述资源可供专业开发人员应用TI 产品进行设计使用。您将对以下行为独自承担全部责任：(1) 针对您的应用选择合适的TI 产品；(2) 设计、验证并测试您的应用；(3) 确保您的应用满足相应标准以及任何其他安全、安保或其他要求。所述资源如有变更，恕不另行通知。TI 对您使用所述资源的授权仅限于开发资源所涉及TI 产品的相关应用。除此之外不得复制或展示所述资源，也不提供其它TI 或任何第三方的知识产权授权许可。如因使用所述资源而产生任何索赔、赔偿、成本、损失及债务等，TI 对此概不负责，并且您须赔偿由此对TI 及其代表造成的损害。

TI 所提供产品均受TI 的销售条款 (<http://www.ti.com.cn/zh-cn/legal/termsofsale.html>) 以及ti.com.cn上或随附TI产品提供的其他可适用条款的约束。TI提供所述资源并不扩展或以其他方式更改TI 针对TI 产品所发布的可适用的担保范围或担保免责声明。

邮寄地址：上海市浦东新区世纪大道 1568 号中建大厦 32 楼，邮政编码：200122
Copyright © 2020 德州仪器半导体技术（上海）有限公司