

ISO773x EMC 性能优异的增强型高速三通道数字隔离器

1 特性

- 100Mbps 数据传输速率
- 稳健可靠的隔离栅：
 - 1500V_{RMS} 工作电压下，可实现 100 年以上的预期使用寿命
 - 高达 5000V_{RMS} 隔离额定值
 - 高达 12.8kV 的浪涌能力
 - CMTI 典型值为 $\pm 100\text{kV}/\mu\text{s}$
- 宽电源范围：2.25V 至 5.5V
- 2.25V 至 5.5V 电平转换
- 默认输出高电平 (ISO773x) 和低电平 (ISO773xF) 选项
- 宽温度范围：-55°C 至 +125°C
- 低功耗，1Mbps 时每通道的电流典型值为 1.5mA
- 低传播延迟：典型值为 11ns（由 5V 电源供电）
- 优异的电磁兼容性 (EMC)
 - 系统级 ESD、EFT 和浪涌抗扰性
 - $\pm 8\text{kV}$ IEC 61000-4-2 跨隔离栅接触放电保护
 - 低辐射
- 宽体 SOIC (DW-16) 和 QSOP (DBQ-16) 封装选项
- 可用的汽车版本：ISO773x-Q1/ISO773x-Q1[™]
- 安全相关认证：
 - 符合 DIN V VDE V 0884-11:2017-01 标准的增强型绝缘
 - 符合 UL 1577 标准的 5000V_{RMS} (DW) 和 3000V_{RMS} (DBQ) 隔离额定值
 - CSA 组件验收通知 5A、IEC 60950-1 和 IEC 60601-1 终端设备标准
 - 符合 GB4943.1-2011 的 CQC 认证
 - 符合 EN 60950-1 和 EN 61010-1 的 TUV 认证
 - 所有认证均已完成

2 应用

- 工业自动化
- 电机控制
- 电源
- 光伏逆变器
- 医疗设备

3 说明

ISO773x 器件是高性能三通道数字隔离器，可提供符合 UL 1577 的 5000V_{RMS} (DW 封装) 和 3000V_{RMS} (DBQ 封装) 隔离额定值。

该系列器件具有符合 VDE、CSA、TUV 和 CQC 标准的增强型隔离额定值。

在隔离 CMOS 或 LVCMOS 数字 I/O 时，ISO773x 系列器件可提供高电磁抗扰度和低辐射，并具备低功耗特性。每条隔离通道的逻辑输入和输出缓冲器均由双电容二氧化硅 (SiO₂) 绝缘栅相隔离。该器件配有使能引脚，可用于将多主驱动应用中的相应输出置于高阻抗状态，也可用于降低功耗。

器件信息⁽¹⁾

器件型号	封装	封装尺寸 (标称值)
ISO7730	SOIC (DW)	10.30mm × 7.50mm
ISO7731	SSOP (DBQ)	4.90mm × 3.90mm

(1) 如需了解所有可用封装，请参阅数据表末尾的可订购产品附录。

简化原理图

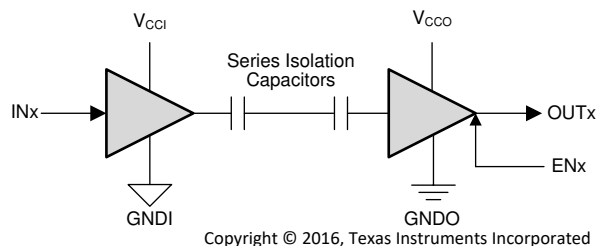

V_{CCI} = 输入电源，V_{CCO} = 输出电源
GNDI = 输入接地，GNDO = 输出接地

目录

1	特性	1	7.18	Insulation Characteristics Curves	15
2	应用	1	7.19	Typical Characteristics	16
3	说明	1	8	Parameter Measurement Information	18
4	修订历史记录	2	9	Detailed Description	20
5	说明 (续)	4	9.1	Overview	20
6	Pin Configuration and Functions	5	9.2	Functional Block Diagram	20
7	Specifications	6	9.3	Feature Description	21
7.1	Absolute Maximum Ratings	6	9.4	Device Functional Modes	22
7.2	ESD Ratings	6	10	Application and Implementation	23
7.3	Recommended Operating Conditions	6	10.1	Application Information	23
7.4	Thermal Information	7	10.2	Typical Application	23
7.5	Power Ratings	7	11	Power Supply Recommendations	27
7.6	Insulation Specifications	8	12	Layout	28
7.7	Safety-Related Certifications	9	12.1	Layout Guidelines	28
7.8	Safety Limiting Values	9	12.2	Layout Example	28
7.9	Electrical Characteristics—5-V Supply	10	13	器件和文档支持	29
7.10	Supply Current Characteristics—5-V Supply	10	13.1	文档支持	29
7.11	Electrical Characteristics—3.3-V Supply	11	13.2	相关链接	29
7.12	Supply Current Characteristics—3.3-V Supply	11	13.3	接收文档更新通知	29
7.13	Electrical Characteristics—2.5-V Supply	12	13.4	社区资源	29
7.14	Supply Current Characteristics—2.5-V Supply	12	13.5	商标	29
7.15	Switching Characteristics—5-V Supply	13	13.6	静电放电警告	29
7.16	Switching Characteristics—3.3-V Supply	14	13.7	Glossary	29
7.17	Switching Characteristics—2.5-V Supply	14	14	机械、封装和可订购信息	30

4 修订历史记录

注：之前版本的页码可能与当前版本有所不同。

Changes from Revision E (January 2018) to Revision F	Page
• 通篇进行了编辑性和修饰性更改	1
• 将特性中的“隔离栅寿命大于 40 年”更改为“1500V _{RMS} 工作电压下，可实现 100 年以上的预期使用寿命”	1
• 在特性中添加了“高达 5000V _{RMS} 隔离额定值”	1
• 在特性中添加了“高达 12.8kV 的浪涌能力”	1
• 在特性中添加了“±8kV IEC 61000-4-2 跨隔离栅接触放电保护”	1
• 在特性中添加了“可用的汽车版本：	1
• 在特性中更正了 DBQ 封装的 UL 1577 隔离额定值中的拼写错误，将“2500V _{RMS} ”更正为“3000V _{RMS} ”	1
• 在特性中将“除 DBQ-16 封装器件的 CQC 认证外，所有认证均已完成”更改为“所有认证均已完成”	1
• 更新了简化原理图，以显示每个通道的两个串联隔离电容，而不是单个隔离电容	1
• Added "Contact discharge per IEC 61000-4-2" specification of ±8000 V in ESD Ratings table	6
• Added the following table note to <i>Data rate</i> specification in Recommended Operating Conditions table: "100 Mbps is the maximum specified data rate, although higher data rates are possible."	6
• Changed V _{IORM} value for DW-16 package From: "1414 V _{PK} " To: "2121 V _{PK} " in Insulation Specifications table	8
• Changed V _{IOWM} value for DW-16 package AC voltage From: "1000 V _{RMS} " To: "1500 V _{RMS} " and DC voltage From: "1414 V _{DC} " To: "2121 V _{DC} " in Insulation Specifications table	8
• Added 'see Figure 27 ' to TEST CONDITIONS of V _{IOWM} specification in Insulation Specifications	8
• Changed V _{IOSM} TEST CONDITIONS From: "Test method per IEC 60065" To: "Test method per IEC 62368-1" in Insulation Specifications table	8
• Updated certification information in Safety-Related Certifications table	9
• Changed ground symbols for "Input (Devices with F suffix)" in Device I/O Schematics	22
• Added Insulation Lifetime sub-section under Application Curves section	26

修订历史记录 (接下页)

- 向 [文档支持](#) 部分添加了“.....” 29

Changes from Revision D (May 2017) to Revision E Page

- 已更改 通篇更改了了 DIN 认证编号和认证状态..... 1
- 已更改 将 DBQ 封装的隔离额定值从 $2500V_{RMS}$ 更改成了 $3000V_{RMS}$ 1
- Added V_{TEST} to the conditions for the maximum transient isolation voltage parameter in the *Insulation Specifications* table 8
- Changed the value for the DBQ package from 3600 V_{PK} to 4242 V_{PK} throughout the document..... 8
- Changed the method b1 V_{ini} condition for apparent charge in the *Insulation Specifications* table 8

Changes from Revision C (December 2016) to Revision D Page

- Updated the *Safety-Related Certifications* table..... 9
- Changed the minimum CMTI from 40 to 85 in all *Electrical Characteristics* tables 10

Changes from Revision B (October 2016) to Revision C Page

- Changed the *Regulatory Information* table to *Safety-Related Certifications* and updated content..... 9
- Changed the certifications from planned to certified in the *Safety-Related Certifications* table..... 9

Changes from Revision A (September 2016) to Revision B Page

- 将特性从“VDE 和 UL 认证...” 更改为“VDE、UL 和 TUV 认证...”..... 1
- Changed the unit value of CLR and CPG From: μm To: mm in *Insulation Specifications* 8
- Changed From: "according to VDE and UL;..." To: "according to VDE, UL, and TUV;..." in the conditions statement of *Safety-Related Certifications* 9
- Changed From: "Plan to certify" To: "Certified" in column TUV of *Safety-Related Certifications* 9
- Changed From: "Certification Planned" To: "Client ID number: 77311" in column TUV of *Safety-Related Certifications* 9

Changes from Original (September 2016) to Revision A Page

- Changed $V_{I(HYS)}$ MIN value From: $0.1 \times V_{CCO}$ To: $0.1 \times V_{CCI}$ in *Electrical Characteristics—5-V Supply*..... 10
- Changed $V_{I(HYS)}$ MIN value From: $0.1 \times V_{CCO}$ To: $0.1 \times V_{CCI}$ in *Electrical Characteristics—3.3-V Supply*..... 11
- Changed $V_{I(HYS)}$ MIN value From: $0.1 \times V_{CCO}$ To: $0.1 \times V_{CCI}$ in *Electrical Characteristics—2.5-V Supply*..... 12
- Changed CMTI MIN value From: 35 To: 40 in *Electrical Characteristics—3.3-V Supply* 12
- Changed PWD MAX value From: 4.7 To: 4.9 in *Switching Characteristics—5-V Supply*..... 13
- Changed $t_{sk(o)}$ MAX value From: 3.5 To: 4 in *Switching Characteristics—5-V Supply*..... 13
- Changed t_{DO} MAX value From: 9 To: 0.3 in *Switching Characteristics—5-V Supply*..... 13
- Changed t_{DO} MAX value From: 9 To: 0.3 in *Switching Characteristics—3.3-V Supply*..... 14
- Changed t_{DO} MAX value From: 9 To: 0.3 in *Switching Characteristics—2.5-V Supply*..... 14
- Added Note B to [Figure 15](#)..... 19

5 说明（续）

ISO7730 器件具有三条全部同向的通道，而 ISO7731 器件具有两条正向通道和一条反向通道。如果输入功率或信号出现损失，不带后缀 F 的器件默认输出高电平，带后缀 F 的器件默认输出低电平。有关更多详细信息，请参阅 [Device Functional Modes](#) 器件功能模式 部分。

该系列器件与隔离式电源结合使用，有助于防止数据总线（例如，RS-485、RS-232 和 CAN）或者其他电路上的噪声电流进入本地接地以及干扰或损坏敏感电路。凭借创新型芯片设计和布局技术，ISO773x 器件的电磁兼容性得到了显著增强，可轻松满足系统级 ESD、EFT、浪涌和辐射方面的合规性。ISO773x 系列器件采用 16 引脚宽体 SOIC 和 QSOP 封装。

6 Pin Configuration and Functions

ISO7730 DW and DBQ Packages
16-Pin SOIC-WB and QSOP
Top View

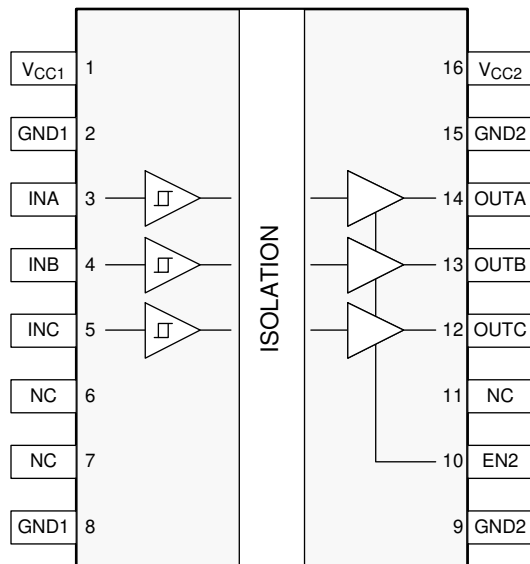

ISO7731 DW and DBQ Packages
16-Pin SOIC-WB and QSOP
Top View

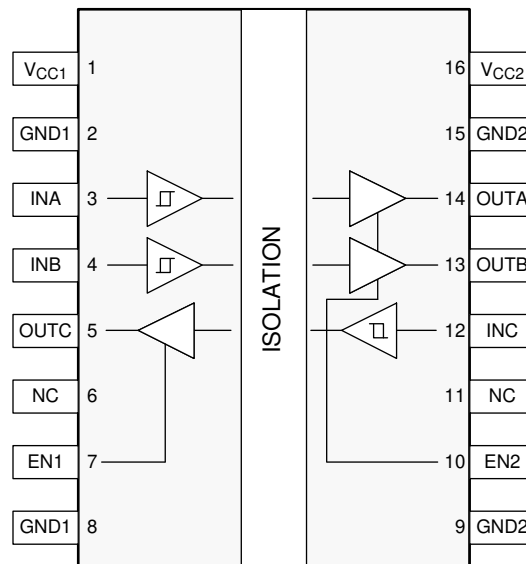

Pin Functions

NAME	PIN NO.		I/O	DESCRIPTION
	ISO7730	ISO7731		
EN1	—	7	I	Output enable 1. Output pins on side 1 are enabled when EN1 is high or open and in high-impedance state when EN1 is low.
EN2	10	10	I	Output enable 2. Output pins on side 2 are enabled when EN2 is high or open and in high-impedance state when EN2 is low.
GND1	2, 8	2, 8	—	Ground connection for V_{CC1}
GND2	9, 15	9, 15	—	Ground connection for V_{CC2}
INA	3	3	I	Input, channel A
INB	4	4	I	Input, channel B
INC	5	12	I	Input, channel C
NC	6, 7, 11	6, 11	—	Not connected
OUTA	14	14	O	Output, channel A
OUTB	13	13	O	Output, channel B
OUTC	12	5	O	Output, channel C
V_{CC1}	1	1	—	Power supply, V_{CC1}
V_{CC2}	16	16	—	Power supply, V_{CC2}

7 Specifications

7.1 Absolute Maximum Ratings

See ⁽¹⁾

		MIN	MAX	UNIT
V_{CC1}, V_{CC2}	Supply voltage ⁽²⁾	-0.5	6	V
V	Voltage at INx, OUTx, ENx	-0.5	$V_{CCX} + 0.5^{(3)}$	V
I_O	Output current	-15	15	mA
T_J	Junction temperature		150	°C
T_{stg}	Storage temperature	-65	150	°C

- (1) Stresses beyond those listed under *Absolute Maximum Ratings* may cause permanent damage to the device. These are stress ratings only and functional operation of the device at these or any other conditions beyond those indicated under *Recommended Operating Conditions* is not implied. Exposure to absolute-maximum-rated conditions for extended periods may affect device reliability.
- (2) All voltage values except differential I/O bus voltages are with respect to the local ground terminal (GND1 or GND2) and are peak voltage values.
- (3) Maximum voltage must not exceed 6 V.

7.2 ESD Ratings

		VALUE	UNIT
$V_{(ESD)}$	Electrostatic discharge	Human body model (HBM), per ANSI/ESDA/JEDEC JS-001, all pins ⁽¹⁾	±6000
		Charged device model (CDM), per JEDEC specification JESD22-C101, all pins ⁽²⁾	±1500
		Contact discharge per IEC 61000-4-2; Isolation barrier withstand test ⁽³⁾⁽⁴⁾	±8000

- (1) JEDEC document JEP155 states that 500-V HBM allows safe manufacturing with a standard ESD control process.
- (2) JEDEC document JEP157 states that 250-V CDM allows safe manufacturing with a standard ESD control process.
- (3) IEC ESD strike is applied across the barrier with all pins on each side tied together creating a two-terminal device.
- (4) Testing is carried out in air or oil to determine the intrinsic contact discharge capability of the device.

7.3 Recommended Operating Conditions

		MIN	NOM	MAX	UNIT
V_{CC1}, V_{CC2}	Supply voltage	2.25		5.5	V
$V_{CC(UVLO+)}$	UVLO threshold when supply voltage is rising		2	2.25	V
$V_{CC(UVLO-)}$	UVLO threshold when supply voltage is falling	1.7	1.8		V
$V_{HYS(UVLO)}$	Supply voltage UVLO hysteresis	100	200		mV
I_{OH}	High-level output current	$V_{CCO}^{(1)} = 5\text{ V}$		-4	mA
		$V_{CCO} = 3.3\text{ V}$		-2	
		$V_{CCO} = 2.5\text{ V}$		-1	
I_{OL}	Low-level output current	$V_{CCO} = 5\text{ V}$		4	mA
		$V_{CCO} = 3.3\text{ V}$		2	
		$V_{CCO} = 2.5\text{ V}$		1	
V_{IH}	High-level input voltage	$0.7 \times V_{CCI}^{(1)}$		V_{CCI}	V
V_{IL}	Low-level input voltage	0		$0.3 \times V_{CCI}$	V
$DR^{(2)}$	Data rate	0		100	Mbps
T_A	Ambient temperature	-55	25	125	°C

- (1) V_{CCI} = Input-side V_{CC} ; V_{CCO} = Output-side V_{CC} .
- (2) 100 Mbps is the maximum specified data rate, although higher data rates are possible.

7.4 Thermal Information

THERMAL METRIC ⁽¹⁾		ISO773x		UNIT
		DW (SOIC)	DBQ (QSOP)	
		16 Pins	16 Pins	
$R_{\theta JA}$	Junction-to-ambient thermal resistance	81.4	109	°C/W
$R_{\theta JC(top)}$	Junction-to-case(top) thermal resistance	44.9	46.8	°C/W
$R_{\theta JB}$	Junction-to-board thermal resistance	45.9	60.6	°C/W
Ψ_{JT}	Junction-to-top characterization parameter	28.1	35.9	°C/W
Ψ_{JB}	Junction-to-board characterization parameter	45.5	60	°C/W
$R_{\theta JC(bottom)}$	Junction-to-case(bottom) thermal resistance	—	—	°C/W

(1) For more information about traditional and new thermal metrics, see the [Semiconductor and IC Package Thermal Metrics application report](#).

7.5 Power Ratings

PARAMETER		TEST CONDITIONS	MIN	TYP	MAX	UNIT
ISO7730						
P_D	Maximum power dissipation	$V_{CC1} = V_{CC2} = 5.5\text{ V}$, $T_J = 150^\circ\text{C}$, $C_L = 15\text{ pF}$, input a 50-MHz 50% duty cycle square wave			150	mW
P_{D1}	Maximum power dissipation by side-1				25	mW
P_{D2}	Maximum power dissipation by side-2				125	mW
ISO7731						
P_D	Maximum power dissipation	$V_{CC1} = V_{CC2} = 5.5\text{ V}$, $T_J = 150^\circ\text{C}$, $C_L = 15\text{ pF}$, input a 50-MHz 50% duty cycle square wave			150	mW
P_{D1}	Maximum power dissipation by side-1				50	mW
P_{D2}	Maximum power dissipation by side-2				100	mW

7.6 Insulation Specifications

PARAMETER		TEST CONDITIONS	SPECIFICATION		UNIT
			DW-16	DBQ-16	
CLR	External clearance ⁽¹⁾	Shortest terminal-to-terminal distance through air	>8	>3.7	mm
CPG	External creepage ⁽¹⁾	Shortest terminal-to-terminal distance across the package surface	>8	>3.7	mm
DTI	Distance through the insulation	Minimum internal gap (internal clearance)	>21	>21	μm
CTI	Comparative tracking index	DIN EN 60112 (VDE 0303-11); IEC 60112; UL 746A	>600	>600	V
	Material group	According to IEC 60664-1	I	I	
	Overvoltage category per IEC 60664-1	Rated mains voltage ≤ 150 V _{RMS}	I–IV	I–IV	
		Rated mains voltage ≤ 300 V _{RMS}	I–IV	I–III	
		Rated mains voltage ≤ 600 V _{RMS}	I–IV	n/a	
		Rated mains voltage ≤ 1000 V _{RMS}	I–III	n/a	
'DIN V VDE V 0884-11:2017-01' ⁽²⁾					
V _{IORM}	Maximum repetitive peak isolation voltage	AC voltage (bipolar)	2121	566	V _{PK}
V _{IOWM}	Maximum working isolation voltage	AC voltage; Time dependent dielectric breakdown (TDDb) Test; See Figure 27	1500	400	V _{RMS}
		DC Voltage	2121	566	V _{DC}
V _{IOTM}	Maximum transient isolation voltage	V _{TEST} = V _{IOTM} , t = 60 s (qualification); V _{TEST} = 1.2 × V _{IOTM} , t = 1 s (100% production)	8000	4242	V _{PK}
V _{IOSM}	Maximum surge isolation voltage ⁽³⁾	Test method per IEC 62368-1, 1.2/50 μs waveform, V _{TEST} = 1.6 × V _{IOSM} (qualification)	8000	4000	V _{PK}
q _{pd}	Apparent charge ⁽⁴⁾	Method a, After Input/Output safety test subgroup 2/3, V _{ini} = V _{IOTM} , t _{ini} = 60 s; V _{pd(m)} = 1.2 × V _{IORM} , t _m = 10 s	≤5	≤5	pC
		Method a, After environmental tests subgroup 1, V _{ini} = V _{IOTM} , t _{ini} = 60 s; V _{pd(m)} = 1.6 × V _{IORM} , t _m = 10 s	≤5	≤5	
		Method b1; At routine test (100% production) and preconditioning (type test) V _{ini} = 1.2 × V _{IOTM} , t _{ini} = 1 s; V _{pd(m)} = 1.875 × V _{IORM} , t _m = 1 s	≤5	≤5	
C _{IO}	Barrier capacitance, input to output ⁽⁵⁾	V _{IO} = 0.4 × sin(2πft), f = 1 MHz	~0.7	~0.7	pF
R _{IO}	Isolation resistance ⁽⁵⁾	V _{IO} = 500 V, T _A = 25°C	>10 ¹²	>10 ¹²	Ω
		V _{IO} = 500 V, 100°C ≤ T _A ≤ 125°C	>10 ¹¹	>10 ¹¹	
		V _{IO} = 500 V at T _S = 150°C	>10 ⁹	>10 ⁹	
	Pollution degree		2	2	
	Climatic category		55/125/21	55/125/21	
UL 1577					
V _{ISO}	Withstanding isolation voltage	V _{TEST} = V _{ISO} , t = 60 s (qualification), V _{TEST} = 1.2 × V _{ISO} , t = 1 s (100% production)	5000	3000	V _{RMS}

- (1) Creepage and clearance requirements should be applied according to the specific equipment isolation standards of an application. Care should be taken to maintain the creepage and clearance distance of a board design to ensure that the mounting pads of the isolator on the printed-circuit board do not reduce this distance. Creepage and clearance on a printed-circuit board become equal in certain cases. Techniques such as inserting grooves and/or ribs on a printed circuit board are used to help increase these specifications.
- (2) This coupler is suitable for *safe electrical insulation* only within the safety ratings. Compliance with the safety ratings shall be ensured by means of suitable protective circuits.
- (3) Testing is carried out in air or oil to determine the intrinsic surge immunity of the isolation barrier.
- (4) Apparent charge is electrical discharge caused by a partial discharge (pd).
- (5) All pins on each side of the barrier tied together creating a two-terminal device.

7.7 Safety-Related Certifications

VDE	CSA	UL	CQC	TUV
Certified according to 'DIN V VDE V 0884-11:2017-01	Certified according to IEC 60950-1, IEC 62368-1 and IEC 60601-1	Certified according to UL 1577 Component Recognition Program	Certified according to GB 4943.1-2011	Certified according to EN 61010-1:2010 (3rd Ed) and EN 60950-1:2006/A2:2013
Maximum transient isolation voltage, 8000 V _{PK} (DW-16) and 4242 V _{PK} (DBQ-16); Maximum repetitive peak isolation voltage, 2121 V _{PK} (DW-16, Reinforced) and 566 V _{PK} (DBQ-16); Maximum surge isolation voltage, 8000 V _{PK} (DW-16) and 4000 V _{PK} (DBQ-16)	Reinforced insulation per CSA 60950-1-07+A1+A2 and IEC 60950-1 2nd Ed., 800 V _{RMS} (DW-16) and 370 V _{RMS} (DBQ-16) max working voltage (pollution degree 2, material group I); 2 MOPP (Means of Patient Protection) per CSA 60601-1:14 and IEC 60601-1 Ed. 3.1, 250 V _{RMS} (DW-16) max working voltage	DW-16: Single protection, 5000 V _{RMS} ; DBQ-16: Single protection, 3000 V _{RMS}	DW-16: Reinforced Insulation, Altitude ≤ 5000 m, Tropical Climate, 700 V _{RMS} maximum working voltage; DBQ-16: Basic Insulation, Altitude ≤ 5000 m, Tropical Climate, 400 V _{RMS} maximum working voltage	5000 V _{RMS} (DW-16) and 3000 V _{RMS} (DBQ-16) Reinforced insulation per EN 61010-1:2010 (3rd Ed) up to working voltage of 600 V _{RMS} (DW-16) and 300 V _{RMS} (DBQ-16) 5000 V _{RMS} (DW-16) and 3000 V _{RMS} (DBQ-16) Reinforced insulation per EN 60950-1:2006/A2:2013 up to working voltage of 800 V _{RMS} (DW-16) and 370 V _{RMS} (DBQ-16)
Certificate number: 40040142	Master contract number: 220991	File number: E181974	Certificate numbers: CQC15001121716 (DW-16) CQC18001199097 (DBQ-16)	Client ID number: 77311

7.8 Safety Limiting Values

Safety limiting⁽¹⁾ intends to minimize potential damage to the isolation barrier upon failure of input or output circuitry. A failure of the I/O can allow low resistance to ground or the supply and, without current limiting, dissipate sufficient power to overheat the die and damage the isolation barrier potentially leading to secondary system failures.

PARAMETER		TEST CONDITIONS	MIN	TYP	MAX	UNIT
DW-16 PACKAGE						
I _S	Safety input, output, or supply current	R _{θJA} = 81.4 °C/W, V _I = 5.5 V, T _J = 150°C, T _A = 25°C, see Figure 1			279	mA
		R _{θJA} = 81.4 °C/W, V _I = 3.6 V, T _J = 150°C, T _A = 25°C, see Figure 1			427	
		R _{θJA} = 81.4 °C/W, V _I = 2.75 V, T _J = 150°C, T _A = 25°C, see Figure 1			558	
P _S	Safety input, output, or total power	R _{θJA} = 81.4 °C/W, T _J = 150°C, T _A = 25°C, see Figure 3			1536	mW
T _S	Maximum safety temperature				150	°C
DBQ-16 PACKAGE						
I _S	Safety input, output, or supply current	R _{θJA} = 109.0°C/W, V _I = 5.5 V, T _J = 150°C, T _A = 25°C, see Figure 2			209	mA
		R _{θJA} = 109.0 °C/W, V _I = 3.6 V, T _J = 150°C, T _A = 25°C, see Figure 2			319	
		R _{θJA} = 109.0°C/W, V _I = 2.75 V, T _J = 150°C, T _A = 25°C, see Figure 2			417	
P _S	Safety input, output, or total power	R _{θJA} = 109.0°C/W, T _J = 150°C, T _A = 25°C, see Figure 4			1147	mW
T _S	Maximum safety temperature				150	°C

- (1) The maximum safety temperature is the maximum junction temperature specified for the device. The power dissipation and junction-to-air thermal impedance of the device installed in the application hardware determines the junction temperature. The assumed junction-to-air thermal resistance in the [Thermal Information](#) is that of a device installed on a High-K test board for leaded surface mount packages. The power is the recommended maximum input voltage times the current. The junction temperature is then the ambient temperature plus the power times the junction-to-air thermal resistance.

7.9 Electrical Characteristics—5-V Supply

 $V_{CC1} = V_{CC2} = 5\text{ V} \pm 10\%$ (over recommended operating conditions unless otherwise noted)

PARAMETER	TEST CONDITIONS	MIN	TYP	MAX	UNIT
V_{OH}	High-level output voltage $I_{OH} = -4\text{ mA}$; see Figure 13	$V_{CCO}^{(1)} - 0.4$	4.8		V
V_{OL}	Low-level output voltage $I_{OL} = 4\text{ mA}$; see Figure 13		0.2	0.4	V
$V_{IT+(IN)}$	Rising input voltage threshold		$0.6 \times V_{CC1}$	$0.7 \times V_{CC1}$	V
$V_{IT-(IN)}$	Falling input voltage threshold	$0.3 \times V_{CC1}$	$0.4 \times V_{CC1}$		V
$V_{I(HYS)}$	Input threshold voltage hysteresis	$0.1 \times V_{CC1}$	$0.2 \times V_{CC1}$		V
I_{IH}	High-level input current $V_{IH} = V_{CC1}^{(1)}$ at INx or ENx			10	μA
I_{IL}	Low-level input current $V_{IL} = 0\text{ V}$ at INx or ENx	-10			μA
CMTI	Common-mode transient immunity $V_I = V_{CC1}$ or 0 V , $V_{CM} = 1200\text{ V}$; see Figure 16	85	100		$\text{kV}/\mu\text{s}$
C_I	Input Capacitance ⁽²⁾ $V_I = V_{CC}/2 + 0.4x\sin(2\pi ft)$, $f = 1\text{ MHz}$, $V_{CC} = 5\text{ V}$		2		pF

 (1) V_{CC1} = Input-side V_{CC} ; V_{CCO} = Output-side V_{CC} .

(2) Measured from input pin to ground.

7.10 Supply Current Characteristics—5-V Supply

 $V_{CC1} = V_{CC2} = 5\text{ V} \pm 10\%$ (over recommended operating conditions unless otherwise noted)

PARAMETER	TEST CONDITIONS	SUPPLY CURRENT	MIN	TYP	MAX	UNIT	
ISO7730							
Supply current - disable	$EN2 = 0\text{ V}$; $V_I = V_{CC1}$ (ISO7730); $V_I = 0\text{ V}$ (ISO7730 with F suffix)	I_{CC1}		1	1.4	mA	
		I_{CC2}		0.3	0.4	mA	
	$EN2 = 0\text{ V}$; $V_I = 0\text{ V}$ (ISO7730); $V_I = V_{CC1}$ (ISO7730 with F suffix)	I_{CC1}		4.3	6	mA	
		I_{CC2}		0.3	0.4	mA	
Supply current - DC signal	$EN2 = V_{CC2}$; $V_I = V_{CC1}$ (ISO7730); $V_I = 0\text{ V}$ (ISO7730 with F suffix)	I_{CC1}		1	1.4	mA	
		I_{CC2}		1.6	2.5	mA	
	$EN2 = V_{CC2}$; $V_I = 0\text{ V}$ (ISO7730); $V_I = V_{CC1}$ (ISO7730 with F suffix)	I_{CC1}		4.3	6	mA	
		I_{CC2}		1.8	2.7	mA	
Supply current - AC signal	$EN2 = V_{CC1}$; All channels switching with square wave clock input; $C_L = 15\text{ pF}$	1 Mbps	I_{CC1}		2.6	3.7	mA
			I_{CC2}		1.9	2.8	mA
		10 Mbps	I_{CC1}		2.7	3.8	mA
			I_{CC2}		3.3	4.5	mA
		100 Mbps	I_{CC1}		3.6	4.6	mA
			I_{CC2}		17.5	21	mA
ISO7731							
Supply current - disable	$EN1 = EN2 = 0\text{ V}$; $V_I = V_{CC1}^{(1)}$ (ISO7731); $V_I = 0\text{ V}$ (ISO7731 with F suffix)	I_{CC1}		0.8	1.2	mA	
		I_{CC2}		0.7	1	mA	
	$EN1 = EN2 = 0\text{ V}$; $V_I = 0\text{ V}$ (ISO7731); $V_I = V_{CC1}$ (ISO7731 with F suffix)	I_{CC1}		3	4.3	mA	
		I_{CC2}		1.8	2.6	mA	
Supply current - DC signal	$EN1 = EN2 = V_{CC1}$; $V_I = V_{CC1}$ (ISO7731); $V_I = 0\text{ V}$ (ISO7731 with F suffix)	I_{CC1}		1.3	1.7	mA	
		I_{CC2}		1.6	2.2	mA	
	$EN1 = EN2 = V_{CC1}$; $V_I = 0\text{ V}$ (ISO7731); $V_I = V_{CC1}$ (ISO7731 with F suffix)	I_{CC1}		3.5	5	mA	
		I_{CC2}		2.8	4.1	mA	
Supply current - AC signal	$EN1 = EN2 = V_{CC1}$; All channels switching with square wave clock input; $C_L = 15\text{ pF}$	1 Mbps	I_{CC1}		2.7	3.4	mA
			I_{CC2}		2.3	3.3	mA
		10 Mbps	I_{CC1}		3	4	mA
			I_{CC2}		3.3	4.4	mA
		100 Mbps	I_{CC1}		8.5	11	mA
			I_{CC2}		13.1	16	mA

 (1) V_{CC1} = Input-side V_{CC}

7.11 Electrical Characteristics—3.3-V Supply

 $V_{CC1} = V_{CC2} = 3.3\text{ V} \pm 10\%$ (over recommended operating conditions unless otherwise noted)

PARAMETER	TEST CONDITIONS	MIN	TYP	MAX	UNIT
V_{OH}	High-level output voltage $I_{OH} = -2\text{ mA}$; see Figure 13	$V_{CCO}^{(1)} - 0.3$	3.2		V
V_{OL}	Low-level output voltage $I_{OL} = 2\text{ mA}$; see Figure 13		0.1	0.3	V
$V_{IT+(IN)}$	Rising input voltage threshold		$0.6 \times V_{CC1}$	$0.7 \times V_{CC1}$	V
$V_{IT-(IN)}$	Falling input voltage threshold	$0.3 \times V_{CC1}$	$0.4 \times V_{CC1}$		V
$V_{I(HYS)}$	Input threshold voltage hysteresis	$0.1 \times V_{CC1}$	$0.2 \times V_{CC1}$		V
I_{IH}	High-level input current $V_{IH} = V_{CC1}^{(1)}$ at INx or ENx			10	μA
I_{IL}	Low-level input current $V_{IL} = 0\text{ V}$ at INx or ENx	-10			μA
CMTI	Common-mode transient immunity $V_I = V_{CC1}$ or 0 V , $V_{CM} = 1200\text{ V}$; see Figure 16	85	100		$\text{kV}/\mu\text{s}$

(1) V_{CC1} = Input-side V_{CC} ; V_{CCO} = Output-side V_{CC} .

7.12 Supply Current Characteristics—3.3-V Supply

 $V_{CC1} = V_{CC2} = 3.3\text{ V} \pm 10\%$ (over recommended operating conditions unless otherwise noted)

PARAMETER	TEST CONDITIONS	SUPPLY CURRENT	MIN	TYP	MAX	UNIT	
ISO7730							
Supply current - disable	$EN2 = 0\text{ V}$; $V_I = V_{CC1}$ (ISO7730); $V_I = 0\text{ V}$ (ISO7730 with F suffix)	I_{CC1}		1	1.4	mA	
		I_{CC2}		0.3	0.4	mA	
	$EN2 = 0\text{ V}$; $V_I = 0\text{ V}$ (ISO7730); $V_I = V_{CC1}$ (ISO7730 with F suffix)	I_{CC1}		4.3	6	mA	
		I_{CC2}		0.3	0.4	mA	
Supply current - DC signal	$EN2 = V_{CC2}$; $V_I = V_{CC1}$ (ISO7730); $V_I = 0\text{ V}$ (ISO7730 with F suffix)	I_{CC1}		1	1.4	mA	
		I_{CC2}		1.6	2.5	mA	
	$EN2 = V_{CC2}$; $V_I = 0\text{ V}$ (ISO7730); $V_I = V_{CC1}$ (ISO7730 with F suffix)	I_{CC1}		4.3	6	mA	
		I_{CC2}		1.8	2.7	mA	
Supply current - AC signal	$EN2 = V_{CC1}$; All channels switching with square wave clock input; $C_L = 15\text{ pF}$	1 Mbps	I_{CC1}		2.6	3.7	mA
			I_{CC2}		1.8	2.8	mA
		10 Mbps	I_{CC1}		2.7	3.8	mA
			I_{CC2}		2.8	3.9	mA
		100 Mbps	I_{CC1}		3.3	4.3	mA
			I_{CC2}		13	17	mA
ISO7731							
Supply current - disable	$EN1 = EN2 = 0\text{ V}$; $V_I = V_{CC1}^{(1)}$ (ISO7731); $V_I = 0\text{ V}$ (ISO7731 with F suffix)	I_{CC1}		0.8	1.2	mA	
		I_{CC2}		0.7	1	mA	
	$EN1 = EN2 = 0\text{ V}$; $V_I = 0\text{ V}$ (ISO7731); $V_I = V_{CC1}$ (ISO7731 with F suffix)	I_{CC1}		3	4.3	mA	
		I_{CC2}		1.8	2.6	mA	
Supply current - DC signal	$EN1 = EN2 = V_{CC1}$; $V_I = V_{CC1}$ (ISO7731); $V_I = 0\text{ V}$ (ISO7731 with F suffix)	I_{CC1}		1.3	1.7	mA	
		I_{CC2}		1.6	2.2	mA	
	$EN1 = EN2 = V_{CC1}$; $V_I = 0\text{ V}$ (ISO7731); $V_I = V_{CC1}$ (ISO7731 with F suffix)	I_{CC1}		3.5	5	mA	
		I_{CC2}		2.8	4.1	mA	
Supply current - AC signal	$EN1 = EN2 = V_{CC1}$; All channels switching with square wave clock input; $C_L = 15\text{ pF}$	1 Mbps	I_{CC1}		2.4	3.4	mA
			I_{CC2}		2.2	3.3	mA
		10 Mbps	I_{CC1}		2.8	3.8	mA
			I_{CC2}		2.9	4	mA
		100 Mbps	I_{CC1}		6.7	8.5	mA
			I_{CC2}		10	12.5	mA

(1) V_{CC1} = Input-side V_{CC}

7.13 Electrical Characteristics—2.5-V Supply

 $V_{CC1} = V_{CC2} = 2.5\text{ V} \pm 10\%$ (over recommended operating conditions unless otherwise noted)

PARAMETER	TEST CONDITIONS	MIN	TYP	MAX	UNIT
V_{OH}	High-level output voltage $I_{OH} = -1\text{ mA}$; see Figure 13	$V_{CCO}^{(1)} - 0.2$	2.45		V
V_{OL}	Low-level output voltage $I_{OL} = 1\text{ mA}$; see Figure 13		0.05	0.2	V
$V_{IT+(IN)}$	Rising input voltage threshold		$0.6 \times V_{CCI}$	$0.7 \times V_{CCI}$	V
$V_{IT-(IN)}$	Falling input voltage threshold	$0.3 \times V_{CCI}$	$0.4 \times V_{CCI}$		V
$V_{I(HYS)}$	Input threshold voltage hysteresis	$0.1 \times V_{CCI}$	$0.2 \times V_{CCI}$		V
I_{IH}	High-level input current $V_{IH} = V_{CC1}^{(1)}$ at INx or ENx			10	μA
I_{IL}	Low-level input current $V_{IL} = 0\text{ V}$ at INx or ENx	-10			μA
CMTI	Common-mode transient immunity $V_I = V_{CCI}$ or 0 V , $V_{CM} = 1200\text{ V}$; see Figure 16	85	100		kV/ μs

 (1) V_{CCI} = Input-side V_{CC} ; V_{CCO} = Output-side V_{CC} .

7.14 Supply Current Characteristics—2.5-V Supply

 $V_{CC1} = V_{CC2} = 2.5\text{ V} \pm 10\%$ (over recommended operating conditions unless otherwise noted)

PARAMETER	TEST CONDITIONS	SUPPLY CURRENT	MIN	TYP	MAX	UNIT	
ISO7730							
Supply current - disable	$EN2 = 0\text{ V}$; $V_I = V_{CC1}$ (ISO7730); $V_I = 0\text{ V}$ (ISO7730 with F suffix)	I_{CC1}		1	1.4	mA	
		I_{CC2}		0.3	0.4	mA	
	$EN2 = 0\text{ V}$; $V_I = 0\text{ V}$ (ISO7730); $V_I = V_{CC1}$ (ISO7730 with F suffix)	I_{CC1}		4.3	6	mA	
		I_{CC2}		0.3	0.4	mA	
Supply current - DC signal	$EN2 = V_{CC2}$; $V_I = V_{CC1}$ (ISO7730); $V_I = 0\text{ V}$ (ISO7730 with F suffix)	I_{CC1}		1	1.4	mA	
		I_{CC2}		1.6	2.5	mA	
	$EN2 = V_{CC2}$; $V_I = 0\text{ V}$ (ISO7730); $V_I = V_{CC1}$ (ISO7730 with F suffix)	I_{CC1}		4.3	6	mA	
		I_{CC2}		1.8	2.7	mA	
Supply current - AC signal	$EN2 = V_{CC2}$; All channels switching with square wave clock input; $C_L = 15\text{ pF}$	1 Mbps	I_{CC1}		2.6	3.7	mA
			I_{CC2}		1.8	2.7	mA
		10 Mbps	I_{CC1}		2.6	3.8	mA
			I_{CC2}		2.5	3.6	mA
		100 Mbps	I_{CC1}		3.1	4.2	mA
			I_{CC2}		10.2	14	mA
ISO7731							
Supply current - disable	$EN1 = EN2 = 0\text{ V}$; $V_I = V_{CC1}^{(1)}$ (ISO7731); $V_I = 0\text{ V}$ (ISO7731 with F suffix)	I_{CC1}		0.8	1.2	mA	
		I_{CC2}		0.7	1	mA	
	$EN1 = EN2 = 0\text{ V}$; $V_I = 0\text{ V}$ (ISO7731); $V_I = V_{CC1}$ (ISO7731 with F suffix)	I_{CC1}		3	4.3	mA	
		I_{CC2}		1.8	2.6	mA	
Supply current - DC signal	$EN1 = EN2 = V_{CC1}$; $V_I = V_{CC1}$ (ISO7731); $V_I = 0\text{ V}$ (ISO7731 with F suffix)	I_{CC1}		1.3	1.7	mA	
		I_{CC2}		1.6	2.2	mA	
	$EN1 = EN2 = V_{CC1}$; $V_I = 0\text{ V}$ (ISO7731); $V_I = V_{CC1}$ (ISO7731 with F suffix)	I_{CC1}		3.5	5	mA	
		I_{CC2}		2.8	4.1	mA	
Supply current - AC signal	$EN1 = EN2 = V_{CC1}$; All channels switching with square wave clock input; $C_L = 15\text{ pF}$	1 Mbps	I_{CC1}		2.4	3.4	mA
			I_{CC2}		2.2	3.2	mA
		10 Mbps	I_{CC1}		2.7	3.7	mA
			I_{CC2}		2.7	3.8	mA
		100 Mbps	I_{CC1}		5.6	7	mA
			I_{CC2}		8	10	mA

 (1) V_{CCI} = Input-side V_{CC}

7.15 Switching Characteristics—5-V Supply

 $V_{CC1} = V_{CC2} = 5\text{ V} \pm 10\%$ (over recommended operating conditions unless otherwise noted)

PARAMETER		TEST CONDITIONS	MIN	TYP	MAX	UNIT
t_{PLH} , t_{PHL}	Propagation delay time	See Figure 13	6	11	16	ns
PWD	Pulse width distortion ⁽¹⁾ $ t_{PHL} - t_{PLH} $		0.6	4.9	ns	
$t_{sk(o)}$	Channel-to-channel output skew time ⁽²⁾	Same-direction channels			4	ns
$t_{sk(pp)}$	Part-to-part skew time ⁽³⁾				4.5	ns
t_r	Output signal rise time	See Figure 13		1.3	3.9	ns
t_f	Output signal fall time			1.4	3.9	ns
t_{PHZ}	Disable propagation delay, high-to-high impedance output	See Figure 14		8	20	ns
t_{PLZ}	Disable propagation delay, low-to-high impedance output			8	20	ns
t_{pZH}	Enable propagation delay, high impedance-to-high output for ISO773x			7	20	ns
	Enable propagation delay, high impedance-to-high output for ISO773x with F suffix			3	8.5	μs
t_{pZL}	Enable propagation delay, high impedance-to-low output for ISO773x			3	8.5	μs
	Enable propagation delay, high impedance-to-low output for ISO773x with F suffix			7	20	ns
t_{DO}	Default output delay time from input power loss	Measured from the time V_{CC} goes below 1.7 V. See Figure 15		0.1	0.3	μs
t_e	Time interval error	$2^{16} - 1$ PRBS data at 100 Mbps		0.6		ns

- (1) Also known as pulse skew.
- (2) $t_{sk(o)}$ is the skew between outputs of a single device with all driving inputs connected together and the outputs switching in the same direction while driving identical loads.
- (3) $t_{sk(pp)}$ is the magnitude of the difference in propagation delay times between any terminals of different devices switching in the same direction while operating at identical supply voltages, temperature, input signals and loads.

7.16 Switching Characteristics—3.3-V Supply

 $V_{CC1} = V_{CC2} = 3.3 \text{ V} \pm 10\%$ (over recommended operating conditions unless otherwise noted)

PARAMETER		TEST CONDITIONS	MIN	TYP	MAX	UNIT
t_{PLH} , t_{PHL}	Propagation delay time	See Figure 13	6	11	16	ns
PWD	Pulse width distortion ⁽¹⁾ $ t_{PHL} - t_{PLH} $					
$t_{sk(o)}$	Channel-to-channel output skew time ⁽²⁾	Same-direction channels			4.1	ns
$t_{sk(pp)}$	Part-to-part skew time ⁽³⁾				4.5	ns
t_r	Output signal rise time	See Figure 13		1.3	3	ns
t_f	Output signal fall time					
t_{PHZ}	Disable propagation delay, high-to-high impedance output	See Figure 14			17	30
t_{PLZ}	Disable propagation delay, low-to-high impedance output					
t_{PZH}	Enable propagation delay, high impedance-to-high output for ISO773x					
	Enable propagation delay, high impedance-to-high output for ISO773x with F suffix					
t_{PZL}	Enable propagation delay, high impedance-to-low output for ISO773x					
	Enable propagation delay, high impedance-to-low output for ISO773x with F suffix					
t_{DO}	Default output delay time from input power loss	Measured from the time V_{CC} goes below 1.7 V. See Figure 15		0.1	0.3	μ s
t_{ie}	Time interval error	$2^{16} - 1$ PRBS data at 100 Mbps		0.6		ns

- (1) Also known as Pulse Skew.
- (2) $t_{sk(o)}$ is the skew between outputs of a single device with all driving inputs connected together and the outputs switching in the same direction while driving identical loads.
- (3) $t_{sk(pp)}$ is the magnitude of the difference in propagation delay times between any terminals of different devices switching in the same direction while operating at identical supply voltages, temperature, input signals and loads.

7.17 Switching Characteristics—2.5-V Supply

 $V_{CC1} = V_{CC2} = 2.5 \text{ V} \pm 10\%$ (over recommended operating conditions unless otherwise noted)

PARAMETER		TEST CONDITIONS	MIN	TYP	MAX	UNIT
t_{PLH} , t_{PHL}	Propagation delay time	See Figure 13	7.5	12	18.5	ns
PWD	Pulse width distortion ⁽¹⁾ $ t_{PHL} - t_{PLH} $					
$t_{sk(o)}$	Channel-to-channel output skew time ⁽²⁾	Same-direction Channels			4.1	ns
$t_{sk(pp)}$	Part-to-part skew time ⁽³⁾				4.6	ns
t_r	Output signal rise time	See Figure 13		1	3.5	ns
t_f	Output signal fall time					
t_{PHZ}	Disable propagation delay, high-to-high impedance output	See Figure 14			22	40
t_{PLZ}	Disable propagation delay, low-to-high impedance output					
t_{PZH}	Enable propagation delay, high impedance-to-high output for ISO773x					
	Enable propagation delay, high impedance-to-high output for ISO773x with F suffix					
t_{PZL}	Enable propagation delay, high impedance-to-low output for ISO773x					
	Enable propagation delay, high impedance-to-low output for ISO773x with F suffix					
t_{DO}	Default output delay time from input power loss	Measured from the time V_{CC} goes below 1.7 V. See Figure 15		0.1	0.3	μ s
t_{ie}	Time interval error	$2^{16} - 1$ PRBS data at 100 Mbps		0.6		ns

- (1) Also known as pulse skew.
- (2) $t_{sk(o)}$ is the skew between outputs of a single device with all driving inputs connected together and the outputs switching in the same direction while driving identical loads.
- (3) $t_{sk(pp)}$ is the magnitude of the difference in propagation delay times between any terminals of different devices switching in the same direction while operating at identical supply voltages, temperature, input signals and loads.

7.18 Insulation Characteristics Curves

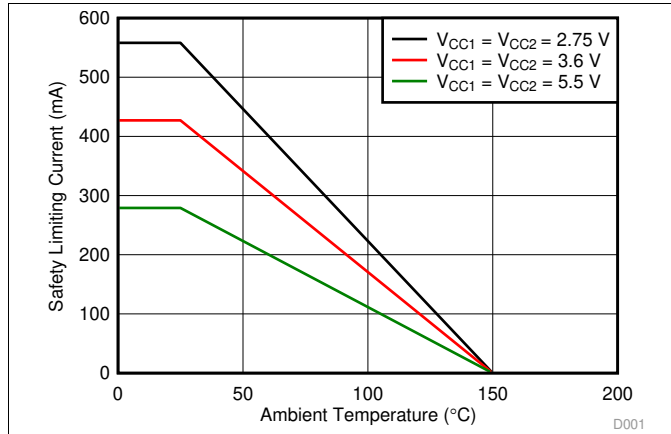

Figure 1. Thermal Derating Curve for Safety Limiting Current per VDE for DW-16 Package

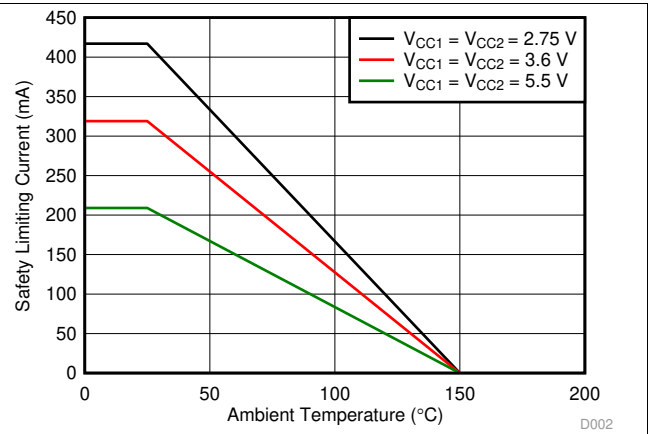

Figure 2. Thermal Derating Curve for Safety Limiting Current per VDE for DBQ-16 Package

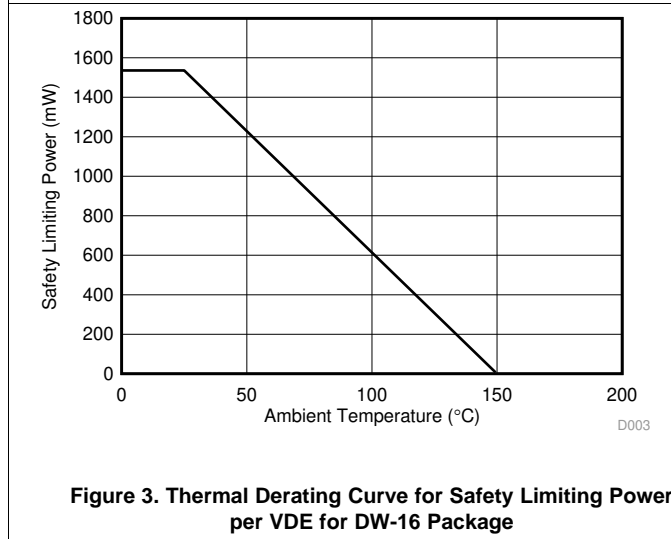

Figure 3. Thermal Derating Curve for Safety Limiting Power per VDE for DW-16 Package

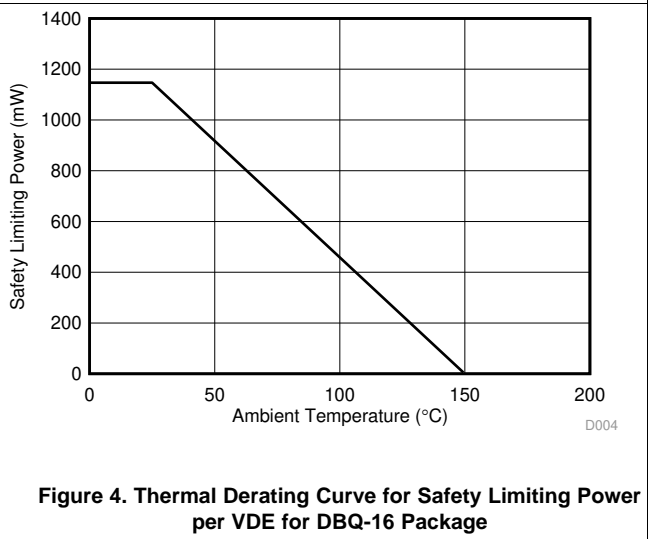
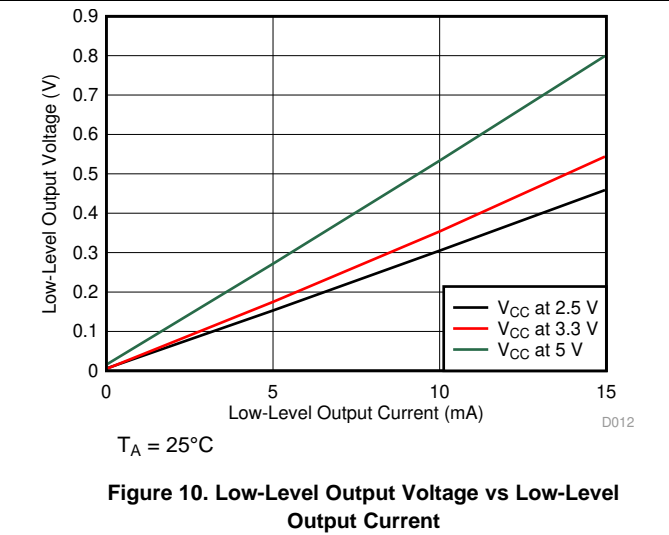
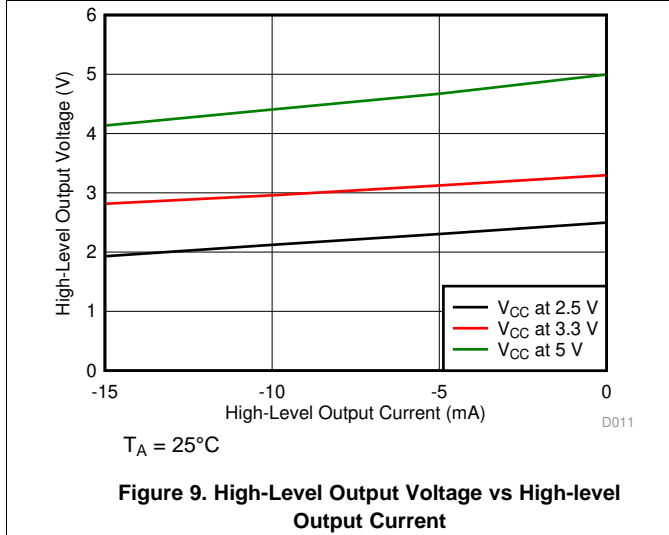
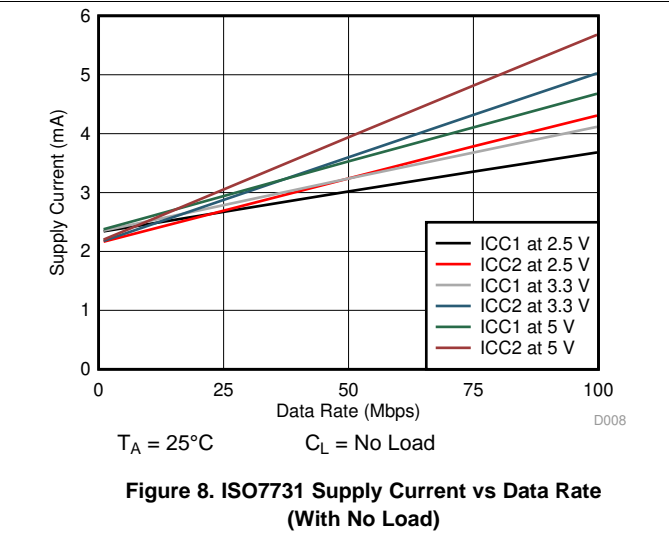
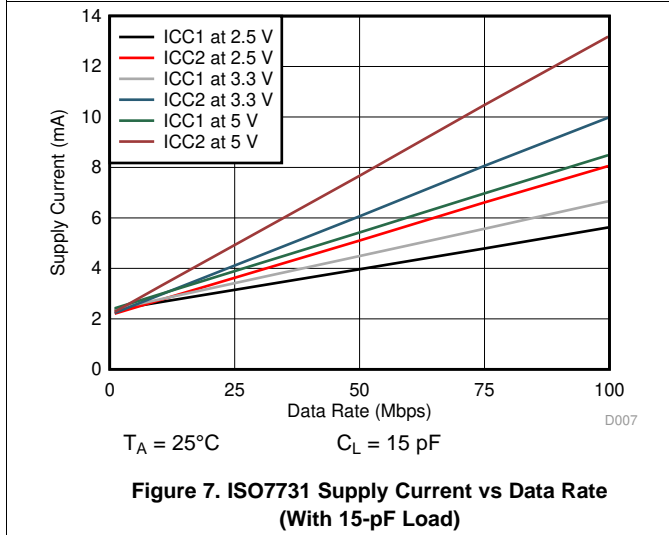
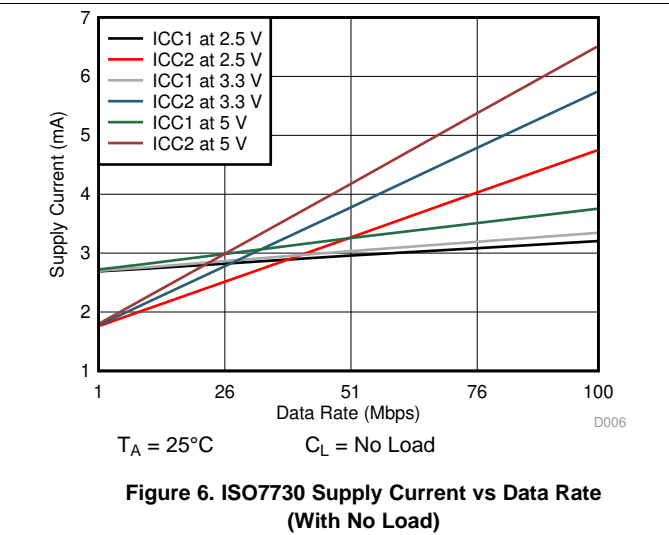
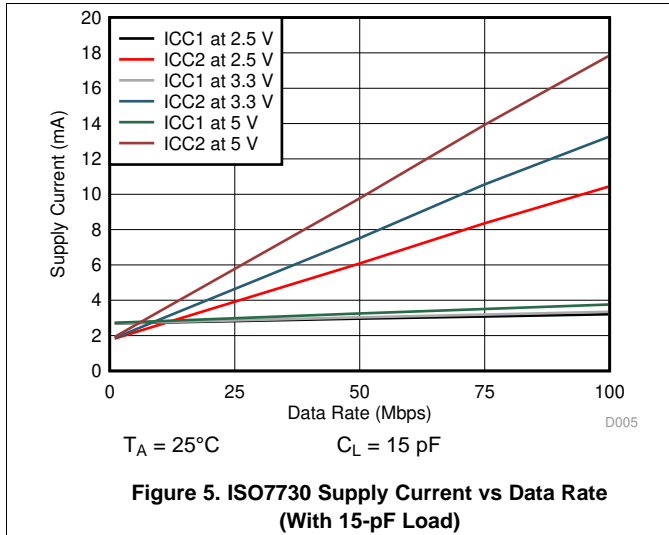
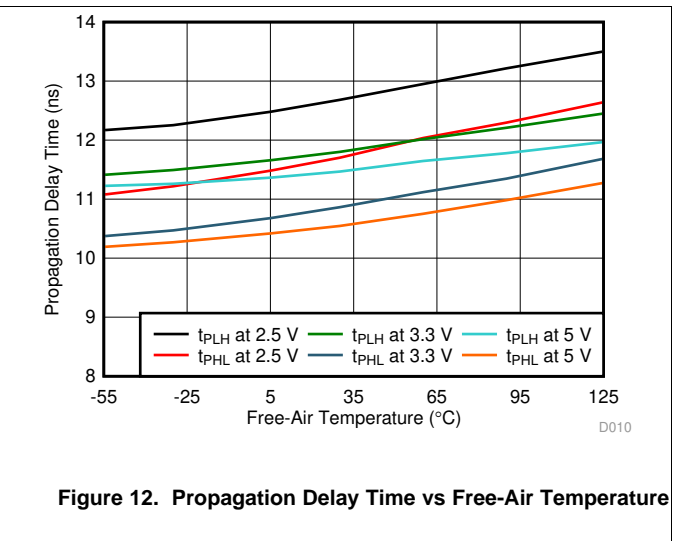
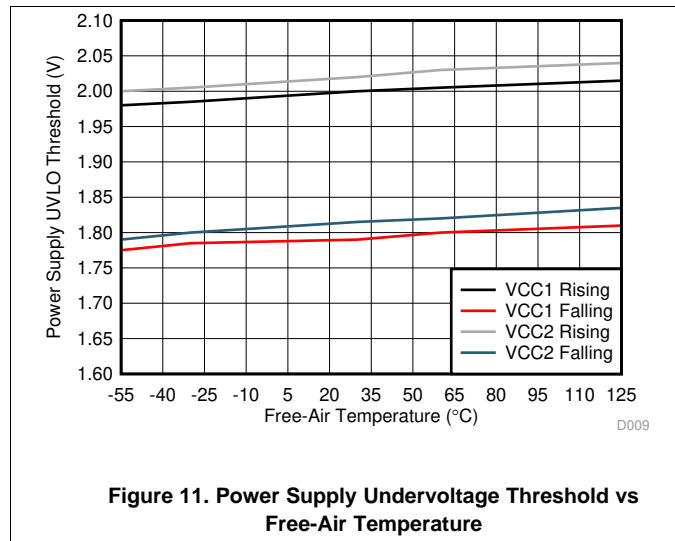

Figure 4. Thermal Derating Curve for Safety Limiting Power per VDE for DBQ-16 Package

7.19 Typical Characteristics



Typical Characteristics (continued)



8 Parameter Measurement Information

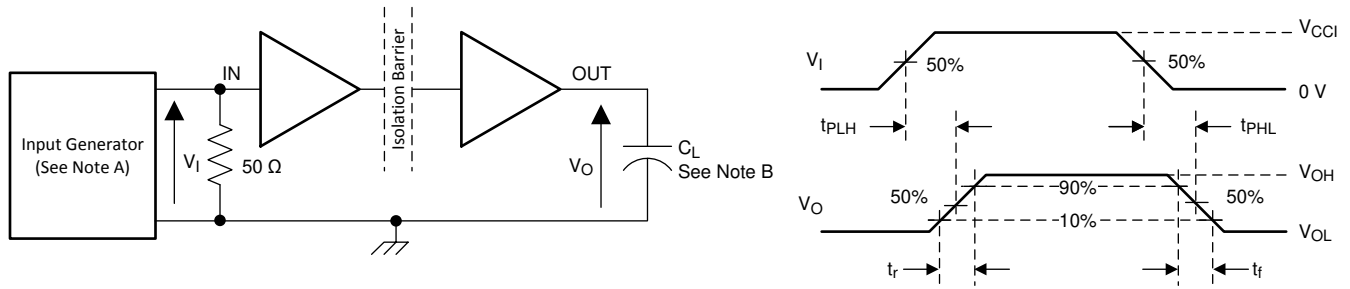

- A. The input pulse is supplied by a generator having the following characteristics: PRR \leq 50 kHz, 50% duty cycle, $t_r \leq 3$ ns, $t_f \leq 3$ ns, $Z_O = 50 \Omega$. At the input, 50Ω resistor is required to terminate Input Generator signal. It is not needed in actual application.
- B. $C_L = 15$ pF and includes instrumentation and fixture capacitance within $\pm 20\%$.

Figure 13. Switching Characteristics Test Circuit and Voltage Waveforms

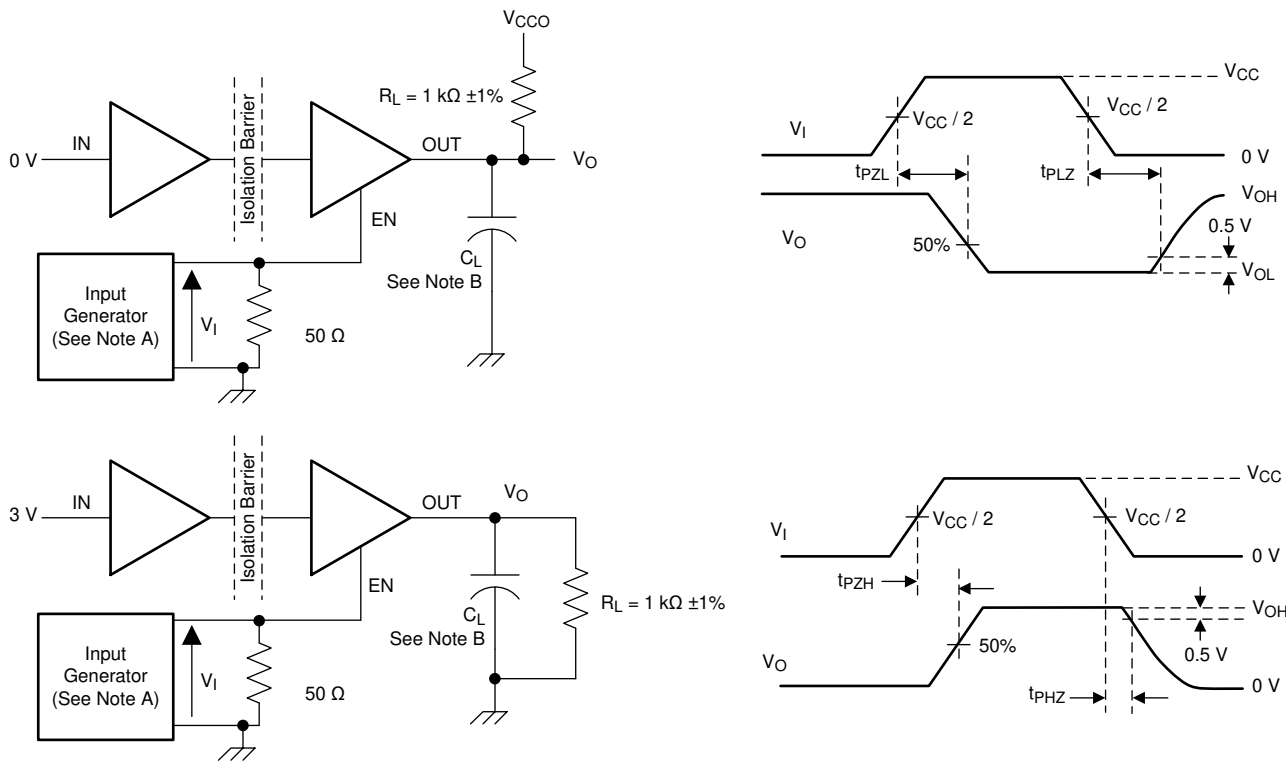

Copyright © 2016, Texas Instruments Incorporated

- A. The input pulse is supplied by a generator having the following characteristics: PRR \leq 10 kHz, 50% duty cycle, $t_r \leq 3$ ns, $t_f \leq 3$ ns, $Z_O = 50 \Omega$.
- B. $C_L = 15$ pF and includes instrumentation and fixture capacitance within $\pm 20\%$.

Figure 14. Enable/Disable Propagation Delay Time Test Circuit and Waveform

Parameter Measurement Information (continued)

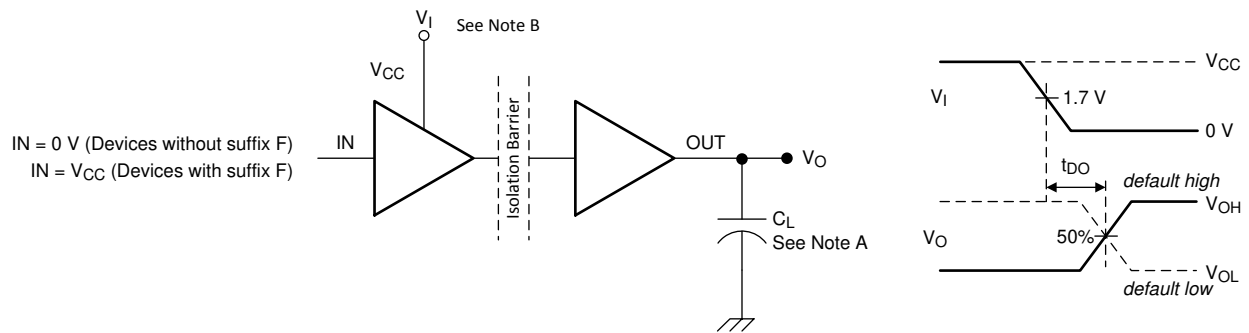

- A. C_L = 15 pF and includes instrumentation and fixture capacitance within ±20%.
- B. Power Supply Ramp Rate = 10 mV/ns

Figure 15. Default Output Delay Time Test Circuit and Voltage Waveforms

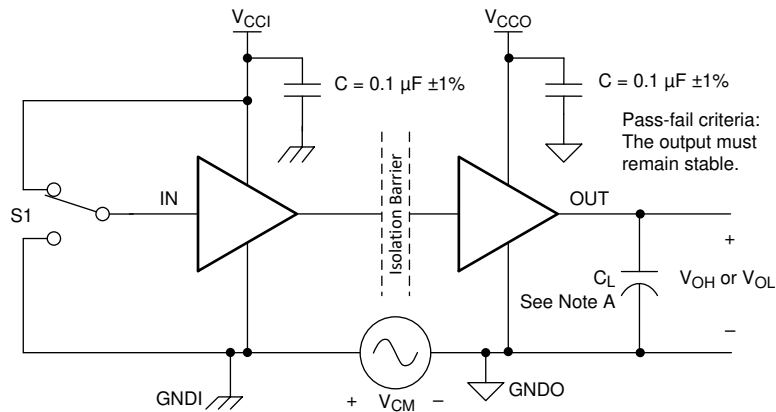

- A. C_L = 15 pF and includes instrumentation and fixture capacitance within ±20%.

Figure 16. Common-Mode Transient Immunity Test Circuit

9 Detailed Description

9.1 Overview

The ISO773x family of devices has an ON-OFF keying (OOK) modulation scheme to transmit the digital data across a silicon dioxide based isolation barrier. The transmitter sends a high frequency carrier across the barrier to represent one digital state and sends no signal to represent the other digital state. The receiver demodulates the signal after advanced signal conditioning and produces the output through a buffer stage. If the ENx pin is low then the output goes to high impedance. The ISO773x family of devices also incorporates advanced circuit techniques to maximize the CMTI performance and minimize the radiated emissions due to the high frequency carrier and IO buffer switching. The conceptual block diagram of a digital capacitive isolator, [Figure 17](#), shows a functional block diagram of a typical channel.

9.2 Functional Block Diagram

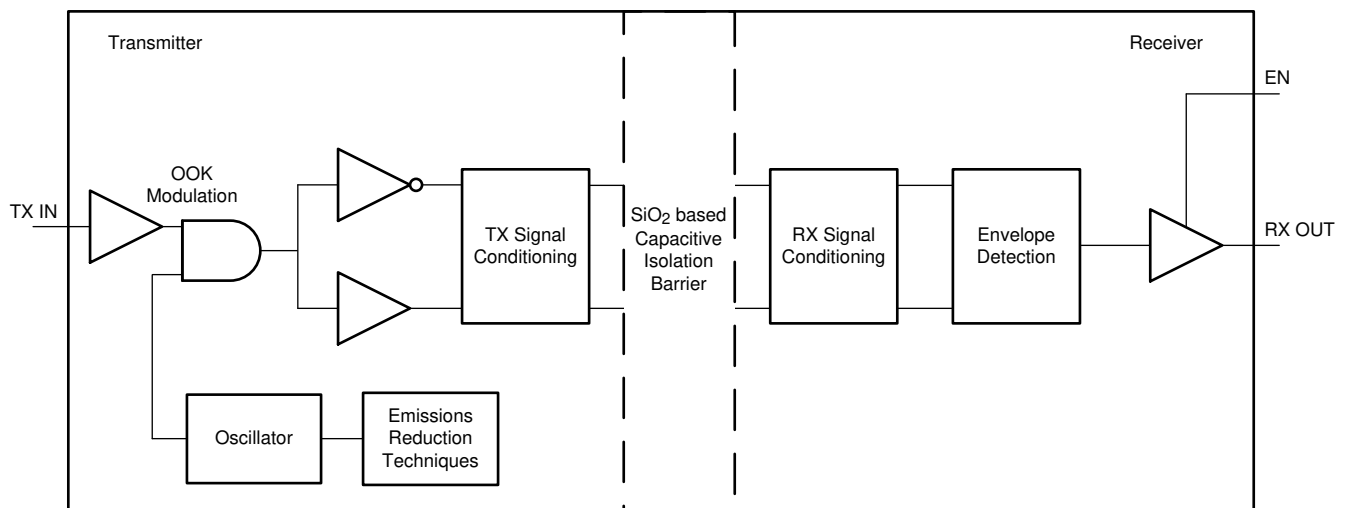

Copyright © 2016, Texas Instruments Incorporated

Figure 17. Conceptual Block Diagram of a Digital Capacitive Isolator

[Figure 18](#) shows a conceptual detail of how the ON-OFF keying scheme works.

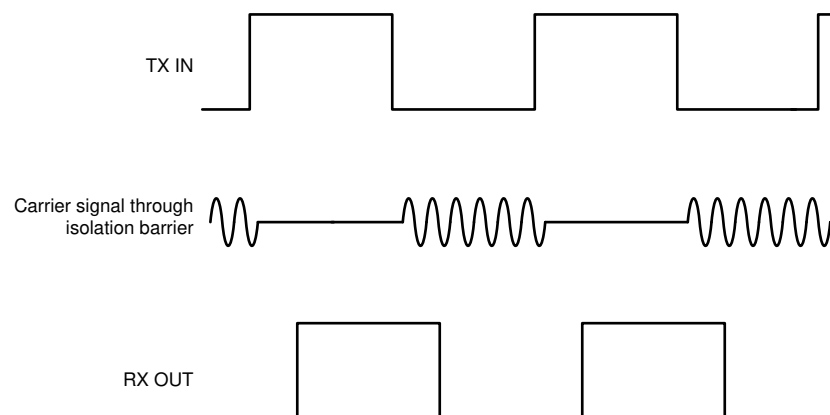

Figure 18. On-Off Keying (OOK) Based Modulation Scheme

9.3 Feature Description

Table 1 provides an overview of the device features.

Table 1. Device Features

PART NUMBER	CHANNEL DIRECTION	MAXIMUM DATA RATE	DEFAULT OUTPUT	PACKAGE	RATED ISOLATION ⁽¹⁾
ISO7730	3 Forward, 0 Reverse	100 Mbps	High	DW-16	5000 V _{RMS} / 8000 V _{PK}
				DBQ-16	3000 V _{RMS} / 4242 V _{PK}
ISO7730 with F suffix	3 Forward, 0 Reverse	100 Mbps	Low	DW-16	5000 V _{RMS} / 8000 V _{PK}
				DBQ-16	3000 V _{RMS} / 4242 V _{PK}
ISO7731	2 Forward, 1 Reverse	100 Mbps	High	DW-16	5000 V _{RMS} / 8000 V _{PK}
				DBQ-16	3000 V _{RMS} / 4242 V _{PK}
ISO7731 with F suffix	2 Forward, 1 Reverse	100 Mbps	Low	DW-16	5000 V _{RMS} / 8000 V _{PK}
				DBQ-16	3000 V _{RMS} / 4242 V _{PK}

(1) See [Safety-Related Certifications](#) for detailed isolation ratings.

9.3.1 Electromagnetic Compatibility (EMC) Considerations

Many applications in harsh industrial environment are sensitive to disturbances such as electrostatic discharge (ESD), electrical fast transient (EFT), surge and electromagnetic emissions. These electromagnetic disturbances are regulated by international standards such as IEC 61000-4-x and CISPR 22. Although system-level performance and reliability depends, to a large extent, on the application board design and layout, the ISO773x family of devices incorporates many chip-level design improvements for overall system robustness. Some of these improvements include:

- Robust ESD protection cells for input and output signal pins and inter-chip bond pads.
- Low-resistance connectivity of ESD cells to supply and ground pins.
- Enhanced performance of high voltage isolation capacitor for better tolerance of ESD, EFT and surge events.
- Bigger on-chip decoupling capacitors to bypass undesirable high energy signals through a low impedance path.
- PMOS and NMOS devices isolated from each other by using guard rings to avoid triggering of parasitic SCRs.
- Reduced common mode currents across the isolation barrier by ensuring purely differential internal operation.

9.4 Device Functional Modes

Table 2 lists the functional modes for the ISO773x devices.

Table 2. Function Table⁽¹⁾

V _{CCI}	V _{CCO}	INPUT (IN _x) ⁽²⁾	OUTPUT ENABLE (EN _x)	OUTPUT (OUT _x)	COMMENTS
PU	PU	H	H or open	H	Normal Operation: A channel output assumes the logic state of its input.
		L	H or open	L	
		Open	H or open	Default	Default mode: When IN _x is open, the corresponding channel output goes to its default logic state. Default is <i>High</i> for ISO773x and <i>Low</i> for ISO773x with F suffix.
X	PU	X	L	Z	A low value of Output Enable causes the outputs to be high-impedance
PD	PU	X	H or open	Default	Default mode: When V _{CCI} is unpowered, a channel output assumes the logic state based on the selected default option. Default is <i>High</i> for ISO773x and <i>Low</i> for ISO773x with F suffix. When V _{CCI} transitions from unpowered to powered-up, a channel output assumes the logic state of its input. When V _{CCI} transitions from powered-up to unpowered, channel output assumes the selected default state.
X	PD	X	X	Undetermined	When V _{CCO} is unpowered, a channel output is undetermined ⁽³⁾ . When V _{CCO} transitions from unpowered to powered-up, a channel output assumes the logic state of its input

- (1) V_{CCI} = Input-side V_{CC}; V_{CCO} = Output-side V_{CC}; PU = Powered up (V_{CC} ≥ 2.25 V); PD = Powered down (V_{CC} ≤ 1.7 V); X = Irrelevant; H = High level; L = Low level; Z = High Impedance
- (2) A strongly driven input signal can weakly power the floating V_{CC} via an internal protection diode and cause undetermined output.
- (3) The outputs are in undetermined state when 1.7 V < V_{CCI}, V_{CCO} < 2.25 V.

9.4.1 Device I/O Schematics

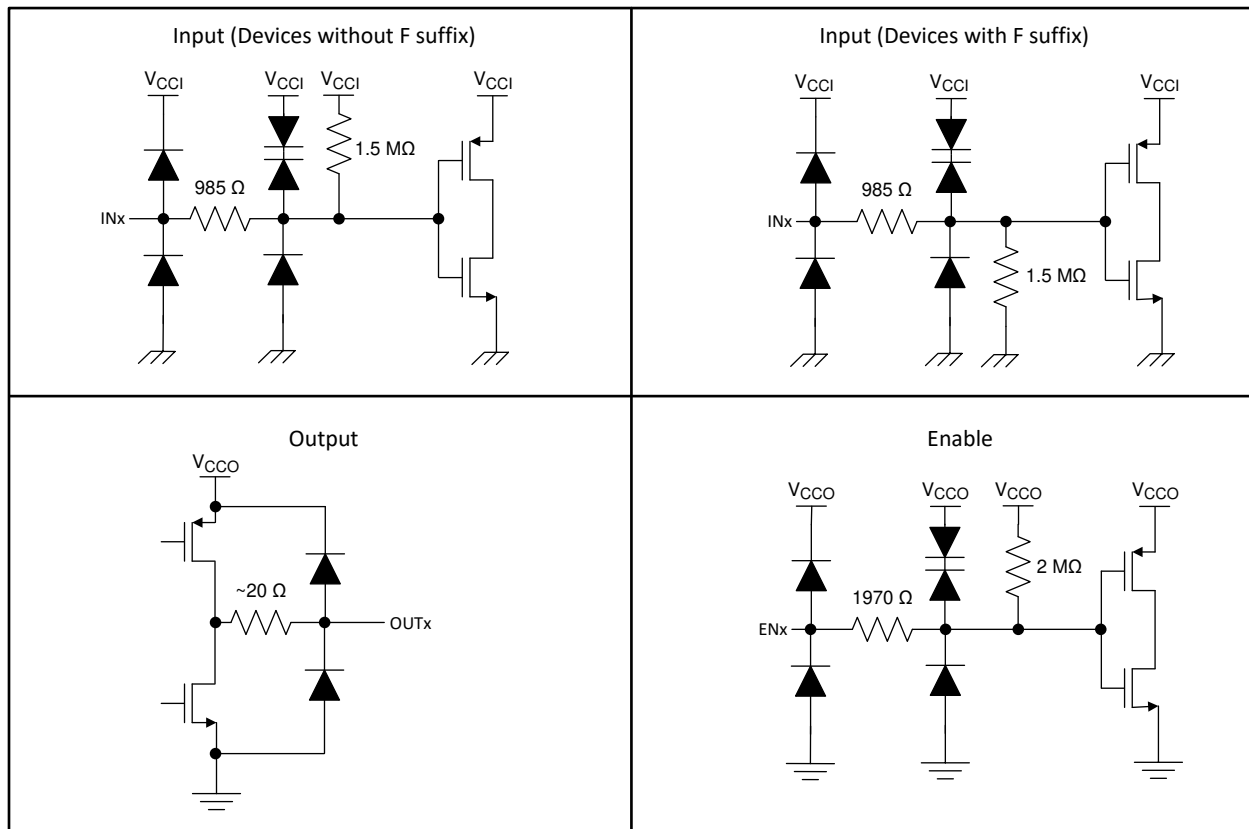

Copyright © 2016, Texas Instruments Incorporated

Figure 19. Device I/O Schematics

10 Application and Implementation

NOTE

Information in the following applications sections is not part of the TI component specification, and TI does not warrant its accuracy or completeness. TI's customers are responsible for determining suitability of components for their purposes. Customers should validate and test their design implementation to confirm system functionality.

10.1 Application Information

The ISO773x devices are high-performance, triple-channel digital isolators. These devices come with enable pins on each side which can be used to put the respective outputs in high impedance for multi-master driving applications and reduce power consumption. The ISO773x family of devices use single-ended CMOS-logic switching technology. The voltage range is from 2.25 V to 5.5 V for both supplies, V_{CC1} and V_{CC2} . When designing with digital isolators, keep in mind that because of the single-ended design structure, digital isolators do not conform to any specific interface standard and are only intended for isolating single-ended CMOS or TTL digital signal lines. The isolator is typically placed between the data controller (that is, μC or UART), and a data converter or a line transceiver, regardless of the interface type or standard.

10.2 Typical Application

The ISO7731 device, combined with Texas Instruments' mixed-signal microcontroller, RS-485 transceiver, transformer driver, and voltage regulator, can create an isolated RS-485 system as shown in [Figure 20](#).

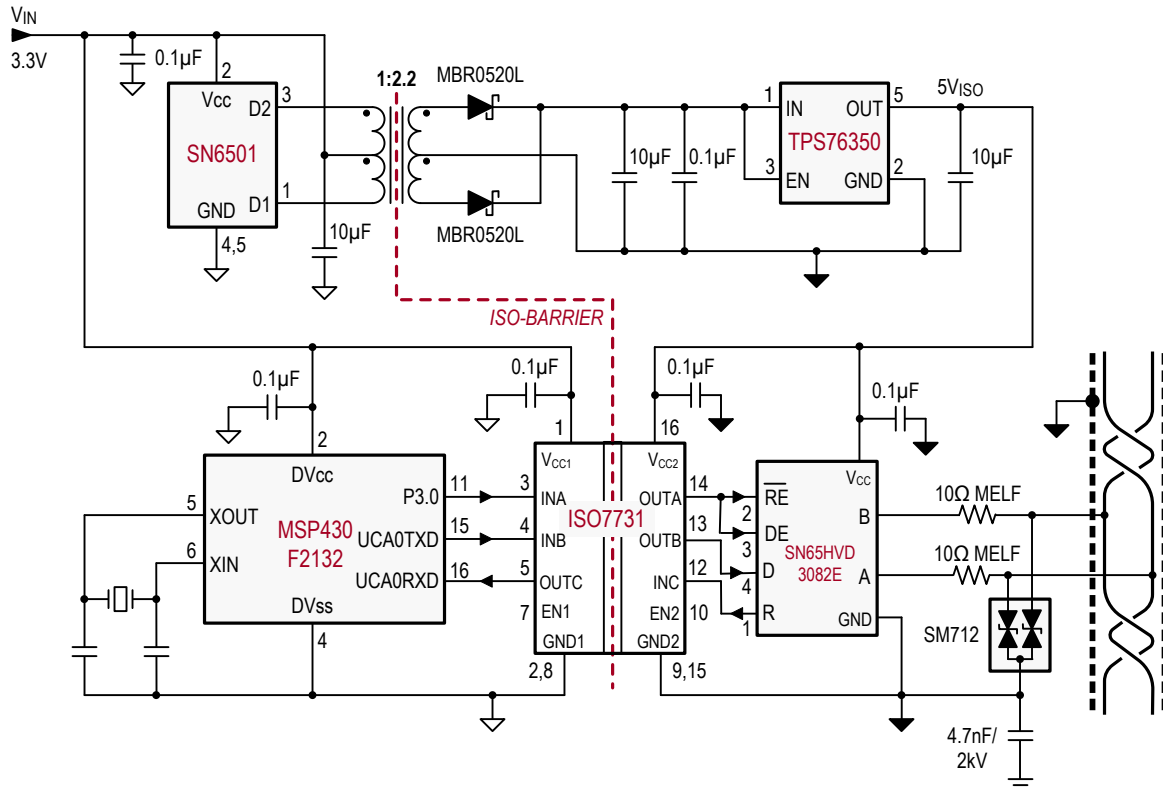

Copyright © 2016, Texas Instruments Incorporated

Figure 20. Isolated RS-485 Interface Circuit

Typical Application (continued)

10.2.1 Design Requirements

To design with these devices, use the parameters listed in [Table 3](#).

Table 3. Design Parameters

PARAMETER	VALUE
Supply voltage, V_{CC1} and V_{CC2}	2.25 to 5.5 V
Decoupling capacitor between V_{CC1} and GND1	0.1 μF
Decoupling capacitor from V_{CC2} and GND2	0.1 μF

10.2.2 Detailed Design Procedure

Unlike optocouplers, which require external components to improve performance, provide bias, or limit current, the ISO773x family of devices only requires two external bypass capacitors to operate. [Figure 21](#) and [Figure 22](#) show the typical circuit hook-up for the devices.

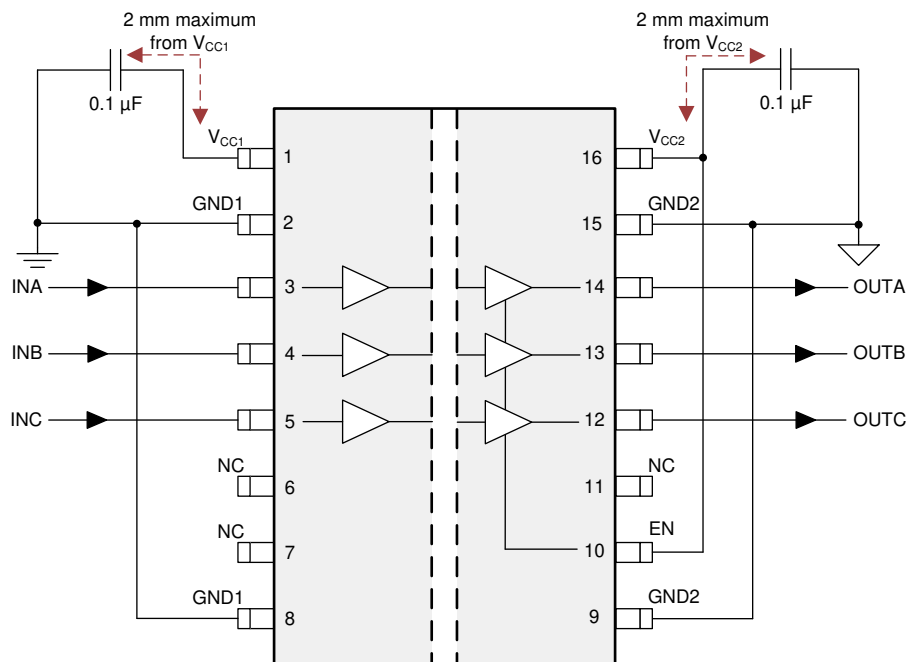

Figure 21. Typical ISO7730 Circuit Hook-Up

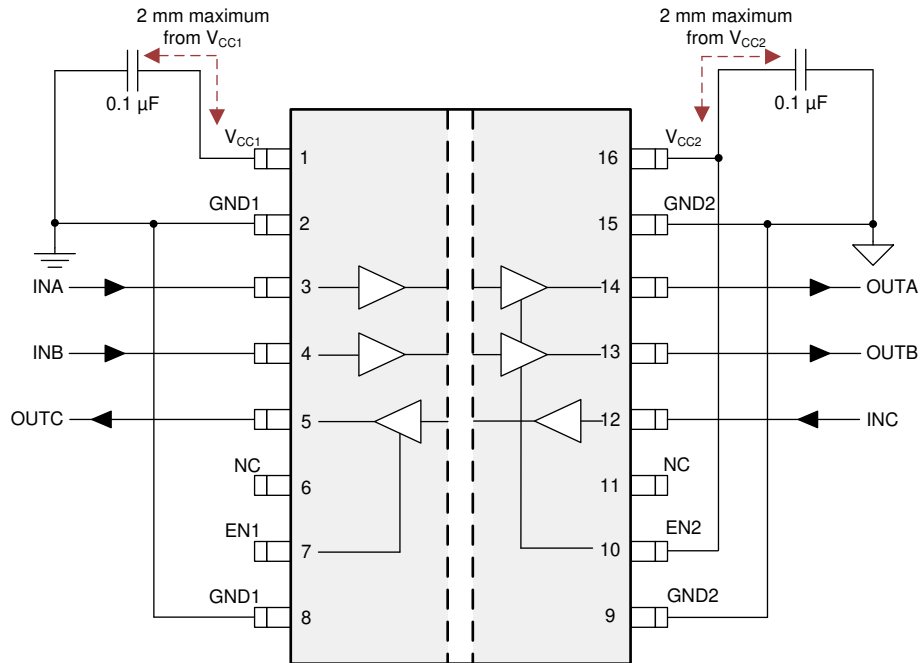
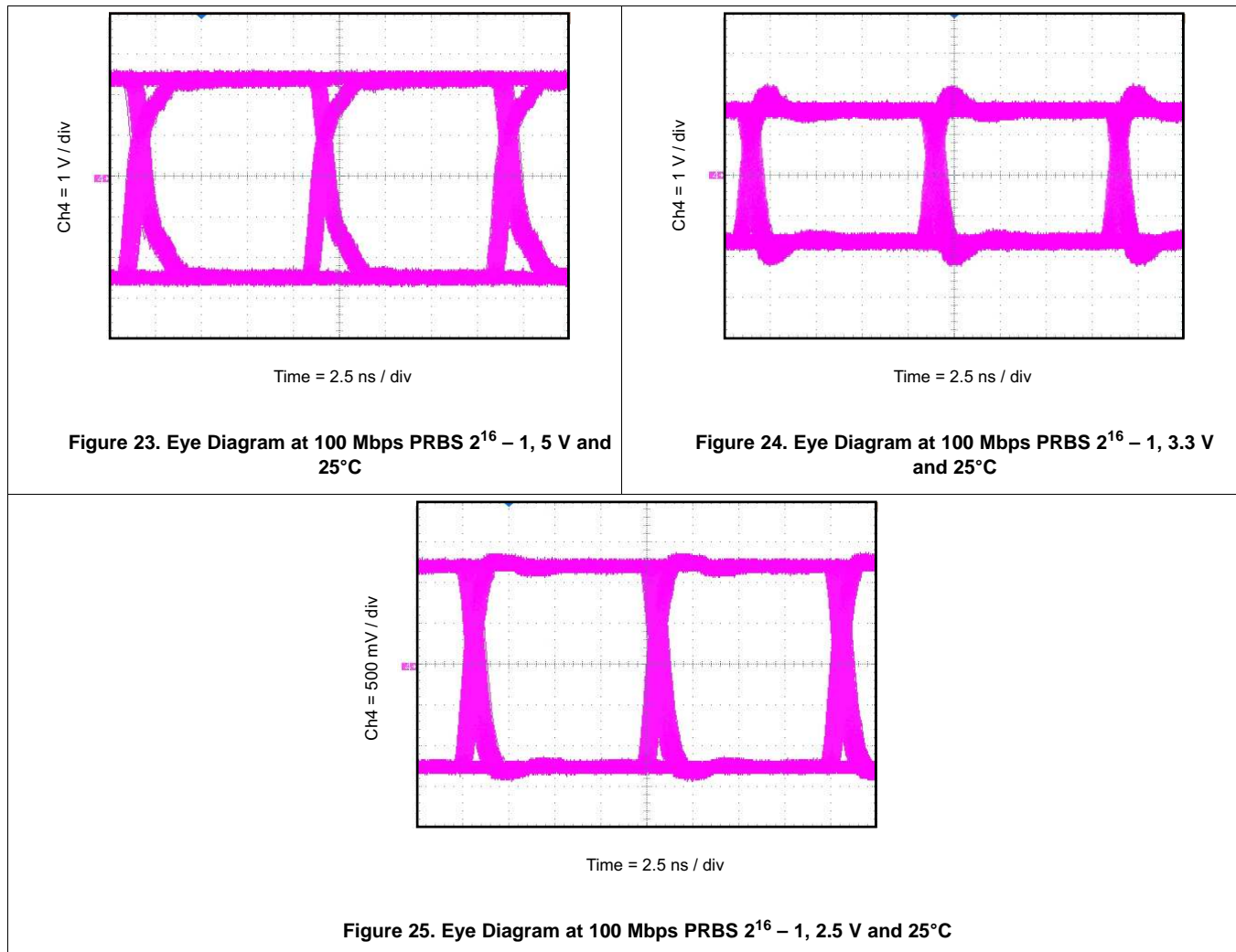

Figure 22. Typical ISO7731 Circuit Hook-Up

10.2.3 Application Curves

The following typical eye diagrams of the ISO773x family of devices indicate low jitter and wide open eye at the maximum data rate of 100 Mbps.



10.2.3.1 Insulation Lifetime

Insulation lifetime projection data is collected by using industry-standard Time Dependent Dielectric Breakdown (TDDB) test method. In this test, all pins on each side of the barrier are tied together creating a two-terminal device and high voltage applied between the two sides; See [Figure 26](#) for TDDB test setup. The insulation breakdown data is collected at various high voltages switching at 60 Hz over temperature. For reinforced insulation, VDE standard requires the use of TDDB projection line with failure rate of less than 1 part per million (ppm). Even though the expected minimum insulation lifetime is 20 years at the specified working isolation voltage, VDE reinforced certification requires additional safety margin of 20% for working voltage and 87.5% for lifetime which translates into minimum required insulation lifetime of 37.5 years at a working voltage that's 20% higher than the specified value.

[Figure 27](#) shows the intrinsic capability of the isolation barrier to withstand high voltage stress over its lifetime. Based on the TDDB data, the intrinsic capability of the insulation is 1500 V_{RMS} with a lifetime of 135 years. Other factors, such as package size, pollution degree, material group, etc. can further limit the working voltage of the component. The working voltage of DW-16 package is specified upto 1500 V_{RMS} and DBQ-16 package up to 400 V_{RMS}. At the lower working voltages, the corresponding insulation lifetime is much longer than 135 years.

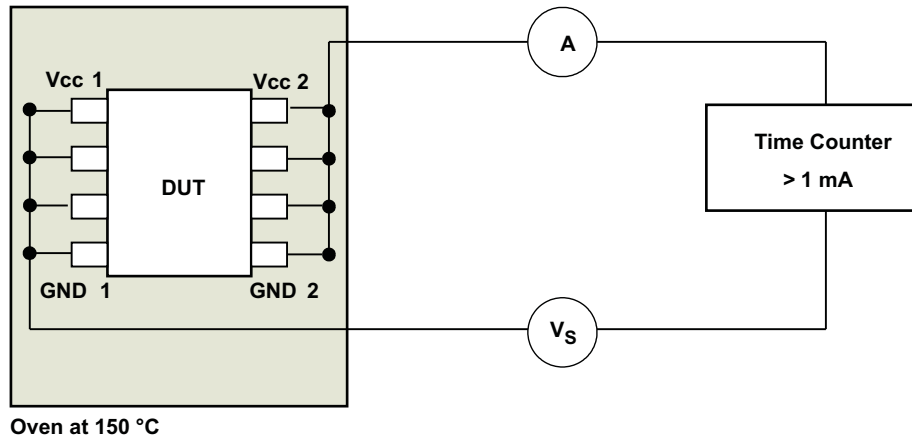

Figure 26. Test Setup for Insulation Lifetime Measurement

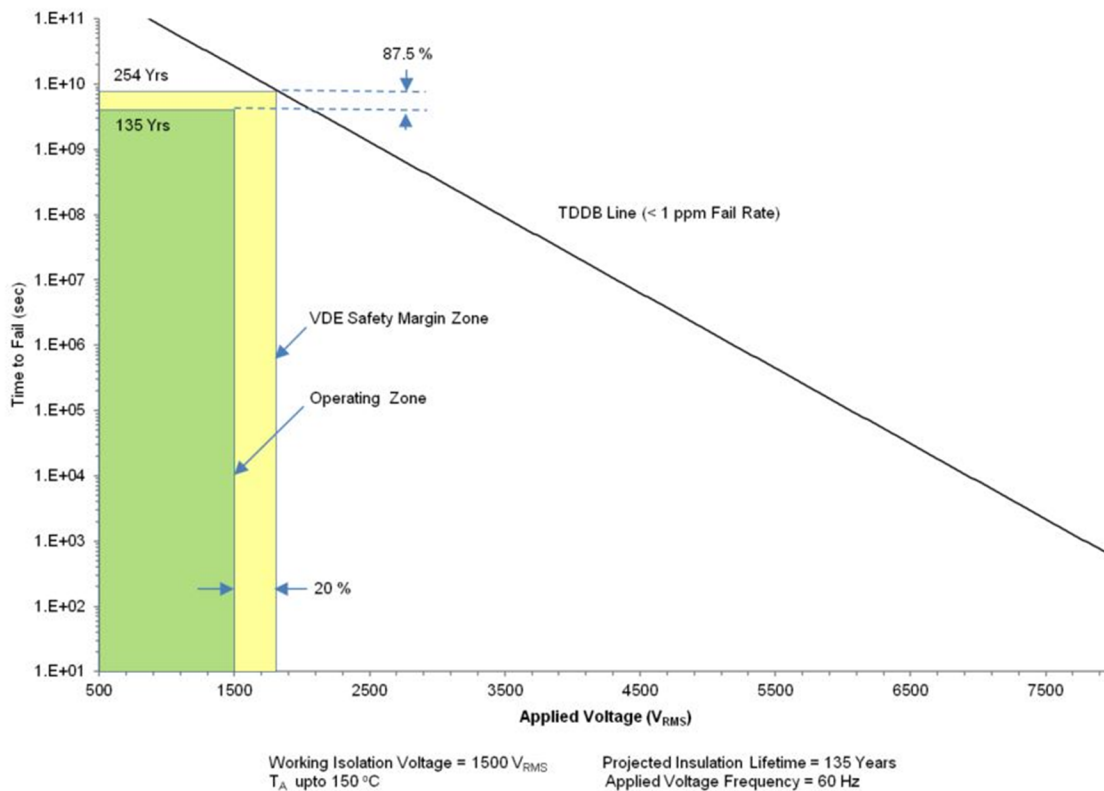

Figure 27. Insulation Lifetime Projection Data

11 Power Supply Recommendations

To help ensure reliable operation at data rates and supply voltages, a 0.1- μ F bypass capacitor is recommended at the input and output supply pins (V_{CC1} and V_{CC2}). The capacitors should be placed as close to the supply pins as possible. If only a single primary-side power supply is available in an application, isolated power can be generated for the secondary-side with the help of a transformer driver such as Texas Instruments' [SN6501](#) or [SN6505A](#). For such applications, detailed power supply design and transformer selection recommendations are available in the [SN6501 Transformer Driver for Isolated Power Supplies data sheet](#) or [SN6505A Low-Noise 1-A Transformer Drivers for Isolated Power Supplies](#) (SLLSEP9).

12 Layout

12.1 Layout Guidelines

A minimum of four layers is required to accomplish a low EMI PCB design (see [Figure 28](#)). Layer stacking should be in the following order (top-to-bottom): high-speed signal layer, ground plane, power plane and low-frequency signal layer.

- Routing the high-speed traces on the top layer avoids the use of vias (and the introduction of their inductances) and allows for clean interconnects between the isolator and the transmitter and receiver circuits of the data link.
- Placing a solid ground plane next to the high-speed signal layer establishes controlled impedance for transmission line interconnects and provides an excellent low-inductance path for the return current flow.
- Placing the power plane next to the ground plane creates additional high-frequency bypass capacitance of approximately 100 pF/inch².
- Routing the slower speed control signals on the bottom layer allows for greater flexibility as these signal links usually have margin to tolerate discontinuities such as vias.

If an additional supply voltage plane or signal layer is needed, add a second power or ground plane system to the stack to keep it symmetrical. This makes the stack mechanically stable and prevents it from warping. Also the power and ground plane of each power system can be placed closer together, thus increasing the high-frequency bypass capacitance significantly.

For detailed layout recommendations, refer to the [Digital Isolator Design Guide](#).

12.1.1 PCB Material

For digital circuit boards operating below 150 Mbps, (or rise and fall times higher than 1 ns), and trace lengths of up to 10 inches, use standard FR-4 UL94V-0 printed circuit boards. This PCB is preferred over cheaper alternatives due to its lower dielectric losses at high frequencies, less moisture absorption, greater strength and stiffness, and self-extinguishing flammability-characteristics.

12.2 Layout Example

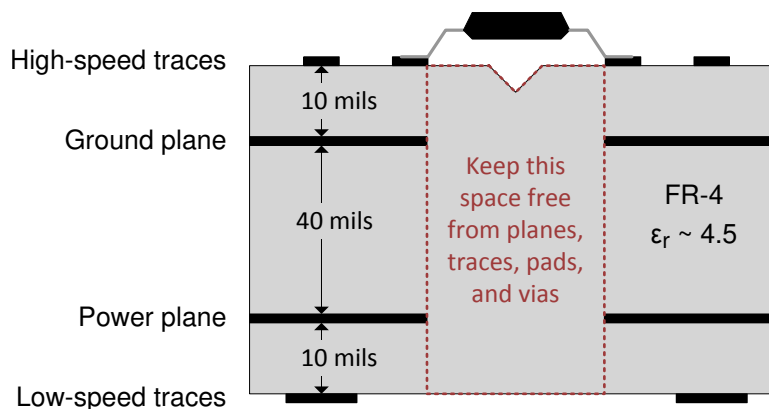

Figure 28. Layout Example Schematic

13 器件和文档支持

13.1 文档支持

13.1.1 相关文档

请参阅如下相关文档：

- 德州仪器 (TI), [《数字隔离器设计指南》](#)
- 德州仪器 (TI), [《隔离相关术语》](#)
- 德州仪器 (TI), [《如何通过隔离改善工业系统的 ESD、EFT 和浪涌抗扰性》应用报告](#) 如何通过隔离改善工业系统的 ESD、EFT 和浪涌抗扰性”应用报告
- 德州仪器 (TI), [《SN6501 用于隔离式电源的变压器驱动器》数据表](#)
- 德州仪器 (TI), [《SNx5HVD308xE 采用小型 MSOP-8 封装的低功耗 RS-485 收发器》数据表](#)
- 德州仪器 (TI), [TPS76350 《低功耗 150mA 低压降线性稳压器》数据表](#)
- 德州仪器 (TI), [MSP430F2132 《混合信号微控制器》数据表](#)

13.2 相关链接

下表列出了快速访问链接。类别包括技术文档、支持与社区资源、工具和软件，以及申请样片或购买产品的快速链接。

表 4. 相关链接

器件	产品文件夹	立即订购	技术文档	工具与软件	支持和社区
ISO7730	请单击此处	请单击此处	请单击此处	请单击此处	请单击此处
ISO7731	请单击此处	请单击此处	请单击此处	请单击此处	请单击此处

13.3 接收文档更新通知

要接收文档更新通知，请导航至 TI.com.cn 上的器件产品文件夹。单击右上角的 [通知我](#) 进行注册，即可每周接收产品信息更改摘要。有关更改的详细信息，请查看任何已修订文档中包含的修订历史记录。

13.4 社区资源

The following links connect to TI community resources. Linked contents are provided "AS IS" by the respective contributors. They do not constitute TI specifications and do not necessarily reflect TI's views; see TI's [Terms of Use](#).

TI E2E™ Online Community *TI's Engineer-to-Engineer (E2E) Community*. Created to foster collaboration among engineers. At e2e.ti.com, you can ask questions, share knowledge, explore ideas and help solve problems with fellow engineers.

Design Support *TI's Design Support* Quickly find helpful E2E forums along with design support tools and contact information for technical support.

13.5 商标

E2E is a trademark of Texas Instruments.
All other trademarks are the property of their respective owners.

13.6 静电放电警告



ESD 可能会损坏该集成电路。德州仪器 (TI) 建议通过适当的预防措施处理所有集成电路。如果不遵守正确的处理措施和安装程序，可能会损坏集成电路。

ESD 的损坏小至导致微小的性能降级，大至整个器件故障。精密的集成电路可能更容易受到损坏，这是因为非常细微的参数更改都可能会导致器件与其发布的规格不相符。

13.7 Glossary

[SLYZ022](#) — *TI Glossary*.

This glossary lists and explains terms, acronyms, and definitions.

14 机械、封装和可订购信息

以下页面包含机械、封装和可订购信息。这些信息是指定器件的最新可用数据。数据如有变更，恕不另行通知，且不会对此文档进行修订。如需获取此数据表的浏览器版本，请查阅左侧的导航栏。



DW0016B

PACKAGE OUTLINE

SOIC - 2.65 mm max height

SOIC

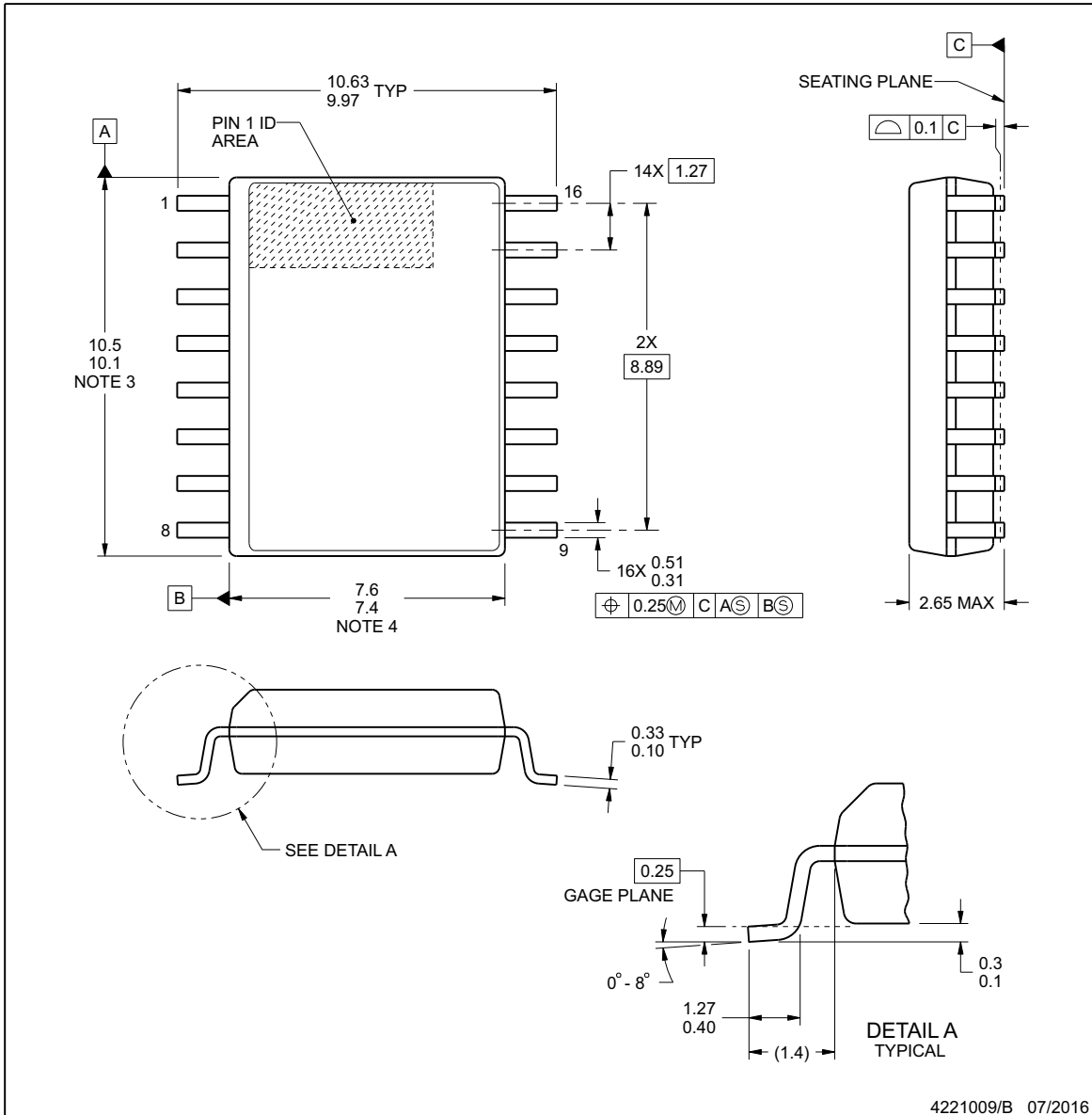

4221009/B 07/2016

NOTES:

1. All linear dimensions are in millimeters. Dimensions in parenthesis are for reference only. Dimensioning and tolerancing per ASME Y14.5M.
2. This drawing is subject to change without notice.
3. This dimension does not include mold flash, protrusions, or gate burrs. Mold flash, protrusions, or gate burrs shall not exceed 0.15 mm, per side.
4. This dimension does not include interlead flash. Interlead flash shall not exceed 0.25 mm, per side.
5. Reference JEDEC registration MS-013.

EXAMPLE BOARD LAYOUT

DW0016B

SOIC - 2.65 mm max height

SOIC

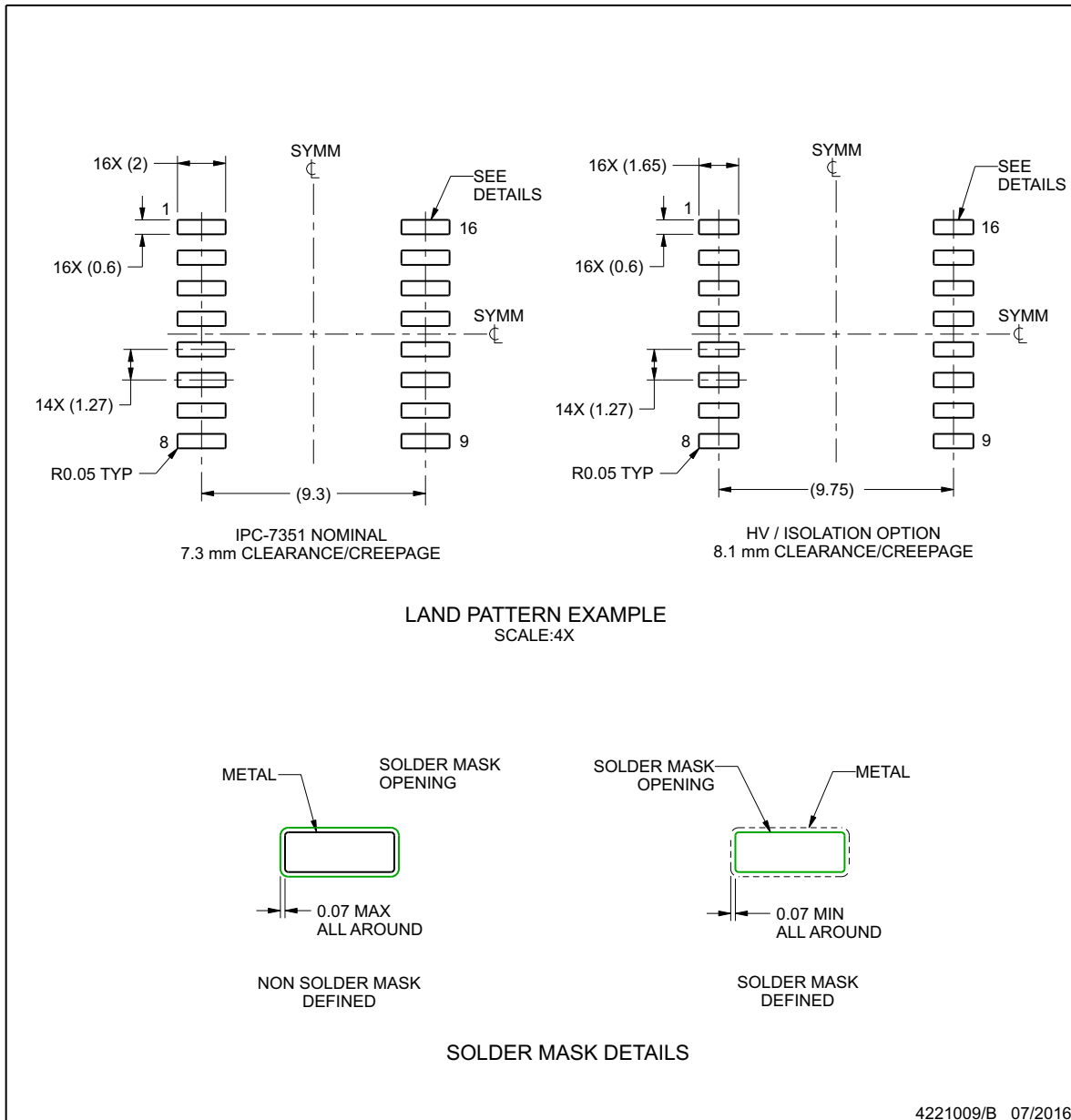

NOTES: (continued)

6. Publication IPC-7351 may have alternate designs.

7. Solder mask tolerances between and around signal pads can vary based on board fabrication site.

EXAMPLE STENCIL DESIGN

DW0016B

SOIC - 2.65 mm max height

SOIC

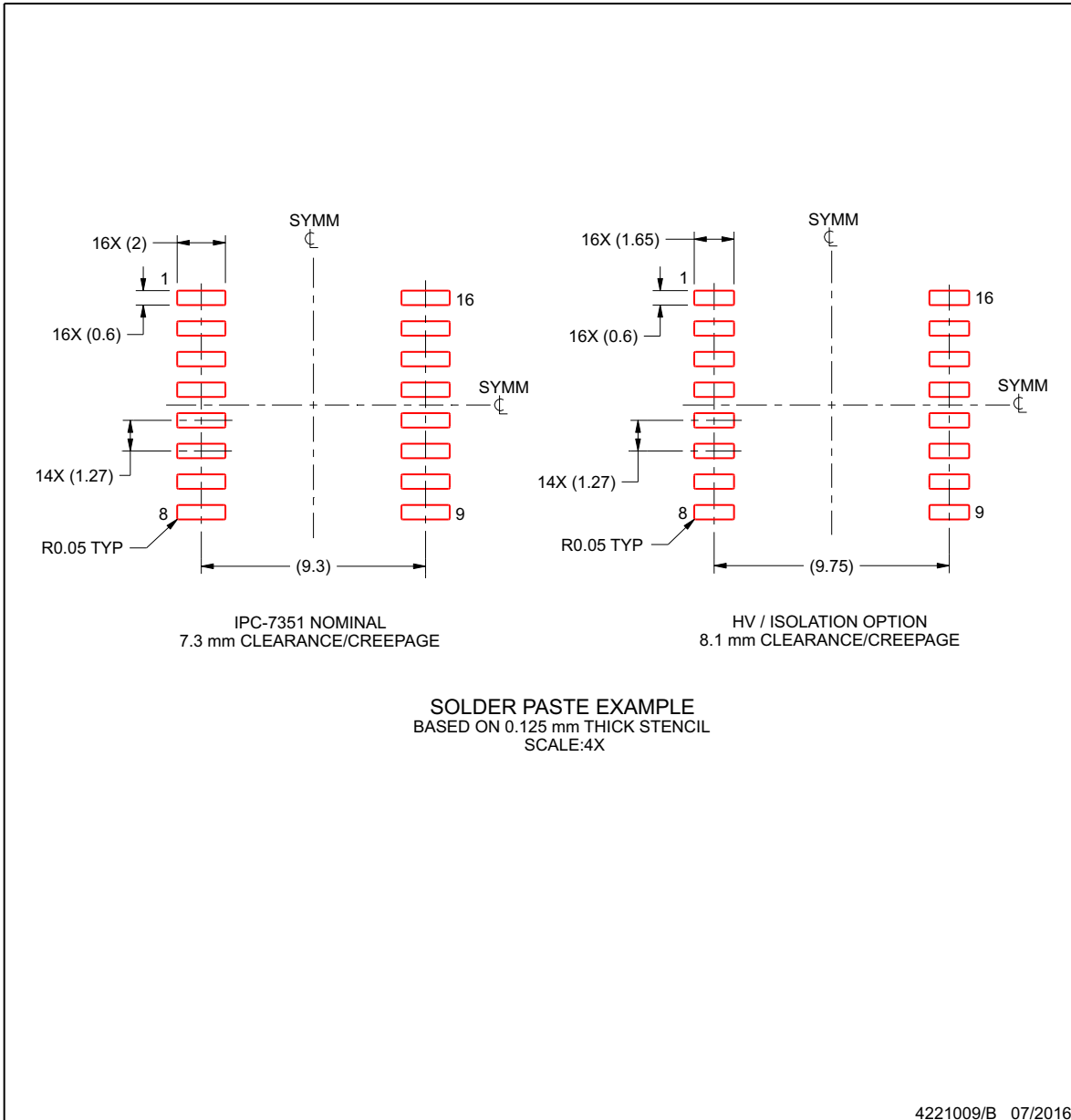

NOTES: (continued)

8. Laser cutting apertures with trapezoidal walls and rounded corners may offer better paste release. IPC-7525 may have alternate design recommendations.
9. Board assembly site may have different recommendations for stencil design.

DBQ0016A
PACKAGE OUTLINE
SSOP - 1.75 mm max height

SHRINK SMALL-OUTLINE PACKAGE

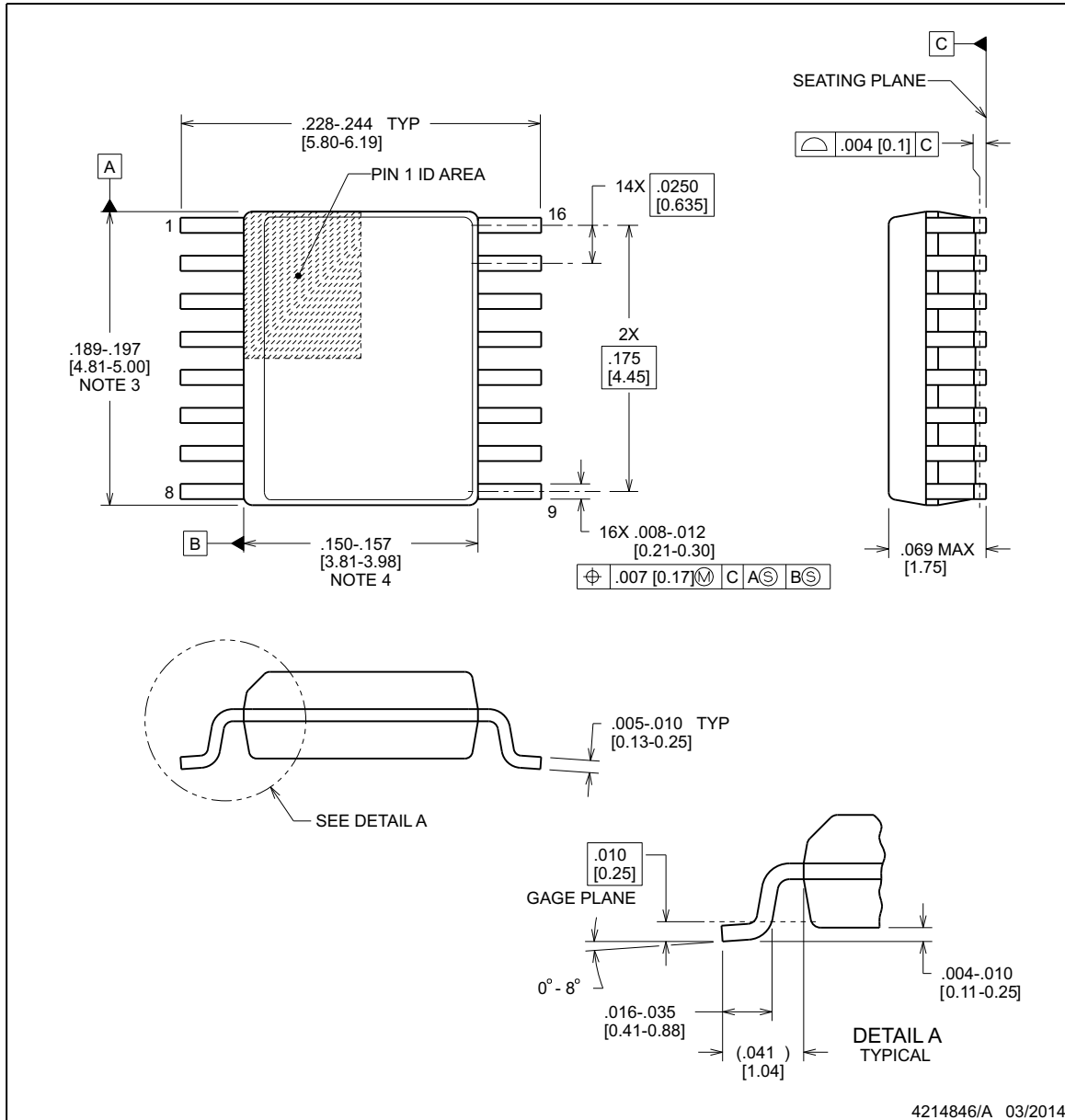
NOTES:

1. Linear dimensions are in inches [millimeters]. Dimensions in parenthesis are for reference only. Controlling dimensions are in inches. Dimensioning and tolerancing per ASME Y14.5M.
2. This drawing is subject to change without notice.
3. This dimension does not include mold flash, protrusions, or gate burrs. Mold flash, protrusions, or gate burrs shall not exceed .006 inch, per side.
4. This dimension does not include interlead flash.
5. Reference JEDEC registration MO-137, variation AB.

EXAMPLE BOARD LAYOUT

DBQ0016A

SSOP - 1.75 mm max height

SHRINK SMALL-OUTLINE PACKAGE

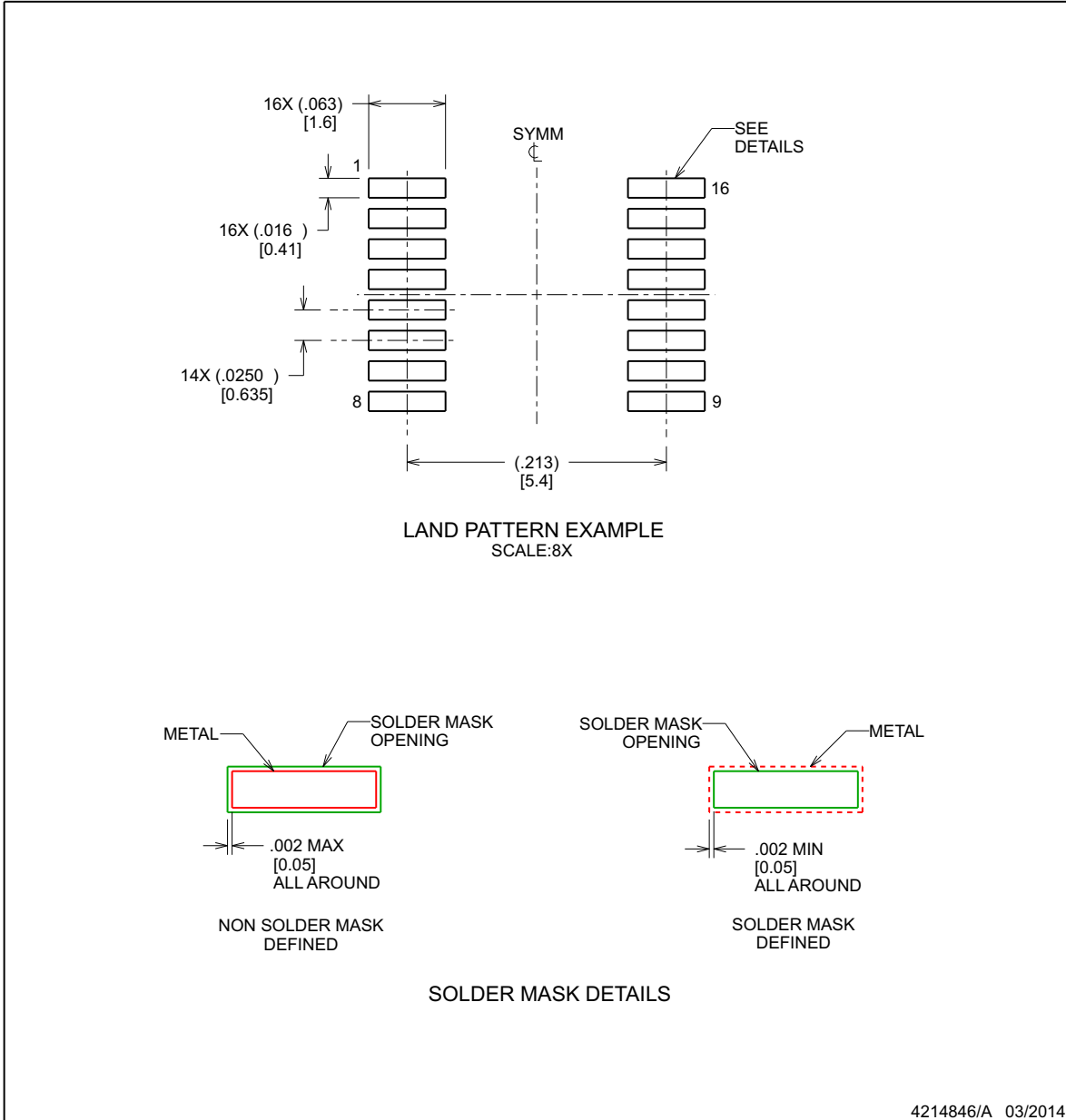

NOTES: (continued)

- 6. Publication IPC-7351 may have alternate designs.
- 7. Solder mask tolerances between and around signal pads can vary based on board fabrication site.

EXAMPLE STENCIL DESIGN

DBQ0016A

SSOP - 1.75 mm max height

SHRINK SMALL-OUTLINE PACKAGE

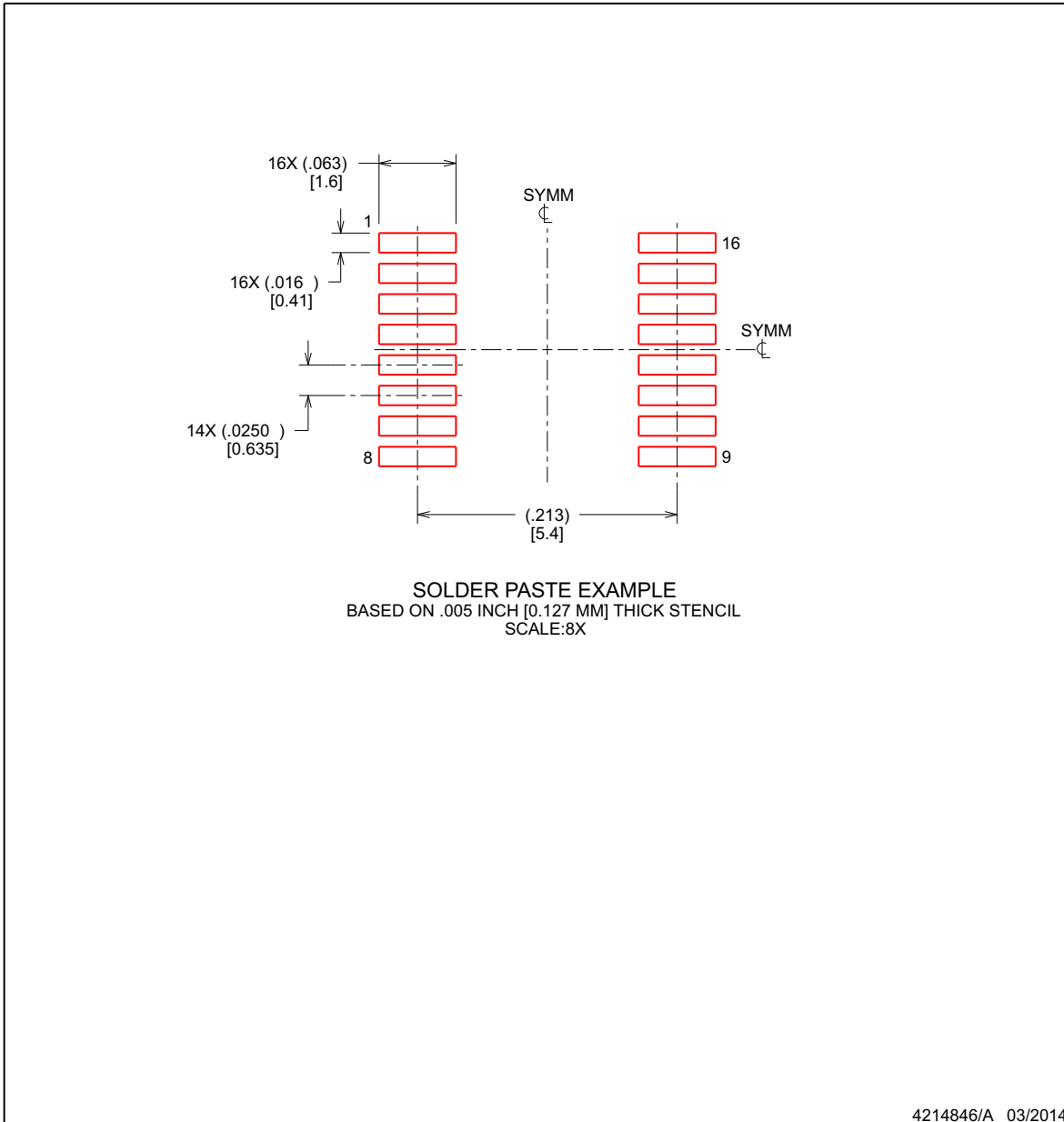

NOTES: (continued)

- 8. Laser cutting apertures with trapezoidal walls and rounded corners may offer better paste release. IPC-7525 may have alternate design recommendations.
- 9. Board assembly site may have different recommendations for stencil design.

PACKAGING INFORMATION

Orderable Device	Status (1)	Package Type	Package Drawing	Pins	Package Qty	Eco Plan (2)	Lead finish/ Ball material (6)	MSL Peak Temp (3)	Op Temp (°C)	Device Marking (4/5)	Samples
ISO7730DBQ	ACTIVE	SSOP	DBQ	16	75	RoHS & Green	NIPDAU	Level-2-260C-1 YEAR	-55 to 125	7730	Samples
ISO7730DBQR	ACTIVE	SSOP	DBQ	16	2500	RoHS & Green	NIPDAU	Level-2-260C-1 YEAR	-55 to 125	7730	Samples
ISO7730DW	ACTIVE	SOIC	DW	16	40	RoHS & Green	NIPDAU	Level-2-260C-1 YEAR	-55 to 125	ISO7730	Samples
ISO7730DWR	ACTIVE	SOIC	DW	16	2000	RoHS & Green	NIPDAU	Level-2-260C-1 YEAR	-55 to 125	ISO7730	Samples
ISO7730FDBQ	ACTIVE	SSOP	DBQ	16	75	RoHS & Green	NIPDAU	Level-2-260C-1 YEAR	-55 to 125	7730F	Samples
ISO7730FDBQR	ACTIVE	SSOP	DBQ	16	2500	RoHS & Green	NIPDAU	Level-2-260C-1 YEAR	-55 to 125	7730F	Samples
ISO7730FDW	ACTIVE	SOIC	DW	16	40	RoHS & Green	NIPDAU	Level-2-260C-1 YEAR	-55 to 125	ISO7730F	Samples
ISO7730FDWR	ACTIVE	SOIC	DW	16	2000	RoHS & Green	NIPDAU	Level-2-260C-1 YEAR	-55 to 125	ISO7730F	Samples
ISO7731BDW	ACTIVE	SOIC	DW	16	40	RoHS & Green	NIPDAU	Level-2-260C-1 YEAR	-55 to 125	ISO7731B	Samples
ISO7731BDWR	ACTIVE	SOIC	DW	16	2000	RoHS & Green	NIPDAU	Level-2-260C-1 YEAR	-55 to 125	ISO7731B	Samples
ISO7731DBQ	ACTIVE	SSOP	DBQ	16	75	RoHS & Green	NIPDAU	Level-2-260C-1 YEAR	-55 to 125	7731	Samples
ISO7731DBQR	ACTIVE	SSOP	DBQ	16	2500	RoHS & Green	NIPDAU	Level-2-260C-1 YEAR	-55 to 125	7731	Samples
ISO7731DW	ACTIVE	SOIC	DW	16	40	RoHS & Green	NIPDAU	Level-2-260C-1 YEAR	-55 to 125	ISO7731	Samples
ISO7731DWR	ACTIVE	SOIC	DW	16	2000	RoHS & Green	NIPDAU	Level-2-260C-1 YEAR	-55 to 125	ISO7731	Samples
ISO7731FBDW	ACTIVE	SOIC	DW	16	40	RoHS & Green	NIPDAU	Level-2-260C-1 YEAR	-55 to 125	ISO7731FB	Samples
ISO7731FBDWR	ACTIVE	SOIC	DW	16	2000	RoHS & Green	NIPDAU	Level-2-260C-1 YEAR	-55 to 125	ISO7731FB	Samples
ISO7731FDBQ	ACTIVE	SSOP	DBQ	16	75	RoHS & Green	NIPDAU	Level-2-260C-1 YEAR	-55 to 125	7731F	Samples
ISO7731FDBQR	ACTIVE	SSOP	DBQ	16	2500	RoHS & Green	NIPDAU	Level-2-260C-1 YEAR	-55 to 125	7731F	Samples
ISO7731FDW	ACTIVE	SOIC	DW	16	40	RoHS & Green	NIPDAU	Level-2-260C-1 YEAR	-55 to 125	ISO7731F	Samples
ISO7731FDWR	ACTIVE	SOIC	DW	16	2000	RoHS & Green	NIPDAU	Level-2-260C-1 YEAR	-55 to 125	ISO7731F	Samples

(1) The marketing status values are defined as follows:

ACTIVE: Product device recommended for new designs.

LIFEBUY: TI has announced that the device will be discontinued, and a lifetime-buy period is in effect.

NRND: Not recommended for new designs. Device is in production to support existing customers, but TI does not recommend using this part in a new design.

PREVIEW: Device has been announced but is not in production. Samples may or may not be available.

OBSOLETE: TI has discontinued the production of the device.

(2) **RoHS:** TI defines "RoHS" to mean semiconductor products that are compliant with the current EU RoHS requirements for all 10 RoHS substances, including the requirement that RoHS substance do not exceed 0.1% by weight in homogeneous materials. Where designed to be soldered at high temperatures, "RoHS" products are suitable for use in specified lead-free processes. TI may reference these types of products as "Pb-Free".

RoHS Exempt: TI defines "RoHS Exempt" to mean products that contain lead but are compliant with EU RoHS pursuant to a specific EU RoHS exemption.

Green: TI defines "Green" to mean the content of Chlorine (Cl) and Bromine (Br) based flame retardants meet JS709B low halogen requirements of ≤ 1000 ppm threshold. Antimony trioxide based flame retardants must also meet the ≤ 1000 ppm threshold requirement.

(3) MSL, Peak Temp. - The Moisture Sensitivity Level rating according to the JEDEC industry standard classifications, and peak solder temperature.

(4) There may be additional marking, which relates to the logo, the lot trace code information, or the environmental category on the device.

(5) Multiple Device Markings will be inside parentheses. Only one Device Marking contained in parentheses and separated by a "~" will appear on a device. If a line is indented then it is a continuation of the previous line and the two combined represent the entire Device Marking for that device.

(6) Lead finish/Ball material - Orderable Devices may have multiple material finish options. Finish options are separated by a vertical ruled line. Lead finish/Ball material values may wrap to two lines if the finish value exceeds the maximum column width.

Important Information and Disclaimer:The information provided on this page represents TI's knowledge and belief as of the date that it is provided. TI bases its knowledge and belief on information provided by third parties, and makes no representation or warranty as to the accuracy of such information. Efforts are underway to better integrate information from third parties. TI has taken and continues to take reasonable steps to provide representative and accurate information but may not have conducted destructive testing or chemical analysis on incoming materials and chemicals. TI and TI suppliers consider certain information to be proprietary, and thus CAS numbers and other limited information may not be available for release.

In no event shall TI's liability arising out of such information exceed the total purchase price of the TI part(s) at issue in this document sold by TI to Customer on an annual basis.

TAPE AND REEL INFORMATION

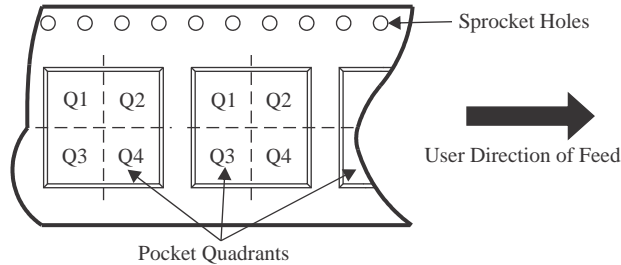
QUADRANT ASSIGNMENTS FOR PIN 1 ORIENTATION IN TAPE

*All dimensions are nominal

Device	Package Type	Package Drawing	Pins	SPQ	Reel Diameter (mm)	Reel Width W1 (mm)	A0 (mm)	B0 (mm)	K0 (mm)	P1 (mm)	W (mm)	Pin1 Quadrant
ISO7730DBQR	SSOP	DBQ	16	2500	330.0	12.4	6.4	5.2	2.1	8.0	12.0	Q1
ISO7730DWR	SOIC	DW	16	2000	330.0	16.4	10.75	10.7	2.7	12.0	16.0	Q1
ISO7730DWR	SOIC	DW	16	2000	330.0	16.4	10.75	10.7	2.7	12.0	16.0	Q1
ISO7730DWR	SOIC	DW	16	2000	330.0	16.4	10.75	10.7	2.7	12.0	16.0	Q1
ISO7730FDBQR	SSOP	DBQ	16	2500	330.0	12.4	6.4	5.2	2.1	8.0	12.0	Q1
ISO7730FDWR	SOIC	DW	16	2000	330.0	16.4	10.75	10.7	2.7	12.0	16.0	Q1
ISO7730FDWR	SOIC	DW	16	2000	330.0	16.4	10.75	10.7	2.7	12.0	16.0	Q1
ISO7730FDWR	SOIC	DW	16	2000	330.0	16.4	10.75	10.7	2.7	12.0	16.0	Q1
ISO7731BDWR	SOIC	DW	16	2000	330.0	16.4	10.75	10.7	2.7	12.0	16.0	Q1
ISO7731BDWR	SOIC	DW	16	2000	330.0	16.4	10.75	10.7	2.7	12.0	16.0	Q1
ISO7731BDWR	SOIC	DW	16	2000	330.0	16.4	10.75	10.7	2.7	12.0	16.0	Q1
ISO7731DBQR	SSOP	DBQ	16	2500	330.0	12.4	6.4	5.2	2.1	8.0	12.0	Q1
ISO7731DWR	SOIC	DW	16	2000	330.0	16.4	10.75	10.7	2.7	12.0	16.0	Q1
ISO7731DWR	SOIC	DW	16	2000	330.0	16.4	10.75	10.7	2.7	12.0	16.0	Q1
ISO7731DWR	SOIC	DW	16	2000	330.0	16.4	10.75	10.7	2.7	12.0	16.0	Q1
ISO7731FBDWR	SOIC	DW	16	2000	330.0	16.4	10.75	10.7	2.7	12.0	16.0	Q1

Device	Package Type	Package Drawing	Pins	SPQ	Reel Diameter (mm)	Reel Width W1 (mm)	A0 (mm)	B0 (mm)	K0 (mm)	P1 (mm)	W (mm)	Pin1 Quadrant
ISO7731FBDWR	SOIC	DW	16	2000	330.0	16.4	10.75	10.7	2.7	12.0	16.0	Q1
ISO7731FBDWR	SOIC	DW	16	2000	330.0	16.4	10.75	10.7	2.7	12.0	16.0	Q1
ISO7731FDBQR	SSOP	DBQ	16	2500	330.0	12.4	6.4	5.2	2.1	8.0	12.0	Q1
ISO7731FDWR	SOIC	DW	16	2000	330.0	16.4	10.75	10.7	2.7	12.0	16.0	Q1
ISO7731FDWR	SOIC	DW	16	2000	330.0	16.4	10.75	10.7	2.7	12.0	16.0	Q1
ISO7731FDWR	SOIC	DW	16	2000	330.0	16.4	10.75	10.7	2.7	12.0	16.0	Q1

TAPE AND REEL BOX DIMENSIONS

*All dimensions are nominal

Device	Package Type	Package Drawing	Pins	SPQ	Length (mm)	Width (mm)	Height (mm)
ISO7730DBQR	SSOP	DBQ	16	2500	350.0	350.0	43.0
ISO7730DWR	SOIC	DW	16	2000	350.0	350.0	43.0
ISO7730DWR	SOIC	DW	16	2000	367.0	367.0	38.0
ISO7730DWR	SOIC	DW	16	2000	367.0	367.0	38.0
ISO7730FDBQR	SSOP	DBQ	16	2500	350.0	350.0	43.0
ISO7730FDWR	SOIC	DW	16	2000	367.0	367.0	38.0
ISO7730FDWR	SOIC	DW	16	2000	350.0	350.0	43.0
ISO7730FDWR	SOIC	DW	16	2000	367.0	367.0	38.0
ISO7731BDWR	SOIC	DW	16	2000	350.0	350.0	43.0
ISO7731BDWR	SOIC	DW	16	2000	367.0	367.0	38.0
ISO7731BDWR	SOIC	DW	16	2000	367.0	367.0	38.0
ISO7731DBQR	SSOP	DBQ	16	2500	350.0	350.0	43.0
ISO7731DWR	SOIC	DW	16	2000	350.0	350.0	43.0
ISO7731DWR	SOIC	DW	16	2000	356.0	356.0	35.0
ISO7731DWR	SOIC	DW	16	2000	356.0	356.0	35.0
ISO7731FBDWR	SOIC	DW	16	2000	350.0	350.0	43.0
ISO7731FBDWR	SOIC	DW	16	2000	367.0	367.0	38.0
ISO7731FBDWR	SOIC	DW	16	2000	367.0	367.0	38.0

Device	Package Type	Package Drawing	Pins	SPQ	Length (mm)	Width (mm)	Height (mm)
ISO7731FDBQR	SSOP	DBQ	16	2500	350.0	350.0	43.0
ISO7731FDWR	SOIC	DW	16	2000	350.0	350.0	43.0
ISO7731FDWR	SOIC	DW	16	2000	367.0	367.0	38.0
ISO7731FDWR	SOIC	DW	16	2000	367.0	367.0	38.0

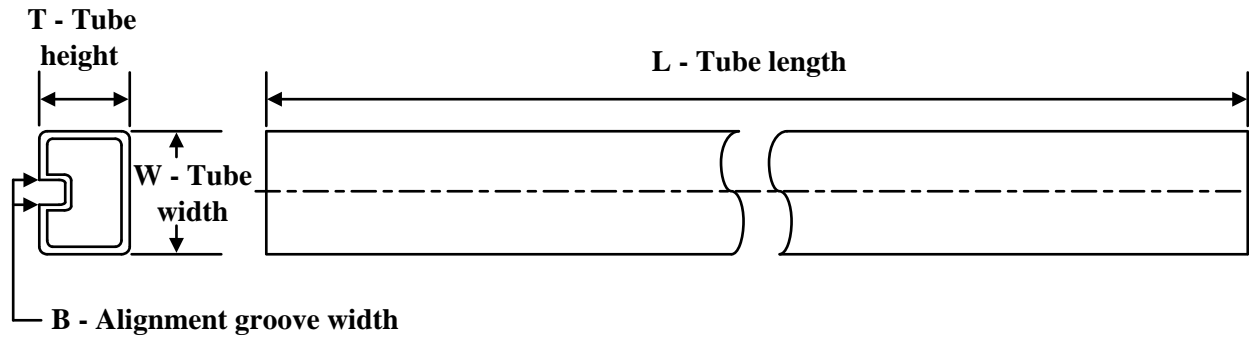
TUBE

*All dimensions are nominal

Device	Package Name	Package Type	Pins	SPQ	L (mm)	W (mm)	T (μm)	B (mm)
ISO7730DBQ	DBQ	SSOP	16	75	505.46	6.76	3810	4
ISO7730DW	DW	SOIC	16	40	507	12.83	5080	6.6
ISO7730DW	DW	SOIC	16	40	506.98	12.7	4826	6.6
ISO7730FDBQ	DBQ	SSOP	16	75	505.46	6.76	3810	4
ISO7730FDW	DW	SOIC	16	40	507	12.83	5080	6.6
ISO7730FDW	DW	SOIC	16	40	506.98	12.7	4826	6.6
ISO7731BDW	DW	SOIC	16	40	506.98	12.7	4826	6.6
ISO7731BDW	DW	SOIC	16	40	507	12.83	5080	6.6
ISO7731DBQ	DBQ	SSOP	16	75	505.46	6.76	3810	4
ISO7731DW	DW	SOIC	16	40	506.98	12.7	4826	6.6
ISO7731DW	DW	SOIC	16	40	507	12.83	5080	6.6
ISO7731FBDW	DW	SOIC	16	40	506.98	12.7	4826	6.6
ISO7731FBDW	DW	SOIC	16	40	507	12.83	5080	6.6
ISO7731FDBQ	DBQ	SSOP	16	75	505.46	6.76	3810	4
ISO7731FDW	DW	SOIC	16	40	507	12.83	5080	6.6
ISO7731FDW	DW	SOIC	16	40	506.98	12.7	4826	6.6

GENERIC PACKAGE VIEW

DW 16

SOIC - 2.65 mm max height

7.5 x 10.3, 1.27 mm pitch

SMALL OUTLINE INTEGRATED CIRCUIT

This image is a representation of the package family, actual package may vary.
Refer to the product data sheet for package details.

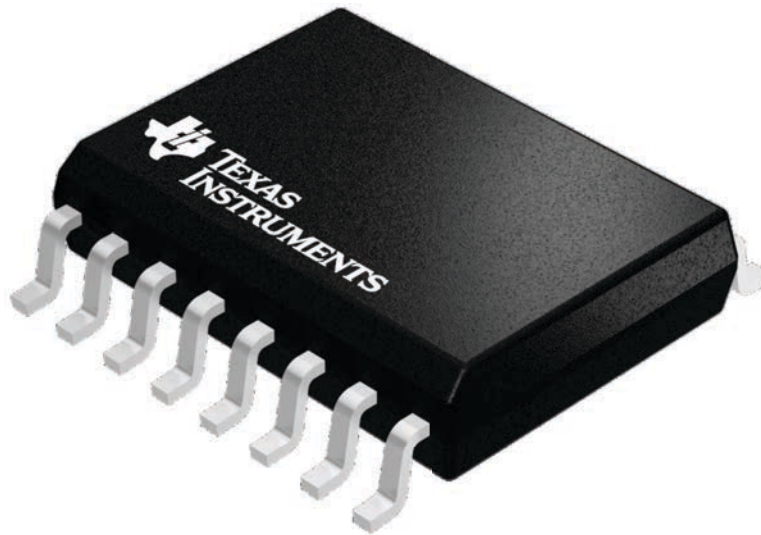

4224780/A

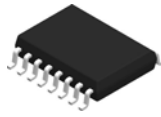

DW0016A

PACKAGE OUTLINE

SOIC - 2.65 mm max height

SOIC

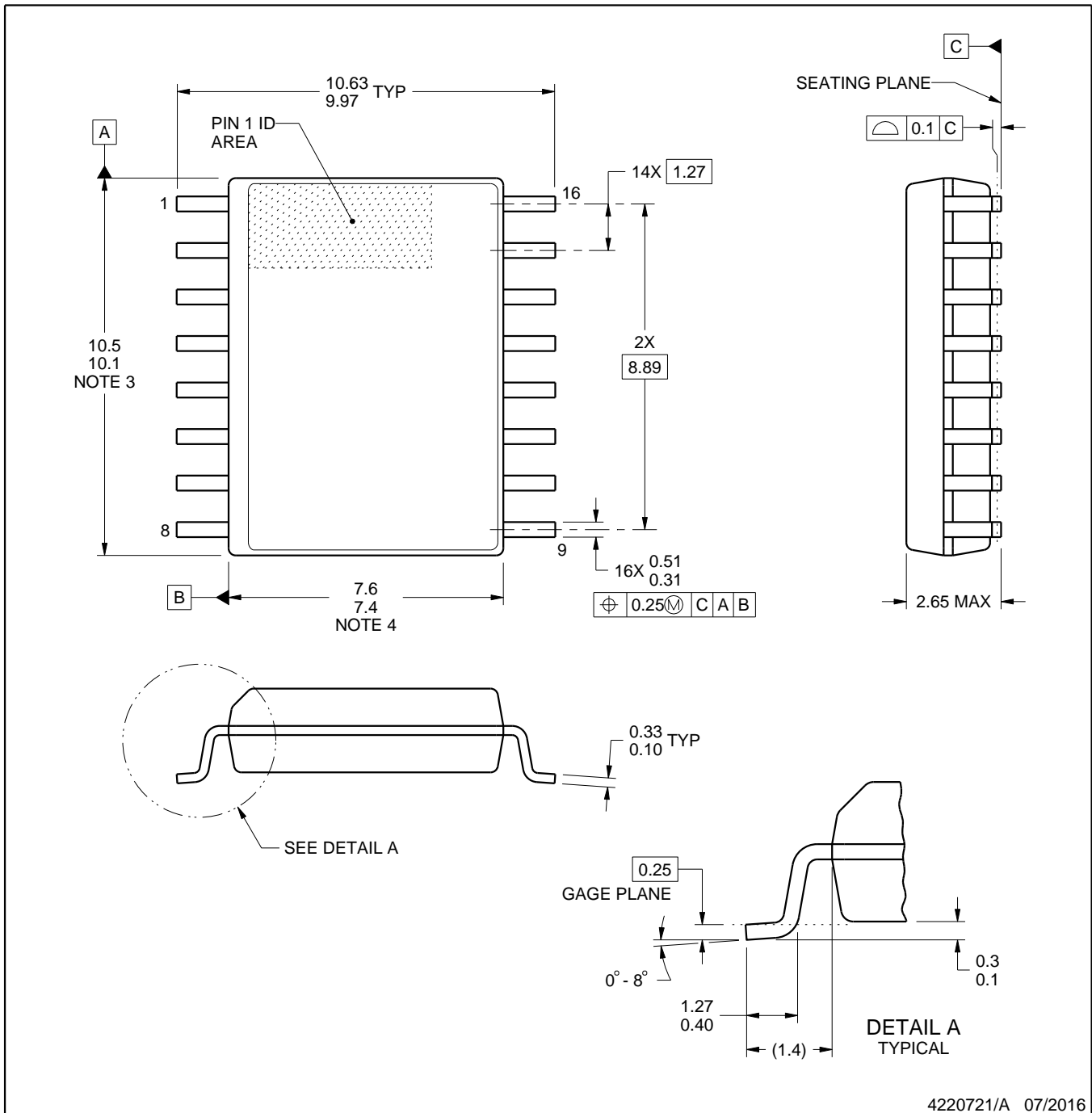

4220721/A 07/2016

NOTES:

1. All linear dimensions are in millimeters. Dimensions in parenthesis are for reference only. Dimensioning and tolerancing per ASME Y14.5M.
2. This drawing is subject to change without notice.
3. This dimension does not include mold flash, protrusions, or gate burrs. Mold flash, protrusions, or gate burrs shall not exceed 0.15 mm, per side.
4. This dimension does not include interlead flash. Interlead flash shall not exceed 0.25 mm, per side.
5. Reference JEDEC registration MS-013.

EXAMPLE BOARD LAYOUT

DW0016A

SOIC - 2.65 mm max height

SOIC

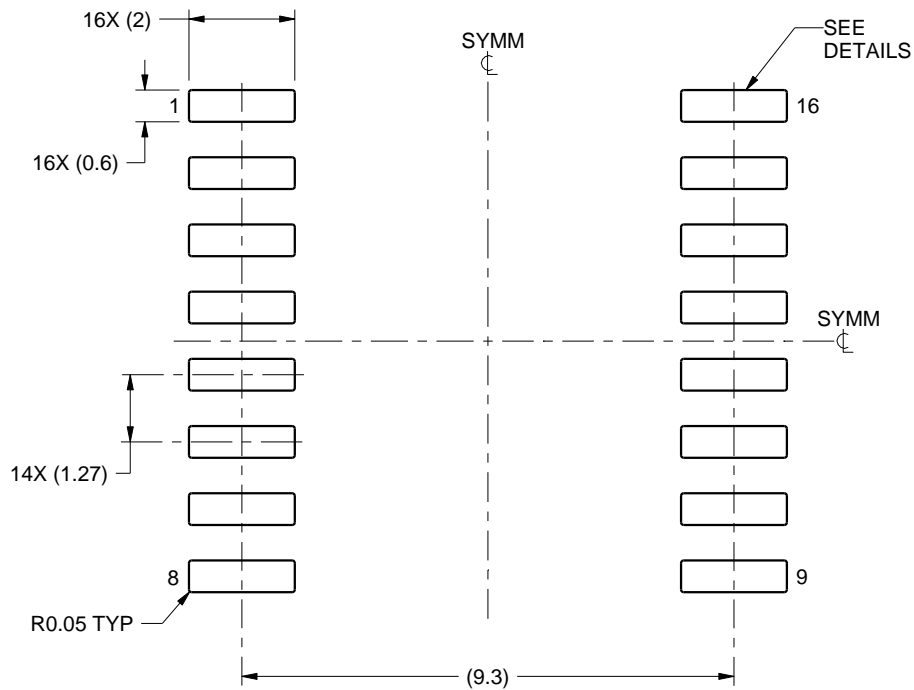

LAND PATTERN EXAMPLE
SCALE:7X

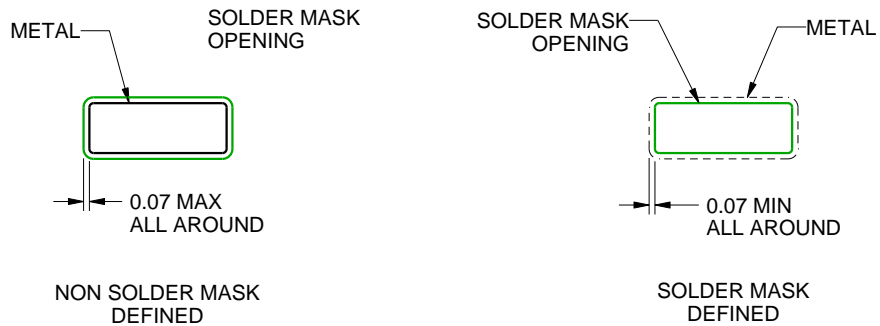

SOLDER MASK DETAILS

4220721/A 07/2016

NOTES: (continued)

6. Publication IPC-7351 may have alternate designs.

7. Solder mask tolerances between and around signal pads can vary based on board fabrication site.

EXAMPLE STENCIL DESIGN

DW0016A

SOIC - 2.65 mm max height

SOIC

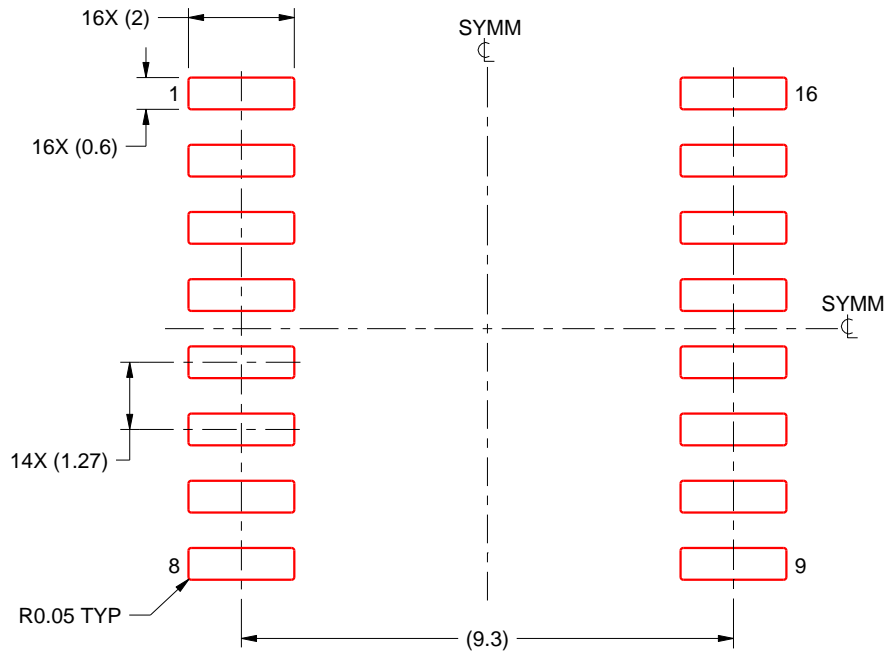

SOLDER PASTE EXAMPLE
BASED ON 0.125 mm THICK STENCIL
SCALE:7X

4220721/A 07/2016

NOTES: (continued)

8. Laser cutting apertures with trapezoidal walls and rounded corners may offer better paste release. IPC-7525 may have alternate design recommendations.
9. Board assembly site may have different recommendations for stencil design.

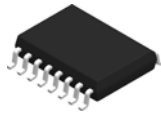

DW0016B

PACKAGE OUTLINE SOIC - 2.65 mm max height

SOIC

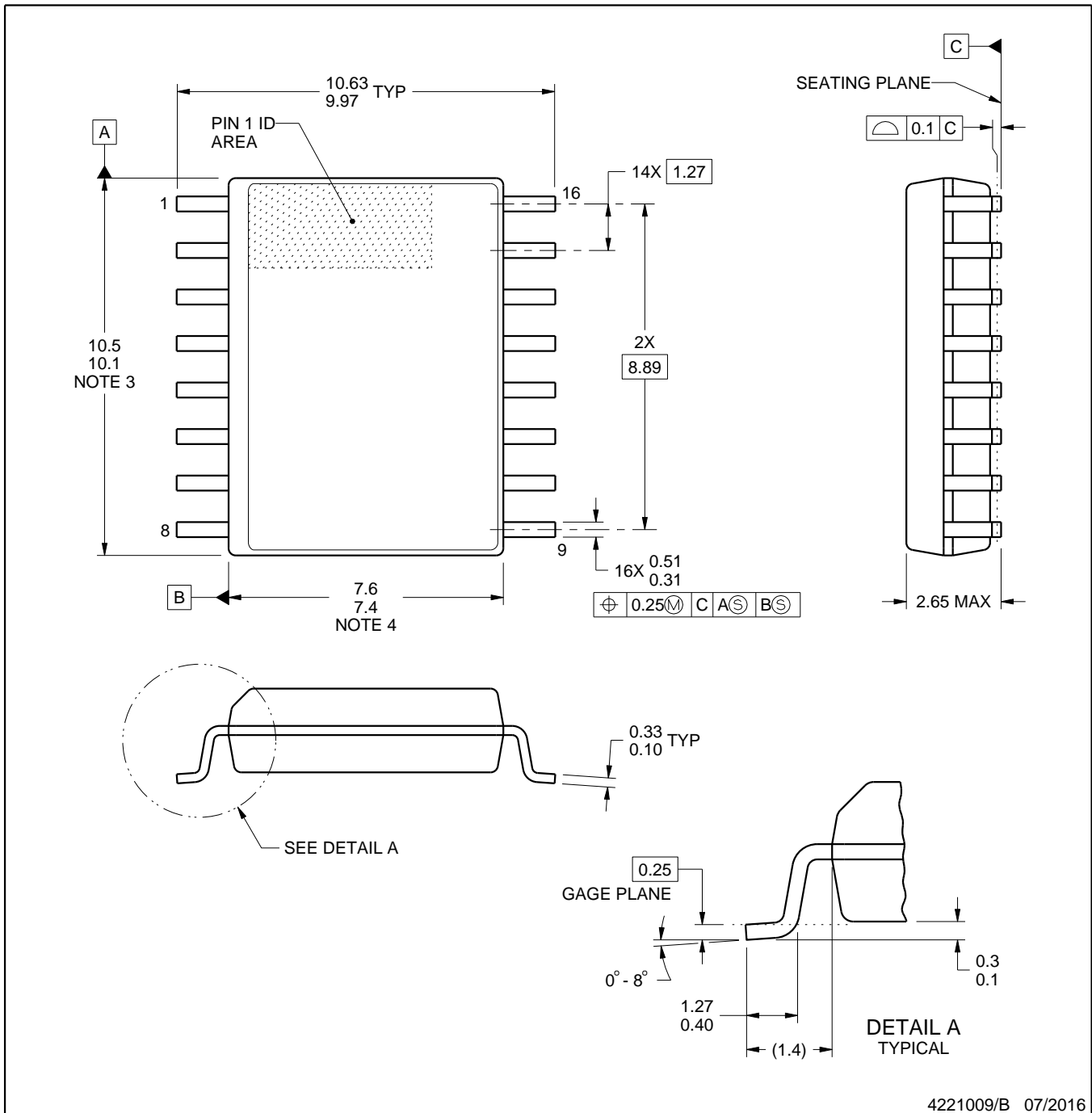

4221009/B 07/2016

NOTES:

1. All linear dimensions are in millimeters. Dimensions in parenthesis are for reference only. Dimensioning and tolerancing per ASME Y14.5M.
2. This drawing is subject to change without notice.
3. This dimension does not include mold flash, protrusions, or gate burrs. Mold flash, protrusions, or gate burrs shall not exceed 0.15 mm, per side.
4. This dimension does not include interlead flash. Interlead flash shall not exceed 0.25 mm, per side.
5. Reference JEDEC registration MS-013.

EXAMPLE BOARD LAYOUT

DW0016B

SOIC - 2.65 mm max height

SOIC

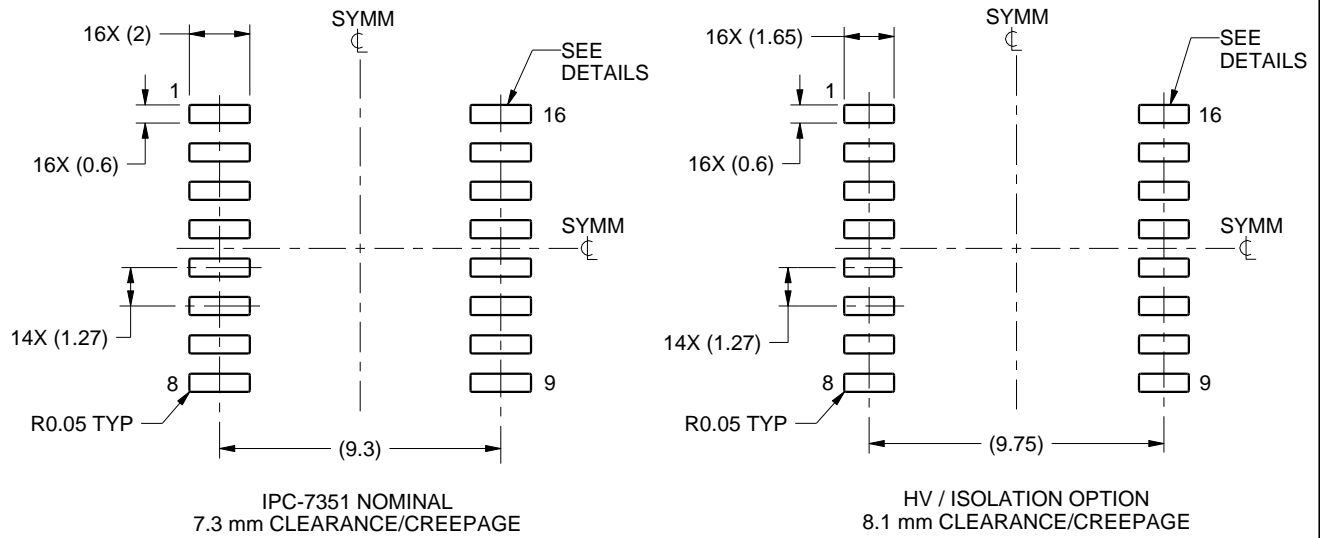

LAND PATTERN EXAMPLE
SCALE:4X

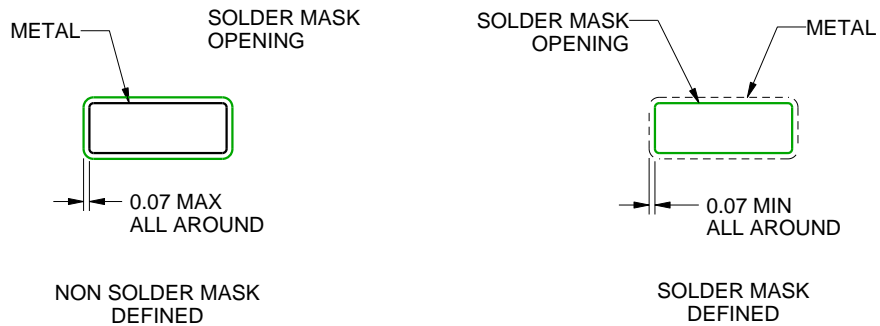

SOLDER MASK DETAILS

4221009/B 07/2016

NOTES: (continued)

- 6. Publication IPC-7351 may have alternate designs.
- 7. Solder mask tolerances between and around signal pads can vary based on board fabrication site.

EXAMPLE STENCIL DESIGN

DW0016B

SOIC - 2.65 mm max height

SOIC

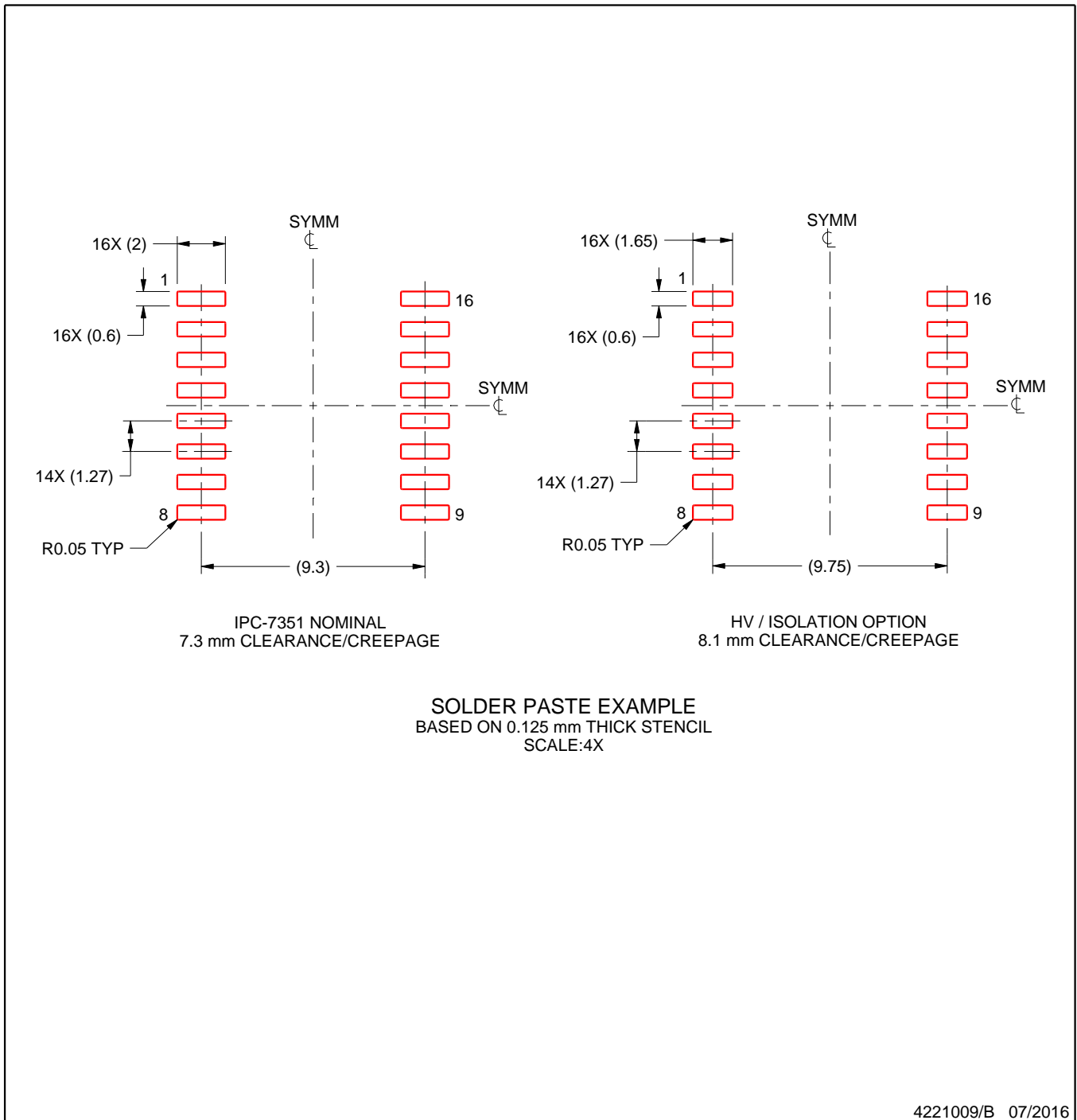

NOTES: (continued)

8. Laser cutting apertures with trapezoidal walls and rounded corners may offer better paste release. IPC-7525 may have alternate design recommendations.
9. Board assembly site may have different recommendations for stencil design.

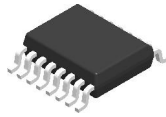

DBQ0016A

PACKAGE OUTLINE

SSOP - 1.75 mm max height

SHRINK SMALL-OUTLINE PACKAGE

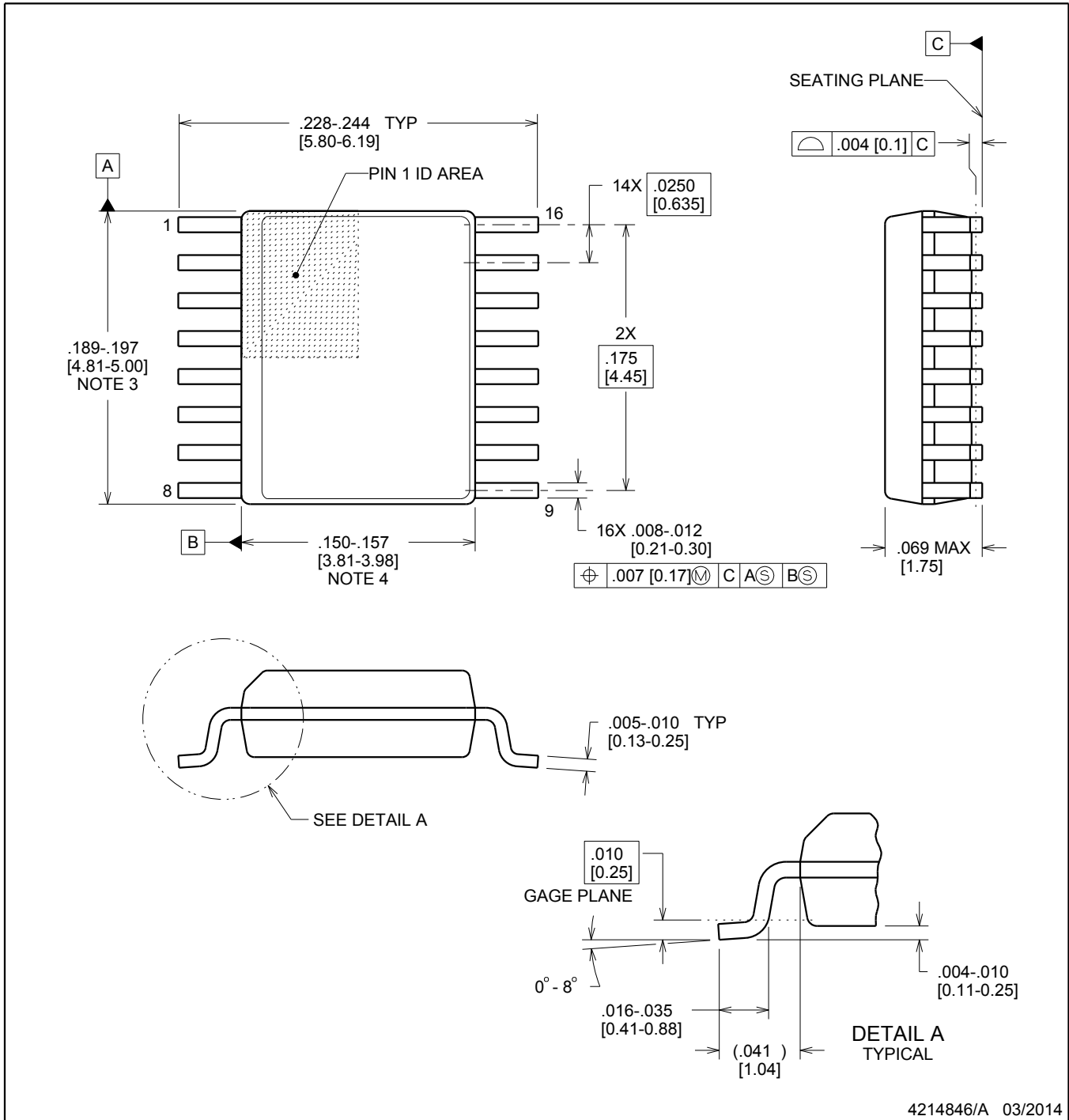

NOTES:

1. Linear dimensions are in inches [millimeters]. Dimensions in parenthesis are for reference only. Controlling dimensions are in inches. Dimensioning and tolerancing per ASME Y14.5M.
2. This drawing is subject to change without notice.
3. This dimension does not include mold flash, protrusions, or gate burrs. Mold flash, protrusions, or gate burrs shall not exceed .006 inch, per side.
4. This dimension does not include interlead flash.
5. Reference JEDEC registration MO-137, variation AB.

EXAMPLE BOARD LAYOUT

DBQ0016A

SSOP - 1.75 mm max height

SHRINK SMALL-OUTLINE PACKAGE

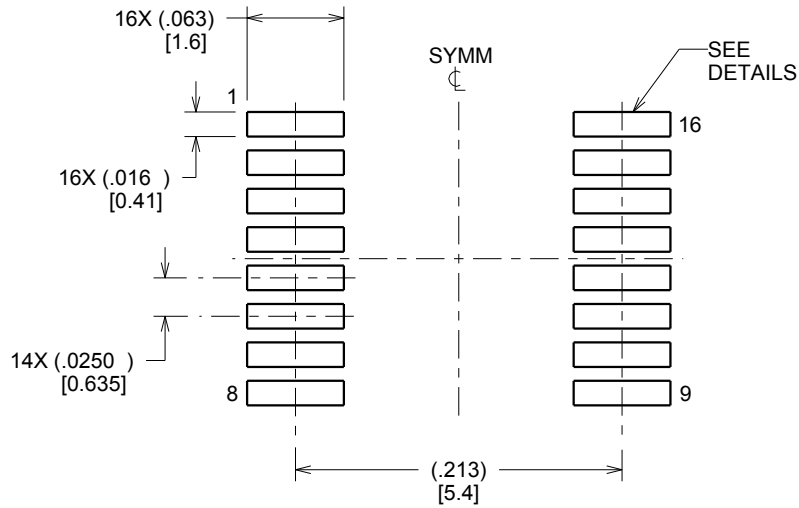

LAND PATTERN EXAMPLE
SCALE:8X

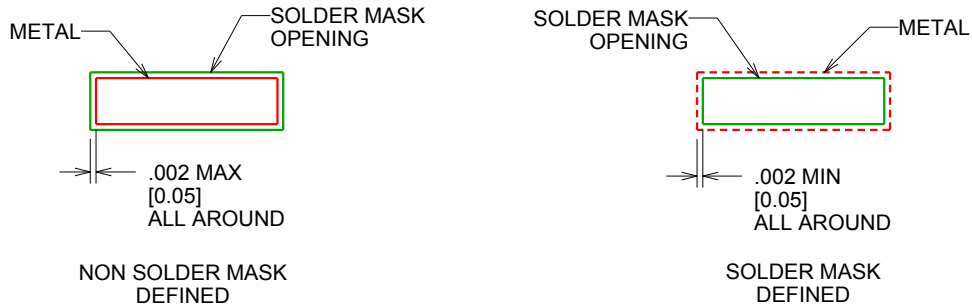

SOLDER MASK DETAILS

4214846/A 03/2014

NOTES: (continued)

6. Publication IPC-7351 may have alternate designs.

7. Solder mask tolerances between and around signal pads can vary based on board fabrication site.

EXAMPLE STENCIL DESIGN

DBQ0016A

SSOP - 1.75 mm max height

SHRINK SMALL-OUTLINE PACKAGE

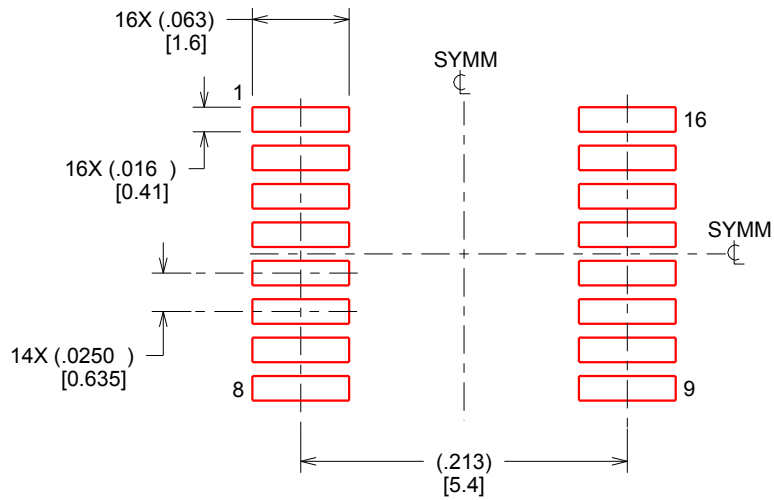

SOLDER PASTE EXAMPLE
BASED ON .005 INCH [0.127 MM] THICK STENCIL
SCALE:8X

4214846/A 03/2014

NOTES: (continued)

8. Laser cutting apertures with trapezoidal walls and rounded corners may offer better paste release. IPC-7525 may have alternate design recommendations.
9. Board assembly site may have different recommendations for stencil design.

重要声明和免责声明

TI“按原样”提供技术和可靠性数据（包括数据表）、设计资源（包括参考设计）、应用或其他设计建议、网络工具、安全信息和其他资源，不保证没有瑕疵且不做任何明示或暗示的担保，包括但不限于对适销性、某特定用途方面的适用性或不侵犯任何第三方知识产权的暗示担保。

这些资源可供使用 TI 产品进行设计的熟练开发人员使用。您将自行承担以下全部责任：(1) 针对您的应用选择合适的 TI 产品，(2) 设计、验证并测试您的应用，(3) 确保您的应用满足相应标准以及任何其他功能安全、信息安全、监管或其他要求。

这些资源如有变更，恕不另行通知。TI 授权您仅可将这些资源用于研发本资源所述的 TI 产品的应用。严禁对这些资源进行其他复制或展示。您无权使用任何其他 TI 知识产权或任何第三方知识产权。您应全额赔偿因在这些资源的使用中对 TI 及其代表造成的任何索赔、损害、成本、损失和债务，TI 对此概不负责。

TI 提供的产品受 [TI 的销售条款](#) 或 [ti.com](#) 上其他适用条款/TI 产品随附的其他适用条款的约束。TI 提供这些资源并不会扩展或以其他方式更改 TI 针对 TI 产品发布的适用的担保或担保免责声明。

TI 反对并拒绝您可能提出的任何其他或不同的条款。

邮寄地址：Texas Instruments, Post Office Box 655303, Dallas, Texas 75265

Copyright © 2022，德州仪器 (TI) 公司