

# ISOW7721 具有集成式低辐射、低噪声直流/直流转换器的双通道数字隔离器

## 1 特性

- 100 Mbps 数据速率
- 低辐射、低噪声的集成式直流/直流转换器
  - 辐射经过优化，符合 CISPR 32 和 EN 55032 B 类标准，在 2 层电路板上的裕度 >5dB
  - 25 MHz 的低频电源转换器可实现低噪声性能
  - 低输出波纹：24 mV
- 高效率输出功率
  - 最大负载时的效率：46%
  - 高达 0.55W 的输出功率
  - $V_{ISOOUT}$  精度为  $\pm 5\%$
  - 5V 至 5V：最大可用负载电流 = 110 mA
  - 5V 至 3.3V：最大可用负载电流 = 140 mA
  - 3.3V 至 3.3V：最大可用负载电流 = 60 mA
- 支持多 ISOW7721 链，可将系统功率输出提高至 >1W 和 >200mA
- 用于通道隔离器和电源转换器的独立电源
  - 逻辑电源 ( $V_{IO}$ )：1.71V 至 5.5V
  - 电源转换器电源 ( $V_{DD}$ )：3V 至 5.5V
- 优异的电磁兼容性 (EMC)
  - 系统级 ESD、EFT 和浪涌抗扰性
  - 在整个隔离栅具有  $\pm 8kV$  IEC 61000-4-2 接触放电保护
- 增强型和基础型隔离选项
- 高 CMTI：100kV/ $\mu s$  (典型值)
- 安全相关认证 (计划)：
  - 符合 DIN VDE V 0884-11:2017-01 标准的 VDE 增强型和基础型绝缘
  - UL 1577 组件认证计划
  - IEC 62368-1、IEC 61010-1、IEC 60601-1 和 GB 4943.1-2011 认证
- 工作温度范围：-40°C 至 +125°C
- 20 引脚宽体 SOIC 封装

## 2 应用

- 工厂自动化
- 电机控制
- 电网基础设施
- 医疗设备
- 测试和测量

## 3 说明

ISOW7721 器件是具有低辐射集成式高效电源转换器的电隔离双通道数字隔离器。集成式直流/直流转换器提供高达 550mW 的隔离式电源，无需在空间受限的隔离设计中单独使用隔离式电源。如果需要额外的电源，ISOW7721 支持多器件链，通过在系统中使用两个器件将集成电源输出增加至 >1W。

器件信息

特性	ISOW7721 ISOW7721F
保护级别	增强型
浪涌测试电压	10kV <sub>PK</sub>
隔离额定值	5000V <sub>RMS</sub>
工作电压	1000V <sub>RMS</sub> /1500V <sub>PK</sub>
封装	DFM (20)
封装尺寸 (标称值)	12.83 mm x 7.5 mm

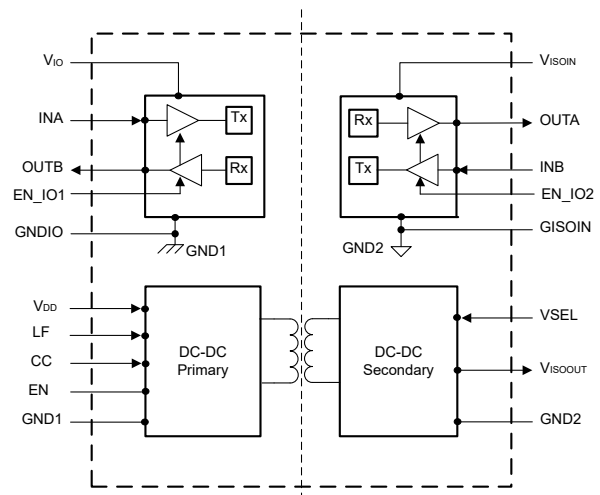

ISOW7721 简化原理图



## Table of Contents

<b>1 特性</b> .....	1	7.18 Supply Current Characteristics Channel Isolator - $V_{IO}$ , $V_{ISOIN} = 1.8\text{-V}$ .....	16
<b>2 应用</b> .....	1	7.19 Switching Characteristics - 5-V Supply.....	17
<b>3 说明</b> .....	1	7.20 Switching Characteristics - 3.3-V Supply.....	18
<b>4 Revision History</b> .....	2	7.21 Switching Characteristics - 2.5-V Supply.....	19
<b>5 说明 (续)</b> .....	3	7.22 Switching Characteristics - 1.8-V Supply.....	20
<b>6 Pin Configuration and Functions</b> .....	4	7.23 Insulation Characteristics Curves.....	21
<b>7 Specifications</b> .....	6	7.24 Typical Characteristics.....	22
7.1 Absolute Maximum Ratings.....	6	<b>8 Parameter Measurement Information</b> .....	27
7.2 ESD Ratings.....	6	<b>9 Detailed Description</b> .....	29
7.3 Recommended Operating Conditions.....	7	9.1 Overview.....	29
7.4 Thermal Information.....	8	9.2 Functional Block Diagram.....	30
7.5 Power Ratings.....	8	9.3 Feature Description.....	31
7.6 Insulation Specifications.....	9	9.4 Device Functional Modes.....	35
7.7 Safety-Related Certifications.....	10	<b>10 Application and Implementation</b> .....	37
7.8 Safety Limiting Values.....	10	10.1 Application Information.....	37
7.9 Electrical Characteristics - Power Converter.....	11	10.2 Typical Application.....	37
7.10 Supply Current Characteristics - Power Converter.....	12	<b>11 Power Supply Recommendations</b> .....	41
7.11 Electrical Characteristics Channel Isolator - $V_{IO}$ , $V_{ISOIN} = 5\text{-V}$ .....	13	<b>12 Layout</b> .....	42
7.12 Supply Current Characteristics Channel Isolator - $V_{IO}$ , $V_{ISOIN} = 5\text{-V}$ .....	13	12.1 Layout Guidelines.....	42
7.13 Electrical Characteristics Channel Isolator - $V_{IO}$ , $V_{ISOIN} = 3.3\text{-V}$ .....	14	12.2 Layout Example.....	43
7.14 Supply Current Characteristics Channel Isolator - $V_{IO}$ , $V_{ISOIN} = 3.3\text{-V}$ .....	14	<b>13 Device and Documentation Support</b> .....	44
7.15 Electrical Characteristics Channel Isolator - $V_{IO}$ , $V_{ISOIN} = 2.5\text{-V}$ .....	15	13.1 Device Support.....	44
7.16 Supply Current Characteristics Channel Isolator - $V_{IO}$ , $V_{ISOIN} = 2.5\text{-V}$ .....	15	13.2 Documentation Support.....	44
7.17 Electrical Characteristics Channel Isolator - $V_{IO}$ , $V_{ISOIN} = 1.8\text{-V}$ .....	16	13.3 Receiving Notification of Documentation Updates.....	44
		13.4 支持资源.....	44
		13.5 Trademarks.....	44
		13.6 Electrostatic Discharge Caution.....	44
		13.7 术语表.....	44
		<b>14 Mechanical, Packaging, and Orderable Information</b> .....	45

## 4 Revision History

注：以前版本的页码可能与当前版本的页码不同

DATE	REVISION	NOTES
July 2022	*	Initial release.

## 5 说明 (续)

电源转换器可在  $-40^{\circ}\text{C}$  至  $+125^{\circ}\text{C}$  的宽工作环境温度范围内高效运行。该器件提供改进的发射性能，简化了电路板设计，并提供了铁氧体磁珠以进一步衰减发射。**ISOW7721** 旨在提供增强的保护功能，包括限制浪涌电流的软启动、过压和欠压锁定、过载和短路保护以及热关断。

**ISOW7721** 在隔离 CMOS 或 LVCMOS 数字 I/O 时，可提供高电磁抗扰度。该信号隔离通道具有逻辑输入和输出缓冲器，由双电容二氧化硅 ( $\text{SiO}_2$ ) 绝缘栅隔开，而电源隔离使用片上变压器，采用薄膜聚合物作为绝缘材料进行隔离。**ISOW7721** 具有 1 个正向通道和 1 个反向通道。如果输入信号丢失，不具有 F 后缀的 **ISOW7721** 器件默认输出高电平，而具有 F 后缀的 **ISOW7721F** 器件默认输出低电平。**ISOW7721** 通过将  $V_{\text{IO}}$  和  $V_{\text{DD}}$  一起连接到 PCB 上，可在 3V 至 5.5V 的单一电源下运行。如果需要较低的逻辑电平，这些器件支持 1.71V 至 5.5V 逻辑电源 ( $V_{\text{IO}}$ )，该电源独立于 3V 至 5.5V 的电源转换器电源 ( $V_{\text{DD}}$ )。 $V_{\text{ISOIN}}$  和  $V_{\text{ISOOUT}}$  需要通过铁氧体磁珠或通过 LDO 馈电连接到电路板。

这些器件有助于防止数据总线 (例如，UART、RS-485、RS-232 和 CAN) 或者其他电路上的噪声电流进入本地接地以及干扰或损坏敏感电路。通过创新的芯片设计和布线技术，该器件的电磁兼容性得到了显著增强，可缓解系统级 ESD、EFT、浪涌和辐射合规性。器件采用 20 引脚 SOIC 宽体 (SOIC-WB) DFM 封装。

## 6 Pin Configuration and Functions



图 6-1. ISOW7721 DFM Package 20-Pin SOIC Top View

表 6-1. Pin Functions

NAME	PIN		I/O	DESCRIPTION
	NO.	ISOW7721		
EN_IO1	4		I	Output Enable 1: When EN_IO1 is high or open then the channel output pin on side 1 is enabled. When EN_IO1 is low then the channel output pin on side 1 is in a high impedance state and the transmitter of the channel input pin on side 1 is disabled.
EN_IO2	17		I	Output Enable 2: When EN_IO2 is high or open then the channel output pin on side 2 is enabled. When EN_IO2 is low then the channel output pin on side 2 is in a high impedance state and the transmitter of the channel input pin on side 2 is disabled.
GNDIO	6		—	Ground connection for $V_{IO}$ . GND1 and GNDIO need to be shorted on board.
GISOIN	15		—	Ground connection for $V_{ISOIN}$ . GND2 and GISOIN pins can be shorted on board or connected through a ferrite bead. See the <a href="#">Layout Section</a> for more information.
GND1	10		—	Ground connection for $V_{DD}$ . GND1 and GNDIO needs to be shorted on board.
GND2	11		—	Ground connection for $V_{ISOOUT}$ . GND2 and GISOIN pins can be shorted on board or connected through a ferrite bead. See the <a href="#">Layout Section</a> for more information.
INA	2		I	Input channel A
INB	18		I	Input channel B
CC	8		I/O	Multiple device primary/secondary synchronization pin. When LF is set to GND1, CC is an output used to sync to an additional ISOW7721. When LF is set to $V_{DD}$ , CC is an input. Connect the CC pin of the primary device to all the secondary devices. Leave CC floating if unused. See <a href="#">Multi-Device Chaining for Increased Power Output</a> for more information.
LF	7		I	Multiple device primary/secondary control logic. Connect the LF to GND1 when used as the primary device or to $V_{DD}$ if used as the secondary device. Tie LF to GND1 if used as a standalone device when not chaining the power converters. See <a href="#">Multi-Device Chaining for Increased Power Output</a> for more information.
OUTA	19		O	Output channel A
OUTB	3		O	Output channel B

**表 6-1. Pin Functions (continued)**

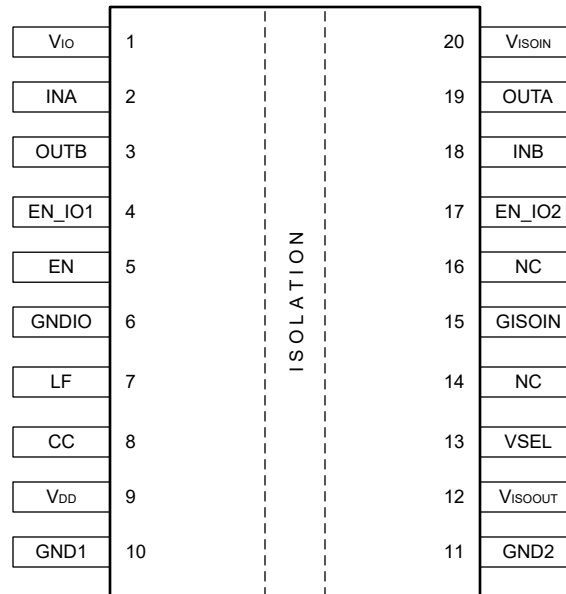
PIN		I/O	DESCRIPTION
NAME	NO. ISOW7721		
EN	5	I/O	Power converter enable input pin: enables and disables the integrated DC-DC power converter. Connect directly to microcontroller or through a series current limiting resistor to use as an enable input pin. DC-DC power converter is enabled when EN is high to the $V_{IO}$ voltage level and disabled when low at GND1 voltage level. See <a href="#">节 9.3.3</a> for more information
VSEL	13	I	$V_{ISOOUT}$ selection pin. $V_{ISOOUT} = 5\text{ V}$ when VSEL shorted to $V_{ISOOUT}$ . $V_{ISOOUT} = 3.3\text{ V}$ , when VSEL shorted to GND2. For more information see the <a href="#">Device Functional Modes</a> .
$V_{IO}$	1	—	Side 1 logic supply.
$V_{DD}$	9	—	Side 1 DC-DC converter power supply.
$V_{ISOIN}$	20	—	Side 2 supply voltage for isolation channels. $V_{ISOIN}$ and $V_{ISOOUT}$ pins can be shorted on board or connected through a ferrite bead. See <a href="#">Application and Implementation</a> for more information.
$V_{ISOOUT}$	12	—	Isolated power converter output voltage. $V_{ISOIN}$ and $V_{ISOOUT}$ pins can be shorted on board or connected through a ferrite bead. See <a href="#">Application and Implementation</a> for more information.

## 7 Specifications

### 7.1 Absolute Maximum Ratings

over operating free-air temperature range (unless otherwise noted)<sup>(1)</sup> <sup>(2)</sup>

		MIN	MAX	UNIT
V <sub>DD</sub>	Power converter supply voltage	- 0.5	6	V
V <sub>ISOIN</sub>	Isolated supply voltage, input supply for secondary side isolation channels	- 0.5	6	V
V <sub>ISOOUT</sub>	Isolated supply voltage, Power converter output V <sub>SEL</sub> shorted to GND2	- 0.5	4	V
V <sub>ISOOUT</sub>	Isolated supply voltage, Power converter output V <sub>SEL</sub> shorted to V <sub>ISOOUT</sub>	- 0.5	6	V
V <sub>IO</sub>	Primary side logic supply voltage	- 0.5	6	V
V <sub>LF</sub>	Voltage at LF	-0.5	6	V
V	Voltage at INx, OUTx, EN_IOx <sup>(3)</sup>	- 0.5	V <sub>SI</sub> + 0.5	V
	Voltage at EN/FLT	- 0.5	V <sub>SI</sub> + 0.5	V
	Voltage at VSEL	- 0.5	V <sub>ISOOUT</sub> + 0.5	V
I <sub>O</sub>	Maximum output current through data channels	- 15	15	mA
T <sub>J</sub>	Junction temperature	- 40	150	°C
T <sub>stg</sub>	Storage temperature	- 65	150	°C

- Stresses beyond those listed under *Absolute Maximum Rating* may cause permanent damage to the device. These are stress ratings only, which do not imply functional operation of the device at these or any other conditions beyond those indicated under *Recommended Operating Condition*. Exposure to absolute-maximum-rated conditions for extended periods may affect device reliability.
- V<sub>DD</sub>, V<sub>ISOIN</sub>, V<sub>ISOOUT</sub>, and V<sub>IO</sub> are with respect to the local ground pin (GND1 or GND2). All voltage values except differential I/O bus voltages are peak voltage values.
- V<sub>SI</sub> = input side supply; Cannot exceed 6 V.

### 7.2 ESD Ratings

			VALUE	UNIT
V <sub>(ESD)</sub>	Electrostatic discharge	Human-body model (HBM), per AEC Q100-002 <sup>(1)</sup> HBM ESD Classification Level 2	±3000	V
		Charged-device model (CDM), per AEC Q100-011 CDM ESD Classification Level C6	±1500	
		Contact discharge per IEC 61000-4-2 <sup>(2)</sup> Isolation barrier withstand test	±8000	

- AEC Q100-002 indicates that HBM stressing shall be in accordance with the ANSI/ESDA/JEDEC JS-001 specification.
- IEC ESD strike is applied across the barrier with all pins on each side tied together creating a two-terminal device.

### 7.3 Recommended Operating Conditions

Over recommended operating conditions, typical values are at  $V_{DD} = V_{IO} = 3.3\text{ V}$  and  $T_A = 25^\circ\text{C}$ ,  $GND1 = GNDIO$ ,  $GND2 = GISOIN$  (unless otherwise noted)

			MIN	NOM	MAX	UNIT
<b>Power Converter</b>						
$V_{DD}$	Power converter supply voltage	3.3 V operation	2.97	3.3	3.63	V
		5 V operation	4.5	5	5.5	V
$V_{DD(UVLO+)}$	Positive threshold when power converter supply is rising	Positive threshold when power converter supply is rising		2.7	2.95	V
$V_{DD(UVLO-)}$	Positive threshold when power converter supply is falling	Positive threshold when power converter supply is falling	2.40	2.55		V
$V_{DD(HYS)}$	Power converter supply voltage hysteresis	Power converter supply voltage hysteresis	0.15			V
<b>Channel Isolation</b>						
$V_{IO}, V_{ISOIN}$ <sup>(3)</sup>	Channel logic supply voltage	1.8 V operation	1.71		1.89	V
		2.5 V, 3.3 V, and 5 V operation	2.25		5.5	V
$V_{IO(UVLO+)}$	Rising threshold of logic supply voltage			1.55	1.7	V
$V_{IO(UVLO-)}$	Falling threshold of logic supply voltage		1.0	1.41		V
$V_{IO(HYS)}$	Logic supply voltage hysteresis		75			mV
$I_{OH}$	High level output current <sup>(1)</sup>	$V_{ISOIN} = 5\text{ V}$	-4			mA
		$V_{ISOIN} = 3.3\text{ V}$	-2			mA
		$V_{ISOIN} = 2.5\text{ V}$	-1			mA
		$V_{ISOIN} = 1.8\text{ V}$	-1			mA
$I_{OL}$	Low level output current <sup>(1)</sup>	$V_{ISOIN} = 5\text{ V}$			4	mA
		$V_{ISOIN} = 3.3\text{ V}$			2	mA
		$V_{ISOIN} = 2.5\text{ V}$			1	mA
		$V_{ISOIN} = 1.8\text{ V}$			1	mA
$V_{IH}$	High-level input voltage <sup>(2)</sup>		$0.7 \times V_{SI}$		$V_{SI}$	V
$V_{IL}$	Low-level input voltage		0		$0.3 \times V_{SI}$	V
DR	Data rate				100	Mbps
$t_{PWRUP}$	Channel isolator ready after power up or EN/FLT high	$V_{ISOIN} > V_{IO(UVLO+)}$		5		ms
$T_A$	Ambient temperature		-40		125	$^\circ\text{C}$

(1) This current is for data output channel.

(2)  $V_{SI}$  = input side supply;  $V_{SO}$  = output side supply

(3) The channel outputs are in undetermined state when  $1.89\text{ V} < V_{SI} < 2.25\text{ V}$  and  $1.05\text{ V} < V_{SI} < 1.71\text{ V}$

## 7.4 Thermal Information

THERMAL METRIC <sup>(1)</sup>		ISOW7721	UNIT
		DFM (SOIC)	
		20 PINS	
$R_{\theta JA}$	Junction-to-ambient thermal resistance	68.5	°C/W
$R_{\theta JC(top)}$	Junction-to-case (top) thermal resistance	24.6	°C/W
$R_{\theta JB}$	Junction-to-board thermal resistance	53.7	°C/W
$\Psi_{JT}$	Junction-to-top characterization parameter	17.1	°C/W
$\Psi_{JB}$	Junction-to-board characterization parameter	50.9	°C/W
$R_{\theta JC(bot)}$	Junction-to-case (bottom) thermal resistance	—	°C/W

(1) For more information about traditional and new thermal metrics, see the [Semiconductor and IC Package Thermal Metrics application report](#).

## 7.5 Power Ratings

$V_{DD} = V_{IO} = 5.5\text{ V}$ ,  $I_{ISO} = 110\text{ mA}$ ,  $T_J = 150^\circ\text{C}$ ,  $T_A \leq 80^\circ\text{C}$ ,  $C_L = 15\text{ pF}$ , input a 50-MHz 50% duty-cycle square wave

PARAMETER		TEST CONDITIONS	MIN	TYP	MAX	UNIT
$P_D$	Maximum power dissipation (both sides)	$V_{DD} = 5.5\text{ V}$ , $V_{IO} = 5.5\text{ V}$ , $V_{ISOOUT} = V_{ISOIN}$ , $I_{ISOOUT} = 100\text{ mA}$ , $T_J = 150^\circ\text{C}$ , $T_A \leq 80^\circ\text{C}$ , $C_L = 15\text{ pF}$ , input a 50-MHz 50% duty-cycle square wave			1.48	W
$P_{D1}$	Maximum power dissipation (side-1)				0.74	W
$P_{D2}$	Maximum power dissipation (side-2)				0.74	W

## 7.6 Insulation Specifications

PARAMETER		TEST CONDITIONS	VALUE	UNIT
<b>GENERAL</b>				
CLR	External clearance <sup>(1)</sup>	Shortest terminal-to-terminal distance through air	>8	mm
CPG	External creepage <sup>(1)</sup>	Shortest terminal-to-terminal distance across the package surface	>8	mm
DTI	Distance through the insulation	Minimum internal gap (internal clearance - capacitive signal isolation)	> 17	μm
		Minimum internal gap (internal clearance - transformer power isolation)	>120	
CTI	Comparative tracking index	DIN EN 60112 (VDE 0303-11); IEC 60112	> 600	V
	Material group	According to IEC 60664-1	I	
	Overvoltage category per IEC 60664-1	Rated mains voltage ≤ 300 V <sub>RMS</sub>	I-IV	
		Rated mains voltage ≤ 600 V <sub>RMS</sub>	I-IV	
		Rated mains voltage ≤ 1000 V <sub>RMS</sub>	I-III	
<b>DIN VDE V 0884-11:2017-01<sup>(2)</sup></b>				
V <sub>IORM</sub>	Maximum repetitive peak isolation voltage	AC voltage (bipolar)	1500	V <sub>PK</sub>
V <sub>IOWM</sub>	Maximum working isolation voltage	AC voltage; Time dependent dielectric breakdown (TDDB) Test	1000	V <sub>RMS</sub>
		DC voltage	1500	V <sub>DC</sub>
V <sub>IOTM</sub>	Maximum transient isolation voltage	V <sub>TEST</sub> = V <sub>IOTM</sub> ; t = 60 s (qualification); V <sub>TEST</sub> = 1.2 × V <sub>IOTM</sub> ; t = 1 s (100% production)	7071	V <sub>PK</sub>
V <sub>IOSM</sub>	Maximum surge isolation voltage ISOW7721 <sup>(3)</sup>	Test method per IEC 62368-1, 1.2/50 μs waveform, V <sub>TEST</sub> = 1.6 × V <sub>IOSM</sub> = 10000 V <sub>PK</sub> (qualification)	6250	V <sub>PK</sub>
q <sub>pd</sub>	Apparent charge <sup>(4)</sup>	Method a, after input/output safety test subgroup 2/3, V <sub>ini</sub> = V <sub>IOTM</sub> , t <sub>ini</sub> = 60 s, V <sub>pd(m)</sub> = 1.2 × V <sub>IORM</sub> , t <sub>m</sub> = 10 s	≤ 5	pC
		Method a, after environmental tests subgroup 1, V <sub>ini</sub> = V <sub>IOTM</sub> , t <sub>ini</sub> = 60 s, V <sub>pd(m)</sub> = 1.6 × V <sub>IORM</sub> , t <sub>m</sub> = 10 s	≤ 5	
		Method b1, at routine test (100% production) and preconditioning (type test), V <sub>ini</sub> = 1.2 × V <sub>IOTM</sub> , t <sub>ini</sub> = 1 s, V <sub>pd(m)</sub> = 1.875 × V <sub>IORM</sub> , t <sub>m</sub> = 1 s	≤ 5	
C <sub>IO</sub>	Barrier capacitance, input to output <sup>(5)</sup>	V <sub>IO</sub> = 0.4 × sin(2 π ft), f = 1 MHz	~3.5	pF
R <sub>IO</sub>	Insulation resistance <sup>(5)</sup>	V <sub>IO</sub> = 500 V, T <sub>A</sub> = 25°C	> 10 <sup>12</sup>	Ω
		V <sub>IO</sub> = 500 V, 100°C ≤ T <sub>A</sub> ≤ 125°C	> 10 <sup>11</sup>	
		V <sub>IO</sub> = 500 V, T <sub>S</sub> = 150°C	> 10 <sup>9</sup>	
	Pollution degree		2	
	Climatic category		40/125/21	
<b>UL 1577</b>				
V <sub>ISO(UL)</sub>	Withstand isolation voltage	V <sub>TEST</sub> = V <sub>ISO(UL)</sub> = 5000 V <sub>RMS</sub> , t = 60 s (qualification), V <sub>TEST</sub> = 1.2 × V <sub>ISO(UL)</sub> = 6000 V <sub>RMS</sub> , t = 1 s (100% production)	5000	V <sub>RMS</sub>

- (1) Creepage and clearance requirements should be applied according to the specific equipment isolation standards of an application. Care should be taken to maintain the creepage and clearance distance of a board design to ensure that the mounting pads of the isolator on the printed-circuit board do not reduce this distance. Creepage and clearance on a printed-circuit board become equal in certain cases. Techniques such as inserting grooves, ribs, or both on a printed circuit board are used to help increase these specifications.
- (2) ISOW77xx is suitable for *safe electrical insulation* and ISOW77xxB is suitable for *basic electrical insulation* only within the safety ratings.. Compliance with the safety ratings shall be ensured by means of suitable protective circuits.
- (3) Testing is carried out in air or oil to determine the intrinsic surge immunity of the isolation barrier.
- (4) Apparent charge is electrical discharge caused by a partial discharge (pd).
- (5) All pins on each side of the barrier tied together creating a two-terminal device.

## 7.7 Safety-Related Certifications

VDE	CSA	UL	CQC	TUV
Certified according to DIN VDE V 0884-11:2017-01	Certified according to IEC 62368-1, and IEC 60601-1	Recognized under UL 1577 Component Recognition Program	Certified according to GB 4943.1-2011	Certified according to EN 61010-1:2010/A1:2019 and EN 62368-1:2014
Reinforced insulation; Maximum transient isolation voltage, 7071 V <sub>PK</sub> ; Maximum repetitive peak isolation voltage, 1500 V <sub>PK</sub> ; Maximum surge isolation voltage, 6250 V <sub>PK</sub> .	CSA 62368-1-19 and IEC 62368-1:2018 Ed. 3 and EN 62368-1:2020. (pollution degree 2, material group I) 600 V <sub>RMS</sub> maximum working voltage; 2 MOPP (Means of Patient Protection) per CSA 60601-1:14 and IEC 60601-1 Ed. 3+A1, 250 V <sub>RMS</sub> maximum working voltage. Temperature rating is 90°C for reinforced insulation and 125°C for basic insulation; see certificate for details.	Single protection, 5000 V <sub>RMS</sub>	Reinforced Insulation, Altitude ≤ 5000 m, Tropical Climate, 700 V <sub>RMS</sub> maximum working voltage;	5000 V <sub>RMS</sub> Reinforced insulation per EN 61010-1:2010 up to working voltage of 600 V <sub>RMS</sub> ; 5000 V <sub>RMS</sub> Reinforced insulation per EN 62368-1:2014 up to working voltage of 600 V <sub>RMS</sub> .
Certificate #: Pending Basic: Pending	Master Contract#: Pending	File #: Pending	Certificate #: Pending	Client ID: Pending

## 7.8 Safety Limiting Values

Safety limiting intends to minimize potential damage to the isolation barrier upon failure of input or output circuitry.

PARAMETER		TEST CONDITIONS	MIN	TYP	MAX	UNIT
I <sub>S</sub>	Safety input, output, or supply current <sup>(1)</sup>	R <sub>θJA</sub> = 68.5°C/W, V <sub>I</sub> = 5.5 V, T <sub>J</sub> = 150°C, T <sub>A</sub> = 25°C			332	mA
		R <sub>θJA</sub> = 68.5°C/W, V <sub>I</sub> = 3.6 V, T <sub>J</sub> = 150°C, T <sub>A</sub> = 25°C			507	
P <sub>S</sub>	Safety input, output, or total power <sup>(1)</sup>	R <sub>θJA</sub> = 68.5°C/W, T <sub>J</sub> = 150°C, T <sub>A</sub> = 25°C			1825	mW
T <sub>S</sub>	Maximum safety temperature <sup>(1)</sup>				150	°C

- (1) The maximum safety temperature, T<sub>S</sub>, has the same value as the maximum junction temperature, T<sub>J</sub>, specified for the device. The I<sub>S</sub> and P<sub>S</sub> parameters represent the safety current and safety power respectively. The maximum limits of I<sub>S</sub> and P<sub>S</sub> should not be exceeded. These limits vary with the ambient temperature, T<sub>A</sub>.

The junction-to-air thermal resistance, R<sub>θJA</sub>, in the Thermal Information table is that of a device installed on a high-K test board for leaded surface-mount packages. Use the following equations to calculate the value for each parameter:

T<sub>J</sub> = T<sub>A</sub> + R<sub>θJA</sub> × P, where P is the power dissipated in the device.

T<sub>J(max)</sub> = T<sub>S</sub> = T<sub>A</sub> + R<sub>θJA</sub> × P<sub>S</sub>, where T<sub>J(max)</sub> is the maximum allowed junction temperature.

P<sub>S</sub> = I<sub>S</sub> × V<sub>I</sub>, where V<sub>I</sub> is the maximum input voltage.

## 7.9 Electrical Characteristics - Power Converter

$V_{DD} = 5\text{ V} \pm 10\%$  or  $3.3\text{ V} \pm 10\%$  and  $V_{ISOIN}$  power externally, GND1 = GNDIO, GND2 = GISOIN (over recommended operating conditions, unless otherwise specified)

PARAMETER		TEST CONDITIONS	MIN	TYP	MAX	UNIT
<b><math>V_{DD} = 5\text{ V}</math>, <math>V_{ISOOUT} = 5\text{ V}</math>, <math>V_{SEL} = V_{ISOOUT}</math></b>						
$V_{ISOOUT}$	Isolated supply voltage	External $I_{ISOOUT} = 0$ to 55 mA	4.75	5	5.25	V
$V_{ISOOUT}$	Isolated supply voltage	External $I_{ISOOUT} = 0$ to 110 mA	4.5	5	5.25	V
$V_{ISOOUT(LINE)}$	DC line regulation	$I_{ISOOUT} = 55\text{ mA}$ , $V_{DD} = 4.5\text{ V}$ to 5.5 V		2		mV/V
$V_{ISOOUT(LOAD)}$	DC load regulation	$I_{ISOOUT} = 0$ to 110 mA		1%		
EFF	Efficiency at maximum load current <sup>(1)</sup>	$I_{ISOOUT} = 110\text{ mA}$ , $C_{LOAD} = 0.01\text{ }\mu\text{F} \parallel 10\text{ }\mu\text{F}$ ; $V_1 = V_{DD}$ (ISOW772x); $V_1 = 0\text{ V}$ (ISOW772x with F suffix).		46%		
$V_{ISOOUT(RIP)}$	Output ripple on isolated supply (pk-pk)	20-MHz bandwidth, $C_{LOAD} = 0.01\text{ }\mu\text{F} \parallel 20\text{ }\mu\text{F}$ , $I_{ISOOUT} = 110\text{ mA}$		24		mV
$I_{ISOOUT\_SC}$	DC current from $V_{DD}$ supply under short circuit on $V_{ISOOUT}$	$V_{ISOOUT}$ shorted to GND2		250		mA
<b><math>V_{DD} = 5\text{ V}</math>, <math>V_{ISOOUT} = 3.3\text{ V}</math>, <math>V_{SEL} = \text{GND2}</math></b>						
$V_{ISOOUT}$	Isolated supply voltage	External $I_{ISOOUT} = 0$ to 70 mA	3.135	3.3	3.465	V
$V_{ISOOUT}$	Isolated supply voltage	External $I_{ISOOUT} = 0$ to 140 mA	3.135	3.3	3.465	V
$V_{ISOOUT(LINE)}$	DC line regulation	$I_{ISOOUT} = 70\text{ mA}$ , $V_{DD} = 4.5\text{ V}$ to 5.5 V		2		mV/V
$V_{ISOOUT(LOAD)}$	DC load regulation	$I_{ISOOUT} = 0$ to 140 mA		1%		
EFF	Efficiency at maximum load current <sup>(1)</sup>	$I_{ISOOUT} = 140\text{ mA}$ , $C_{LOAD} = 0.01\text{ }\mu\text{F} \parallel 10\text{ }\mu\text{F}$ ; $V_1 = V_{DD}$ (ISOW772x); $V_1 = 0\text{ V}$ (ISOW772x with F suffix).		36%		
$V_{ISOOUT(RIP)}$	Output ripple on isolated supply (pk-pk)	20-MHz bandwidth, $C_{LOAD} = 0.01\text{ }\mu\text{F} \parallel 20\text{ }\mu\text{F}$ , $I_{ISOOUT} = 110\text{ mA}$		30		mV
$I_{ISOOUT\_SC}$	DC current from $V_{DD}$ supply under short circuit on $V_{ISOOUT}$	$V_{ISOOUT}$ shorted to GND2		250		mA
<b><math>V_{DD} = 3.3\text{ V}</math>, <math>V_{ISOOUT} = 3.3\text{ V}</math>, <math>V_{SEL} = \text{GND2}</math></b>						
$V_{ISOOUT}$	Isolated supply voltage	External $I_{ISOOUT} = 0$ to 30 mA	3.135	3.3	3.465	V
$V_{ISOOUT}$	Isolated supply voltage	External $I_{ISOOUT} = 0$ to 60 mA	3.135	3.3	3.465	V
$V_{ISOOUT(LINE)}$	DC line regulation	$I_{ISOOUT} = 30\text{ mA}$ , $V_{DD} = 3.0\text{ V}$ to 3.6 V		2		mV/V
$V_{ISOOUT(LOAD)}$	DC load regulation	$I_{ISOOUT} = 0$ to 60 mA		1%		
EFF	Efficiency at maximum load current <sup>(1)</sup>	$I_{ISOOUT} = 60\text{ mA}$ , $C_{LOAD} = 0.01\text{ }\mu\text{F} \parallel 10\text{ }\mu\text{F}$ ; $V_1 = V_{DD}$ (ISOW772x); $V_1 = 0\text{ V}$ (ISOW772x with F suffix).		43%		
$V_{ISOOUT(RIP)}$	Output ripple on isolated supply (pk-pk)	20-MHz bandwidth, $C_{LOAD} = 0.01\text{ }\mu\text{F} \parallel 20\text{ }\mu\text{F}$ , $I_{ISOOUT} = 60\text{ mA}$		14		mV
$I_{ISOOUT\_SC}$	DC current from $V_{DD}$ supply under short circuit on $V_{ISOOUT}$	$V_{ISOOUT}$ shorted to GND2		185		mA

- (1) Power converter  $I_{LOAD}$  = current required to power the secondary side.  $I_{LOAD}$  does not take into account the channel isolator current. See Supply Current Characteristics Channel Isolator section for details.

## 7.10 Supply Current Characteristics - Power Converter

$V_{DD} = 5\text{ V} \pm 10\%$  or  $3.3\text{ V} \pm 10\%$  GND1 = GNDIO, GND2 = GISOIN (over recommended operating conditions unless otherwise noted).

PARAMETER	TEST CONDITIONS		SUPPLY CURRENT	MIN	TYP	MAX	UNIT
<b>Power Converter Disabled</b>							
Power converter supply current	EN/FLT = GND1, $V_{ISOOUT} = \text{No } I_{LOAD}$		$I_{DD}$		0.28	0.45	mA
Logic supply current	EN/FLT = GND1		$I_{IO}$		0.27	0.57	mA
<b>Power Converter Enabled</b>							
Power converter supply current input	$V_{DD} = 5\text{ V}$ , $V_{SEL} = V_{ISOOUT}$	$I_{LOAD} = 55\text{ mA}$	$I_{DD}$		115	171	mA
	$V_{DD} = 5\text{ V}$ , $V_{SEL} = V_{ISOOUT}$	$I_{LOAD} = 110\text{ mA}$			225	316	mA
	$V_{DD} = 5\text{ V}$ , $V_{SEL} = \text{GND2}$	$I_{LOAD} = 70\text{ mA}$			127	169	mA
	$V_{DD} = 5\text{ V}$ , $V_{SEL} = \text{GND2}$	$I_{LOAD} = 140\text{ mA}$			250	310	mA
	$V_{DD} = 3.3\text{ V}$ , $V_{SEL} = \text{GND2}$	$I_{LOAD} = 30\text{ mA}$			74	112	mA
	$V_{DD} = 3.3\text{ V}$ , $V_{SEL} = \text{GND2}$	$I_{LOAD} = 60\text{ mA}$			143	216	mA
Power converter output current <sup>(1)</sup>	$V_{DD} = 5\text{ V}$	$V_{SEL} = V_{ISOOUT}$	$I_{ISOOUT}$		110		mA
	$V_{DD} = 5\text{ V}$	$V_{SEL} = \text{GND2}$			140		mA
	$V_{DD} = 3.3\text{ V}$	$V_{SEL} = \text{GND2}$			60		mA

(1)  $I_{LOAD}$  does not take into account the channel isolator current. See Supply Current Characteristics Channel Isolator section for details.

### 7.11 Electrical Characteristics Channel Isolator - $V_{IO}$ , $V_{ISOIN} = 5\text{-V}$

$V_{IO}$ ,  $V_{ISOIN} = 5\text{ V} \pm 10\%$  GND1 = GNDIO, GND2 = GISOIN (over recommended operating conditions, unless otherwise specified)

PARAMETER		TEST CONDITIONS	MIN	TYP	MAX	UNIT
<b>Channel Isolation</b>						
$V_{ITH}$	Input pin rising threshold				$0.7 \times V_{SI}$	V
$V_{ITL}$	Input pin falling threshold		$0.3 \times V_{SI}$			V
$V_{I(HYS)}$	Input pin threshold hysteresis (INx)		$0.1 \times V_{SI}$			V
$I_{IL}$	Low level input current	$V_{IL} = 0$ at INx	-25			$\mu\text{A}$
$I_{IH}$	High level input current	$V_{IH} = V_{SI}^{(1)}$ at INx			25	$\mu\text{A}$
$V_{OH}$	High level output voltage	$I_O = -4\text{ mA}$ , see <a href="#">Switching Characteristics Test Circuit and Voltage Waveforms</a>	$V_{SO}^{(1)} - 0.4$			V
$V_{OL}$	Low level output voltage	$I_O = 4\text{ mA}$ , see <a href="#">Switching Characteristics Test Circuit and Voltage Waveforms</a>			0.4	V
CMTI	Common mode transient immunity	$V_I = V_{SI}$ or $0\text{ V}$ , $V_{CM} = 1000\text{ V}$ ; see <a href="#">Common-Mode Transient Immunity Test Circuit</a>	85	100		kV/us

(1)  $V_{SI}$  = input side supply;  $V_{SO}$  = output side supply

### 7.12 Supply Current Characteristics Channel Isolator - $V_{IO}$ , $V_{ISOIN} = 5\text{-V}$

$V_{IO}$ ,  $V_{ISOIN} = 5\text{ V} \pm 10\%$  GND1 = GNDIO, GND2 = GISOIN (over recommended operating conditions, unless otherwise specified)

PARAMETER	TEST CONDITIONS	SUPPLY CURRENT	MIN	TYP	MAX	UNIT	
<b>ISOW7721 Channel Supply Current</b>							
Supply current - Disable	$EN_{IO1} = EN_{IO2} = 0\text{ V}$ ; $V_I = V_{CCI}^{(1)}$ (ISOW7721); $V_I = 0\text{ V}$ (ISOW7721 with F suffix)	$I_{DD\_IO}$		3.5	6	mA	
		$I_{ISOIN}$		3.5	5	mA	
		$I_{DD\_IO}$		3.5	6	mA	
		$I_{ISOIN}$		3.5	5	mA	
Channel Supply current - DC signal	$EN_{IO1} = EN_{IO2} = V_{CCI}$ ; $V_I = V_{CCI}$ (ISOW7721); $V_I = 0\text{ V}$ (ISOW7721 with F suffix)	$I_{DD\_IO}$		3.5	6	mA	
		$I_{ISOIN}$		3.5	5	mA	
		$I_{DD\_IO}$		4.5	7	mA	
		$I_{ISOIN}$		5	7	mA	
Channel Supply current - AC signal	All channels switching with square wave clock input; $C_L = 15\text{ pF}$	1 Mbps	$I_{DD\_IO}$		4	6.5	mA
			$I_{ISOIN}$		4	6	mA
		10 Mbps	$I_{DD\_IO}$		4.8	7	mA
			$I_{ISOIN}$		4.9	6.7	mA
		100 Mbps	$I_{DD\_IO}$		11.6	14.6	mA
			$I_{ISOIN}$		11.8	14.3	mA

(1)  $V_{CCI} = V_{IO}$  or  $V_{ISOIN}$

### 7.13 Electrical Characteristics Channel Isolator - $V_{IO}$ , $V_{ISOIN} = 3.3\text{-V}$

$V_{IO}$ ,  $V_{ISOIN} = 3.3\text{ V} \pm 10\%$  GND1 = GNDIO, GND2 = GISOIN (over recommended operating conditions, unless otherwise specified)

PARAMETER		TEST CONDITIONS	MIN	TYP	MAX	UNIT
<b>Channel Isolation</b>						
$V_{ITH}$	Input pin rising threshold			$0.7 \times V_{SI}$		V
$V_{ITL}$	Input pin falling threshold		$0.3 \times V_{SI}$			V
$V_{I(HYS)}$	Input pin threshold hysteresis (INx)		$0.1 \times V_{SI}$			V
$I_{IL}$	Low level input current	$V_{IL} = 0$ at INx	-25			$\mu\text{A}$
$I_{IH}$	High level input current	$V_{IH} = V_{SI}^{(1)}$ at INx			25	$\mu\text{A}$
$V_{OH}$	High level output voltage	$I_O = -4\text{ mA}$ , see <a href="#">Switching Characteristics Test Circuit and Voltage Waveforms</a>	$V_{SO}^{(1)} - 0.3$			V
$V_{OL}$	Low level output voltage	$I_O = 4\text{ mA}$ , see <a href="#">Switching Characteristics Test Circuit and Voltage Waveforms</a>			0.3	V
CMTI	Common mode transient immunity	$V_I = V_{SI}$ or $0\text{ V}$ , $V_{CM} = 1000\text{ V}$ ; see <a href="#">Common-Mode Transient Immunity Test Circuit</a>	85	100		kV/us

(1)  $V_{SI}$  = input side supply;  $V_{SO}$  = output side supply

### 7.14 Supply Current Characteristics Channel Isolator - $V_{IO}$ , $V_{ISOIN} = 3.3\text{-V}$

$V_{IO}$ ,  $V_{ISOIN} = 3.3\text{ V} \pm 10\%$  GND1 = GNDIO, GND2 = GISOIN (over recommended operating conditions, unless otherwise specified)

PARAMETER	TEST CONDITIONS	SUPPLY CURRENT	MIN	TYP	MAX	UNIT	
<b>ISOW7721 Channel Supply Current</b>							
Supply current - Disable	$EN_{IO1} = EN_{IO2} = 0\text{ V}$ ; $V_I = V_{CCI}^{(1)}$ (ISOW7721); $V_I = 0\text{ V}$ (ISOW7721 with F suffix)	$I_{DD\_IO}$		3.5	6	mA	
		$I_{ISOIN}$		3.5	5	mA	
		$I_{DD\_IO}$		3.5	6	mA	
		$I_{ISOIN}$		3.5	5	mA	
Channel Supply current - DC signal	$EN_{IO1} = EN_{IO2} = V_{CCI}$ ; $V_I = V_{CCI}$ (ISOW7721); $V_I = 0\text{ V}$ (ISOW7721 with F suffix)	$I_{DD\_IO}$		3.5	6	mA	
		$I_{ISOIN}$		3.5	5	mA	
		$I_{DD\_IO}$		4.5	7	mA	
		$I_{ISOIN}$		5	7	mA	
Channel Supply current - AC signal	All channels switching with square wave clock input; $C_L = 15\text{ pF}$	1 Mbps	$I_{DD\_IO}$		4	6.5	mA
			$I_{ISOIN}$		4	6	mA
		10 Mbps	$I_{DD\_IO}$		4.4	6.7	mA
			$I_{ISOIN}$		4.6	6.4	mA
		100 Mbps	$I_{DD\_IO}$		8.6	11.7	mA
			$I_{ISOIN}$		8.7	11.4	mA

(1)  $V_{CCI} = V_{IO}$  or  $V_{ISOIN}$

### 7.15 Electrical Characteristics Channel Isolator - $V_{IO}$ , $V_{ISOIN} = 2.5\text{-V}$

$V_{IO}$ ,  $V_{ISOIN} = 2.5\text{ V} \pm 10\%$  GND1 = GNDIO, GND2 = GISOIN (over recommended operating conditions, unless otherwise specified)

PARAMETER		TEST CONDITIONS	MIN	TYP	MAX	UNIT
<b>Channel Isolation</b>						
$V_{ITH}$	Input pin rising threshold				$0.7 \times V_{SI}$	V
$V_{ITL}$	Input pin falling threshold		$0.3 \times V_{SI}$			V
$V_{I(HYS)}$	Input pin threshold hysteresis (INx)		$0.1 \times V_{SI}$			V
$I_{IL}$	Low level input current	$V_{IL} = 0$ at INx	-25			$\mu\text{A}$
$I_{IH}$	High level input current	$V_{IH} = V_{SI}^{(1)}$ at INx			25	$\mu\text{A}$
$V_{OH}$	High level output voltage	$I_O = -4\text{ mA}$ , see <a href="#">Switching Characteristics Test Circuit and Voltage Waveforms</a>	$V_{SO}^{(1)} - 0.1$			V
$V_{OL}$	Low level output voltage	$I_O = 4\text{ mA}$ , see <a href="#">Switching Characteristics Test Circuit and Voltage Waveforms</a>			0.1	V
CMTI	Common mode transient immunity	$V_I = V_{SI}$ or $0\text{ V}$ , $V_{CM} = 1000\text{ V}$ ; see <a href="#">Common-Mode Transient Immunity Test Circuit</a>	85	100		kV/us

(1)  $V_{SI}$  = input side supply;  $V_{SO}$  = output side supply

### 7.16 Supply Current Characteristics Channel Isolator - $V_{IO}$ , $V_{ISOIN} = 2.5\text{-V}$

$V_{IO}$ ,  $V_{ISOIN} = 2.5\text{ V} \pm 10\%$  GND1 = GNDIO, GND2 = GISOIN (over recommended operating conditions, unless otherwise specified)

PARAMETER	TEST CONDITIONS	SUPPLY CURRENT	MIN	TYP	MAX	UNIT	
<b>ISOW7721 Channel Supply Current</b>							
Supply current - Disable	$EN_{IO1} = EN_{IO2} = 0\text{ V}$ ; $V_I = V_{CCI}^{(1)}$ (ISOW7721); $V_I = 0\text{ V}$ (ISOW7721 with F suffix)	$I_{DD\_IO}$		3.5	6	mA	
		$I_{ISOIN}$		3.5	5	mA	
		$I_{DD\_IO}$		3.5	6	mA	
		$I_{ISOIN}$		3.5	5	mA	
Channel Supply current - DC signal	$EN_{IO1} = EN_{IO2} = V_{CCI}$ ; $V_I = V_{CCI}$ (ISOW7721); $V_I = 0\text{ V}$ (ISOW7721 with F suffix)	$I_{DD\_IO}$		3.5	6	mA	
		$I_{ISOIN}$		3.5	5	mA	
		$I_{DD\_IO}$		4.5	7	mA	
		$I_{ISOIN}$		5	7	mA	
Channel Supply current - AC signal	All channels switching with square wave clock input; $C_L = 15\text{ pF}$	1 Mbps	$I_{DD\_IO}$		4	6	mA
			$I_{ISOIN}$		4	6	mA
		10 Mbps	$I_{DD\_IO}$		4.3	6.5	mA
			$I_{ISOIN}$		4.4	6.1	mA
		100 Mbps	$I_{DD\_IO}$		7.2	10	mA
			$I_{ISOIN}$		7.4	9.7	mA

(1)  $V_{CCI} = V_{IO}$  or  $V_{ISOIN}$

### 7.17 Electrical Characteristics Channel Isolator - $V_{IO}$ , $V_{ISOIN} = 1.8\text{-V}$

$V_{IO}$ ,  $V_{ISOIN} = 1.8\text{ V} \pm 5\%$  GND1 = GNDIO, GND2 = GISOIN (over recommended operating conditions, unless otherwise specified)

PARAMETER		TEST CONDITIONS	MIN	TYP	MAX	UNIT
<b>Channel Isolation</b>						
$V_{ITH}$	Input pin rising threshold			$0.7 \times V_{SI}$		V
$V_{ITL}$	Input pin falling threshold		$0.3 \times V_{SI}$			V
$V_{I(HYS)}$	Input pin threshold hysteresis (INx)		$0.1 \times V_{SI}$			V
$I_{IL}$	Low level input current	$V_{IL} = 0$ at INx	-25			$\mu\text{A}$
$I_{IH}$	High level input current	$V_{IH} = V_{SI}^{(1)}$ at INx			25	$\mu\text{A}$
$V_{OH}$	High level output voltage	$I_O = -4\text{ mA}$ , see <a href="#">Switching Characteristics Test Circuit and Voltage Waveforms</a>	$V_{SO}^{(1)} - 0.1$			V
$V_{OL}$	Low level output voltage	$I_O = 4\text{ mA}$ , see <a href="#">Switching Characteristics Test Circuit and Voltage Waveforms</a>			0.1	V
CMTI	Common mode transient immunity	$V_I = V_{SI}$ or $0\text{ V}$ , $V_{CM} = 1000\text{ V}$ ; see <a href="#">Common-Mode Transient Immunity Test Circuit</a>	85	100		kV/us

(1)  $V_{SI}$  = input side supply;  $V_{SO}$  = output side supply

### 7.18 Supply Current Characteristics Channel Isolator - $V_{IO}$ , $V_{ISOIN} = 1.8\text{-V}$

$V_{IO}$ ,  $V_{ISOIN} = 1.8\text{ V} \pm 5\%$  GND1 = GNDIO, GND2 = GISOIN (over recommended operating conditions, unless otherwise specified)

PARAMETER	TEST CONDITIONS	SUPPLY CURRENT	MIN	TYP	MAX	UNIT	
<b>ISOW7721 Channel Supply Current</b>							
Supply current - Disable	$EN_{IO1} = EN_{IO2} = 0\text{ V}$ ; $V_I = V_{CCI}^{(1)}$ (ISOW7721); $V_I = 0\text{ V}$ (ISOW7721 with F suffix)	$I_{DD\_IO}$		3.5	6	mA	
		$I_{ISOIN}$		3.5	5	mA	
	$EN_{IO1} = EN_{IO2} = 0\text{ V}$ ; $V_I = 0\text{ V}$ (ISOW7721); $V_I = V_{CCI}$ (ISOW7721 with F suffix)	$I_{DD\_IO}$		3.5	6	mA	
		$I_{ISOIN}$		3.5	5	mA	
Channel Supply current - DC signal	$EN_{IO1} = EN_{IO2} = V_{CCI}$ ; $V_I = V_{CCI}$ (ISOW7721); $V_I = 0\text{ V}$ (ISOW7721 with F suffix)	$I_{DD\_IO}$		3.5	6	mA	
		$I_{ISOIN}$		3.5	5	mA	
	$EN_{IO1} = EN_{IO2} = V_{CCI}$ ; $V_I = 0\text{ V}$ (ISOW7721); $V_I = V_{CCI}$ (ISOW7721 with F suffix)	$I_{DD\_IO}$		4.5	7	mA	
		$I_{ISOIN}$		5	6	mA	
Channel Supply current - AC signal	All channels switching with square wave clock input; $C_L = 15\text{ pF}$	1 Mbps	$I_{DD\_IO}$		4	6	mA
			$I_{ISOIN}$		3.5	5	mA
		10 Mbps	$I_{DD\_IO}$		4.3	6.5	mA
			$I_{ISOIN}$		4.4	6.1	mA
		100 Mbps	$I_{DD\_IO}$		6.7	9.1	mA
			$I_{ISOIN}$		6.9	8.8	mA

(1)  $V_{CCI} = V_{IO}$  or  $V_{ISOIN}$

## 7.19 Switching Characteristics - 5-V Supply

$V_{ISOIN} = 5\text{ V} \pm 10\%$ ,  $V_{IO} = 5\text{ V} \pm 10\%$ , GND1 = GNDIO, GND2 = GISOIN (over recommended operating conditions unless otherwise noted)

PARAMETER		TEST CONDITIONS	MIN	TYP	MAX	UNIT
$t_{PLH}$ , $t_{PHL}$	Propagation delay time	See <a href="#">Switching Characteristics Test Circuit and Voltage Waveforms</a>	7.6	10.7	15.7	ns
PWD	Pulse width distortion <sup>(1)</sup> $ t_{PHL} - t_{PLH} $					
$ENIO\_t_{PLH}$ , $ENIO\_t_{PHL}$	ENIO propagation delay time (opposite side)	See <a href="#">Enable/Disable Propagation Delay Time Test Circuit and Waveform</a>		210	473.8	ns
$t_{sk(o)}$	Channel-to-channel output skew time <sup>(2)</sup>	Same-direction channels			4	ns
$t_{sk(pp)}$	Part-to-part skew time <sup>(3)</sup>				5.5	ns
$t_r$	Output signal rise time	See <a href="#">Switching Characteristics Test Circuit and Voltage Waveforms</a>		2.5	3.6	ns
$t_f$	Output signal fall time			2.4	3.5	ns
$t_{PHZ}$	Channel disable propagation delay, high-to-high impedance output	See <a href="#">Enable/Disable Propagation Delay Time Test Circuit and Waveform</a>		217	286	ns
$t_{PLZ}$	Channel disable propagation delay, low-to-high impedance output			217	286	ns
$t_{PZH}$	Channel enable propagation delay, high impedance-to-high output for ISOW7721			237	333	ns
	Channel enable propagation delay, high impedance-to-high output for ISOW7721 with F suffix			237	333	ns
$t_{PZL}$	Channel enable propagation delay, high impedance-to-low output for ISOW7721			237	333	ns
	Channel enable propagation delay, high impedance-to-low output for ISOW7721 with F suffix			237	333	ns
$t_{DO}$	Default output delay time from input power loss	Measured from the time $V_{IO}$ or $V_{ISOIN}$ goes below 1.6 V at 10 mV/ns. See <a href="#">Default Output Delay Time Test Circuit and Voltage Waveforms</a>		0.1	0.3	$\mu\text{s}$
$t_{ie}$	Time interval error	$2^{16} - 1$ PRBS data at 100 Mbps		0.7		ns

(1) Also known as pulse skew.

(2)  $t_{sk(o)}$  is the skew between outputs of a single device with all driving inputs connected together and the outputs switching in the same direction while driving identical loads.

(3)  $t_{sk(pp)}$  is the magnitude of the difference in propagation delay times between any terminals of different devices switching in the same direction while operating at identical supply voltages, temperature, input signals and loads.

## 7.20 Switching Characteristics - 3.3-V Supply

$V_{ISOIN} = 3.3\text{ V} \pm 10\%$ ,  $V_{IO} = 3.3\text{ V} \pm 10\%$ , GND1 = GNDIO, GND2 = GISOIN (over recommended operating conditions unless otherwise noted)

PARAMETER		TEST CONDITIONS	MIN	TYP	MAX	UNIT
$t_{PLH}$ , $t_{PHL}$	Propagation delay time	See <a href="#">Switching Characteristics Test Circuit and Voltage Waveforms</a>	6	11	16.2	ns
PWD	Pulse width distortion <sup>(1)</sup> $ t_{PHL} - t_{PLH} $			0.6	4.7	ns
ENIO_ $t_{PLH}$ , ENIO_ $t_{PHL}$	ENIO propagation delay time (opposite side)	See <a href="#">Enable/Disable Propagation Delay Time Test Circuit and Waveform</a>		220	474	ns
$t_{sk(o)}$	Channel-to-channel output skew time <sup>(2)</sup>	Same-direction channels			4.1	ns
$t_{sk(pp)}$	Part-to-part skew time <sup>(3)</sup>				4.5	ns
$t_r$	Output signal rise time	See <a href="#">Switching Characteristics Test Circuit and Voltage Waveforms</a>		1.8	2.7	ns
$t_f$	Output signal fall time			1.6	2.4	ns
$t_{PHZ}$	Channel disable propagation delay, high-to-high impedance output	See <a href="#">Enable/Disable Propagation Delay Time Test Circuit and Waveform</a>		230	300.4	ns
$t_{PLZ}$	Channel disable propagation delay, low-to-high impedance output			230	299.6	ns
$t_{PZH}$	Channel enable propagation delay, high impedance-to-high output for ISOW7721			226	318.9	ns
	Channel enable propagation delay, high impedance-to-high output for ISOW7721 with F suffix			226	319.1	ns
$t_{PZL}$	Channel enable propagation delay, high impedance-to-low output for ISOW7721			225	317.9	ns
	Channel enable propagation delay, high impedance-to-low output for ISOW7721 with F suffix			225	317.6	ns
$t_{DO}$	Default output delay time from input power loss	Measured from the time $V_{IO}$ or $V_{ISOIN}$ goes below 1.6 V at 10 mV/ns. See <a href="#">Default Output Delay Time Test Circuit and Voltage Waveforms</a>		0.1	0.3	$\mu\text{s}$
$t_{ie}$	Time interval error	$2^{16} - 1$ PRBS data at 100 Mbps		0.65		ns

(1) Also known as pulse skew.

(2)  $t_{sk(o)}$  is the skew between outputs of a single device with all driving inputs connected together and the outputs switching in the same direction while driving identical loads.

(3)  $t_{sk(pp)}$  is the magnitude of the difference in propagation delay times between any terminals of different devices switching in the same direction while operating at identical supply voltages, temperature, input signals and loads.

## 7.21 Switching Characteristics - 2.5-V Supply

$V_{ISOIN} = 2.5\text{ V} \pm 10\%$ ,  $V_{IO} = 2.5\text{ V} \pm 10\%$ , GND1 = GNDIO, GND2 = GISOIN (over recommended operating conditions unless otherwise noted)

PARAMETER		TEST CONDITIONS	MIN	TYP	MAX	UNIT
$t_{PLH}$ , $t_{PHL}$	Propagation delay time	See <a href="#">Switching Characteristics Test Circuit and Voltage Waveforms</a>	7.5	12	18	ns
PWD	Pulse width distortion <sup>(1)</sup> $ t_{PHL} - t_{PLH} $		0.36	5.1	ns	
$ENIO\_t_{PLH}$ , $ENIO\_t_{PHL}$	ENIO propagation delay time (opposite side)	See <a href="#">Enable/Disable Propagation Delay Time Test Circuit and Waveform</a>		225	478	ns
$t_{sk(o)}$	Channel-to-channel output skew time <sup>(2)</sup>	Same-direction channels			4.1	ns
$t_{sk(pp)}$	Part-to-part skew time <sup>(3)</sup>				6	ns
$t_r$	Output signal rise time	See <a href="#">Switching Characteristics Test Circuit and Voltage Waveforms</a>		2	3.26	ns
$t_f$	Output signal fall time		1.8	3.2	ns	
$t_{PHZ}$	Channel disable propagation delay, high-to-high impedance output	See <a href="#">Enable/Disable Propagation Delay Time Test Circuit and Waveform</a>		237	326	ns
$t_{PLZ}$	Channel disable propagation delay, low-to-high impedance output		236	325	ns	
$t_{PZH}$	Channel enable propagation delay, high impedance-to-high output for ISOW7721		228	360	ns	
	Channel enable propagation delay, high impedance-to-high output for ISOW7721 with F suffix		228	360	ns	
$t_{PZL}$	Channel enable propagation delay, high impedance-to-low output for ISOW7721		227	350	ns	
	Channel enable propagation delay, high impedance-to-low output for ISOW7721 with F suffix		227	350	ns	
$t_{DO}$	Default output delay time from input power loss	Measured from the time $V_{IO}$ or $V_{ISOIN}$ goes below 1.6 V at 10 mV/ns. See <a href="#">Default Output Delay Time Test Circuit and Voltage Waveforms</a>		0.1	0.3	$\mu\text{ s}$
$t_{ie}$	Time interval error	$2^{16} - 1$ PRBS data at 100 Mbps		0.7		ns

- (1) Also known as pulse skew.
- (2)  $t_{sk(o)}$  is the skew between outputs of a single device with all driving inputs connected together and the outputs switching in the same direction while driving identical loads.
- (3)  $t_{sk(pp)}$  is the magnitude of the difference in propagation delay times between any terminals of different devices switching in the same direction while operating at identical supply voltages, temperature, input signals and loads.

## 7.22 Switching Characteristics - 1.8-V Supply

$V_{\text{ISOIN}} = 1.8 \text{ V} \pm 5\%$ ,  $V_{\text{IO}} = 1.8 \text{ V} \pm 5\%$ , GND1 = GNDIO, GND2 = GISOIN (over recommended operating conditions unless otherwise noted)

PARAMETER		TEST CONDITIONS	MIN	TYP	MAX	UNIT
$t_{\text{PLH}}$ , $t_{\text{PHL}}$	Propagation delay time	See <a href="#">Switching Characteristics Test Circuit and Voltage Waveforms</a>	7.5	15	21.5	ns
PWD	Pulse width distortion <sup>(1)</sup> $ t_{\text{PHL}} - t_{\text{PLH}} $			0	5.8	ns
ENIO_ $t_{\text{PLH}}$ , ENIO_ $t_{\text{PHL}}$	ENIO propagation delay time (opposite side)	See <a href="#">Enable/Disable Propagation Delay Time Test Circuit and Waveform</a>		243	475	ns
$t_{\text{sk(o)}}$	Channel-to-channel output skew time <sup>(2)</sup>	Same-direction channels			4.1	ns
$t_{\text{sk(pp)}}$	Part-to-part skew time <sup>(3)</sup>				8.6	ns
$t_{\text{r}}$	Output signal rise time	See <a href="#">Switching Characteristics Test Circuit and Voltage Waveforms</a>		1.9	3	ns
$t_{\text{f}}$	Output signal fall time			1.8	3	ns
$t_{\text{PHZ}}$	Channel disable propagation delay, high-to-high impedance output	See <a href="#">Enable/Disable Propagation Delay Time Test Circuit and Waveform</a>		260	410	ns
$t_{\text{PLZ}}$	Channel disable propagation delay, low-to-high impedance output			260	406	ns
$t_{\text{PZH}}$	Channel enable propagation delay, high impedance-to-high output for ISOW7721			240	444	ns
	Channel enable propagation delay, high impedance-to-high output for ISOW7721 with F suffix			240	444	ns
$t_{\text{PZL}}$	Channel enable propagation delay, high impedance-to-low output for ISOW7721			237	439	ns
	Channel enable propagation delay, high impedance-to-low output for ISOW7721 with F suffix			237	439	ns
$t_{\text{DO}}$	Default output delay time from input power loss	Measured from the time $V_{\text{IO}}$ or $V_{\text{ISOIN}}$ goes below 1.6 V at 10 mV/ns. See <a href="#">Default Output Delay Time Test Circuit and Voltage Waveforms</a>		0.1	0.3	$\mu\text{s}$
$t_{\text{ie}}$	Time interval error	$2^{16} - 1$ PRBS data at 100 Mbps		0.7		ns

(1) Also known as pulse skew.

(2)  $t_{\text{sk(o)}}$  is the skew between outputs of a single device with all driving inputs connected together and the outputs switching in the same direction while driving identical loads.

(3)  $t_{\text{sk(pp)}}$  is the magnitude of the difference in propagation delay times between any terminals of different devices switching in the same direction while operating at identical supply voltages, temperature, input signals and loads.

### 7.23 Insulation Characteristics Curves

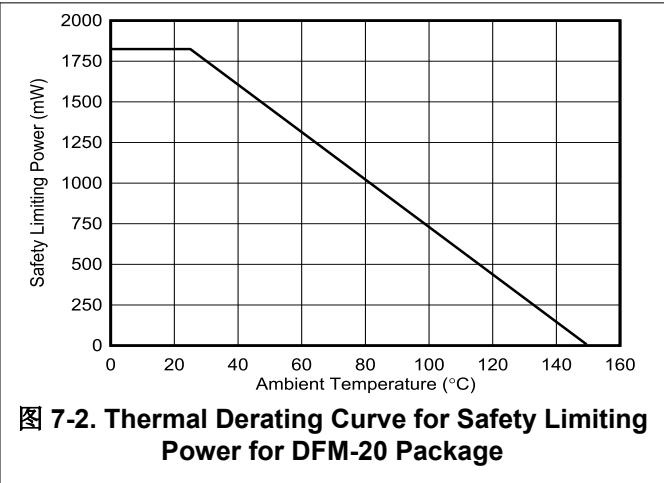
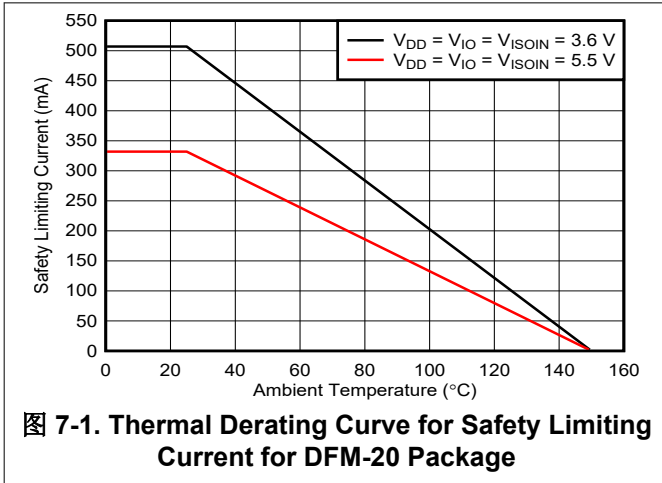

## 7.24 Typical Characteristics



图 7-3. Isolated Supply Voltage ( $V_{ISOOUT}$ ) vs Load Current ( $I_{ISOOUT}$ )



图 7-4. Isolated Supply Voltage ( $V_{ISOOUT}$ ) vs Load Current ( $I_{ISOOUT}$ )

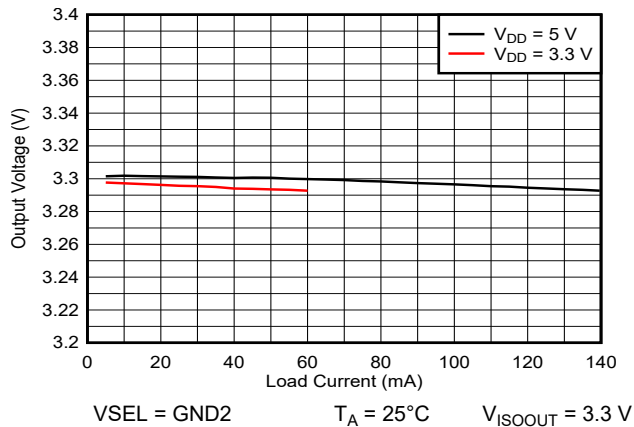

图 7-5. Supply Current ( $I_{DD}$ ) vs Load Current ( $I_{ISOOUT}$ )

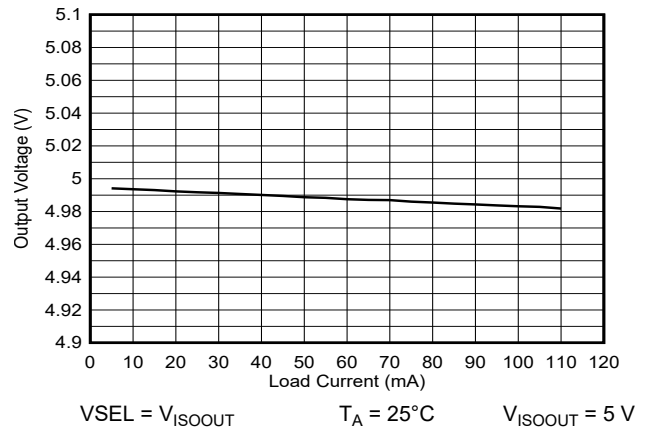

图 7-6. Efficiency vs Load Current ( $I_{ISOOUT}$ )

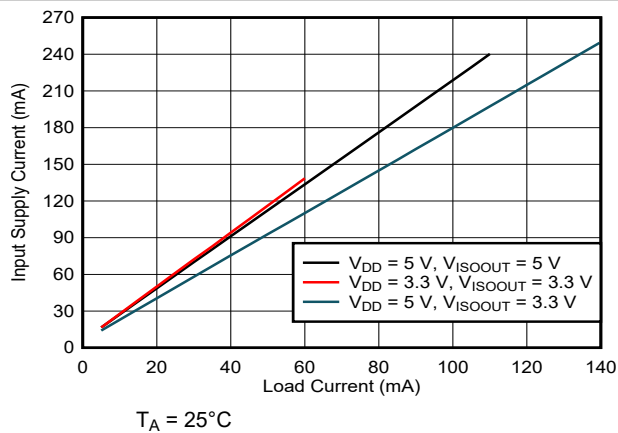

图 7-7. Power Dissipation vs Load Current ( $I_{ISOOUT}$ )

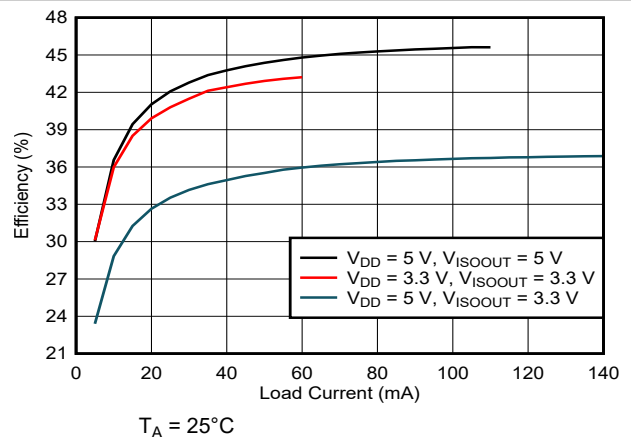

图 7-8. 3.3-V Isolated Supply Voltage ( $V_{ISOOUT}$ ) vs Free-Air Temperature

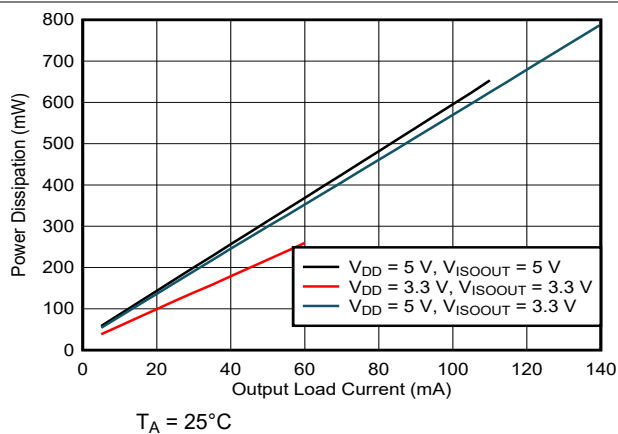

图 7-9. 5-V Isolated Supply Voltage ( $V_{ISOOUT}$ ) vs Free-Air Temperature

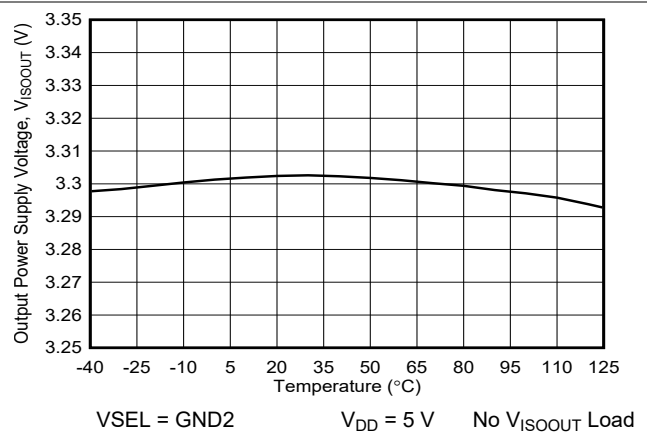

图 7-10. Short-Circuit Supply Current ( $I_{CC}$ ) vs Supply Voltage ( $V_{CC}$ )

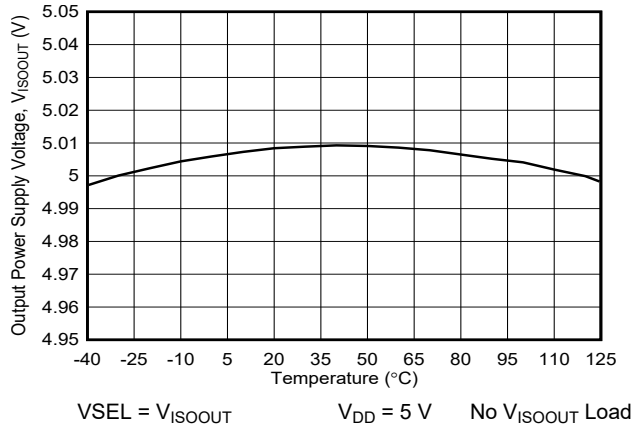

图 7-11. ISOW7721 Channel Supply Currents vs Data Rate For  $C_L = 15\text{pF}$

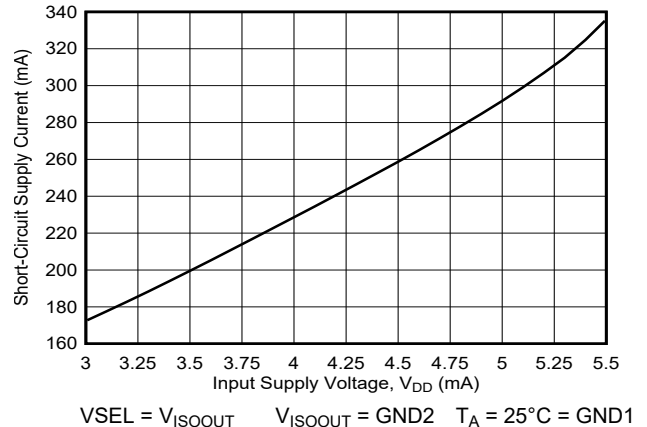

图 7-12. ISOW7721 Channel Supply Currents vs Data Rate For  $C_L = 0\text{pF}$

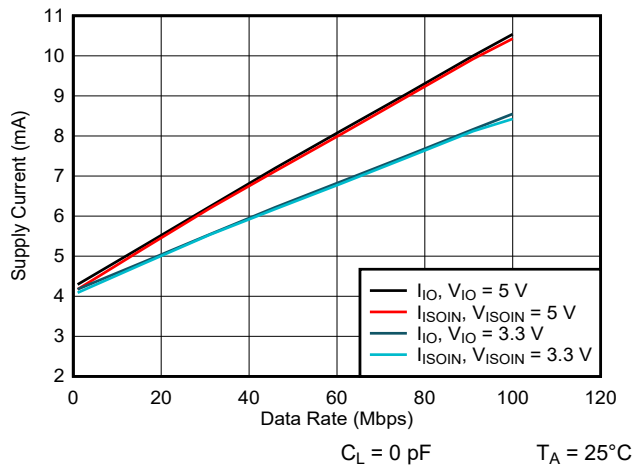

图 7-13. Power-Supply Undervoltage Threshold vs Free Air Temperature

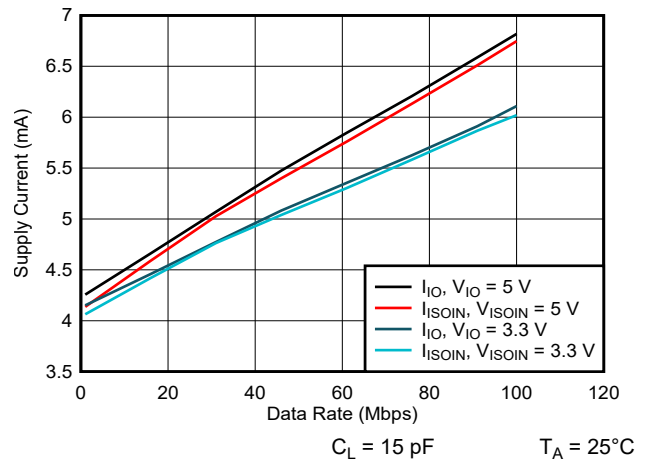

图 7-14. Propagation Delay Time vs Free-Air Temperature

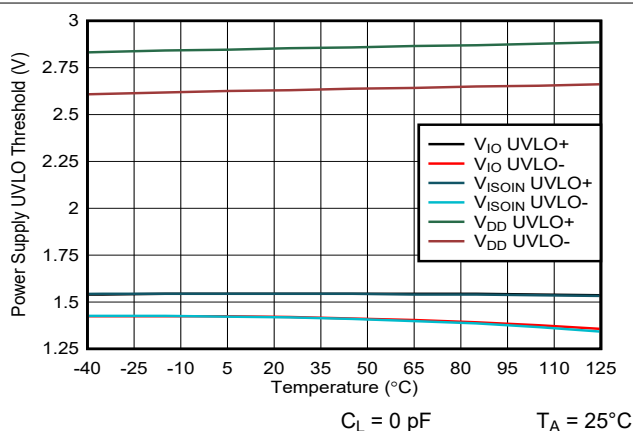

**图 7-15. High-Level Output Voltage vs High-Level Output Current**

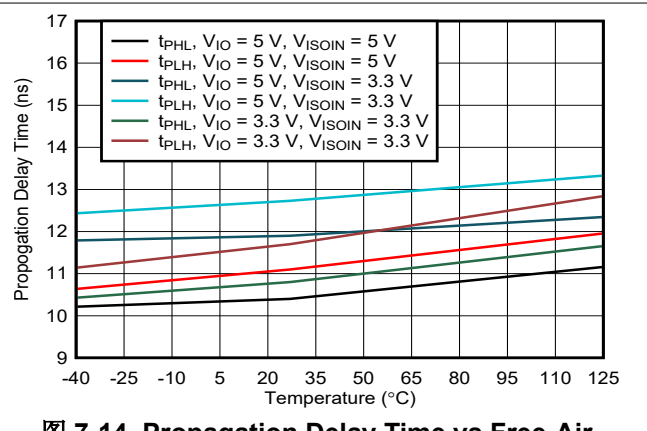
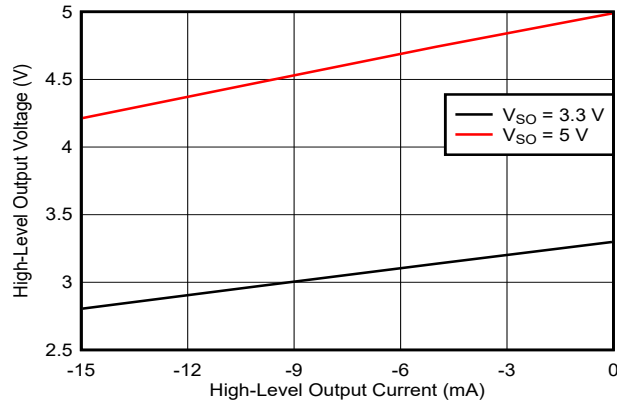
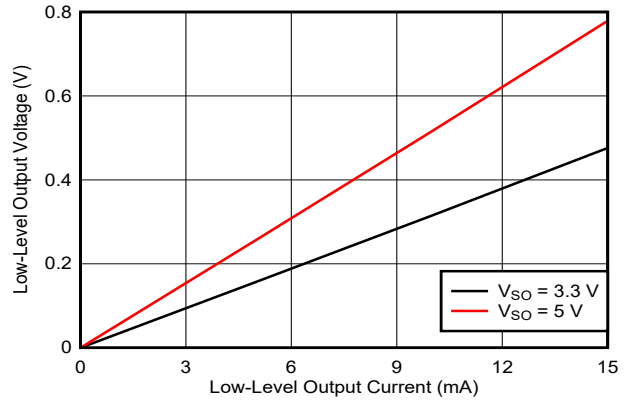

**图 7-16. Low-Level Output Voltage vs Low-Level Output Current**

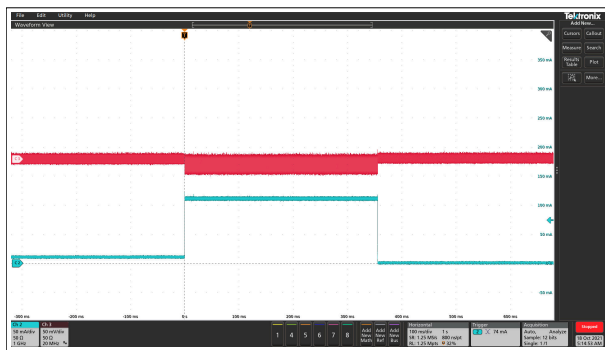

$V_{DD} = 5\text{ V}$   $V_{ISOOUT} = 3.3\text{ V}$   $T_A = 25^\circ\text{C}$

**图 7-17. 10-mA to 110-mA Load Transient Response**

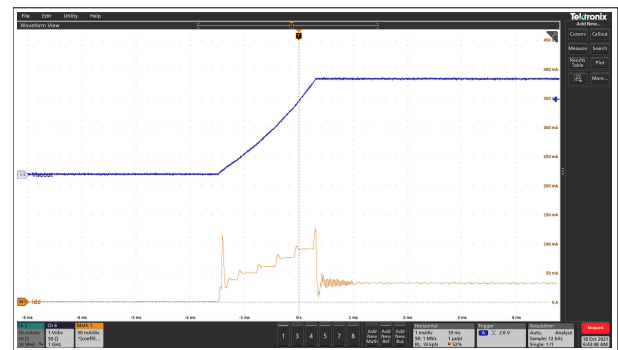

$V_{DD} = 5\text{ V}$   $V_{ISOOUT} = 3.3\text{ V}$   $10\text{ uF}$   
Capacitor on

**图 7-18. Soft Start at 10-mA Load For  $V_{ISOOUT} = 3.3\text{ V}$**

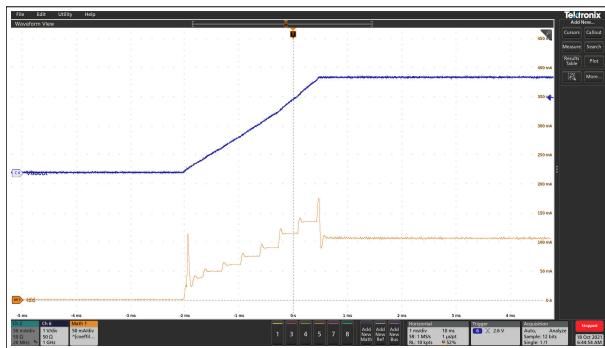

$V_{DD} = 5\text{ V}$   $V_{ISOOUT} = 3.3\text{ V}$   $10\text{ uF}$   
Capacitor on

**图 7-19. Soft Start at 50-mA Load For  $V_{ISOOUT} = 3.3\text{ V}$**

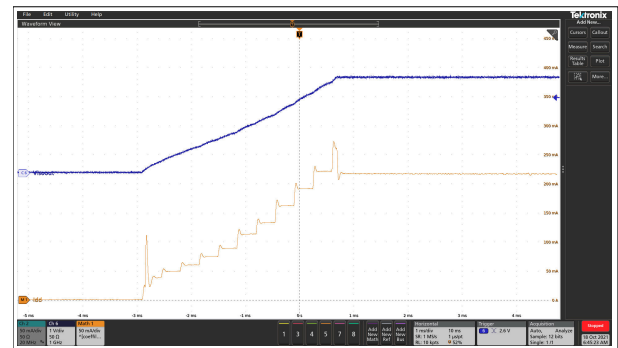

$V_{DD} = 5\text{ V}$   $V_{ISOOUT} = 3.3\text{ V}$   $10\text{ uF}$   
Capacitor on

**图 7-20. Soft Start at 110-mA Load For  $V_{ISOOUT} = 3.3\text{ V}$**

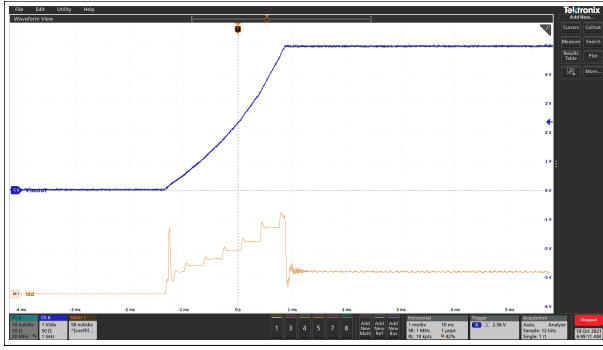

$V_{DD} = 5\text{ V}$   $V_{ISOOUT} = 5\text{ V}$  10 uF  
 Capacitor on  
 $V_{ISOOUT}$

**图 7-21. Soft Start at 10-mA Load For  $V_{ISOOUT} = 5\text{ V}$**

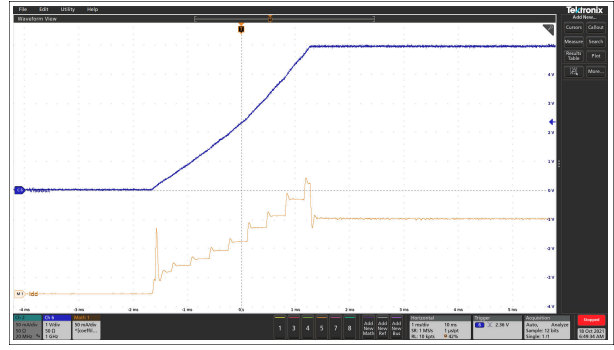

$V_{DD} = 5\text{ V}$   $V_{ISOOUT} = 5\text{ V}$  10 uF  
 Capacitor on  
 $V_{ISOOUT}$

**图 7-22. Soft Start at 50-mA Load For  $V_{ISOOUT} = 5\text{ V}$**

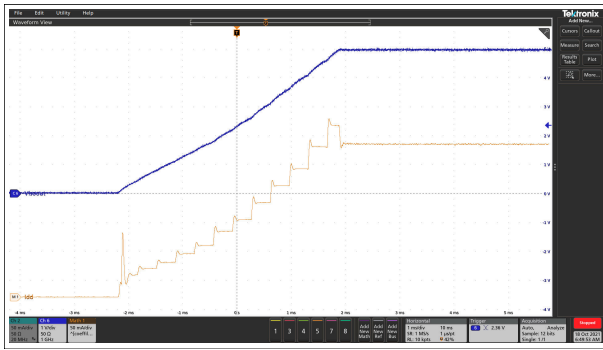

$V_{DD} = 5\text{ V}$   $V_{ISOOUT} = 5\text{ V}$  10 uF  
 Capacitor on  
 $V_{ISOOUT}$

**图 7-23. Soft Start at 110-mA Load For  $V_{ISOOUT} = 5\text{ V}$**

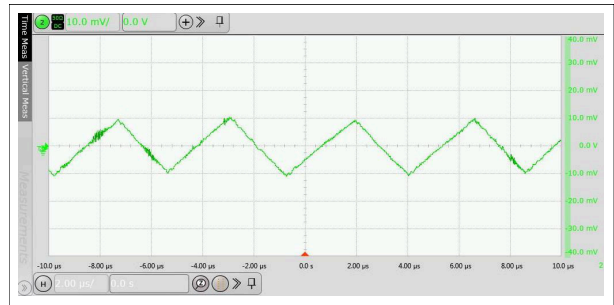

$V_{DD} = 3.3\text{ V}$   $V_{ISOOUT} = 3.3\text{ V}$  10 uF  
 V Capacitor on  
 $V_{ISOOUT}$

**图 7-24.  $V_{ISOOUT}$  Ripple Voltage at 3.3 V with 10 uF Capacitor and 60 mA load**

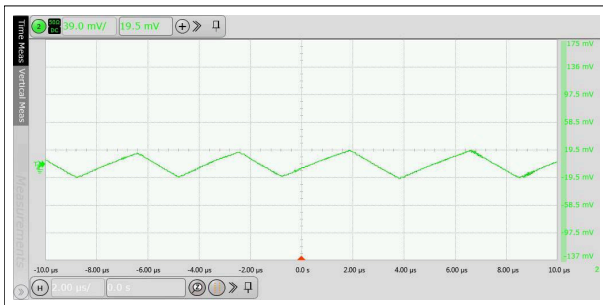

$V_{DD} = 5\text{ V}$   $V_{ISOOUT} = 5\text{ V}$  10 uF  
 Capacitor on  
 $V_{ISOOUT}$

**图 7-25.  $V_{ISOOUT}$  Ripple Voltage at 5 V with 10 uF Capacitor and 110 mA load**

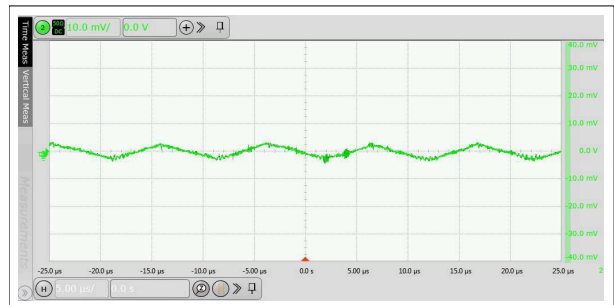

$V_{DD} = 3.3\text{ V}$   $V_{ISOOUT} = 3.3\text{ V}$  100 uF  
 V Capacitor on  
 $V_{ISOOUT}$

**图 7-26.  $V_{ISOOUT}$  Ripple Voltage at 3.3 V with 100 uF Capacitor and 60 mA load**

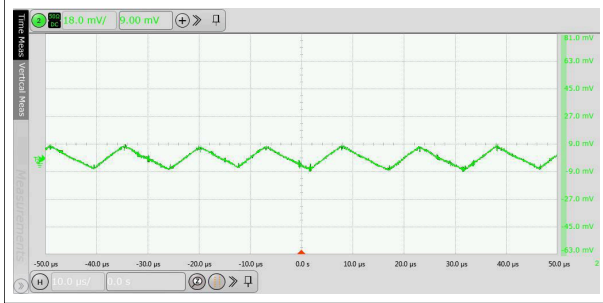

$V_{DD} = 5\text{ V}$   $V_{ISOOUT} = 5\text{ V}$  100  $\mu\text{F}$   
Capacitor on  
 $V_{ISOOUT}$

图 7-27.  $V_{ISOOUT}$  Ripple Voltage at 5 V with 100  $\mu\text{F}$  Capacitor and 110 mA load

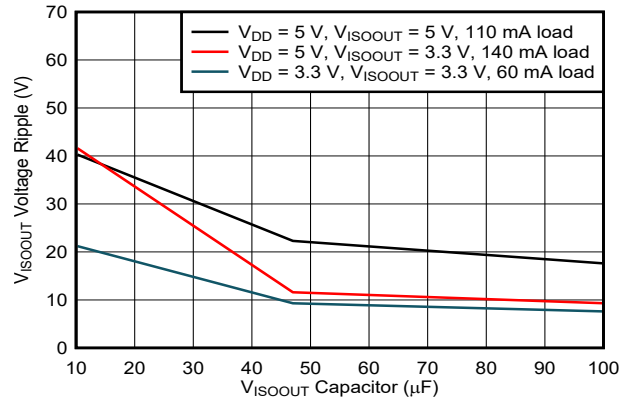

$T_A = 25^\circ\text{C}$

图 7-28.  $V_{ISOOUT}$  Ripple Voltage vs Load Capacitor

## 8 Parameter Measurement Information

In the below images,  $V_{CCI}$  and  $V_{CCO}$  refers to the power supplies  $V_{IO}$  and  $V_{ISOIN}$ , respectively.

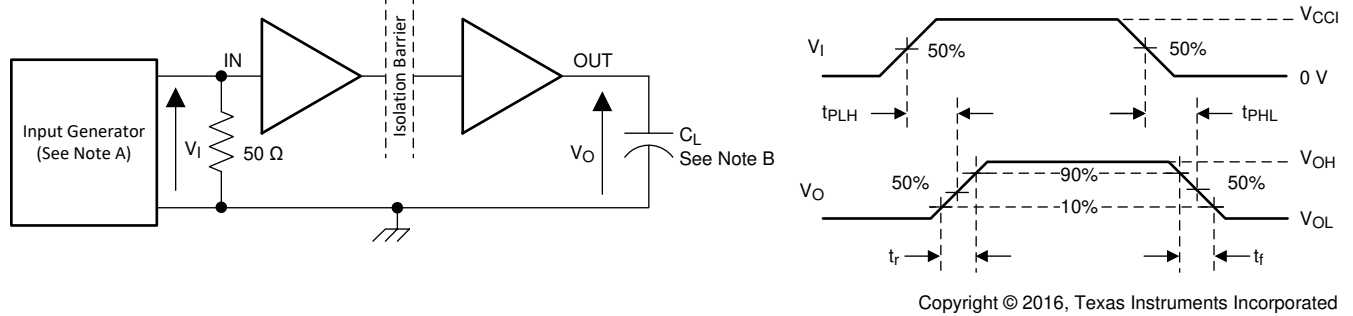

- A.  $C_L = 15$  pF and The input pulse is supplied by a generator having the following characteristics:  $PRR \leq 50$  kHz, 50% duty cycle,  $t_r \leq 3$  ns,  $t_f \leq 3$  ns,  $Z_O = 50 \Omega$ . At the input,  $50 \Omega$  resistor is required to terminate Input Generator signal. It is not needed in actual application.
- B.  $C_L = 15$  pF and includes instrumentation and fixture capacitance within  $\pm 20\%$ .

图 8-1. Switching Characteristics Test Circuit and Voltage Waveforms

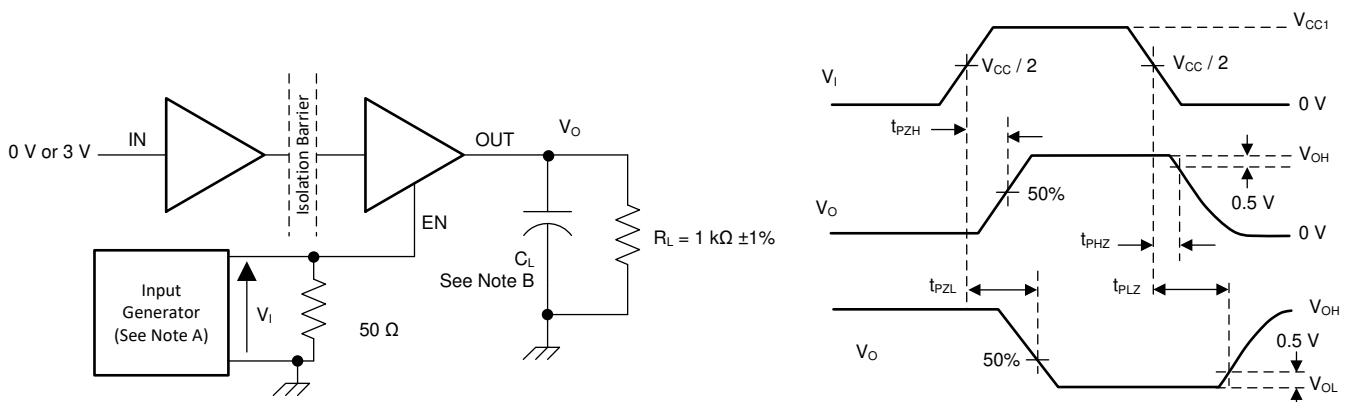

- A. A. The input pulse is supplied by a generator having the following characteristics:  $PRR \leq 50$  kHz, 50% duty cycle,  $t_r \leq 3$  ns,  $t_f \leq 3$  ns,  $Z_O = 50 \Omega$ . At the input,  $50 \Omega$  resistor is required to terminate Input Generator signal. It is not needed in actual application.
- B.  $C_L = 15$  pF and includes instrumentation and fixture capacitance within  $\pm 20\%$ .

图 8-2. Enable/Disable Propagation Delay Time Test Circuit and Waveform

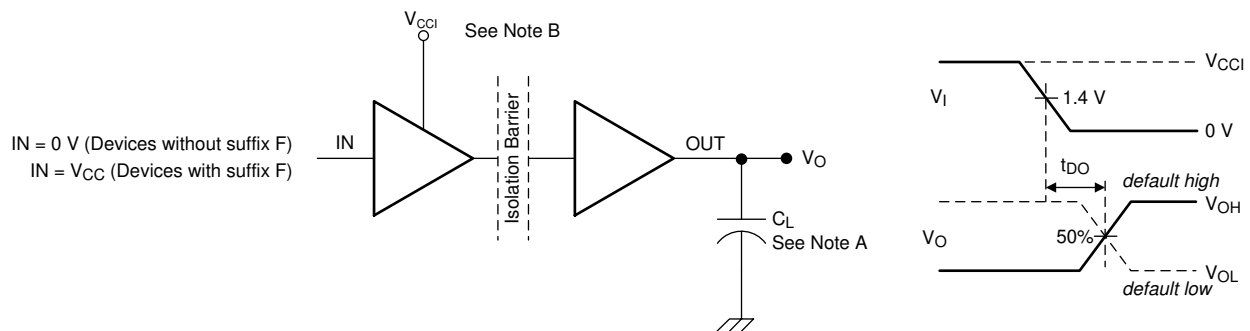

备注

- A.  $C_L = 15$  pF and includes instrumentation and fixture capacitance within  $\pm 20\%$ .



## 9 Detailed Description

### 9.1 Overview

The ISOW7721 family of devices have a low-noise, low-emissions isolated DC-DC converter, and two high-speed isolated data channels. [节 9.2](#) shows the functional block diagram of the ISOW7721 device.

#### 9.1.1 Power Isolation

The integrated isolated DC-DC converter uses advanced circuit and on-chip layout techniques to reduce radiated emissions and achieve up to 46% typical efficiency. The integrated transformer uses thin film polymer as the insulation barrier. Output voltage of power converter can be controlled to 3.3 V or 5 V using  $V_{SEL}$  pin. The DC-DC converter can be switched off using the EN pin to save power. The output voltage,  $V_{ISOOUT}$ , is monitored and feedback information is conveyed to the primary side through a dedicated isolation channel.  $V_{ISOOUT}$  needs to be connected to  $V_{ISOIN}$  to ensure the feedback channel is properly powered to regulate the DC-DC converter. This can be achieved by connecting the pins directly or through an LDO that remains powered up at all times. A ferrite bead is recommended between  $V_{ISOOUT}$  and  $V_{ISOIN}$  to further reduce emissions. See the [节 10.2](#) section. The duty cycle of the primary switching stage is adjusted accordingly. The fast feedback control loop of the power converter ensures low overshoots and undershoots during load transients. Undervoltage lockout (UVLO) with hysteresis is integrated on the  $V_{IO}$ ,  $V_{DD}$  and  $V_{ISOIN}$  supplies which ensures robust fails-safe system performance under noisy conditions. An integrated soft-start mechanism ensures controlled inrush current and avoids any overshoot on the output during power up.

#### 9.1.2 Signal Isolation

The integrated signal isolation channels employ an ON-OFF keying (OOK) modulation scheme to transmit the digital data across a silicon-dioxide based isolation barrier. The transmitter sends a high frequency carrier across the barrier to represent one state and sends no signal to represent the other state. The receiver demodulates the signal after signal conditioning and produces the output through a buffer stage. The signal-isolation channels incorporate advanced circuit techniques to maximize the CMTI performance and minimize the radiated emissions from the high frequency carrier and IO buffer switching. [图 9-1](#) shows a functional block diagram of a typical signal isolation channel. In order to keep any noise coupling from the power converter away from the signal path, power supplies on side 1 for the power converter ( $V_{DD}$ ) and the signal path ( $V_{IO}$ ) are kept separate. Similarly on side 2, the power converter output ( $V_{ISOOUT}$ ) needs to be connected to  $V_{ISOIN}$  externally on PCB. Emissions can be further improved by placing a ferrite bead between  $V_{ISOOUT}$  and  $V_{ISOIN}$  as well as between the GND2 pins. For more details, refer to the [Layout Guidelines section](#).

## 9.2 Functional Block Diagram



图 9-1. Block Diagram



图 9-2. Conceptual Block Diagram of a Capacitive Data Channel

图 9-3 shows a conceptual detail of how the OOK scheme works.

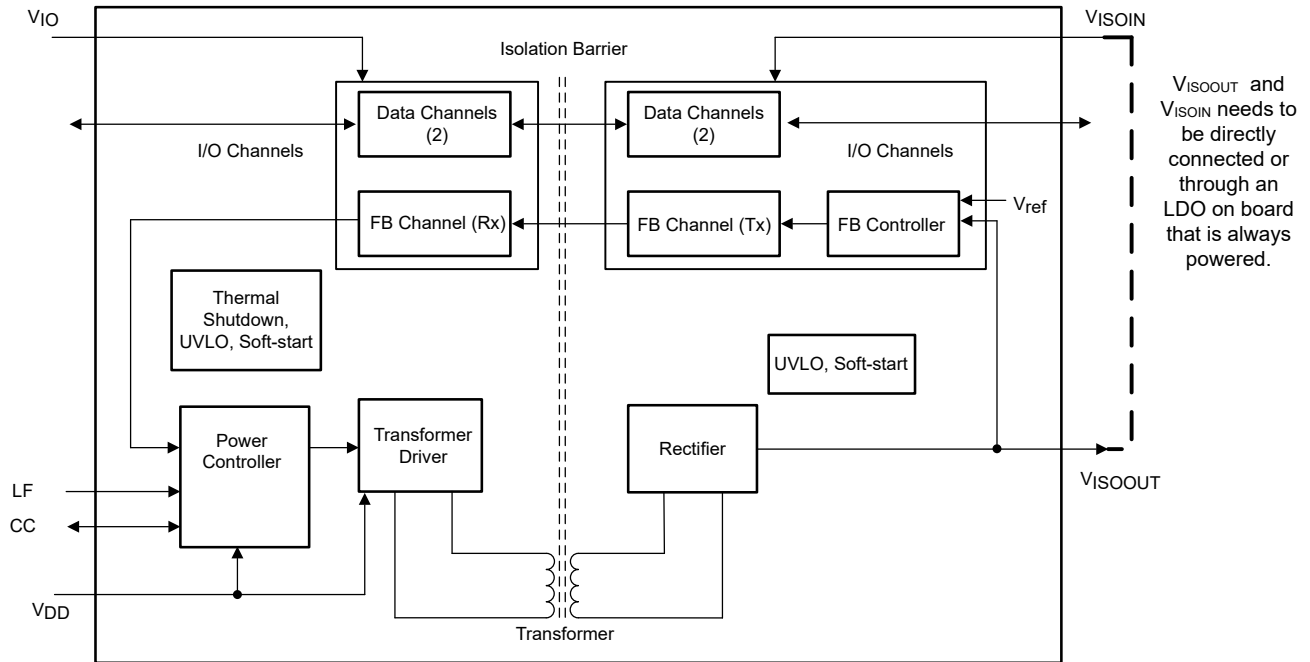

图 9-3. On-Off Keying (OOK) Based Modulation Scheme

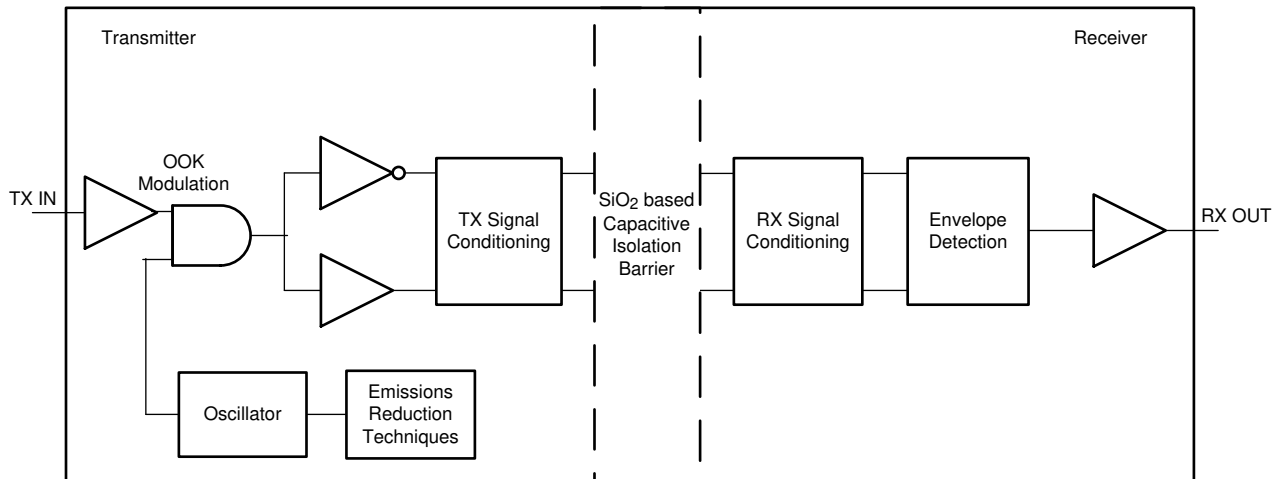
### 9.3 Feature Description

Device Features shows an overview of the device features.

表 9-1. Device Features

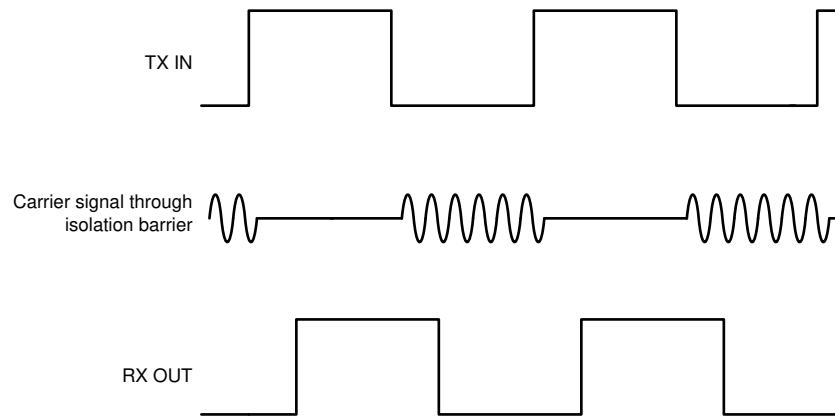
PART NUMBER <sup>(1)</sup>	CHANNEL DIRECTION	MAXIMUM DATA RATE	DEFAULT OUTPUT STATE	RATED ISOLATION <sup>(2)</sup>
ISOW7721	1 forward, 1 reverse	100 Mbps	High	5 kV <sub>RMS</sub> / 7071 V <sub>PK</sub>
ISOW7721 with F suffix			Low	

(1) The F suffix is part of the orderable part number. See the 节 14 section for the full orderable part number.

(2) For detailed isolation ratings, see the 节 7.7 table.

#### 9.3.1 Electromagnetic Compatibility (EMC) Considerations

The ISOW7721 uses emissions reduction schemes for the internal oscillator and advanced internal layout scheme to minimize radiated emissions at the system level.

Many applications in harsh industrial environment are sensitive to disturbances such as electrostatic discharge (ESD), electrical fast transient (EFT), surge and electromagnetic emissions. These electromagnetic disturbances are regulated by international standards such as IEC 61000-4-x and CISPR 32. Although system-level performance and reliability depends, to a large extent, on the application board design and layout, the ISOW7721 incorporates many chip-level design improvements for overall system robustness. Some of these improvements include:

- Robust ESD protection cells for input and output signal pins and inter-chip bond pads.
- Low-resistance connectivity of ESD cells to supply and ground pins.
- Enhanced performance of high voltage isolation capacitor for better tolerance of ESD, EFT and surge events.
- Bigger on-chip decoupling capacitors to bypass undesirable high energy signals through a low impedance path.
- PMOS and NMOS devices isolated from each other by using guard rings to avoid triggering of parasitic SCRs.
- Reduced common mode currents across the isolation barrier by ensuring purely differential internal operation.
- Power path and signal path separated to minimize internal high frequency coupling and an external filtering knob using ferrite beads available to further reduce emissions
- Reduced power converter switching frequency to 25 MHz to reduce strength of high frequency components in emissions spectrum

#### 9.3.2 Power-Up and Power-Down Behavior

The ISOW7721 has built-in UVLO on the V<sub>IO</sub>, V<sub>DD</sub>, and V<sub>ISOIN</sub> supplies with positive-going and negative-going thresholds and hysteresis. Both the power converter supply (VDD) and logic supply (VIO) need to be present for

the device to work. If either of them is below its UVLO, both the signal path and the power converter are disabled.

When the  $V_{DD}$  voltage crosses the positive-going UVLO threshold during power-up, the DC-DC converter initializes and the power converter duty cycle is increased in a controlled manner. This soft-start scheme limits primary peak currents drawn from the  $V_{DD}$  supply and charges the  $V_{ISOOUT}$  output in a controlled manner, avoiding overshoots. Outputs of the isolated data channels are in an indeterminate state until the  $V_{IO}$  and  $V_{DD}$  voltage crosses the positive-going UVLO threshold. When the UVLO positive-going threshold is crossed on the secondary side  $V_{ISOOUT}$  pin, the feedback data channel starts providing feedback to the primary controller. The regulation loop takes over and the isolated data channels go to the normal state defined by the respective input channels or their default states. Design should consider a sufficient time margin (typically 10 ms with 10- $\mu$ F load capacitance) to allow this power up sequence before valid data channels are accounted for system functionality.

When either  $V_{IO}$  or  $V_{DD}$  power is lost, the primary side DC-DC controller turns off when the UVLO lower threshold is reached. The  $V_{ISOOUT}$  capacitor then discharges depending on the external load. The isolated data outputs on the  $V_{ISOIN}$  side are returned to the default state for the brief time that the  $V_{ISOIN}$  voltage takes to discharge to zero.

### 9.3.3 Protection Features

The ISOW7721 has multiple protection features to create a robust system level solution.

- An over-voltage clamp feature is present on  $V_{ISOOUT}$  which will clamp the voltage at 6 V, when  $VSEL = V_{ISOOUT}$ , or 4 V, when  $VSEL = GND2$ , if there is an increase in voltage seen on  $V_{ISOOUT}$ . It is recommended that the  $V_{ISOOUT}$  stays lower than the over-clamp voltage for device reliability.
- Over-voltage lock out on  $V_{DD}$  will occur when a voltage higher than 7 V is seen. The device will go into a low power state and the EN pin will go low.
- The device is protected against output overload and short circuit. Output voltage starts dropping when the power converter is not able to deliver the current demanded during overload conditions. For a  $V_{ISOOUT}$  short-circuit to ground, the duty cycle of the converter is limited to help protect against any damage.
- Thermal protection is also integrated to help prevent the device from getting damaged during overload and short-circuit conditions on the isolated output. Under these conditions, the device temperature starts to increase. When the temperature goes above 165°C, thermal shutdown activates and the primary controller turns off which removes the energy supplied to the  $V_{ISOOUT}$  load, which causes the device to cool off. When the junction temperature goes below 150°C, the device starts to function normally. If an overload or output short-circuit condition prevails, this protection cycle is repeated. Care should be taken in the design to prevent the device junction temperatures from reaching such high values.

### 9.3.4 Multi-Device Chaining for Increased Power Output

The ISOW7721 supports daisy chaining multiple ISOW7721 devices to achieve > 110 mA load as shown in [Figure 9-4](#). The below equation provides an estimate for the required number of ISOW7721 devices to meet a target load current.

$$\text{Number of device} = \text{ceil} \left[ \frac{\text{Target load current} - \text{Maximum available load current}}{0.8 \text{ Maximum available load current}} + 1 \right]$$

Example:

Design a multi-device chaining using ISOW7721 to drive a 680 mA load for  $V_{DD} = 5$  V and  $VSEL = 5$  V.

The Maximum available load current for  $V_{DD} = 5$  V, and  $VSEL = 5$  V is 100 mA from page 1.

$$\text{Number of device} = \text{ceil} \left[ \frac{680 - 110}{0.8 (110)} + 1 \right] = 8$$

From the above calculation, we need 8 ISOW7721 to drive a 680 mA load.

Follow the procedures below to configure multi-device chaining.

1. Set LF to GND1 to make a device as the leader of the daisy chain (only one leader is allowed in a daisy chain). The CC pin of the leader is configured as an output

2. Set LF to  $V_{DD}$  to make the other device as a follower (may use more than one follower to meet your system current requirement). The CC pin of the follower is configured as an input.
3. A voltage change on the LF pin requires a power cycling to put the device into the desired role. Please ensure that all devices are powered during multi-device chaining operation to prevent the VISOOOUT pin of an unpowered device from exposing to an overvoltage condition. An unpowered device can cause the VSEL to set to GND and thus the maximum rating for its VISOOOUT is 4 V. Device damage is possible if this VISOOOUT pin is driven by another 5 V VISOOOUT pin for an extensive long time.
4. Connect the CC pin of the leader to the CC pin of the follower (may use more than one follower) and this will allow the leader to synchronize with the follower.
5. Connect all the VISOOOUT pins and VISOIN pins together for the leader and the follower(s).
6. Connect all the GISOUT pins together for the leader and the follower(s).
7. Connect all the  $V_{DD}$  pins together for the leader and the follower(s).
8. All the VSEL pins should be set to the same logic state.



图 9-4. Multi-Device Chaining

## 9.4 Device Functional Modes

表 9-2 lists the supply configurations for these devices.

**表 9-2. Supply Configuration Function Table**

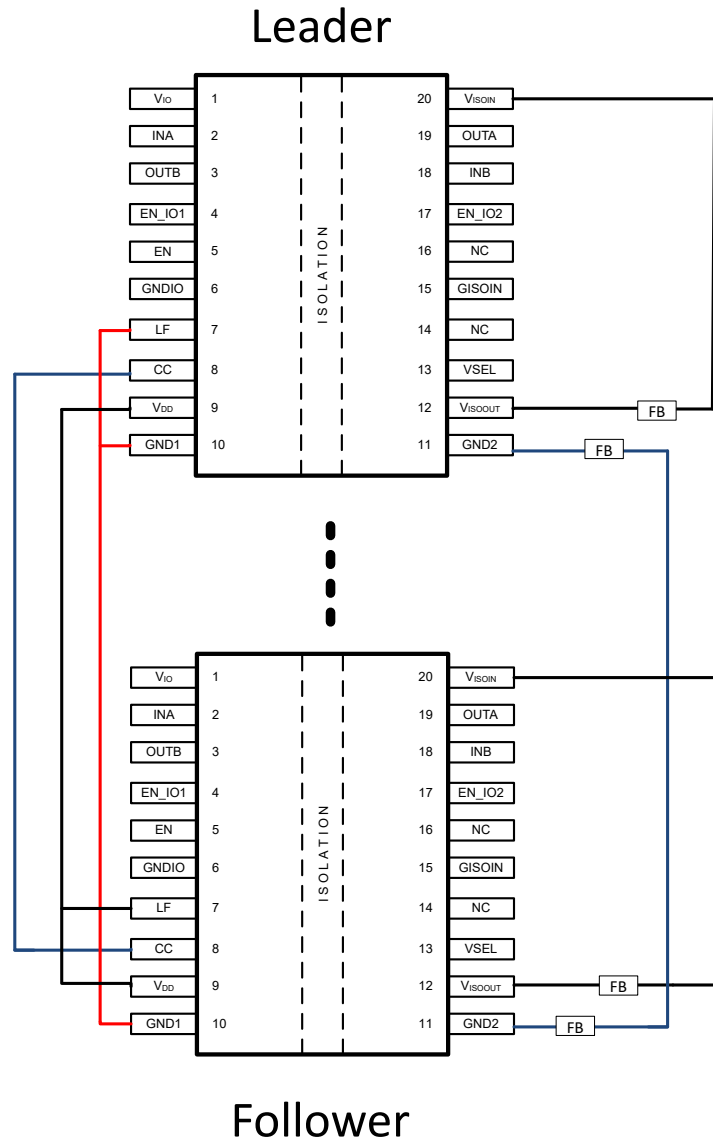
V <sub>DD</sub>	V <sub>IO</sub>	VSEL	V <sub>ISOOUT</sub> <sup>(2)</sup>
< V <sub>DD(UVLO+)</sub>	> V <sub>IO(UVLO+)</sub>	X	OFF
> V <sub>DD(UVLO+)</sub>	< V <sub>IO(UVLO+)</sub>	X	OFF
5 V	1.71 V to 5.5 V	High (shorted to V <sub>ISOOUT</sub> )	5 V
5 V or 3.3 V	1.71 V to 5.5 V	Low (shorted to GND2) <sup>(1)</sup>	3.3 V

- (1) The VSEL pin has a weak pull-down internally. Therefore for V<sub>ISOOUT</sub> = 3.3 V, the VSEL pin should be strongly connected to the GND2 pin in noisy system scenarios.  
(2) V<sub>ISOOUT</sub> shorted to V<sub>ISOIN</sub> on PCB and both GND2 and GISOIN pins are shorted to each other and EN=High

表 9-3 lists the channel isolators functional modes for these devices.

**表 9-3. Channel Isolator Function Table**

CHANNEL INPUT SUPPLY (V <sub>CCI</sub> ) <sup>(1)</sup>	CHANNEL OUTPUT SUPPLY (V <sub>CCO</sub> ) <sup>(1)</sup>	INPUT (IN <sub>x</sub> )	IO ENABLE (EN <sub>IOx</sub> )	OUTPUT (OUT <sub>x</sub> )	COMMENTS
PU	PU	H	H or Open	H	Normal Operation: A channel output assumes the logic state of its input.
		L	H or Open	L	
		Open	H or Open	Default	Default mode <sup>(2)</sup> : When IN <sub>x</sub> is open, the corresponding channel output goes to its default logic state.
		X	L	Z and Default	A low value of output enable causes the outputs of the same side to be high impedance and the output of opposite side to be fail-safe default state.
PD	PU	X	H or Open	Default	Default mode <sup>(2)</sup> : When V <sub>CCI</sub> is unpowered, a channel output assumes the logic state based on the selected default option. When V <sub>CCI</sub> transitions from unpowered to powered-up, a channel output assumes the logic state of the input. When V <sub>CCI</sub> transitions from powered-up to unpowered, channel output assumes the selected default state.

- (1) V<sub>CCI</sub> = Input-side V<sub>IO</sub> or V<sub>ISOIN</sub>; V<sub>CCO</sub> = Output-side V<sub>IO</sub> or V<sub>ISOIN</sub>; PU = Powered up (V<sub>IO</sub> > 1.7 V, V<sub>ISOIN</sub> > 1.7 V); PD = Powered down (V<sub>IO</sub> < 1 V, V<sub>ISOIN</sub> < 1 V); X = Irrelevant; H = High level; L = Low level.  
(2) In the default condition, the output is high for the ISOW7721 and low with the F suffix.

### 9.4.1 Device I/O Schematics



图 9-5. Device I/O Schematics

## 10 Application and Implementation

### 备注

Information in the following applications sections is not part of the TI component specification, and TI does not warrant its accuracy or completeness. TI's customers are responsible for determining suitability of components for their purposes. Customers should validate and test their design implementation to confirm system functionality.

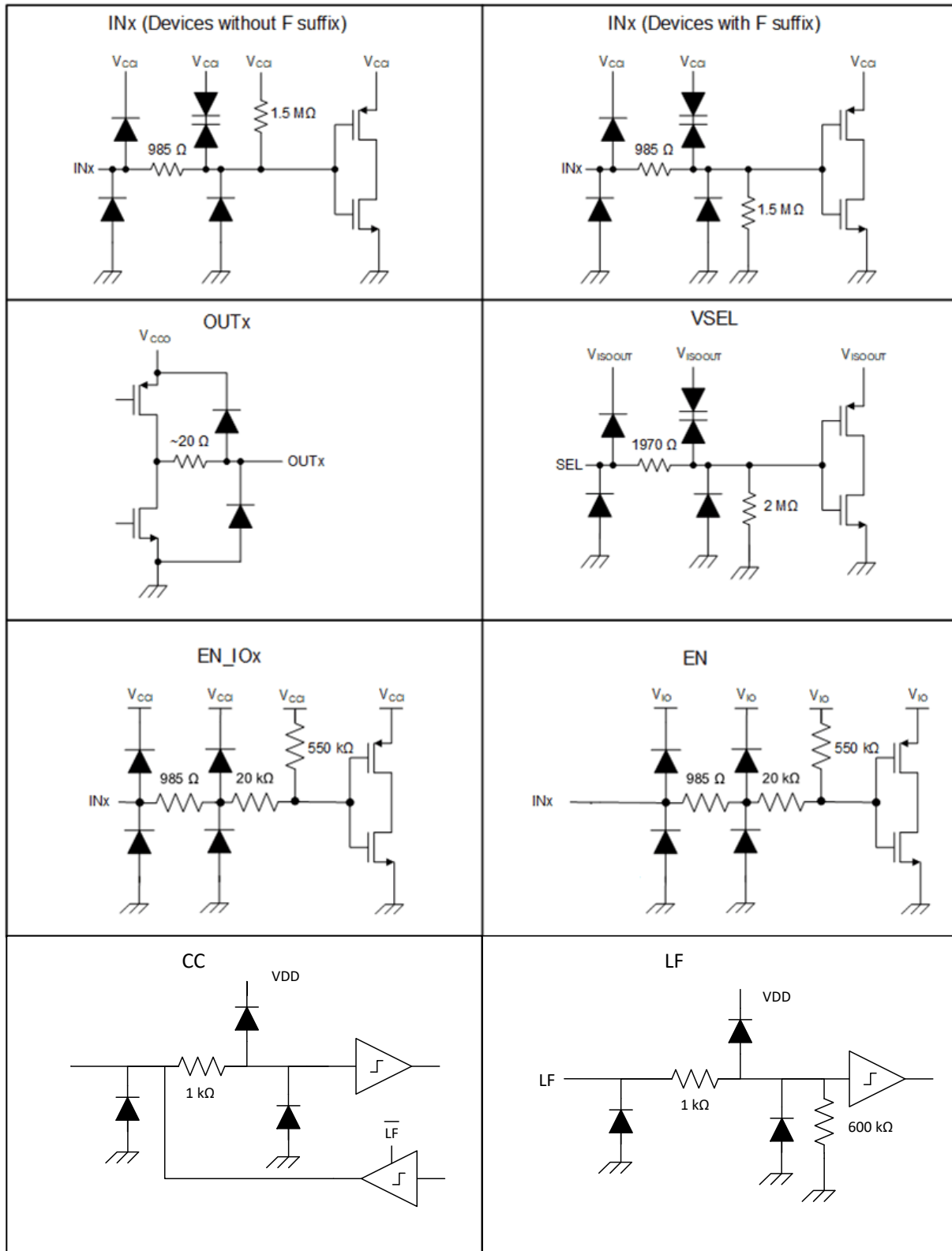
### 10.1 Application Information

This device is a high-performance, two channel digital isolator with integrated DC-DC converter. Typically digital isolators require two power supplies isolated from each other to power up both sides of device. Due to the integrated DC-DC converter in the device, the isolated supply is generated inside the device that can be used to power isolated side of the device and peripherals on isolated side, thus saving board space. The device uses single-ended CMOS-logic switching technology. When designing with digital isolators, keep in mind that because of the single-ended design structure, digital isolators do not conform to any specific interface standard and are only intended for isolating single-ended CMOS or TTL digital signal lines. The isolator is typically placed between the data controller (Microcontroller or UART), and a data converter or a line transceiver, regardless of the interface type or standard.

The device is suitable for applications that have limited board space and desire more integration. The device is also suitable for very high voltage applications, where power transformers meeting the required isolation specifications are bulky and expensive.

### 10.2 Typical Application



For step-by-step design procedure, circuit schematics, bill of materials, printed circuit board (PCB) files, simulation results, and test results, refer to [TI Design TIDA-01333, Eight-Channel, Isolated, High-Voltage Analog Input Module With ISOW7841 Reference Design](#).

图 10-1 shows the typical schematic for SPI isolation.



图 10-1. Isolated Power and UART for ADC Sensing Application with ISOW7721

## 10.2.1 Design Requirements

To design with this device, use the parameters listed in [表 10-1](#).

**表 10-1. Design Parameters**

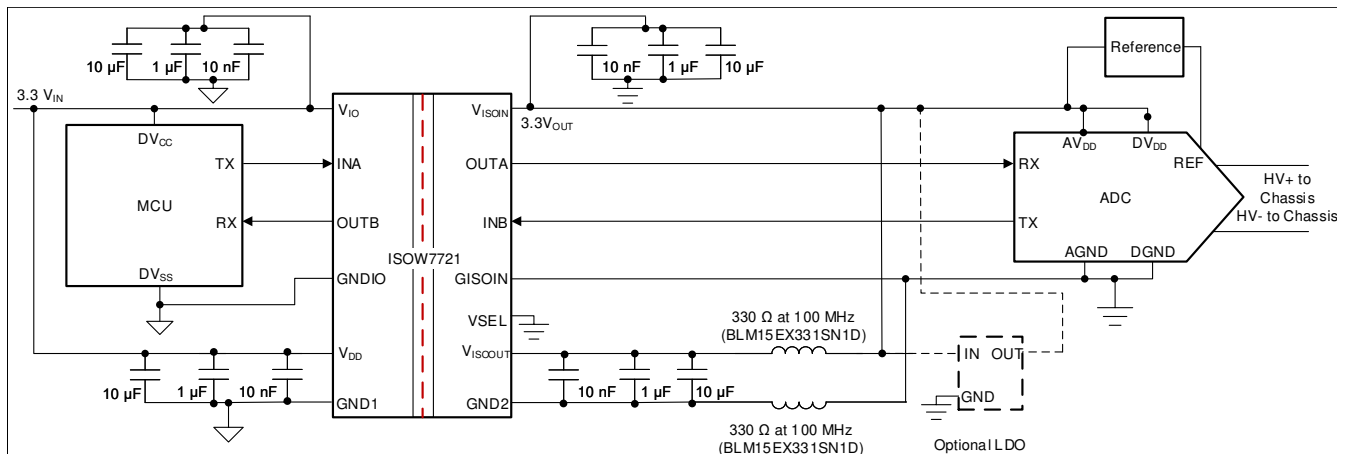
PARAMETER	VALUE
$V_{DD}$ input voltage	3 V to 5.5 V
$V_{IO}$ input voltage	1.71 V to 5.5 V
$V_{ISOIN}$ input voltage	1.71 V to 5.5 V
$V_{DD}$ decoupling capacitors	10 $\mu$ F + 1 $\mu$ F + 0.01 $\mu$ F + optional additional capacitance
$V_{IO}$ decoupling capacitors	0.1 $\mu$ F + optional additional capacitance
$V_{ISOIN}$ decoupling capacitors	0.1 $\mu$ F + optional additional capacitance
$V_{ISOOUT}$ decoupling capacitors	10 $\mu$ F + 1 $\mu$ F + 0.01 $\mu$ F + optional additional capacitance
$V_{ISOOUT}$ to $V_{ISOIN}$ series inductor	BLM15ELX9331SN1D
GND2 to GISOIN series inductor	BLM15ELX9331SN1D
$V_{IO}$ series inductor	BLM15ELX9331SN1D
$V_{DD}$ series inductor	BLM15ELX9331SN1D

Because of very-high current flowing through the ISOW7721  $V_{DD}$  and  $V_{ISOOUT}$  supplies, higher decoupling capacitors typically provide better noise and ripple performance. Although a 10- $\mu$ F capacitor is adequate, higher decoupling capacitors (such as 47  $\mu$ F) on both the  $V_{DD}$  and  $V_{ISOOUT}$  pins to the respective grounds are strongly recommended to achieve the best performance.

## 10.2.2 Detailed Design Procedure

The devices requires specific placement of external bypass capacitors and ferrite beads to operate at high performance. These low-ESR ceramic bypass capacitors must be placed as close to the chip pads as possible.



图 10-2. Typical ISOW7721 Circuit Hook-Up

### 10.2.3 Application Curve

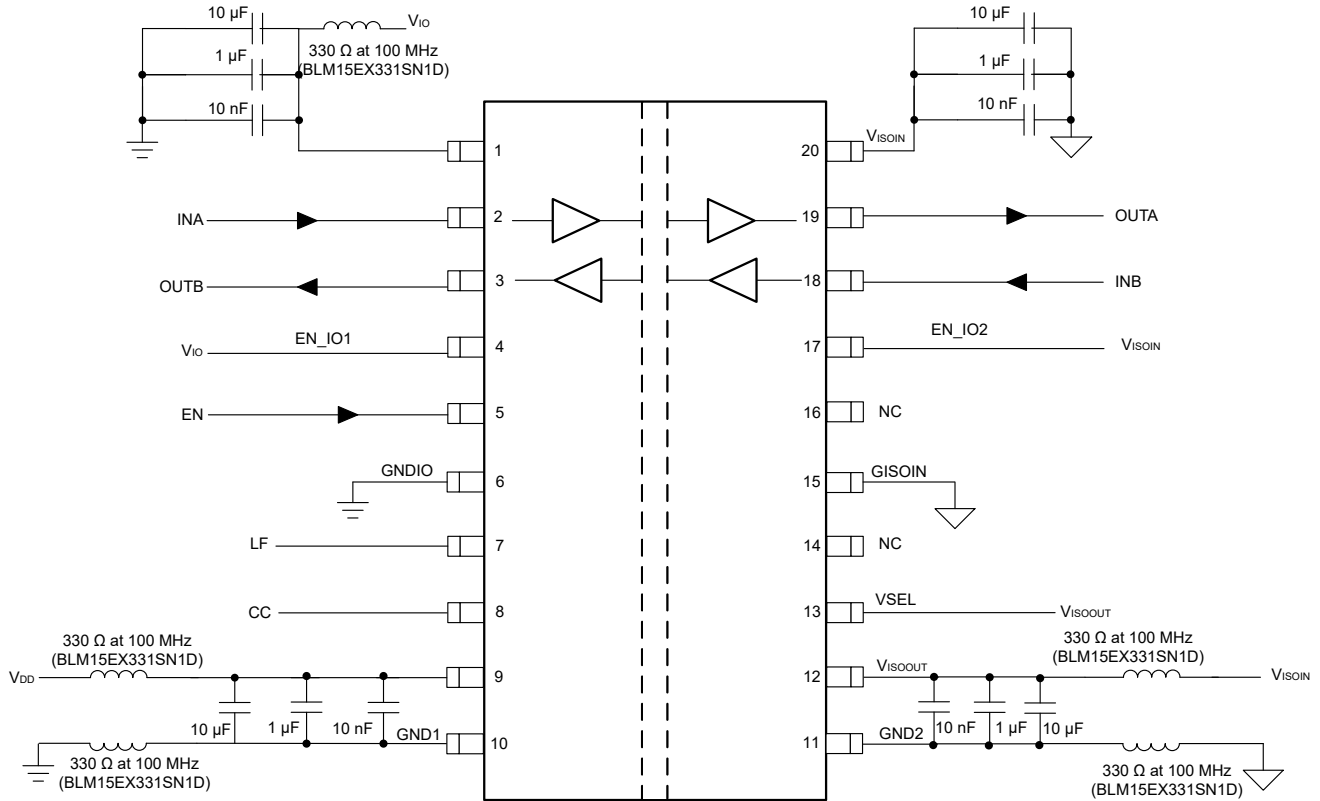
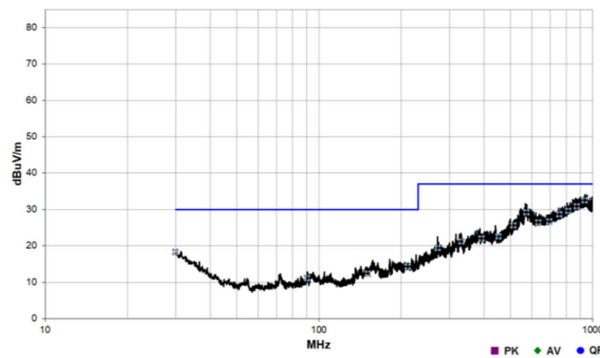

$V_{DD} = 5\text{ V}$

$V_{ISOOUT} = 5\text{ V}$

$I_{ISOOUT} = 100\text{ mA}$

图 10-3. ISOW77xx Radiated Emissions versus CISPR32B line (Blue)

### 10.2.4 Insulation Lifetime

Insulation lifetime projection data is collected by using industry-standard Time Dependent Dielectric Breakdown (TDDB) test method. In this test, all pins on each side of the barrier are tied together creating a two-terminal device and high voltage applied between the two sides; See 图 10-4 for TDDB test setup. The insulation breakdown data is collected at various high voltages switching at 60 Hz over temperature. For reinforced insulation, VDE standard requires the use of TDDB projection line with failure rate of less than 1 part per million (ppm). Even though the expected minimum insulation lifetime is 20 years at the specified working isolation voltage, VDE reinforced certification requires additional safety margin of 20% for working voltage and 87.5% for

lifetime which translates into minimum required insulation lifetime of 37.5 years at a working voltage that's 20% higher than the specified value.

Figure 10-5 shows the intrinsic capability of the isolation barrier to withstand high voltage stress over its lifetime. Based on the TDDB data, the intrinsic capability of the insulation is 1000 V<sub>RMS</sub> with a lifetime of 1184 years.

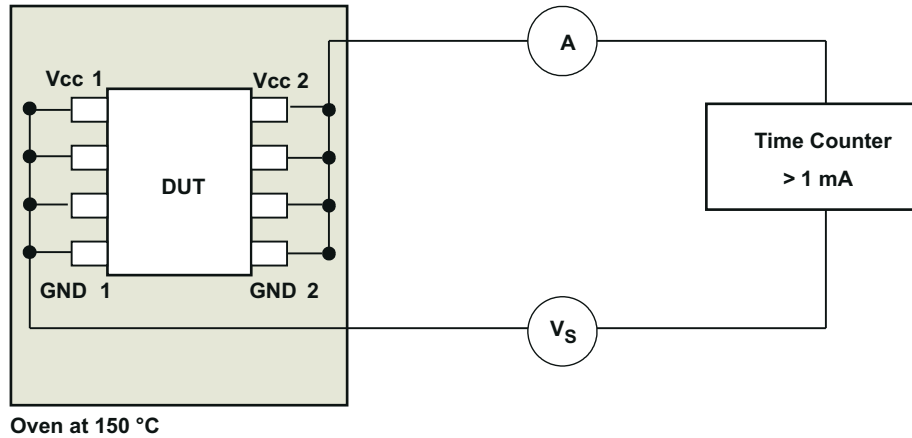

Figure 10-4. Test Setup for Insulation Lifetime Measurement

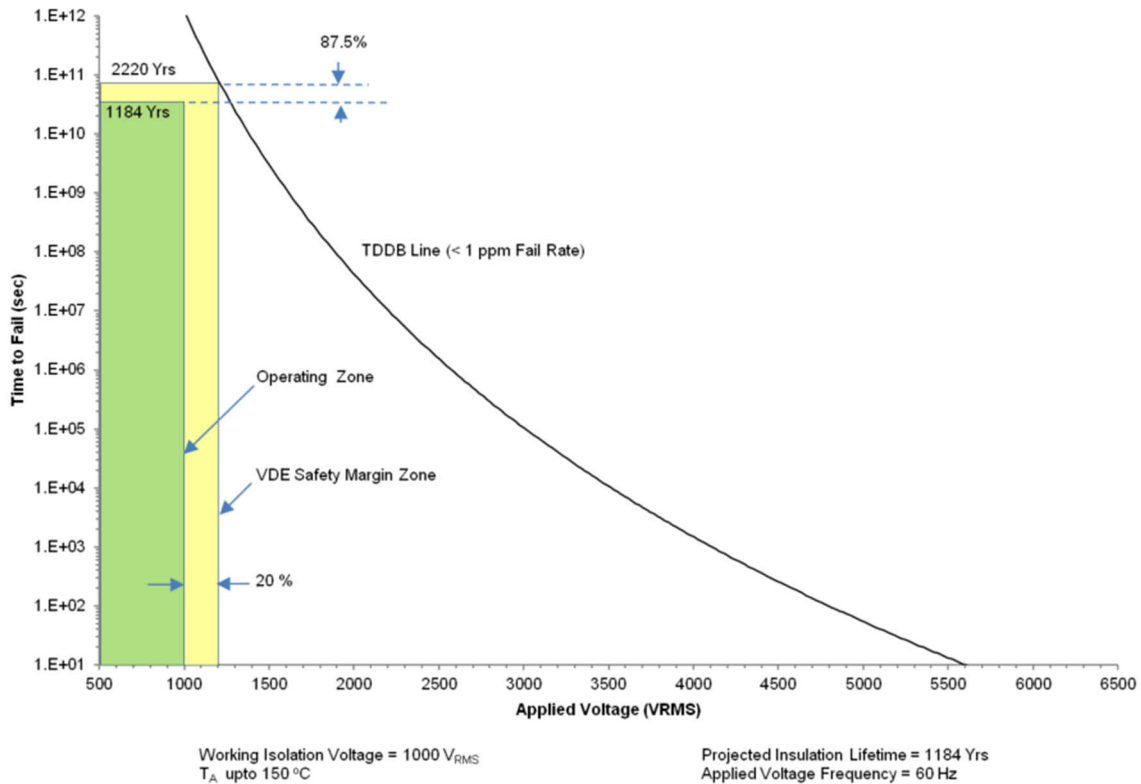

Figure 10-5. Insulation Lifetime Projection Data

## 11 Power Supply Recommendations

To help make sure that operation is reliable at data rates and supply voltages, adequate decoupling capacitors must be located as close to supply pins as possible.  $V_{ISOOUT}$  needs to be connected to  $V_{ISOIN}$  to ensure the feedback channel is properly powered to regulate the DC-DC converter. If  $V_{ISOOUT}$  and  $V_{ISOIN}$  are not connected, the DC-DC converter will run open loop and the  $V_{ISOOUT}$  voltage will drift until the over-voltage clamp clamps at 6 V. There are two ways to connect  $V_{ISOOUT}$  and  $V_{ISOIN}$ :

- 1) Connect  $V_{ISOOUT}$  and  $V_{ISOIN}$  directly with a ferrite bead. A ferrite bead is recommended between  $V_{ISOOUT}$  and  $V_{ISOIN}$  to further reduce emissions.
- 2) Connect  $V_{ISOOUT}$  and  $V_{ISOIN}$  with a ferrite bead through an LDO that remains powered up at all times. If the LDO has an EN pin then keep the EN high at all times.

The input supply ( $V_{IO}$  and  $V_{DD}$ ) must have an appropriate current rating to support output load and switching at the maximum data rate required by the end application. For more information, refer to the [节 10.2](#) section.

For an output load current of 110 mA, it is recommended to have >600 mA of input current limit and for lower output load currents, the input current limit can be proportionally lower.

## 12 Layout

### 12.1 Layout Guidelines

A low cost two layer PCB should be sufficient to achieve good EMC performance:

- Routing the high-speed traces on the top layer avoids the use of vias (and the introduction of their inductances) and allows for clean interconnects between the isolator and the transmitter and receiver circuits of the data link.
- Placing a solid ground plane next to the high-speed signal layer establishes controlled impedance for transmission line interconnects and provides an excellent low-inductance path for the return current flow.
- Placing the power plane next to the ground plane creates additional high-frequency bypass capacitance of approximately 100 pF/in<sup>2</sup>.
- Routing the slower speed control signals on the bottom layer allows for greater flexibility as these signal links usually have margin to tolerate discontinuities such as vias.

If an additional supply voltage plane or signal layer is needed, add a second power or ground plane system to the stack to keep it symmetrical. This makes the stack mechanically stable and prevents it from warping. Also the power and ground plane of each power system can be placed closer together, thus increasing the high-frequency bypass capacitance significantly.

Because the device has no thermal pad to dissipate heat, the device dissipates heat through the respective GND pins. Ensure that enough copper is present on both GND pins to prevent the internal junction temperature of the device from rising to unacceptable levels.

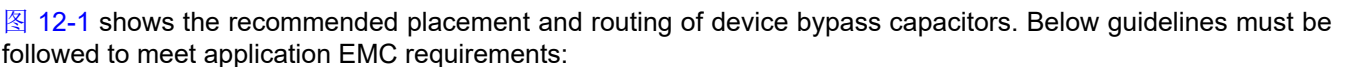
 **Figure 12-1** shows the recommended placement and routing of device bypass capacitors. Below guidelines must be followed to meet application EMC requirements:

- High frequency bypass capacitors 10 nF must be placed close to  $V_{DD}$  and  $V_{ISOOUT}$  pins, less than 1 mm distance away from device pins. This is very essential for optimised radiated emissions performance. Ensure that these capacitors are 0402 size so that they offer least inductance (ESL).
- Bulk capacitors of at least 10  $\mu$ F must be placed on power converter input ( $V_{DD}$ ) and output ( $V_{ISOOUT}$ ) supply pins.
- Traces on  $V_{DD}$  and GND1 must be symmetric till bypass capacitors. Similarly traces on  $V_{ISOOUT}$  and GND2 must be symmetric.
- Place two 0402 size Ferrite beads (Part number: BLM15EX331SN1) on  $V_{ISOOUT}$  and GND2 path so that any high frequency noise from power converter output sees a high impedance before it goes to other components on PCB.
- Do not have any metal traces or ground pour within 4 mm of power converter output terminals  $V_{ISOOUT}$  pin12 and GND2 pin11. VSEL pin is also in  $V_{ISOOUT}$  domain and should be shorted to either pin 11 or pin 12 for output voltage selection.
- Following the layout guidelines of EVM as much as possible is highly recommended for a low radiated emissions design.

#### 12.1.1 PCB Material

For digital circuit boards operating at less than 150 Mbps, (or rise and fall times greater than 1 ns), and trace lengths of up to 10 inches, use standard FR-4 UL94V-0 printed circuit board. This PCB is preferred over cheaper alternatives because of lower dielectric losses at high frequencies, less moisture absorption, greater strength and stiffness, and the self-extinguishing flammability-characteristics.

## 12.2 Layout Example



图 12-1. Layout Example

## 13 Device and Documentation Support

### 13.1 Device Support

#### 13.1.1 Development Support

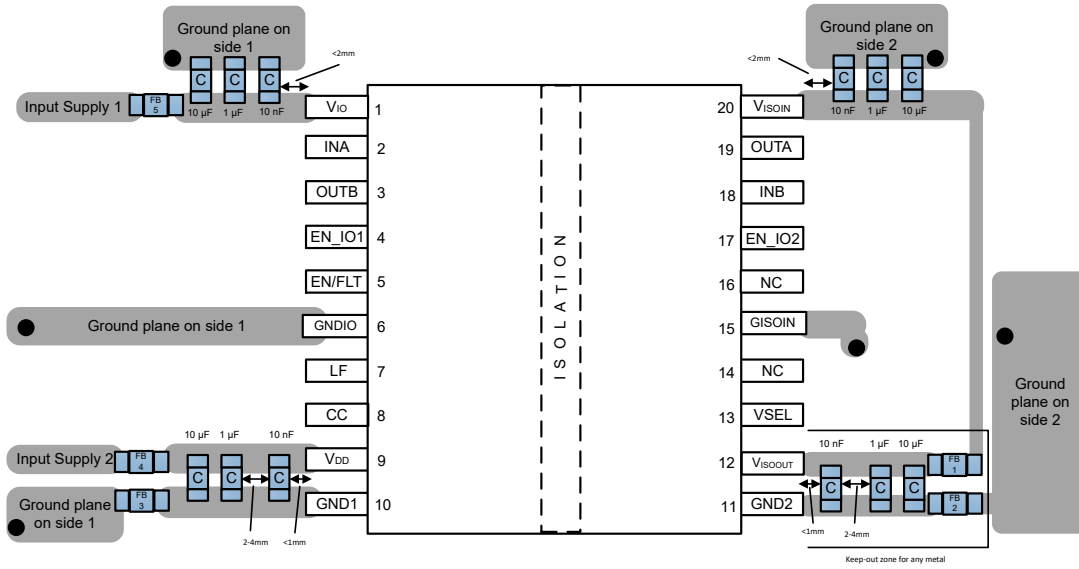
For development support, refer to:

- [8-ch Isolated High Voltage Analog Input Module with ISOW7841 Reference Design](#)
- [Isolated RS-485 With Integrated Signal and Power Reference Design](#)
- [Isolated RS-232 With Integrated Signal and Power Reference Design](#)

### 13.2 Documentation Support

#### 13.2.1 Related Documentation

For related documentation see the following:

- Texas Instruments, [Digital Isolator Design Guide](#)
- Texas Instruments, [Isolation Glossary](#)

### 13.3 Receiving Notification of Documentation Updates

To receive notification of documentation updates, navigate to the device product folder on ti.com. In the upper right corner, click on *Alert me* to register and receive a weekly digest of any product information that has changed. For change details, review the revision history included in any revised document.

### 13.4 支持资源

TI E2E™ 支持论坛是工程师的重要参考资料，可直接从专家获得快速、经过验证的解答和设计帮助。搜索现有解答或提出自己的问题可获得所需的快速设计帮助。

链接的内容由各个贡献者“按原样”提供。这些内容并不构成 TI 技术规范，并且不一定反映 TI 的观点；请参阅 TI 的《使用条款》。

### 13.5 Trademarks

TI E2E™ is a trademark of Texas Instruments.

所有商标均为其各自所有者的财产。

### 13.6 Electrostatic Discharge Caution



This integrated circuit can be damaged by ESD. Texas Instruments recommends that all integrated circuits be handled with appropriate precautions. Failure to observe proper handling and installation procedures can cause damage.

ESD damage can range from subtle performance degradation to complete device failure. Precision integrated circuits may be more susceptible to damage because very small parametric changes could cause the device not to meet its published specifications.

### 13.7 术语表

#### TI 术语表

本术语表列出并解释了术语、首字母缩略词和定义。

## **14 Mechanical, Packaging, and Orderable Information**

The following pages include mechanical, packaging, and orderable information. This information is the most current data available for the designated devices. This data is subject to change without notice and revision of this document. For browser-based versions of this data sheet, refer to the left-hand navigation.

## PACKAGE OUTLINE

### DFM0020A

### SOIC - 3.55 mm max height

SMALL OUTLINE PACKAGE

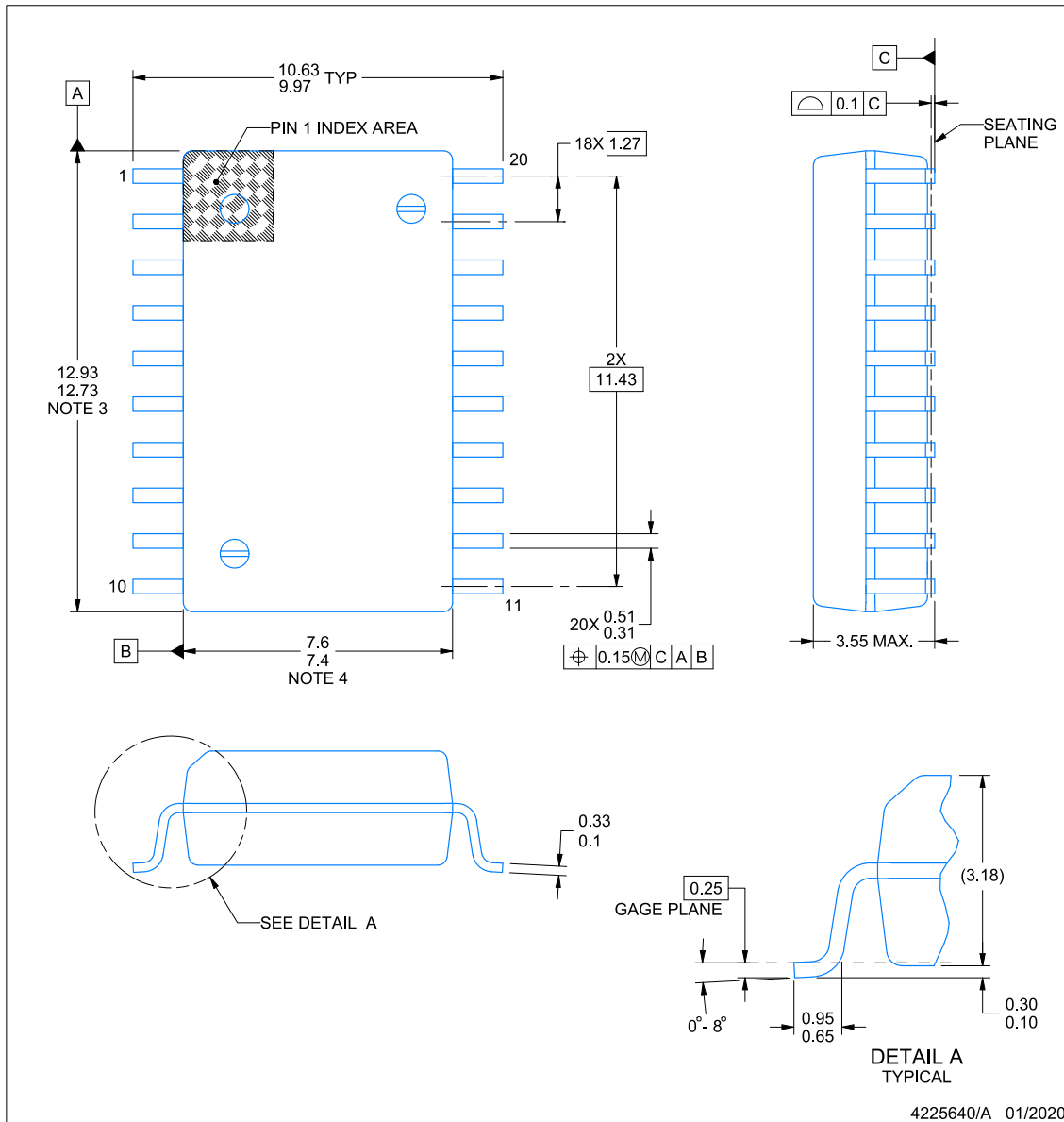

NOTES:

1. All linear dimensions are in millimeters. Any dimensions in parenthesis are for reference only. Dimensioning and tolerancing per ASME Y14.5M.
2. This drawing is subject to change without notice.
3. This dimension does not include mold flash, protrusions, or gate burrs. Mold flash, protrusions, or gate burrs shall not exceed 0.15 mm per side.
4. This dimension does not include interlead flash. Interlead flash shall not exceed 0.25 mm per side.
5. Ref. JEDEC registration MS-013

## EXAMPLE BOARD LAYOUT

**DFM0020A**

**SOIC - 3.55 mm max height**

SMALL OUTLINE PACKAGE

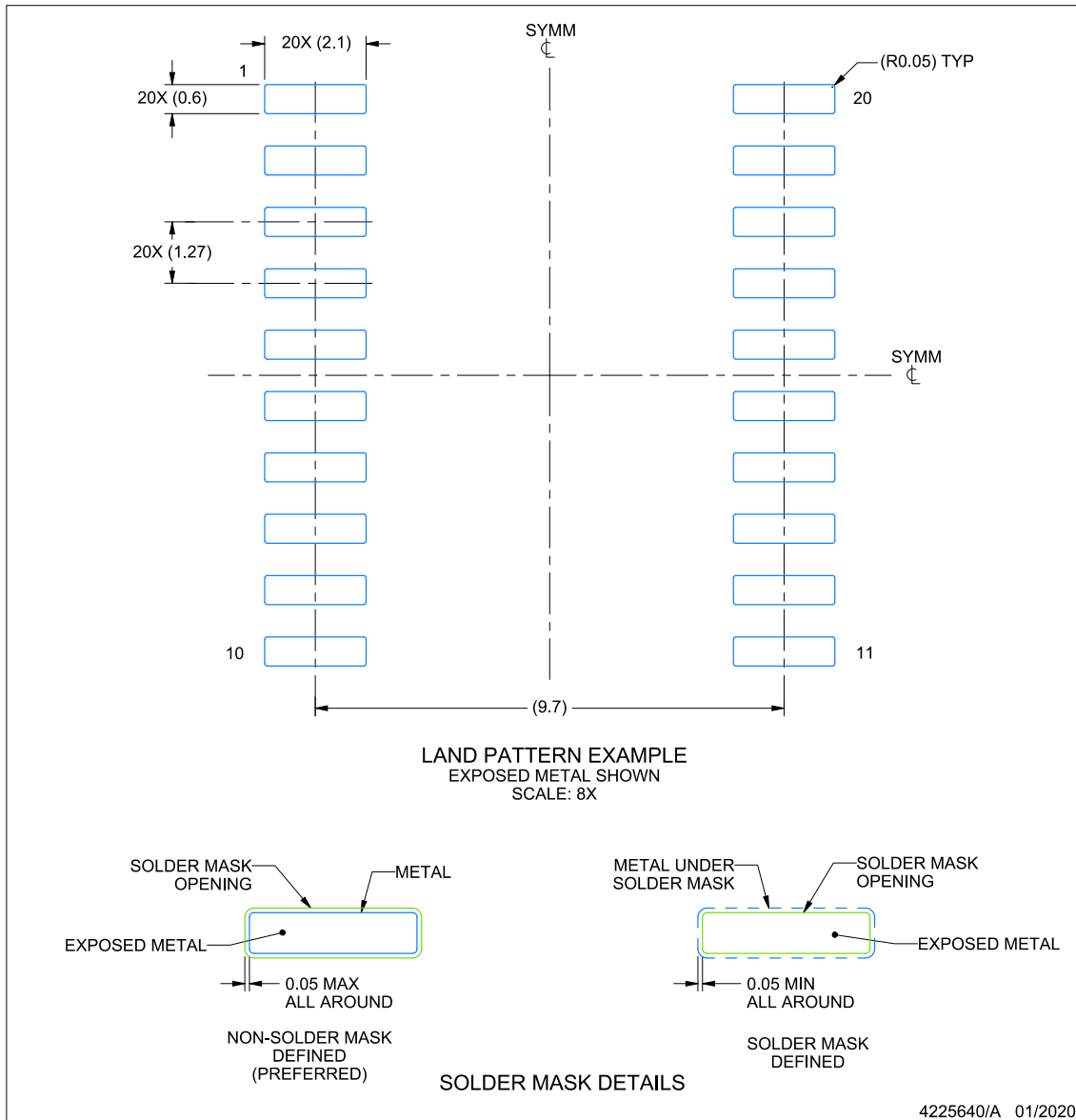

NOTES: (continued)

- Publication IPC-7351 may have alternate designs.
- Solder mask tolerances between and around signal pads can vary based on board fabrication site.

## EXAMPLE STENCIL DESIGN

**DFM0020A**

**SOIC - 3.55 mm max height**

SMALL OUTLINE PACKAGE

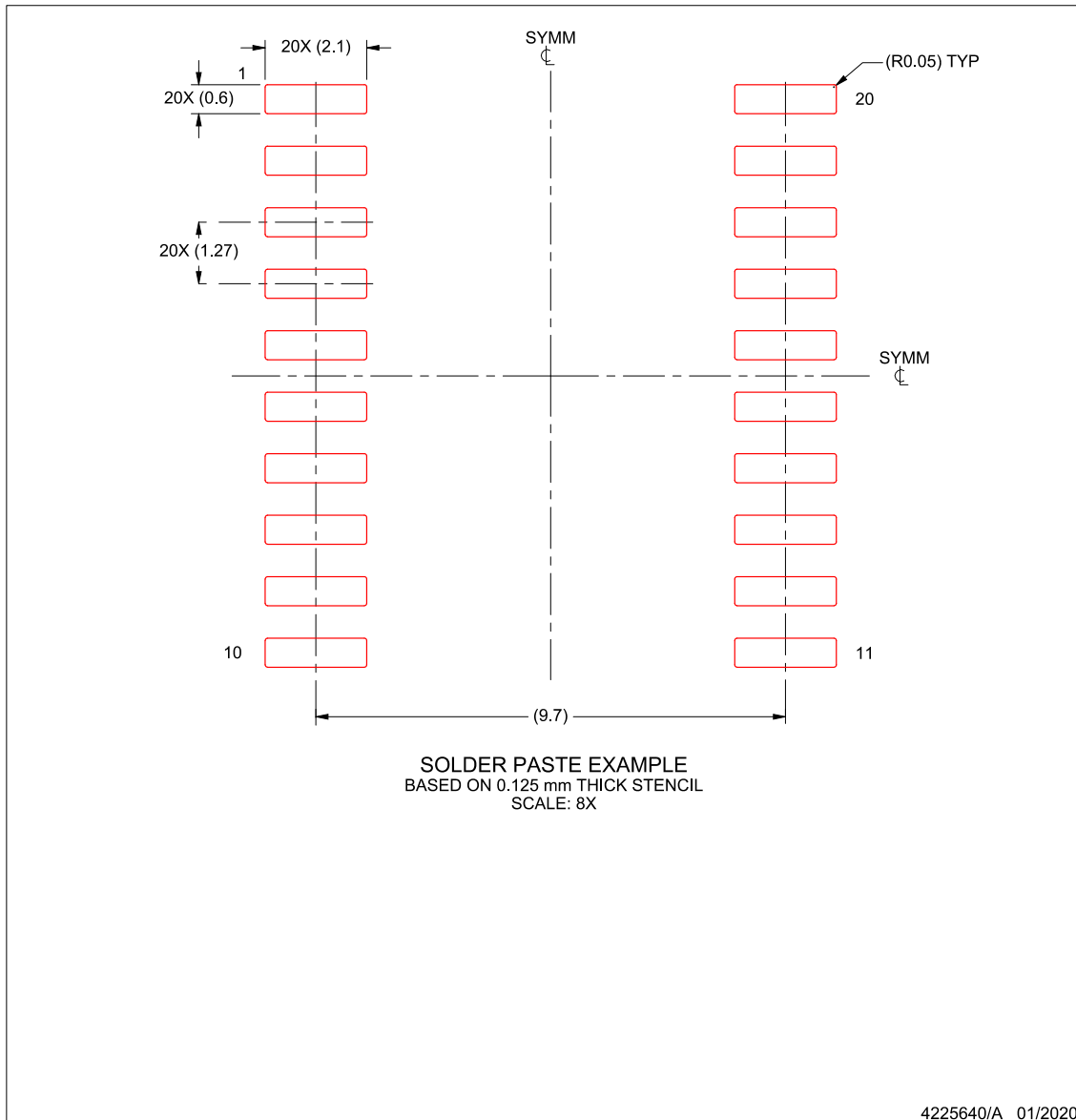

NOTES: (continued)

7. Laser cutting apertures with trapezoidal walls and rounded corners may offer better paste release. IPC-7525 may have alternate design recommendations.
8. Board assembly site may have different recommendations for stencil design.

**PACKAGING INFORMATION**

Orderable Device	Status (1)	Package Type	Package Drawing	Pins	Package Qty	Eco Plan (2)	Lead finish/ Ball material (6)	MSL Peak Temp (3)	Op Temp (°C)	Device Marking (4/5)	Samples
ISOW7721DFMR	ACTIVE	SOIC	DFM	20	850	RoHS & Green	NIPDAU	Level-3-260C-168 HR	-40 to 125	ISOW7721	<a href="#">Samples</a>
ISOW7721FDFMR	ACTIVE	SOIC	DFM	20	850	RoHS & Green	NIPDAU	Level-3-260C-168 HR	-40 to 125	ISOW7721F	<a href="#">Samples</a>

(1) The marketing status values are defined as follows:

**ACTIVE:** Product device recommended for new designs.

**LIFEBUY:** TI has announced that the device will be discontinued, and a lifetime-buy period is in effect.

**NRND:** Not recommended for new designs. Device is in production to support existing customers, but TI does not recommend using this part in a new design.

**PREVIEW:** Device has been announced but is not in production. Samples may or may not be available.

**OBsolete:** TI has discontinued the production of the device.

(2) **RoHS:** TI defines "RoHS" to mean semiconductor products that are compliant with the current EU RoHS requirements for all 10 RoHS substances, including the requirement that RoHS substance do not exceed 0.1% by weight in homogeneous materials. Where designed to be soldered at high temperatures, "RoHS" products are suitable for use in specified lead-free processes. TI may reference these types of products as "Pb-Free".

**RoHS Exempt:** TI defines "RoHS Exempt" to mean products that contain lead but are compliant with EU RoHS pursuant to a specific EU RoHS exemption.

**Green:** TI defines "Green" to mean the content of Chlorine (Cl) and Bromine (Br) based flame retardants meet JS709B low halogen requirements of <=1000ppm threshold. Antimony trioxide based flame retardants must also meet the <=1000ppm threshold requirement.

(3) MSL, Peak Temp. - The Moisture Sensitivity Level rating according to the JEDEC industry standard classifications, and peak solder temperature.

(4) There may be additional marking, which relates to the logo, the lot trace code information, or the environmental category on the device.

(5) Multiple Device Markings will be inside parentheses. Only one Device Marking contained in parentheses and separated by a "~" will appear on a device. If a line is indented then it is a continuation of the previous line and the two combined represent the entire Device Marking for that device.

(6) Lead finish/Ball material - Orderable Devices may have multiple material finish options. Finish options are separated by a vertical ruled line. Lead finish/Ball material values may wrap to two lines if the finish value exceeds the maximum column width.

**Important Information and Disclaimer:**The information provided on this page represents TI's knowledge and belief as of the date that it is provided. TI bases its knowledge and belief on information provided by third parties, and makes no representation or warranty as to the accuracy of such information. Efforts are underway to better integrate information from third parties. TI has taken and continues to take reasonable steps to provide representative and accurate information but may not have conducted destructive testing or chemical analysis on incoming materials and chemicals. TI and TI suppliers consider certain information to be proprietary, and thus CAS numbers and other limited information may not be available for release.

In no event shall TI's liability arising out of such information exceed the total purchase price of the TI part(s) at issue in this document sold by TI to Customer on an annual basis.



## 重要声明和免责声明

TI“按原样”提供技术和可靠性数据（包括数据表）、设计资源（包括参考设计）、应用或其他设计建议、网络工具、安全信息和其他资源，不保证没有瑕疵且不做任何明示或暗示的担保，包括但不限于对适销性、某特定用途方面的适用性或不侵犯任何第三方知识产权的暗示担保。

这些资源可供使用 TI 产品进行设计的熟练开发人员使用。您将自行承担以下全部责任：(1) 针对您的应用选择合适的 TI 产品，(2) 设计、验证并测试您的应用，(3) 确保您的应用满足相应标准以及任何其他功能安全、信息安全、监管或其他要求。

这些资源如有变更，恕不另行通知。TI 授权您仅可将这些资源用于研发本资源所述的 TI 产品的应用。严禁对这些资源进行其他复制或展示。您无权使用任何其他 TI 知识产权或任何第三方知识产权。您应全额赔偿因在这些资源的使用中对 TI 及其代表造成的任何索赔、损害、成本、损失和债务，TI 对此概不负责。

TI 提供的产品受 [TI 的销售条款](#) 或 [ti.com](#) 上其他适用条款/TI 产品随附的其他适用条款的约束。TI 提供这些资源并不会扩展或以其他方式更改 TI 针对 TI 产品发布的适用的担保或担保免责声明。

TI 反对并拒绝您可能提出的任何其他或不同的条款。

邮寄地址：Texas Instruments, Post Office Box 655303, Dallas, Texas 75265

Copyright © 2022，德州仪器 (TI) 公司