

ISO7821x 高性能 8000V_{PK} 增强型双通道数字隔离器

1 特性

- 信令速率：高达 100Mbps
- 宽电源电压范围：2.25V 至 5.5V
- 2.25V 至 5.5V 电平转换
- 宽温度范围：-55°C 至 125°C
- 低功耗，每通道电流典型值为 1.8mA (1Mbps 时)
- 低传播延迟：典型值为 11ns (5V 电源)
- 卓越的 CMTI (下限值)：±100kV/μs
- 优异的电磁兼容性 (EMC)
- 系统级 ESD、EFT 和浪涌抗扰性
- 低辐射
- 隔离栅寿命：> 25 年
- SOIC-16 宽体 (DW) 和超宽体 (DWW) 封装选项
- 安全和监管批准：
 - 8000V_{PK} 增强型隔离，符合 DIN V VDE V 0884-10 (VDE V 0884-10): 2006-12
 - 符合 UL 1577 标准且长达 1 分钟的 5.7kV_{RMS} 隔离
 - CSA 组件验收通知 5A、IEC 60950-1 和 IEC 60601-1 终端设备标准
 - 符合 GB4943.1-2011 的 CQC 认证
 - 符合 EN 61010-1 和 EN 60950-1 标准的 TUV 认证
 - 已完成所有 DW 封装认证；已完成符合 UL、VDE 标准的 DWW 封装认证，并已针对 VDE、CSA 和 CQC 进行规划

2 应用

- 工业自动化
- 电机控制
- 电源
- 光伏逆变器
- 医疗设备
- 混合动力电动汽车

3 说明

ISO7821 是一款高性能双通道数字隔离器，隔离电压高达 8000 V_{PK}。该器件已通过符合 VDE、CSA、CQC 和 TUV 标准的增强型隔离认证。该隔离器以低功耗提供高电磁抗扰度和低辐射，同时隔离 CMOS 或 LVC MOS 数字 I/O。每个隔离通道都有逻辑输入和输出缓冲器，由二氧化硅 (SiO₂) 绝缘栅隔离。ISO7821 具有一个正向通道和一个反向通道。如果输入功率或信号丢失，ISO7821 器件默认输出‘高电平’，ISO7821F 器件默认输出‘低电平’。与隔离式电源一起使用时，这款器件可防止数据总线或者其他电路上的噪音电流进入本地接地和干扰或损坏敏感电路。凭借创新的芯片设计和布线技术，ISO7821 的电磁兼容性得到了显著增强，从而可确保提供系统级 ESD、EFT 和浪涌保护并符合辐射标准。ISO7821 可采用 16 引脚 SOIC 宽体 (DW) 和超宽体 (DWW) 封装。DWW 封装选项带有使能引脚，可用于将各自输出置于高阻抗，适用于多主驱动应用并降低功耗。

器件信息

器件型号	封装	封装尺寸 (标称值)
ISO7821、 ISO7821F	SOIC, DW (16)	10.30mm x 7.50mm
	超宽 SOIC、 DWW (16)	10.30mm x 14.0mm

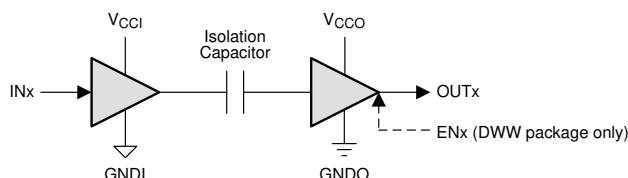

- V_{CCI} 和 GNDI 分别是输入通道的电源和接地连接引脚。
- V_{CCO} 和 GNDO 分别是输出通道的电源和接地连接引脚。

简化版原理图



Table of Contents

1 特性	1	7 Parameter Measurement Information	14
2 应用	1	8 Detailed Description	16
3 说明	1	8.1 Overview.....	16
4 Revision History	2	8.2 Functional Block Diagram.....	16
5 Pin Configuration and Functions	5	8.3 Feature Description.....	17
6 Specifications	6	8.4 Device Functional Modes.....	21
6.1 Absolute Maximum Ratings.....	6	9 Application and Implementation	22
6.2 ESD Ratings.....	6	9.1 Application Information.....	22
6.3 Recommended Operating Conditions.....	6	9.2 Typical Application.....	22
6.4 Thermal Information.....	7	10 Layout	25
6.5 Power Dissipation Characteristics.....	7	10.1 PCB Material.....	25
6.6 Electrical Characteristics, 5 V.....	8	10.2 Layout Guidelines.....	25
6.7 Electrical Characteristics, 3.3 V.....	9	10.3 Layout Example.....	25
6.8 Electrical Characteristics, 2.5 V.....	10	11 Device and Documentation Support	26
6.9 Switching Characteristics, 5 V.....	11	11.1 Documentation Support.....	26
6.10 Switching Characteristics, 3.3 V.....	11	11.2 Trademarks.....	26
6.11 Switching Characteristics, 2.5 V.....	12	12 Mechanical, Packaging, and Orderable Information	26
6.12 Typical Characteristics.....	13		

4 Revision History

注：以前版本的页码可能与当前版本的页码不同

Changes from Revision F (March 2016) to Revision G (July 2022) Page

- 更新了整个文档中的表格、图和交叉参考的编号格式。..... 1

Changes from Revision E (December 2015) to Revision F (March 2016) Page

- 更改了节 1 中的安全及管理批准列表..... 1
- 添加了节 1 “符合 EN 61010-1 和 EN 60950-1 标准的 TUV 认证”..... 1
- 将节 3 的第一段中的文本从“符合 VDE、CSA 和 CQC 认证标准”更改为更改为“符合 VDE、CSA、CQC 和 TUV 认证标准。”..... 1
- Added Note 1 to 表 8-2..... 17
- Added TUV to the 节 8.3.1.1 section and 表 8-4. Deleted Note 1 in Table 4..... 19
- Changed 图 8-5..... 21

Changes from Revision D (July 2015) to Revision E (December 2015) Page

- 将节 1 从 8000V_{PK} V_{IOTM} 和 2121V_{PK} V_{IORM} 增强型更改为：8000V_{PK} 增强型..... 1
- 添加了节 1：已完成 DW 封装认证；已规划 DWW 认证..... 1
- 在说明中添加了文本：和超宽体 (DWW) 封装..... 1
- 添加了封装：在器件信息表中添加了超宽 SOIC、DWW (16)..... 1
- Added the DWW pinout image..... 5
- Added the DWW package to the 节 6.4..... 7
- Changed the MIN value of CMTI in 节 6.6 table From: 70 To: 100 kV/μs, deleted the TYP value of 100 kV/μs . 8
- Added the DW package value to the Supply Current section of the 节 6.6..... 8
- Added the DWW package value to the Supply Current section of the 节 6.6..... 8
- Changed the MIN value of CMTI in 节 6.7 table From: 70 To: 100 kV/μs, deleted the TYP value of 100 kV/μs . 9
- Added the DW package value to the Supply Current section of the 节 6.7..... 9
- Added the DWW package value to the Supply Current section of the 节 6.7..... 9
- Changed the MIN value of CMTI in 节 6.8 table From: 70 To: 100 kV/μs, deleted the TYP value of 100 kV/μs . 10

• Added the DW package value to the Supply Current section of the § 6.8	10
• Added the DWW package value to the Supply Current section of the § 6.8	10
• Added t_{PHZ} , t_{PLZ} , t_{PZH} , and t_{PZL} to § 6.10	11
• Added t_{PHZ} , t_{PLZ} , t_{PZH} , and t_{PZL} to § 6.11	12
• Added 图 7-2	14
• Added the DWW package to 表 8-1	17
• Changed C_{IO} typ value From: 2 To 1 pF in 表 8-1	17
• Added the DWW package to 表 8-2	17
• Changed Parameter information and added the DWW package information in 表 8-3	17
• Added the DWW package information to 表 8-4	19
• added DWW-16 package options to 表 8-5	20
• Changed 表 8-6	21
• Added text to the § 9.1 section: "isolation voltage per UL 1577."	22

Changes from Revision C (May 2015) to Revision D (July 2015) Page

• 在数据表中添加了 ISO7821F 器件.....	1
• 更改了 § 3 , 以便包含 : “ISO7821 器件默认输出为 ‘高电平’ , ISO7821F 器件默认输出为 ‘低电平’ 。 ...	1
• 更改了 图 3-1	1
• Changed t_{PLH} and t_{PHL} From: 5.5 V to 5 V in 图 6-6	13
• Changed 图 7-3	14
• Changed the § 8.2	16
• Changed 表 8-1 title From: <i>IEC Insulation and Safety-Related Specifications for DW-16 Package</i> To: <i>Package Insulation and Safety-Related Specifications</i>	17
• Changed 图 8-3 , Added 图 8-4	20

Changes from Revision B (April 2015) to Revision C (May 2015) Page

• 在整个数据表中 V_{CC1} 和 V_{CC2} 更改为 : V_{CC1} 和 V_{CC0} , $GND1$ 和 $GND2$ 更改为 : $GND1$ 和 $GND0$, 并在 图 3-1 中添加了注释 1 和 2.....	1
• Changed the MIN value of CMTI in § 6.6 table From: 50 To: 70 kV/ μ s	8
• Changed the MIN value of CMTI in § 6.7 table From: 50 To: 70 kV/ μ s	9
• Changed the MIN value of CMTI in § 6.8 table From: 50 To: 70 kV/ μ s	10
• Added sentence "If the EN pin is available and low then the output goes to high impedance." to the § 8.1 section	16
• Changed the § 8.2 to include the EN pin on the Receiver side.....	16
• Changed the Installation classification of the 表 8-3 to include DW package information.....	17
• Changed "ISO782W functional modes" To: "ISO7821DW functional modes" in § 8.4	21
• Changed 表 8-6 title From: "Functional Table" To: "ISO7821DW Function Table".....	21
• Added the § 8.4.1 section	21
• Changed device number ISO7821 To: ISO7821DW in 图 9-2	23

Changes from Revision A (December 2014) to Revision B (April 2015) Page

• 将文档标题从 “通道数字隔离器” 更改为 : “通道 1/1 数字隔离器”	1
• 添加了 § 1 : 2.25V 至 5.5V 电平转换.....	1
• 更改了 § 1 中的安全及管理批准列表.....	1
• 将 § 3 中的文本从 “该器件正在接受 VDE 和 CSA 的增强型隔离认证审核。更改为 “该器件已通过 VDE、CSA 和 CQC 的增强型隔离认证。”	1
• Added Note (3) to the § 6.1 table.....	6
• Changed From: V_{CCX} To: V_{CC0} In I_{OH} and I_{OL} of the § 6.3 table	6
• Changed From: V_{CCX} To: V_{CC1} In V_{IH} and V_{IL} of the § 6.3 table	6
• Changed Note (1) of the § 6.3 table	6
• Changed From: V_{CCX} To: V_{CC0} In V_{OH} of the § 6.6 table	8

• Changed From: V_{CCX} To: V_{CCO} In $V_{I(HYS)}$ of the 节 6.6 table	8
• Changed From: V_{CCX} To: V_{CCI} In I_{IH} of the 节 6.6 table	8
• Changed From: V_{CCX} To: V_{CCI} In CMTI of the 节 6.6 table	8
• Changed From: V_{CCX} To: V_{CCI} In Supply Current, DC Signal of the 节 6.6 table.....	8
• Changed Note (1) of the 节 6.6 table	8
• Changed From: V_{CCX} To: V_{CCO} In V_{OH} of the 节 6.7 table	9
• Changed From: V_{CCX} To: V_{CCO} In $V_{I(HYS)}$ of the 节 6.7 table	9
• Changed From: V_{CCX} To: V_{CCI} In I_{IH} of the 节 6.7 table.....	9
• Changed From: V_{CCX} To: V_{CCI} In CMTI of the 节 6.7 table	9
• Changed From: V_{CCX} To: V_{CCI} In Supply Current, DC Signal of the 节 6.7 table	9
• Changed Note (1) of the 节 6.7 table	9
• Changed From: V_{CCX} To: V_{CCO} In V_{OH} of the 节 6.8 table	10
• Changed From: V_{CCX} To: V_{CCI} In I_{IH} of the 节 6.8 table	10
• Changed From: V_{CCX} To: V_{CCI} In Supply Current, DC Signal of the 节 6.8 table	10
• Changed Note (1) of the 节 6.8 table	10
• Changed 图 7-1	14
• Changed From: V_{CC1} To: V_{CCI} in 图 7-3	14
• Changed 图 7-4	14
• Changed the Test Condition of CTI in 表 8-1	17
• Changed the MIN value of CTI From" > 600 V To: 600 V.....	17
• Changed 表 8-2 title From: <i>DIN V VDE 0884-10 (VDE V 0884-10) and UL 1577 Insulation Characteristics</i> To: <i>Added the DWW package to</i>	17
• Changed 表 8-2	17
• Changed columns VDE and CSA to 表 8-4	19
• Changed title From: <i>IEC Safety Limiting Values</i> To: 节 8.3.1.2	20
• Changed the table in 节 8.3.1.2, added I_S DW-16 package options.....	20
• Changed 图 8-3	20
• Deleted INPUT-SIDE and OUTPUT-SIDE from columns 1 and 2 of 表 8-6	21
• Changed Note (1) of 表 8-6	21
• Changed the 节 9.1 section.....	22
• Changed the 节 9.2 section and 图 9-1	22
• Added text and 图 9-2 to the 节 9.2.2 section	23

Changes from Revision * (November 2014) to Revision A (December 2014)
Page

• 将仅包含第 1 页和引脚分配部分的产品预发布更改为：完整数据表.....	1
• Added Note: "This coupler..." to the 节 8.3.1 section	17

5 Pin Configuration and Functions



图 5-1. DW Package 16-Pin (SOIC) Top View



图 5-2. DWW Package 16-Pin (SOIC) Top View

表 5-1. Pin Functions

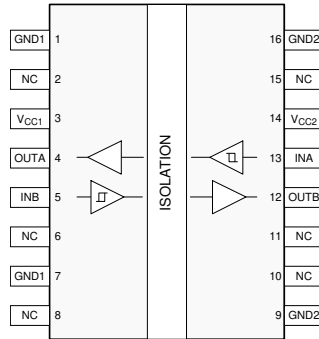
NAME	PIN		I/O	DESCRIPTION
	NO. DW	NO. DWW		
GND1	1, 7	2, 8	-	Ground connection for V_{CC1}
GND2	9, 16	9, 15	-	Ground connection for V_{CC2}
INA	13	12	I	Input, channel A
INB	5	6	I	Input, channel B
NC	2, 6, 8, 10, 11, 15	3, 7, 10, 14	-	Not connected
OUTA	4	5	O	Output, channel A
OUTB	12	11	O	Output, channel B
V_{CC1}	3	1	-	Power supply, V_{CC1}
V_{CC2}	14	16	-	Power supply, V_{CC2}
EN1	-	4	I	Output enable 1. Output pins on side 1 are enabled when EN1 is high or open and in high-impedance state when EN1 is low.
EN2	-	13	I	Output enable 2. Output pins on side 2 are enabled when EN2 is high or open and in high-impedance state when EN2 is low.

6 Specifications

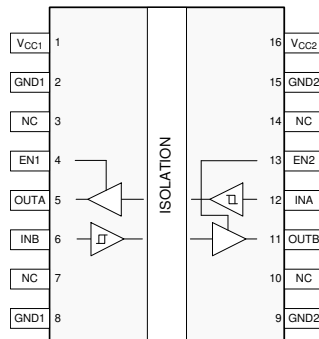
6.1 Absolute Maximum Ratings

		MIN	MAX	UNIT
Supply voltage ⁽¹⁾	V_{CC1}, V_{CC2}	-0.5	6	V
Voltage	INx, OUTx	-0.5	$V_{CC} + 0.5^{(2)}$	V
Output Current	I_O	-15	15	mA
Surge Immunity			12.8	kV
Storage temperature, T_{stg}		-65	150	°C

- (1) All voltage values except differential I/O bus voltages are with respect to the local ground terminal (GND1 or GND2) and are peak voltage values.
- (2) Maximum voltage must not exceed 6 V.

6.2 ESD Ratings

			VALUE	UNIT
V_{ESD}	Electrostatic discharge	Human body model (HBM), per ANSI/ESDA/JEDEC JS-001, all pins ⁽¹⁾	±6000	V
		Charged device model (CDM), per JEDEC specification JESD22-C101, all pins ⁽²⁾	±1500	V

- (1) JEDEC document JEP155 states that 500-V HBM allows safe manufacturing with a standard ESD control process.
- (2) JEDEC document JEP157 states that 250-V CDM allows safe manufacturing with a standard ESD control process.

6.3 Recommended Operating Conditions

		MIN	TYP	MAX	UNIT
V_{CC1}, V_{CC2}	Supply voltage	2.25		5.5	V
I_{OH}	High-level output current	$V_{CCO}^{(2)} = 5\text{ V}$		-4	mA
		$V_{CCO} = 3.3\text{ V}$		-2	
		$V_{CCO} = 2.5\text{ V}$		-1	
I_{OL}	Low-level output current	$V_{CCO} = 5\text{ V}$		4	mA
		$V_{CCO} = 3.3\text{ V}$		2	
		$V_{CCO} = 2.5\text{ V}$		1	
V_{IH}	High-level input voltage	$0.7 \times V_{CCI}^{(2)}$		V_{CCI}	V
V_{IL}	Low-level input voltage	0		$0.3 \times V_{CCI}$	V
DR	Signaling rate	0		100	Mbps
T_J	Junction temperature ⁽¹⁾	-55		150	°C
T_A	Ambient temperature	-55	25	125	°C

- (1) To maintain the recommended operating conditions for T_J , see the [Thermal Information](#) table.
- (2) V_{CCI} = Input-side V_{CC} ; V_{CCO} = Output-side V_{CC} .

6.4 Thermal Information

THERMAL METRIC ⁽¹⁾		ISO7821		UNIT
		DW (SOIC)	DWW (SOIC)	
		16 PINS	16-PINS	
$R_{\theta JA}$	Junction-to-ambient thermal resistance	84.7	84.7	°C/W
$R_{\theta JC(top)}$	Junction-to-case(top) thermal resistance	47.3	46.0	°C/W
$R_{\theta JB}$	Junction-to-board thermal resistance	49.4	54.5	°C/W
ψ_{JT}	Junction-to-top characterization parameter	19.1	18.5	°C/W
ψ_{JB}	Junction-to-board characterization parameter	48.8	53.8	°C/W
$R_{\theta JC(bottom)}$	Junction-to-case(bottom) thermal resistance	n/a	n/a	°C/W

(1) For more information about traditional and new thermal metrics, see the [Semiconductor and IC Package Thermal Metrics](#) application report.

6.5 Power Dissipation Characteristics

		VALUE	UNIT
P_D	Maximum power dissipation by ISO7821 x	100	mW
P_{D1}	Maximum power dissipation by side-1 of ISO7821 x	50	
P_{D2}	Maximum power dissipation by side-2 of ISO7821 x	50	

$V_{CC1} = V_{CC2} = 5.5\text{ V}$, $T_J = 150^\circ\text{C}$,
 $C_L = 15\text{ pF}$, input a 50 MHz 50% duty cycle square wave

6.6 Electrical Characteristics, 5 V

$V_{CC1} = V_{CC2} = 5\text{ V} \pm 10\%$ (over recommended operating conditions unless otherwise noted)

PARAMETER		TEST CONDITIONS	MIN	TYP	MAX	UNIT
V_{OH}	High-level output voltage	$I_{OH} = -4\text{ mA}$; see 图 7-1	$V_{CCO}^{(1)} - 0.4$	$V_{CCO} - 0.2$		V
V_{OL}	Low-level output voltage	$I_{OL} = 4\text{ mA}$; see 图 7-1		0.2	0.4	V
$V_{I(HYS)}$	Input threshold voltage hysteresis		$0.1 \times V_{CCO}^{(1)}$			V
I_{IH}	High-level input current	$V_I = V_{CCI}^{(1)}$ at INx or ENx			10	μA
I_{IL}	Low-level input current	$V_I = 0\text{ V}$ at INx or ENx	-10			
CMTI	Common-mode transient immunity	$V_I = V_{CCI}$ or 0 V; see 图 7-4	100			kV/ μs
Supply Current - ISO7821DW and ISO7821FDW						
I_{CC1}, I_{CC2}	DC Signal	$V_I = 0\text{ V}$ (ISO7821F), $V_I = V_{CCI}^{(1)}$ (ISO7821)		1.2	1.7	mA
I_{CC1}, I_{CC2}	DC Signal	$V_I = V_{CCI}^{(1)}$ (ISO7821F), $V_I = 0\text{ V}$ (ISO7821)		2.4	3.4	mA
I_{CC1}, I_{CC2}	1 Mbps	All channels switching with square wave clock input; $C_L = 15\text{ pF}$		1.8	2.6	mA
I_{CC1}, I_{CC2}	10 Mbps			2.4	3.2	mA
I_{CC1}, I_{CC2}	100 Mbps			7.5	9.3	mA
Supply Current - ISO7821DWW and ISO7821FDWW						
I_{CC1}, I_{CC2}	Disable	$EN1 = EN2 = 0\text{V}$, $V_I = 0\text{ V}$ (ISO7821F), $V_I = V_{CCI}^{(1)}$ (ISO7821)		0.7	1.1	mA
I_{CC1}, I_{CC2}	Disable	$EN1 = EN2 = 0\text{V}$, $V_I = V_{CCI}^{(1)}$ (ISO7821F), $V_I = 0\text{ V}$ (ISO7821)		1.8	2.9	mA
I_{CC1}, I_{CC2}	DC Signal	$V_I = 0\text{ V}$ (ISO7821F), $V_I = V_{CCI}^{(1)}$ (ISO7821)		1.2	1.7	mA
I_{CC1}, I_{CC2}	DC Signal	$V_I = V_{CCI}^{(1)}$ (ISO7821F), $V_I = 0\text{ V}$ (ISO7821)		2.4	3.5	mA
I_{CC1}, I_{CC2}	1 Mbps	All channels switching with square wave clock input; $C_L = 15\text{ pF}$		1.9	2.7	mA
I_{CC1}, I_{CC2}	10 Mbps			2.5	3.2	mA
I_{CC1}, I_{CC2}	100 Mbps			7.7	9.3	mA

(1) V_{CCI} = Input-side V_{CC} ; V_{CCO} = Output-side V_{CC} .

6.7 Electrical Characteristics, 3.3 V

$V_{CC1} = V_{CC2} = 3.3 \text{ V} \pm 10\%$ (over recommended operating conditions unless otherwise noted)

PARAMETER		TEST CONDITIONS	MIN	TYP	MAX	UNIT
V_{OH}	High-level output voltage	$I_{OH} = -2 \text{ mA}$; see 图 7-1	$V_{CCO}^{(1)} - 0.4$	$V_{CCO} - 0.2$		V
V_{OL}	Low-level output voltage	$I_{OL} = 2 \text{ mA}$; see 图 7-1		0.2	0.4	V
$V_{I(HYS)}$	Input threshold voltage hysteresis		$0.1 \times V_{CCO}$			V
I_{IH}	High-level input current	$V_I = V_{CCI}^{(1)}$ at INx or ENx			10	μA
I_{IL}	Low-level input current	$V_{IL} = 0 \text{ V}$ at INx or ENx	-10			
CMTI	Common-mode transient immunity	$V_I = V_{CCI}$ or 0 V; see 图 7-4	100			kV/ μs
Supply Current - ISO7821DW and ISO7821FDW						
I_{CC1}, I_{CC2}	DC Signal	$V_I = 0 \text{ V}$ (ISO7821F), $V_I = V_{CCI}^{(1)}$ (ISO7821)		1.2	1.7	mA
I_{CC1}, I_{CC2}	DC Signal	$V_I = V_{CCI}^{(1)}$ (ISO7821F), $V_I = 0 \text{ V}$ (ISO7821)		2.4	3.4	mA
I_{CC1}, I_{CC2}	1 Mbps	All channels switching with square wave clock input; $C_L = 15 \text{ pF}$		1.8	2.6	mA
I_{CC1}, I_{CC2}	10 Mbps			2.2	3	mA
I_{CC1}, I_{CC2}	100 Mbps			5.8	7.1	mA
Supply Current - ISO7821DWW and ISO7821FDWW						
I_{CC1}, I_{CC2}	Disable	$EN1 = EN2 = 0 \text{ V}$, $V_I = 0 \text{ V}$ (ISO7821F), $V_I = V_{CCI}^{(1)}$ (ISO7821)		0.7	1.1	mA
I_{CC1}, I_{CC2}	Disable	$EN1 = EN2 = 0 \text{ V}$, $V_I = V_{CCI}^{(1)}$ (ISO7821F), $V_I = 0 \text{ V}$ (ISO7821)		1.8	2.9	mA
I_{CC1}, I_{CC2}	DC Signal	$V_I = 0 \text{ V}$ (ISO7821F), $V_I = V_{CCI}^{(1)}$ (ISO7821)		1.2	1.7	mA
I_{CC1}, I_{CC2}	DC Signal	$V_I = V_{CCI}^{(1)}$ (ISO7821F), $V_I = 0 \text{ V}$ (ISO7821)		2.4	3.5	mA
I_{CC1}, I_{CC2}	1 Mbps	All channels switching with square wave clock input; $C_L = 15 \text{ pF}$		1.9	2.6	mA
I_{CC1}, I_{CC2}	10 Mbps			2.3	3	mA
I_{CC1}, I_{CC2}	100 Mbps			5.9	7.1	mA

(1) V_{CCI} = Input-side V_{CC} ; V_{CCO} = Output-side V_{CC} .

6.8 Electrical Characteristics, 2.5 V

$V_{CC1} = V_{CC2} = 2.5 \text{ V} \pm 10\%$ (over recommended operating conditions unless otherwise noted)

PARAMETER		TEST CONDITIONS	MIN	TYP	MAX	UNIT
V_{OH}	High-level output voltage	$I_{OH} = -1 \text{ mA}$; see 图 7-1	$V_{CCO}^{(1)} - 0.4$	$V_{CCO} - 0.2$		V
V_{OL}	Low-level output voltage	$I_{OL} = 1 \text{ mA}$; see 图 7-1		0.2	0.4	V
$V_{I(HYS)}$	Input threshold voltage hysteresis		$0.1 \times V_{CCO}$			V
I_{IH}	High-level input current	$V_I = V_{CCI}^{(1)}$ at INx or ENx			10	μA
I_{IL}	Low-level input current	$V_I = 0 \text{ V}$ at INx or ENx	-10			
CMTI	Common-mode transient immunity	$V_I = V_{CCI}$ or 0 V; see 图 7-4	100			kV/ μs
Supply Current - ISO7821DW and ISO7821FDW						
I_{CC1}, I_{CC2}	DC Signal	$V_I = 0 \text{ V}$ (ISO7821F), $V_I = V_{CCI}^{(1)}$ (ISO7821)		1.2	1.7	mA
I_{CC1}, I_{CC2}	DC Signal	$V_I = V_{CCI}^{(1)}$ (ISO7821F), $V_I = 0 \text{ V}$ (ISO7821)		2.4	3.4	mA
I_{CC1}, I_{CC2}	1 Mbps	All channels switching with square wave clock input; $C_L = 15 \text{ pF}$		1.8	2.6	mA
I_{CC1}, I_{CC2}	10 Mbps			2.1	2.8	mA
I_{CC1}, I_{CC2}	100 Mbps			4.9	5.9	mA
Supply Current - ISO7821DWW and ISO7821FDWW						
I_{CC1}, I_{CC2}	Disable	$EN1 = EN2 = 0 \text{ V}$, $V_I = 0 \text{ V}$ (ISO7821F), $V_I = V_{CCI}^{(1)}$ (ISO7821)		0.7	1.1	mA
I_{CC1}, I_{CC2}	Disable	$EN1 = EN2 = 0 \text{ V}$, $V_I = V_{CCI}^{(1)}$ (ISO7821F), $V_I = 0 \text{ V}$ (ISO7821)		1.8	2.9	mA
I_{CC1}, I_{CC2}	DC Signal	$V_I = 0 \text{ V}$ (ISO7821F), $V_I = V_{CCI}^{(1)}$ (ISO7821)		1.2	1.7	mA
I_{CC1}, I_{CC2}	DC Signal	$V_I = V_{CCI}^{(1)}$ (ISO7821F), $V_I = 0 \text{ V}$ (ISO7821)		2.4	3.5	mA
I_{CC1}, I_{CC2}	1 Mbps	All channels switching with square wave clock input; $C_L = 15 \text{ pF}$		1.9	2.6	mA
I_{CC1}, I_{CC2}	10 Mbps			2.2	2.9	mA
I_{CC1}, I_{CC2}	100 Mbps			5	6	mA

(1) V_{CCI} = Input-side V_{CC} ; V_{CCO} = Output-side V_{CC} .

6.9 Switching Characteristics, 5 V

 $V_{CC1} = V_{CC2} = 5\text{ V} \pm 10\%$ (over recommended operating conditions unless otherwise noted)

PARAMETER		TEST CONDITIONS	MIN	TYP	MAX	UNIT
t_{PLH}, t_{PHL}	Propagation delay time	See 图 7-1	6	10.7	16	ns
PWD ⁽¹⁾	Pulse width distortion $ t_{PHL} - t_{PLH} $					
$t_{sk(pp)}$ ⁽²⁾	Part-to-part skew time				4.5	ns
t_r	Output signal rise time	See 图 7-1		2.4	3.9	ns
t_f	Output signal fall time					
t_{PHZ}	Disable propagation delay, high-to-high impedance output for ISO7821DWW and ISO7821FDWW	See 图 7-2		12	20	ns
t_{PLZ}	Disable propagation delay, low-to-high impedance output for ISO7821DWW and ISO7821FDWW					
t_{PZH}	Enable propagation delay, high impedance-to-high output for ISO7821DWW					
	Enable propagation delay, high impedance-to-high output for ISO7821FDWW					
t_{PZL}	Enable propagation delay, high impedance-to-low output for ISO7821DWW					
	Enable propagation delay, high impedance-to-low output for ISO7821FDWW					
t_{fs}	Default output delay time from input power loss	Measured from the time V_{CC} goes below 1.7 V. See 图 7-3	0.2	9	μs	
t_{ie}	Time interval error	$2^{16} - 1$ PRBS data at 100 Mbps	1		ns	

(1) Also known as Pulse Skew.

(2) $t_{sk(pp)}$ is the magnitude of the difference in propagation delay times between any terminals of different devices switching in the same direction while operating at identical supply voltages, temperature, input signals and loads.

6.10 Switching Characteristics, 3.3 V

 $V_{CC1} = V_{CC2} = 3.3\text{ V} \pm 10\%$ (over recommended operating conditions unless otherwise noted)

PARAMETER		TEST CONDITIONS	MIN	TYP	MAX	UNIT
t_{PLH}, t_{PHL}	Propagation delay time	See 图 7-1	6	10.8	16	ns
PWD ⁽¹⁾	Pulse width distortion $ t_{PHL} - t_{PLH} $					
$t_{sk(pp)}$ ⁽²⁾	Part-to-part skew time				4.5	ns
t_r	Output signal rise time	See 图 7-1		1.3	3	ns
t_f	Output signal fall time					
t_{PHZ}	Disable propagation delay, high-to-high impedance output for ISO7821DWW and ISO7821FDWW	See 图 7-2		17	32	ns
t_{PLZ}	Disable propagation delay, low-to-high impedance output for ISO7821DWW and ISO7821FDWW					
t_{PZH}	Enable propagation delay, high impedance-to-high output for ISO7821DWW					
	Enable propagation delay, high impedance-to-high output for ISO7821FDWW					
t_{PZL}	Enable propagation delay, high impedance-to-low output for ISO7821DWW					
	Enable propagation delay, high impedance-to-low output for ISO7821FDWW					
t_{fs}	Default output delay time from input power loss	Measured from the time V_{CC} goes below 1.7 V. See 图 7-3	0.2	9	μs	
t_{ie}	Time interval error	$2^{16} - 1$ PRBS data at 100 Mbps	1		ns	

(1) Also known as Pulse Skew.

(2) $t_{sk(pp)}$ is the magnitude of the difference in propagation delay times between any terminals of different devices switching in the same direction while operating at identical supply voltages, temperature, input signals and loads.

6.11 Switching Characteristics, 2.5 V

$V_{CC1} = V_{CC2} = 2.5 \text{ V} \pm 10\%$ (over recommended operating conditions unless otherwise noted)

PARAMETER		TEST CONDITIONS	MIN	TYP	MAX	UNIT
t_{PLH}, t_{PHL}	Propagation delay time	See 图 7-1	7.5	11.7	17.5	ns
PWD ⁽¹⁾	Pulse width distortion $ t_{PHL} - t_{PLH} $		0.7	4.7		
$t_{sk(pp)}$ ⁽²⁾	Part-to-part skew time			4.5		
t_r	Output signal rise time	See 图 7-1		1.8	3.5	ns
t_f	Output signal fall time			1.8	3.5	
t_{PHZ}	Disable propagation delay, high-to-high impedance output for ISO7821DWW and ISO7821FDWW	See 图 7-2		22	45	ns
t_{PLZ}	Disable propagation delay, low-to-high impedance output for ISO7821DWW and ISO7821FDWW			22	45	ns
t_{PZH}	Enable propagation delay, high impedance-to-high output for ISO7821DWW			18	45	ns
	Enable propagation delay, high impedance-to-high output for ISO7821FDWW			2	2.5	μs
t_{PZL}	Enable propagation delay, high impedance-to-low output for ISO7821DWW			2	2.5	μs
	Enable propagation delay, high impedance-to-low output for ISO7821FDWW			18	45	ns
t_{fs}	Default output delay time from input power loss	Measured from the time V_{CC} goes below 1.7 V. See 图 7-3		0.2	9	μs
t_{ie}	Time interval error	$2^{16} - 1$ PRBS data at 100 Mbps		1		ns

(1) Also known as Pulse Skew.

(2) $t_{sk(pp)}$ is the magnitude of the difference in propagation delay times between any terminals of different devices switching in the same direction while operating at identical supply voltages, temperature, input signals and loads.

6.12 Typical Characteristics



图 6-1. Supply Current vs Data Rate (with 15 pF Load)



图 6-2. Supply Current vs Data Rate (with No Load)

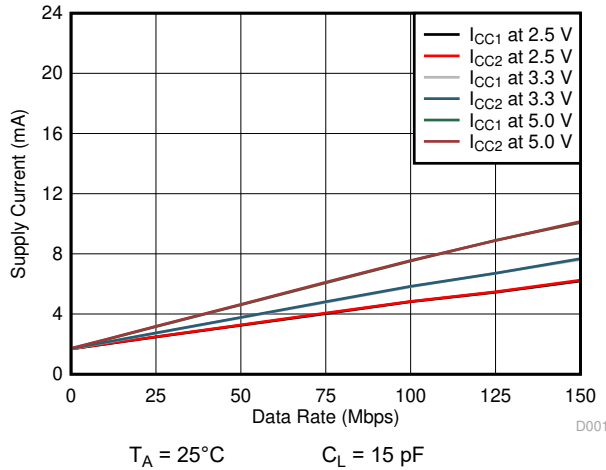

图 6-3. High-Level Output Voltage vs High-level Output Current

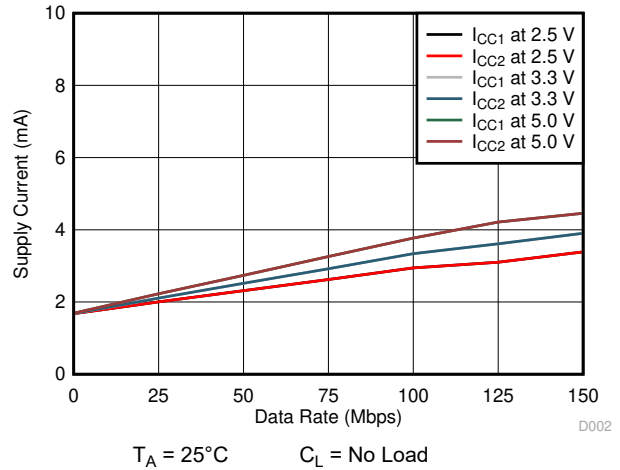

图 6-4. Low-Level Output Voltage vs Low-Level Output Current

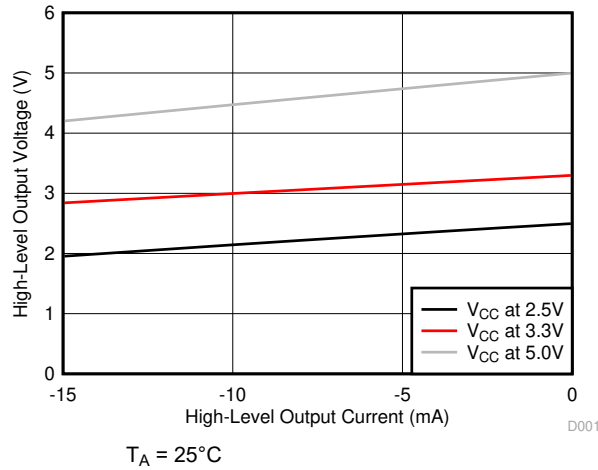

图 6-5. Power Supply Undervoltage Threshold vs Free-Air Temperature

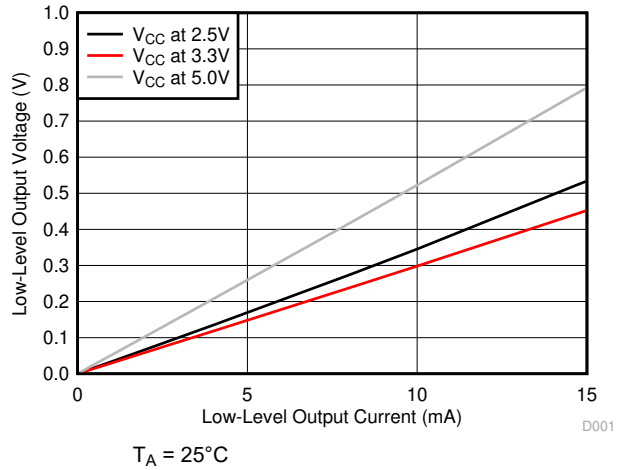

图 6-6. Propagation Delay Time vs Free-Air Temperature

7 Parameter Measurement Information

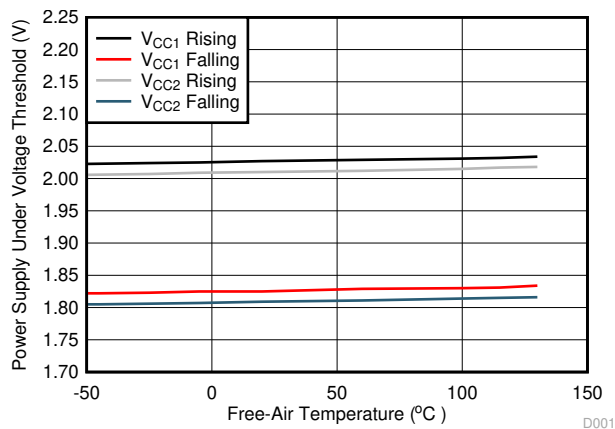

- A. The input pulse is supplied by a generator having the following characteristics: $PRR \leq 50 \text{ kHz}$, 50% duty cycle, $t_r \leq 3 \text{ ns}$, $t_f \leq 3 \text{ ns}$, $Z_O = 50 \Omega$. At the input, 50Ω resistor is required to terminate Input Generator signal. It is not needed in actual application.
- B. $C_L = 15 \text{ pF}$ and includes instrumentation and fixture capacitance within $\pm 20\%$.

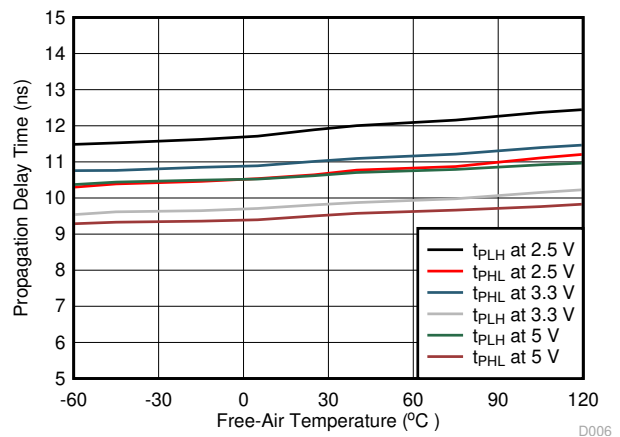
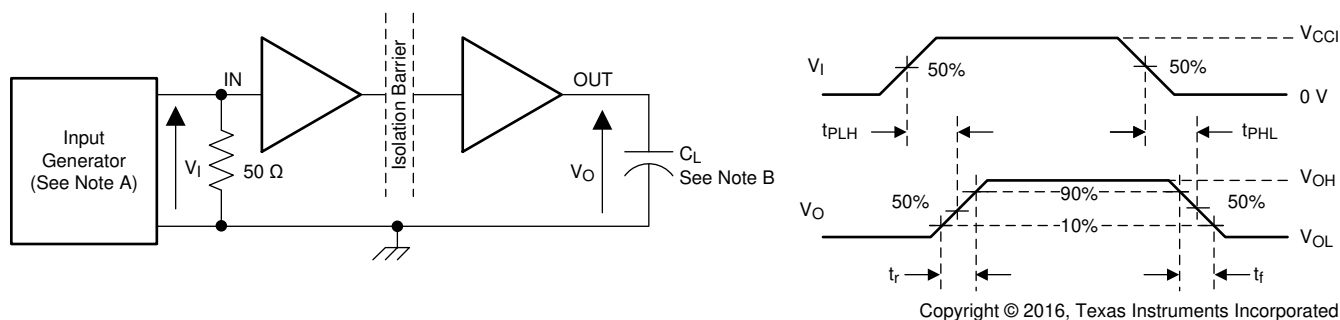
图 7-1. Switching Characteristics Test Circuit and Voltage Waveforms

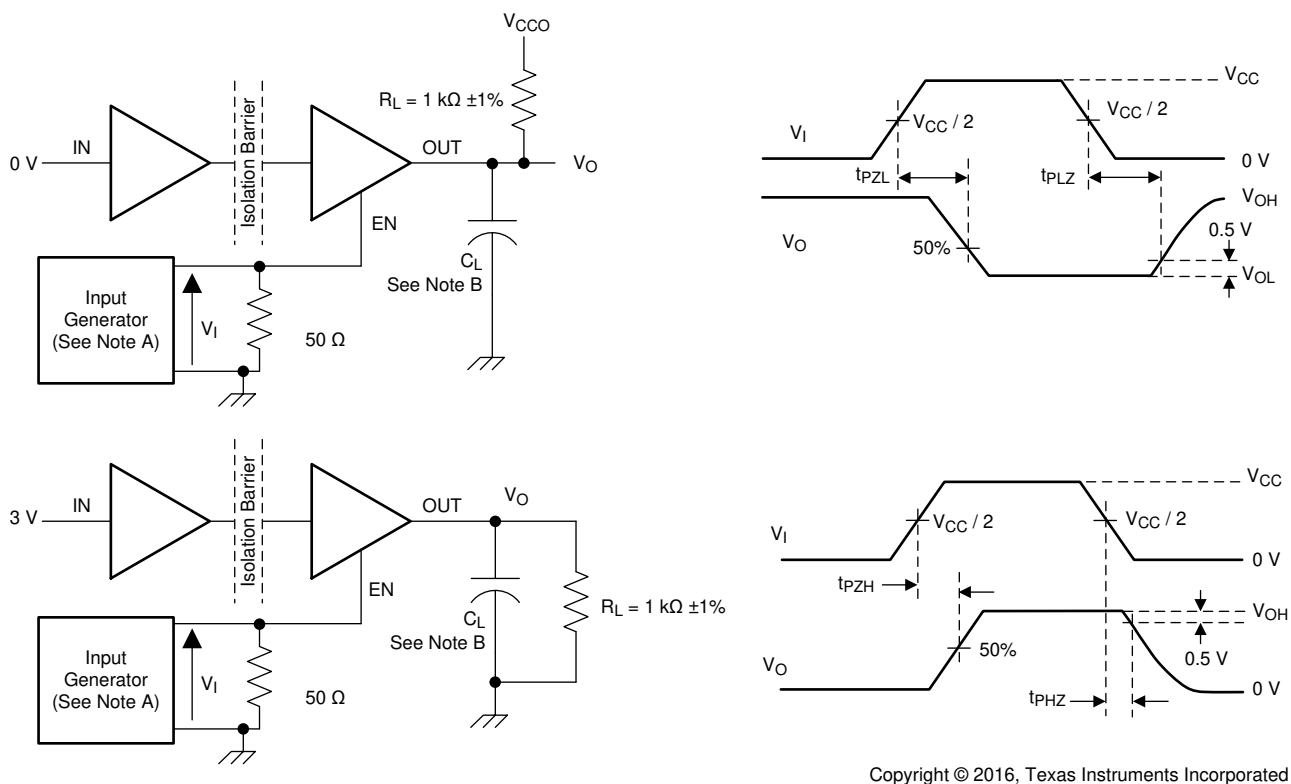

- A. The input pulse is supplied by a generator having the following characteristics: $PRR \leq 10 \text{ kHz}$, 50% duty cycle, $t_r \leq 3 \text{ ns}$, $t_f \leq 3 \text{ ns}$, $Z_O = 50 \Omega$.
- B. $C_L = 15 \text{ pF}$ and includes instrumentation and fixture capacitance within $\pm 20\%$.

图 7-2. Enable/Disable Propagation Delay Time Test Circuit and Waveform

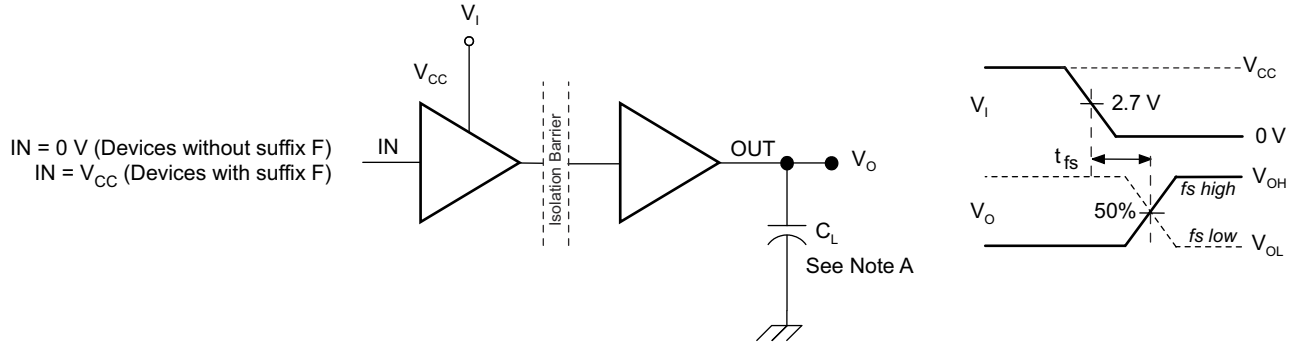

A. $C_L = 15$ pF and includes instrumentation and fixture capacitance within $\pm 20\%$.

图 7-3. Default Output Delay Time Test Circuit and Voltage Waveforms

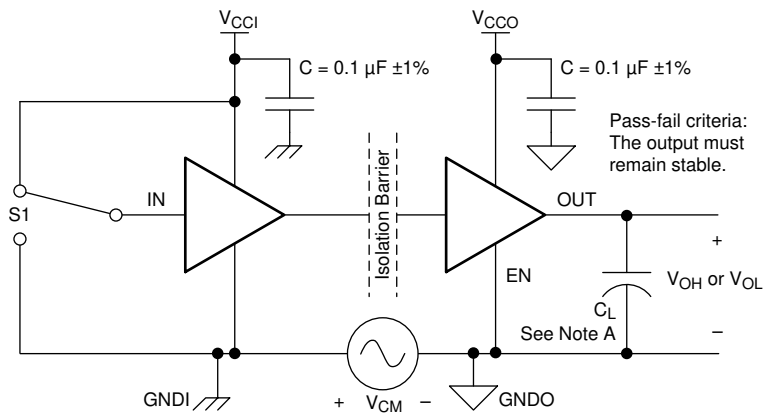

A. $C_L = 15$ pF and includes instrumentation and fixture capacitance within $\pm 20\%$.

图 7-4. Common-Mode Transient Immunity Test Circuit

8 Detailed Description

8.1 Overview

ISO7821 employs an ON-OFF Keying (OOK) modulation scheme to transmit the digital data across a silicon dioxide based isolation barrier. The transmitter sends a high frequency carrier across the barrier to represent one digital state and sends no signal to represent the other digital state. The receiver demodulates the signal after advanced signal conditioning and produces the output through a buffer stage. These devices also incorporate advanced circuit techniques to maximize the CMTI performance and minimize the radiated emissions due to the high frequency carrier and IO buffer switching. The conceptual block diagram of a digital capacitive isolator, [Figure 8-1](#), shows a functional block diagram of a typical channel.

8.2 Functional Block Diagram

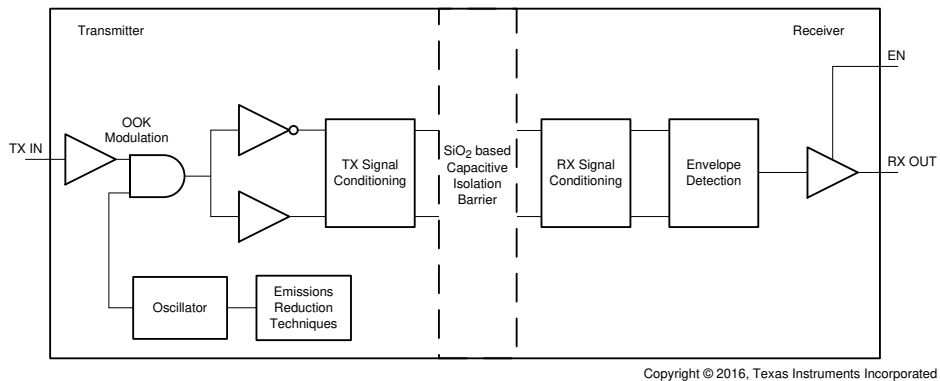

Figure 8-1. Conceptual Block Diagram of a Digital Capacitive Isolator

Also a conceptual detail of how the ON/OFF Keying scheme works is shown in [Figure 8-2](#).

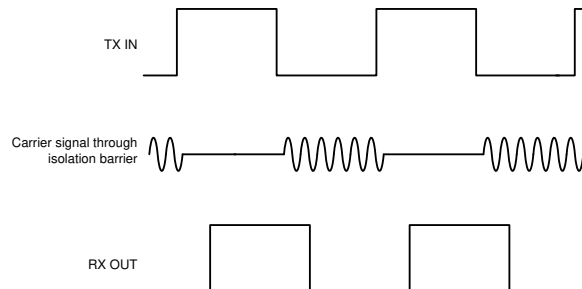

Figure 8-2. On-Off Keying (OOK) Based Modulation Scheme

8.3 Feature Description

ISO7821 is available in two channel configurations and default output state options to enable a variety of application uses.

PRODUCT	CHANNEL DIRECTION	RATED ISOLATION	MAX DATA RATE	DEFAULT OUTPUT
ISO7821	1 Forward, 1 Reverse	5700 V _{RMS} / 8000 V _{PK} ⁽¹⁾	100 Mbps	High
ISO7821F	1 Forward, 1 Reverse	5700 V _{RMS} / 8000 V _{PK} ⁽¹⁾	100 Mbps	Low

(1) See the [Regulatory Information](#) section for detailed isolation ratings.

8.3.1 High Voltage Feature Description

备注

This coupler is suitable for 'safe electrical insulation' only within the safety ratings. Compliance with the safety ratings shall be ensured by means of suitable protective circuits.

**表 8-1. Package Insulation and Safety-Related Specifications
(over recommended operating conditions (unless otherwise noted))**

PARAMETER		TEST CONDITIONS	MIN	TYP	MAX	UNIT
CLR	External clearance	Shortest terminal-to-terminal distance through air	DW-16	8		mm
			DWW-16	14.5		
CPG	External creepage	Shortest terminal-to-terminal distance across the package surface	DW-16	8		mm
			DWW-16	14.5		
CTI	Comparative tracking index	DIN EN 60112 (VDE 0303-11); IEC 60112; UL 746A	600			V
R _{IO}	Isolation resistance, input to output ⁽¹⁾	V _{IO} = 500 V, T _A = 25°C	10 ¹²			Ω
		V _{IO} = 500 V, 100°C ≤ T _A ≤ max	10 ¹¹			Ω
C _{IO}	Barrier capacitance, input to output ⁽¹⁾	V _{IO} = 0.4 x sin (2 π ft), f = 1 MHz	1			pF
C _I	Input capacitance ⁽²⁾	V _I = V _{CC} /2 + 0.4 x sin (2 π ft), f = 1 MHz, V _{CC} = 5 V	2			pF

(1) All pins on each side of the barrier tied together creating a two-terminal device.

(2) Measured from input pin to ground.

备注

Creepage and clearance requirements should be applied according to the specific equipment isolation standards of an application. Care should be taken to maintain the creepage and clearance distance of a board design to ensure that the mounting pads of the isolator on the printed-circuit board do not reduce this distance.

Creepage and clearance on a printed-circuit board become equal in certain cases. Techniques such as inserting grooves and/or ribs on a printed circuit board are used to help increase these specifications.

表 8-2. Insulation Characteristics

PARAMETER		TEST CONDITIONS	SPECIFICATION		UNIT
			DW	DWW	
DTI	Distance through the insulation	Minimum internal gap (internal clearance)	21	21	μm
V _{IOWM}	Maximum working isolation voltage	Time dependent dielectric breakdown (TDDB) test	1500	2000	V _{RMS}
			2121	2828	V _{DC}
DIN V VDE V 0884-10 (VDE V 0884-10):2006-12					
V _{IOTM}	Maximum transient isolation voltage	V _{TEST} = V _{IOTM} t = 60 sec (qualification) t = 1 sec (100% production)	8000	8000	V _{PK}
V _{IOSM}	Maximum surge isolation voltage	Test method per IEC 60065, 1.2/50 μs waveform, V _{TEST} = 1.6 x V _{IOSM} = 12800 V _{PK} ⁽¹⁾ (qualification)	8000	8000	V _{PK}
V _{IORM}	Maximum repetitive peak isolation voltage		2121	2828	V _{PK}
V _{PR}	Input-to-output test voltage	Method a, After Input/Output safety test subgroup 2/3, V _{PR} = V _{IORM} x 1.2, t = 10 s, Partial discharge < 5 pC	2545	3394	V _{PK}
		Method a, After environmental tests subgroup 1, V _{PR} = V _{IORM} x 1.6, t = 10 s, Partial Discharge < 5 pC	3394	4525	
		Method b1, After environmental tests subgroup 1, V _{PR} = V _{IORM} x 1.875, t = 1 s (100% Production test) Partial discharge < 5 pC	3977	5303	
R _S	Isolation resistance	V _{IO} = 500 V at T _S	>10 ⁹	>10 ⁹	Ω
	Pollution degree		2	2	
	Climatic category		55/125/21	55/125/21	
UL 1577					
V _{ISO}	Withstanding isolation voltage	V _{TEST} = V _{ISO} = 5700 V _{RMS} , t = 60 sec (qualification); V _{TEST} = 1.2 x V _{ISO} = 6840 V _{RMS} , t = 1 sec (100% production)	5700	5700	V _{RMS}

(1) Testing is carried out in air or oil to determine the intrinsic surge immunity of the isolation barrier.

表 8-3. IEC 60664-1 Ratings Table

PARAMETER		TEST CONDITIONS	SPECIFICATION
Material group			I
Overvoltage category / Installation classification	DW package	Rated mains voltage ≤ 600 V _{RMS}	I - IV
		Rated mains voltage ≤ 1000 V _{RMS}	I - III
	DWW package	Rated mains voltage ≤ 1000 V _{RMS}	I - IV

8.3.1.1 Regulatory Information

DW package certifications are complete; DWW package certifications completed for UL and TUV and planned for VDE, CSA, and CQC.

表 8-4. Regulatory Information

VDE	CSA	UL	CQC	TUV
Certified according to DIN V VDE V 0884-10 (VDE V 0884-10):2006-12 and DIN EN 60950-1 (VDE 0805 Teil 1):2011-01	Approved under CSA Component Acceptance Notice 5A, IEC 60950-1 and IEC 60601-1	Recognized under UL 1577 Component Recognition Program	Certified according to GB 4943.1-2011	Certified according to EN 61010-1:2010 (3rd Ed) and EN 60950-1:2006/A11:2009/A1:2010/A12:2011/A2:2013
Reinforced insulation Maximum transient isolation voltage, 8000 V _{PK} ; Maximum repetitive peak isolation voltage, 2121 V _{PK} (DW), 2828 V _{PK} (DWW); Maximum surge isolation voltage, 8000 V _{PK}	Reinforced insulation per CSA 60950-1-07+A1+A2 and IEC 60950-1 2nd Ed., 800 V _{RMS} (DW package) and 1450 V _{RMS} (DWW package) max working voltage (pollution degree 2, material group I); 2 MOPP (Means of Patient Protection) per CSA 60601-1:14 and IEC 60601-1 Ed. 3.1, 250 V _{RMS} (354 V _{PK}) max working voltage (DW package)	Single protection, 5700 V _{RMS}	Reinforced Insulation, Altitude ≤ 5000 m, Tropical Climate, 250 V _{RMS} maximum working voltage	5700 V _{RMS} Reinforced insulation per EN 61010-1:2010 (3rd Ed) up to working voltage of 600 V _{RMS} (DW package) and 1000 V _{RMS} (DWW package) 5700 V _{RMS} Reinforced insulation per EN 60950-1:2006/A11:2009/A1:2010/A12:2011/A2:2013 up to working voltage of 800 V _{RMS} (DW package) and 1450 V _{RMS} (DWW package)
Certificate number: 40040142	Master contract number: 220991	File number: E181974	Certificate number: CQC15001121716	Client ID number: 77311

8.3.1.2 Safety Limiting Values

Safety limiting intends to prevent potential damage to the isolation barrier upon failure of input or output circuitry. A failure of the I/O can allow low resistance to ground or the supply and, without current limiting, dissipate sufficient power to overheat the die and damage the isolation barrier potentially leading to secondary system failures.

表 8-5. Safety Limiting

PARAMETER	TEST CONDITIONS	MIN	TYP	MAX	UNIT	
I _S	Safety input, output, or supply current for DW-16 package and DWW-16 Packages	R _{θJA} = 84.7°C/W, V _I = 5.5 V, T _J = 150°C, T _A = 25°C			268	mA
		R _{θJA} = 84.7°C/W, V _I = 3.6 V, T _J = 150°C, T _A = 25°C			410	
		R _{θJA} = 84.7°C/W, V _I = 2.75 V, T _J = 150°C, T _A = 25°C			537	
P _S	Safety input, output, or total power	R _{θJA} = 84.7°C/W, T _J = 150°C, T _A = 25°C			1476	mW
T _S	Maximum safety temperature				150	°C

The maximum safety temperature is the maximum junction temperature specified for the device. The power dissipation and junction-to-air thermal impedance of the device installed in the application hardware determines the junction temperature. The assumed junction-to-air thermal resistance in the 节 6.4 is that of a device installed on a High-K test board for Leaded Surface Mount Packages. The power is the recommended maximum input voltage times the current. The junction temperature is then the ambient temperature plus the power times the junction-to-air thermal resistance.

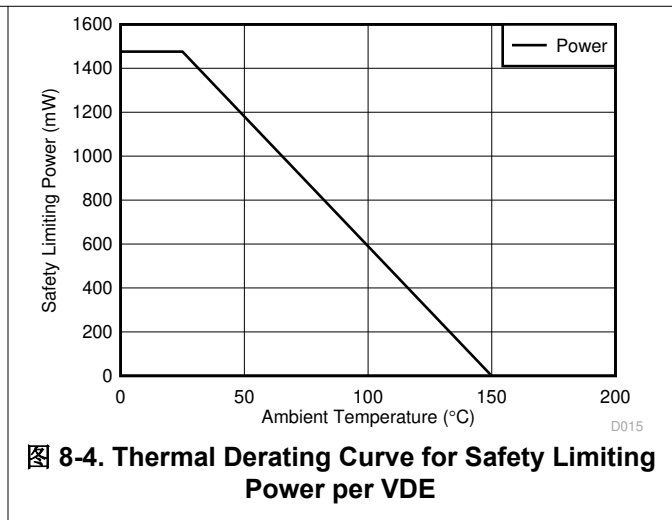
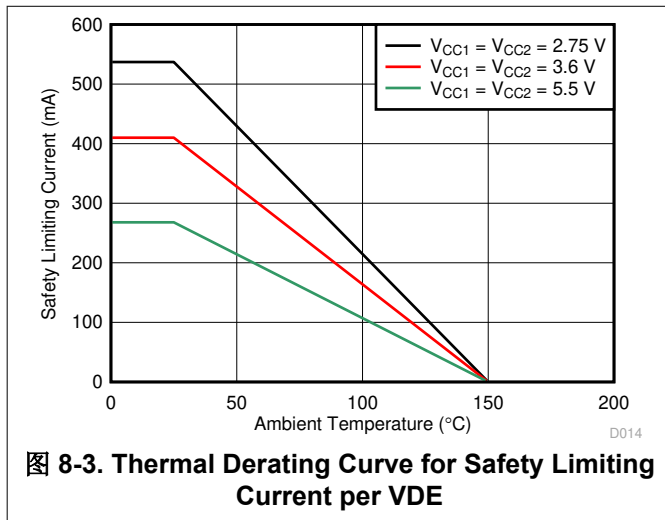

8.4 Device Functional Modes

ISO7821 functional modes are shown in 表 8-6.

表 8-6. ISO7821 Function Table

V _{CCI}	V _{CCO}	INPUT (IN _x) ⁽²⁾	OUTPUT ENABLE (EN _x) (DWW Package Only)	OUTPUT (OUT _x)	COMMENTS
PU	PU	H	H or open	H	Normal Operation: A channel output assumes the logic state of its input.
		L	H or open	L	
		Open	H or open	Default	Default mode: When IN _x is open, the corresponding channel output goes to its default high logic state. Default= High for ISO7821 and Low for ISO7821F.
X	PU	X	L	Z	A low value of Output Enable causes the outputs to be high-impedance.
PD	PU	X	H or open	Default	Default mode: When V _{CCI} is unpowered, a channel output assumes the logic state based on the selected default option. Default= High for ISO7821 and Low for ISO7821F. When V _{CCI} transitions from unpowered to powered-up, a channel output assumes the logic state of its input. When V _{CCI} transitions from powered-up to unpowered, channel output assumes the selected default state.
X	PD	X	X	Undetermined	When V _{CCO} is unpowered, a channel output is undetermined ⁽¹⁾ . When V _{CCO} transitions from unpowered to powered-up, a channel output assumes the logic state of its input

(1) The outputs are in undetermined state when $1.7\text{ V} < V_{CCI}$, $V_{CCO} < 2.25\text{ V}$.

(2) A strongly driven input signal can weakly power the floating V_{CC} via an internal protection diode and cause undetermined output.

8.4.1 Device I/O Schematics

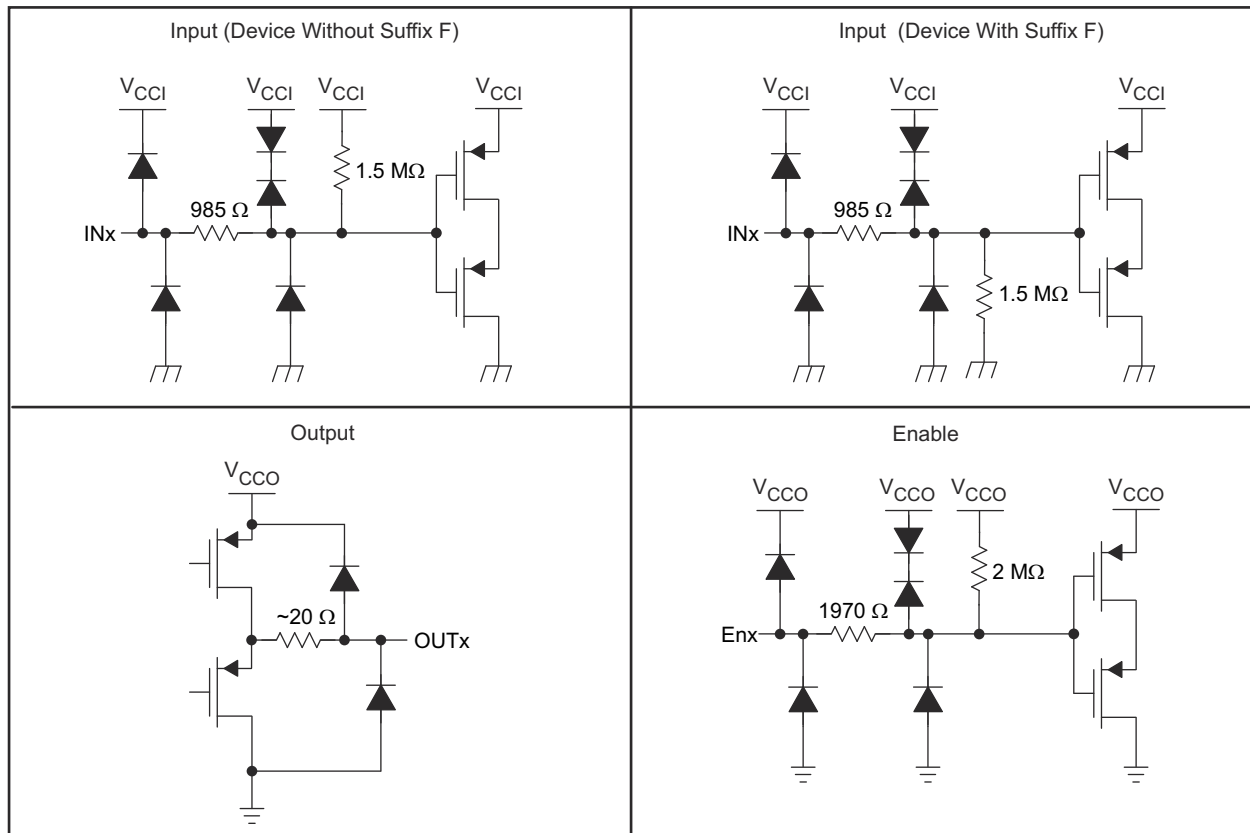

Copyright © 2016, Texas Instruments Incorporated

图 8-5. Device I/O Schematics

9 Application and Implementation

备注

Information in the following applications sections is not part of the TI component specification, and TI does not warrant its accuracy or completeness. TI's customers are responsible for determining suitability of components for their purposes, as well as validating and testing their design implementation to confirm system functionality.

9.1 Application Information

The ISO7821 is a high-performance, dual-channel digital isolator with 5.7 kV_{RMS} isolation voltage per UL 1577. It utilizes single-ended CMOS-logic switching technology. Its supply voltage range is from 2.25 V to 5.5 V for both supplies, V_{CC1} and V_{CC2}. When designing with digital isolators, it is important to keep in mind that due to the single-ended design structure, digital isolators do not conform to any specific interface standard and are only intended for isolating single-ended CMOS or TTL digital signal lines. The isolator is typically placed between the data controller (that is, μ C or UART), and a data converter or a line transceiver, regardless of the interface type or standard.

9.2 Typical Application

ISO7821 can be used with Texas Instruments' mixed signal micro-controller, digital-to-analog converter, transformer driver, and voltage regulator to create an isolated 4-20 mA current loop .



图 9-1. Isolated 4-20 mA Current Loop

9.2.1 Design Requirements

For the ISO7821, use the parameters shown in 表 9-1.

表 9-1. Design Parameters

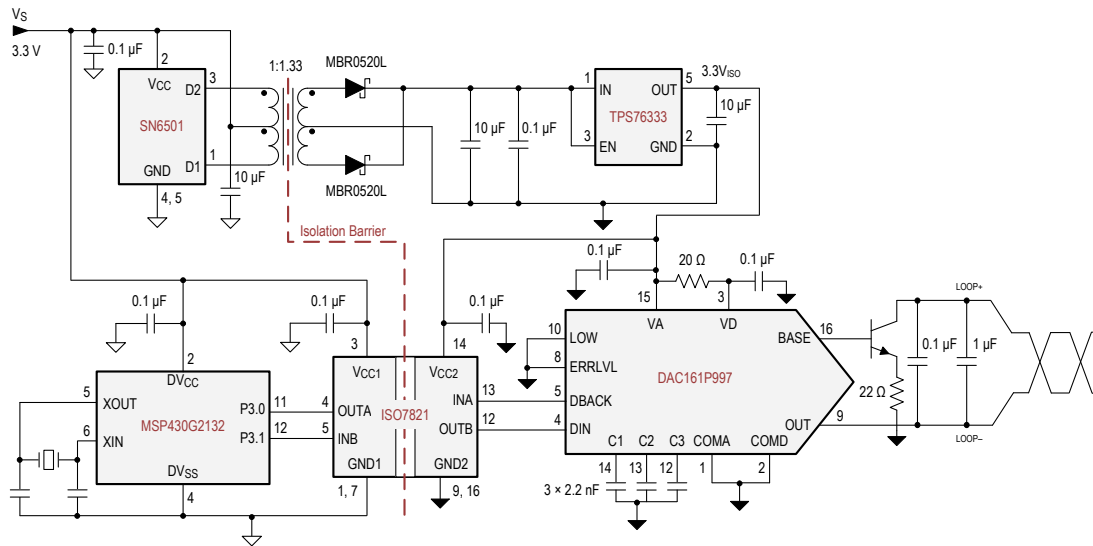
PARAMETER	VALUE
Supply voltage	2.25 V to 5.5 V
Decoupling capacitor between V _{CC1} and GND1	0.1 μ F
Decoupling capacitor from V _{CC2} and GND2	0.1 μ F

9.2.2 Detailed Design Procedure

Unlike optocouplers, which need external components to improve performance, provide bias, or limit current, ISO7821 only needs two external bypass capacitors to operate.



图 9-2. Typical ISO7821 Circuit Hook-up

9.2.2.1 Electromagnetic Compatibility (EMC) Considerations

Many applications in harsh industrial environment are sensitive to disturbances such as electrostatic discharge (ESD), electrical fast transient (EFT), surge and electromagnetic emissions. These electromagnetic disturbances are regulated by international standards such as IEC 61000-4-x and CISPR 22. Although system-level performance and reliability depends, to a large extent, on the application board design and layout, the ISO7821 incorporate many chip-level design improvements for overall system robustness. Some of these improvements include:

- Robust ESD protection for input and output signal pins and inter-chip bond pads.
- Low-resistance connectivity of ESD cells to supply and ground pins.
- Enhanced performance of high voltage isolation capacitor for better tolerance of ESD, EFT and surge events.
- Bigger on-chip decoupling capacitors to bypass undesirable high energy signals through a low impedance path.
- PMOS and NMOS devices isolated from each other by using guard rings to avoid triggering of parasitic SCRs.
- Reduced common mode currents across the isolation barrier by ensuring purely differential internal operation.

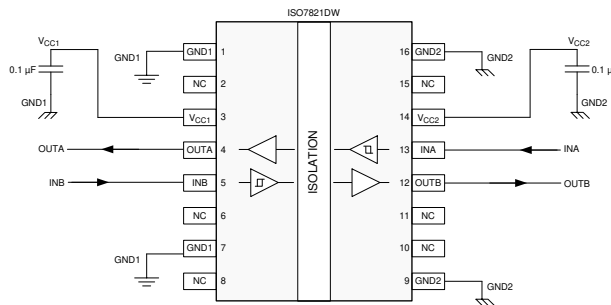
9.2.3 Application Performance Curve

Typical eye diagram of ISO7821 indicate low jitter and wide open eye at the maximum data rate of 100 Mbps.



图 9-3. Eye Diagram at 100 Mbps PRBS, 5 V and 25°C

Power Supply Recommendations

To ensure reliable operation at all data rates and supply voltages, a 0.1 μF bypass capacitor is recommended at input and output supply pins (V_{CC1} and V_{CC2}). The capacitors should be placed as close to the supply pins as possible. If only a single primary-side power supply is available in an application, isolated power can be generated for the secondary-side with the help of a transformer driver such as Texas Instruments' [SN6501](#). For such applications, detailed power supply design and transformer selection recommendations are available in [SN6501](#) datasheet ([SLLSEA0](#)).

10 Layout

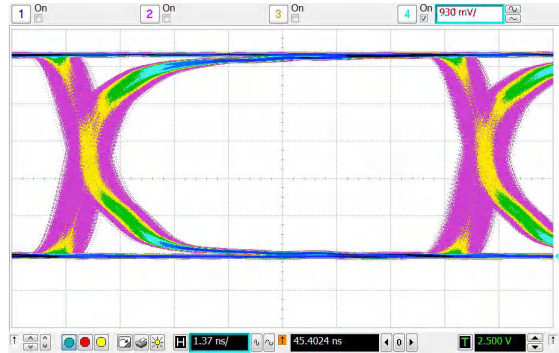
10.1 PCB Material

For digital circuit boards operating below 150 Mbps, (or rise and fall times higher than 1 ns), and trace lengths of up to 10 inches, use standard FR-4 epoxy-glass as PCB material. FR-4 (Flame Retardant 4) meets the requirements of Underwriters Laboratories UL94-V0, and is preferred over cheaper alternatives due to its lower dielectric losses at high frequencies, less moisture absorption, greater strength and stiffness, and its self-extinguishing flammability-characteristics.

10.2 Layout Guidelines

A minimum of four layers is required to accomplish a low EMI PCB design (see [图 10-1](#)). Layer stacking should be in the following order (top-to-bottom): high-speed signal layer, ground plane, power plane and low-frequency signal layer.

- Routing the high-speed traces on the top layer avoids the use of vias (and the introduction of their inductances) and allows for clean interconnects between the isolator and the transmitter and receiver circuits of the data link.
- Placing a solid ground plane next to the high-speed signal layer establishes controlled impedance for transmission line interconnects and provides an excellent low-inductance path for the return current flow.
- Placing the power plane next to the ground plane creates additional high-frequency bypass capacitance of approximately 100 pF/in².
- Routing the slower speed control signals on the bottom layer allows for greater flexibility as these signal links usually have margin to tolerate discontinuities such as vias.

If an additional supply voltage plane or signal layer is needed, add a second power / ground plane system to the stack to keep it symmetrical. This makes the stack mechanically stable and prevents it from warping. Also the power and ground plane of each power system can be placed closer together, thus increasing the high-frequency bypass capacitance significantly.

For detailed layout recommendations, see Application Note [SLLA284](#), *Digital Isolator Design Guide*.

10.3 Layout Example



图 10-1. Layout Example

11 Device and Documentation Support

11.1 Documentation Support

11.1.1 Related Documentation

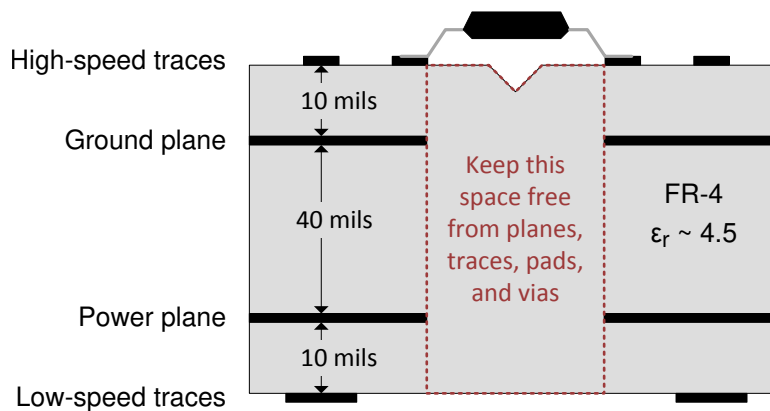
See the *Isolation Glossary* ([SLLA353](#))

11.2 Trademarks

所有商标均为其各自所有者的财产。

12 Mechanical, Packaging, and Orderable Information

The following pages include mechanical packaging and orderable information. This information is the most current data available for the designated devices. This data is subject to change without notice and revision of this document. For browser-based versions of this data sheet, refer to the left-hand navigation.

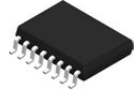

DW0016B

PACKAGE OUTLINE
SOIC - 2.65 mm max height

SOIC

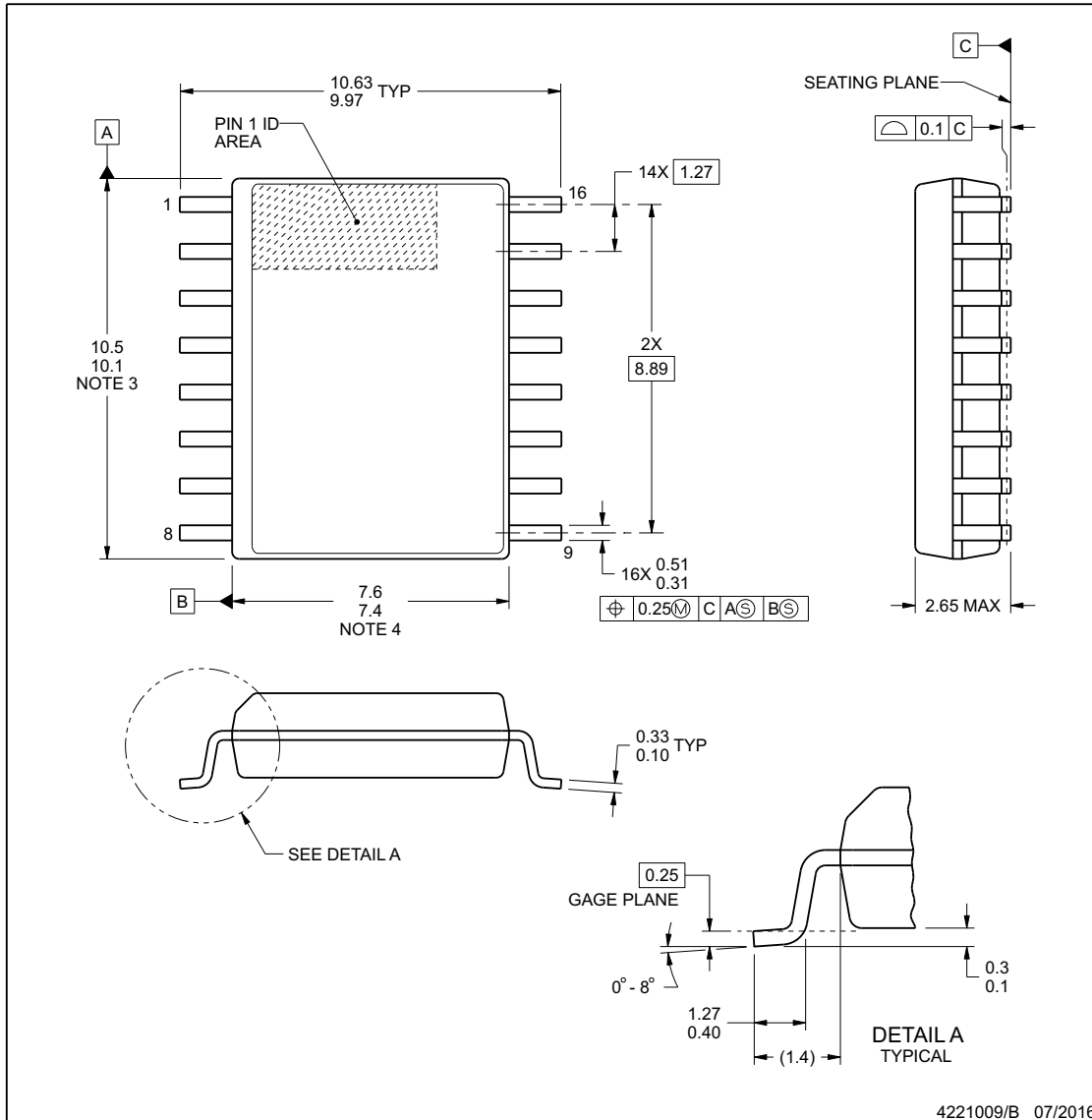

NOTES:

1. All linear dimensions are in millimeters. Dimensions in parenthesis are for reference only. Dimensioning and tolerancing per ASME Y14.5M.
2. This drawing is subject to change without notice.
3. This dimension does not include mold flash, protrusions, or gate burrs. Mold flash, protrusions, or gate burrs shall not exceed 0.15 mm, per side.
4. This dimension does not include interlead flash. Interlead flash shall not exceed 0.25 mm, per side.
5. Reference JEDEC registration MS-013.

www.ti.com

EXAMPLE BOARD LAYOUT

DW0016B

SOIC - 2.65 mm max height

SOIC

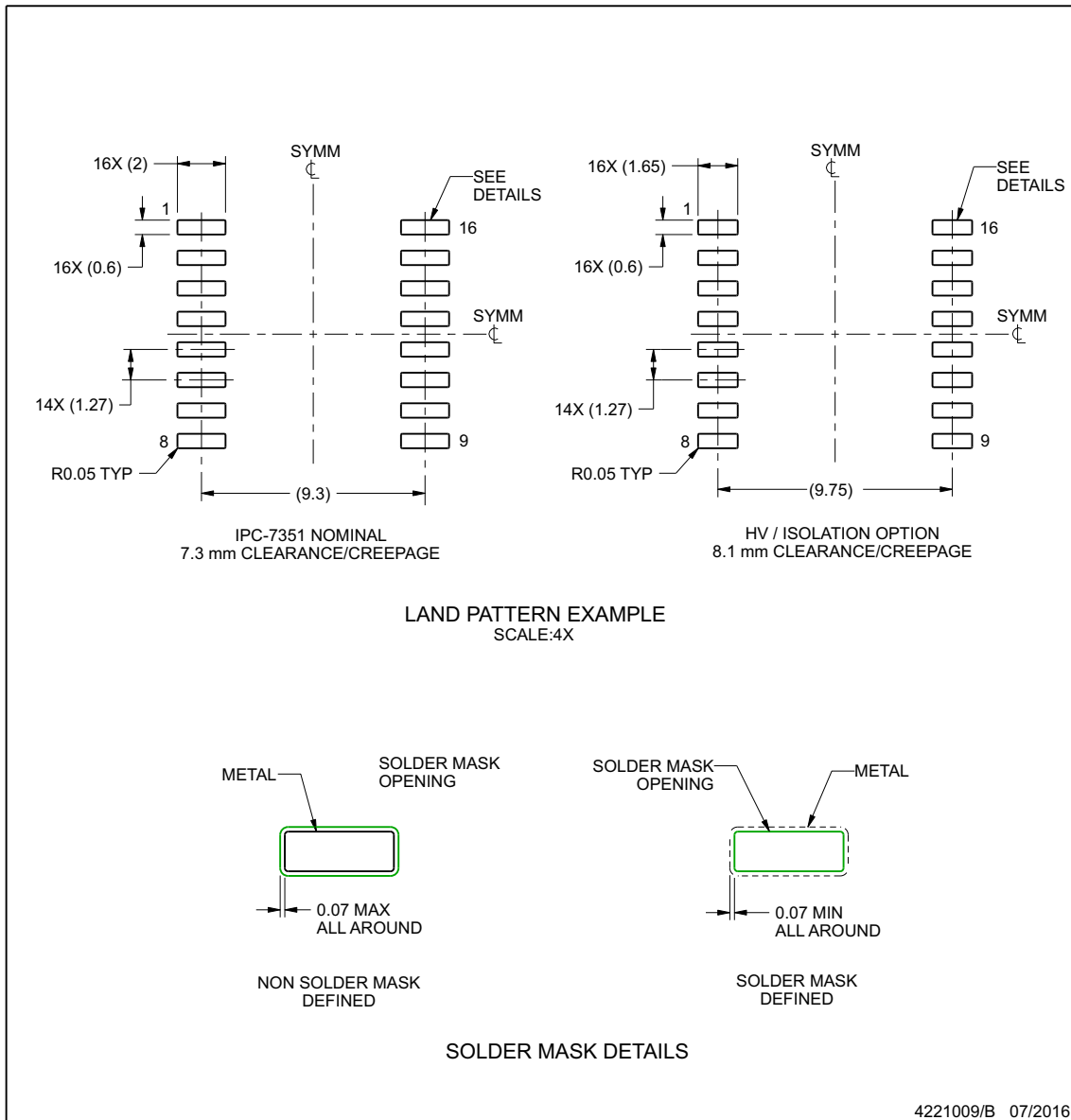

4221009/B 07/2016

NOTES: (continued)

6. Publication IPC-7351 may have alternate designs.

7. Solder mask tolerances between and around signal pads can vary based on board fabrication site.

www.ti.com

EXAMPLE STENCIL DESIGN

DW0016B

SOIC - 2.65 mm max height

SOIC

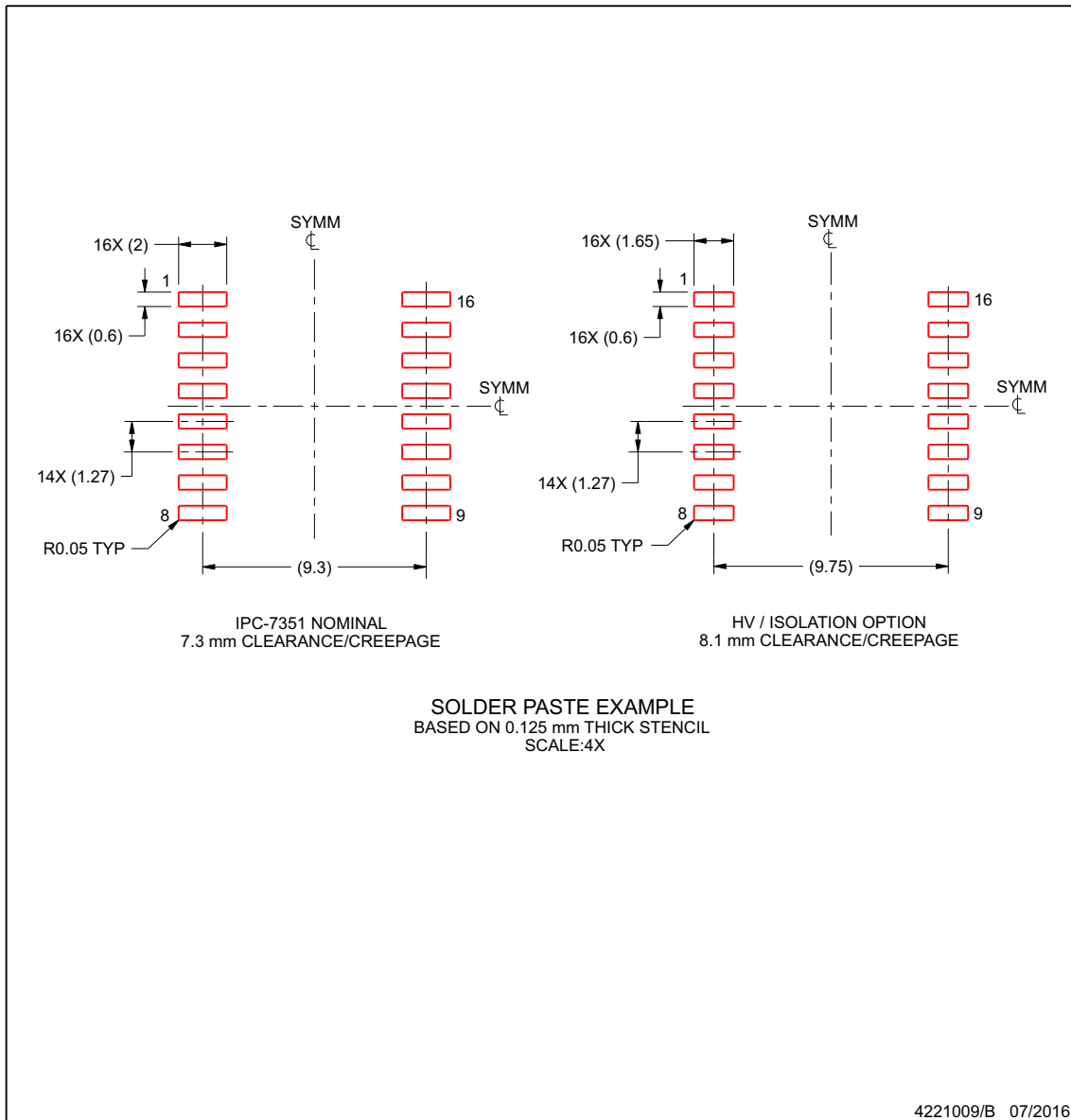

NOTES: (continued)

8. Laser cutting apertures with trapezoidal walls and rounded corners may offer better paste release. IPC-7525 may have alternate design recommendations.
9. Board assembly site may have different recommendations for stencil design.

www.ti.com



DWW0016A

PACKAGE OUTLINE
SOIC - 2.65 mm max height

PLASTIC SMALL OUTLINE

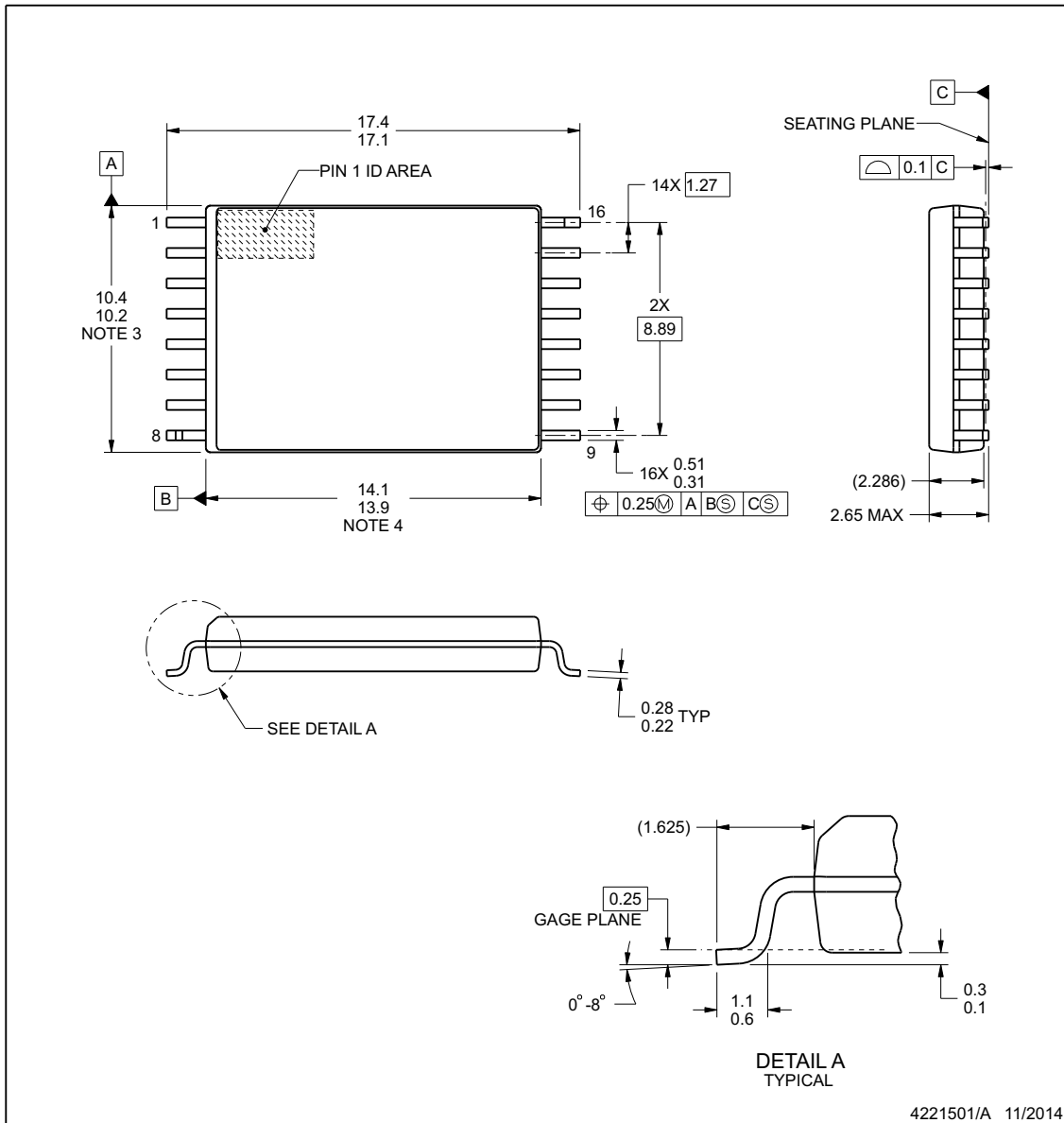

NOTES:

1. All linear dimensions are in millimeters. Any dimensions in parenthesis are for reference only. Dimensioning and tolerancing per ASME Y14.5M.
2. This drawing is subject to change without notice.
3. This dimension does not include mold flash, protrusions, or gate burrs. Mold flash, protrusions, or gate burrs shall not exceed 0,15 mm per side.
4. This dimension does not include interlead flash.

www.ti.com

EXAMPLE BOARD LAYOUT

DWW0016A

SOIC - 2.65 mm max height

PLASTIC SMALL OUTLINE

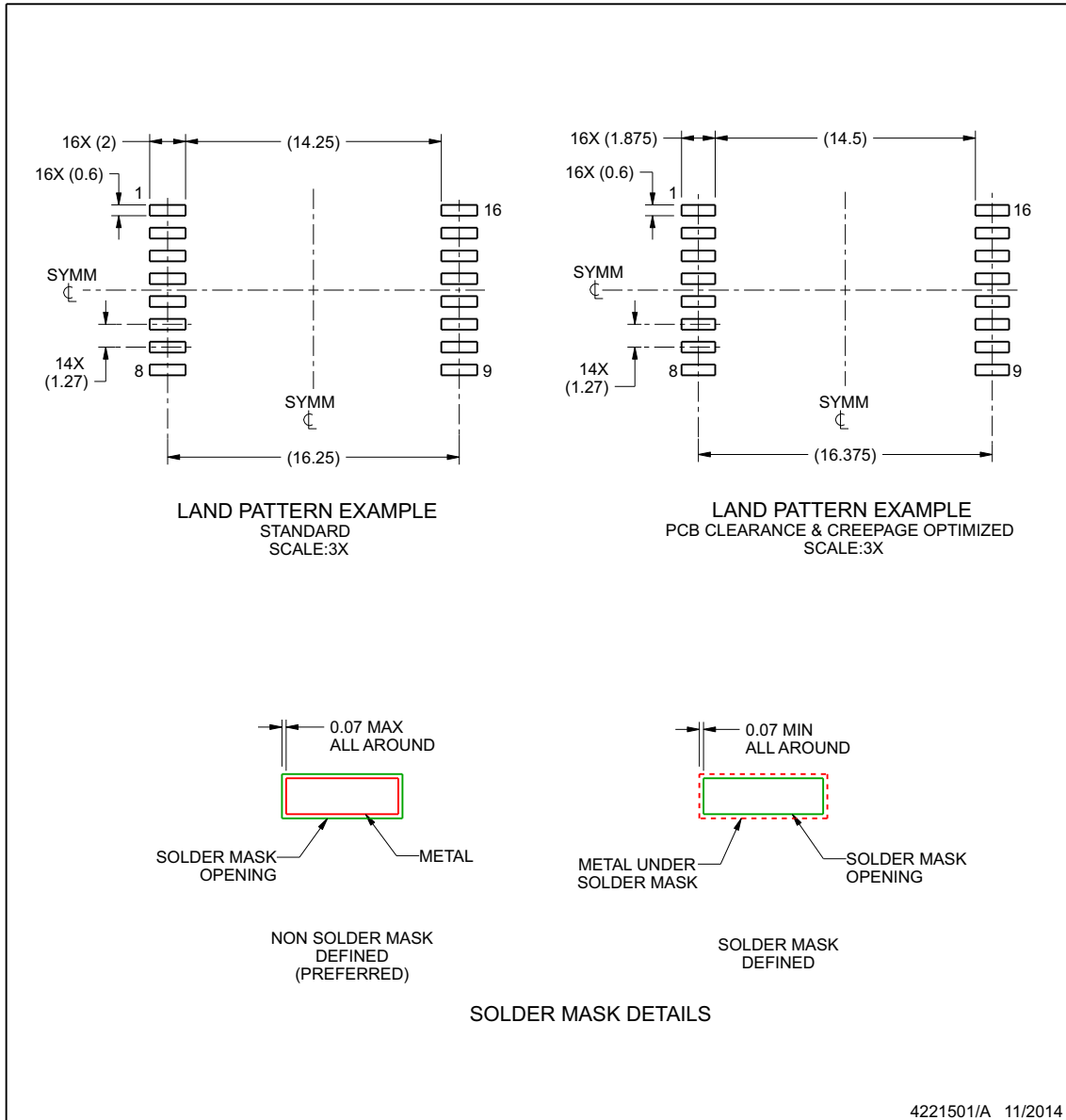

NOTES: (continued)

5. Publication IPC-7351 may have alternate designs.
6. Solder mask tolerances between and around signal pads can vary based on board fabrication site.

www.ti.com

EXAMPLE STENCIL DESIGN

DWW0016A

SOIC - 2.65 mm max height

PLASTIC SMALL OUTLINE

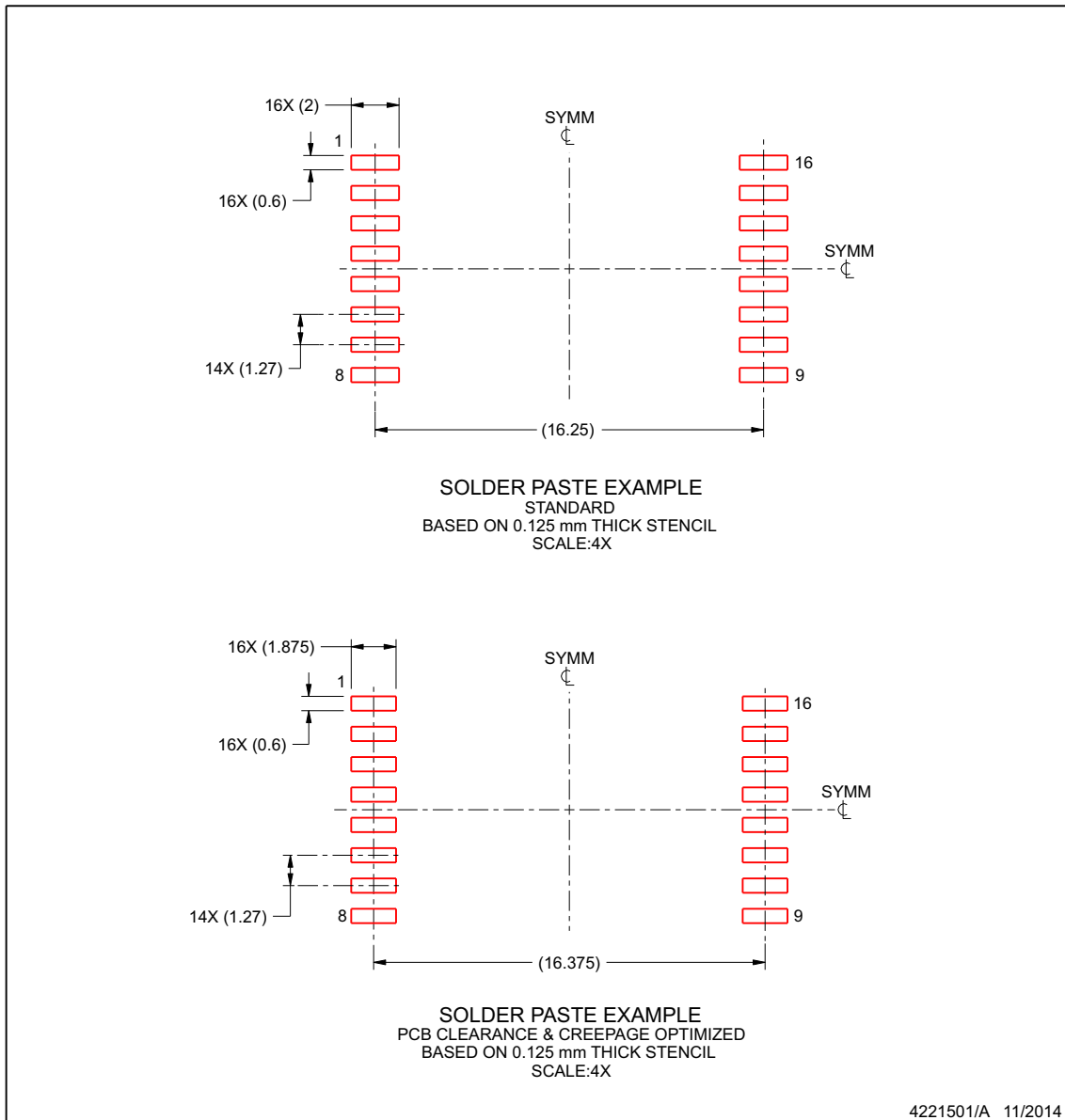

NOTES: (continued)

7. Laser cutting apertures with trapezoidal walls and rounded corners may offer better paste release. IPC-7525 may have alternate design recommendations.
8. Board assembly site may have different recommendations for stencil design.

www.ti.com

PACKAGING INFORMATION

Orderable Device	Status (1)	Package Type	Package Drawing	Pins	Package Qty	Eco Plan (2)	Lead finish/ Ball material (6)	MSL Peak Temp (3)	Op Temp (°C)	Device Marking (4/5)	Samples
ISO7821DW	ACTIVE	SOIC	DW	16	40	RoHS & Green	NIPDAU	Level-2-260C-1 YEAR	-55 to 125	ISO7821	Samples
ISO7821DWR	ACTIVE	SOIC	DW	16	2000	RoHS & Green	NIPDAU	Level-2-260C-1 YEAR	-55 to 125	ISO7821	Samples
ISO7821DWW	ACTIVE	SOIC	DWW	16	45	RoHS & Green	NIPDAU	Level-3-260C-168 HR	-55 to 125	ISO7821	Samples
ISO7821DWWR	ACTIVE	SOIC	DWW	16	1000	RoHS & Green	NIPDAU	Level-3-260C-168 HR	-55 to 125	ISO7821	Samples
ISO7821FDW	ACTIVE	SOIC	DW	16	40	RoHS & Green	NIPDAU	Level-2-260C-1 YEAR	-55 to 125	ISO7821F	Samples
ISO7821FDWR	ACTIVE	SOIC	DW	16	2000	RoHS & Green	NIPDAU	Level-2-260C-1 YEAR	-55 to 125	ISO7821F	Samples
ISO7821FDWW	ACTIVE	SOIC	DWW	16	45	RoHS & Green	NIPDAU	Level-3-260C-168 HR	-55 to 125	ISO7821F	Samples
ISO7821FDWWR	ACTIVE	SOIC	DWW	16	1000	RoHS & Green	NIPDAU	Level-3-260C-168 HR	-55 to 125	ISO7821F	Samples

(1) The marketing status values are defined as follows:

ACTIVE: Product device recommended for new designs.

LIFEBUY: TI has announced that the device will be discontinued, and a lifetime-buy period is in effect.

NRND: Not recommended for new designs. Device is in production to support existing customers, but TI does not recommend using this part in a new design.

PREVIEW: Device has been announced but is not in production. Samples may or may not be available.

OBSOLETE: TI has discontinued the production of the device.

(2) **RoHS:** TI defines "RoHS" to mean semiconductor products that are compliant with the current EU RoHS requirements for all 10 RoHS substances, including the requirement that RoHS substance do not exceed 0.1% by weight in homogeneous materials. Where designed to be soldered at high temperatures, "RoHS" products are suitable for use in specified lead-free processes. TI may reference these types of products as "Pb-Free".

RoHS Exempt: TI defines "RoHS Exempt" to mean products that contain lead but are compliant with EU RoHS pursuant to a specific EU RoHS exemption.

Green: TI defines "Green" to mean the content of Chlorine (Cl) and Bromine (Br) based flame retardants meet JS709B low halogen requirements of <=1000ppm threshold. Antimony trioxide based flame retardants must also meet the <=1000ppm threshold requirement.

(3) MSL, Peak Temp. - The Moisture Sensitivity Level rating according to the JEDEC industry standard classifications, and peak solder temperature.

(4) There may be additional marking, which relates to the logo, the lot trace code information, or the environmental category on the device.

(5) Multiple Device Markings will be inside parentheses. Only one Device Marking contained in parentheses and separated by a "~" will appear on a device. If a line is indented then it is a continuation of the previous line and the two combined represent the entire Device Marking for that device.

⁽⁶⁾ Lead finish/Ball material - Orderable Devices may have multiple material finish options. Finish options are separated by a vertical ruled line. Lead finish/Ball material values may wrap to two lines if the finish value exceeds the maximum column width.

Important Information and Disclaimer: The information provided on this page represents TI's knowledge and belief as of the date that it is provided. TI bases its knowledge and belief on information provided by third parties, and makes no representation or warranty as to the accuracy of such information. Efforts are underway to better integrate information from third parties. TI has taken and continues to take reasonable steps to provide representative and accurate information but may not have conducted destructive testing or chemical analysis on incoming materials and chemicals. TI and TI suppliers consider certain information to be proprietary, and thus CAS numbers and other limited information may not be available for release.

In no event shall TI's liability arising out of such information exceed the total purchase price of the TI part(s) at issue in this document sold by TI to Customer on an annual basis.

TAPE AND REEL INFORMATION

QUADRANT ASSIGNMENTS FOR PIN 1 ORIENTATION IN TAPE

*All dimensions are nominal

Device	Package Type	Package Drawing	Pins	SPQ	Reel Diameter (mm)	Reel Width W1 (mm)	A0 (mm)	B0 (mm)	K0 (mm)	P1 (mm)	W (mm)	Pin1 Quadrant
ISO7821DWR	SOIC	DW	16	2000	330.0	16.4	10.75	10.7	2.7	12.0	16.0	Q1
ISO7821DWWR	SOIC	DWW	16	1000	330.0	24.4	18.0	10.0	3.0	20.0	24.0	Q1
ISO7821FDWR	SOIC	DW	16	2000	330.0	16.4	10.75	10.7	2.7	12.0	16.0	Q1
ISO7821FDWWR	SOIC	DWW	16	1000	330.0	24.4	18.0	10.0	3.0	20.0	24.0	Q1

TAPE AND REEL BOX DIMENSIONS



*All dimensions are nominal

Device	Package Type	Package Drawing	Pins	SPQ	Length (mm)	Width (mm)	Height (mm)
ISO7821DWR	SOIC	DW	16	2000	350.0	350.0	43.0
ISO7821DWWR	SOIC	DWW	16	1000	350.0	350.0	43.0
ISO7821FDWR	SOIC	DW	16	2000	350.0	350.0	43.0
ISO7821FDWWR	SOIC	DWW	16	1000	350.0	350.0	43.0

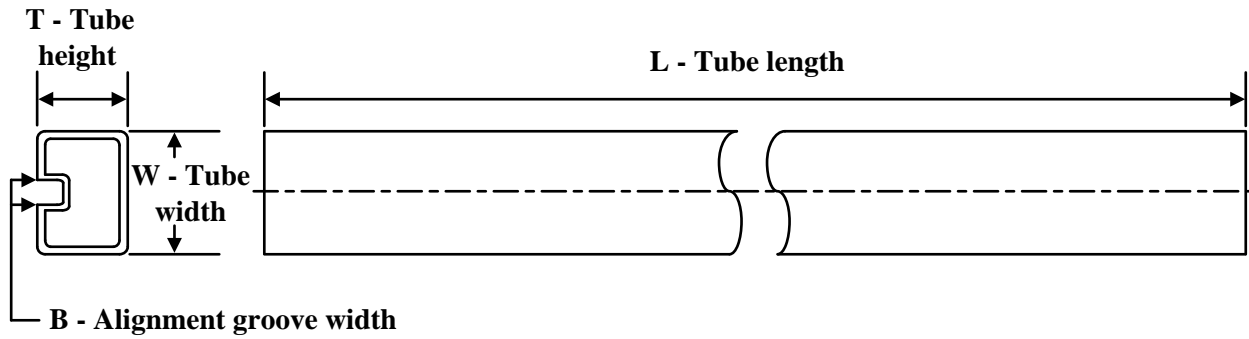
TUBE

*All dimensions are nominal

Device	Package Name	Package Type	Pins	SPQ	L (mm)	W (mm)	T (μm)	B (mm)
ISO7821DW	DW	SOIC	16	40	506.98	12.7	4826	6.6
ISO7821DWW	DWW	SOIC	16	45	507	20	5000	9
ISO7821FDW	DW	SOIC	16	40	506.98	12.7	4826	6.6
ISO7821FDWW	DWW	SOIC	16	45	507	20	5000	9

重要声明和免责声明

TI“按原样”提供技术和可靠性数据（包括数据表）、设计资源（包括参考设计）、应用或其他设计建议、网络工具、安全信息和其他资源，不保证没有瑕疵且不做任何明示或暗示的担保，包括但不限于对适销性、某特定用途方面的适用性或不侵犯任何第三方知识产权的暗示担保。

这些资源可供使用 TI 产品进行设计的熟练开发人员使用。您将自行承担以下全部责任：(1) 针对您的应用选择合适的 TI 产品，(2) 设计、验证并测试您的应用，(3) 确保您的应用满足相应标准以及任何其他功能安全、信息安全、监管或其他要求。

这些资源如有变更，恕不另行通知。TI 授权您仅可将这些资源用于研发本资源所述的 TI 产品的应用。严禁对这些资源进行其他复制或展示。您无权使用任何其他 TI 知识产权或任何第三方知识产权。您应全额赔偿因在这些资源的使用中对 TI 及其代表造成的任何索赔、损害、成本、损失和债务，TI 对此概不负责。

TI 提供的产品受 [TI 的销售条款](#) 或 [ti.com](#) 上其他适用条款/TI 产品随附的其他适用条款的约束。TI 提供这些资源并不会扩展或以其他方式更改 TI 针对 TI 产品发布的适用的担保或担保免责声明。

TI 反对并拒绝您可能提出的任何其他或不同的条款。

邮寄地址：Texas Instruments, Post Office Box 655303, Dallas, Texas 75265

Copyright © 2022，德州仪器 (TI) 公司