

ISO7841x 高性能、8000V_{PK} 增强型四通道数字隔离器

1 特性

- 信号传输速率：高达 100Mbps
- 宽电源电压范围：2.25V 至 5.5V
- 2.25V 至 5.5V 电平转换
- 宽温度范围：-55°C 至 +125°C
- 低功耗：电流典型值为 1.7mA/通道（1Mbps 时）
- 低传播延迟：典型值为 11ns（5V 电源供电时）
- 行业领先的 CMTI（最小值）：±100 kV/μs
- 优异的电磁兼容性 (EMC)
- 系统级静电放电 (ESD)、瞬态放电 (EFT) 以及抗浪涌保护
- 低辐射
- 隔离层寿命：40 年以上
- 宽体 SOIC-16 封装和超宽体 SOIC-16 封装选项
- 安全及管理批准：中的“安全及管理批准”列表中的“安全及管理批准”列表
 - 8000 V_{PK} 增强型隔离，符合 DIN V VDE V 0884-10 (VDE V 0884-10)：2006-12
 - 符合 UL 1577 标准且长达 1 分钟的 5.7kV_{RMS} 隔离
 - CSA 组件验收通知 5A, IEC 60950-1 和 IEC 60601-1 终端设备标准
 - 符合 GB4943.1-2011 标准的 CQC 认证
 - 符合 EN 61010-1 和 EN 60950-1 标准的 TUV 认证
 - 完成了所有 DW 封装认证；完成了符合 UL、VDE、TUV 标准的 DWW 封装认证并且已针对 CSA 和 CQC 进行了规划

2 应用

- 工业自动化
- 电机控制
- 电源
- 太阳能逆变器
- 医疗设备
- 混合动力电动汽车

3 说明

ISO7841x 器件是一款高性能四通道数字隔离器，隔离电压为 8000V_{PK}。该器件已通过符合 VDE、CSA、CQC 和 TUV 标准的增强型隔离认证。在隔离互补金属氧化物半导体 (CMOS) 或者低电压互补金属氧化物半导体 (LVCMOS) 数字 I/O 时，该隔离器可提供高电磁抗扰度和低辐射，同时具备低功耗特性。每个隔离通道都有一个由二氧化硅 (SiO₂) 绝缘隔栅分开的逻辑输入和输出缓冲器。

该器件配有使能引脚，可用于将多个主驱动应用中的相应输出置于高阻抗状态，也可用于降低功耗。

ISO7841 器件具有 3 个正向通道和 1 个反向通道。如果出现输入功率或信号丢失，ISO7841 器件默认输出高电平，ISO7841F 器件默认输出低电平。有关更多详细信息，请参阅 [Device Functional Modes](#) 器件功能模式部分。

与隔离式电源结合使用时，该器件有助于防止数据总线或者其他电路中的噪声电流进入本地接地，进而干扰或损坏敏感电路。凭借创新的芯片设计和布线技术，ISO7841 器件的电磁兼容性得到了显著增强，可确保提供系统级 ESD、EFT 和浪涌保护并符合辐射标准。

ISO7841 器件采用 16 引脚 SOIC 宽体 (DW) 和超宽体 (DWW) 封装。

器件信息⁽¹⁾

产品型号	封装	封装尺寸 (标称值)
ISO7841	DW (16)	10.30mm x 7.50mm
ISO7841F	DWW (16)	10.30mm x 14.0mm

(1) 要了解所有可用封装，请参阅数据表末尾的可订购产品附录。

简化电路原理图

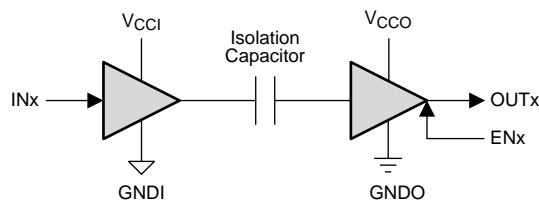

V_{CCI} 和 GNDI 分别是输入通道的电源和接地连接。

V_{CCO} 和 GNDO 分别是输出通道的电源和接地连接。



目录

1 特性	1	6.19 Typical Characteristics	16
2 应用	1	7 Parameter Measurement Information	17
3 说明	1	8 Detailed Description	19
4 修订历史记录	2	8.1 Overview	19
5 Pin Configuration and Functions	5	8.2 Functional Block Diagram	19
6 Specifications	6	8.3 Feature Description	20
6.1 Absolute Maximum Ratings	6	8.4 Device Functional Modes	21
6.2 ESD Ratings	6	9 Application and Implementation	22
6.3 Recommended Operating Conditions	6	9.1 Application Information	22
6.4 Thermal Information	7	9.2 Typical Application	22
6.5 Power Ratings	7	10 Power Supply Recommendations	24
6.6 Insulation Specifications	8	11 Layout	25
6.7 Safety-Related Certifications	9	11.1 Layout Guidelines	25
6.8 Safety Limiting Values	9	11.2 Layout Example	25
6.9 Electrical Characteristics—5-V Supply	10	12 器件和文档支持	26
6.10 Supply Current Characteristics—5-V Supply	10	12.1 文档支持	26
6.11 Electrical Characteristics—3.3-V Supply	11	12.2 相关链接	26
6.12 Electrical Characteristics—3.3-V Supply	11	12.3 接收文档更新通知	26
6.13 Electrical Characteristics—2.5-V Supply	12	12.4 社区资源	26
6.14 Supply Current Characteristics—2.5-V Supply	12	12.5 商标	26
6.15 Switching Characteristics—5-V Supply	13	12.6 静电放电警告	26
6.16 Switching Characteristics—3.3-V Supply	13	12.7 Glossary	26
6.17 Switching Characteristics—2.5-V Supply	14	13 机械、封装和可订购信息	27
6.18 Insulation Characteristics Curves	15		

4 修订历史记录

注：之前版本的页码可能与当前版本有所不同。

Changes from Revision F (April 2016) to Revision G	Page
• Changed part numbers in the <i>Power Ratings</i> table (previously <i>Power Dissipation Characteristics</i>)	7
• Changed the input-to-output test voltage parameter to apparent charge in the <i>Insulation Specifications</i>	8
• 已添加 接收文档更新通知部分	26

Changes from Revision E (March 2016) to Revision F	Page
• 已更改 隔离层寿命年数（特性部分）	1
• VDE 认证现在已完成	1
• Changed V_{CCO} to V_{CCI} for the minimum value of the input threshold voltage hysteresis parameter in all electrical characteristics tables	10
• Added V_{CM} to the test condition of the common-mode transient immunity parameter in all electrical characteristics tables	10
• Added the lifetime projection graphs for DW and DWW packages to the <i>Safety Limiting Values</i> section	15

Changes from Revision D (December 2015) to Revision E	Page
• 更改了“安全及管理批准”列表特性	1
• 在特性中添加了“符合 EN 61010-1 和 EN 60950-1 标准的 TUV 认证”	1
• 将说明的第一段中的文本从“符合 VDE、CSA 和 CQC 的认证”更改为“符合 VDE、CSA、CQC 和 TUV 的认证。”	1
• Added Note 1 to <i>Insulation Characteristics</i>	8
• Changed <i>IEC 60664-1 Ratings Table</i>	8

• Added TUV to the <i>Regulatory Information</i> section and Regulatory Information. Deleted Note 1 in Regulatory Information	9
• Changed <i>Device I/O Schematics</i>	21

Changes from Revision C (July 2015) to Revision D **Page**

• 在特性中添加了“完成了 DW 封装认证；规划了 DWW 认证”.....	1
• 向说明部分添加了文本：“和超宽体 (DWW) 封装”。.....	1
• 已将封装“超宽 SOIC、DWW (16)”添加至器件信息表.....	1
• Added the 16-DWW Package to <i>Package Insulation and Safety-Related Specifications</i>	8
• Added the DWW package information to <i>Package Insulation and Safety-Related Specifications</i>	8
• Added the DWW package information to <i>Regulatory Information</i>	9
• Changed the MIN value of CMTI in <i>Electrical Characteristics—5-V Supply</i> , 5 V table From: 70 To: 100 kV/μs, deleted the TYP value of 100 kV/μs	10
• Added the Supply Current - ISO7841DW and ISO7841FDW section to the <i>Supply Current Characteristics—5-V Supply</i>	10
• Added the Supply Current - ISO7841DWW and ISO7841FDWW section to the <i>Supply Current Characteristics—5-V Supply</i>	10
• Changed the MIN value of CMTI in <i>Electrical Characteristics—3.3-V Supply</i> , 5 V table From: 70 To: 100 kV/μs, deleted the TYP value of 100 kV/μs	11
• Added the Supply Current - ISO7841DW and ISO7841FDW section to the <i>Electrical Characteristics—3.3-V Supply</i>	11
• Added the Supply Current - ISO7841DWW and ISO7841FDWW section to the <i>Electrical Characteristics—3.3-V Supply</i>	11
• Changed the MIN value of CMTI in <i>Electrical Characteristics—2.5-V Supply</i> , 5 V table From: 70 To: 100 kV/μs, deleted the TYP value of 100 kV/μs	12
• Added the Supply Current - ISO7841DW and ISO7841FDW section to the <i>Supply Current Characteristics—2.5-V Supply</i>	12
• Added the Supply Current - ISO7841DWW and ISO7841FDWW section to the <i>Supply Current Characteristics—2.5-V Supply</i>	12
• Added text to the <i>Application Information</i> section: " isolation voltage per UL 1577."	22

Changes from Revision B (January 2015) to Revision C **Page**

• 已添加器件 ISO7481F 至数据表.....	1
• 已更改 说明以包含“ISO7841 器件默认输出为“高”，ISO7841F 器件默认输出为“低””。.....	1
• Changed From: t_{PLH} and t_{PHL} at 5.5V To: t_{PLH} and t_{PHL} at 5.0 V	16
• Changed <i>Default Output Delay Time Test Circuit and Voltage Waveforms</i>	18
• Added the <i>Device I/O Schematics</i> section	21

Changes from Revision A (January 2015) to Revision B **Page**

• 已将文档标题从“四通道数字隔离器”更改为“四通道 3/1 数字隔离器”	1
• 在特性部分添加了“2.25V 至 5.5V 电平转换”.....	1
• 将特性中的“宽体 SOIC-16 封装”更改为“宽体和超宽体 SOIC-16 封装选项”.....	1
• 更改了特性.....	1
• VDE 认证现在已完成	1
• 更改了简化电路原理图并增加了注释 1 和注释 2	1
• Added the <i>Power Dissipation Characteristics</i> table.....	7
• Changed <i>Package Insulation and Safety-Related Specifications</i> title From: <i>IEC Insulation and Safety-Related Specifications for DW-16 Package</i> To: <i>Package Insulation and Safety-Related Specifications</i>	8
• Changed <i>Package Insulation and Safety-Related Specifications</i>	8

• Changed <i>Insulation Characteristics</i> title From: <i>DIN V VDE 0884-10 (VDE V 0884-10) and UL 1577 Insulation Characteristics</i> To: <i>Insulation Characteristics</i>	8
• Changed <i>Insulation Characteristics</i>	8
• Changed the Test Condition of CTI of the table in <i>Package Insulation and Safety-Related Specifications</i>	8
• Changed the MIN value of CTI From" > 600 V To: 600 V	8
• Changed title From: <i>Regulatory Information (All Certifications Planned)Regulatory Information (All Certifications Planned)</i> To: <i>Regulatory Information</i>	9
• Changed the table in <i>Regulatory Information</i>	9
• Changed <i>Safety Limiting Values</i> , added I_S DW-16 package options	9
• Changed <i>Switching Characteristics Test Circuit and Voltage Waveforms</i>	17
• Changed <i>Enable/Disable Propagation Delay Time Test Circuit and Waveform</i>	17
• Changed From: V_{CC1} To: V_{CC1} in <i>Default Output Delay Time Test Circuit and Voltage Waveforms</i>	18
• Changed <i>Common-Mode Transient Immunity Test Circuit</i>	18
• Deleted INPUT-SIDE and OUTPUT-SIDE from columns 1 and 2 of <i>Function Table</i>	21
• Changed the <i>Application Information</i> section	22
• Changed the <i>Application Information</i> section	22

Changes from Original (November 2014) to Revision A
Page

• 已将器件状态从“产品预览”更新为“量产数据”	1
--------------------------------	---

5 Pin Configuration and Functions

**DW and DWW Packages
16-Pin SOIC
Top View**

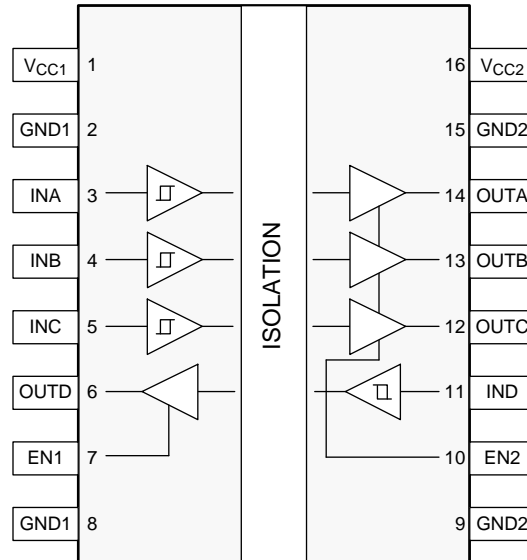

Pin Functions

PIN		I/O	DESCRIPTION
NAME	NO.		
EN1	7	I	Output enable 1. Output pins on side 1 are enabled when EN1 is high or open and in high-impedance state when EN1 is low.
EN2	10	I	Output enable 2. Output pins on side 2 are enabled when EN2 is high or open and in high-impedance state when EN2 is low.
GND1	2	—	Ground connection for V_{CC1}
	8		
GND2	9	—	Ground connection for V_{CC2}
	15		
INA	3	I	Input, channel A
INB	4	I	Input, channel B
INC	5	I	Input, channel C
IND	11	I	Input, channel D
OUTA	14	O	Output, channel A
OUTB	13	O	Output, channel B
OUTC	12	O	Output, channel C
OUTD	6	O	Output, channel D
V_{CC1}	1	—	Power supply, V_{CC1}
V_{CC2}	16	—	Power supply, V_{CC2}

6 Specifications

6.1 Absolute Maximum Ratings

 See ⁽¹⁾

		MIN	MAX	UNIT
V_{CC1} , V_{CC2}	Supply voltage ⁽²⁾	-0.5	6	V
Voltage	INx	-0.5	$V_{CCX} + 0.5$ ⁽³⁾	V
	OUTx	-0.5	$V_{CCX} + 0.5$ ⁽³⁾	
	ENx	-0.5	$V_{CCX} + 0.5$ ⁽³⁾	
I_O	Output current	-15	15	mA
	Surge immunity		12.8	kV
T_{stg}	Storage temperature	-65	150	°C

- (1) Stresses beyond those listed under *Absolute Maximum Ratings* may cause permanent damage to the device. These are stress ratings only and functional operation of the device at these or any other conditions beyond those indicated under *Recommended Operating Conditions* is not implied. Exposure to absolute-maximum-rated conditions for extended periods may affect device reliability.
- (2) All voltage values except differential I/O bus voltages are with respect to the local ground terminal (GND1 or GND2) and are peak voltage values.
- (3) Maximum voltage must not exceed 6 V

6.2 ESD Ratings

		VALUE	UNIT
$V_{(ESD)}$	Electrostatic discharge	Human body model (HBM), per ANSI/ESDA/JEDEC JS-001, all pins ⁽¹⁾	±6000
		Charged device model (CDM), per JEDEC specification JESD22-C101, all pins ⁽²⁾	±1500

- (1) JEDEC document JEP155 states that 500-V HBM allows safe manufacturing with a standard ESD control process.
- (2) JEDEC document JEP157 states that 250-V CDM allows safe manufacturing with a standard ESD control process.

6.3 Recommended Operating Conditions

		MIN	NOM	MAX	UNIT
V_{CC1} , V_{CC2}	Supply voltage	2.25		5.5	V
I_{OH}	High-level output current	$V_{CCO}^{(1)} = 5$ V		-4	mA
		$V_{CCO}^{(1)} = 3.3$ V		-2	
		$V_{CCO}^{(1)} = 2.5$ V		-1	
I_{OL}	Low-level output current	$V_{CCO}^{(1)} = 5$ V		4	mA
		$V_{CCO}^{(1)} = 3.3$ V		2	
		$V_{CCO}^{(1)} = 2.5$ V		1	
V_{IH}	High-level input voltage	$0.7 \times V_{CCI}^{(1)}$		$V_{CCI}^{(1)}$	V
V_{IL}	Low-level input voltage	0		$0.3 \times V_{CCI}^{(1)}$	V
DR	Signaling rate	0		100	Mbps
T_J	Junction temperature ⁽²⁾	-55		150	°C
T_A	Ambient temperature	-55	25	125	°C

- (1) V_{CCI} = Input-side V_{CC} ; V_{CCO} = Output-side V_{CC} .
- (2) To maintain the recommended operating conditions for T_J , see [Thermal Information](#).

6.4 Thermal Information

THERMAL METRIC ⁽¹⁾		ISO7841		UNIT
		DW (SOIC)	DWW (SOIC)	
		16 Pins	16 Pins	
$R_{\theta JA}$	Junction-to-ambient thermal resistance	78.9	78.9	°C/W
$R_{\theta JC(top)}$	Junction-to-case(top) thermal resistance	41.6	41.1	°C/W
$R_{\theta JB}$	Junction-to-board thermal resistance	43.6	49.5	°C/W
Ψ_{JT}	Junction-to-top characterization parameter	15.5	15.2	°C/W
Ψ_{JB}	Junction-to-board characterization parameter	43.1	48.8	°C/W
$R_{\theta JC(bottom)}$	Junction-to-case(bottom) thermal resistance	N/A	N/A	°C/W

(1) For more information about traditional and new thermal metrics, see the [Semiconductor and IC Package Thermal Metrics](#) application report.

6.5 Power Ratings

$V_{CC1} = V_{CC2} = 5.5\text{ V}$, $T_J = 150^\circ\text{C}$, $C_L = 15\text{ pF}$, input a 50 MHz 50% duty cycle square wave

PARAMETER		TEST CONDITIONS	MIN	TYP	MAX	UNIT
P_D	Maximum power dissipation by ISO7841x				200	mW
P_{D1}	Maximum power dissipation by side-1 of ISO7841x				50	mW
P_{D2}	Maximum power dissipation by side-2 of ISO7841x				150	mW

6.6 Insulation Specifications

PARAMETER		TEST CONDITIONS	SPECIFICATION		UNIT
			DW	DWW	
GENERAL					
CLR	External clearance ⁽¹⁾	Shortest pin-to-pin distance through air	>8	>14.5	mm
CPG	External creepage ⁽¹⁾	Shortest pin-to-pin distance across the package surface <i>High Voltage Feature Description</i>	>8	>14.5	mm
DTI	Distance through the insulation	Minimum internal gap (internal clearance)	>21	>21	μm
CTI	Comparative tracking index	DIN EN 60112 (VDE 0303-11); IEC 60112; UL 746A	>600	>600	V
	Material group		I	I	
	Overvoltage category per IEC 60664-1	Rated mains voltage ≤ 600 V _{RMS}	I–IV	I–IV	
		Rated mains voltage ≤ 1000 V _{RMS}	I–III	I–IV	
DIN V VDE V 0884-10 (VDE V 0884-10):2006-12⁽²⁾					
V _{IORM}	Maximum repetitive peak isolation voltage		2121	2828	V _{PK}
V _{IOWM}	Maximum isolation working voltage	AC voltage (sine wave); Time dependent dielectric breakdown (TDDb) Test, see Figure 1 and Figure 2	1500	2000	V _{RMS}
		DC voltage	2121	2828	V _{DC}
V _{IOTM}	Maximum transient isolation voltage	V _{TEST} = V _{IOTM} t = 60 s (qualification) t = 1 s (100% production)	8000	8000	V _{PK}
V _{IOSM}	Maximum surge isolation voltage ⁽³⁾	Test method per IEC 60065, 1.2/50 μs waveform, V _{TEST} = 1.6 × V _{IOSM} = 12800 V _{PK} (qualification)	8000	8000	V _{PK}
q _{pd}	Apparent charge ⁽⁴⁾	Method a: After I/O safety test subgroup 2/3, V _{ini} = V _{IOTM} , t _{ini} = 60 s; V _{pd(m)} = 1.2 × V _{IORM} = 2545 V _{PK} (DW) and 3394 V _{PK} (DWW), t _m = 10 s	≤5	≤5	pC
		Method a: After environmental tests subgroup 1, V _{ini} = V _{IOTM} , t _{ini} = 60 s; V _{pd(m)} = 1.6 × V _{IORM} = 3394 V _{PK} (DW) and 4525 V _{PK} (DWW), t _m = 10 s	≤5	≤5	
		Method b1: At routine test (100% production) and preconditioning (type test) V _{ini} = V _{IOTM} , t _{ini} = 1 s; V _{pd(m)} = 1.875 × V _{IORM} = 3977 V _{PK} (DW) and 5303 V _{PK} (DWW), t _m = 1 s	≤5	≤5	
C _{IO}	Barrier capacitance, input to output ⁽⁵⁾	V _{IO} = 0.4 × sin(2πft), f = 1 MHz	2	2	pF
R _{IO}	Isolation resistance, input to output ⁽⁵⁾	V _{IO} = 500 V, T _A = 25°C	>10 ¹²	>10 ¹²	Ω
		V _{IO} = 500 V, 100°C ≤ T _A ≤ 125°C	>10 ¹¹	>10 ¹¹	
		V _{IO} = 500 V at T _S = 150°C	>10 ⁹	>10 ⁹	
	Pollution degree		2	2	
	Climatic category		55/125/21	55/125/21	
UL 1577					
V _{ISO}	Withstand isolation voltage	V _{TEST} = V _{ISO} = 5700 V _{RMS} , t = 60 s (qualification), V _{TEST} = 1.2 × V _{ISO} = 6840 V _{RMS} , t = 1 s (100% production)	5700	5700	V _{RMS}

- (1) Creepage and clearance requirements should be applied according to the specific equipment isolation standards of an application. Care should be taken to maintain the creepage and clearance distance of a board design to ensure that the mounting pads of the isolator on the printed-circuit board do not reduce this distance. Creepage and clearance on a printed-circuit board become equal in certain cases. Techniques such as inserting grooves, ribs, or both on a printed circuit board are used to help increase these specifications.
- (2) This coupler is suitable for *safe electrical insulation* only within the safety ratings. Compliance with the safety ratings shall be ensured by means of suitable protective circuits.
- (3) Testing is carried out in air or oil to determine the intrinsic surge immunity of the isolation barrier.
- (4) Apparent charge is electrical discharge caused by a partial discharge (pd).
- (5) All pins on each side of the barrier tied together creating a two-pin device.

6.7 Safety-Related Certifications

Certifications for the DW package are complete. DWW package certifications are complete for UL, VDE and TUV and planned for CSA and CQC.

VDE	CSA	UL	CQC	TUV
Certified according to DIN V VDE V 0884-10 (VDE V 0884-10):2006-12 and DIN EN 60950-1 (VDE 0805 Teil 1):2011-01	Approved under CSA Component Acceptance Notice 5A, IEC 60950-1 and IEC 60601-1	Certified according to UL 1577 Component Recognition Program	Certified according to GB 4943.1-2011	Certified according to EN 61010-1:2010 (3rd Ed) and EN 60950-1:2006/A11:2009/A1:2010/A12:2011/A2:2013
Reinforced insulation Maximum transient isolation voltage, 8000 V _{PK} ; Maximum repetitive peak isolation voltage, 2121 V _{PK} (DW), 2828 V _{PK} (DWW); Maximum surge isolation voltage, 8000 V _{PK}	Reinforced insulation per CSA 60950-1-07+A1+A2 and IEC 60950-1 2nd Ed., 800 V _{RMS} (DW package) and 1450 V _{RMS} (DWW package) max working voltage (pollution degree 2, material group I); 2 MOPP (Means of Patient Protection) per CSA 60601-1:14 and IEC 60601-1 Ed. 3.1, 250 V _{RMS} (354 V _{PK}) max working voltage (DW package)	Single protection, 5700 V _{RMS}	Reinforced Insulation, Altitude ≤ 5000 m, Tropical Climate, 250 V _{RMS} maximum working voltage	5700 V _{RMS} Reinforced insulation per EN 61010-1:2010 (3rd Ed) up to working voltage of 600 V _{RMS} (DW package) and 1000 V _{RMS} (DWW package) 5700 V _{RMS} Reinforced insulation per EN 60950-1:2006/A11:2009/A1:2010/A12:2011/A2:2013 up to working voltage of 800 V _{RMS} (DW package) and 1450 V _{RMS} (DWW package)
Certificate number: 40040142	Master contract number: 220991	File number: E181974	Certificate number: CQC15001121716	Client ID number: 77311

6.8 Safety Limiting Values

Safety limiting intends to minimize potential damage to the isolation barrier upon failure of input or output circuitry. A failure of the I/O can allow low resistance to ground or the supply and, without current limiting, dissipate sufficient power to overheat the die and damage the isolation barrier potentially leading to secondary system failures.

PARAMETER		TEST CONDITIONS	MIN	TYP	MAX	UNIT
I _S	Safety input, output, or supply current	R _{θJA} = 78.9°C/W, V _I = 5.5 V, T _J = 150°C, T _A = 25°C			288	mA
		R _{θJA} = 78.9°C/W, V _I = 3.6 V, T _J = 150°C, T _A = 25°C			440	
		R _{θJA} = 78.9°C/W, V _I = 2.75 V, T _J = 150°C, T _A = 25°C			576	
P _S	Safety input, output, or total power	R _{θJA} = 78.9°C/W, T _J = 150°C, T _A = 25°C			1584	mW
T _S	Maximum safety temperature				150	°C

The maximum safety temperature is the maximum junction temperature specified for the device. The power dissipation and junction-to-air thermal impedance of the device installed in the application hardware determines the junction temperature. The assumed junction-to-air thermal resistance in the [Thermal Information](#) is that of a device installed on a high-K test board for leaded surface-mount packages. The power is the recommended maximum input voltage times the current. The junction temperature is then the ambient temperature plus the power times the junction-to-air thermal resistance.

6.9 Electrical Characteristics—5-V Supply

 $V_{CC1} = V_{CC2} = 5\text{ V} \pm 10\%$ (over recommended operating conditions unless otherwise noted)

PARAMETER	TEST CONDITIONS	MIN	TYP	MAX	UNIT
V_{OH}	High-level output voltage $I_{OH} = -4\text{ mA}$; see Figure 11	$V_{CCO}^{(1)} - 0.4$	$V_{CCO}^{(1)} - 0.2$		V
V_{OL}	Low-level output voltage $I_{OL} = 4\text{ mA}$; see Figure 11		0.2	0.4	V
$V_{I(HYS)}$	Input threshold voltage hysteresis	$0.1 \times V_{CCI}^{(1)}$			V
I_{IH}	High-level input current $V_{IH} = V_{CCI}^{(1)}$ at INx or ENx			10	μA
I_{IL}	Low-level input current $V_{IL} = 0\text{ V}$ at INx or ENx	-10			μA
CMTI	Common-mode transient immunity $V_I = V_{CCI}^{(1)}$ or 0 V, $V_{CM} = 1500\text{ V}$; see Figure 14	100			kV/ μs
C_I	Input capacitance $V_I = V_{CC}/2 + 0.4 \times \sin(2\pi ft)$, $f = 1\text{ MHz}$, $V_{CC} = 5\text{ V}$		2		pF

 (1) V_{CCI} = Input-side V_{CC} ; V_{CCO} = Output-side V_{CC} .

6.10 Supply Current Characteristics—5-V Supply

 $V_{CC1} = V_{CC2} = 5\text{ V} \pm 10\%$ (over recommended operating conditions unless otherwise noted)

PARAMETER	TEST CONDITIONS	SUPPLY CURRENT	MIN	TYP	MAX	UNIT
ISO7841DW AND ISO7841FDW						
Supply current	Disable	EN1 = EN2 = 0 V, $V_I = 0\text{ V}$ (ISO7841F), $V_I = V_{CCI}^{(1)}$ (ISO7841)	I_{CC1}	1.1	1.8	mA
			I_{CC2}	0.8	1.3	
		$V_I = 0\text{ V}$ (ISO7841F), $V_I = V_{CCI}^{(1)}$ (ISO7841)	I_{CC1}	4.5	6.6	mA
			I_{CC2}	2	2.9	
	DC signal	$V_I = 0\text{ V}$ (ISO7841F), $V_I = V_{CCI}^{(1)}$ (ISO7841)	I_{CC1}	1.5	2.4	mA
			I_{CC2}	2.1	3.1	
		$V_I = V_{CCI}^{(1)}$ (ISO7841F), $V_I = 0\text{ V}$ (ISO7841)	I_{CC1}	5	7.3	mA
			I_{CC2}	3.4	4.9	
	All channels switching with square wave clock input; $C_L = 15\text{ pF}$	1 Mbps	I_{CC1}	3.3	4.9	mA
			I_{CC2}	2.9	4.2	
		10 Mbps	I_{CC1}	3.9	5.5	mA
			I_{CC2}	4.4	5.7	
100 Mbps		I_{CC1}	9.2	11.6	mA	
		I_{CC2}	19	21.9		
ISO7841DWW AND ISO7841FDWW						
Supply current	Disable	EN1 = EN2 = 0 V, $V_I = 0\text{ V}$ (ISO7841F), $V_I = V_{CCI}^{(1)}$ (ISO7841)	I_{CC1}	1.1	1.8	mA
			I_{CC2}	0.8	1.3	
		$V_I = 0\text{ V}$ (ISO7841F), $V_I = V_{CCI}^{(1)}$ (ISO7841)	I_{CC1}	4.5	6.6	mA
			I_{CC2}	2	2.9	
	DC signal	$V_I = 0\text{ V}$ (ISO7841F), $V_I = V_{CCI}^{(1)}$ (ISO7841)	I_{CC1}	1.5	2.4	mA
			I_{CC2}	2.1	3.3	
		$V_I = V_{CCI}^{(1)}$ (ISO7841F), $V_I = 0\text{ V}$ (ISO7841)	I_{CC1}	5	7.5	mA
			I_{CC2}	3.4	5.2	
	All channels switching with square wave clock input; $C_L = 15\text{ pF}$	1 Mbps	I_{CC1}	3.4	5	mA
			I_{CC2}	3	4.4	
		10 Mbps	I_{CC1}	4	5.6	mA
			I_{CC2}	4.5	6.1	
100 Mbps		I_{CC1}	9.4	12.1	mA	
		I_{CC2}	19.5	22.6		

 (1) V_{CCI} = Input-side V_{CC} ; V_{CCO} = Output-side V_{CC} .

6.11 Electrical Characteristics—3.3-V Supply

 $V_{CC1} = V_{CC2} = 3.3\text{ V} \pm 10\%$ (over recommended operating conditions unless otherwise noted)

PARAMETER	TEST CONDITIONS	MIN	TYP	MAX	UNIT
V_{OH}	High-level output voltage	$I_{OH} = -2\text{ mA}$; see Figure 11	$V_{CCO}^{(1)} - 0.4$	$V_{CCO}^{(1)} - 0.2$	V
V_{OL}	Low-level output voltage	$I_{OL} = 2\text{ mA}$; see Figure 11	0.2	0.4	V
$V_{I(HYS)}$	Input threshold voltage hysteresis		$0.1 \times V_{CCI}^{(1)}$		V
I_{IH}	High-level input current	$V_{IH} = V_{CCI}^{(1)}$ at INx or ENx		10	μA
I_{IL}	Low-level input current	$V_{IL} = 0\text{ V}$ at INx or ENx	-10		μA
CMTI	Common-mode transient immunity	$V_I = V_{CCI}^{(1)}$ or 0 V, $V_{CM} = 1500\text{ V}$; see Figure 14	100		$\text{kV}/\mu\text{s}$

(1) V_{CCI} = Input-side V_{CC} ; V_{CCO} = Output-side V_{CC} .

6.12 Electrical Characteristics—3.3-V Supply

 $V_{CC1} = V_{CC2} = 3.3\text{ V} \pm 10\%$ (over recommended operating conditions unless otherwise noted)

PARAMETER	TEST CONDITIONS	SUPPLY CURRENT	MIN	TYP	MAX	UNIT
ISO7841DW AND ISO7841FDW						
Supply current	Disable	$EN1 = EN2 = 0\text{ V}$, $V_I = 0\text{ V}$ (ISO7841F), $V_I = V_{CCI}^{(1)}$ (ISO7841)	I_{CC1}	1.1	1.8	mA
			I_{CC2}	0.8	1.3	
		$EN1 = EN2 = 0\text{ V}$, $V_I = V_{CCI}^{(1)}$ (ISO7841F), $V_I = 0\text{ V}$ (ISO7841)	I_{CC1}	4.5	6.6	mA
			I_{CC2}	1.9	2.9	
	DC signal	$V_I = 0\text{ V}$ (ISO7841F), $V_I = V_{CCI}^{(1)}$ (ISO7841)	I_{CC1}	1.5	2.4	mA
			I_{CC2}	2.1	3.1	
		$V_I = V_{CCI}^{(1)}$ (ISO7841F), $V_I = 0\text{ V}$ (ISO7841)	I_{CC1}	5	7.3	mA
			I_{CC2}	3.3	4.9	
	All channels switching with square wave clock input; $C_L = 15\text{ pF}$	1 Mbps	I_{CC1}	3.3	4.9	mA
			I_{CC2}	2.8	4.1	
		10 Mbps	I_{CC1}	3.7	5.3	mA
			I_{CC2}	3.9	5.2	
100 Mbps		I_{CC1}	7.4	9.3	mA	
		I_{CC2}	14.5	16.9		
ISO7841DWW AND ISO7841FDWW						
Supply current	Disable	$EN1 = EN2 = 0\text{ V}$, $V_I = 0\text{ V}$ (ISO7841F), $V_I = V_{CCI}^{(1)}$ (ISO7841)	I_{CC1}	1.1	1.8	mA
			I_{CC2}	0.8	1.3	
		$EN1 = EN2 = 0\text{ V}$, $V_I = V_{CCI}^{(1)}$ (ISO7841F), $V_I = 0\text{ V}$ (ISO7841)	I_{CC1}	4.5	6.6	mA
			I_{CC2}	2	2.9	
	DC signal	$V_I = 0\text{ V}$ (ISO7841F), $V_I = V_{CCI}^{(1)}$ (ISO7841)	I_{CC1}	1.5	2.4	mA
			I_{CC2}	2.1	3.3	
		$V_I = V_{CCI}^{(1)}$ (ISO7841F), $V_I = 0\text{ V}$ (ISO7841)	I_{CC1}	5	7.5	mA
			I_{CC2}	3.4	5.2	
	All channels switching with square wave clock input; $C_L = 15\text{ pF}$	1 Mbps	I_{CC1}	3.4	5	mA
			I_{CC2}	2.9	4.4	
		10 Mbps	I_{CC1}	3.8	5.4	mA
			I_{CC2}	4	5.5	
100 Mbps		I_{CC1}	7.5	9.9	mA	
		I_{CC2}	14.8	17.2		

(1) V_{CCI} = Input-side V_{CC} ; V_{CCO} = Output-side V_{CC} .

6.13 Electrical Characteristics—2.5-V Supply

 $V_{CC1} = V_{CC2} = 2.5\text{ V} \pm 10\%$ (over recommended operating conditions unless otherwise noted)

PARAMETER	TEST CONDITIONS	MIN	TYP	MAX	UNIT
V_{OH}	High-level output voltage $I_{OH} = -1\text{ mA}$; see Figure 11	$V_{CCO}^{(1)} - 0.4$	$V_{CCO}^{(1)} - 0.2$		V
V_{OL}	Low-level output voltage $I_{OL} = 1\text{ mA}$; see Figure 11		0.2	0.4	V
$V_{I(HYS)}$	Input threshold voltage hysteresis	$0.1 \times V_{CCI}^{(1)}$			V
I_{IH}	High-level input current $V_{IH} = V_{CCI}^{(1)}$ at INx or ENx			10	μA
I_{IL}	Low-level input current $V_{IL} = 0\text{ V}$ at INx or ENx	-10			μA
CMTI	Common-mode transient immunity $V_I = V_{CCI}^{(1)}$ or 0 V , $V_{CM} = 1500\text{ V}$; see Figure 14	100			kV/ μs

 (1) V_{CCI} = Input-side V_{CC} ; V_{CCO} = Output-side V_{CC} .

6.14 Supply Current Characteristics—2.5-V Supply

 $V_{CC1} = V_{CC2} = 2.5\text{ V} \pm 10\%$ (over recommended operating conditions unless otherwise noted)

PARAMETER	TEST CONDITIONS	SUPPLY CURRENT	MIN	TYP	MAX	UNIT
ISO7841DW AND ISO7841FDW						
Supply current	Disable	$EN1 = EN2 = 0\text{ V}$, $V_I = 0\text{ V}$ (ISO7841F), $V_I = V_{CCI}^{(1)}$ (ISO7841)	I_{CC1}	1.1	1.7	mA
			I_{CC2}	0.8	1.2	
		$EN1 = EN2 = 0\text{ V}$, $V_I = V_{CCI}^{(1)}$ (ISO7841F), $V_I = 0\text{ V}$ (ISO7841)	I_{CC1}	4.5	6.5	mA
			I_{CC2}	1.9	2.8	
	DC signal	$V_I = 0\text{ V}$ (ISO7841F), $V_I = V_{CCI}^{(1)}$ (ISO7841)	I_{CC1}	1.6	2.3	mA
			I_{CC2}	2.2	3.1	
		$V_I = V_{CCI}^{(1)}$ (ISO7841F), $V_I = 0\text{ V}$ (ISO7841)	I_{CC1}	5.1	7.2	mA
			I_{CC2}	3.5	4.8	
	All channels switching with square wave clock input; $C_L = 15\text{ pF}$	1 Mbps	I_{CC1}	3.4	4.8	mA
			I_{CC2}	2.9	4	
		10 Mbps	I_{CC1}	3.7	5.1	mA
			I_{CC2}	3.7	4.8	
100 Mbps		I_{CC1}	6.8	8.1	mA	
		I_{CC2}	12	14.2		
ISO7841DWW AND ISO7841FDWW						
Supply current	Disable	$EN1 = EN2 = 0\text{ V}$, $V_I = 0\text{ V}$ (ISO7841F), $V_I = V_{CCI}^{(1)}$ (ISO7841)	I_{CC1}	1.1	1.7	mA
			I_{CC2}	0.8	1.2	
		$EN1 = EN2 = 0\text{ V}$, $V_I = V_{CCI}^{(1)}$ (ISO7841F), $V_I = 0\text{ V}$ (ISO7841)	I_{CC1}	4.5	6.5	mA
			I_{CC2}	1.9	2.8	
	DC signal	$V_I = 0\text{ V}$ (ISO7841F), $V_I = V_{CCI}^{(1)}$ (ISO7841)	I_{CC1}	1.6	2.4	mA
			I_{CC2}	2.2	3.3	
		$V_I = V_{CCI}^{(1)}$ (ISO7841F), $V_I = 0\text{ V}$ (ISO7841)	I_{CC1}	5.1	7.5	mA
			I_{CC2}	3.5	5.2	
	All channels switching with square wave clock input; $C_L = 15\text{ pF}$	1 Mbps	I_{CC1}	3.5	5	mA
			I_{CC2}	3	4.3	
		10 Mbps	I_{CC1}	3.8	5.3	mA
			I_{CC2}	3.8	5.2	
100 Mbps		I_{CC1}	6.9	8.8	mA	
		I_{CC2}	12.3	14.2		

 (1) V_{CCI} = Input-side V_{CC} ; V_{CCO} = Output-side V_{CC} .

6.15 Switching Characteristics—5-V Supply

 $V_{CC1} = V_{CC2} = 5\text{ V} \pm 10\%$ (over recommended operating conditions unless otherwise noted)

PARAMETER		TEST CONDITIONS	MIN	TYP	MAX	UNIT
t_{PLH} , t_{PHL}	Propagation delay time	See Figure 11	6	11	16	ns
PWD	Pulse width distortion ⁽¹⁾ $ t_{PHL} - t_{PLH} $		0.55	4.1	ns	
$t_{sk(o)}$	Channel-to-channel output skew time ⁽²⁾	Same-direction channels			2.5	ns
$t_{sk(pp)}$	Part-to-part skew time ⁽³⁾				4.5	ns
t_r	Output signal rise time	See Figure 11		1.7	3.9	ns
t_f	Output signal fall time			1.9	3.9	ns
t_{PHZ}	Disable propagation delay, high-to-high impedance output	See Figure 12		12	20	ns
t_{PLZ}	Disable propagation delay, low-to-high impedance output			12	20	ns
t_{PZH}	Enable propagation delay, high impedance-to-high output for ISO7841			10	20	ns
	Enable propagation delay, high impedance-to-high output for ISO7841F			2	2.5	μs
t_{PZL}	Enable propagation delay, high impedance-to-low output for ISO7841			2	2.5	μs
	Enable propagation delay, high impedance-to-low output for ISO7841F			10	20	ns
t_{is}	Default output delay time from input power loss	Measured from the time V_{CC} goes below 1.7 V. See Figure 13		0.2	9	μs
t_{ie}	Time interval error	$2^{16} - 1$ PRBS data at 100 Mbps		0.90		ns

- (1) Also known as pulse skew.
- (2) $t_{sk(o)}$ is the skew between outputs of a single device with all driving inputs connected together and the outputs switching in the same direction while driving identical loads.
- (3) $t_{sk(pp)}$ is the magnitude of the difference in propagation delay times between any terminals of different devices switching in the same direction while operating at identical supply voltages, temperature, input signals and loads.

6.16 Switching Characteristics—3.3-V Supply

 $V_{CC1} = V_{CC2} = 3.3\text{ V} \pm 10\%$ (over recommended operating conditions unless otherwise noted)

PARAMETER		TEST CONDITIONS	MIN	TYP	MAX	UNIT
t_{PLH} , t_{PHL}	Propagation delay time	See Figure 11	6	10.8	16	ns
PWD	Pulse width distortion ⁽¹⁾ $ t_{PHL} - t_{PLH} $		0.7	4.2	ns	
$t_{sk(o)}$	Channel-to-channel output skew time ⁽²⁾	Same-direction channels			2.2	ns
$t_{sk(pp)}$	Part-to-part skew time ⁽³⁾				4.5	ns
t_r	Output signal rise time	See Figure 11		0.8	3	ns
t_f	Output signal fall time			0.8	3	ns
t_{PHZ}	Disable propagation delay, high-to-high impedance output	See Figure 12		17	32	ns
t_{PLZ}	Disable propagation delay, low-to-high impedance output			17	32	ns
t_{PZH}	Enable propagation delay, high impedance-to-high output for ISO7841			17	32	ns
	Enable propagation delay, high impedance-to-high output for ISO7841F			2	2.5	μs
t_{PZL}	Enable propagation delay, high impedance-to-low output for ISO7841			2	2.5	μs
	Enable propagation delay, high impedance-to-low output for ISO7841F			17	32	ns
t_{is}	Default output delay time from input power loss	Measured from the time V_{CC} goes below 1.7 V. See Figure 13		0.2	9	μs
t_{ie}	Time interval error	$2^{16} - 1$ PRBS data at 100 Mbps		0.91		ns

- (1) Also known as Pulse Skew.
- (2) $t_{sk(o)}$ is the skew between outputs of a single device with all driving inputs connected together and the outputs switching in the same direction while driving identical loads.
- (3) $t_{sk(pp)}$ is the magnitude of the difference in propagation delay times between any terminals of different devices switching in the same direction while operating at identical supply voltages, temperature, input signals and loads.

6.17 Switching Characteristics—2.5-V Supply

 $V_{CC1} = V_{CC2} = 2.5 \text{ V} \pm 10\%$ (over recommended operating conditions unless otherwise noted)

PARAMETER		TEST CONDITIONS	MIN	TYP	MAX	UNIT
t_{PLH} , t_{PHL}	Propagation delay time	See Figure 11	7.5	11.7	17.5	ns
PWD	Pulse width distortion ⁽¹⁾ $ t_{PHL} - t_{PLH} $		0.66	4.2		ns
$t_{sk(o)}$	Channel-to-channel output skew time ⁽²⁾	Same-direction Channels			2.2	ns
$t_{sk(pp)}$	Part-to-part skew time ⁽³⁾				4.5	ns
t_r	Output signal rise time	See Figure 11		1	3.5	ns
t_f	Output signal fall time			1.2	3.5	ns
t_{PHZ}	Disable propagation delay, high-to-high impedance output	See Figure 12		22	45	ns
t_{PLZ}	Disable propagation delay, low-to-high impedance output			22	45	ns
t_{PZH}	Enable propagation delay, high impedance-to-high output for ISO7841			18	45	ns
	Enable propagation delay, high impedance-to-high output for ISO7841F			2	2.5	μs
t_{PZL}	Enable propagation delay, high impedance-to-low output for ISO7841			2	2.5	μs
	Enable propagation delay, high impedance-to-low output for ISO7841F			18	45	ns
t_{fs}	Default output delay time from input power loss	Measured from the time V_{CC} goes below 1.7 V. See Figure 13		0.2	9	μs
t_{ie}	Time interval error	$2^{16} - 1$ PRBS data at 100 Mbps		0.91		ns

(1) Also known as pulse skew.

(2) $t_{sk(o)}$ is the skew between outputs of a single device with all driving inputs connected together and the outputs switching in the same direction while driving identical loads.

(3) $t_{sk(pp)}$ is the magnitude of the difference in propagation delay times between any terminals of different devices switching in the same direction while operating at identical supply voltages, temperature, input signals and loads.

6.18 Insulation Characteristics Curves

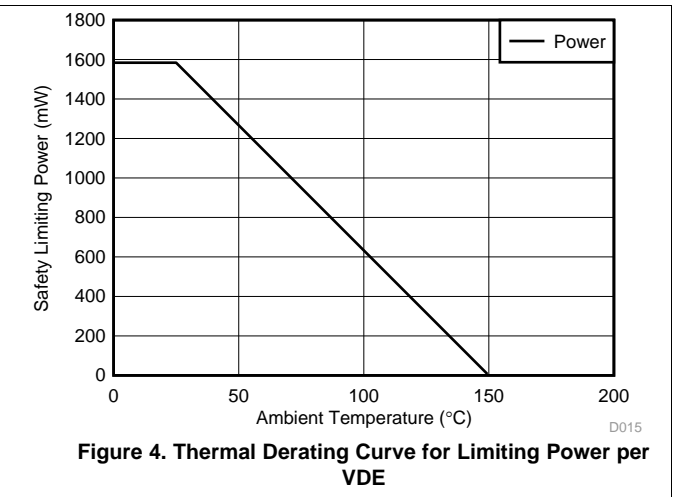
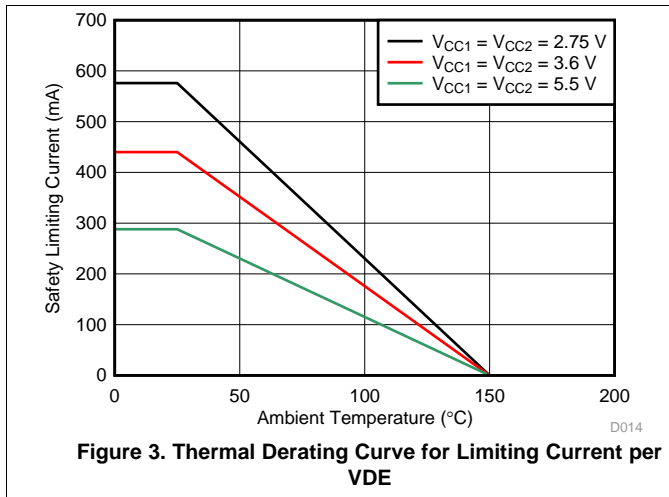
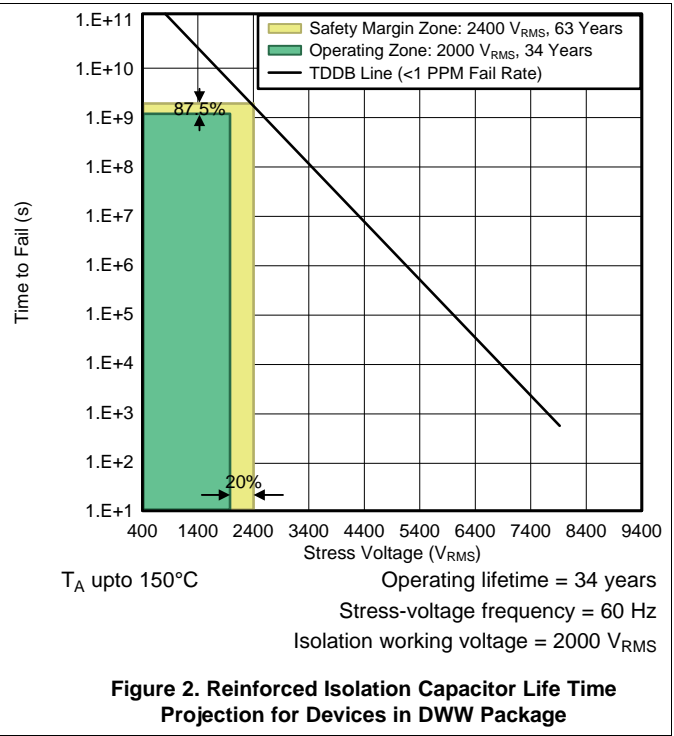
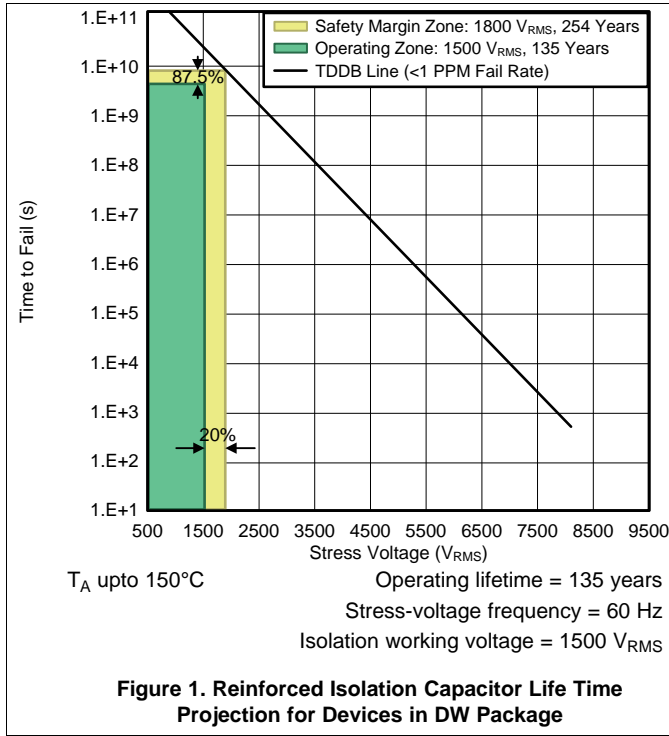

6.19 Typical Characteristics

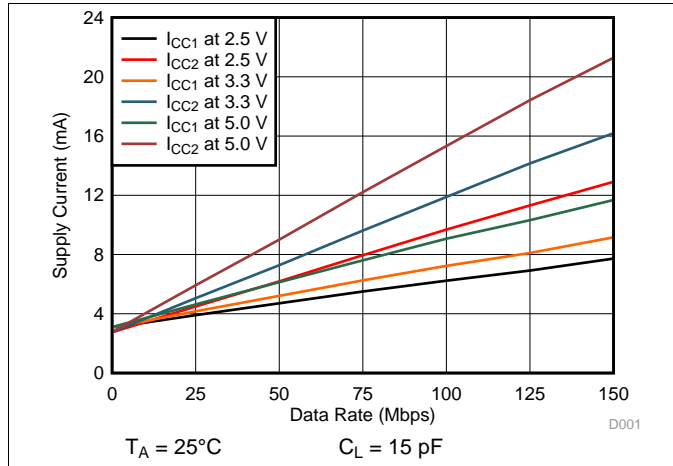

Figure 5. Supply Current vs Data Rate (With 15-pF Load)

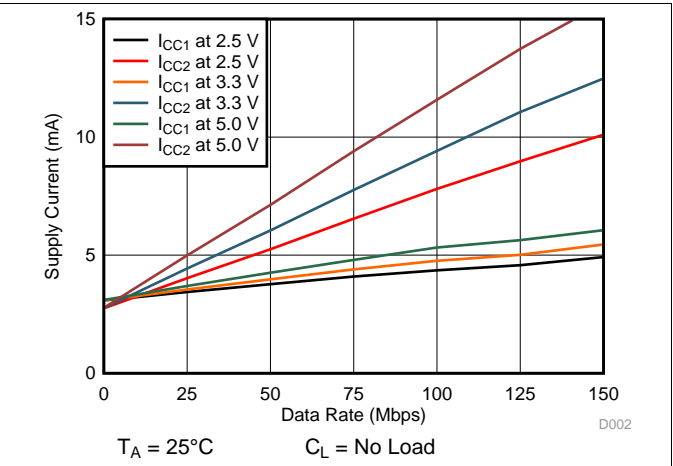

Figure 6. Supply Current vs Data Rate (With No Load)

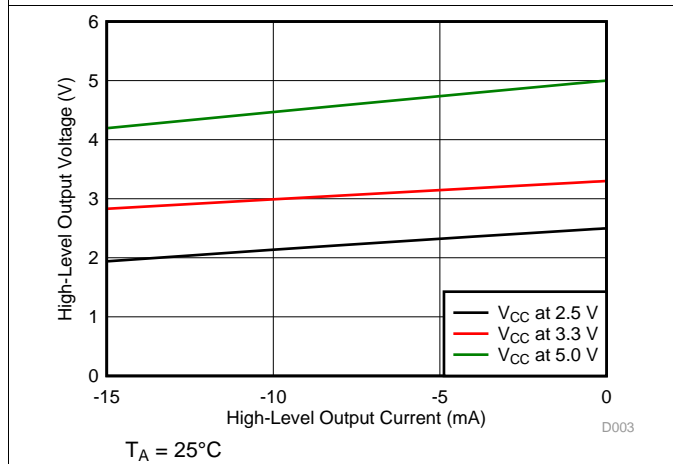

Figure 7. High-Level Output Voltage vs High-level Output Current

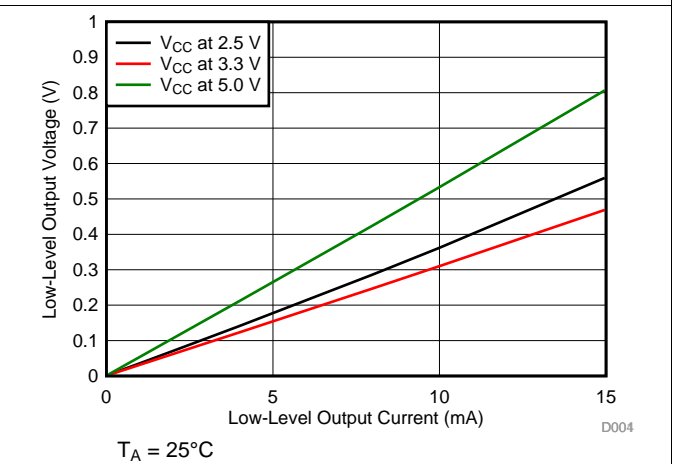

Figure 8. Low-Level Output Voltage vs Low-Level Output Current

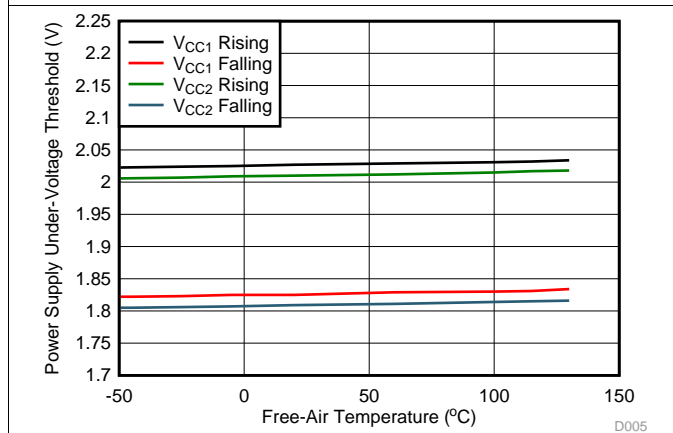

Figure 9. Power Supply Undervoltage Threshold vs Free-Air Temperature

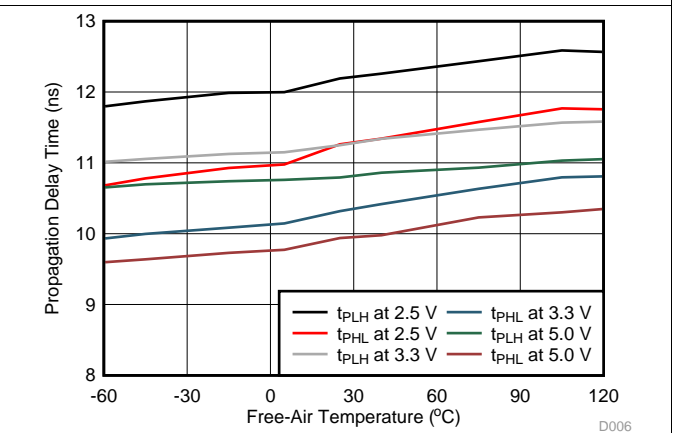
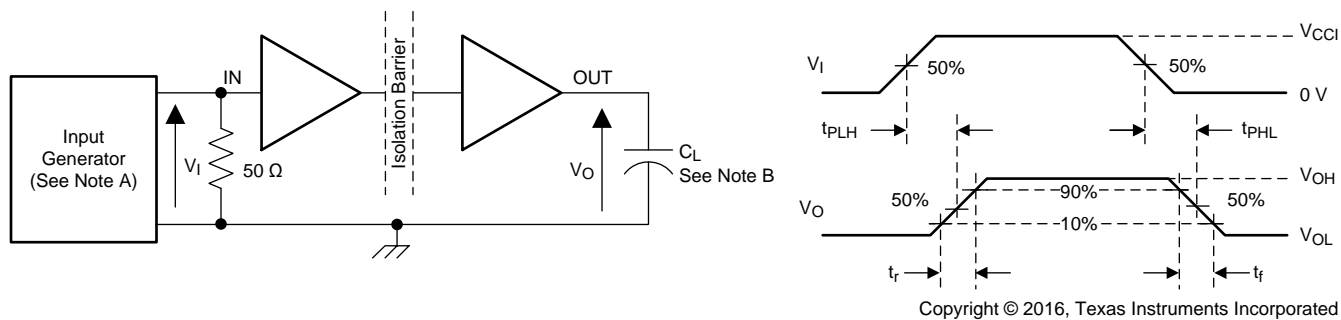

Figure 10. Propagation Delay Time vs Free-Air Temperature

7 Parameter Measurement Information



- A. The input pulse is supplied by a generator having the following characteristics: PRR \leq 50 kHz, 50% duty cycle, $t_r \leq 3$ ns, $t_f \leq 3$ ns, $Z_O = 50 \Omega$. At the input, 50Ω resistor is required to terminate Input Generator signal. It is not needed in actual application.
- B. $C_L = 15$ pF and includes instrumentation and fixture capacitance within $\pm 20\%$.

Figure 11. Switching Characteristics Test Circuit and Voltage Waveforms

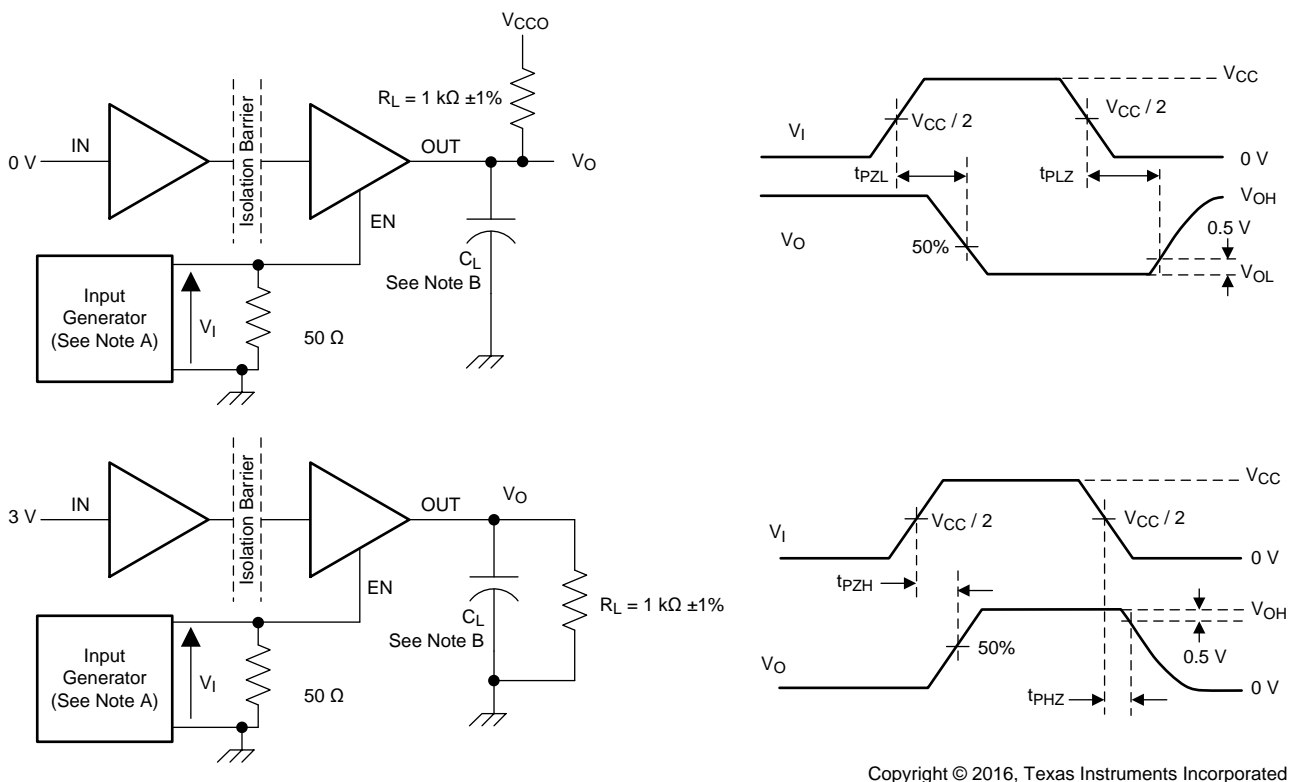

- A. The input pulse is supplied by a generator having the following characteristics: PRR \leq 10 kHz, 50% duty cycle, $t_r \leq 3$ ns, $t_f \leq 3$ ns, $Z_O = 50 \Omega$.
- B. $C_L = 15$ pF and includes instrumentation and fixture capacitance within $\pm 20\%$.

Figure 12. Enable/Disable Propagation Delay Time Test Circuit and Waveform

Parameter Measurement Information (continued)

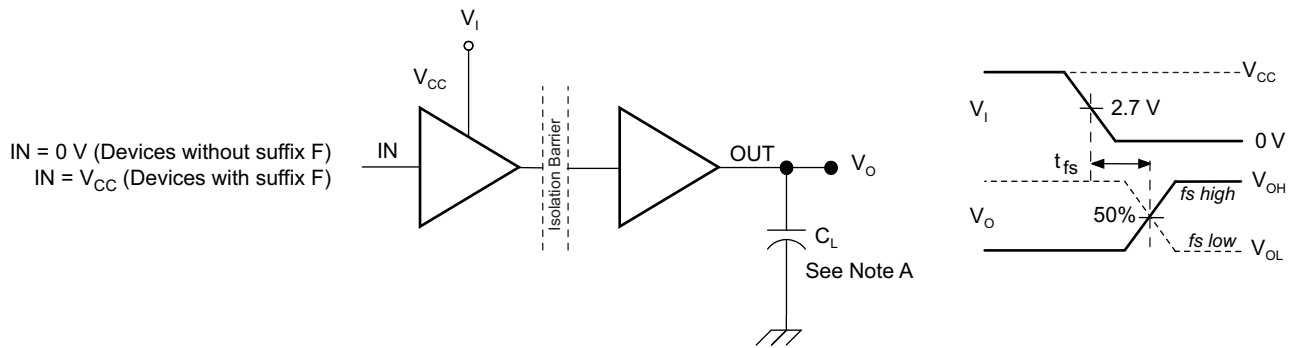

- A. C_L = 15 pF and includes instrumentation and fixture capacitance within ±20%.

Figure 13. Default Output Delay Time Test Circuit and Voltage Waveforms

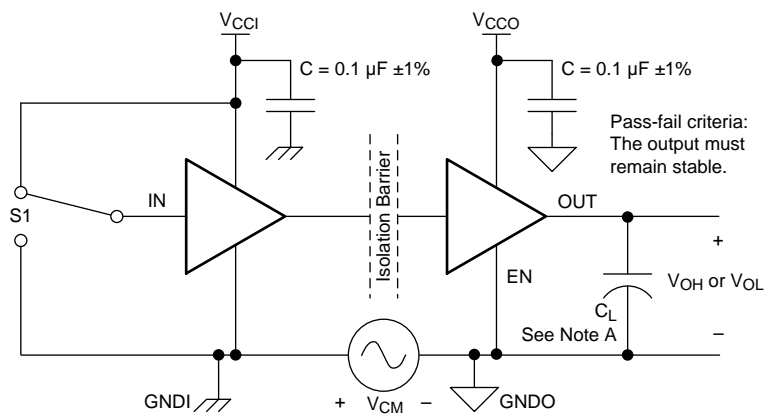

- A. C_L = 15 pF and includes instrumentation and fixture capacitance within ±20%.

Figure 14. Common-Mode Transient Immunity Test Circuit

8 Detailed Description

8.1 Overview

The ISO7841 device uses an ON-OFF keying (OOK) modulation scheme to transmit the digital data across a silicon-dioxide based isolation barrier. The transmitter sends a high-frequency carrier across the barrier to represent one digital state and sends no signal to represent the other digital state. The receiver demodulates the signal after advanced signal conditioning and produces the output through a buffer stage. If the EN pin is low then the output goes to high impedance. The ISO7841 device also incorporates advanced circuit techniques to maximize the CMTI performance and minimize the radiated emissions because of the high-frequency carrier and IO buffer switching. The conceptual block diagram of a digital capacitive isolator, [Figure 15](#), shows a functional block diagram of a typical channel.

8.2 Functional Block Diagram

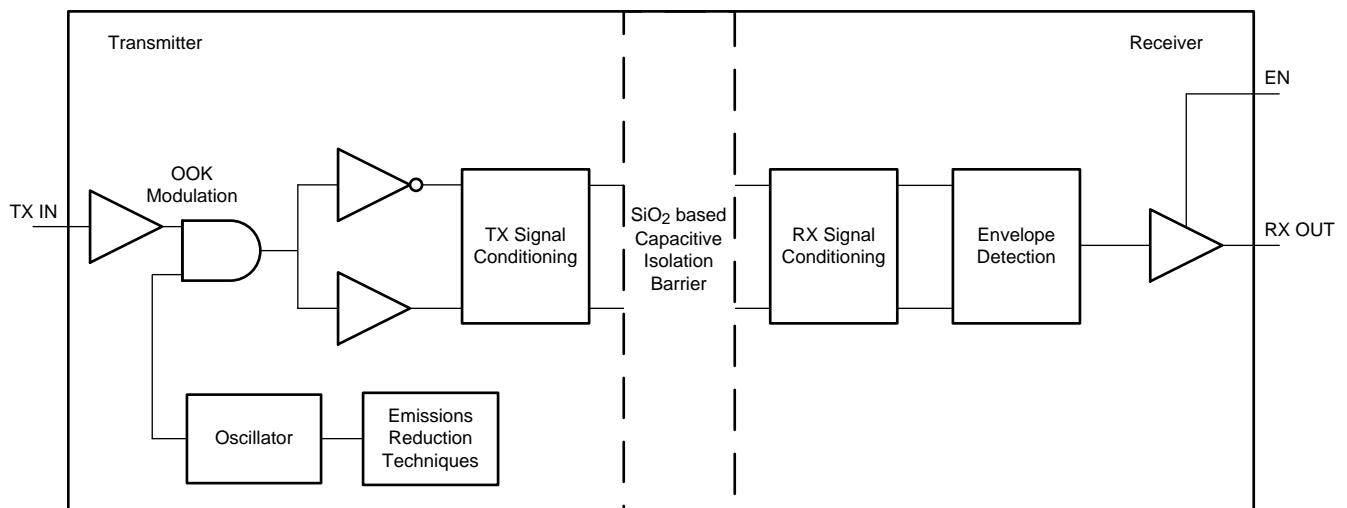

Copyright © 2016, Texas Instruments Incorporated

Figure 15. Conceptual Block Diagram of a Digital Capacitive Isolator

[Figure 16](#) shows a conceptual detail of how the ON-OFF keying scheme works.

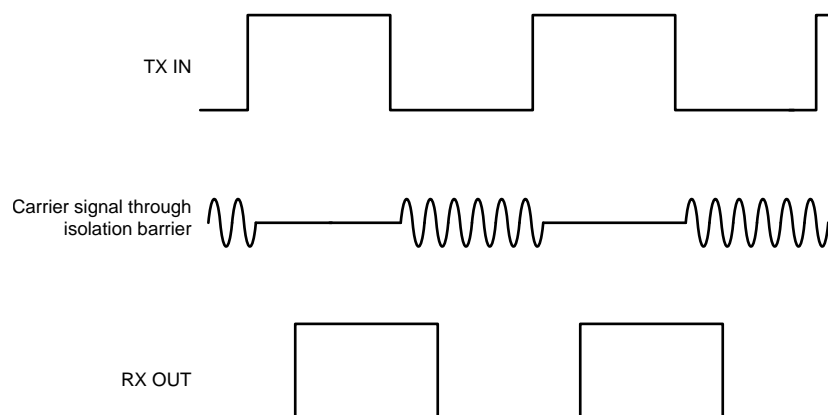

Figure 16. On-Off Keying (OOK) Based Modulation Scheme

8.3 Feature Description

Table 1 lists the device features.

Table 1. Device Features

PART NUMBER	CHANNEL DIRECTION	RATED ISOLATION	MAXIMUM DATA RATE	DEFAULT OUTPUT
ISO7841	3 Forward,	5700 V _{RMS} / 8000 V _{PK} ⁽¹⁾	100 Mbps	High
	1 Reverse			
ISO7841F	3 Forward,	5700 V _{RMS} / 8000 V _{PK} ⁽¹⁾	100 Mbps	Low
	1 Reverse			

(1) See for detailed isolation ratings.

8.3.1 Electromagnetic Compatibility (EMC) Considerations

Many applications in harsh industrial environment are sensitive to disturbances such as electrostatic discharge (ESD), electrical fast transient (EFT), surge, and electromagnetic emissions. These electromagnetic disturbances are regulated by international standards such as IEC 61000-4-x and CISPR 22. Although system-level performance and reliability depends, to a large extent, on the application board design and layout, the ISO7841 device incorporates many chip-level design improvements for overall system robustness. Some of these improvements include

- Robust ESD protection cells for input and output signal pins and inter-chip bond pads.
- Low-resistance connectivity of ESD cells to supply and ground pins.
- Enhanced performance of high voltage isolation capacitor for better tolerance of ESD, EFT and surge events.
- Bigger on-chip decoupling capacitors to bypass undesirable high energy signals through a low impedance path.
- PMOS and NMOS devices isolated from each other by using guard rings to avoid triggering of parasitic SCRs.
- Reduced common mode currents across the isolation barrier by ensuring purely differential internal operation.

8.4 Device Functional Modes

Table 2 lists the ISO7841 functional modes.

Table 2. Function Table⁽¹⁾

V _{CCI}	V _{CCO}	INPUT (IN _x) ⁽²⁾	OUTPUT ENABLE (EN _x)	OUTPUT (OUT _x)	COMMENTS
PU	PU	H	H or open	H	Normal Operation: A channel output assumes the logic state of its input.
		L	H or open	L	
		Open	H or open	Default	Default mode: When IN _x is open, the corresponding channel output goes to its default logic state. Default= High for ISO7841 and Low for ISO7841F.
X	PU	X	L	Z	A low value of Output Enable causes the outputs to be high-impedance
PD	PU	X	H or open	Default	Default mode: When V _{CCI} is unpowered, a channel output assumes the logic state based on the selected default option. Default= High for IISO7841 and Low for ISO7841F. When V _{CCI} transitions from unpowered to powered-up, a channel output assumes the logic state of its input. When V _{CCI} transitions from powered-up to unpowered, channel output assumes the selected default state.
X	PD	X	X	Undetermined	When V _{CCO} is unpowered, a channel output is undetermined ⁽³⁾ . When V _{CCO} transitions from unpowered to powered-up, a channel output assumes the logic state of its input

- (1) V_{CCI} = Input-side V_{CC}; V_{CCO} = Output-side V_{CC}; PU = Powered up (V_{CC} ≥ 2.25 V); PD = Powered down (V_{CC} ≤ 1.7 V); X = Irrelevant; H = High level; L = Low level ; Z = High Impedance
- (2) A strongly driven input signal can weakly power the floating V_{CC} through an internal protection diode and cause undetermined output.
- (3) The outputs are in undetermined state when 1.7 V < V_{CCI}, V_{CCO} < 2.25 V.

8.4.1 Device I/O Schematics

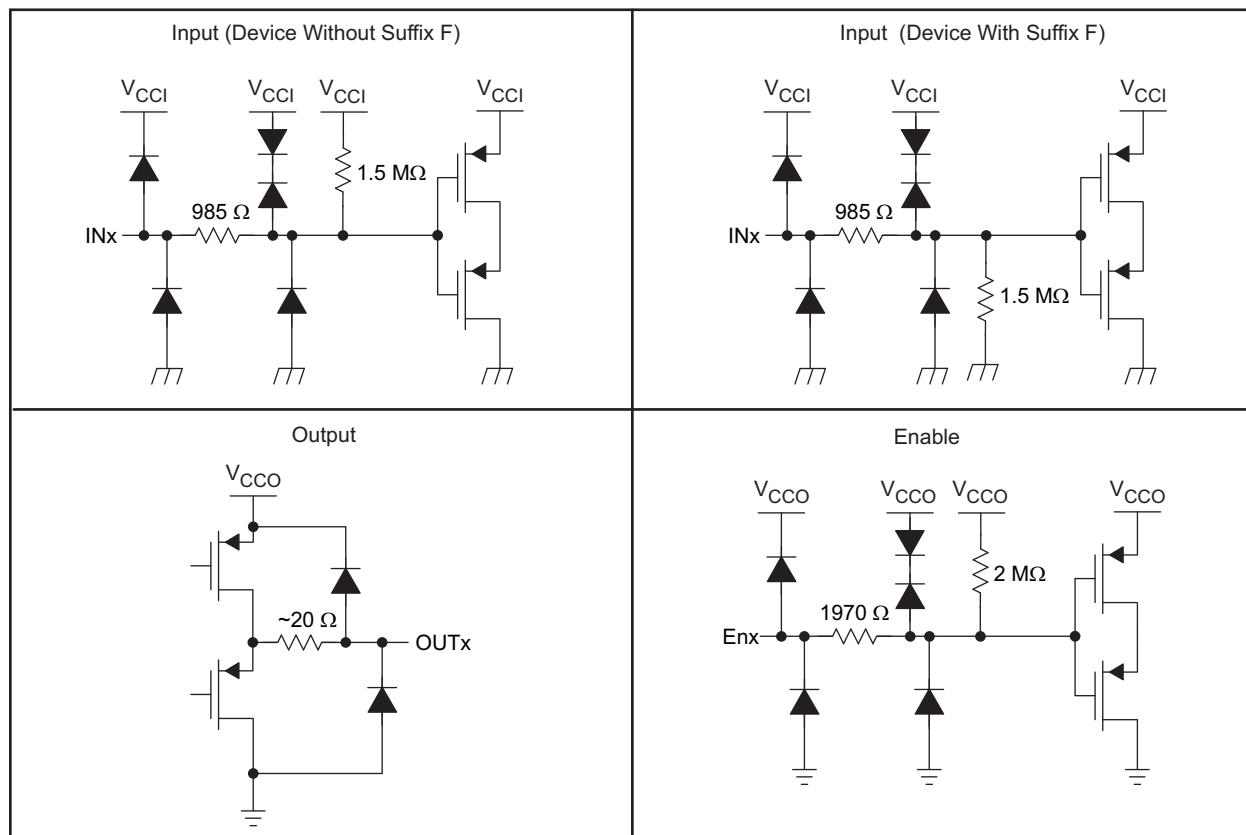

Copyright © 2016, Texas Instruments Incorporated

Figure 17. Device I/O Schematics

9 Application and Implementation

NOTE

Information in the following applications sections is not part of the TI component specification, and TI does not warrant its accuracy or completeness. TI's customers are responsible for determining suitability of components for their purposes. Customers should validate and test their design implementation to confirm system functionality.

9.1 Application Information

The ISO7841 device is a high-performance, quad-channel digital isolator with a 5.7-kV_{RMS} isolation voltage per UL 1577. The device comes with enable pins on each side that can be used to put the respective outputs in high impedance for multi-master driving applications and reduce power consumption. The ISO7841 device uses single-ended CMOS-logic switching technology. The supply voltage range is from 2.25 V to 5.5 V for both supplies, V_{CC1} and V_{CC2}. When designing with digital isolators, keep in mind that because of the single-ended design structure, digital isolators do not conform to any specific interface standard and are only intended for isolating single-ended CMOS or TTL digital signal lines. The isolator is typically placed between the data controller (that is, μ C or UART), and a data converter or a line transceiver, regardless of the interface type or standard.

9.2 Typical Application

Figure 18 shows the isolated SPI.

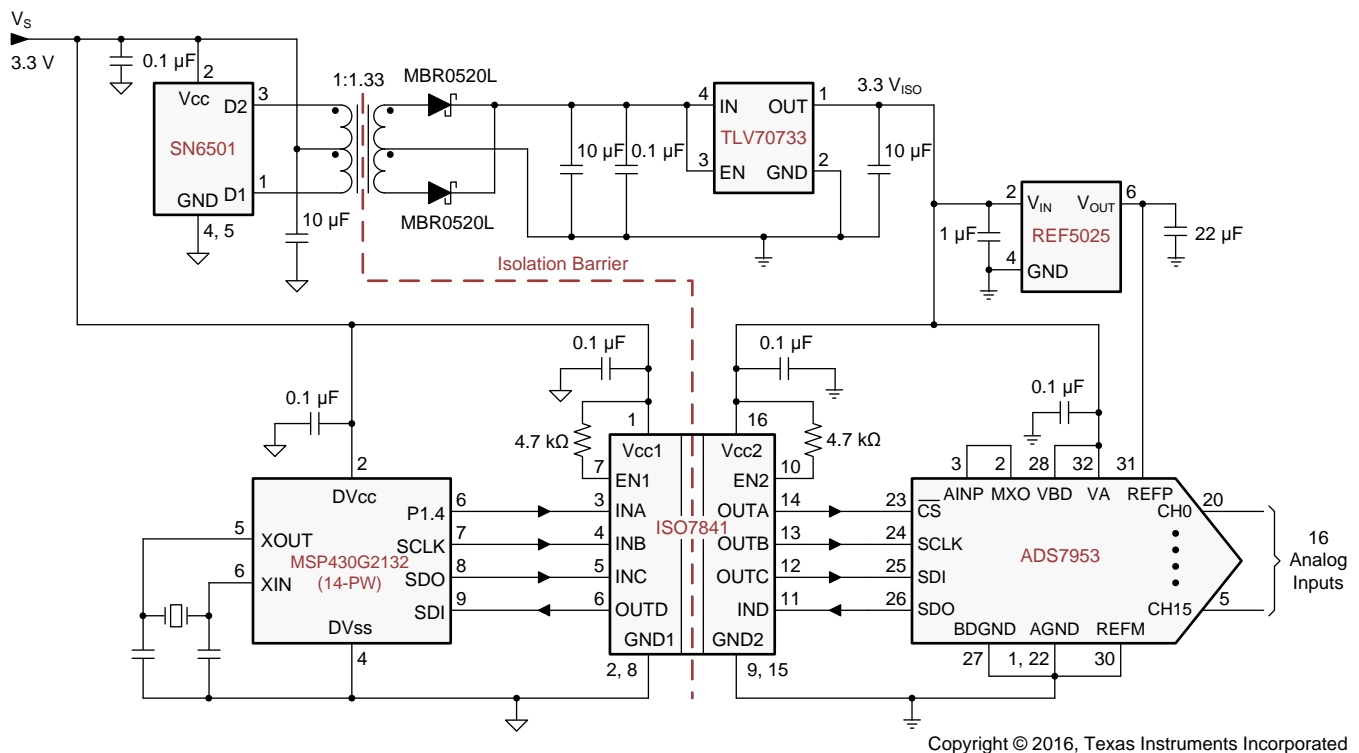

Figure 18. Isolated SPI for an Analog Input Module With 16 Input

Typical Application (continued)

9.2.1 Design Requirements

For this design example, use the parameters shown in [Table 3](#).

Table 3. Design Parameters

PARAMETER	VALUE
Supply voltage	2.25 to 5.5 V
Decoupling capacitor between V_{CC1} and GND1	0.1 μ F
Decoupling capacitor from V_{CC2} and GND2	0.1 μ F

9.2.2 Detailed Design Procedure

Unlike optocouplers, which require external components to improve performance, provide bias, or limit current, the ISO7841 device only requires two external bypass capacitors to operate.

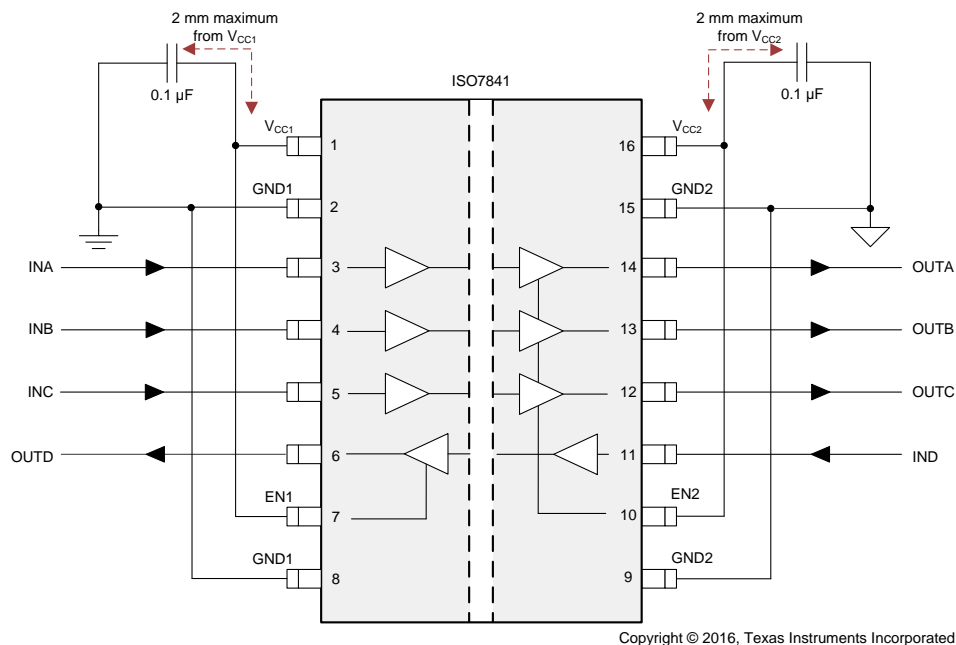

Figure 19. Typical ISO7841 Circuit Hook-Up

9.2.3 Application Curve

The typical eye diagram of the ISO7841 device indicates low jitter and wide open eye at the maximum data rate of 100 Mbps.

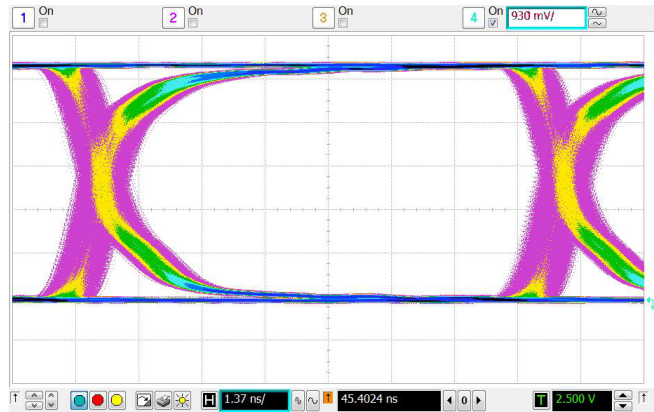

Figure 20. Eye Diagram at 100 Mbps PRBS, 5 V and 25°C

10 Power Supply Recommendations

To help ensure reliable operation at data rates and supply voltages, a 0.1- μ F bypass capacitor is recommended at input and output supply pins (V_{CC1} and V_{CC2}). The capacitors should be placed as close to the supply pins as possible. If only a single primary-side power supply is available in an application, isolated power can be generated for the secondary-side with the help of a transformer driver such as Texas Instruments [SN6501](#). For such applications, detailed power supply design and transformer selection recommendations are available in [SN6501 Transformer Driver for Isolated Power Supplies](#).

11 Layout

11.1 Layout Guidelines

A minimum of four layers is required to accomplish a low EMI PCB design (see [Figure 21](#)). Layer stacking should be in the following order (top-to-bottom): high-speed signal layer, ground plane, power plane and low-frequency signal layer.

- Routing the high-speed traces on the top layer avoids the use of vias (and the introduction of their inductances) and allows for clean interconnects between the isolator and the transmitter and receiver circuits of the data link.
- Placing a solid ground plane next to the high-speed signal layer establishes controlled impedance for transmission line interconnects and provides an excellent low-inductance path for the return current flow.
- Placing the power plane next to the ground plane creates additional high-frequency bypass capacitance of approximately 100 pF/inch².
- Routing the slower speed control signals on the bottom layer allows for greater flexibility as these signal links usually have margin to tolerate discontinuities such as vias.

If an additional supply voltage plane or signal layer is needed, add a second power or ground plane system to the stack to keep it symmetrical. This makes the stack mechanically stable and prevents it from warping. Also the power and ground plane of each power system can be placed closer together, thus increasing the high-frequency bypass capacitance significantly.

For detailed layout recommendations, refer to [Digital Isolator Design Guide](#).

11.1.1 PCB Material

For digital circuit boards operating at less than 150 Mbps, (or rise and fall times greater than 1 ns), and trace lengths of up to 10 inches, use standard FR-4 UL94V-0 printed circuit board. This PCB is preferred over cheaper alternatives because of lower dielectric losses at high frequencies, less moisture absorption, greater strength and stiffness, and the self-extinguishing flammability-characteristics.

11.2 Layout Example

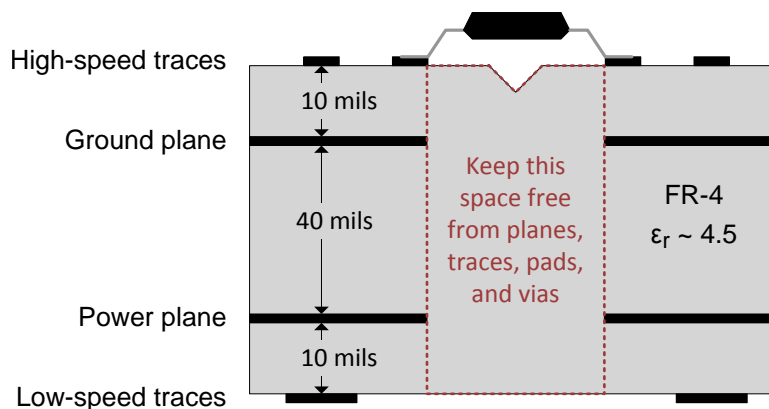

Figure 21. Layout Example Schematic

12 器件和文档支持

12.1 文档支持

12.1.1 相关文档

相关文档如下：

- [《ADS79xx- 8 位、10 位和 12 位，1MSPS，4 通道、8 通道、12 通道和 16 通道，单端，低功耗，串行接口 ADC》](#)
- [数字隔离器设计指南](#)
- [隔离相关术语](#)
- [《MSP430G2x32、MSP430G2x02 混合信号微控制器》](#)
- [《REF50xx 低噪声、极低漂移、高精度电压基准》](#)
- [《SN6501 用于隔离电源的变压器驱动器》](#)
- [《用于便携式设备的 TLV707、TLV707P 200mA、低 IQ、低噪声、低压降稳压器》](#)

12.2 相关链接

以下表格列出了快速访问链接。范围包括技术文档、支持与社区资源、工具和软件，并且可以快速访问样片或购买链接。

表 4. 相关链接

器件	产品文件夹	立即订购	技术文档	工具与软件	支持与社区
ISO7841	请单击此处	请单击此处	请单击此处	请单击此处	请单击此处
ISO7841F	请单击此处	请单击此处	请单击此处	请单击此处	请单击此处

12.3 接收文档更新通知

如需接收文档更新通知，请访问 www.ti.com.cn 网站上的器件产品文件夹。点击右上角的**提醒我 (Alert me)** 注册后，即可每周定期收到已更改的产品信息。有关更改的详细信息，请查阅已修订文档中包含的修订历史记录。

12.4 社区资源

The following links connect to TI community resources. Linked contents are provided "AS IS" by the respective contributors. They do not constitute TI specifications and do not necessarily reflect TI's views; see TI's [Terms of Use](#).

TI E2E™ Online Community *TI's Engineer-to-Engineer (E2E) Community*. Created to foster collaboration among engineers. At e2e.ti.com, you can ask questions, share knowledge, explore ideas and help solve problems with fellow engineers.

Design Support *TI's Design Support* Quickly find helpful E2E forums along with design support tools and contact information for technical support.

12.5 商标

E2E is a trademark of Texas Instruments.
All other trademarks are the property of their respective owners.

12.6 静电放电警告



这些装置包含有限的内置 ESD 保护。存储或装卸时，应将导线一起截短或将装置放置于导电泡棉中，以防止 MOS 门极遭受静电损伤。

12.7 Glossary

[SLYZ022](#) — *TI Glossary*.

This glossary lists and explains terms, acronyms, and definitions.

13 机械、封装和可订购信息

以下页中包括机械、封装和可订购信息。这些信息是针对指定器件可提供的最新数据。这些数据会在无通知且不对本文档进行修订的情况下发生改变。欲获得该数据表的浏览器版本，请查阅左侧的导航栏。

DW0016B
PACKAGE OUTLINE
SOIC - 2.65 mm max height

SOIC

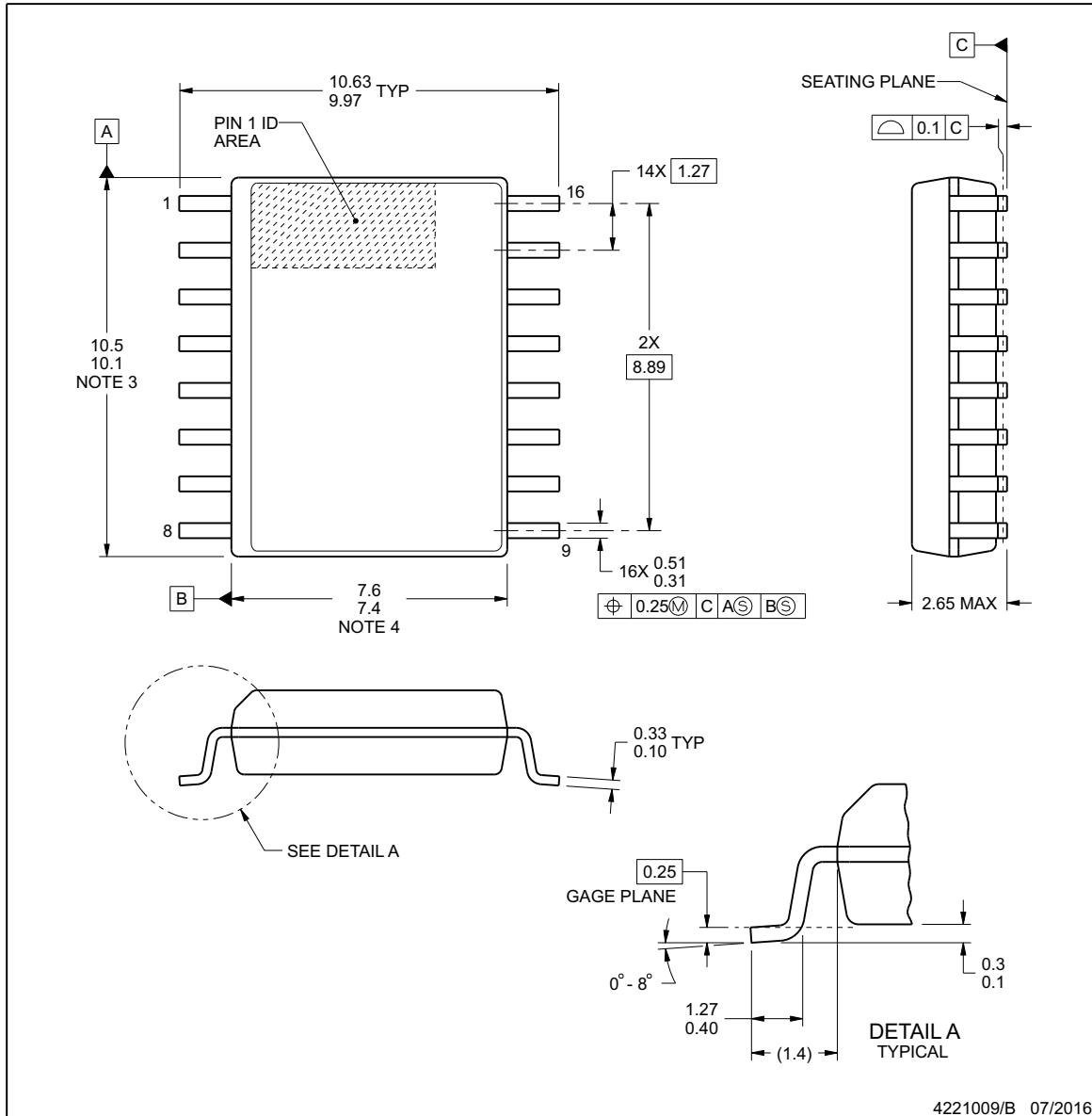

4221009/B 07/2016

NOTES:

1. All linear dimensions are in millimeters. Dimensions in parenthesis are for reference only. Dimensioning and tolerancing per ASME Y14.5M.
2. This drawing is subject to change without notice.
3. This dimension does not include mold flash, protrusions, or gate burrs. Mold flash, protrusions, or gate burrs shall not exceed 0.15 mm, per side.
4. This dimension does not include interlead flash. Interlead flash shall not exceed 0.25 mm, per side.
5. Reference JEDEC registration MS-013.

EXAMPLE BOARD LAYOUT

DW0016B

SOIC - 2.65 mm max height

SOIC

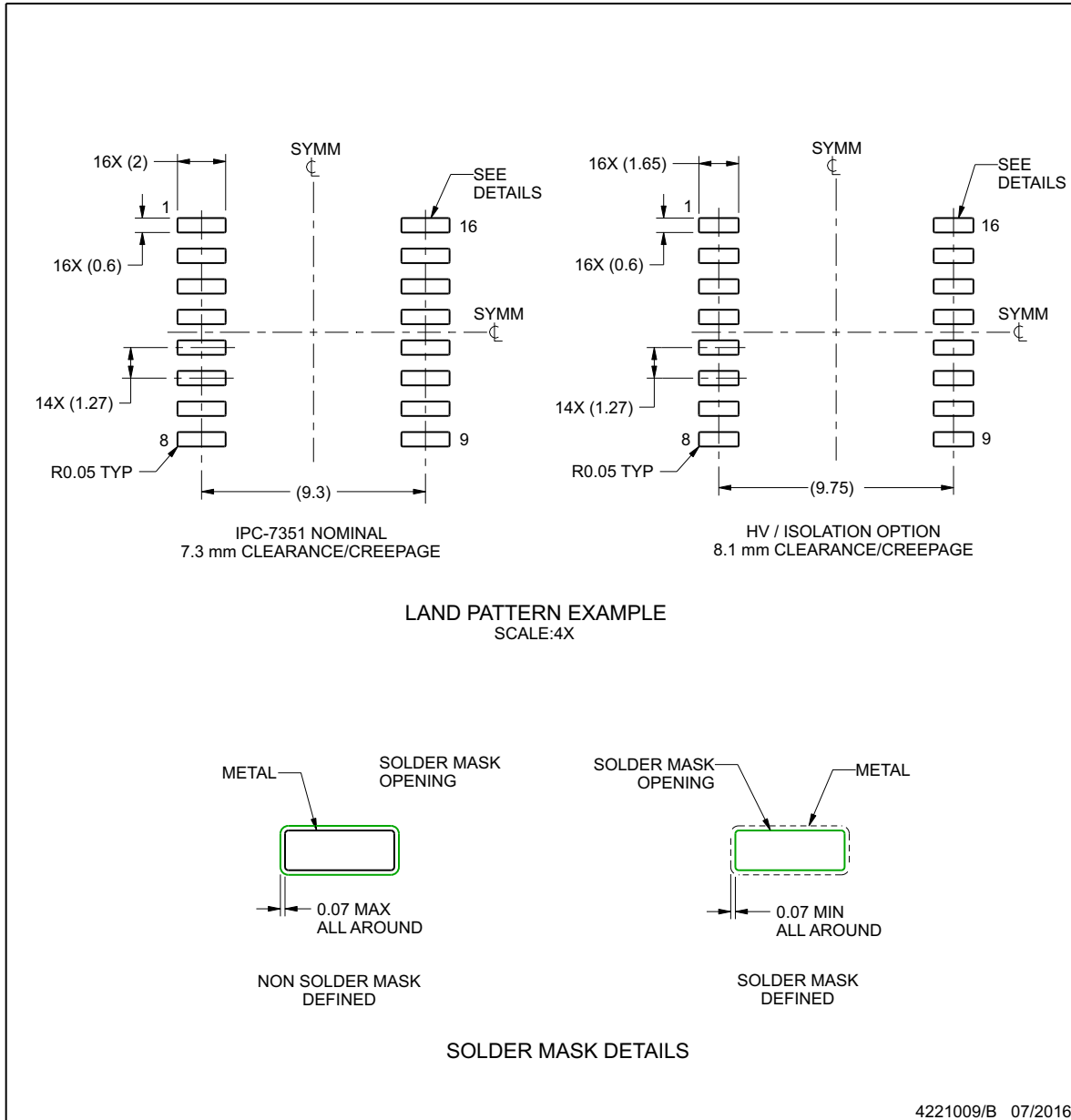

NOTES: (continued)

- 6. Publication IPC-7351 may have alternate designs.
- 7. Solder mask tolerances between and around signal pads can vary based on board fabrication site.

EXAMPLE STENCIL DESIGN

DW0016B

SOIC - 2.65 mm max height

SOIC

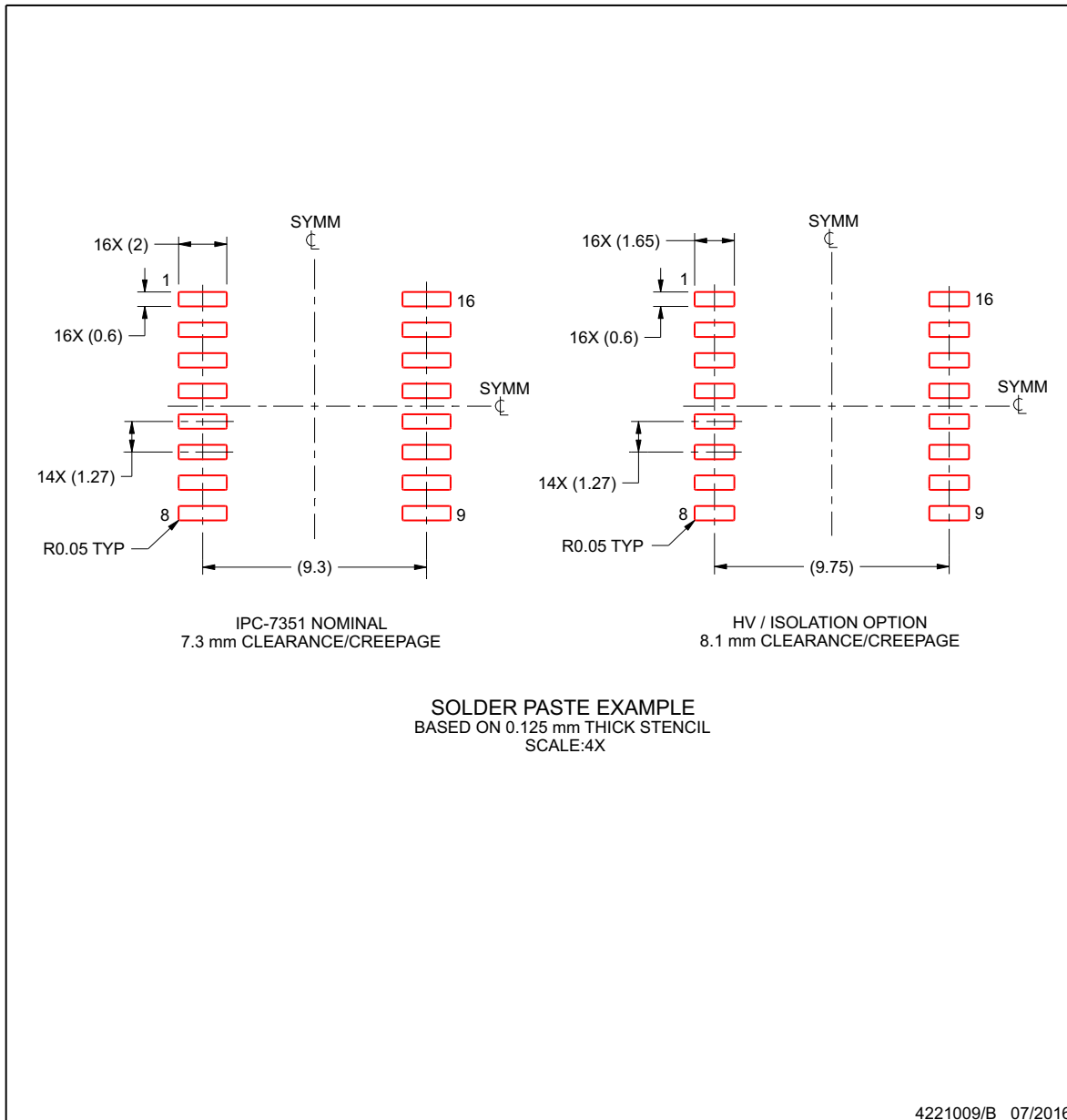

NOTES: (continued)

- 8. Laser cutting apertures with trapezoidal walls and rounded corners may offer better paste release. IPC-7525 may have alternate design recommendations.
- 9. Board assembly site may have different recommendations for stencil design.



DWW0016A

PACKAGE OUTLINE

SOIC - 2.65 mm max height

PLASTIC SMALL OUTLINE

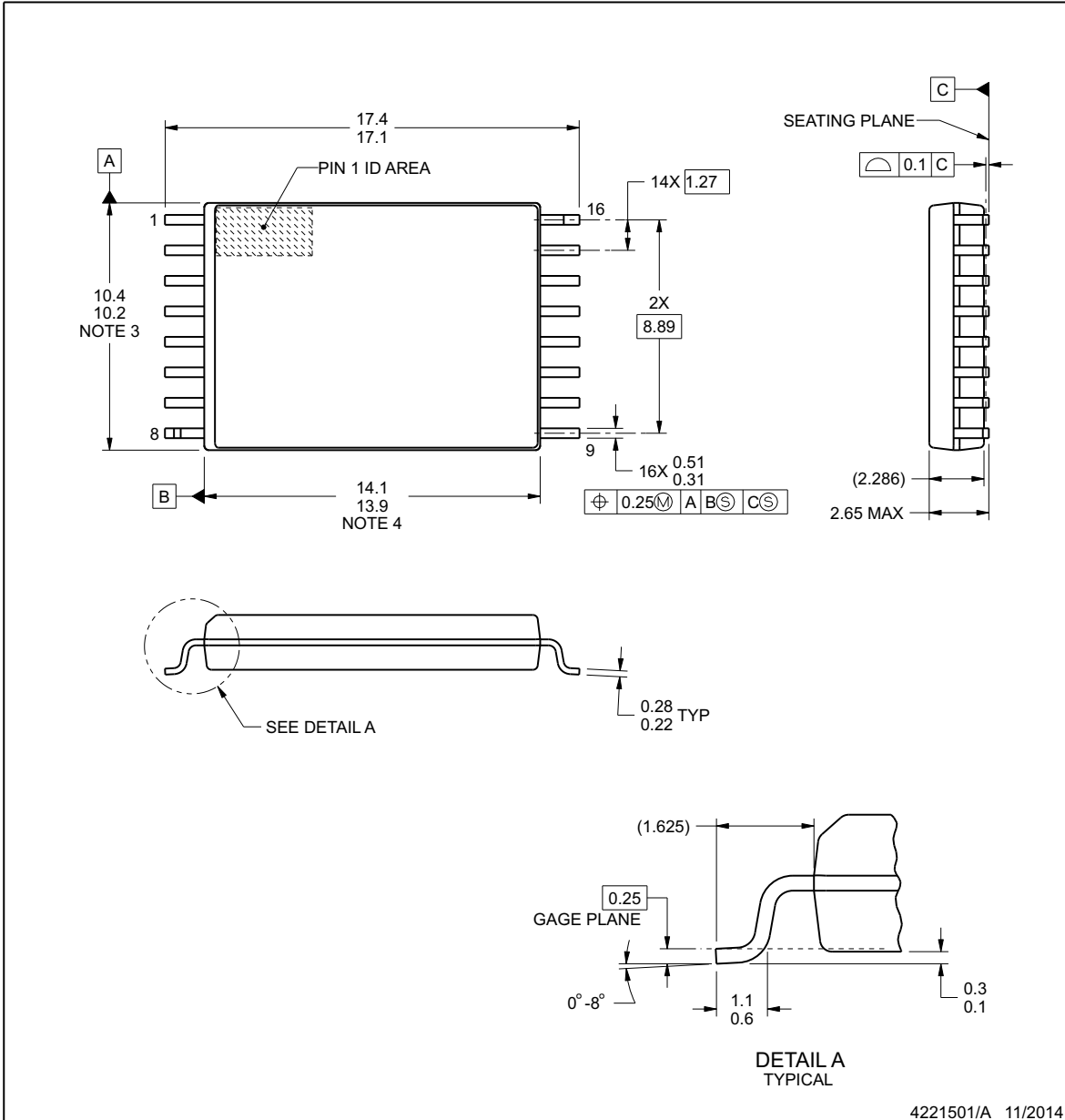

4221501/A 11/2014

NOTES:

1. All linear dimensions are in millimeters. Any dimensions in parenthesis are for reference only. Dimensioning and tolerancing per ASME Y14.5M.
2. This drawing is subject to change without notice.
3. This dimension does not include mold flash, protrusions, or gate burrs. Mold flash, protrusions, or gate burrs shall not exceed 0.15 mm per side.
4. This dimension does not include interlead flash.

EXAMPLE BOARD LAYOUT

DWW0016A

SOIC - 2.65 mm max height

PLASTIC SMALL OUTLINE

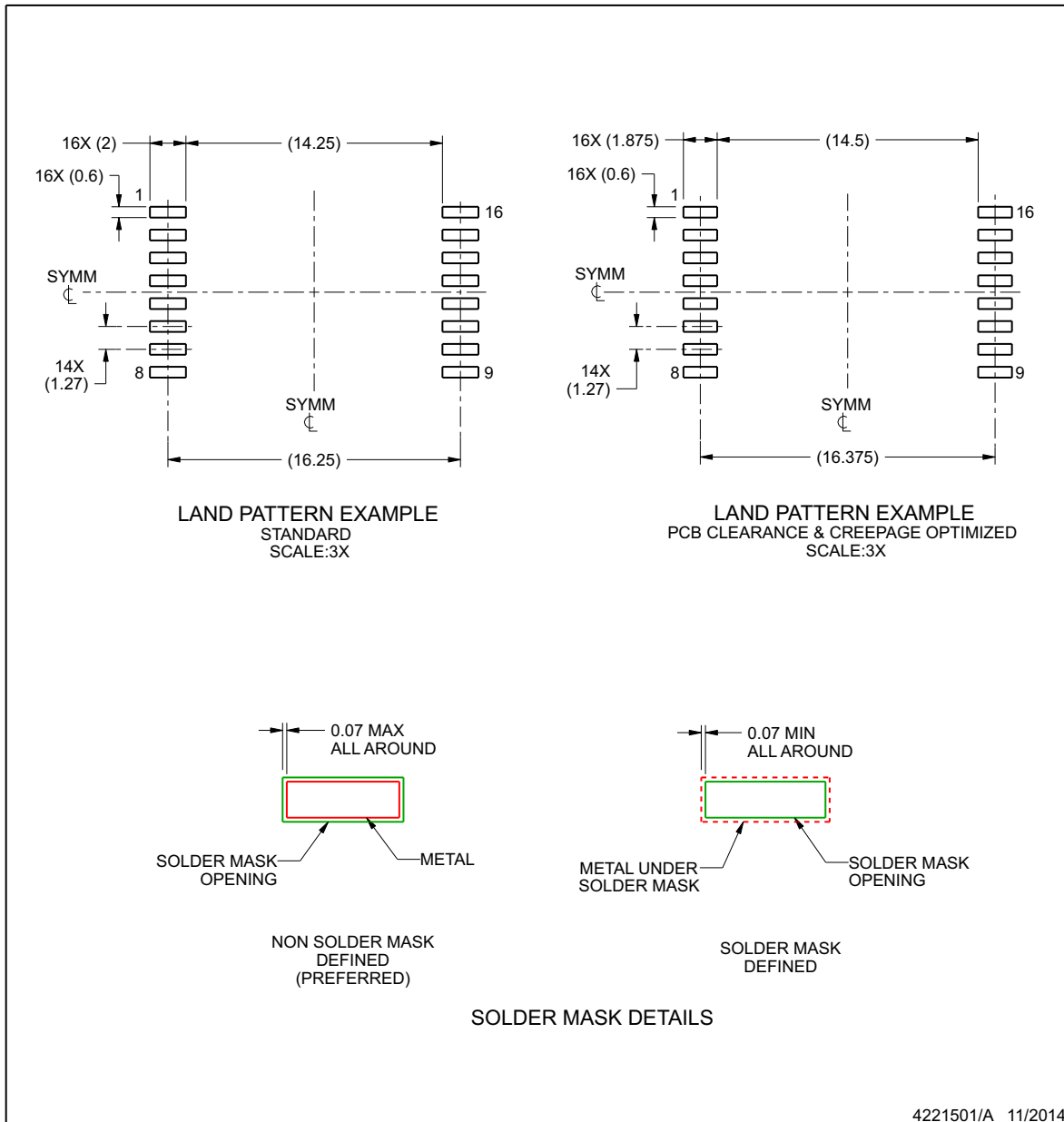

NOTES: (continued)

- 5. Publication IPC-7351 may have alternate designs.
- 6. Solder mask tolerances between and around signal pads can vary based on board fabrication site.

EXAMPLE STENCIL DESIGN

DWW0016A

SOIC - 2.65 mm max height

PLASTIC SMALL OUTLINE

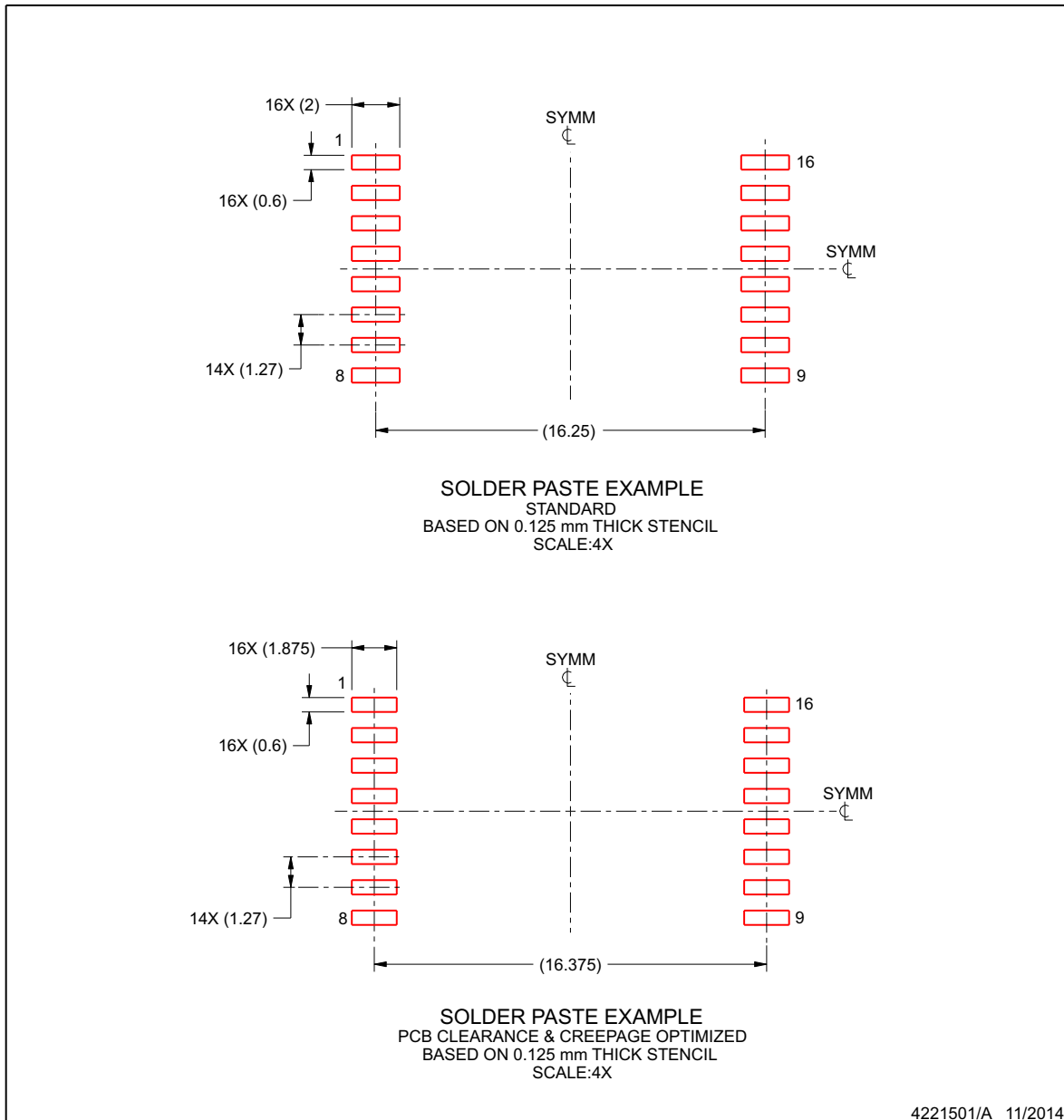

NOTES: (continued)

7. Laser cutting apertures with trapezoidal walls and rounded corners may offer better paste release. IPC-7525 may have alternate design recommendations.
8. Board assembly site may have different recommendations for stencil design.

PACKAGING INFORMATION

Orderable Device	Status (1)	Package Type	Package Drawing	Pins	Package Qty	Eco Plan (2)	Lead finish/ Ball material (6)	MSL Peak Temp (3)	Op Temp (°C)	Device Marking (4/5)	Samples
ISO7841DW	ACTIVE	SOIC	DW	16	40	RoHS & Green	NIPDAU	Level-2-260C-1 YEAR	-55 to 125	ISO7841	Samples
ISO7841DWR	ACTIVE	SOIC	DW	16	2000	RoHS & Green	NIPDAU	Level-2-260C-1 YEAR	-55 to 125	ISO7841	Samples
ISO7841DWW	ACTIVE	SOIC	DWW	16	45	RoHS & Green	NIPDAU	Level-2-260C-1 YEAR	-55 to 125	ISO7841	Samples
ISO7841DWWR	ACTIVE	SOIC	DWW	16	1000	RoHS & Green	NIPDAU	Level-2-260C-1 YEAR	-55 to 125	ISO7841	Samples
ISO7841FDW	ACTIVE	SOIC	DW	16	40	RoHS & Green	NIPDAU	Level-2-260C-1 YEAR	-55 to 125	ISO7841F	Samples
ISO7841FDWR	ACTIVE	SOIC	DW	16	2000	RoHS & Green	NIPDAU	Level-2-260C-1 YEAR	-55 to 125	ISO7841F	Samples
ISO7841FDWW	ACTIVE	SOIC	DWW	16	45	RoHS & Green	NIPDAU	Level-2-260C-1 YEAR	-55 to 125	ISO7841F	Samples
ISO7841FDWWR	ACTIVE	SOIC	DWW	16	1000	RoHS & Green	NIPDAU	Level-2-260C-1 YEAR	-55 to 125	ISO7841F	Samples

(1) The marketing status values are defined as follows:

ACTIVE: Product device recommended for new designs.

LIFEBUY: TI has announced that the device will be discontinued, and a lifetime-buy period is in effect.

NRND: Not recommended for new designs. Device is in production to support existing customers, but TI does not recommend using this part in a new design.

PREVIEW: Device has been announced but is not in production. Samples may or may not be available.

OBSELETE: TI has discontinued the production of the device.

(2) **RoHS:** TI defines "RoHS" to mean semiconductor products that are compliant with the current EU RoHS requirements for all 10 RoHS substances, including the requirement that RoHS substance do not exceed 0.1% by weight in homogeneous materials. Where designed to be soldered at high temperatures, "RoHS" products are suitable for use in specified lead-free processes. TI may reference these types of products as "Pb-Free".

RoHS Exempt: TI defines "RoHS Exempt" to mean products that contain lead but are compliant with EU RoHS pursuant to a specific EU RoHS exemption.

Green: TI defines "Green" to mean the content of Chlorine (Cl) and Bromine (Br) based flame retardants meet JS709B low halogen requirements of <=1000ppm threshold. Antimony trioxide based flame retardants must also meet the <=1000ppm threshold requirement.

(3) MSL, Peak Temp. - The Moisture Sensitivity Level rating according to the JEDEC industry standard classifications, and peak solder temperature.

(4) There may be additional marking, which relates to the logo, the lot trace code information, or the environmental category on the device.

(5) Multiple Device Markings will be inside parentheses. Only one Device Marking contained in parentheses and separated by a "~" will appear on a device. If a line is indented then it is a continuation of the previous line and the two combined represent the entire Device Marking for that device.

⁽⁶⁾ Lead finish/Ball material - Orderable Devices may have multiple material finish options. Finish options are separated by a vertical ruled line. Lead finish/Ball material values may wrap to two lines if the finish value exceeds the maximum column width.

Important Information and Disclaimer: The information provided on this page represents TI's knowledge and belief as of the date that it is provided. TI bases its knowledge and belief on information provided by third parties, and makes no representation or warranty as to the accuracy of such information. Efforts are underway to better integrate information from third parties. TI has taken and continues to take reasonable steps to provide representative and accurate information but may not have conducted destructive testing or chemical analysis on incoming materials and chemicals. TI and TI suppliers consider certain information to be proprietary, and thus CAS numbers and other limited information may not be available for release.

In no event shall TI's liability arising out of such information exceed the total purchase price of the TI part(s) at issue in this document sold by TI to Customer on an annual basis.

TAPE AND REEL INFORMATION

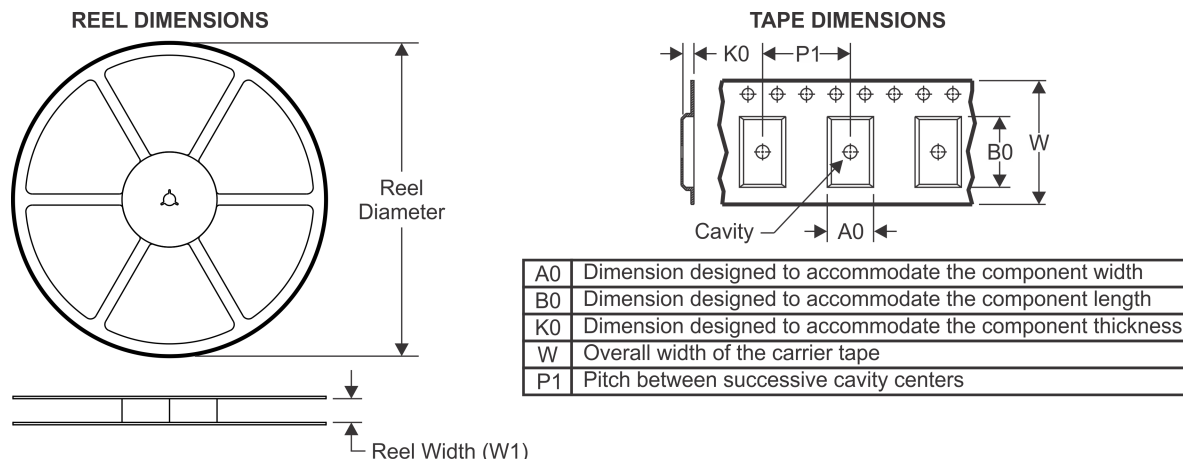

QUADRANT ASSIGNMENTS FOR PIN 1 ORIENTATION IN TAPE



*All dimensions are nominal

Device	Package Type	Package Drawing	Pins	SPQ	Reel Diameter (mm)	Reel Width W1 (mm)	A0 (mm)	B0 (mm)	K0 (mm)	P1 (mm)	W (mm)	Pin1 Quadrant
ISO7841DWR	SOIC	DW	16	2000	330.0	16.4	10.75	10.7	2.7	12.0	16.0	Q1
ISO7841DWWR	SOIC	DWW	16	1000	330.0	24.4	18.0	10.0	3.0	20.0	24.0	Q1
ISO7841FDWR	SOIC	DW	16	2000	330.0	16.4	10.75	10.7	2.7	12.0	16.0	Q1
ISO7841FDWWR	SOIC	DWW	16	1000	330.0	24.4	18.0	10.0	3.0	20.0	24.0	Q1

TAPE AND REEL BOX DIMENSIONS

*All dimensions are nominal

Device	Package Type	Package Drawing	Pins	SPQ	Length (mm)	Width (mm)	Height (mm)
ISO7841DWR	SOIC	DW	16	2000	350.0	350.0	43.0
ISO7841DWWR	SOIC	DWW	16	1000	350.0	350.0	43.0
ISO7841FDWR	SOIC	DW	16	2000	350.0	350.0	43.0
ISO7841FDWWR	SOIC	DWW	16	1000	350.0	350.0	43.0

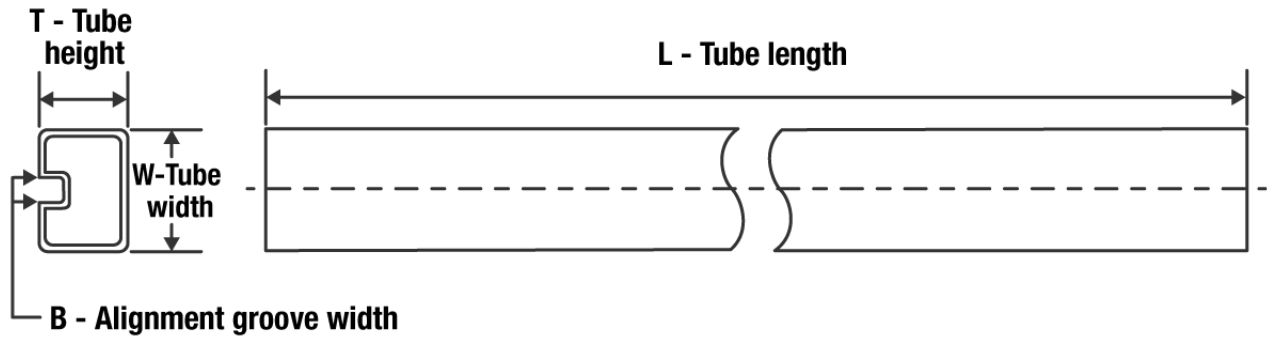
TUBE

*All dimensions are nominal

Device	Package Name	Package Type	Pins	SPQ	L (mm)	W (mm)	T (μm)	B (mm)
ISO7841DW	DW	SOIC	16	40	506.98	12.7	4826	6.6
ISO7841DWW	DWW	SOIC	16	45	507	20	5000	9
ISO7841FDW	DW	SOIC	16	40	506.98	12.7	4826	6.6
ISO7841FDWW	DWW	SOIC	16	45	507	20	5000	9

重要声明和免责声明

TI“按原样”提供技术和可靠性数据（包括数据表）、设计资源（包括参考设计）、应用或其他设计建议、网络工具、安全信息和其他资源，不保证没有瑕疵且不做任何明示或暗示的担保，包括但不限于对适销性、某特定用途方面的适用性或不侵犯任何第三方知识产权的暗示担保。

这些资源可供使用 TI 产品进行设计的熟练开发人员使用。您将自行承担以下全部责任：(1) 针对您的应用选择合适的 TI 产品，(2) 设计、验证并测试您的应用，(3) 确保您的应用满足相应标准以及任何其他功能安全、信息安全、监管或其他要求。

这些资源如有变更，恕不另行通知。TI 授权您仅可将这些资源用于研发本资源所述的 TI 产品的应用。严禁对这些资源进行其他复制或展示。您无权使用任何其他 TI 知识产权或任何第三方知识产权。您应全额赔偿因在这些资源的使用中对 TI 及其代表造成的任何索赔、损害、成本、损失和债务，TI 对此概不负责。

TI 提供的产品受 [TI 的销售条款](#) 或 [ti.com](#) 上其他适用条款/TI 产品随附的其他适用条款的约束。TI 提供这些资源并不会扩展或以其他方式更改 TI 针对 TI 产品发布的适用的担保或担保免责声明。

TI 反对并拒绝您可能提出的任何其他或不同的条款。

邮寄地址：Texas Instruments, Post Office Box 655303, Dallas, Texas 75265

Copyright © 2022，德州仪器 (TI) 公司