

## ISO732x-Q1 耐用 EMC 低功耗双通道数字隔离器

### 1 特性

- 符合汽车应用要求
- 具有符合 AEC-Q100 的下列结果：
  - 器件温度 1 级：-40°C 至 +125°C 的环境运行温度范围
  - 器件人体模型 (HBM) 分类等级 3A
  - 器件充电器件模型 (CDM) 分类等级 C6
- 信号传输速率：25Mbps
- 输入时使用集成噪声滤波器
- 默认输出高电平和低电平选项
- 低功耗：每通道的  $I_{CC}$  典型值（1Mbps 时）：
  - ISO7320-Q1：1.2mA（5V 电源），0.9mA（3.3V 电源）
  - ISO7321-Q1：1.7mA（5V 电源），1.2mA（3.3V 电源）
- 低传播延迟：典型值 33ns（5V 电源）
- 3.3V 和 5V 电平转换
- 65kV/ $\mu$ s 瞬态抗扰度，典型值（5V 电源）
- 优异的电磁兼容性 (EMC)
  - 系统级静电放电 (ESD)、瞬态放电 (EFT) 以及抗浪涌保护
  - 低辐射
- 隔离栅寿命：> 25 年
- 由 3.3V 和 5V 电源供电
- 窄体小尺寸集成电路 (SOIC)-8 封装
- 安全及管理批准：
  - 符合 DIN V VDE V 0884-10 和 DIN EN 61010-1 标准的 4242  $V_{PK}$  隔离中的 4242 VPK 部分
  - 符合 UL 1577 标准且长达 1 分钟的 3000  $V_{RMS}$  隔离
  - CSA 组件接受通知 5A，IEC 60950-1、IEC 60601-1 和 IEC 61010-1 标准中 CSA 组件接受列表项的“（审批正在审理中）”
  - 已通过符合 GB4943.1-2011 的 CQC 认证

### 2 应用

- 在下列使用中的光电耦合器替代产品：
  - 工业用 FieldBus
    - ProfiBus
    - ModBus
    - DeviceNet™ 数据总线
  - 伺服控制接口
  - 电机控制

- 电源
- 电池组

### 3 说明

ISO732x-Q1 系列器件可提供符合 UL 1577 标准的长达 1 分钟且高达 3000  $V_{RMS}$  的电流隔离，以及符合 VDE V 0884-10 标准的 4242  $V_{PK}$  隔离。这些器件具有两个隔离通道，其逻辑输入和输出缓冲器由二氧化硅 ( $SiO_2$ ) 绝缘栅分离开来。

ISO7320-Q1 的两个通道方向相同，而 ISO7321-Q1 的两个通道方向相反。如果出现输入功率或信号损失，默认输出低电平（器件的订购部件号带有后缀 F）或高电平（器件的订购部件号不带后缀 F）。更多信息，请参见 *Device Functional Modes*。与隔离式电源一起使用时，这些器件有助于防止数据总线或者其他电路上的噪声电流进入本地接地或对敏感电路造成干扰或损坏。ISO734x-Q1 系列器件已针对恶劣工业环境集成了噪声滤波器。在此类环境下，器件的输入引脚上可能会出现短噪声脉冲。ISO732x-Q1 系列器件具有晶体管-晶体管逻辑电路 (TTL) 输入阈值，工作电压范围为 3V 到 5.5V。

凭借创新的芯片设计和布线技术，ISO732x-Q1 系列器件的电磁兼容性得到了显著增强，可确保提供系统级 ESD、EFT 和浪涌保护并符合辐射标准。

器件信息<sup>(1)</sup>

器件型号	封装	封装尺寸（标称值）
ISO7320-Q1	SOIC (8)	4.90mm x 3.91mm
ISO7321-Q1		

(1) 如需了解所有可用封装，请见数据表末尾的可订购产品附录。

部分增加了脚注。

简化电路原理图

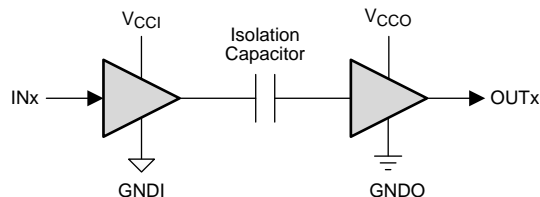

$V_{CCI}$  和  $GNDI$  分别是输入通道的电源和接地连接。

$V_{CCO}$  和  $GND0$  分别是输出通道的电源和接地连接。



## 目录

<b>1</b>	特性 .....	1	8.1	Overview .....	11
<b>2</b>	应用 .....	1	8.2	Functional Block Diagram .....	11
<b>3</b>	说明 .....	1	8.3	Feature Description .....	12
<b>4</b>	修订历史记录 .....	2	8.4	Device Functional Modes .....	15
<b>5</b>	<b>Pin Configuration and Functions</b> .....	3	<b>9</b>	<b>Application and Implementation</b> .....	16
<b>6</b>	<b>Specifications</b> .....	4	9.1	Application Information .....	16
6.1	Absolute Maximum Ratings .....	4	9.2	Typical Application .....	16
6.2	ESD Ratings .....	4	<b>10</b>	<b>Power Supply Recommendations</b> .....	18
6.3	Recommended Operating Conditions .....	4	<b>11</b>	<b>Layout</b> .....	18
6.4	Thermal Information .....	4	11.1	Layout Guidelines .....	18
6.5	Electrical Characteristics—5-V Supply .....	5	11.2	Layout Example .....	19
6.6	Supply Current Characteristics—5-V Supply .....	5	<b>12</b>	<b>器件和文档支持</b> .....	20
6.7	Electrical Characteristics—3.3 V .....	6	12.1	文档支持 .....	20
6.8	Supply Current Characteristics—3.3-V Supply .....	6	12.2	相关链接 .....	20
6.9	Power Dissipation Characteristics .....	6	12.3	社区资源 .....	20
6.10	Switching Characteristics—5-V Supply .....	7	12.4	商标 .....	20
6.11	Switching Characteristics—3.3-V Supply .....	7	12.5	静电放电警告 .....	20
6.12	Typical Characteristics .....	8	12.6	Glossary .....	20
<b>7</b>	<b>Parameter Measurement Information</b> .....	10	<b>13</b>	<b>机械、封装和可订购信息</b> .....	21
<b>8</b>	<b>Detailed Description</b> .....	11			

## 4 修订历史记录

注：之前版本的页码可能与当前版本有所不同。

日期	修订版本	注释
2015 年 11 月	*	最初发布。

## 5 Pin Configuration and Functions

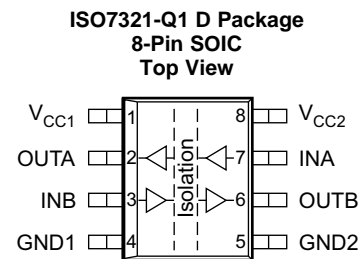
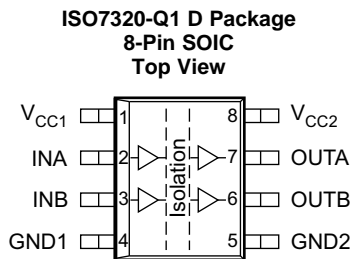

### Pin Functions

NAME	PIN		I/O	DESCRIPTION
	NO.			
	ISO7320-Q1	ISO7321-Q1		
INA	2	7	I	Input, channel A
INB	3	3	I	Input, channel B
GND1	4	4	—	Ground connection for $V_{CC1}$
GND2	5	5	—	Ground connection for $V_{CC2}$
OUTA	7	2	O	Output, channel A
OUTB	6	6	O	Output, channel B
$V_{CC1}$	1	1	—	Power supply, $V_{CC1}$
$V_{CC2}$	8	8	—	Power supply, $V_{CC2}$

## 6 Specifications

### 6.1 Absolute Maximum Ratings

over operating free-air temperature range (unless otherwise noted)<sup>(1)</sup>

			MIN	MAX	UNIT
V <sub>CC</sub>	Supply voltage <sup>(2)</sup>	V <sub>CC1</sub> , V <sub>CC2</sub>	-0.5	6	V
	Voltage <sup>(2)</sup>	INx, OUTx	-0.5	V <sub>CC</sub> + 0.5 <sup>(3)</sup>	V
I <sub>O</sub>	Output current			±15	mA
T <sub>J</sub>	Junction temperature			150	°C
T <sub>stg</sub>	Storage temperature		-65	150	°C

- (1) Stresses beyond those listed under *absolute maximum ratings* may cause permanent damage to the device. These are stress ratings only and functional operation of the device at these or any other conditions beyond those indicated under *recommended operating conditions* is not implied. Exposure to absolute-maximum-rated conditions for extended periods may affect device reliability.
- (2) All voltage values are with respect to network ground terminal and are peak voltage values.
- (3) Maximum voltage must not exceed 6 V.

### 6.2 ESD Ratings

			VALUE	UNIT
V <sub>(ESD)</sub>	Electrostatic discharge	Human-body model (HBM), per AEC Q100-002 <sup>(1)</sup>	±4000	V
		Charged-device model (CDM), per AEC Q100-011	±1500	

- (1) AEC Q100-002 indicates that HBM stressing shall be in accordance with the ANSI/ESDA/JEDEC JS-001 specification.

### 6.3 Recommended Operating Conditions

		MIN	NOM	MAX	UNIT
V <sub>CC1</sub> , V <sub>CC2</sub>	Supply voltage,	3		5.5	V
I <sub>OH</sub>	High-level output current	-4			mA
I <sub>OL</sub>	Low-level output current			4	mA
V <sub>IH</sub>	High-level input voltage	2		5.5	V
V <sub>IL</sub>	Low-level input voltage	0		0.8	V
t <sub>ui</sub>	Input pulse duration	40			ns
1 / t <sub>ui</sub>	Signaling rate	0		25	Mbps
T <sub>J</sub> <sup>(1)</sup>	Junction temperature			136	°C
T <sub>A</sub>	Ambient temperature	-40	25	125	°C

- (1) To maintain the recommended operating conditions for T<sub>J</sub>, see the [Thermal Information](#) table.

### 6.4 Thermal Information

THERMAL METRIC <sup>(1)</sup>	ISO732x-Q1		UNIT
	D (SOIC)		
	8 PINS		
R <sub>θJA</sub>	Junction-to-ambient thermal resistance	121	°C/W
R <sub>θJctop</sub>	Junction-to-case (top) thermal resistance	67.9	°C/W
R <sub>θJB</sub>	Junction-to-board thermal resistance	61.6	°C/W
ψ <sub>JT</sub>	Junction-to-top characterization parameter	21.5	°C/W
ψ <sub>JB</sub>	Junction-to-board characterization parameter	61.1	°C/W
R <sub>θJcbot</sub>	Junction-to-case (bottom) thermal resistance	N/A	°C/W

- (1) For more information about traditional and new thermal metrics, see the *Semiconductor and IC Package Thermal Metrics application report*, [SPRA953](#).

## 6.5 Electrical Characteristics—5-V Supply

 $V_{CC1}$  and  $V_{CC2}$  at 5 V  $\pm$  10% (over recommended operating conditions unless otherwise noted)

PARAMETER		TEST CONDITIONS	MIN	TYP	MAX	UNIT
$V_{OH}$	High-level output voltage	$I_{OH} = -4$ mA; see Figure 11	$V_{CCO}^{(1)} - 0.5$	4.7		V
		$I_{OH} = -20$ $\mu$ A; see Figure 11	$V_{CCO}^{(1)} - 0.1$	5		
$V_{OL}$	Low-level output voltage	$I_{OL} = 4$ mA; see Figure 11		0.2	0.4	V
		$I_{OL} = 20$ $\mu$ A; see Figure 11		0	0.1	
$V_{I(HYS)}$	Input threshold voltage hysteresis			460		mV
$I_{IH}$	High-level input current	$I_N = V_{CC}$			10	$\mu$ A
$I_{IL}$	Low-level input current	$I_N = 0$ V	-10			$\mu$ A
CMTI	Common-mode transient immunity	$V_I = V_{CC}$ or 0 V; see Figure 13.	25	65		kV/ $\mu$ s

(1)  $V_{CCO}$  is supply voltage,  $V_{CC1}$  or  $V_{CC2}$ , for the output channel being measured.

## 6.6 Supply Current Characteristics—5-V Supply

All inputs switching with square wave clock signal for dynamic  $I_{CC}$  measurement.  $V_{CC1}$  and  $V_{CC2}$  at 5 V  $\pm$  10% (over recommended operating conditions unless otherwise noted)

PARAMETER	TEST CONDITIONS		SUPPLY CURRENT	MIN	TYP	MAX	UNIT
<b>ISO7320-Q1</b>							
Supply current for $V_{CC1}$ and $V_{CC2}$	DC to 1 Mbps	DC Input: $V_I = V_{CC}$ or 0 V, AC Input: $C_L = 15$ pF	$I_{CC1}$		0.4	0.9	mA
			$I_{CC2}$		2	3.2	
	10 Mbps	$C_L = 15$ pF	$I_{CC1}$		0.8	1.4	
			$I_{CC2}$		3.2	4.4	
	25 Mbps	$C_L = 15$ pF	$I_{CC1}$		1.4	2.3	
			$I_{CC2}$		4.9	6.8	
<b>ISO7321-Q1</b>							
Supply current for $V_{CC1}$ and $V_{CC2}$	DC to 1 Mbps	DC Input: $V_I = V_{CC}$ or 0 V, AC Input: $C_L = 15$ pF	$I_{CC1}$ , $I_{CC2}$		1.7	2.8	mA
	10 Mbps	$C_L = 15$ pF	$I_{CC1}$ , $I_{CC2}$		2.5	3.7	
	25 Mbps	$C_L = 15$ pF	$I_{CC1}$ , $I_{CC2}$		3.7	5.4	

### 6.7 Electrical Characteristics—3.3 V

$V_{CC1}$  and  $V_{CC2}$  at 3.3 V  $\pm$  10% (over recommended operating conditions unless otherwise noted)

PARAMETER		TEST CONDITIONS	MIN	TYP	MAX	UNIT
$V_{OH}$	High-level output voltage	$I_{OH} = -4$ mA; see Figure 11	$V_{CCO}^{(1)} - 0.5$	3		V
		$I_{OH} = -20$ $\mu$ A; see Figure 11	$V_{CCO}^{(1)} - 0.1$	3.3		
$V_{OL}$	Low-level output voltage	$I_{OL} = 4$ mA; see Figure 11		0.2	0.4	V
		$I_{OL} = 20$ $\mu$ A; see Figure 11		0	0.1	
$V_{I(HYS)}$	Input threshold voltage hysteresis			450		mV
$I_{IH}$	High-level input current	$I_N = V_{CC}$			10	$\mu$ A
$I_{IL}$	Low-level input current	$I_N = 0$ V	-10			$\mu$ A
CMTI	Common-mode transient immunity	$V_I = V_{CC}$ or 0 V; see Figure 13	25	50		kV/ $\mu$ s

(1)  $V_{CCO}$  is supply voltage,  $V_{CC1}$  or  $V_{CC2}$ , for the output channel being measured.

### 6.8 Supply Current Characteristics—3.3-V Supply

All inputs switching with square wave clock signal for dynamic  $I_{CC}$  measurement.  $V_{CC1}$  and  $V_{CC2}$  at 3.3 V  $\pm$  10% (over recommended operating conditions unless otherwise noted)

PARAMETER		TEST CONDITIONS	SUPPLY CURRENT	MIN	TYP	MAX	UNIT
<b>ISO7320-Q1</b>							
Supply current for $V_{CC1}$ and $V_{CC2}$	DC to 1 Mbps	DC Input: $V_I = V_{CC}$ or 0 V, AC Input: $C_L = 15$ pF	$I_{CC1}$		0.2	0.5	mA
			$I_{CC2}$		1.5	2.5	
	10 Mbps	$C_L = 15$ pF	$I_{CC1}$		0.5	0.8	
			$I_{CC2}$		2.2	3.2	
	25 Mbps	$C_L = 15$ pF	$I_{CC1}$		0.9	1.4	
			$I_{CC2}$		3.3	4.7	
<b>ISO7321-Q1</b>							
Supply current for $V_{CC1}$ and $V_{CC2}$	DC to 1 Mbps	DC Input: $V_I = V_{CC}$ or 0 V, AC Input: $C_L = 15$ pF	$I_{CC1}, I_{CC2}$		1.2	2	mA
	10 Mbps	$C_L = 15$ pF	$I_{CC1}, I_{CC2}$		1.7	2.5	
	25 Mbps	$C_L = 15$ pF	$I_{CC1}, I_{CC2}$		2.5	3.6	

### 6.9 Power Dissipation Characteristics

$V_{CC1} = V_{CC2} = 5.5$  V,  $T_J = 150^\circ$ C,  $C_L = 15$  pF, input a 12.5 MHz 50% duty-cycle square wave (unless otherwise noted)

PARAMETER		TEST CONDITIONS	MIN	TYP	MAX	UNIT
$P_D$	Maximum power dissipation by ISO7320-Q1				56	mW
$P_{D1}$	Maximum power dissipation by side-1 of ISO7320-Q1				15	mW
$P_{D2}$	Maximum power dissipation by side-2 of ISO7320-Q1				41	mW
$P_D$	Maximum power dissipation by ISO7321-Q1				67	mW
$P_{D1}$	Maximum power dissipation by side-1 of ISO7321-Q1				33.5	mW
$P_{D2}$	Maximum power dissipation by side-2 of ISO7321-Q1				33.5	mW

## 6.10 Switching Characteristics—5-V Supply

 $V_{CC1}$  and  $V_{CC2}$  at 5 V  $\pm$  10% (over recommended operating conditions unless otherwise noted)

PARAMETER		TEST CONDITIONS	MIN	TYP	MAX	UNIT
$t_{PLH}$ , $t_{PHL}$	Propagation delay time	See Figure 11	20	33	57	ns
PWD <sup>(1)</sup>	Pulse width distortion $ t_{PHL} - t_{PLH} $	See Figure 11			4	ns
$t_{sk(o)}$ <sup>(2)</sup>	Channel-to-channel output skew time	ISO7320-Q1			2	ns
		ISO7321-Q1			17	
$t_{sk(pp)}$ <sup>(3)</sup>	Part-to-part skew time				23	ns
$t_r$	Output signal rise time	See Figure 11		2.4		ns
$t_f$	Output signal fall time	See Figure 11		2.1		ns
$t_{fs}$	Fail-safe output delay time from input power loss	See Figure 12		7.5		$\mu$ s

- (1) Also known as pulse skew.
- (2)  $t_{sk(o)}$  is the skew between outputs of a single device with all driving inputs connected together and the outputs switching in the same direction while driving identical loads.
- (3)  $t_{sk(pp)}$  is the magnitude of the difference in propagation delay times between any terminals of different devices switching in the same direction while operating at identical supply voltages, temperature, input signals and loads.

## 6.11 Switching Characteristics—3.3-V Supply

 $V_{CC1}$  and  $V_{CC2}$  at 3.3 V  $\pm$  10% (over recommended operating conditions unless otherwise noted)

PARAMETER		TEST CONDITIONS	MIN	TYP	MAX	UNIT
$t_{PLH}$ , $t_{PHL}$	Propagation delay time	See Figure 11	22	37	66	ns
PWD <sup>(1)</sup>	Pulse width distortion $ t_{PHL} - t_{PLH} $	See Figure 11			3	ns
$t_{sk(o)}$ <sup>(2)</sup>	Channel-to-channel output skew time	ISO7320-Q1			3	ns
		ISO7321-Q1			16	
$t_{sk(pp)}$ <sup>(3)</sup>	Part-to-part skew time				28	ns
$t_r$	Output signal rise time	See Figure 11		3.1		ns
$t_f$	Output signal fall time	See Figure 11		2.6		ns
$t_{fs}$	Fail-safe output delay time from input power loss	See Figure 12		7.4		$\mu$ s

- (1) Also known as pulse skew.
- (2)  $t_{sk(o)}$  is the skew between outputs of a single device with all driving inputs connected together and the outputs switching in the same direction while driving identical loads.
- (3)  $t_{sk(pp)}$  is the magnitude of the difference in propagation delay times between any terminals of different devices switching in the same direction while operating at identical supply voltages, temperature, input signals and loads.

## 6.12 Typical Characteristics

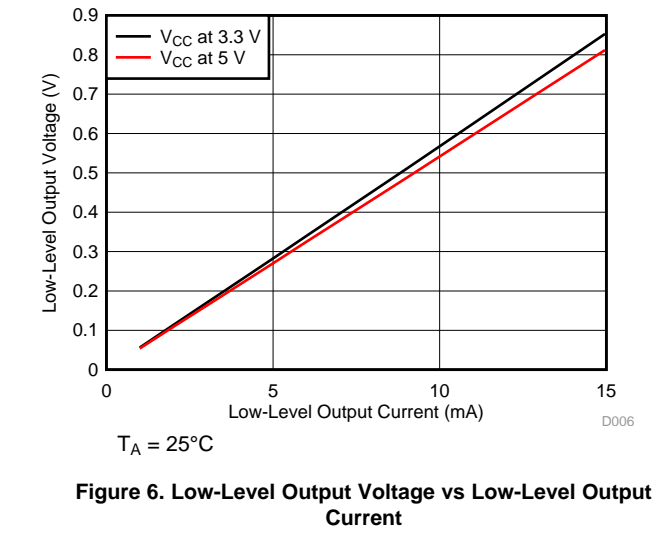
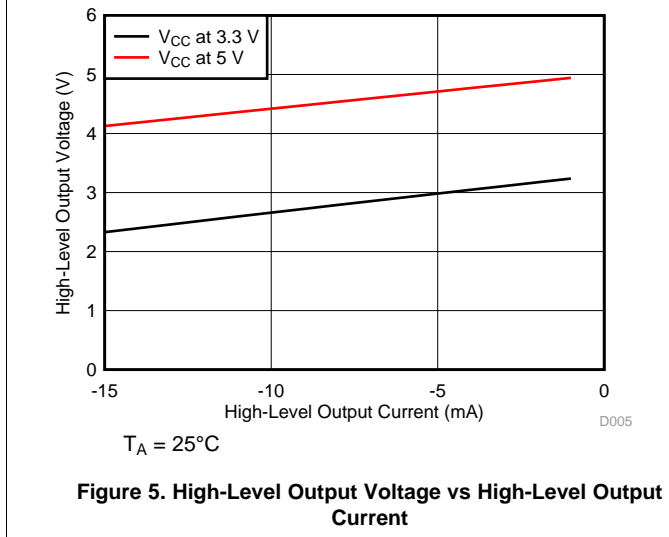
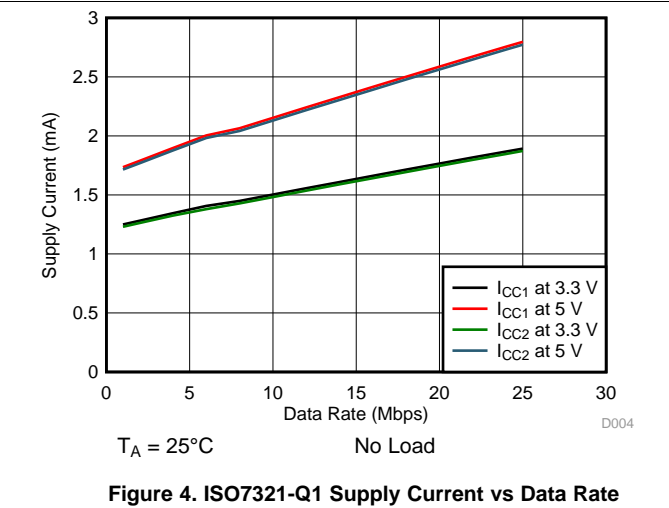
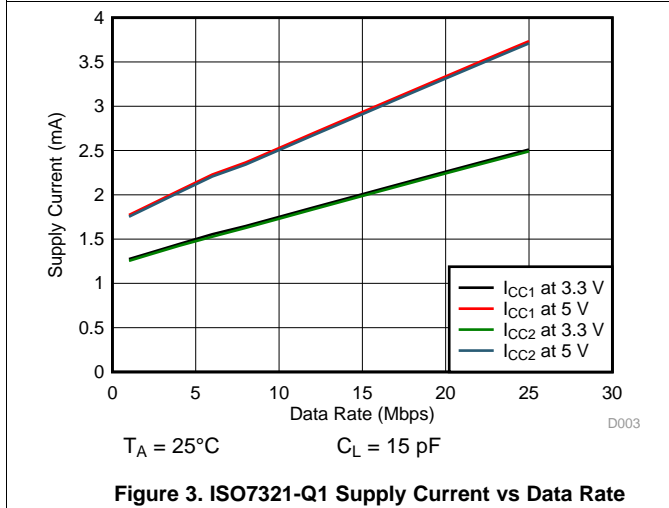
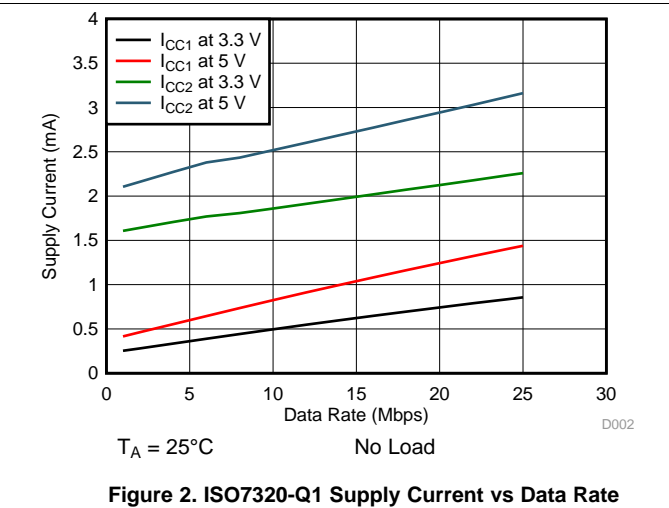
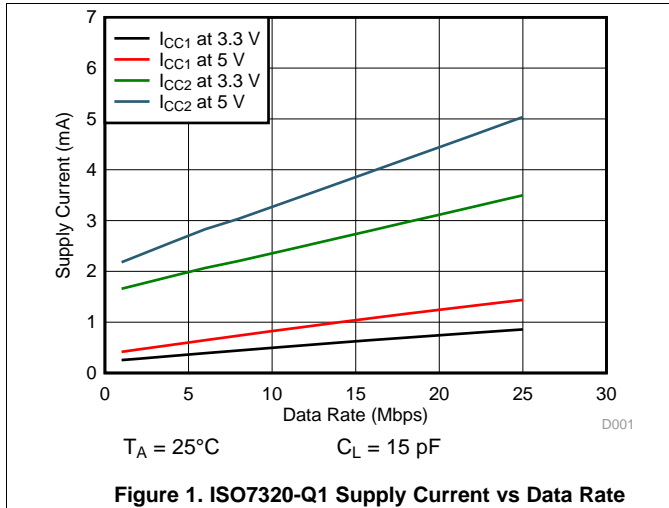

Typical Characteristics (continued)

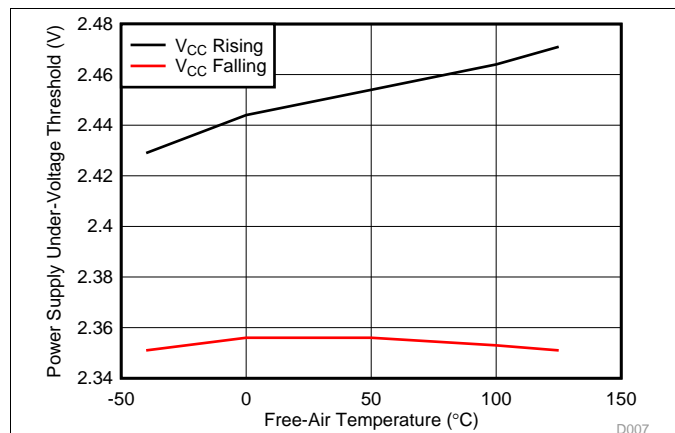

Figure 7. Power Supply Under Voltage Threshold vs Free-Air Temperature

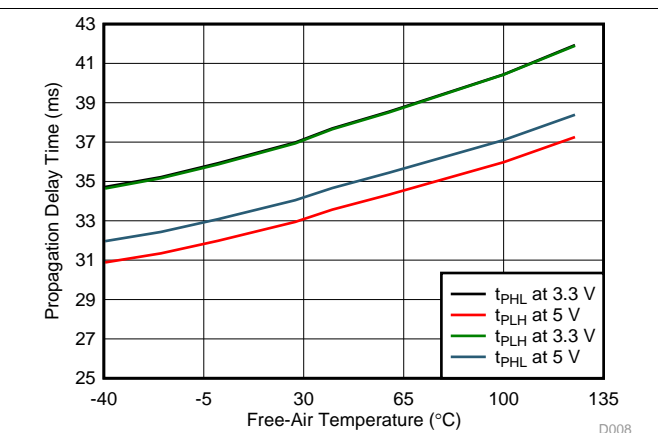

Figure 8. Propagation Delay Time vs Free-Air Temperature

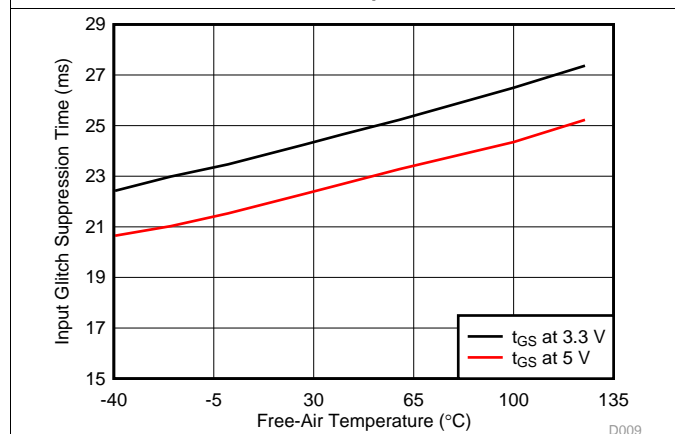

Figure 9. Input Glitch Suppression Time vs Free-Air Temperature

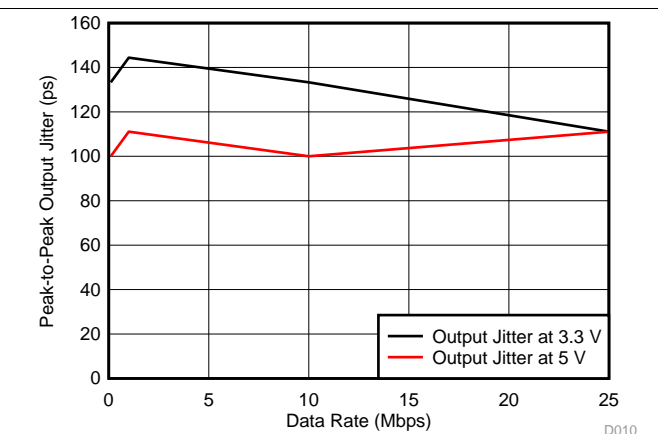
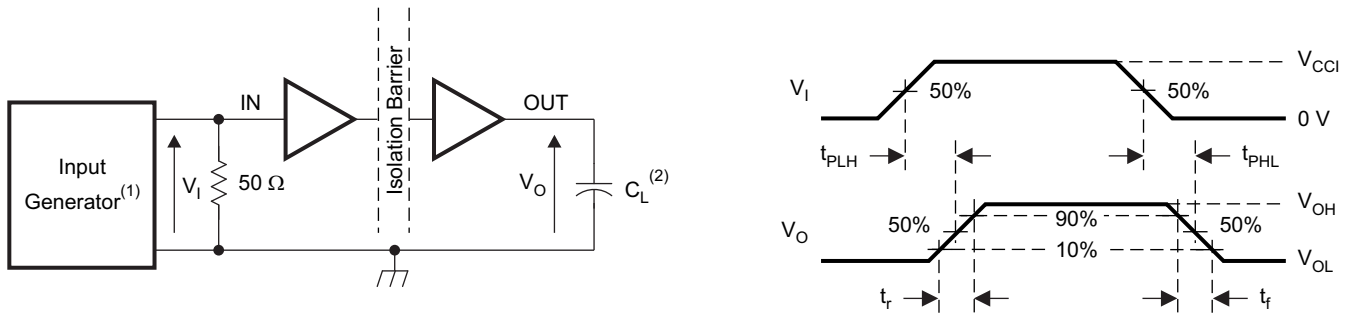

Figure 10. Peak-to-Peak Output Jitter vs Data Rate

## 7 Parameter Measurement Information



- (1) The input pulse is supplied by a generator having the following characteristics: PRR  $\leq$  50 kHz, 50% duty cycle,  $t_r \leq 3$  ns,  $t_f \leq 3$  ns,  $Z_o = 50 \Omega$ . At the input, a 50- $\Omega$  resistor is required to terminate the Input Generator signal. It is not needed in actual application.
- (2)  $C_L = 15$  pF and includes instrumentation and fixture capacitance within  $\pm 20\%$ .

**Figure 11. Switching Characteristic Test Circuit and Voltage Waveforms**

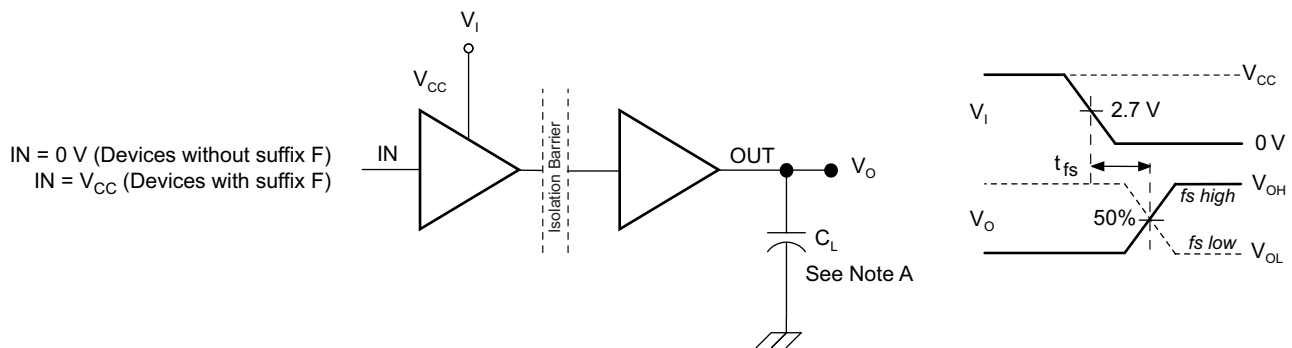

- A.  $C_L = 15$  pF and includes instrumentation and fixture capacitance within  $\pm 20\%$ .

**Figure 12. Fail-Safe Output Delay-Time Test Circuit and Voltage Waveforms**

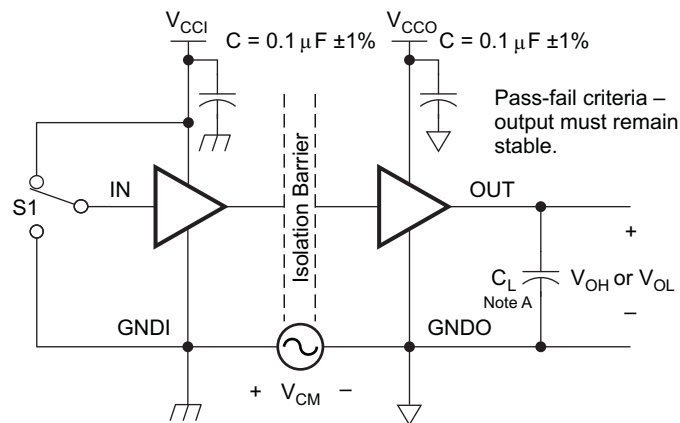

- (1)  $C_L = 15$  pF and includes instrumentation and fixture capacitance within  $\pm 20\%$ .

**Figure 13. Common-Mode Transient Immunity Test Circuit**

## 8 Detailed Description

### 8.1 Overview

The isolator in Figure 14 is based on a capacitive isolation barrier technique. The I/O channel of the device consists of two internal data channels, a high-frequency (HF) channel with a bandwidth from 100 kbps up to 25 Mbps, and a low-frequency (LF) channel covering the range from 100 kbps down to DC.

In principle, a single-ended input signal entering the HF channel is split into a differential signal via the inverter gate at the input. The following capacitor-resistor networks differentiate the signal into transient pulses, which then are converted into CMOS levels by a comparator. The transient pulses at the input of the comparator can be either above or below the common mode voltage  $V_{REF}$  depending on whether the input bit transitions from 0 to 1 or 1 to 0. The comparator threshold is adjusted based on the expected bit transition. A decision logic (DCL) at the output of the HF channel comparator measures the durations between signal transients. If the duration between two consecutive transients exceeds a certain time limit, (as in the case of a low-frequency signal), the DCL forces the output-multiplexer to switch from the high-frequency to the low-frequency channel.

### 8.2 Functional Block Diagram

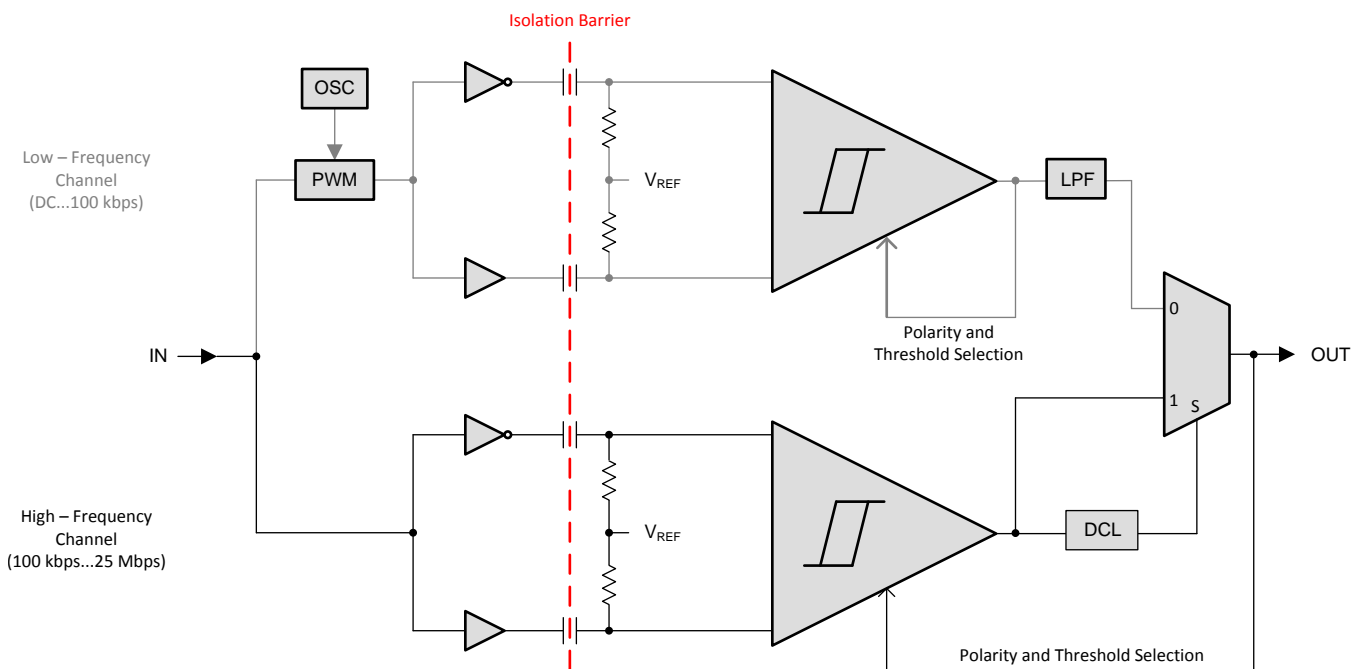

Figure 14. Conceptual Block Diagram of a Digital Capacitive Isolator

Because low-frequency input signals require the internal capacitors to assume prohibitively large values, these signals are pulse-width modulated (PWM) with the carrier frequency of an internal oscillator, thus creating a sufficiently high frequency, capable of passing the capacitive barrier. As the input is modulated, a low-pass filter (LPF) is required to remove the high-frequency carrier from the actual data before passing it on to the output multiplexer.

### 8.3 Feature Description

ORDERABLE DEVICE	CHANNEL DIRECTION	RATED ISOLATION	MAX DATA RATE	DEFAULT OUTPUT
ISO7320CQDQ1 and ISO7320CQDRQ1	Same	3000 V <sub>RMS</sub> / 4242 V <sub>PK</sub> <sup>(1)</sup>	25 Mbps	High
ISO7320FCQDQ1 and ISO7320FCQDRQ1				Low
ISO7321CQDQ1 and ISO7321CQDRQ1	Opposite			High
ISO7321FCQDQ1 and ISO7321FCQDRQ1				Low

(1) See the [Regulatory Information](#) section for detailed Isolation Ratings

#### 8.3.1 High Voltage Feature Description

##### 8.3.1.1 Insulation and Safety-Related Specifications for D-8 Package

over recommended operating conditions (unless otherwise noted)

PARAMETER		TEST CONDITIONS	MIN	TYP	MAX	UNIT
L(I01)	Minimum air gap (clearance)	Shortest terminal-to-terminal distance through air	4			mm
L(I02)	Minimum external tracking (creepage)	Shortest terminal-to-terminal distance across the package surface	4			mm
CTI	Tracking resistance (comparative tracking index)	DIN EN 60112 (VDE 0303-11); IEC 60112	400			V
DTI	Minimum internal gap (internal clearance)	Distance through insulation	13			µm
R <sub>IO</sub>	Isolation resistance, input to output <sup>(1)</sup>	V <sub>IO</sub> = 500 V, T <sub>A</sub> = 25°C	10 <sup>12</sup>			Ω
		V <sub>IO</sub> = 500 V, 100°C ≤ T <sub>A</sub> ≤ 125°C	10 <sup>11</sup>			Ω
C <sub>IO</sub>	Isolation capacitance, input to output <sup>(1)</sup>	V <sub>IO</sub> = 0.4 sin(2πft), f = 1 MHz		1.5		pF
C <sub>I</sub>	Input capacitance <sup>(2)</sup>	V <sub>I</sub> = V <sub>CC</sub> / 2 + 0.4 sin(2πft), f = 1 MHz, V <sub>CC</sub> = 5 V		1.8		pF

(1) All pins on each side of the barrier tied together creating a two-terminal device.

(2) Measured from input pin to ground.

#### NOTE

Creepage and clearance requirements should be applied according to the specific equipment isolation standards of an application. Care should be taken to maintain the creepage and clearance distance of a board design to ensure that the mounting pads of the isolator on the printed-circuit board do not reduce this distance.

Creepage and clearance on a printed-circuit board become equal in certain cases. Techniques such as inserting grooves, ribs, or both on a printed circuit board are used to help increase these specifications.

### 8.3.1.2 Insulation Characteristics

over recommended operating conditions (unless otherwise noted)

PARAMETER <sup>(1)</sup>		TEST CONDITIONS	SPECIFICATION	UNIT
V <sub>IOWM</sub>	Maximum isolation working voltage		400	V <sub>RMS</sub>
V <sub>IORM</sub>	Maximum repetitive peak voltage per DIN V VDE V 0884-10		566	V <sub>PK</sub>
V <sub>PR</sub>	Input-to-output test voltage per DIN V VDE V 0884-10	After Input/Output safety test subgroup 2/3, V <sub>PR</sub> = V <sub>IORM</sub> × 1.2, t = 10 s, Partial discharge < 5 pC	680	V <sub>PK</sub>
		Method a, After environmental tests subgroup 1, V <sub>PR</sub> = V <sub>IORM</sub> × 1.6, t = 10 s, Partial Discharge < 5 pC	906	
		Method b1, V <sub>PR</sub> = V <sub>IORM</sub> × 1.875, t = 1 s (100% Production test) Partial discharge < 5 pC	1062	
V <sub>IOTM</sub>	Maximum transient overvoltage per DIN V VDE V 0884-10	V <sub>TEST</sub> = V <sub>IOTM</sub> t = 60 sec (qualification) t = 1 sec (100% production)	4242	V <sub>PK</sub>
V <sub>IOSM</sub>	Maximum surge isolation voltage per DIN V VDE V 0884-10	Test method per IEC 60065, 1.2/50 μs waveform, V <sub>TEST</sub> = 1.3 × V <sub>IOSM</sub> = 7800 V <sub>PK</sub> (qualification)	6000	V <sub>PK</sub>
V <sub>ISO</sub>	Withstand isolation voltage per UL 1577	V <sub>TEST</sub> = V <sub>ISO</sub> = 3000 V <sub>RMS</sub> , t = 60 sec (qualification); V <sub>TEST</sub> = 1.2 × V <sub>ISO</sub> = 3600 V <sub>RMS</sub> , t = 1 sec (100% production)	3000	V <sub>RMS</sub>
R <sub>S</sub>	Insulation resistance	V <sub>IO</sub> = 500 V at T <sub>S</sub>	>10 <sup>9</sup>	Ω
	Pollution degree		2	

(1) Climatic Classification 40/125/21

**Table 1. IEC 60664-1 Ratings Table**

PARAMETER	TEST CONDITIONS	SPECIFICATION
Basic isolation group	Material group	II
Installation classification	Rated mains voltage ≤ 150 V <sub>RMS</sub>	I–IV
	Rated mains voltage ≤ 300 V <sub>RMS</sub>	I–III

### 8.3.1.3 Regulatory Information

VDE	CSA	UL	CQC
Certified according to DIN V VDE V 0884-10 (VDE V 0884-10):2006-12	Approved under CSA Component Acceptance Notice 5A, IEC 60950-1, and IEC 61010-1	Recognized under UL 1577 Component Recognition Program	Plan to certify according to GB4943.1-2011
Basic Insulation Maximum Transient Overvoltage, 4242 V <sub>PK</sub> Maximum Surge Isolation Voltage, 6000 V <sub>PK</sub> Maximum Repetitive Peak Voltage, 566 V <sub>PK</sub>	400 V <sub>RMS</sub> Basic Insulation and 200 V <sub>RMS</sub> Reinforced Insulation working voltage per CSA 60950-1-07+A1+A2 and IEC 60950-1 2nd Ed.+A1+A2; 300 V <sub>RMS</sub> Basic Insulation working voltage per CSA 61010-1-12 and IEC 61010-1 3rd Ed.	Single protection, 3000 V <sub>RMS</sub> <sup>(1)</sup>	Basic Insulation, Altitude ≤ 5000 m, Tropical Climate, 250 V <sub>RMS</sub> maximum working voltage
Certificate number: 40016131	Master contract number: 220991	File number: E181974	Certification Planned

(1) Production tested ≥ 3600 V<sub>RMS</sub> for 1 second in accordance with UL 1577.

### 8.3.1.4 Safety Limiting Values

Safety limiting intends to minimize potential damage to the isolation barrier upon failure of input or output circuitry. A failure of the I/O can allow low resistance to ground or the supply and, without current limiting, dissipate sufficient power to overheat the die and damage the isolation barrier, potentially leading to secondary system failures.

PARAMETER		TEST CONDITIONS	MIN	TYP	MAX	UNIT
I <sub>S</sub>	Safety input, output, or supply current	R <sub>θJA</sub> = 121 °C/W, V <sub>I</sub> = 5.5 V, T <sub>J</sub> = 150°C, T <sub>A</sub> = 25°C			188	mA
		R <sub>θJA</sub> = 121 °C/W, V <sub>I</sub> = 3.6 V, T <sub>J</sub> = 150°C, T <sub>A</sub> = 25°C			287	
T <sub>S</sub>	Maximum safety temperature				150	°C

The safety-limiting constraint is the absolute-maximum junction temperature specified in the [Absolute Maximum Ratings](#) table. The power dissipation and junction-to-air thermal impedance of the device installed in the application hardware determines the junction temperature. The assumed junction-to-air thermal resistance in the [Thermal Information](#) table is that of a device installed on a High-K Test Board for Leaded Surface-Mount Packages. The power is the recommended maximum input voltage times the current. The junction temperature is then the ambient temperature plus the power times the junction-to-air thermal resistance.

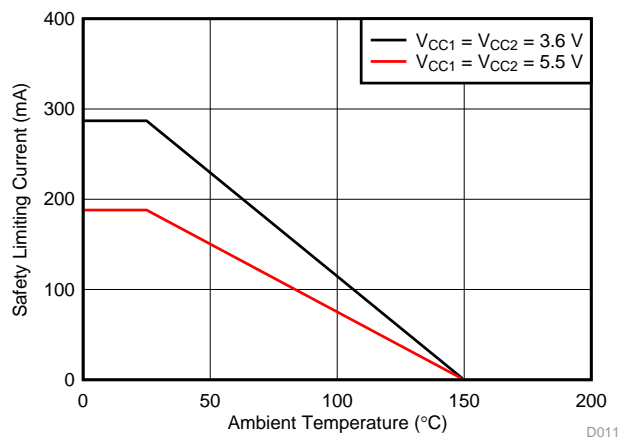

Figure 15. Thermal Derating Curve per VDE

### 8.4 Device Functional Modes

Table 2 lists the functional modes for the ISO732x-Q1 family of devices.

Table 2. Function Table<sup>(1)</sup>

V <sub>CCI</sub>	V <sub>CCO</sub>	INA, INB	OUTA, OUTB	
			ISO732xCQDQ1 AND ISO732xCQDRQ1	ISO732xFCQDQ1 AND ISO732xFCQDRQ1
PU	PU	H	H	H
		L	L	L
		Open	H <sup>(2)</sup>	L <sup>(3)</sup>
PD	PU	X	H <sup>(2)</sup>	L <sup>(3)</sup>
X	PD	X	Undetermined	Undetermined

- (1) V<sub>CCI</sub> = Input-side V<sub>CC</sub>; V<sub>CCO</sub> = Output-side V<sub>CC</sub>; PU = Powered up (V<sub>CC</sub> ≥ 3 V); PD = Powered down (V<sub>CC</sub> ≤ 2.1 V); X = Irrelevant; H = High level; L = Low level; Open = Not connected
- (2) In fail-safe condition, output defaults to high level
- (3) In fail-safe condition, output defaults to low level

#### 8.4.1 Device I/O Schematics

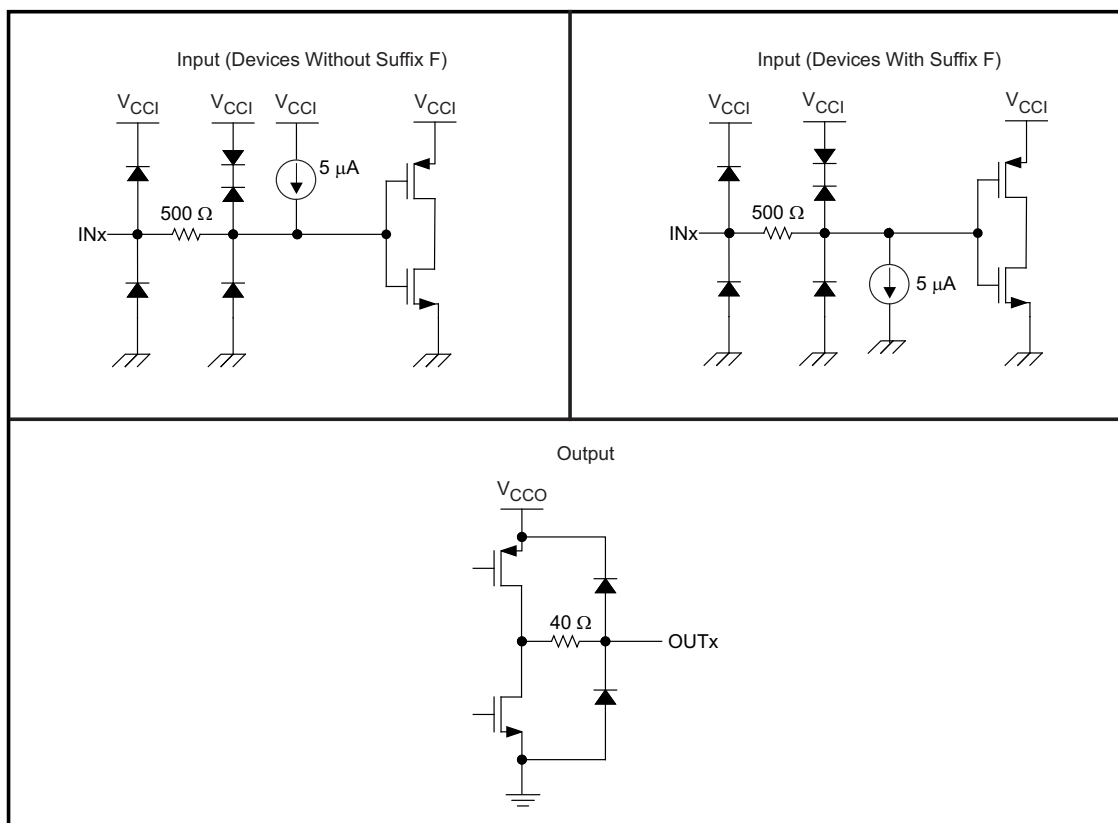

Figure 16. Device I/O Schematics

## 9 Application and Implementation

### NOTE

Information in the following applications sections is not part of the TI component specification, and TI does not warrant its accuracy or completeness. TI's customers are responsible for determining suitability of components for their purposes. Customers should validate and test their design implementation to confirm system functionality.

### 9.1 Application Information

The ISO732x-Q1 family of devices uses single-ended TTL-logic switching technology. The supply voltage range is from 3 V to 5.5 V for both supplies,  $V_{CC1}$  and  $V_{CC2}$ . When designing with digital isolators, keep in mind that because of the single-ended design structure, digital isolators do not conform to any specific interface standard and are only intended for isolating single-ended CMOS or TTL digital signal lines. The isolator is typically placed between the data controller (essentially,  $\mu\text{C}$  or UART), and a data converter or a line transceiver, regardless of the interface type or standard.

### 9.2 Typical Application

The ISO7321-Q1 device can be used with Texas Instruments' Piccolo™ microcontroller, CAN transceiver, transformer driver, and voltage regulator to create an isolated CAN interface.

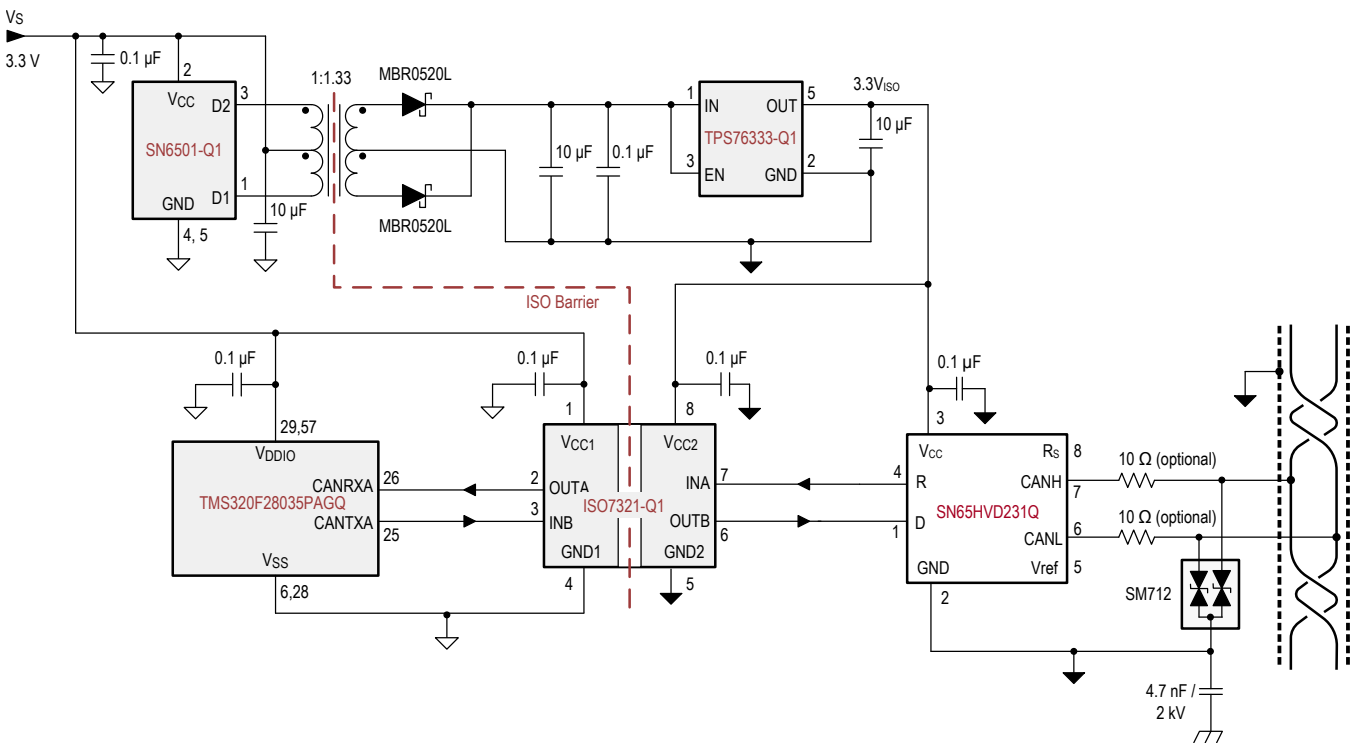

Multiple pins and discrete components omitted for clarity purpose.

**Figure 17. Isolated CAN Interface**

## Typical Application (continued)

### 9.2.1 Design Requirements

#### 9.2.1.1 Typical Supply Current Equations

For the equations in this section, the following is true:

- $I_{CC1}$  and  $I_{CC2}$  are typical supply currents measured in mA
- $f$  is the data rate measured in Mbps
- $C_L$  is the capacitive load measured in pF

##### 9.2.1.1.1 ISO7320-Q1

At  $V_{CC1} = V_{CC2} = 5\text{ V}$

$$I_{CC1} = 0.3838 + (0.0431 \times f) \quad (1)$$

$$I_{CC2} = 2.74567 + (0.08433 \times f) + (0.01 \times f \times C_L) \quad (2)$$

At  $V_{CC1} = V_{CC2} = 3.3\text{ V}$

$$I_{CC1} = 0.2394 + (0.02355 \times f) \quad (3)$$

$$I_{CC2} = 2.10681 + (0.04374 \times f) + (0.007045 \times f \times C_L) \quad (4)$$

##### 9.2.1.1.2 ISO7321-Q1

At  $V_{CC1} = V_{CC2} = 5\text{ V}$

$$I_{CC1} \text{ and } I_{CC2} = 1.5877 + (0.066 \times f) + (0.00123 \times f \times C_L) \quad (5)$$

At  $V_{CC1} = V_{CC2} = 3.3\text{ V}$

$$I_{CC1} \text{ and } I_{CC2} = 1.187572 + (0.019399 \times f) + (0.0019029 \times f \times C_L) \quad (6)$$

### 9.2.2 Detailed Design Procedure

#### 9.2.2.1 Electromagnetic Compatibility (EMC) Considerations

Many applications in harsh industrial environment are sensitive to disturbances such as electrostatic discharge (ESD), electrical fast transient (EFT), surge and electromagnetic emissions. These electromagnetic disturbances are regulated by international standards such as IEC 61000-4-x and CISPR 22. Although system-level performance and reliability depends, to a large extent, on the application board design and layout, the ISO732x-Q1 family of devices incorporates many chip-level design improvements for overall system robustness. Some of these improvements include:

- Robust ESD protection cells for input and output signal pins and inter-chip bond pads.
- Low-resistance connectivity of ESD cells to supply and ground pins.
- Enhanced performance of high voltage isolation capacitor for better tolerance of ESD, EFT and surge events.
- Bigger on-chip decoupling capacitors to bypass undesirable high energy signals through a low impedance path.
- PMOS and NMOS devices isolated from each other by using guard rings to avoid triggering of parasitic SCRs.
- Reduced common mode currents across the isolation barrier by ensuring purely differential internal operation.

## Typical Application (continued)

### 9.2.3 Application Curves

The following typical eye diagrams of the ISO732x-Q1 family of devices indicate low jitter and wide open eye at the maximum data rate of 25 Mbps.

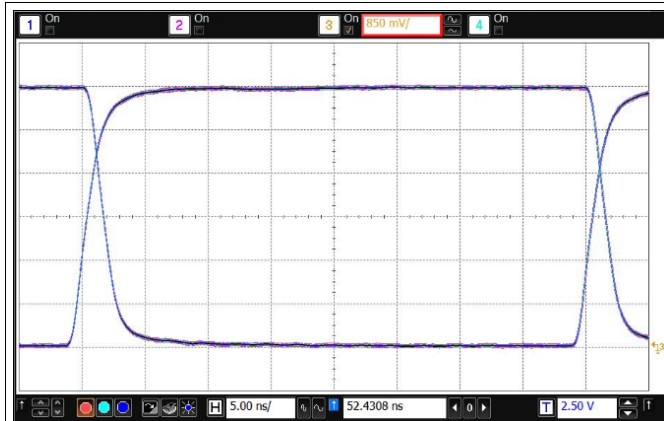

Figure 18. Eye Diagram at 25 Mbps, 5 V and 25°C

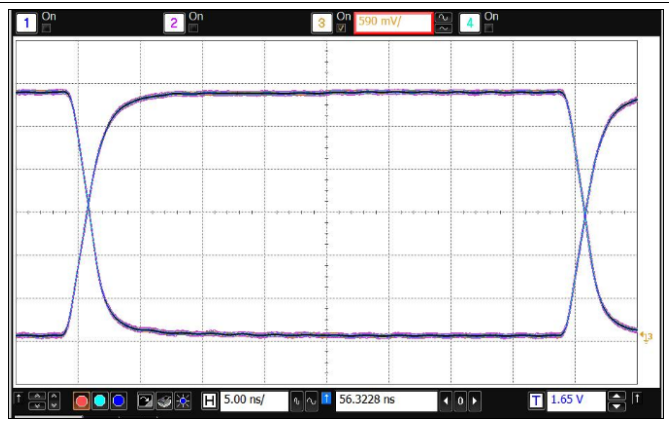

Figure 19. Eye Diagram at 25 Mbps, 3.3 V and 25°C

## 10 Power Supply Recommendations

To help ensure reliable operation at data rates and supply voltages, a 0.1- $\mu$ F bypass capacitor is recommended at the input and output supply pins ( $V_{CC1}$  and  $V_{CC2}$ ). The capacitors should be placed as close to the supply pins as possible. If only a single primary-side power supply is available in an application, isolated power can be generated for the secondary-side with the help of a transformer driver such as Texas Instruments' [SN6501-Q1](#). For such applications, detailed power supply design and transformer selection recommendations are available in the [SN6501-Q1](#) datasheet ([SLLSEF3](#)).

## 11 Layout

### 11.1 Layout Guidelines

A minimum of four layers is required to accomplish a low EMI PCB design (see [Figure 20](#)). Layer stacking should be in the following order (top-to-bottom): high-speed signal layer, ground plane, power plane and low-frequency signal layer.

- Routing the high-speed traces on the top layer avoids the use of vias (and the introduction of their inductances) and allows for clean interconnects between the isolator and the transmitter and receiver circuits of the data link.
- Placing a solid ground plane next to the high-speed signal layer establishes controlled impedance for transmission line interconnects and provides an excellent low-inductance path for the return current flow.
- Placing the power plane next to the ground plane creates additional high-frequency bypass capacitance of approximately 100 pF/in<sup>2</sup>.
- Routing the slower speed control signals on the bottom layer allows for greater flexibility as these signal links usually have margin to tolerate discontinuities such as vias.

If an additional supply voltage plane or signal layer is needed, add a second power or ground plane system to the stack to keep it symmetrical. This makes the stack mechanically stable and prevents it from warping. Also the power and ground plane of each power system can be placed closer together, thus increasing the high-frequency bypass capacitance significantly.

For detailed layout recommendations, see the application note, *Digital Isolator Design Guide*, [SLLA284](#).

## Layout Guidelines (continued)

### 11.1.1 PCB Material

For digital circuit boards operating below 150 Mbps, (or rise and fall times higher than 1 ns), and trace lengths of up to 10 inches, use standard FR-4 UL94V-0 printed circuit board. This type of PCB is preferred over cheaper alternatives because of lower dielectric losses at high frequencies, less moisture absorption, greater strength and stiffness, and self-extinguishing flammability-characteristics.

### 11.2 Layout Example

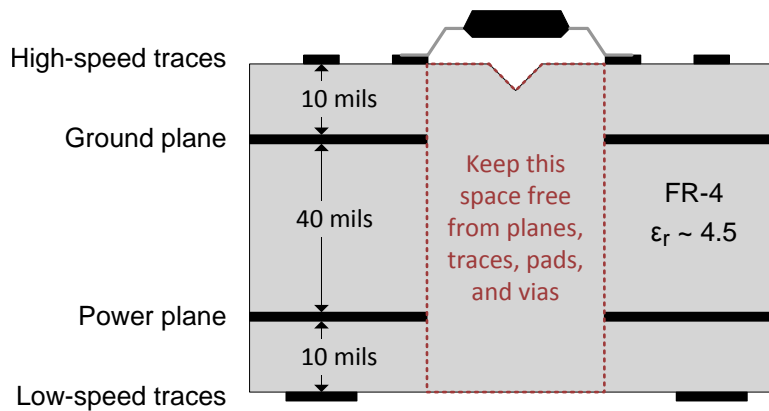

Figure 20. Recommended Layer Stack

## 12 器件和文档支持

### 12.1 文档支持

#### 12.1.1 相关文档

相关文档如下：

- 《数字隔离器设计指南》， [SLLA284](#)
- 《隔离相关术语》， [SLLA353](#)
- 《SN6501-Q1 用于隔离电源的变压器驱动器》， [SLLSEF3](#)
- 《SN65HVD231Q-Q1 3.3V CAN 收发器》， [SGLS398](#)
- 《TMS320F28035 Piccolo™ 微控制器》， [SPRS584](#)
- 《TPS76333-Q1 低功耗 150mA 低压降线性稳压器》， [SGLS247](#)

### 12.2 相关链接

以下表格列出了快速访问链接。范围包括技术文档、支持与社区资源、工具和软件，并且可以快速访问样片或购买链接。

表 3. 相关链接

器件	产品文件夹	样片与购买	技术文章	工具与软件	支持与社区
ISO7320-Q1	<a href="#">请单击此处</a>	<a href="#">请单击此处</a>	<a href="#">请单击此处</a>	<a href="#">请单击此处</a>	<a href="#">请单击此处</a>
ISO7321-Q1	<a href="#">请单击此处</a>	<a href="#">请单击此处</a>	<a href="#">请单击此处</a>	<a href="#">请单击此处</a>	<a href="#">请单击此处</a>

### 12.3 社区资源

The following links connect to TI community resources. Linked contents are provided "AS IS" by the respective contributors. They do not constitute TI specifications and do not necessarily reflect TI's views; see TI's [Terms of Use](#).

**TI E2E™ Online Community** *TI's Engineer-to-Engineer (E2E) Community*. Created to foster collaboration among engineers. At [e2e.ti.com](#), you can ask questions, share knowledge, explore ideas and help solve problems with fellow engineers.

**Design Support** *TI's Design Support* Quickly find helpful E2E forums along with design support tools and contact information for technical support.

### 12.4 商标

DeviceNet, Piccolo, E2E are trademarks of Texas Instruments.  
All other trademarks are the property of their respective owners.

### 12.5 静电放电警告



这些装置包含有限的内置 ESD 保护。存储或装卸时，应将导线一起截短或将装置放置于导电泡棉中，以防止 MOS 门极遭受静电损伤。

### 12.6 Glossary

[SLYZ022](#) — *TI Glossary*.

This glossary lists and explains terms, acronyms, and definitions.

## 13 机械、封装和可订购信息

以下页中包括机械、封装和可订购信息。 这些信息是针对指定器件可提供的最新数据。 这些数据会在无通知且不对本文档进行修订的情况下发生改变。 欲获得该数据表的浏览器版本，请查阅左侧的导航栏。



**D0008B**

**PACKAGE OUTLINE**  
**SOIC - 1.75 mm max height**

SOIC

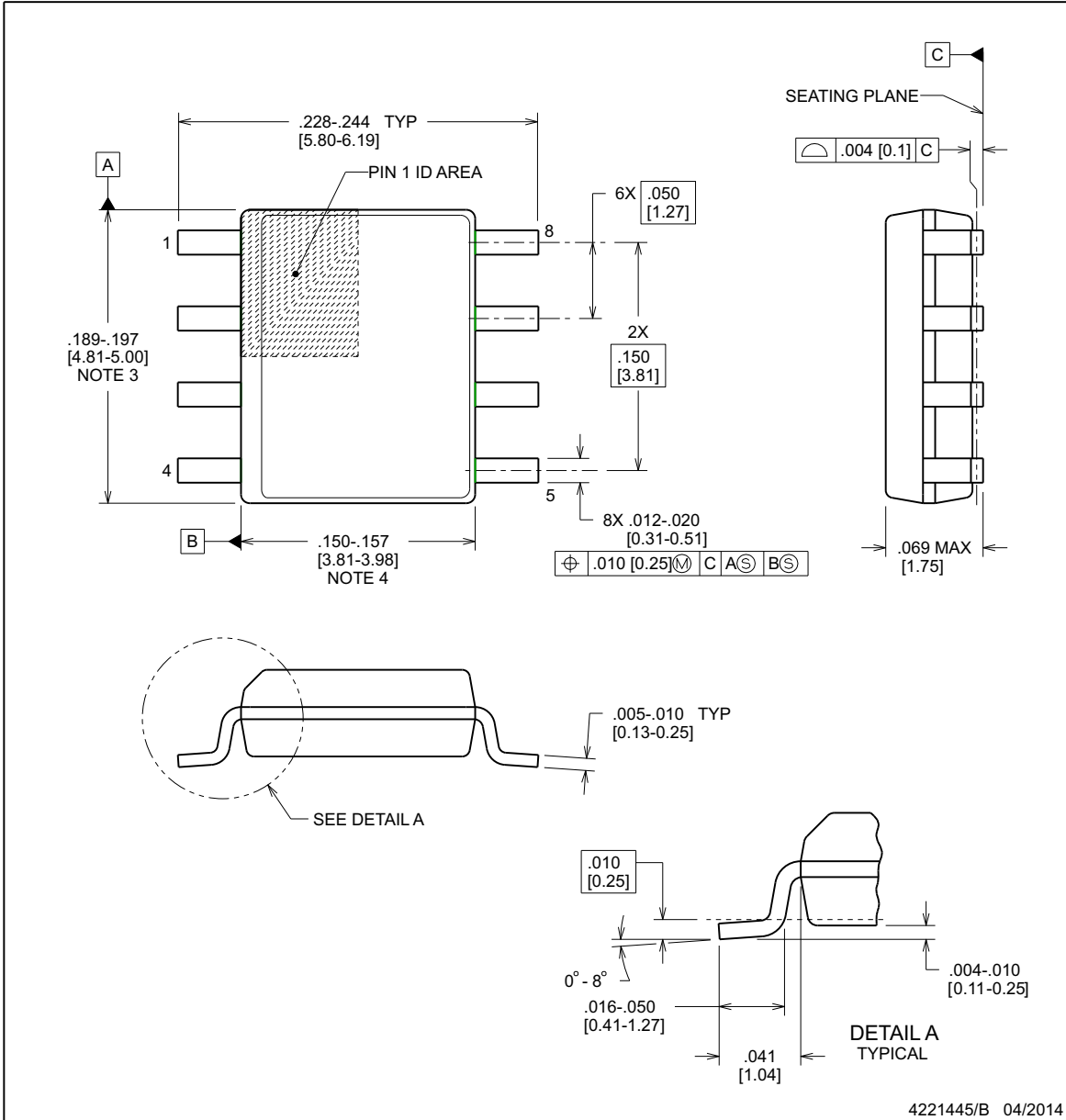

NOTES:

1. Linear dimensions are in inches [millimeters]. Dimensions in parenthesis are for reference only. Controlling dimensions are in inches. Dimensioning and tolerancing per ASME Y14.5M.
2. This drawing is subject to change without notice.
3. This dimension does not include mold flash, protrusions, or gate burrs. Mold flash, protrusions, or gate burrs shall not exceed  $.006$  [0.15], per side.
4. This dimension does not include interlead flash.
5. Reference JEDEC registration MS-012, variation AA.

## EXAMPLE BOARD LAYOUT

**D0008B**

**SOIC - 1.75 mm max height**

SOIC

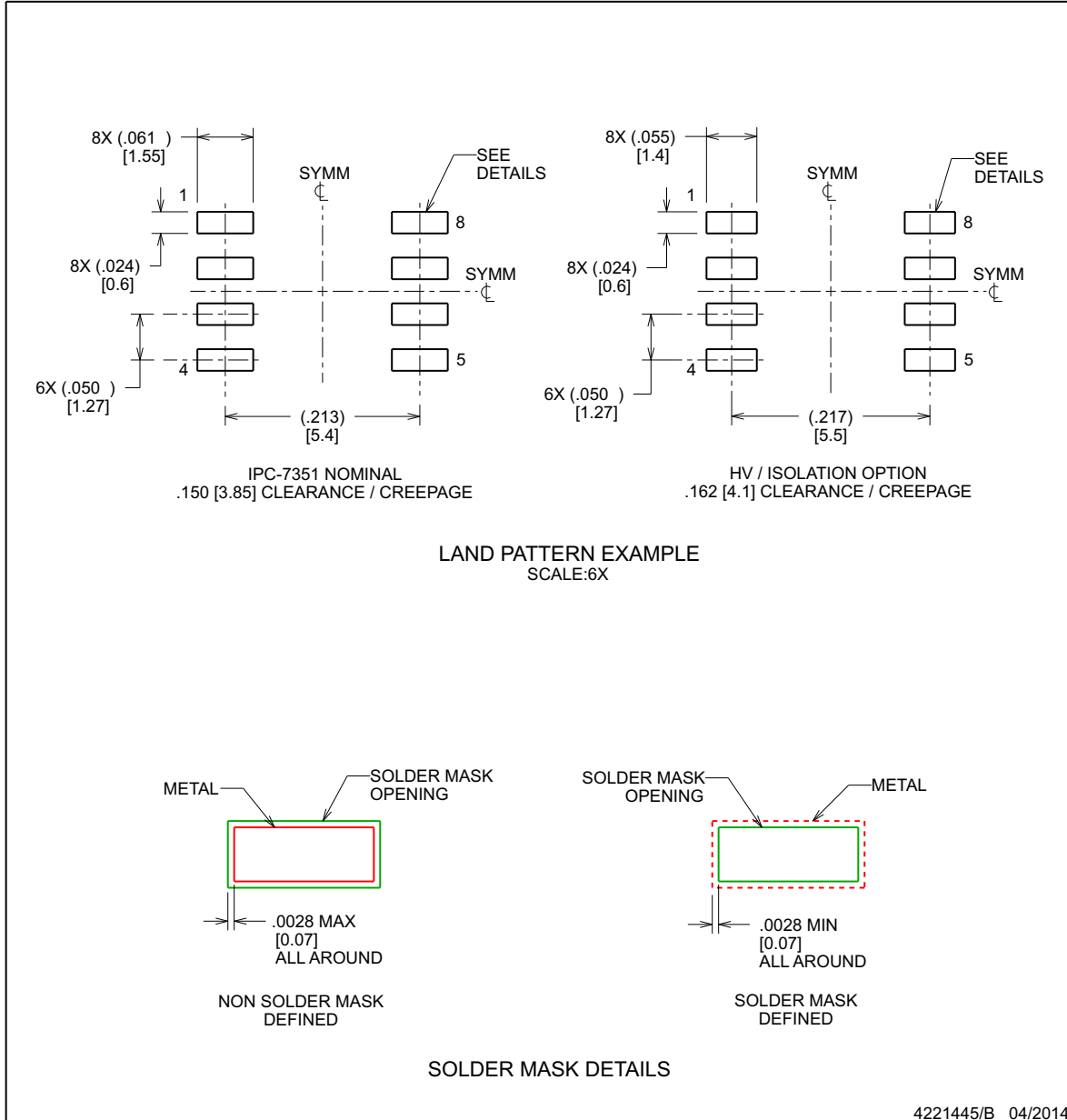

NOTES: (continued)

- Publication IPC-7351 may have alternate designs.
- Solder mask tolerances between and around signal pads can vary based on board fabrication site.

## EXAMPLE STENCIL DESIGN

**D0008B**

**SOIC - 1.75 mm max height**

SOIC

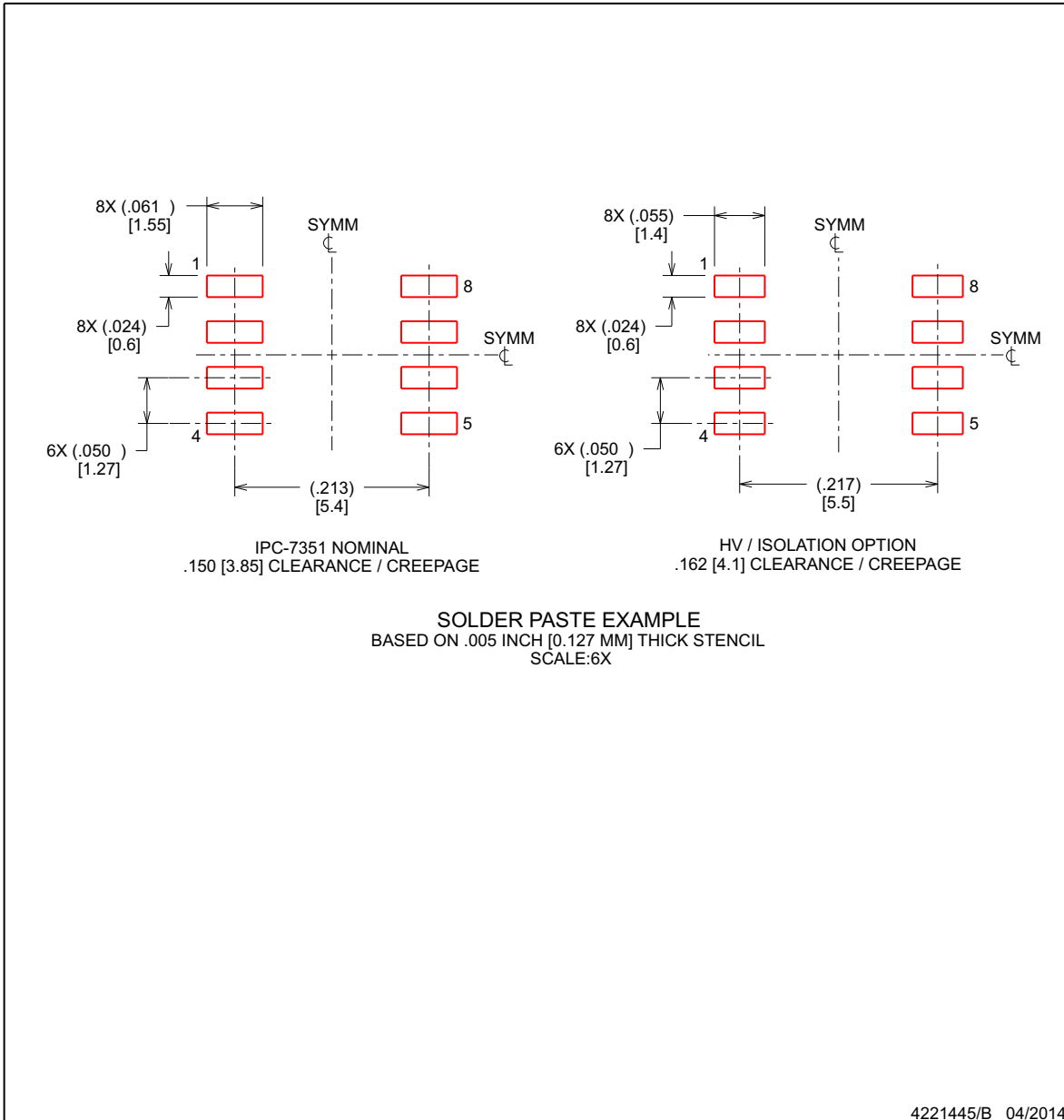

NOTES: (continued)

- 8. Laser cutting apertures with trapezoidal walls and rounded corners may offer better paste release. IPC-7525 may have alternate design recommendations.
- 9. Board assembly site may have different recommendations for stencil design.

## 重要声明

德州仪器(TI)及其下属子公司有权根据 JESD46 最新标准,对所提供的产品和服务进行更正、修改、增强、改进或其它更改,并有权根据 JESD48 最新标准中止提供任何产品和服务。客户在下订单前应获取最新的相关信息,并验证这些信息是否完整且是最新的。所有产品的销售都遵循在订单确认时所提供的TI 销售条款与条件。

TI 保证其所销售的组件的性能符合产品销售时 TI 半导体产品销售条件与条款的适用规范。仅在 TI 保证的范围内,且 TI 认为有必要时才会使用测试或其它质量控制技术。除非适用法律做出了硬性规定,否则没有必要对每种组件的所有参数进行测试。

TI 对应用帮助或客户产品设计不承担任何义务。客户应对其使用 TI 组件的产品和应用自行负责。为尽量减小与客户产品和应用相关的风险,客户应提供充分的设计与操作安全措施。

TI 不对任何 TI 专利权、版权、屏蔽作品权或其它与使用了 TI 组件或服务的组合设备、机器或流程相关的 TI 知识产权中授予的直接或隐含权限作出任何保证或解释。TI 所发布的与第三方产品或服务有关的信息,不能构成从 TI 获得使用这些产品或服务的许可、授权、或认可。使用此类信息可能需要获得第三方的专利权或其它知识产权方面的许可,或是 TI 的专利权或其它知识产权方面的许可。

对于 TI 的产品手册或数据表中 TI 信息的重要部分,仅在没有对内容进行任何篡改且带有相关授权、条件、限制和声明的情况下才允许进行复制。TI 对此类篡改过的文件不承担任何责任或义务。复制第三方的信息可能需要服从额外的限制条件。

在转售 TI 组件或服务时,如果对该组件或服务参数的陈述与 TI 标明的参数相比存在差异或虚假成分,则会失去相关 TI 组件或服务的所有明示或暗示授权,且这是不正当的、欺诈性商业行为。TI 对任何此类虚假陈述均不承担任何责任或义务。

客户认可并同意,尽管任何应用相关信息或支持仍可能由 TI 提供,但他们将独立负责满足与其产品及其在应用中使用的 TI 产品相关的所有法律、法规和安全相关要求。客户声明并同意,他们具备制定与实施安全措施所需的全部专业技术和知识,可预见故障的危险后果、监测故障及其后果、降低有可能造成人身伤害的故障的发生机率并采取适当的补救措施。客户将全额赔偿因在此类安全关键应用中使用任何 TI 组件而对 TI 及其代理造成的任何损失。

在某些场合中,为了推进安全相关应用有可能对 TI 组件进行特别的促销。TI 的目标是利用此类组件帮助客户设计和创立其特有的可满足适用的功能安全性标准和要求的终端产品解决方案。尽管如此,此类组件仍然服从这些条款。

TI 组件未获得用于 FDA Class III (或类似的生命攸关医疗设备)的授权许可,除非各方授权官员已经达成了专门管控此类使用的特别协议。

只有那些 TI 特别注明属于军用等级或“增强型塑料”的 TI 组件才是设计或专门用于军事/航空应用或环境的。购买者认可并同意,对并非指定面向军事或航空航天用途的 TI 组件进行军事或航空航天方面的应用,其风险由客户单独承担,并且由客户独立负责满足与此类使用相关的所有法律和法规要求。

TI 已明确指定符合 ISO/TS16949 要求的产品,这些产品主要用于汽车。在任何情况下,因使用非指定产品而无法达到 ISO/TS16949 要求, TI 不承担任何责任。

	产品		应用
数字音频	<a href="http://www.ti.com.cn/audio">www.ti.com.cn/audio</a>	通信与电信	<a href="http://www.ti.com.cn/telecom">www.ti.com.cn/telecom</a>
放大器和线性器件	<a href="http://www.ti.com.cn/amplifiers">www.ti.com.cn/amplifiers</a>	计算机及周边	<a href="http://www.ti.com.cn/computer">www.ti.com.cn/computer</a>
数据转换器	<a href="http://www.ti.com.cn/dataconverters">www.ti.com.cn/dataconverters</a>	消费电子	<a href="http://www.ti.com.cn/consumer-apps">www.ti.com.cn/consumer-apps</a>
DLP® 产品	<a href="http://www.dlp.com">www.dlp.com</a>	能源	<a href="http://www.ti.com.cn/energy">www.ti.com.cn/energy</a>
DSP - 数字信号处理器	<a href="http://www.ti.com.cn/dsp">www.ti.com.cn/dsp</a>	工业应用	<a href="http://www.ti.com.cn/industrial">www.ti.com.cn/industrial</a>
时钟和计时器	<a href="http://www.ti.com.cn/clockandtimers">www.ti.com.cn/clockandtimers</a>	医疗电子	<a href="http://www.ti.com.cn/medical">www.ti.com.cn/medical</a>
接口	<a href="http://www.ti.com.cn/interface">www.ti.com.cn/interface</a>	安防应用	<a href="http://www.ti.com.cn/security">www.ti.com.cn/security</a>
逻辑	<a href="http://www.ti.com.cn/logic">www.ti.com.cn/logic</a>	汽车电子	<a href="http://www.ti.com.cn/automotive">www.ti.com.cn/automotive</a>
电源管理	<a href="http://www.ti.com.cn/power">www.ti.com.cn/power</a>	视频和影像	<a href="http://www.ti.com.cn/video">www.ti.com.cn/video</a>
微控制器 (MCU)	<a href="http://www.ti.com.cn/microcontrollers">www.ti.com.cn/microcontrollers</a>		
RFID 系统	<a href="http://www.ti.com.cn/rfidsys">www.ti.com.cn/rfidsys</a>		
OMAP应用处理器	<a href="http://www.ti.com/omap">www.ti.com/omap</a>		
无线连通性	<a href="http://www.ti.com.cn/wirelessconnectivity">www.ti.com.cn/wirelessconnectivity</a>	德州仪器在线技术支持社区	<a href="http://www.deyisupport.com">www.deyisupport.com</a>

邮寄地址: 上海市浦东新区世纪大道1568号, 中建大厦32楼邮政编码: 200122  
Copyright © 2016, 德州仪器半导体技术(上海)有限公司

**PACKAGING INFORMATION**

Orderable Device	Status (1)	Package Type	Package Drawing	Pins	Package Qty	Eco Plan (2)	Lead finish/ Ball material (6)	MSL Peak Temp (3)	Op Temp (°C)	Device Marking (4/5)	Samples
ISO7320CQDQ1	ACTIVE	SOIC	D	8	75	RoHS & Green	NIPDAU	Level-2-260C-1 YEAR	-40 to 125	7320Q	<a href="#">Samples</a>
ISO7320CQDRQ1	ACTIVE	SOIC	D	8	2500	RoHS & Green	NIPDAU	Level-2-260C-1 YEAR	-40 to 125	7320Q	<a href="#">Samples</a>
ISO7320FCQDQ1	ACTIVE	SOIC	D	8	75	RoHS & Green	NIPDAU	Level-2-260C-1 YEAR	-40 to 125	7320FQ	<a href="#">Samples</a>
ISO7320FCQDRQ1	ACTIVE	SOIC	D	8	2500	RoHS & Green	NIPDAU	Level-2-260C-1 YEAR	-40 to 125	7320FQ	<a href="#">Samples</a>
ISO7321CQDQ1	ACTIVE	SOIC	D	8	75	RoHS & Green	NIPDAU	Level-2-260C-1 YEAR	-40 to 125	7321Q	<a href="#">Samples</a>
ISO7321CQDRQ1	ACTIVE	SOIC	D	8	2500	RoHS & Green	NIPDAU	Level-2-260C-1 YEAR	-40 to 125	7321Q	<a href="#">Samples</a>
ISO7321FCQDQ1	ACTIVE	SOIC	D	8	75	RoHS & Green	NIPDAU	Level-2-260C-1 YEAR	-40 to 125	7321FQ	<a href="#">Samples</a>
ISO7321FCQDRQ1	ACTIVE	SOIC	D	8	2500	RoHS & Green	NIPDAU	Level-2-260C-1 YEAR	-40 to 125	7321FQ	<a href="#">Samples</a>

(1) The marketing status values are defined as follows:

**ACTIVE:** Product device recommended for new designs.

**LIFEBUY:** TI has announced that the device will be discontinued, and a lifetime-buy period is in effect.

**NRND:** Not recommended for new designs. Device is in production to support existing customers, but TI does not recommend using this part in a new design.

**PREVIEW:** Device has been announced but is not in production. Samples may or may not be available.

**OBSELETE:** TI has discontinued the production of the device.

(2) **RoHS:** TI defines "RoHS" to mean semiconductor products that are compliant with the current EU RoHS requirements for all 10 RoHS substances, including the requirement that RoHS substance do not exceed 0.1% by weight in homogeneous materials. Where designed to be soldered at high temperatures, "RoHS" products are suitable for use in specified lead-free processes. TI may reference these types of products as "Pb-Free".

**RoHS Exempt:** TI defines "RoHS Exempt" to mean products that contain lead but are compliant with EU RoHS pursuant to a specific EU RoHS exemption.

**Green:** TI defines "Green" to mean the content of Chlorine (Cl) and Bromine (Br) based flame retardants meet JS709B low halogen requirements of <=1000ppm threshold. Antimony trioxide based flame retardants must also meet the <=1000ppm threshold requirement.

(3) MSL, Peak Temp. - The Moisture Sensitivity Level rating according to the JEDEC industry standard classifications, and peak solder temperature.

(4) There may be additional marking, which relates to the logo, the lot trace code information, or the environmental category on the device.

(5) Multiple Device Markings will be inside parentheses. Only one Device Marking contained in parentheses and separated by a "~" will appear on a device. If a line is indented then it is a continuation of the previous line and the two combined represent the entire Device Marking for that device.

<sup>(6)</sup> Lead finish/Ball material - Orderable Devices may have multiple material finish options. Finish options are separated by a vertical ruled line. Lead finish/Ball material values may wrap to two lines if the finish value exceeds the maximum column width.

**Important Information and Disclaimer:** The information provided on this page represents TI's knowledge and belief as of the date that it is provided. TI bases its knowledge and belief on information provided by third parties, and makes no representation or warranty as to the accuracy of such information. Efforts are underway to better integrate information from third parties. TI has taken and continues to take reasonable steps to provide representative and accurate information but may not have conducted destructive testing or chemical analysis on incoming materials and chemicals. TI and TI suppliers consider certain information to be proprietary, and thus CAS numbers and other limited information may not be available for release.

In no event shall TI's liability arising out of such information exceed the total purchase price of the TI part(s) at issue in this document sold by TI to Customer on an annual basis.

## 重要声明和免责声明

TI 均以“原样”提供技术性 & 可靠性数据（包括数据表）、设计资源（包括参考设计）、应用或其他设计建议、网络工具、安全信息和其他资源，不保证其中不含任何瑕疵，且不做任何明示或暗示的担保，包括但不限于对适销性、适合某特定用途或不侵犯任何第三方知识产权的暗示担保。

所述资源可供专业开发人员应用 TI 产品进行设计使用。您将对以下行为独自承担全部责任：(1) 针对您的应用选择合适的 TI 产品；(2) 设计、验证并测试您的应用；(3) 确保您的应用满足相应标准以及任何其他安全、安保或其他要求。所述资源如有变更，恕不另行通知。TI 对您使用所述资源的授权仅限于开发资源所涉及 TI 产品的相关应用。除此之外不得复制或展示所述资源，也不提供其它 TI 或任何第三方的知识产权授权许可。如因使用所述资源而产生任何索赔、赔偿、成本、损失及债务等，TI 对此概不负责，并且您须赔偿由此对 TI 及其代表造成的损害。

TI 所提供产品均受 TI 的销售条款 (<http://www.ti.com.cn/zh-cn/legal/termsofsale.html>) 以及 [ti.com.cn](http://www.ti.com.cn) 上或随附 TI 产品提供的其他可适用条款的约束。TI 提供所述资源并不扩展或以其他方式更改 TI 针对 TI 产品所发布的可适用的担保范围或担保免责声明。

邮寄地址：上海市浦东新区世纪大道 1568 号中建大厦 32 楼，邮政编码：200122

Copyright © 2020 德州仪器半导体技术（上海）有限公司