

LDC1101 1.8V 高分辨率、高速电感数字转换器

1 特性

- 宽工作电压范围：1.8V 至 3.3V
- 传感器频率范围：500kHz 至 10MHz
- R_p 分辨率：16 位
- L 分辨率：16/24 位
- 180kSPS 转换速率
- 阈值检测功能
- R_p 测量的器件间偏差为 1%
- 电源电流：
 - 关断模式下为 1.4 μ A
 - 休眠模式下为 135 μ A
 - 激活模式下为 1.9mA（未连接传感器）
- 距离分辨率可达亚微米级
- 支持远程放置传感器，以便将 LDC 与恶劣环境隔离
- 可防水、油、污垢、灰尘等环境干扰
- 外部组件数极少
- 无磁体操作
- 工作温度范围：-40°C 至 125°C

2 应用

- 高速轮齿计数
- 高速事件计数
- 电机转速感测
- 家用电器、汽车和消费类应用中的旋钮和拨盘
- 家用电器、汽车和消费类应用中的人机界面 (HMI)
- 按钮和键盘
- 电机控制
- 金属探测

4 简化电路原理图

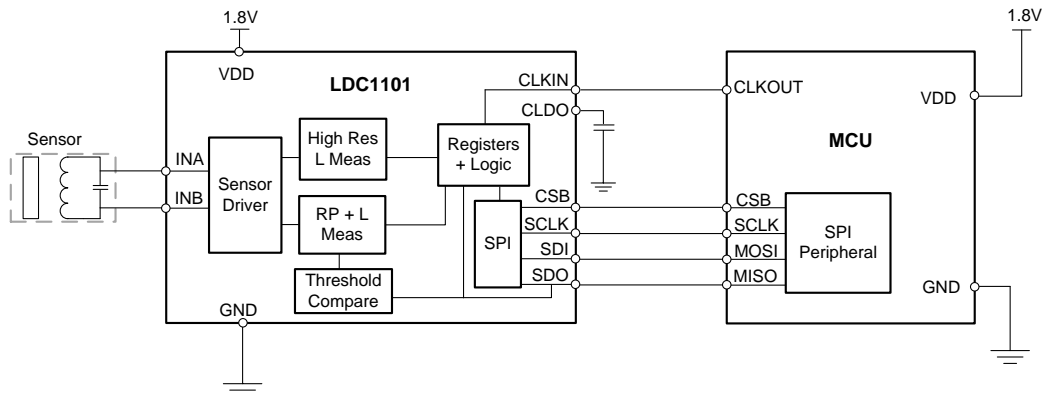

3 说明

LDC1101 是一款 1.8V 至 3.3V、高分辨率电感数字转换器，可对位置、旋转或运动进行短距离、高速、无触点感测，即使存在污垢或灰尘也能够实现可靠、精确的测量，非常适合户外或严苛环境。

LDC1101 特有双感应测量内核，可在执行 > 150kSPS 的 16 位 R_p 和 L 测量的同时，进行分辨率高达 24 位的高分辨率 L 测量，采样速率可高达 180kSPS 以上。LDC1101 包含阈值比较功能，该功能可在器件运行时动态更新。

电感感测技术可实现对线性/角位置、位移、运动、压缩、振动、金属成分以及市面上包括汽车、消费类、计算机、工业、医疗和通信应用在内的很多其他应用的高精度测量。电感感测技术能够以低于其他竞争对手解决方案的成本提供更为出色的性能和可靠性。

LDC1101 在小型 3mm × 3mm 10 引脚 VSON 封装内即可提供这些电感感测技术优势。微控制器可使用 4 引脚 SPI™轻松配置 LDC1101。

器件信息⁽¹⁾

器件型号	封装	封装尺寸 (标称值)
LDC1101	VSON (10)	3.00mm × 3.00mm

(1) 如需了解所有可用封装，请见数据表末尾的可订购产品附录。



目录

1	特性	1	8.4	Device Functional Modes	10
2	应用	1	8.5	Programming	12
3	说明	1	8.6	Register Maps	14
4	简化电路原理图	1	9	Application and Implementation	29
5	修订历史记录	2	9.1	Application Information	29
6	Pin Configuration and Functions	3	9.2	Typical Application	39
7	Specifications	4	10	Power Supply Recommendations	44
7.1	Absolute Maximum Ratings	4	11	Layout	44
7.2	ESD Ratings	4	11.1	Layout Guidelines	44
7.3	Recommended Operating Conditions	4	11.2	Layout Example	45
7.4	Thermal Information	4	12	器件和文档支持	46
7.5	Electrical Characteristics	5	12.1	器件支持	46
7.6	Digital Interface	5	12.2	文档支持	46
7.7	Timing Requirements	6	12.3	社区资源	46
7.8	Typical Characteristics	7	12.4	商标	46
8	Detailed Description	9	12.5	静电放电警告	46
8.1	Overview	9	12.6	术语表	46
8.2	Functional Block Diagram	9	13	机械、封装和可订购信息	46
8.3	Feature Description	9			

5 修订历史记录

Changes from Original (May 2015) to Revision A

Page

•	已添加 完整数据表以替代产品预览	1
---	------------------------	----------

6 Pin Configuration and Functions

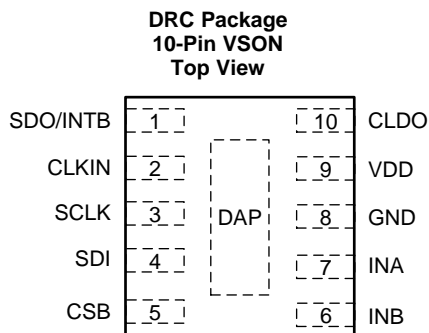

Pin Functions

PIN		TYPE ⁽¹⁾	DESCRIPTION
NAME	NO.		
CLDO	10	P	Internal LDO bypassing pin. A 15 nF capacitor must be connected from this pin to GND.
CLKIN	2	I	External time-base Clock Input
CSB	5	I	SPI CSB. Multiple devices can be connected on the same SPI bus and CSB can be used to uniquely select desired device
DAP	–	–	Connect to Ground for improved thermal performance ⁽²⁾
GND	8	G	Ground
INA	7	A	External LC tank – connected to external LC tank
INB	6	A	External LC tank – connected to external LC tank
SCLK	3	I	SPI Clock Input
SDI	4	I	SPI Data Input – connect to MOSI of SPI master
SDO/INTB	1	O	SPI Data Output/INTB – Connect to MISO of SPI Master. When CSB is high, this pin is High-Z. Alternatively, this pin can be configured to function as INTB
VDD	9	P	Power Supply

(1) P= Power, G=Ground, I=Input, O=Output, A=Analog

(2) There is an internal electrical connection between the exposed Die Attach Pad (DAP) and the GND pin of the device. Although the DAP can be left floating, for best performance the DAP should be connected to the same potential as the device's GND pin. Do not use the DAP as the primary ground for the device. The device GND pin must always be connected to ground.

7 Specifications

7.1 Absolute Maximum Ratings

over operating free-air temperature range (unless otherwise noted)⁽¹⁾

		MIN	MAX	UNIT
V _{DD}	Supply voltage range		3.6	V
V _i	Voltage on INA, INB	-0.3	2.3	V
	Voltage on CLDO	-0.3	1.9	V
Voltage on any other pin ⁽²⁾		-0.3	V _{DD} +0.3	V
T _J	Junction temperature	-55	125	°C
T _{stg}	Storage temperature	-65	125	°C

- (1) Stresses beyond those listed under *Absolute Maximum Ratings* may cause permanent damage to the device. These are stress ratings only, which do not imply functional operation of the device at these or any other conditions beyond those indicated under *Recommended Operating Conditions*. Exposure to absolute-maximum-rated conditions for extended periods may affect device reliability.
- (2) Maximum voltage across any two pins is V_{DD}+0.3.

7.2 ESD Ratings

		VALUE	UNIT
V _(ESD)	Electrostatic discharge	Human-body model (HBM), per ANSI/ESDA/JEDEC JS-001 ⁽¹⁾	±2000
		Charged-device model (CDM), per JEDEC specification JESD22-C101 ⁽²⁾	±1000

- (1) JEDEC document JEP155 states that 500-V HBM allows safe manufacturing with a standard ESD control process.
- (2) JEDEC document JEP157 states that 250-V CDM allows safe manufacturing with a standard ESD control process.

7.3 Recommended Operating Conditions

over operating free-air temperature range (unless otherwise noted)

		MIN	NOM	MAX	UNIT
V _{DD}	Supply voltage	1.71		3.46	V
T _J	Junction temperature	-40		125	°C

7.4 Thermal Information

THERMAL METRIC ⁽¹⁾		LDC1101	UNIT
		DRC (VSON)	
		10 PINS	
R _{θJA}	Junction-to-ambient thermal resistance	44.2	°C/W
R _{θJC(top)}	Junction-to-case (top) thermal resistance	50.1	°C/W
R _{θJB}	Junction-to-board thermal resistance	19.6	°C/W
ψ _{JT}	Junction-to-top characterization parameter	0.7	°C/W
ψ _{JB}	Junction-to-board characterization parameter	19.8	°C/W
R _{θJC(bot)}	Junction-to-case (bottom) thermal resistance	4.4	°C/W

- (1) For more information about traditional and new thermal metrics, see the *Semiconductor and IC Package Thermal Metrics* application report, [SPRA953](#).

7.5 Electrical Characteristics

Over recommended operating conditions unless otherwise noted. $V_{DD} = 1.8\text{ V}$, $T_A = 25^\circ\text{C}$.

PARAMETER		TEST CONDITION ⁽¹⁾	MIN ⁽²⁾	TYP ⁽³⁾	MAX ⁽²⁾	UNIT
POWER						
V_{DD}	Supply voltage		1.71		3.46	V
I_{DD}	Supply current	START_CONFIG= 0x00, no sensor connected		1.9	2.7	mA
I_{DDS}	Supply current including sensor current	$f_{CLKIN} = 16\text{ MHz}$, $f_{SENSOR} = 2\text{ MHz}$, START_CONFIG = 0x00		3.2		mA
I_{DSSL}	Sleep mode supply current	START_CONFIG =0x01		135	180	μA
I_{SD}	Shutdown mode supply current			1.4	6.7	μA
SENSOR						
	R_p Measurement part-to-part variation	RESP_TIME= 6144, D_CONFIG=0x00, ALT_CONFIG=0x00, START_CONFIG = 0x00, $f_{SENSOR} = 2\text{ MHz}$		1%		
$I_{SENSORMAX}$	Sensor maximum current drive	RP_MIN = b111, START_CONFIG=0x00, D_CONFIG=0x00, ALT_CONFIG=0x00	0.598	0.6	0.602	mA
$I_{SENSORMIN}$	Sensor minimum current drive	RP_MAX = b000, RP_MAX_DIS=b0, START_CONFIG=0x00, D_CONFIG=0x00, ALT_CONFIG=0x00		4.7		μA
f_{SENSOR}	Sensor resonant frequency	Device settings and Sensor compliant as detailed in LDC1101 R_p Configuration	0.5		10	MHz
RP_{RES}	R_p Measurement resolution			16		bits
L_{RES}	Inductance sensing resolution – R_p+L Mode			16		bits
	Inductance sensing resolution – LHR Mode			24		bits
A_{OSC}	Sensor oscillation amplitude	INA – INB, START_CONFIG=0x00, D_CONFIG=0x00, ALT_CONFIG=0x00		1.2		V_{PP}
DETECTION						
t_{S_MIN}	Minimum response time (RP+L mode)	R_p+L Mode, RESP_TIME=b010		192 $\pm f_{SENSOR}$		s
t_{S_MAX}	Maximum response time (RP+L mode)	R_p+L Mode, RESP_TIME=b111		6144 $\pm f_{SENSOR}$		s
T_{S_MAX}	High Res L maximum measurement interval	LHR_REF_COUNT=0xFFFF, START_CONFIG=0x00		$(2^{20}+39)$ $\pm f_{CLKIN}$		s
SR_{MAXRP}	RP+L Mode maximum sample rate	$f_{CLKIN}=16\text{ MHz}$, $f_{SENSOR} = 10\text{ MHz}$, RESP_TIME=b010		156.25		kSPS
SR_{MAXL}	High Res L Mode Maximum Sample Rate	High Resolution L Mode, LHR_REF_COUNT=0x0002, $f_{CLKIN}=16\text{ MHz}$		183.8		kSPS
FREQUENCY REFERENCE						
f_{CLKIN}	Reference input frequency		1		16	MHz
DC_{fin}	Reference duty cycle		40%		60%	
V_{IH}	Input high voltage (Logic "1")			$0.8 \times V_{DD}$		V
V_{IL}	Input low voltage (Logic "0")			$0.2 \times V_{DD}$		V

- Register values are represented as either binary (b is the prefix to the digits), or hexadecimal (0x is the prefix to the digits). Decimal values have no prefix.
- Limits are ensured by testing, design, or statistical analysis at 25°C . Limits over the operating temperature range are ensured through correlation using statistical quality control (SQC) method.
- Typical values represent the most likely parametric norm as determined at the time of characterization. Actual typical values may vary over time and will also depend on the application and configuration. The typical values are not tested and are not guaranteed on shipped production material.

7.6 Digital Interface

PARAMETER		MIN	TYP	MAX	UNIT
VOLTAGE LEVELS		$0.8 \times V_{DD}$			V
V_{IH}	Input high voltage (Logic "1")			$0.2 \times V_{DD}$	V
V_{IL}	Input low voltage (Logic "0")		$V_{DD}-0.3$		V
V_{OH}	Output high voltage (Logic "1", $I_{SOURCE} = 400\ \mu\text{A}$)			0.3	V
V_{OL}	Output low voltage (Logic "0", $I_{SINK} = 400\ \mu\text{A}$)	-500		500	nA
I_{OHL}	Digital IO leakage current				

7.7 Timing Requirements

		MIN	TYP	MAX	UNIT
t_{START}	Start-up time from shutdown to sleep		0.8		ms
t_{WAKE}	Wake-up time (from completion of SPI to conversion start; does not include sensor settling time)		0.04		ms
INTERFACE TIMING REQUIREMENTS⁽¹⁾					
f_{SCLK}	Serial clock frequency			8	MHz
t_{WH}	SCLK pulse-width high	$0.4 / f_{SCLK}$			s
t_{WL}	SCLK pulse-width low	$0.4 / f_{SCLK}$			s
t_{SU}	SDI setup time	10			ns
t_H	SDI hold time	10			ns
t_{ODZ}	SDO driven-to-tristate time			25	ns
t_{OZD}	SDO tristate-to-driven time			25	ns
t_{OD}	SDO output delay time			20	ns
$t_{SU(CS)}$	CSB setup time	20			ns
$t_H(CS)$	CSB hold time	20			ns
t_{IAG}	CSB inter-access interval	100			ns
$t_{W(DRDY)}$	Data ready pulse width		$1/f_{SENSOR}$		ns

(1) Unless otherwise noted, all limits specified at $T_A = 25^\circ\text{C}$, $V_{DD} = 1.8\text{ V}$, 10 pF capacitive load in parallel with a 10 kΩ load on the SDO pin. Specified by design; not production tested.

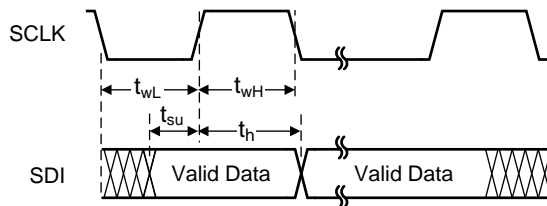

Figure 1. Write Timing Diagram

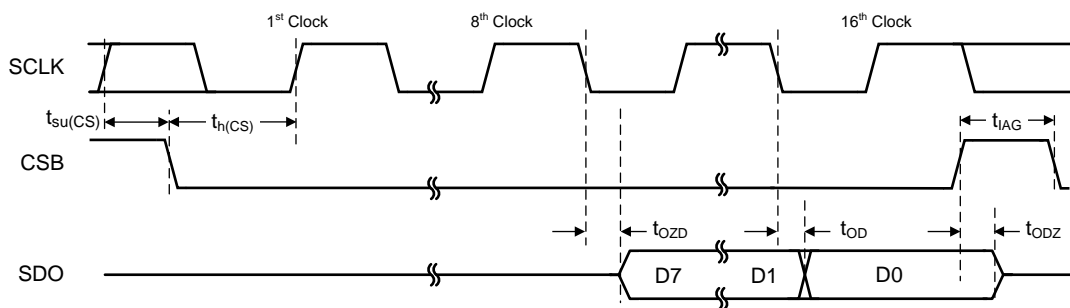
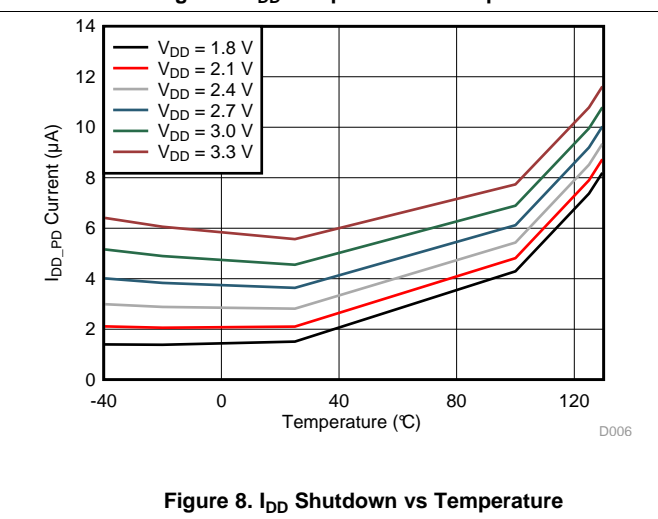
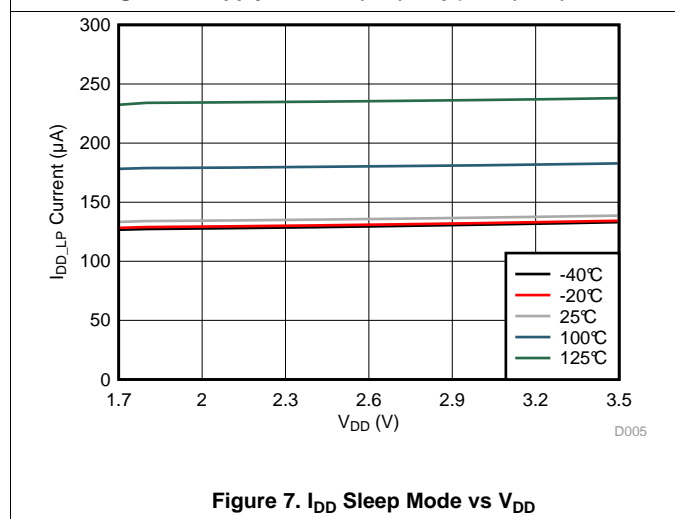
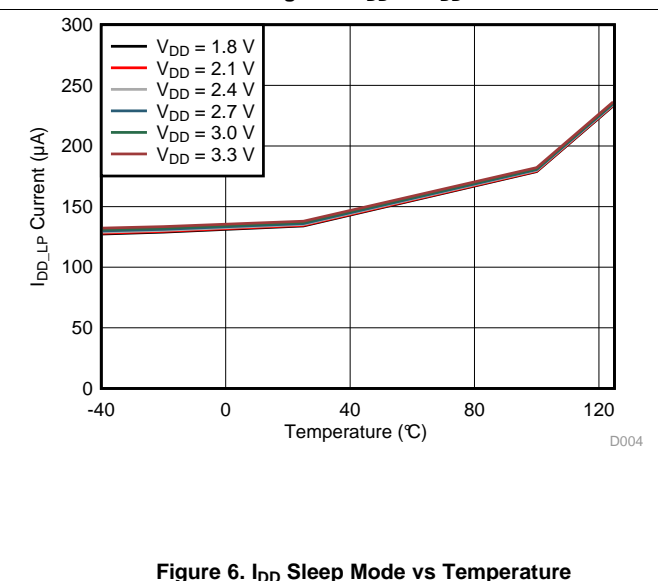
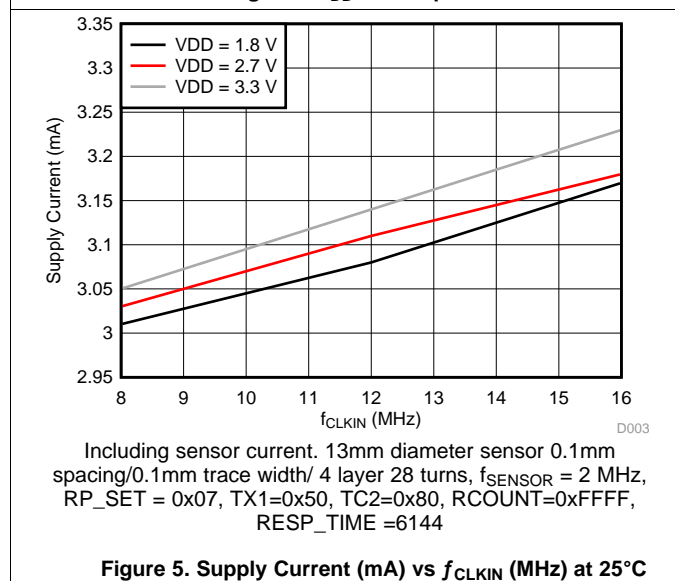
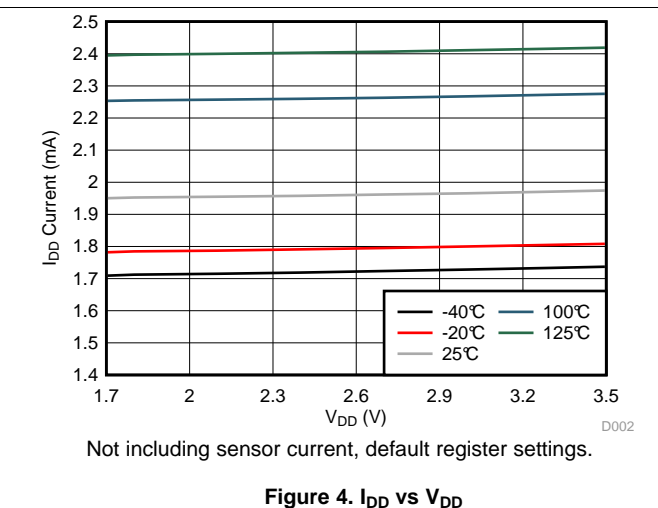
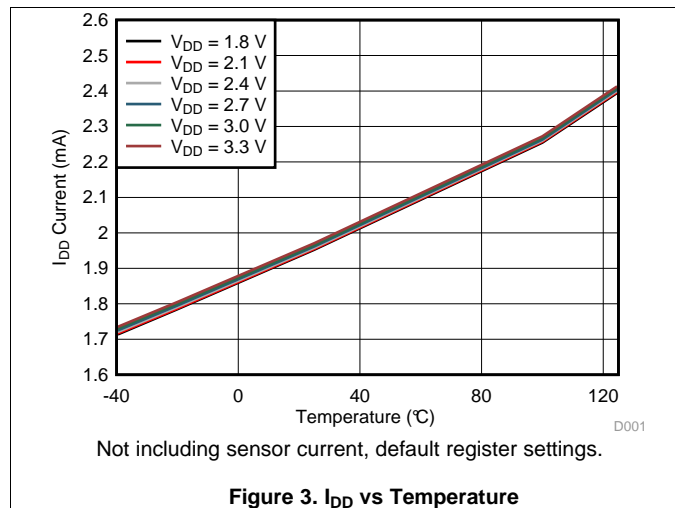
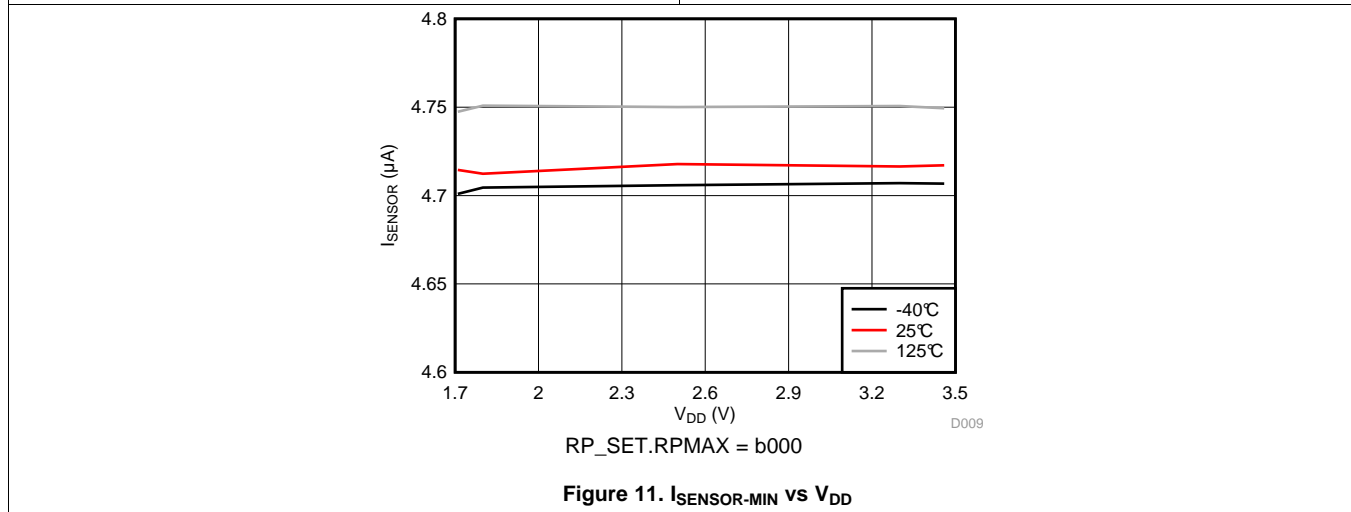
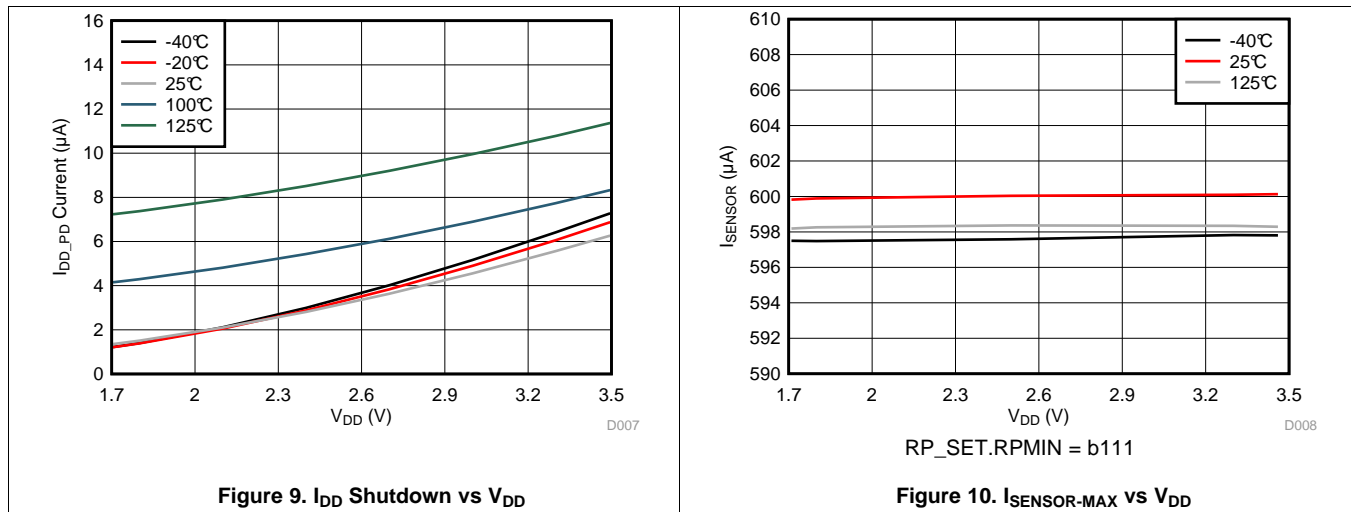

Figure 2. Read Timing Diagram

7.8 Typical Characteristics



Typical Characteristics (continued)



8 Detailed Description

8.1 Overview

The LDC1101 is an inductance-to-digital converter which can simultaneously measure the impedance and resonant frequency of an LC resonator. The high resolution measurement capability enables this device to be used to directly measure changes in physical systems, allowing the resonator to sense the proximity and movement of conductive materials.

The LDC1101 measures the impedance and resonant frequency by regulating the oscillation amplitude in a closed-loop configuration at a constant level, while monitoring the energy dissipated by the resonator. By monitoring the amount of power injected into the resonator, the LDC1101 can determine the equivalent parallel resistance of the resonator, R_p , which it returns as a digital value.

In addition, the LDC1101 device also measures the oscillation frequency of the LC circuit by comparing the sensor frequency to a provided reference frequency. The sensor frequency can then be used to determine the inductance of the LC circuit.

The threshold comparator block can compare the R_p+L conversion results versus a programmable threshold. With the threshold registers programmed and comparator enabled, the LDC1101 can provide a switch output, reported as a high/low level on the INTB/SDO pin.

The LDC1101 device supports a wide range of LC combinations with oscillation frequencies ranging from 500 kHz to 10 MHz and R_p ranging from 1.25 k Ω to 90 k Ω . The device is configured and conversion results retrieved through a simple 4-wire SPI. The power supply for the device can range from 1.8 V – 5% to 3.3 V + 5%. The only external components necessary for operation are a 15 nF capacitor for internal LDO bypassing and supply bypassing for VDD.

8.2 Functional Block Diagram

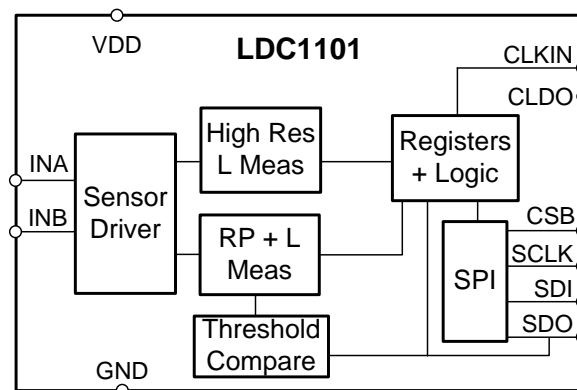

8.3 Feature Description

8.3.1 Sensor Driver

The LDC1101 can drive a sensor with a resonant frequency of 500 kHz to 10 MHz with an R_p in the range of 1.25 k Ω to 90 k Ω . The nominal sensor amplitude is 1.2 V. The sensor Q should be at least 10 for R_p measurements. The inductive sensor must be connected across the INA and INB pins. The resonant frequency of the sensor is set by:

$$f_{\text{SENSOR}} (\text{Hz}) = \frac{1}{2\pi\sqrt{L \times C}}$$

where

- L is the sensor inductance in Henrys, and
- C is the sensor parallel capacitance in Farads.

(1)

8.4 Device Functional Modes

8.4.1 Measurement Modes

The LDC1101 features two independent measurement subsystems to measure the impedance and resonant frequency of an attached sensor. The R_p+L subsystem can simultaneously measure the impedance and resonant frequency of an LC resonator, with up to 16 bits of resolution for each parameter. Refer to [\$R_p+L\$ Measurement Mode](#) for more information on the R_p+L measurement functionality.

The High Resolution L (LHR) subsystem measures the sensor resonant frequency with up to 24 bits of resolution. The effective resolution is a function of the sample rate and the reference frequency supplied on the CLKIN pin. Refer to [High Resolution L \(LHR\) Measurement Mode](#) for more information on the LHR measurement functionality.

Both measurement subsystems can convert simultaneously but at different sample intervals – the completion of an R_p+L conversion will be asynchronous to the completion of a LHR conversion.

Table 1. Comparison of Measurement Modes

	RP+L Mode	LHR Mode
R_p Measurement Resolution	16 bits	N/A
L Measurement Resolution	16 bits	24 bits
Sample Rate configuration	Varies with f_{SENSOR} , set by RESP_TIME	Fixed and set by RCOUNT field and f_{CLKIN}
Sample rate at highest resolution (SPS)	244	15.3
Maximum Sample Rate (kSPS)	156.25	183.9
L Resolution at Maximum Sample rate	6.7 bits	6.5 bits
Switch Output on SDO/INTB	Available for R_p or L output code	N/A

8.4.2 R_p+L Measurement Mode

In R_p+L mode, the LDC1101 will simultaneously measure the impedance and resonant frequency of the attached sensor. The device accomplishes this task by regulating the oscillation amplitude in a closed-loop configuration to a constant level, while monitoring the energy dissipated by the resonator. By monitoring the amount of power injected into the resonator, the LDC1101 device can determine the value of R_p . The device returns this value as a digital value which is proportional to R_p . In addition, the LDC1101 device can also measure the oscillation frequency of the LC circuit, by counting the number of cycles of a reference frequency. The measured sensor frequency can be used to determine the inductance of the LC circuit.

8.4.2.1 R_{pMIN} and R_{pMAX}

The variation of R_p in a given system is typically much smaller than maximum range of 1.25 k Ω to >90 k Ω supported by the LDC1101. To achieve better resolution for systems with smaller R_p ranges, the LDC1101 device offers a programmable R_p range.

The LDC1101 uses adjustable current drives to scale the R_p measurement range; by setting a tighter current range a higher accuracy R_p measurement can be performed. This functionality can be considered as a variable gain amplifier (VGA) front end to an ADC. The current ranges are configured in the R_{pMIN} and R_{pMAX} fields of register RP_SET (address 0x01). Refer to [LDC1101 \$R_p\$ Configuration](#) for instructions to optimize these settings.

8.4.2.2 Programmable Internal Time Constants

The LDC1101 utilizes internal programmable registers to configure time constants necessary for sensor oscillation. These internal time constants must be configured for R_p measurements. Refer to [Setting Internal Time Constant 1](#) and [Setting Internal Time Constant 2](#) for instructions on how to configure them for a given system.

8.4.2.3 R_p+L Mode Measurement Sample Rate

The LDC1101 provides an adjustable sample rate for the R_p+L conversion, where longer conversion times have higher resolution. Refer to [\$R_p+L\$ Sample Rate Configuration with RESP_TIME](#) for more details.

8.4.3 High Resolution L (LHR) Measurement Mode

The High Resolution L measurement (LHR) subsystem provides a high-resolution inductance (L) measurement of up to 24 bits. This L measurement can be configured to provide a higher resolution measurement than the measurement returned from the RP+L subsystem. The LHR subsystem also provides a constant conversion time interval, whereas the RP+L conversion interval is a function of the sensor frequency. The LHR measurement runs asynchronously with respect to the RP+L measurement.

8.4.4 Reference Count Setting

The LHR sample rate is set by the Reference Count (LHR_RCOUNT) setting (registers 0x30 and 0x31). The LHR conversion resolution is proportional to the programmed RCOUNT value. With the maximum supported 16 MHz CLKIN input, the LDC1101 conversion interval can be set from 8.6 μ s to 87.38 ms in 1 μ s increments. Note that longer conversion intervals produce more accurate LHR measurements. Refer to [LHR Sample Rate Configuration with RCOUNT](#) for more details.

8.4.5 L-Only Measurement Operation

The LDC1101 can disable the R_p measurement to perform a more stable L measurement. To enable this mode, set:

- ALT_CONFIG.LOPTIMAL(register 0x05-bit0) = 1
- D_CONFIG.DOK_REPORT (register 0x0C-bit0) = 1

When this mode is used, R_p measurement results are not valid.

8.4.6 Minimum Sensor Frequency and Watchdog Setting

The LDC1101 can report an error condition if the sensor oscillation stops. Refer to [MIN_FREQ and Watchdog Configuration](#) for information on the configuration of the watchdog.

8.4.7 Low Power Modes

When continuous LDC conversions are not required, the LDC1101 supports two reduced power modes. In Sleep mode, the LDC1101 retains register settings and can quickly enter active mode for conversions. In Shutdown mode, power consumption is significantly lower, although the device configuration is not retained. While in either low power mode, the LDC1101 will not perform conversions.

8.4.7.1 Shutdown Mode

Shutdown mode is the lowest power state for the LDC1101. Note that entering SD mode will reset all registers to their default state, and so the device must have its registers rewritten. To enter Shutdown, perform the following sequence:

1. Set ALT_CONFIG.SHUTDOWN_EN = 1 (register 0x05-bit[1]).
2. Stop toggling the CLKIN pin input and drive the CLKIN pin Low.
3. Set START_CONFIG.FUNC_MODE = b10 (register 0x0B:bits[1:0]). This register can be written while the LDC1101 is in active mode; on completion of the register write the LDC1101 will enter shutdown.

To exit Shutdown mode, resume toggling the clock input on the CLKIN pin; the LDC1101 will transition to Sleep mode with the default register values.

While in Shutdown mode, no conversions are performed. In addition, entering Shutdown mode will clear the status registers; if an error condition is present it will not be reported when the device exits Shutdown mode.

8.4.7.2 Sleep Mode

Sleep mode is entered by setting START_CONFIG.FUNC_MODE = b01 (register 0x0B:bits[1:0]). While in this mode, the register contents are maintained. To exit Sleep mode and start active conversions, set START_CONFIG.FUNC_MODE = b00. While in Sleep mode the SPI interface is functional so that register reads and writes can be performed.

On power-up or exiting Shutdown mode, the LDC1101 will be in Sleep mode.

Configuring the LDC1101 must be done while the device is in Sleep mode. If a setting on the LDC1101 needs to be changed, return the device to Sleep mode, change the appropriate register, and then return the LDC1101 to conversion mode. The registers related to INTB reporting can be changed while the LDC1101 is in active mode. Refer to [INTB Reporting on SDO](#) for more details.

8.4.8 Status Reporting

The LDC1101 provides 2 status registers, STATUS and LHR_STATUS, to report on the device and sensor condition.

Table 2. STATUS Fields

NAME	FIELD	FUNCTION
NO_SENSOR_OSC	7	When the resonance impedance of the sensor, R_p , drops below the programmed R_{p_MIN} , the sensor oscillation may stop. This condition is reported by STATUS:NO_SENSOR_OSC (register 0x20-bit7). This condition could occur when a target comes too close to the sensor or if RP_SET:RP_MIN (register 0x01-bits[2:0]) is set too high.
DRDYB	6	RP+L Data Ready - reports completion of RP+L conversion results
RP_HIN	5	RP+L threshold – refer to Comparator Functionality for details
RP_HI_LON	4	
L_HIN	3	
L_HI_LON	2	
POR_READ	0	Device in Power-On Reset – device should only be configured when POR_READ = 0.

The LHR_STATUS register (register 0x3B) reports on LHR functionality.

8.4.9 Switch Functionality and INTB Reporting

The SDO pin can generate INTB, a signal which corresponds to device status. INTB can report conversion completion or provide a comparator output, in which the LDC conversion results are internally compared to programmable thresholds. Refer to [INTB Reporting on SDO](#) for details.

8.5 Programming

8.5.1 SPI Programming

The LDC1101 uses SPI to configure the internal registers. It is necessary to configure the LDC1101 while in Sleep mode. If a setting on the LDC1101 needs to be changed, return the device to Sleep mode, change the appropriate register, and then return the LDC1101 to conversion mode. CSB must go low before accessing first address. If the number of SCLK pulses is less than 16, a register write command will not change the contents of the addressed register.

Programming (continued)

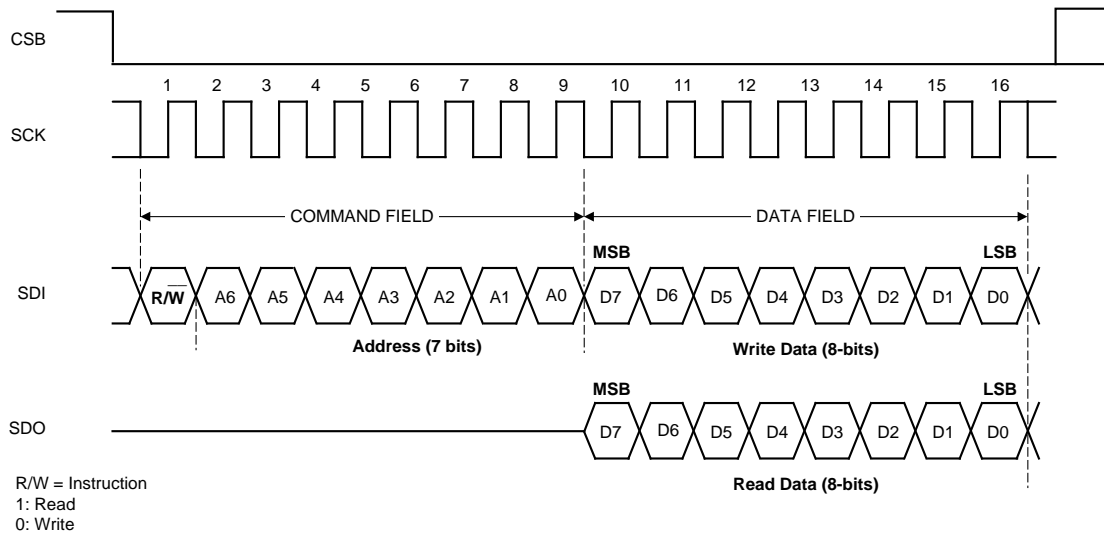

Figure 12. SPI Transaction Format

The LDC1101 supports an extended SPI transaction, in which CSB is held low and sequential register addresses can be written or read. After the first register transaction, each additional 8 SCLK pulses will address the next register, reading or writing based on the initial R/W flag in the initial command. A register write command will take effect on the 8th clock pulse. Two or more registers can be programmed using this method. The register address must not increment above 0x3F.

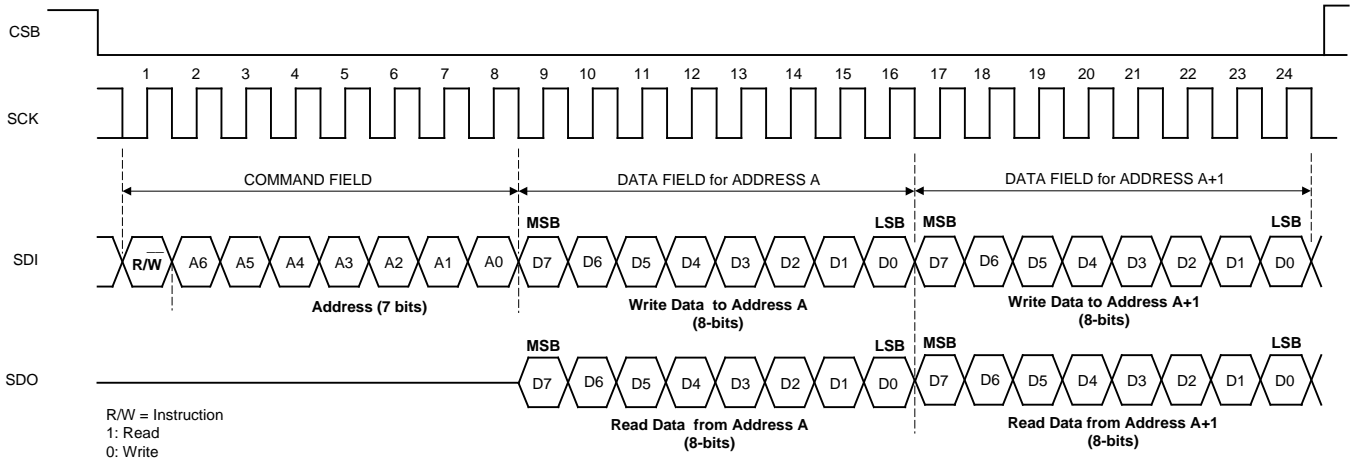

Figure 13. Extended SPI Transaction

8.6 Register Maps

Table 3. Register List

ADDRESS	NAME	DEFAULT VALUE	DESCRIPTION
0x01	RP_SET	0x07	Configure R _P Measurement Dynamic Range
0x02	TC1	0x90	Configure Internal Time Constant 1
0x03	TC2	0xA0	Configure Internal Time Constant 2
0x04	DIG_CONFIG	0x03	Configure RP+L conversion interval
0x05	ALT_CONFIG	0x00	Configure additional device settings
0x06	RP_THRESH_H_LSB	0x00	RP_THRESHOLD High Setting – bits 7:0. This register can be modified while the LDC1101 is in active mode.
0x07	RP_THRESH_H_MSB	0x00	RP_THRESHOLD High Setting – bits 15:8. This register can be modified while the LDC1101 is in active mode.
0x08	RP_THRESH_L_LSB	0x00	RP_THRESHOLD Low Setting – bits 7:0. This register can be modified while the LDC1101 is in active mode.
0x09	RP_THRESH_L_MSB	0x00	RP_THRESHOLD Low Setting – bits 15:8. This register can be modified while the LDC1101 is in active mode.
0x0A	INTB_MODE	0x00	Configure INTB reporting on SDO pin. This register can be modified while the LDC1101 is in active mode.
0x0B	START_CONFIG	0x01	Configure Power State
0x0C	D_CONF	0x00	Sensor Amplitude Control Requirement
0x16	L_THRESH_HI_LSB	0x00	L_THRESHOLD High Setting – bits 7:0. This register can be modified while the LDC1101 is in active mode.
0x17	L_THRESH_HI_MSB	0x00	L_THRESHOLD High Setting – bits 15:8. This register can be modified while the LDC1101 is in active mode.
0x18	L_THRESH_LO_LSB	0x00	L_THRESHOLD Low Setting – bits 7:0. This register can be modified while the LDC1101 is in active mode.
0x19	L_THRESH_LO_MSB	0x00	L_THRESHOLD Low Setting – bits 15:8. This register can be modified while the LDC1101 is in active mode.
0x20	STATUS	0x00	Report RP+L measurement status
0x21	RP_DATA_LSB	0x00	R _P Conversion Result Data Output - bits 7:0
0x22	RP_DATA_MSB	0x00	R _P Conversion Result Data Output - bits 15:8
0x23	L_DATA_LSB	0x00	L Conversion Result Data Output - bits 7:0
0x24	L_DATA_MSB	0x00	L Conversion Result Data Output - bits 15:8
0x30	LHR_RCOUNT_LSB	0x00	High Resolution L Reference Count – bits 7:0
0x31	LHR_RCOUNT_MSB	0x00	High Resolution L Reference Count – bits 15:8
0x32	LHR_OFFSET_LSB	0x00	High Resolution L Offset – bits 7:0
0x33	LHR_OFFSET_MSB	0x00	High Resolution L Offset – bits 15:8
0x34	LHR_CONFIG	0x00	High Resolution L Configuration
0x38	LHR_DATA_LSB	0x00	High Resolution L Conversion Result Data output - bits 7:0
0x39	LHR_DATA_MID	0x00	High Resolution L Conversion Result Data output - bits 15:8
0x3A	LHR_DATA_MSB	0x00	High Resolution L Conversion Result Data output - bits 23:16
0x3B	LHR_STATUS	0x00	High Resolution L Measurement Status
0x3E	RID	0x02	Device RID value
0x3F	CHIP_ID	0xD4	Device ID value

8.6.1 Individual Register Listings

Fields indicated with Reserved must be written only with indicated values. Improper device operation may occur otherwise. The R/W column indicates the Read-Write status of the corresponding field. A 'R/W' entry indicates read and write capability, a 'R' indicates read-only, and a 'W' indicates write-only.

8.6.2 Register RP_SET (address = 0x01) [reset = 0x07]

Figure 14. Register RP_SET

7	6	5	4	3	2	1	0
RPMAX_DIS	RP_MAX		RESERVED		RP_MIN		
R/W	R/W		R/W		R/W		

LEGEND: R/W = Read/Write; R = Read only; -n = value after reset

Table 4. Register RP_SET Field Descriptions

Bit	Field	Type	Reset	Description
7	RPMAX_DIS	R/W		RP_MAX Disable This setting improves the R_P measurement accuracy for very high Q coils by driving 0A as the $R_{P_{MAX}}$ current drive. b0: Programmed RP_MAX is driven (default value) b1: RP_MAX current is ignored; current drive is off.
6:4	RP_MAX	R/W		RP_MAX Setting Set the maximum input dynamic range for the sensor R_P measurement. The programmed RP_MIN setting must not exceed the programmed RP_MAX setting. b000: RPMAX = 96 k Ω (default value) b001: RPMAX = 48 k Ω b010: RPMAX = 24 k Ω b011: RPMAX = 12 k Ω b100: RPMAX = 6 k Ω b101: RPMAX = 3 k Ω b110: RPMAX = 1.5 k Ω b111: RPMAX = 0.75 k Ω
3	RESERVED	R/W		Reserved. Set to 0
2:0	RP_MIN	R/W		RP_MIN Setting Set the minimum input dynamic range for the sensor R_P measurement. The programmed RP_MIN setting must not exceed the programmed RP_MAX setting. b000: RPMIN = 96 k Ω b001: RPMIN = 48 k Ω b010: RPMIN = 24 k Ω b011: RPMIN = 12 k Ω b100: RPMIN = 6 k Ω b101: RPMIN = 3 k Ω b110: RPMIN = 1.5 k Ω b111: RPMIN = 0.75 k Ω (default value)

8.6.3 Register TC1 (address = 0x02) [reset = 0x90]
Figure 15. Register TC1

7	6	5	4	3	2	1	0
C1		RESERVED			R1		
R/W		R/W		R/W			

LEGEND: R/W = Read/Write; R = Read only; -n = value after reset

Table 5. Register TC1 Field Descriptions

Bit	Field	Type	Reset	Description
7:6	C1	R/W		Internal Time Constant 1 Capacitance This sets the capacitive component used to configure internal time constant 1. Refer to Setting Internal Time Constant 1 for more details. b00: C1 = 0.75 pF b01: C1 = 1.5 pF b10: C1 = 3.0 pF (default value) b11: C1 = 6.0 pF
5	RESERVED	R/W		Reserved. Set to 0
4:0	R1	R/W		Internal Time Constant 1 Resistance This sets the resistive component used to configure internal time constant 1. Refer to Setting Internal Time Constant 1 for configuration details. $R1(\Omega) = -12.77 \text{ k}\Omega \times R1 + 417 \text{ k}\Omega$ Valid Values: [b0'0000:b1'1111] b0'0000: $R_1 = 417 \text{ k}\Omega$ b1'0000: $R_1 = 212.7 \text{ k}\Omega$ (default value) b1'1111: $R_1 = 21.1 \text{ k}\Omega$

8.6.4 Register TC2 (address = 0x03) [reset = 0xA0]
Figure 16. Register TC2

7	6	5	4	3	2	1	0
C2				R2			
R/W		R/W					

LEGEND: R/W = Read/Write; R = Read only; -n = value after reset

Table 6. Register TC2 Field Descriptions

Bit	Field	Type	Reset	Description
7:6	C2	R/W		Internal Time Constant 2 Capacitance This sets the capacitive component used to configure internal time constant 2. Refer to Setting Internal Time Constant 2 for configuration details. b00: C2 = 3 pF b01: C2 = 6 pF b10: C2 = 12 pF (default value) b11: C2 = 24 pF
5:0	R2	R/W		Internal Time Constant 2 Resistance This sets the resistive component used to configure internal time constant 2. Refer to Setting Internal Time Constant 2 for details. $R2(\Omega) = -12.77 \text{ k}\Omega \times R2 + 835 \text{ k}\Omega$ Valid Values: [b00'0000:b11'1111] b00'0000: $R_2 = 835 \text{ k}\Omega$ b10'0000: $R_2 = 426.4 \text{ k}\Omega$ (default value) b11'1111: $R_2 = 30.5 \text{ k}\Omega$

8.6.5 Register DIG_CONF (address = 0x04) [reset = 0x03]

Figure 17. Register DIG_CONF

7	6	5	4	3	2	1	0
MIN_FREQ				RESERVED	RESP_TIME		
R/W				R/W			

LEGEND: R/W = Read/Write; R = Read only; -n = value after reset

Table 7. Register DIG_CONF Field Descriptions

Bit	Field	Type	Reset	Description
7:4	MIN_FREQ	R/W		Sensor Minimum Frequency Configure this register based on the lowest possible sensor frequency. This is typically when the target is providing minimum interaction with the sensor, although with some steel and ferrite targets, the minimum sensor frequency occurs with maximum target interaction. This setting should include any additional effects which reduce the sensor frequency, including temperature shifts and sensor capacitor variation. $MIN_FREQ = 16 - (8 \text{ MHz} \div f_{\text{SENSORMIN}})$ b0000: $f_{\text{SENSORMIN}} = 500 \text{ kHz}$ (default value) b1111: $f_{\text{SENSORMIN}} = 8 \text{ MHz}$
3	RESERVED	R/W		Reserved. Set to 0
2:0	RESP_TIME	R/W		Measurement Response Time Setting Sets the Response Time, which is the number of sensor periods used per conversion. This setting applies to the R_P and Standard Resolution L measurement, but not the High Resolution L measurement. This corresponds to the actual conversion time by: $\text{Conversion Time (s)} = \frac{\text{Response Time}}{3 \times f_{\text{SENSOR}}}$ b000: Reserved (do not use) b001: Reserved (do not use) b010: Response Time = 192 b011: Response Time = 384 (default value) b100: Response Time = 768 b101: Response Time = 1536 b110: Response Time = 3072 b111: Response Time = 6144

8.6.6 Register ALT_CONFIG (address = 0x05) [reset = 0x00]

Figure 18. Register ALT_CONFIG

7	6	5	4	3	2	1	0
RESERVED						SHUTDOWN_EN	LOPTIMAL
R/W						R/W	R/W

LEGEND: R/W = Read/Write; R = Read only; -n = value after reset

Table 8. Register ALT_CONFIG Field Descriptions

Bit	Field	Type	Reset	Description
7:2	RESERVED	R/W		Reserved. Set to b00'0000.
1	SHUTDOWN_EN	R/W		Shutdown Enable Enables shutdown mode of operation. If SHUTDOWN_EN is not set to 1, then SHUTDOWN (Address 0x0B:[1]) will not have any effect. b0: Shutdown not enabled. (default value) b1: Shutdown functionality enabled.

Table 8. Register ALT_CONFIG Field Descriptions (continued)

Bit	Field	Type	Reset	Description
0	LOPTIMAL	R/W		Optimize for L Measurements Optimize sensor drive signal for L measurements (for both High-Res L and L measurement). When LOPTIMAL is enabled, R _p measurements will not be completed. It is also necessary to set DOK_REPORT=1 when this mode is enabled. b0: L optimal disabled; both RP+L/LHR measurements (default value) b1: Only perform LHR and/or L-only measurements. R _p measurements are invalid.

8.6.7 Register RP_THRESH_HI_LSB (address = 0x06) [reset = 0x00]

This register can be modified while the LDC1101 is in active mode.

Figure 19. Register RP_THRESH_HI_LSB

7	6	5	4	3	2	1	0
RP_THRESH_HI_LSB							
R/W							

LEGEND: R/W = Read/Write; R = Read only; -n = value after reset

Table 9. Register RP_THRESH_HI_LSB Field Descriptions

Bit	Field	Type	Reset	Description
7:0	RP_THRESH_HI_LSB	R/W		R_p High Threshold LSB Setting Combine with value in Register RP_THRESH_HI_MSB (Address 0x07) to set the upper R _p conversion threshold: $RP_THRESH_HI = RP_THRESH_HI[15:8] \times 256 + RP_THRESH_HI[7:0]$ If RP_DATA conversion result is greater than the RP_THRESH_HI, RP_TH_I will be asserted. Note that RP_THRESH_HI_LSB is buffered and will not change the device configuration until a write to RP_TRESH_HI_MSB is performed. Note that both registers 0x06 and 0x07 must be written to change the value of RP_THRESH_HI. 0x00: default value

8.6.8 Register RP_THRESH_HI_MSB (address = 0x07) [reset = 0x00]

This register can be modified while the LDC1101 is in active mode.

Figure 20. Register RP_THRESH_HI_MSB

7	6	5	4	3	2	1	0
RP_THRESH_HI_MSB							
R/W							

LEGEND: R/W = Read/Write; R = Read only; -n = value after reset

Table 10. Register RP_THRESH_HI_MSB Field Descriptions

Bit	Field	Type	Reset	Description
7:0	RP_THRESH_HI_MSB	R/W		R_p High Threshold MSB Setting Combine with value in Register RP_THRESH_HI_LSB (Address 0x06) to set the upper R _p conversion threshold. 0x00: default value

8.6.9 Register RP_THRESH_LO_LSB (address = 0x08) [reset = 0x00]

This register can be modified while the LDC1101 is in active mode.

Figure 21. Register RP_THRESH_LO_LSB

7	6	5	4	3	2	1	0
RP_THRESH_LO_LSB							
R/W							

LEGEND: R/W = Read/Write; R = Read only; -n = value after reset

Table 11. Register RP_THRESH_LO_LSB Field Descriptions

Bit	Field	Type	Reset	Description
7:0	RP_THRESH_LO[7:0]	R/W		<p>R_P Low Threshold LSB Setting</p> <p>Combine with value in Register RP_THRESH_LO_MSB (Address 0x09) to set the lower R_P conversion threshold:</p> $RP_THRESH_LO = RP_THRESH_LO[15:8] \times 256 + RP_THRESH_LO[7:0]$ <p>If RP_DATA conversion result is less than the RP_THRESH_LO, RP_HI_LON will be asserted. Note that RP_THRESH_LO_LSB is buffered and will not change the device configuration until a write to RP_THRESH_LO_MSB is performed.</p> <p>Note that both registers 0x08 and 0x09 must be written to change the value of RP_THRESH_LO.</p> <p>0x00: default value</p>

8.6.10 Register RP_THRESH_LO_MSB (address = 0x09) [reset = 0x00]

This register can be modified while the LDC1101 is in active mode

Figure 22. Register RP_THRESH_LO_MSB

7	6	5	4	3	2	1	0
RP_THRESH_LO_MSB							
R/W							

LEGEND: R/W = Read/Write; R = Read only; -n = value after reset

Table 12. Register RP_THRESH_LO_MSB Field Descriptions

Bit	Field	Type	Reset	Description
7:0	RP_THRESH_LO_MSB[15:8]	R/W		<p>R_P Low Threshold MSB Setting</p> <p>Combine with value in Register RP_THRESH_LO_LSB (Address 0x08) to set the lower R_P conversion threshold.</p> <p>0x00: default value</p>

8.6.11 Register INTB_MODE (address = 0x0A) [reset = 0x00]

This register can be modified while the LDC1101 is in active mode.

Figure 23. Register INTB_MODE

7	6	5	4	3	2	1	0
INTB2SDO	RESERVED	INTB_FUNC					
R/W	R/W	R/W					

LEGEND: R/W = Read/Write; R = Read only; -n = value after reset

Table 13. NAME Field Descriptions

Bit	Field	Type	Reset	Description
7	INTB2SDO	R/W		INTB Output on SDO Output INTB signal on SDO pin. b0: do not report DRDY on SDO pin (default value) b1: report DRDY on SDO pin
6	RESERVED	R/W		Reserved. Set to 0
5:0	INTB_FUNC	R/W		Select INTB signal reporting. INTB2SDO must be set to 1 for the selected signal to appear on the SDO pin. Refer to INTB Reporting on SDO for configuration details. b10'0000: Report LHR Data Ready b01'0000: Compare L conversion to L Thresholds (hysteresis) b00'1000: Compare L conversion to L High Threshold (latching) b00'0100: Report RP+L Data Ready b00'0010: Compare R _P conversion to R _P Thresholds (hysteresis) b00'0001: Compare R _P conversion to R _P High Threshold (latching) b00'0000: no output (default value) All other values: Reserved

8.6.12 9.Register START_CONFIG (address = 0x0B) [reset = 0x01]

This register can be modified while the LDC1101 is in active mode.

Figure 24. Register START_CONFIG

7	6	5	4	3	2	1	0
RESERVED						FUNC_MODE	
R/W						R/W	

LEGEND: R/W = Read/Write; R = Read only; -n = value after reset

Table 14. Register START_CONFIG Field Descriptions

Bit	Field	Type	Reset	Description
7:2	RESERVED	R/W		Reserved. Set to b00'0000
1:0	FUNC_MODE	R/W		Functional Mode Configure functional mode of device. In active mode, the device performs conversions. When in Sleep mode, the LDC1101 is in a reduced power mode; the device should be configured in this mode. Shutdown mode is a minimal current mode in which the device configuration is not retained. Note that SHUTDOWN_EN must be set to 1 prior to setting FUNC_MODE to b10. b00: Active conversion mode b01: Sleep mode (default value) b10: Set device to shutdown mode b11: Reserved

8.6.13 Register D_CONFIG (address = 0x0C) [reset = 0x00]
Figure 25. Register D_CONFIG

7	6	5	4	3	2	1	0
RESERVED						DOK_REPORT	
R/W						R/W	

LEGEND: R/W = Read/Write; R = Read only; -n = value after reset

Table 15. Register D_CONFIG Field Descriptions

Bit	Field	Type	Reset	Description
7:1	RESERVED	R/W		Reserved. Set to b000'0000.
0	DOK_REPORT	R/W		Sensor Amplitude Control Continue to convert even if sensor amplitude is not regulated. b0: Require amplitude regulation for conversion (default value) b1: LDC will continue to convert even if sensor amplitude is unable to maintain regulation.

8.6.14 Register L_THRESH_HI_LSB (address = 0x16) [reset = 0x00]

This register can be modified while the LDC1101 is in active mode.

Figure 26. Register L_THRESH_HI_LSB

7	6	5	4	3	2	1	0
L_THRESH_HI[7:0]							
R/W							

LEGEND: R/W = Read/Write; R = Read only; -n = value after reset

Table 16. Register L_THRESH_HI_LSB Field Descriptions

Bit	Field	Type	Reset	Description
7:0	L_THRESH_HI[7:0]	R/W		L High Threshold LSB Setting Combine with value in Register L_THRESH_HI_MSB (Address 0x17) to set the upper L conversion threshold: $L_{ThreshHI} = L_THRESH_HI[15:8] \times 256 + L_THRESH_HI[7:0]$ If L_DATA conversion result is greater than the L_THRESH_HI, L_HIN will be asserted. Note that L_THRESH_HI_LSB is buffered and will not change the device configuration until a write to L_TRESH_HI_MSB. 0x00: default value

8.6.15 Register L_THRESH_HI_MSB (address = 0x17) [reset = 0x00]

This register can be modified while the LDC1101 is in active mode.

Figure 27. Register L_THRESH_HI_MSB

7	6	5	4	3	2	1	0
L_THRESH_HI[15:8]							
R/W							

LEGEND: R/W = Read/Write; R = Read only; -n = value after reset

Table 17. Register L_THRESH_HI_MSB Field Descriptions

Bit	Field	Type	Reset	Description
7:0	L_THRESH_HI[15:8]	R/W		L High Threshold MSB Setting Combine with value in Register L_THRESH_HI_LSB (Address 0x16) to set the upper L conversion threshold. 0x00: default value

8.6.16 Register L_THRESH_LO_LSB (address = 0x18) [reset = 0x00]

This register can be modified while the LDC1101 is in active mode.

Figure 28. Register L_THRESH_LO_LSB

7	6	5	4	3	2	1	0
L_THRESH_L[7:0]							
R/W							

LEGEND: R/W = Read/Write; R = Read only; -n = value after reset

Table 18. Register L_THRESH_LO_LSB Field Descriptions

Bit	Field	Type	Reset	Description
7:0	L_THRESH_LO[7:0]	R/W		L Low Threshold LSB Setting Combine with value in Register L_THRESH_LO_MSB (Address 0x19) to set the lower L conversion threshold: $L_{ThreshLO} = L_THRESH_LO[15:8] \times 256 + L_THRESH_LO[7:0]$ If L_DATA conversion result is less than the L_THRESH_LO, L_HI_LON will be asserted. Note that L_THRESH_LO_LSB is buffered and will not change the device configuration until a write to L_TRESH_LO_MSB. 0x00: default value

8.6.17 Register L_THRESH_LO_MSB (address = 0x19) [reset = 0x00]

This register can be modified while the LDC1101 is in active mode.

Figure 29. L_THRESH_LO_MSB

7	6	5	4	3	2	1	0
L_THRESH_L[15:8]							
R/W							

LEGEND: R/W = Read/Write; R = Read only; -n = value after reset

Table 19. L_THRESH_LO_MSB Field Descriptions

Bit	Field	Type	Reset	Description
7:0	L_THRESH_LO[15:8]	R/W		L Low Threshold MSB Setting Combine with value in Register L_THRESH_LO_LSB (Address 0x18) to set the lower L conversion threshold. 0x00: default value

8.6.18 Register STATUS (address = 0x020) [reset = 0x00]
Figure 30. Register STATUS

7	6	5	4	3	2	1	0
NO_SENSOR_OSC	DRDYB	RP_HIN	RP_HI_LON	L_HIN	L_HI_LON	RESERVED	POR_READ
R	R	R	R	R	R	R	R

LEGEND: R/W = Read/Write; R = Read only; -n = value after reset

Table 20. Register STATUS Field Descriptions

Bit	Field	Type	Reset	Description
7	NO_SENSOR_OSC	R		Sensor Oscillation Not Present Error Indicates that the sensor has stopped oscillating. This error may also be produced if the MIN_FREQ is set to too high a value. b0: Error condition has not occurred b1: LDC1101 has not detected the sensor oscillation.
6	DRDYB	R		RP+L Data Ready b0: New RP+L conversion data is available. b1: No new conversion data is available.

Table 20. Register STATUS Field Descriptions (continued)

Bit	Field	Type	Reset	Description
5	RP_HIN	R		RP_DATA High Threshold Comparator Note this field will latch a low value. To clear, write 0x00 to register 0x0A. INTB_FUNC (register 0x0A:bits[5:0]) must be set to b00'0001 for this flag to be reported. b0: RP_DATA measurement has exceeded RP_THRESH_HI b1: RP_DATA measurement has not exceeded RP_THRESH_HI
4	RP_HI_LON	R		RP_DATA Hysteresis Comparator b0: RP_DATA measurement has gone above RP_THRESH_LO. b1: RP_DATA measurement has gone below RP_THRESH_HI.
3	L_HIN	R		L_DATA High Threshold Comparator Note this field will latch a low value. To clear, write 0x00 to register 0x0A. INTB_FUNC (register 0x0A:bits[5:0]) must be set to b00'1000 for this flag to be reported. b0: L_DATA measurement has exceeded L_THRESH_HI b1: L_DATA measurement has not exceeded L_THRESH_HI
2	L_HI_LON	R		L_DATA Hysteresis Comparator b0: L_DATA measurement has gone above L_THRESH_LO. b1: L_DATA measurement has gone below L_THRESH_HI.
1	RESERVED	R		No Function 0: default value
0	POR_READ	R		Device in Power-On-Reset Indicates the device is in process of resetting. Note that the device cannot accept any configuration changes until reset is complete. Wait until POR_READ = 0 before changing any device configuration. b0: Device is not in reset. b1: Device is currently in reset; wait until POR_READ = 0.

8.6.19 Register RP_DATA_LSB (address = 0x21) [reset = 0x00]
Figure 31. Register RP_DATA_LSB

7	6	5	4	3	2	1	0
RP_DATA[7:0]							
R							

LEGEND: R/W = Read/Write; R = Read only; -n = value after reset

Table 21. Register RP_DATA_LSB Field Descriptions

Bit	Field	Type	Reset	Description
7:0	RP_DATA[7:0]	R		RP-Measurement Conversion Result Combine with values in Register RP_DATA_MSB (Address 0x22) to determine R _p conversion result: $RP_DATA = RP_DATA[15:8] \times 256 + RP_DATA[7:0]$ NOTE: RP_DATA_LSB (Address 0x21) must be read prior to reading the RP_DATA_MSB (Address 0x22) register to properly retrieve conversion results.

8.6.20 Register RP_DATA_MSB (address = 0x22) [reset = 0x00]
Figure 32. Register RP_DATA_MSB

7	6	5	4	3	2	1	0
RP_DATA[15:8]							
R							

LEGEND: R/W = Read/Write; R = Read only; -n = value after reset

Table 22. Register RP_DATA_MSB Field Descriptions

Bit	Field	Type	Reset	Description
7:0	RP_DATA[15:8]	R		RP-Measurement Conversion Result Combine with values in Register RP_DATA_LSB (Address 0x21) to determine R _P conversion result: NOTE: RP_DATA_LSB (Address 0x21) must be read prior to reading this register to properly retrieve conversion results.

8.6.21 Register L_DATA_LSB (address = 0x23) [reset = 0x00]

Figure 33. Register L_DATA_LSB

7	6	5	4	3	2	1	0
L_DATA[7:0]							
R							

LEGEND: R/W = Read/Write; R = Read only; -n = value after reset

Table 23. Register L_DATA_LSB Field Descriptions

Bit	Field	Type	Reset	Description
7:0	L_DATA[7:0]	R		L-Measurement Conversion Result Combine with values in Register L_DATA_MSB (Address 0x24) to determine L conversion result: $L_DATA = L_DATA[15:8] \times 256 + L_DATA[7:0]$ $f_{SENSOR} = (f_{CLKIN} \times RESP_TIME) / (3 \times L_DATA)$ NOTE: RP_DATA_LSB (Address 0x21) must be read prior to reading this register to properly retrieve conversion results.

8.6.22 Register L_DATA_MSB (address = 0x24) [reset = 0x00]

Figure 34. Register L_DATA_MSB

7	6	5	4	3	2	1	0
L_DATA[15:8]							
R							

LEGEND: R/W = Read/Write; R = Read only; -n = value after reset

Table 24. Register L_DATA_MSB Field Descriptions

Bit	Field	Type	Reset	Description
7:0	L_DATA[15:8]	R		L-Measurement Conversion Result Combine with values in Register L_DATA_LSB (Address 0x23) to determine L conversion result: NOTE: RP_DATA_LSB (Address 0x21) must be read prior to reading this register to properly retrieve conversion results.

8.6.23 Register LHR_RCOUNT_LSB (address = 0x30) [reset = 0x00]

Figure 35. Register LHR_RCOUNT_LSB

7	6	5	4	3	2	1	0
RCOUNT[7:0]							
R/W							

LEGEND: R/W = Read/Write; R = Read only; -n = value after reset

Table 25. Register LHR_RCOUNT_LSB Field Descriptions

Bit	Field	Type	Reset	Description
7:0	RCOUNT[7:0]	R		High Resolution L-Measurement Reference Count Setting Combine with value in Register LHR_RCOUNT_MSB (Address 0x31) to set the measurement time for High Resolution L Measurements. 0x00: default value

8.6.24 Register LHR_RCOUNT_MSB (address = 0x31) [reset = 0x00]
Figure 36. Register LHR_RCOUNT_MSB

7	6	5	4	3	2	1	0
RCOUNT[15:8]							
R/W							

LEGEND: R/W = Read/Write; R = Read only; -n = value after reset

Table 26. Register LHR_RCOUNT_MSB Field Descriptions

Bit	Field	Type	Reset	Description
7:0	RCOUNT[15:8]			High Resolution L-Measurement Reference Count Setting Combine with value in Register LHR_RCOUNT_LSB (Address 0x30) to set the measurement time for High Resolution L Measurements. Higher values for LHR_RCOUNT have a higher effective measurement resolution but a lower sample rate. Refer to LHR Sample Rate Configuration with RCOUNT for more details. Measurement Time (t_{CONV})= (RCOUNT[15:0] × 16 + 55)/ f_{CLKIN} RCOUNT = RCOUNT [15:8]×256 + RCOUNT [7:0] Valid range: 2 ≤ RCOUNT[15:8] ≤ 65535 0x00: default value

8.6.25 Register LHR_OFFSET_LSB (address = 0x32) [reset = 0x00]
Figure 37. Register LHR_OFFSET_LSB

7	6	5	4	3	2	1	0
LHR_OFFSET[7:0]							
R/W							

LEGEND: R/W = Read/Write; R = Read only; -n = value after reset

Table 27. Register LHR_OFFSET_LSB Field Descriptions

Bit	Field	Type	Reset	Description
7:0	LHR_OFFSET[7:0]	R/W		High Resolution L-Measurement Offset Setting Combine with value in Register LHR_OFFSET_MSB (Address 0x33) to set the offset value applied to High Resolution L Measurements. 0x00: default value

8.6.26 Register LHR_OFFSET_MSB (address = 0x33) [reset = 0x00]
Figure 38. Register LHR_OFFSET_MSB

7	6	5	4	3	2	1	0
LHR_OFFSET[15:8]							
R/W							

LEGEND: R/W = Read/Write; R = Read only; -n = value after reset

Table 28. Register LHR_OFFSET_MSB Field Descriptions

Bit	Field	Type	Reset	Description
7:0	LHR_OFFSET[15:8]	R/W		High Resolution L-Measurement Offset Setting Combine with value in Register LHR_OFFSET_LSB (Address 0x32) to set the offset value applied to High Resolution L Measurements. 0x00: default value

8.6.27 Register LHR_CONFIG (address = 0x34) [reset = 0x00]
Figure 39. Register LHR_CONFIG

7	6	5	4	3	2	1	0
RESERVED						SENSOR_DIV	
R/W						R/W	

LEGEND: R/W = Read/Write; R = Read only; -n = value after reset

Table 29. Register LHR_CONFIG Field Descriptions

Bit	Field	Type	Reset	Description
7:2	RESERVED	R/W		Reserved. Set to b00'0000
1:0	SENSOR_DIV	R/W		Sensor Clock Divider Setting Divide the sensor frequency by programmed divider. This divider can be used to set the sensor frequency lower than the reference frequency. Refer to Sensor Input Divider for more details. b00: Sensor Frequency not divided (default value) b01: Sensor Frequency divided by 2 b10: Sensor Frequency divided by 4 b11: Sensor Frequency divided by 8

8.6.28 Register LHR_DATA_LSB (address = 0x38) [reset = 0x00]
Figure 40. Register LHR_DATA_LSB

7	6	5	4	3	2	1	0
LHR_DATA[7:0]							
R							

LEGEND: R/W = Read/Write; R = Read only; -n = value after reset

Table 30. Register LHR_DATA_LSB Field Descriptions

Bit	Field	Type	Reset	Description
7:0	LHR_DATA[7:0]	R		High Resolution L-Measurement Conversion Result Combine with values in Registers LHR_DATA_MID (Address 0x39) and LHR_DATA_MSB (Address 0x3A) to determine conversion result. $f_{\text{SENSOR}} = f_{\text{CLKIN}} \times \text{SENSOR_DIV} \times \text{LHR_DATA} \div 2^{24}$ NOTE: The LHR_DATA registers must be read in the sequence 0x38 first, then 0x39, and last 0x3A for data coherency.

8.6.29 Register LHR_DATA_MID (address = 0x39) [reset = 0x00]
Figure 41. Register LHR_DATA_MID

7	6	5	4	3	2	1	0
LHR_DATA[15:8]							
R							

LEGEND: R/W = Read/Write; R = Read only; -n = value after reset

Table 31. Register LHR_DATA_MID Field Descriptions

Bit	Field	Type	Reset	Description
7:0	LHR_DATA[15:8]	R		High Resolution L-Measurement Conversion Result Combine with values in Registers LHR_DATA_LSB (Address 0x38) and LHR_DATA_MSB (Address 0x3A) to determine conversion result. NOTE: Register LDR_DATA_LSB must be read prior to this register and LHR_DATA_MSB to ensure data coherency.

8.6.30 Register LHR_DATA_MSB (address = 0x3A) [reset = 0x00]
Figure 42. Register LHR_DATA_MSB

7	6	5	4	3	2	1	0
LHR_DATA[23:16]							
R							

LEGEND: R/W = Read/Write; R = Read only; -n = value after reset

Table 32. Register LHR_DATA_MSB Field Descriptions

Bit	Field	Type	Reset	Description
7:0	LHR_DATA[23:16]	R		High Resolution L-Measurement Conversion Result Combine with values in Registers LHR_DATA_LSB (Address 0x38) and LHR_DATA_MID (Address 0x39) to determine conversion result. NOTE: Register LDR_DATA_LSB must be read prior to LHR_DATA_MID and this register to ensure data coherency.

8.6.31 Register LHR_STATUS (address = 0x3B) [reset = 0x00]
Figure 43. Register LHR_STATUS

7	6	5	4	3	2	1	0
UNUSED			ERR_ZC	ERR_OR	ERR_UR	ERR_OF	LHR_DRDY
R			R	R	R	R	R

LEGEND: R/W = Read/Write; R = Read only; -n = value after reset

Table 33. Register LHR_STATUS Field Descriptions

Bit	Field	Type	Reset	Description
7:5	UNUSED	R		No Function
4	ERR_ZC	R		Zero Count Error Zero count errors are applicable for LHR measurements and indicate that no cycles of the sensor occurred in the programmed measurement interval. This indicates either a sensor error or the sensor frequency is too low. This field is updated after register 0x38 has been read. b0: No Zero Count error has occurred for the last LHR conversion result read. b1: A Zero Count error has occurred.
3	ERR_OR	R		Conversion Over-range Error Conversion over-range errors are applicable for LHR measurements and indicate that the sensor frequency exceeded the reference frequency. This field is updated after register 0x38 has been read. b0: No Conversion Over-range error has occurred for the last LHR conversion result read. b1: A Conversion Over-range error has occurred.

Table 33. Register LHR_STATUS Field Descriptions (continued)

Bit	Field	Type	Reset	Description
2	ERR_UR	R		Conversion Under-range Error Conversion under-range errors are applicable for LHR measurements and indicate that the output code is negative; this occurs when programmed LHR offset register value is too large. This field is updated after register 0x38 has been read. b0: No Conversion Under-range error has occurred for the last LHR conversion result read. b1: A Conversion Under-range error has occurred.
1	ERR_OF	R		Conversion Over-flow Error Conversion over-flow errors are applicable for LHR measurements and indicate that the sensor frequency is too close to the reference frequency. This field is updated after register 0x38 has been read. b0: No Conversion Over-flow error has occurred for the last LHR conversion result read. b1: A Conversion Over-flow error has occurred.
0	LHR_DRDY	R		LHR Data Ready b0: Unread LHR conversion data is available. This field is set to 0 at the end of an LHR conversion and remains asserted until a read of register 0x38. b1: No unread LHR conversion data is available.

8.6.32 Register RID (address = 0x3E) [reset = 0x02]
Figure 44. Register RID

7	6	5	4	3	2	1	0
V_ID					RID		
R					R		

LEGEND: R/W = Read/Write; R = Read only; -n = value after reset

Table 34. Register RID Field Descriptions

Bit	Field	Type	Reset	Description
7:3	V_ID	R		DEVICE ID Returns fixed value indicating device ID. 0x00: indicates LDC1101 (default value)
2:0	RID	R		RID Returns device RID. b010: Default value

8.6.33 Register DEVICE_ID (address = 0x3F) [reset = 0xD4]
Figure 45. Register DEVICE_ID

7	6	5	4	3	2	1	0
CHIP_ID							
R							

LEGEND: R/W = Read/Write; R = Read only; -n = value after reset

Table 35. Register DEVICE_ID Field Descriptions

Bit	Field	Type	Reset	Description
7:0	CHIP_ID	R		CHIP_ID Returns fixed value indicating device Family ID. 0xD4: indicates LDC1101 family (default value)

9 Application and Implementation

NOTE

Information in the following applications sections is not part of the TI component specification, and TI does not warrant its accuracy or completeness. TI's customers are responsible for determining suitability of components for their purposes. Customers should validate and test their design implementation to confirm system functionality.

9.1 Application Information

9.1.1 Theory of Operation

An AC current flowing through an inductor will generate an AC magnetic field. If a conductive material, such as a metal object, is brought into the vicinity of the inductor, the magnetic field will induce a circulating current (eddy current) on the surface of the conductor. The eddy current is a function of the distance, size, and composition of the conductor.

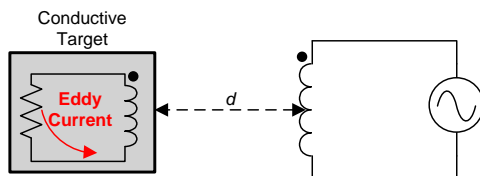

Figure 46. Conductor in an AC Magnetic Field

The eddy current generates its own magnetic field, which opposes the original field generated by the inductor. This effect can be considered as a set of coupled inductors, where the inductor is the primary winding and the eddy current in the conductor represents the secondary winding. The coupling between the windings is a function of the inductor, and the resistivity, distance, size, and shape of the conductor.

To minimize the current required to drive the inductor, a parallel capacitor is added to create a resonant circuit, which will oscillate at a frequency given by Equation 1 when energy is injected into the circuit. In this way, the LDC1101 only needs to compensate for the parasitic losses in the sensor, represented by the series resistance R_S of the LC tank. The oscillator is then restricted to operating at the resonant frequency of the LC circuit and injects sufficient energy to compensate for the loss from R_S .

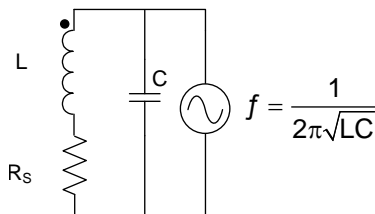

Figure 47. LC Tank

The resistance and inductance of the secondary winding caused by the eddy current can be modeled as a distant dependent resistive and inductive component on the primary side (coil). We can then represent the circuit as an equivalent parallel circuit, as shown in Figure 48.

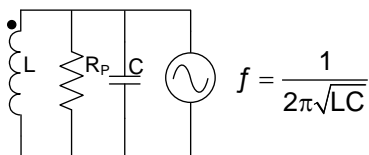

Figure 48. Equivalent Parallel Circuit

The value of R_P can be calculated with:

Application Information (continued)

$$R_P = \frac{L}{R_S C}$$

where

- R_S is the AC series resistance at the frequency of operation.
- C is the parallel capacitance
- L is the inductance

(2)

R_P can be viewed as the load on the sensor driver; this load corresponds to the current drive needed to maintain the oscillation amplitude. The position of a target can change R_P by a significant amount, as shown in [Figure 49](#). The value of R_P can then be used to determine the position of a conductive target. If the value of R_P is too low, then the sensor driver will not be able to maintain sufficient oscillation amplitude.

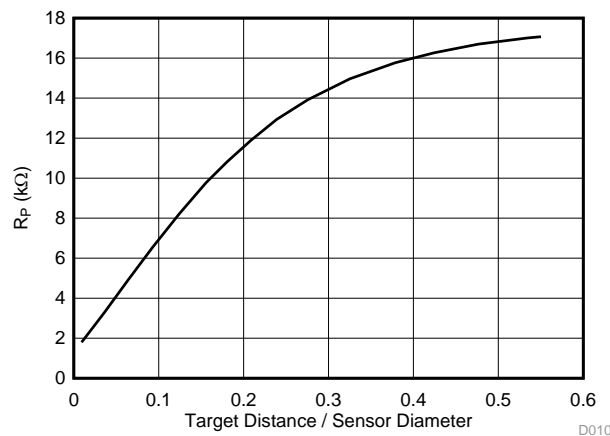
Figure 49. R_P vs Target Distance for a 14 mm Diameter Sensor
9.1.2 RP+L Mode Calculations

For many systems which use the LDC1101, the actual sensor R_P , sensor frequency, or sensor inductance is not necessary to determine the target position; typically the equation of interest is:

$$\text{Position}_{\text{Target}} = f(\text{RP_DATA}) \text{ or } \text{Position}_{\text{Target}} = f(\text{L_DATA})$$

where

- RP_DATA is the contents of registers 0x21 and 0x22
- L_DATA is the contents of registers 0x23 and 0x24

(3)

These Position equations are typically system dependent. For applications where the Sensor R_P in Ω s needs to be calculated, use [Equation 4](#):

$$R_P = \frac{R_{P_{\text{MAX}}} \times R_{P_{\text{MIN}}}}{R_{P_{\text{MAX}}} \left(1 - \frac{\text{RPDATA}}{2^{16} - 1} \right) + R_{P_{\text{MIN}}} \frac{\text{RPDATA}}{2^{16} - 1}}$$

where

- RPDATA is the contents of RP_DATA_MSB and RP_DATA_LSB (registers 0x21 and 0x22),
- $R_{P_{\text{MIN}}}$ is the value set by RP_MIN in register RP_SET (register 0x01), and
- $R_{P_{\text{MAX}}}$ is the value set by RP_MAX in register RP_SET (register 0x01).

(4)

For example, with device settings of:

- $R_{P_{\text{MIN}}}$ set to 1.5 kΩ, and
- $R_{P_{\text{MAX}}}$ set to 12 kΩ.

If $\text{RPDATA} = 0x33F1$ (register 0x21 = 0xF1 and register 0x22 = 0x33), which is 13297 decimal, then the sensor $R_P = 1.824$ kΩ.

Application Information (continued)

If R_PMAX_DIS (Register 0x01-b[7]) is set, then the equation is simply:

$$R_p = \frac{R_{P_{MIN}}}{\left(1 - \frac{RPDATA}{2^{16} - 1}\right)} \tag{5}$$

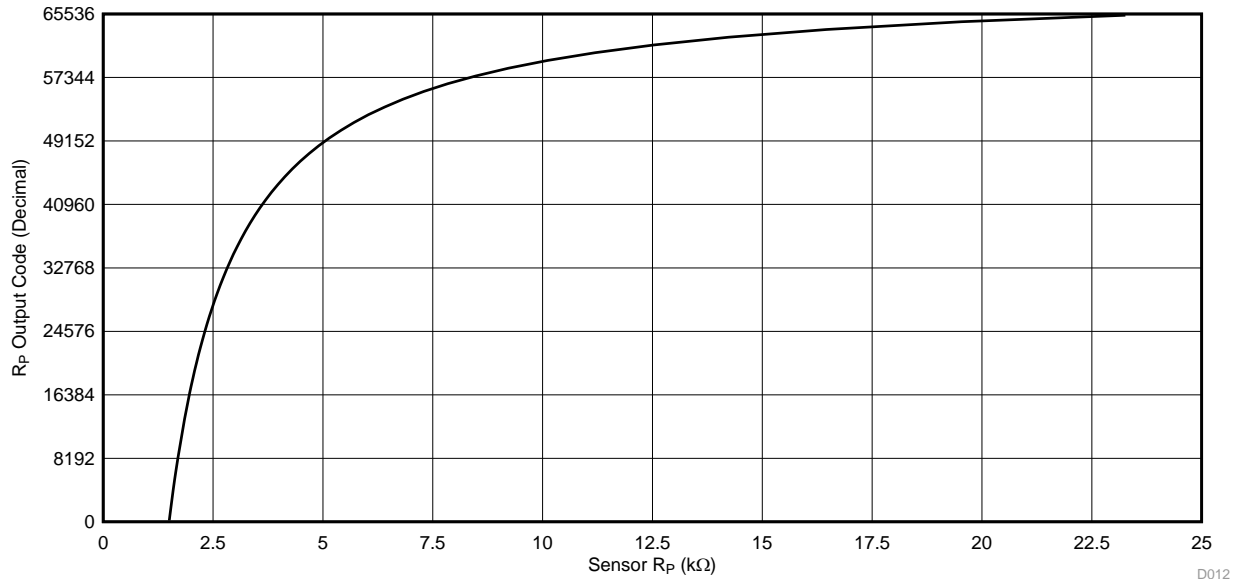

Figure 50. LDC1101 R_p Transfer Curve with R_PMIN = 1.5 kΩ and R_PMAX = 24 kΩ

The sensor frequency in Hz can be calculated from [Equation 6](#):

$$f_{SENSOR} = \frac{f_{CLKIN} \times RESP_TIME}{3 \times L_DATA}$$

where

- f_{CLKIN} is the frequency input to the CLKIN pin,
- L_DATA is the contents of registers 0x23 and 0x24, and
- RESP_TIME is the programmed response time in register 0x04.

The inductance in Henrys can then be determined from [Equation 7](#):

$$L_{SENSOR} = \frac{1}{C_{SENSOR} \times (2\pi f_{SENSOR})^2}$$

where

- C_{SENSOR} is the fixed sensor capacitance in Farads, and
- f_{SENSOR} is the measured sensor frequency, as calculated in [Equation 6](#) above.

Application Information (continued)

Figure 51. Inductance vs Normalized Target Distance for an Example Sensor

D013

9.1.3 LDC1101 R_p Configuration

Setting the RP_MIN and RP_MAX parameters is necessary for proper operation of the LDC1101; the LDC1101 may not be able to effectively drive the sensor with incorrect settings, as the sensor amplitude will be out of the valid operation region. The LDC1101EVM GUI and the LDC Excel[®] tools spreadsheet (<http://www.ti.com/lit/zip/slyc137>) can be used to calculate these parameters in an efficient manner.

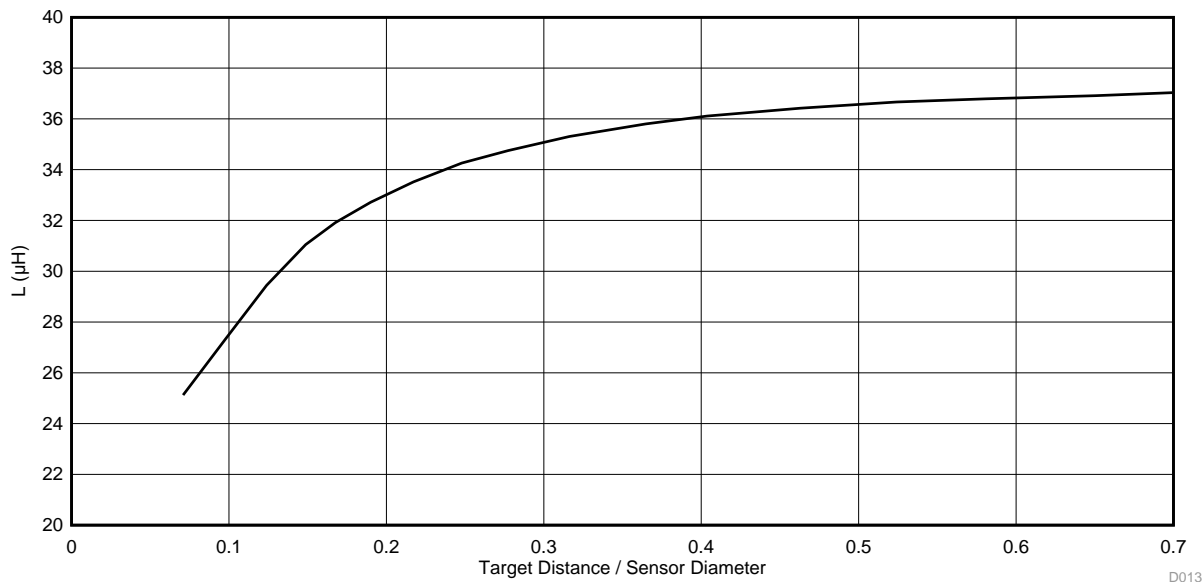
For R_p measurements, the following register settings must be set as follows:

- ALT_CONFIG.LOPTIMAL(register 0x05-bit0) = 0
 - D_CONFIG.DOK_REPORT (register 0x0C-bit0) = 0
1. Ensure that the sensor characteristics are within the Sensor boundary conditions:
 - (a) $500 \text{ kHz} < f_{\text{SENSOR}} < 10 \text{ MHz}$
 - (b) $100 \text{ pF} < C_{\text{SENSOR}} < 10 \text{ nF}$
 - (c) $1 \text{ } \mu\text{H} < L_{\text{SENSOR}} < 500 \text{ } \mu\text{H}$
 2. Measure the sensor's resonance impedance with minimal target interaction (R_{PD∞}). The minimal target interaction occurs when the target is farthest away from the sensor for axial sensing solutions or when the target coverage of the sensor is at a minimum for rotational or lateral sensing. Select the appropriate setting for R_PMAX (register 0x01-bits [5:4]):

$$R_{\text{PD}\infty} \leq R_{\text{P}MAX} \leq 2R_{\text{PD}\infty}$$
 3. Measure the sensor's resonance impedance with the target closest to the sensor (R_{PD0}) as required by the application. Select the largest R_PMIN setting that satisfies:
 - (a) $R_{\text{P}MIN} < 0.8 \times R_{\text{PD}0}$
 - (b) If the required R_PMIN is smaller than 750 Ω, R_{PD0} must be increased to be compliant with this boundary condition. This can be done by one or more of the following:
 - (a) increasing f_{SENSOR}
 - (b) increasing the minimum distance between the target and the sensor
 - (c) reducing the R_S of the sensor by use of a thicker trace or wire
 4. Check if the worst-case Sensor quality factor $Q_{\text{MIN}} = R_{\text{P}MIN} \times \sqrt{C_{\text{SENSOR}}/L_{\text{SENSOR}}}$ is within LDC1101's operating range:
 - (a) $10 \leq Q_{\text{MIN}} \leq 400$
 - (b) If $Q_{\text{MIN}} < 10$, for a fixed f_{SENSOR} , increase C_{SENSOR} and decrease L_{SENSOR} .
 - (c) If $Q_{\text{MIN}} > 400$, for a fixed f_{SENSOR} , decrease C_{SENSOR} and increase L_{SENSOR} .
 - (d) Alternatively the user may choose to not change the current Sensor parameters, but to increase R_{p_D0}.

Application Information (continued)

If the R_P of the sensor is greater than 75 k Ω , R_P measurement accuracy may be improved by setting RP_{MAX_DIS} to 1.

9.1.4 Setting Internal Time Constant 1

R_P Measurements require configuration of the TC1 and TC2 registers. There are several programmable capacitance and resistance values. Set Time Constant 1 based on minimum sensor frequency:

$$R_1 \times C_1 = \frac{\sqrt{2}}{\pi V_{AMP} f_{SENSOR-MIN}}$$

where

- $f_{SENSOR-MIN}$ is the minimum sensor frequency encountered in the system; typically this occurs with no target present.
- V_{AMP} is sensor amplitude of 0.6V,
- R_1 is the programmed setting for TC1.R1 (register 0x03-bits[4:0]), and
- C_1 is the programmed setting for TC1.C1 (register 0x03-bits[7:6])

(8)

The acceptable range of R_1 is from 20.6 k Ω to 417.4 k Ω . If several combinations of R_1 and C_1 are possible, it is recommended to use the largest capacitance setting for C_1 that fits the constraints of [Equation 8](#), as this will provide improved noise performance.

9.1.5 Setting Internal Time Constant 2

Set the Time Constant 2 (register 0x03) using [Equation 9](#):

$$R_2 \times C_2 = 2 \times RP_{MIN} \times C_{SENSOR}$$

where

- C_{SENSOR} is the parallel capacitance of the sensor.
- RP_{MIN} is the LDC1101 setting determined in [LDC1101 \$R_P\$ Configuration](#) (for example, use 1.5 k Ω when $RP_{SET.RP_MIN} = b110$),
- R_2 is the programmed setting for TC2.R2 (register 0x03-bits[5:0]), and
- C_2 is the programmed setting for TC2.C2 (register 0x03-bits[7:6]).

(9)

The acceptable range of R_2 is from 24.60 k Ω to 834.8 k Ω . If several combinations of R_2 and C_2 are possible, it is recommended to program the larger capacitance setting for C_2 that fits the constraints of [Equation 9](#), as this will provide improved noise performance.

9.1.6 MIN_FREQ and Watchdog Configuration

The LDC1101 includes a watchdog timer which monitors the sensor oscillation. While in active mode, if no sensor oscillation is detected, the LDC1101 will set $STATUS.NO_SENSOR_OSC$ (register 0x20:bit7), and attempt to restart the oscillator. This restart will reset any active conversion.

The watchdog waits an interval of time based on the setting of $DIG_CONF.MIN_FREQ$ (register 0x04:bits[7:4]). The MIN_FREQ setting is also used to configure the startup of oscillation on the sensor. Select the $DIG_CONF.MIN_FREQ$ (register 0x04:bits[7:4]) setting closest to the minimum sensor frequency; this setting is used for internal watchdog timing. If the watchdog determines the sensor has stopped oscillating, it will report the sensor has stopped oscillating in $STATUS.NO_SENSOR_OSC$ (register 0x20-bit7). If the $DIG_CONF.MIN_FREQ$ is set too low, then the LDC1101 will take a longer time interval to report that the sensor oscillation has stopped.

If the $DIG_CONF.MIN_FREQ$ is set too high, then the watchdog may incorrectly report that the sensor has stopped oscillating and attempt to restart the sensor oscillation.

When the watchdog determines that the sensor has stopped oscillating, the LHR conversion results will contain 0xFFFFF.

Application Information (continued)

9.1.7 RP+L Sample Rate Configuration with RESP_TIME

The RP+L sample rate can be adjusted by setting by DIG_CONF.RESP_TIME (register 0x04:bits[2:0]). The Response time can be configured from 192 to 6144 cycles of the sensor frequency. Higher values of Response time will have a slower sample rate, but produce a higher resolution conversion.

$$\text{Conversion Time (s)} = \frac{\text{Response Time}}{3 \times f_{\text{SENSOR}}} \quad (10)$$

9.1.8 High Resolution Inductance Calculation (LHR mode)

For many systems which use the LDC1101, the actual sensor frequency or sensor inductance is not necessary to determine the target position. Should the sensor frequency in Hz need to be determined, use [Equation 11](#):

$$f_{\text{SENSOR}} = \frac{2^{\text{SENSORDIV}} \times f_{\text{CLKIN}} (\text{LHRDATA} + \text{LHROFFSET} \times 2^8)}{2^{24}}$$

where

- LHRDATA is the contents of registers 0x38, 0x39, and 0x3A,
- LHROFFSET is the programmed contents of registers 0x32 and 0x33,
- SENSOR_DIV is the contents of LHR_CONFIG.SENSOR_DIV (register 0x34-bit[1:0]), and
- f_{CLKIN} is the frequency input to the CLKIN pin: ensure that it is within the specified limits of 1 MHz to 16 MHz. (11)

Note that LHR_DATA=0x0000000 indicates a fault condition or that the LDC1101 has never completed an LHR conversion.

The inductance in Henrys can then be determined from the sensor frequency with [Equation 12](#):

$$L_{\text{SENSOR}} = \frac{1}{C_{\text{SENSOR}} \times (2\pi f_{\text{SENSOR}})^2}$$

where

- C_{SENSOR} is the fixed sensor capacitance, and
- f_{SENSOR} is the measured sensor frequency, as calculated above. (12)

Example with the device set to:

- LHR_OFFSET = 0x00FF (register 0x32 = 0xFF, and 0x33 = 0x00)
- $f_{\text{CLKIN}} = 16$ MHz
- SENSOR_DIV = b'01 (divide by 2)

and the conversion result is:

LHR_DATA = 0x123456 (register 0x38 = 0x56, register 0x39 = 0x34, register 0x3A = 0x12)

Then entering LHR_DATA = 0x123456 = 1193046 (decimal) into [Equation 11](#):

$$f_{\text{SENSOR}} = \frac{2^1 \times 16\text{MHz} (1193046 + 255 \times 2^8)}{2^{24}} \quad (13)$$

Results in $f_{\text{SENSOR}} = 2.400066$ MHz.

9.1.9 LHR Sample Rate Configuration with RCOUNT

The conversion time represents the number of reference clock cycles used to measure the sensor frequency. The LHR mode conversion time is set by the Reference count in LHR_RCOUNT.RCOUNT (registers 0x30 & 0x31). The LHR conversion time is:

$$t_{\text{CONV}} = \frac{(55 + \text{RCOUNT} \times 16)}{f_{\text{CLKIN}}} \quad (14)$$

Application Information (continued)

The 55 is due to post-conversion processing and is a fixed value. The reference count value must be chosen to support the required number of effective bits (ENOB). For example, if an ENOB of 13 bits is required, then a minimum conversion time of $2^{13} = 8192$ clock cycles is required. 8192 clock cycles correspond to a RCOUNT value of 0x0200.

Higher values for RCOUNT produce higher resolution conversions; the maximum setting, 0xFFFF, is required for full resolution.

9.1.10 Setting RPMIN for LHR Measurements

Configure the R_P measurement as shown previously for L measurements. If only L measurements are necessary, then the R_P measurement can be disabled by setting:

- ALT_CONFIG.LOPTIMAL(register 0x05-bit0) = 1
- D_CONFIG.DOK_REPORT (register 0x0C-bit0) = 1

Setting these bits disable the sensor modulation used by the LDC1101 to measure R_P and can reduce L measurement noise. When the R_P modulation is disabled, the LDC1101 will drive a fixed current level into the sensor. The current drive is configured by RP_SET.RPMIN (address 0x01:bits[2:0]). The sensor amplitude must remain between 0.25 Vpk and 1.25 Vpk for accurate L measurements. Use Table 36 to determine the appropriate RPMIN setting, based on the variation in sensor R_P . If multiple RPMIN values cover the Sensor R_P , use the higher current drive setting. The equation to determine sensor amplitude is:

$$R_P = \frac{\pi \times V_{amp}}{4 \times I_{DRIVE}} \quad (15)$$

Table 36. LHR RPMIN Settings when Sensor R_P Modulation is Disabled

RPMIN SETTING	RPMIN FIELD VALUE	SENSOR DRIVE (μ A)	MINIMUM SENSOR R_P (k Ω)	MAXIMUM SENSOR R_P (k Ω)
0.75 k Ω	b111	600	0.53	1.65
1.5 k Ω	b110	300	1.1	3.3
3 k Ω	b101	150	2.1	6.5
6 k Ω	b100	75	4.2	13.1
12 k Ω	b011	37.5	8.4	26.2
24 k Ω	b010	18.7	16.9	52.4
48 k Ω	b001	9.4	33.9	105
96 k Ω	b000	4.7	67.9	209

For example, with a sensor that has an R_P which can vary between 2.7 k Ω to 5 k Ω , the appropriate setting for RPMIN would be 3 k Ω (RP_SET.RPMIN = b101). For more information on Sensor R_P and sensor drive, refer to *Configuring Inductive-to-Digital-Converters for Parallel Resistance (RP) Variation in L-C Tank Sensors*(SNA0221).

9.1.11 Sensor Input Divider

The reference clock frequency should be greater than 4 times the sensor frequency for optimum measurement resolution:

$$f_{CLKIN} > 4f_{SENSOR-MAX}$$

For higher sensor frequencies, this relationship may not be realizable without the sensor divider. Set the sensor divider to an appropriate value to produce an effective reduction in the sensor frequency:

$$f_{CLKIN} > 4f_{SENSOR-MAX} \div \text{SENSOR_DIV}$$

9.1.12 Reference Clock Input

Use a clean, low jitter, 40-60% duty cycle clock input with an amplitude swing within the range of V_{DD} and GND; proper clock impedance control, and series or parallel termination is recommended. The rise and fall time should be less than 5 ns. Do not use a spread-spectrum or modulated clock.

For optimum L measurement performance, it is recommended to use the highest reference frequency (16 MHz). LHR conversions will not start until a clock is provided on CLKIN.

9.1.13 INTB Reporting on SDO

INTB is a signal generated by the LDC1101 that reports a change in device status. When `INTB_MODE.INTB2SDO=1` (register 0x0A:bit7), INTB is multiplexed onto the SDO pin. Once the reporting is enabled, select the desired signal to report by setting `INTB_MODE.INTB_FUNC` (register 0x0A:bit[5:0]).

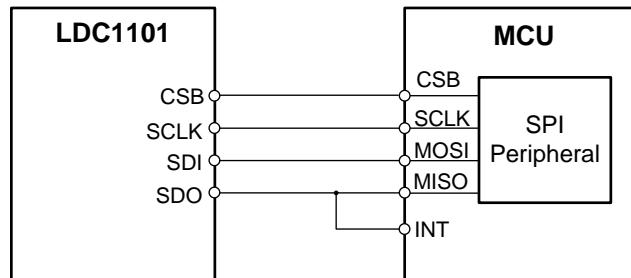

Figure 52. SDO/INTB Connection to MCU

For many microcontrollers, the MISO signal on the SPI peripheral cannot provide the desired interrupt functionality. One method to use the INTB functionality is to connect a second GPIO which triggers on a falling edge, as shown in [Figure 51](#). [Table 37](#) describes the signal functionality that can be programmed onto INTB.

Table 37. INTB Signal Options

SIGNAL	INTB_FUNC (0x0A:bit[5:0])	FUNCTIONALITY	SWITCH OUTPUT TYPE
LHR Data Ready (LHR-DRDY)	b10'0000	Indicates new High-Resolution Inductance (LHR) conversion data is available.	Latching
L_HI_LO	b01'0000	L Comparator with hysteresis	Hysteresis
L_TH_HI	b00'1000	Latching L High threshold compare	Latching
RP+L Data Ready (RPL-DRDY)	b00'0100	Indicates new RP+L conversion data is available.	Pulse
RP_HI_LO	b00'0010	R _P Comparator with hysteresis	Hysteresis
RP_TH_HI	b00'0001	Latching R _P High threshold compare	Latching
None	b00'0000	No INTB reporting – SDO pin only provides SDO functionality.	N/A

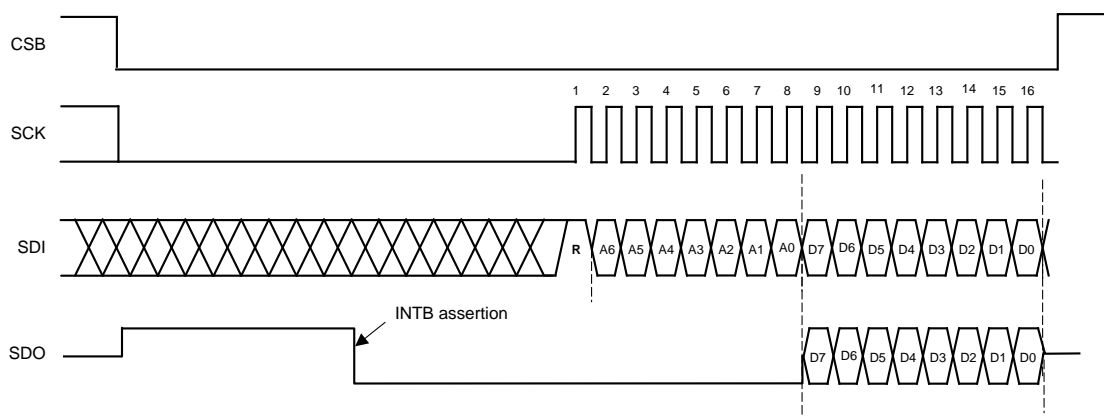

Figure 53. Example INTB Signal on SDO

When `INTB_MODE.INTB2SDO` (register 0x0A:bit7) = 0, the SDO pin is in a Hi-Z state until the 8th falling edge of SCLK after CSB goes low. When INTB reporting is enabled by setting `INTB_MODE.INTB2SDO = 1`, after CSB goes low, the SDO pin will go high and remain high until:

- the event configured by INTB_MODE.INTB_FUNC occurs,
- an SPI read transaction is initiated, or
- CSB is deasserted (pulled high)

9.1.14 DRDY (Data Ready) Reporting on SDO

Completion of a conversion can be indicated on the SDO pin by reporting the DRDY signal – there is a conversion complete indicator for the RP+L conversion (RPL-DRDY), and a corresponding conversion complete indicator for the LHR mode (LHR-DRDY).

When LHR-DRDY or RPL-DRDY is reported on SDO, the SDO pin is asserted on completion of a conversion. While in this mode, conversion data can be corrupted if a new conversion completes while reading the output data registers. To avoid data corruption, it is important to retrieve the conversion rates via SPI quicker than the shortest conversion interval, and to ensure that the data is retrieved before a new conversion could possibly complete.

When INTB is reporting RPL-DRDY, if CSB is held low for longer than one conversion cycle, INTB will be deasserted approximately 100 ns to 2 μ s prior to the completion of each conversion. The deassertion time is proportional to $1/f_{\text{SENSOR}}$.

When INTB is reporting LHR-DRDY, if CSB is held low for longer than one conversion cycle, INTB will assert on completion of the first conversion and remain low – and it will remain asserted until cleared. To clear the LHR_DRDY signal, read the LHR_DATA registers.

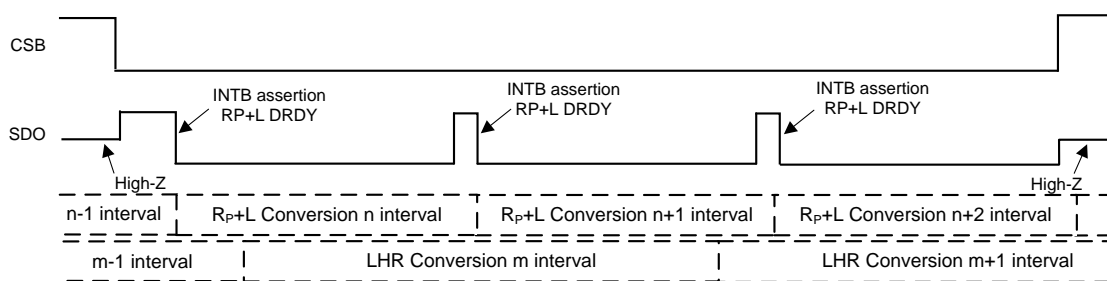

Figure 54. Reporting RPL-DRDY on INTB/SDO

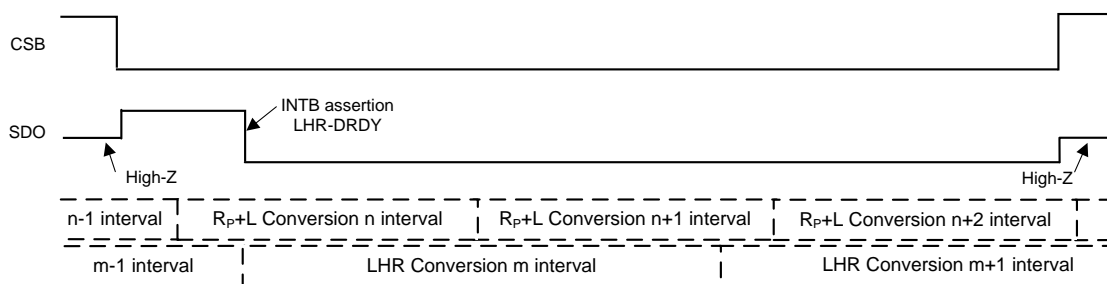

Figure 55. Reporting LHR-DRDY on INTB/SDO

Note that the conversion interval for an LHR measurement is asynchronous to the conversion interval for an R_p+L measurement, therefore the LHR-DRDY signal cannot be used to determine when to read R_p+L conversion results, and vice versa.

9.1.15 Comparator Functionality

The LDC1101 provides comparator functionality, in which the R_p+L conversion results can be compared against two thresholds. The results of each R_p and L conversion can be compared against programmable thresholds and reported in the STATUS register. Note that the LHR conversion results cannot be used for comparator functionality.

In addition, the INTB signal can be asserted or deasserted when the conversion results increase above a Threshold High or decreases below a Threshold Low registers. In this mode, the LDC1101 essentially behaves as a proximity switch with programmable hysteresis. The threshold HI settings must be programmed to a higher value than the threshold LO registers (for example, if RP_THRESH_LO is set to 0x2000, RP_THRESH_HI should be programmed to 0x2001 or higher).

Either Latching and non-latching functions can be reported on INTB/SDO. The INTB signal can report a latching signal or a continuous comparison for each conversion result.

The Threshold setting registers (address 0x06:0x09 and 0x16:0x19) can be changed while the LDC1101 is in active conversion mode. It is recommended to change the register values using an extended SPI transaction as described in *SPI Programming*, so that the register updates can be completed in a shorter time interval. This functionality enables the LDC1101 to operate as a dynamic tracking switch. LDC1101 output codes can be readout in < 4 μs, and the set of active thresholds can be updated in <6 μs. It is not recommended to update the threshold registers more often than once per conversion interval of the LDC1101 (that is, do not change the threshold register values multiple times in a single conversion interval).

To clear a latched INTB signal, set INTB_MODE = 0x80; it is not necessary for the LDC1101 to be in Sleep mode to clear the latched output; the INTB_MODE can be changed while the LDC1101 is in active mode. After clearing the latched output, re-enabling the INTB_FUNC can be done while in active mode.

Table 38. Comparator Options

FUNCTION	THRESHOLD HIGH	THRESHOLD LOW	STATUS REPORTING	INTB/SDO REPORTING
R _P Comparator with hysteresis	RP_THRESH_HI (registers 0x06 & 0x07)	RP_THRESH_LO (registers 0x08 & 0x09)	RP_HI_LON (bit 4)	RP_HI_LO (INTB_MODE:INTB_FUNC=b00'0010)
R _P High threshold only (Latching)	RP_THRESH_HI (registers 0x06 & 0x07)	N/A	RP_HIN (bit 5)	RP_TH_HI (INTB_MODE:INTB_FUNC=b00'0001) Note that INTB/SDO will latch.
L Comparator with hysteresis	L_THRESH_HI (registers 0x16 & 0x17)	L_THRESH_LO (registers 0x18 & 0x19)	L_HI_LON (bit 2)	L_HI_LO (INTB_MODE:INTB_FUNC=b01'0000)
L High threshold compare only (Latching)	L_THRESH_HI (registers 0x18 & 0x19)	N/A	L_HIN (bit 3)	L_TH_HI (INTB_MODE:INTB_FUNC=b00'1000) Note that INTB/SDO will latch.

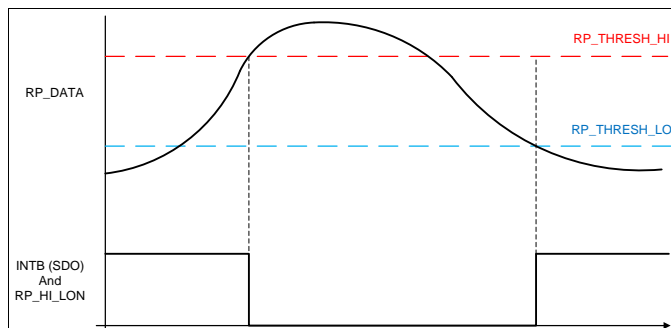

Figure 56. INTB/SDO Output Value for R_P Comparator with Hysteresis (INTB_FUNC=b00'0010)

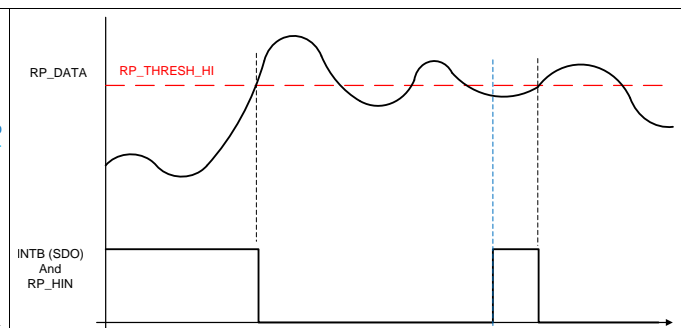

Figure 57. INTB/SDO Output for R_P Threshold High (INTB_FUNC=b00'00011)

9.2 Typical Application

Implementation of a system using the LDC1101 first requires determining the appropriate measurement to perform. Refer to http://e2e.ti.com/blogs_b/analogwire/archive/2015/02/11/inductive-sensing-should-i-measure-l-rp-or-both for guidance.

For systems that require measurement of R_p , set the following:

- Configure R_p settings as instructed in [LDC1101 \$R_p\$ Configuration](#).
- Set the internal time constants as detailed in [Setting Internal Time Constant 1](#) and [Setting Internal Time Constant 2](#).

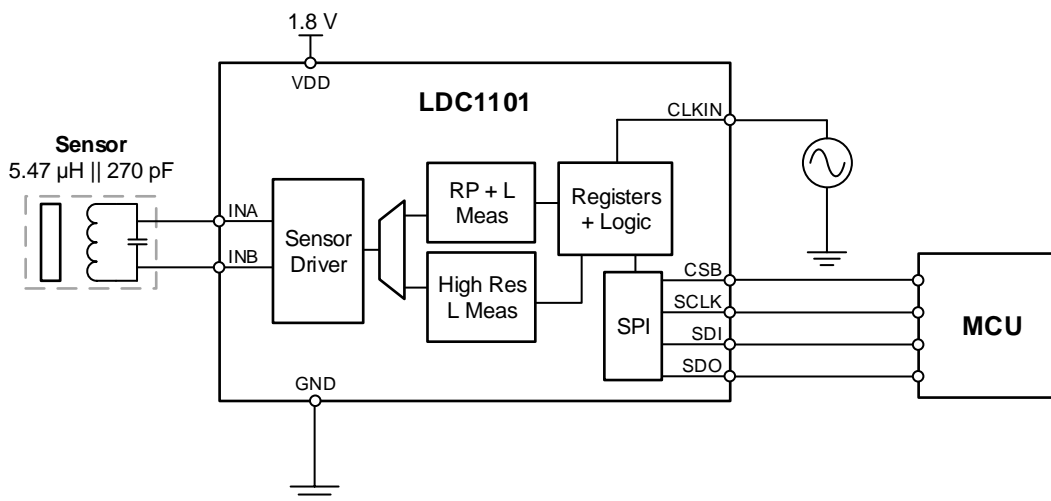

Figure 58. Example LDC1101 Typical Application

9.2.1 Design Requirements

Example of an axial measurement implementation using the LDC1101. In this example, the sensor is an inductor constructed of a multi-layer PCB coil in parallel with a COG grade surface mount capacitor. For this example, a 10 mm diameter Aluminum target of 1mm thickness is moved perpendicular to the plane of the sensor coil.

For this example, the target range of motion is from 1 mm to 3 mm distance from the sensor coil. The position of the target needs to be reported at a sample rate of 3 ksps. The PCB is a 4-layer construction with 0.1 mm (4 mils) minimum feature size.

9.2.2 Detailed Design Procedure

9.2.2.1 Device Configuration for R_p+L Measurement with an Example Sensor

The sensor described in [Table 39](#) meets the restrictions on size on construction. To use it for R_p+L measurement of a 10 mm diameter 1 mm thick Aluminum target moving axially with respect to the sensor:

Table 39. Example Sensor Characteristics

PARAMETER	MINIMUM TARGET INTERACTION	STRONGEST TARGET INTERACTION
Inductance	5.47 μ H	5.15 μ H
Inductor Outer Diameter	10 mm	
Number of Turns	17	
Trace Spacing/ Trace Width	0.1 mm / 0.16 mm	
Number of Layers/Separation	2 / 0.355 mm	
Sensor Capacitance	270 pF	
Sensor Frequency	4.11 MHz	4.27 MHz
R _S	3.20 Ω at 2.93 MHz	3.23 Ω at 4.27 MHz
R _P	6.33 k Ω at 2.93 MHz	5.91 k Ω at 4.27 MHz
Q at 2.9 MHz	45	42

This sensor is within the LDC1101 sensor boundary conditions for frequency, Q, and R_P. The first step is to determine the appropriate RPMIN/RPMAX and TC1/2 settings.

- Setting RPMAX has the constraint of $R_{PD\infty} \leq R_{P\text{MAX}} \leq 2R_{PD\infty}$
 $6.11 \text{ k}\Omega \leq R_{P\text{MAX}} \leq 12.22 \text{ k}\Omega \rightarrow$ Set RPMAX to 12 k Ω
- RPMIN setting using the constraint of $R_{P\text{MIN}} < 0.8 \times R_{PD0}$:
 $0.8 \times 3.20 \text{ k}\Omega = 2.6 \text{ k}\Omega \rightarrow$ Set RPMIN to 1.5 k Ω . Therefore, set RPMIN = 1.5 k Ω .
- Q Range: In step 4, the sensor Q range of 42 to 45 is within the operating range of 10 to 400. As the sensor Q value is below 50, it is not necessary to use RPMAX_DIS, and so RPMAX_DIS=0.
- Now set the Time Constant 1 using [Equation 8](#):
 $R1 \times C1 = 0.75026 \div 4.11 \text{ MHz} = 1.8255\text{E-}7\text{s}$
 Starting with the largest C1 value of 6 pF for best noise performance results in R1 = 30.5 k Ω .
 This is within the R1 range of 20.6 k Ω to 417.4 k Ω , and so C1 = 6 pF can be used.
 Picking the next higher programmable value for R1 \rightarrow Set R1 = 33.9 k Ω .
- Next, set the Time Constant 2 using [Equation 9](#):
 $R2 \times C2 = 2 \times 1.5 \text{ k}\Omega \times 270 \text{ pF} = 8.100\text{E-}7\text{s}$
 Starting with the largest C2 value of 24 pF (once again, for best noise performance) results in R2 = 33.75 k Ω .
 This is within the programmable R2 value of 24.60 k Ω to 834.8 k Ω , and so 24 pF can be used for C2.
 Picking the next higher programmable value for R2 \rightarrow Set R2 = 43.3 k Ω .
- Then configure the MIN_FREQ field. The sensor minimum frequency is 4.11 MHz, which occurs with the minimum target interaction. Therefore, MIN_FREQ is set to 14, which configures the watchdog for 4.0 MHz.
- Next, set the response time. Setting 6144 will provide the highest resolution R_P measurement with this sensor. With 6144 the sample rate will be at least 2.01 kSPS. To attain highest resolution with a sample rate of >3 kSPS, the response time setting should be 3072.
- All other device settings can be in their default values.

Table 40. LDC1101 Register Settings for RP+L Example Application

FIELD	FIELD SETTING	FIELD VALUE	REGISTER	REGISTER VALUE
RPMAX_DIS	disabled	b0	RP_SET (0x01)	0x36
RPMAX	12.0 k Ω	b011		
RPMIN	1.5 k Ω	b110		
C1	6 pF	b11	TC1 (0x02)	0xDE
R1	33.9 k Ω	b1'1110		
C2	24 pF	b11	TC2 (0x03)	0xFE
R2	43.3 k Ω	b11'1110		

Table 40. LDC1101 Register Settings for RP+L Example Application (continued)

FIELD	FIELD SETTING	FIELD VALUE	REGISTER	REGISTER VALUE
MIN_FREQ	4.0 MHz	b1110	DIG_CONF (0x04)	0xE6
RESP_TIME	3072	b110		
FUNC_MODE	active	b00	START_CONFIG (0x0B)	0x00

On power-up, the LDC1101 enters Sleep mode, which is a low power mode used to configure the LDC. If the LDC1101 is actively converting, write 0x01 to START_CONFIG (address 0x0B) to stop conversions before writing the settings above.

Once the LDC1101 is configured, the process to retrieve RP+L conversion results is:

1. Set the LDC1101 into conversion mode (active mode) by writing 0x00 to START_CONFIG (register 0x0B).
2. Poll STATUS.DRDYB (register 0x20:bit6) until it indicates a conversion result is present, or use the INTB signal reporting as described in [DRDY \(Data Ready\) Reporting on SDO](#).
3. If the desired measurement is R_P , then read back registers 0x21 and 0x22. The R_P output code is the contents of register 0x21 + 256 × (contents of register 0x22).
4. If the desired measurement is L, then read back registers 0x23 and 0x24. The L output code is the contents of register 0x23 + 256 × (contents of register 0x24). Reading both R_P and L is permitted, for a more efficient operation R_P and L registers can be retrieved in a single extended SPI transaction as described in [SPI Programming](#).
5. Process the conversion results on the MCU and repeat from step 2 if additional conversions are desired. If no additional conversions are required, place the LDC1101 into Sleep mode or Shutdown mode.

9.2.2.2 Device Configuration for LHR Measurement with an Example Sensor

Given a sensor with characteristics as shown in [Table 39](#), the steps to configure the LDC1101 for LHR measurements are:

1. Determine the device sample rate, based on system requirements, using [Equation 14](#). For this example, $f_{CLKIN} = 16$ MHz and a sample rate of 3 kSPS is necessary. The number of cycles of the f_{CLKIN} that closest fit the desired sample rate is determined by:

$$1/(3 \text{ kSPS}) = 333.3 \mu\text{s}$$
 subtracting the conversion post-processing time of 55 reference clock cycles ($55/16 \text{ MHz} = 3.437 \mu\text{s}$):

$$333.3 \mu\text{s} - 3.437 \mu\text{s} = 329.9 \mu\text{s} \rightarrow 16 \text{ MHz} \times 163.2 \mu\text{s} = 5278.34 \rightarrow 5278.34/16 = 329.9$$
 Programming RCOUNT to 330 (0x014A) results in a sample rate of 2.999 kSPS.
2. Next, set the sensor drive. If the sensor was already configured for RP+L measurements with the steps in [Device Configuration for RP+L Measurement with an Example Sensor](#), then the sensor drive is already configured and no additional steps are necessary.
3. If the sensor drive needs to be configured, from [Table 36](#), 3 kΩ is the appropriate setting for the sensor R_P range of 6.33 kΩ to 5.61 kΩ.

Table 41. LDC1101 Register Settings for LHR Example Application

FIELD	FIELD SETTING	FIELD VALUE	REGISTER	REGISTER VALUE
RPMAX_DIS	disabled	b0	RP_SET (0x01)	0x75
RPMAX	doesn't matter	b111		
RPMIN	1.5 kΩ	b101		
MIN_FREQ	4.0 MHz	b1110	DIG_CONF (0x04)	0xE7
RESP_TIME	don't care	b111		
RCOUNT	5280	330	LHR_RCOUNT_LSB (0x30)	0x4A
			LHR_RCOUNT_MSB (0x31)	0x01
FUNC_MODE	active	b00	START_CONFIG (0x0B)	0x00

Once the LDC1101 is configured, the process to retrieve LHR conversion results is:

1. Set the LDC1101 into conversion mode (active mode) by writing 0x00 to START_CONFIG (register 0x0B).
2. Poll LHR_STATUS.DRDYB (register 0x3B:bit0) until it indicates a conversion result is present, or use the INTB signal reporting as described in [DRDY \(Data Ready\) Reporting on SDO](#).
3. Read back registers 0x38, 0x39, and 0x3A. These registers can be retrieved in a single extended SPI transaction as described in [SPI Programming](#).
4. Process the conversion results on the MCU and repeat from step 2 if additional conversions are desired. If no additional conversions are required, place the LDC1101 into Sleep mode or Shutdown mode.

Both sets of conversion results can be retrieved when the conversions complete. Note that the RP+L conversions will not complete at the same time as LHR conversions.

9.2.3 Application Curves

The RCOUNT = 0x00FF curve, which corresponds to a sample rate of 3.87 ksps, will measure the target position with a slightly lower resolution than the RCOUNT = 0x014A used in this example. Over the target movement range of 3 mm, which corresponds to the normalized value of 0.3 on the Axial Measurement graph, the target position can be resolved to 4 μm .

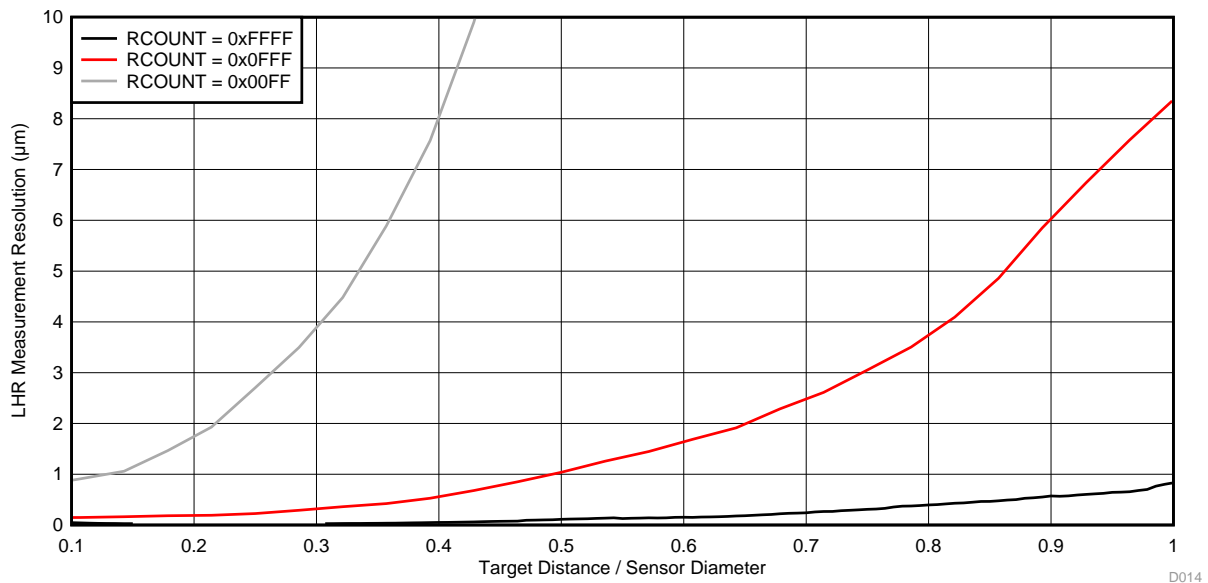

Figure 59. LHR Axial Measurement Resolution vs Normalized Distance for Aluminum Target

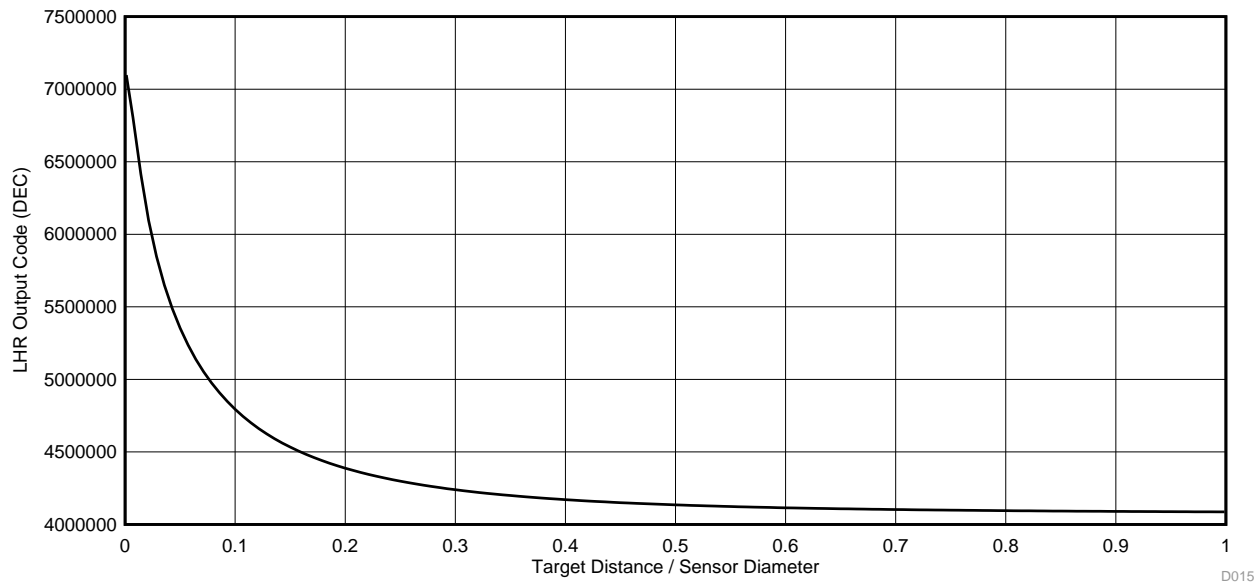

Figure 60. LHR Output Code vs Normalized Distance for Aluminum Target

D015

10 Power Supply Recommendations

A parallel set of 1 μF and 0.1 μF capacitors should be used to bypass V_{DD} , although it may be necessary to include a larger capacitor with systems which have a larger amount of supply variation. The smallest value capacitor should be placed as close as possible to the VDD pin. A ground plane is recommended to connect both the ground and the Die Attach Pad (DAP).

C_{LDO} capacitor should be nonpolarized and have an equivalent series resistance (ESR) less than 1 Ω , with a SRF of at least 24 MHz.

11 Layout

11.1 Layout Guidelines

The LDC1101 requires minimal external components for effective operation. Following good layout techniques - providing good grounding and clean supplies are critical for optimum operation. Due to the small physical size of the LDC1101, use of surface mount 0402 or smaller components can ease routing.

11.1.1 Ground and Power Planes

Ground and power planes are helpful for maintaining a clean supply to the LDC1101. In the layout shown in [Figure 61](#), a top-layer ground fill is also used for improved grounding.

11.1.2 CLKIN Routing

The CLKIN pin routing should maintain consistent impedance; typically this is 50 Ω , but can be adjusted based on board geometries. If a parallel termination resistor is used, it should be placed as close as possible to the CLKIN pin. Minimize layer changes and routing through vias for the CLKIN signal. Maintain an uninterrupted ground plane under the trace.

11.1.3 Capacitor Placement

The capacitor C_{LDO} should be placed as close as possible to the CLDO pin.

Place the bypass capacitors as close as possible to the VDD pin, with the smaller valued capacitor placed closer.

11.1.4 Sensor Connections

The sensor capacitor should be as close as possible to the sensor inductor. The INA and INB traces should be routed in parallel and as close as possible to each other to minimize coupling of noise. If cable is to be used, then INA and INB should be a twisted pair or in coaxial cable. The distance between the INA/INB pins and the sensor will affect the maximum possible sensor frequency. For some applications, it may be helpful to place small value capacitor (for example, 10 pF) from INA to ground and INB to ground; these capacitors should be located close to the INA and INB pins.

Refer to Application Note *LDC Sensor Design* ([SNOA930](#)) for additional information on sensor design.

11.2 Layout Example

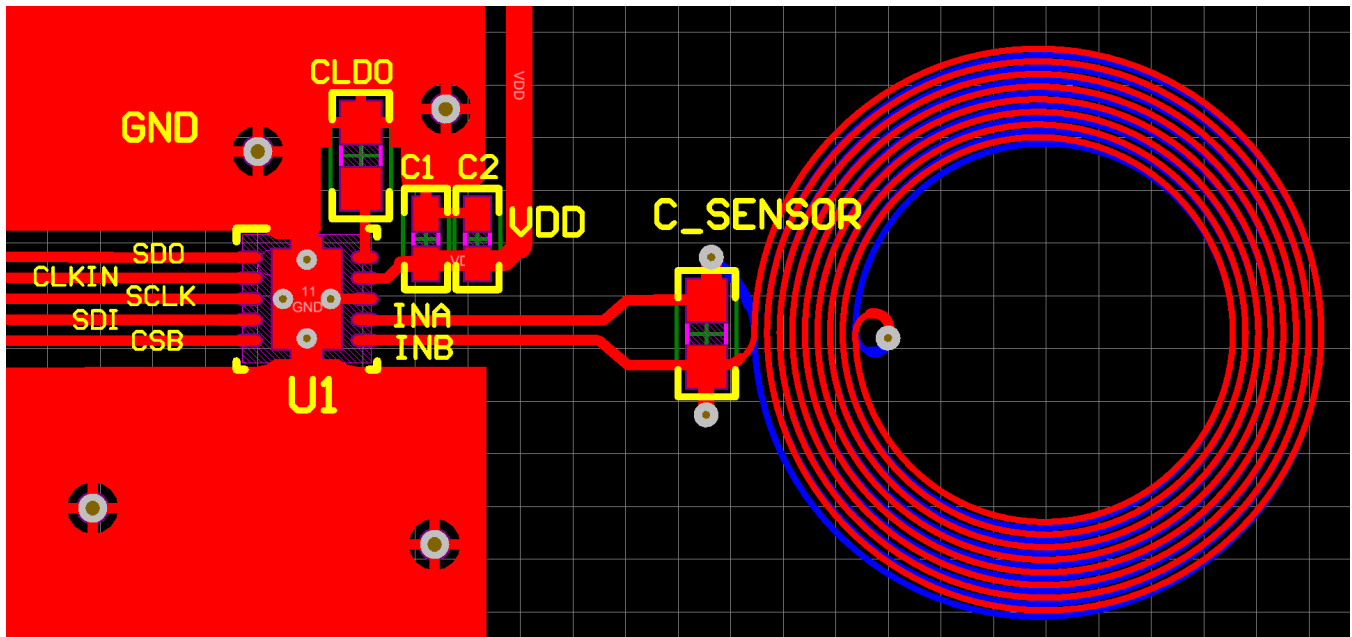

Figure 61. Layout Recommendations

12 器件和文档支持

12.1 器件支持

12.1.1 开发支持

要获取在线 LDC 系统设计工具，请访问德州仪器的 [Webench®](#) 工具

[LDC 计算器工具](#)提供了一系列在 MS Excel® 下运行的计算工具，这些工具对于 LDC 的系统开发非常有用。

12.2 文档支持

12.2.1 相关文档

有关 LDC 传感器设计的详细信息，请参见《[LDC 传感器设计应用报告](#)》（文献编号：[SNOA930](#)）。

有关使用 LDC 进行横向位置感测（其中目标点移动时与传感器保持一定高度的距离，然后测量偏差）的详细信息，请参见《[LDC1612/LDC1614 线性位置感测](#)》（文献编号：[SNOA931](#)）。LDC1101 LHR 模式的功能相当于单通道 LDC1612/LDC1614。

有关温度补偿的信息，请参见《[LDC1000 温度补偿](#)》（文献编号：[SNAA212](#)）。

12.3 社区资源

The following links connect to TI community resources. Linked contents are provided "AS IS" by the respective contributors. They do not constitute TI specifications and do not necessarily reflect TI's views; see TI's [Terms of Use](#).

TI E2E™ Online Community *TI's Engineer-to-Engineer (E2E) Community*. Created to foster collaboration among engineers. At e2e.ti.com, you can ask questions, share knowledge, explore ideas and help solve problems with fellow engineers.

Design Support *TI's Design Support* Quickly find helpful E2E forums along with design support tools and contact information for technical support.

12.4 商标

E2E is a trademark of Texas Instruments.

Webench is a registered trademark of Texas Instruments.

Excel is a registered trademark of Microsoft Corporation.

SPI is a trademark of Motorola.

All other trademarks are the property of their respective owners.

12.5 静电放电警告



这些装置包含有限的内置 ESD 保护。存储或装卸时，应将导线一起截短或将装置放置于导电泡棉中，以防止 MOS 门极遭受静电损伤。

12.6 术语表

[SLYZ022](#) — *TI 术语表*。

这份术语表列出并解释术语、首字母缩略词和定义。

13 机械、封装和可订购信息

以下页中包括机械、封装和可订购信息。 这些信息是针对指定器件可提供的最新数据。 这些数据会在无通知且不对本文档进行修订的情况下发生改变。 欲获得该数据表的浏览器版本，请查阅左侧的导航栏。

重要声明

德州仪器(TI)及其下属子公司有权根据 JESD46 最新标准,对所提供的产品和服务进行更正、修改、增强、改进或其它更改,并有权根据 JESD48 最新标准中止提供任何产品和服务。客户在下订单前应获取最新的相关信息,并验证这些信息是否完整且是最新的。所有产品的销售都遵循在订单确认时所提供的TI 销售条款与条件。

TI 保证其所销售的组件的性能符合产品销售时 TI 半导体产品销售条件与条款的适用规范。仅在 TI 保证的范围内,且 TI 认为有必要时才会使用测试或其它质量控制技术。除非适用法律做出了硬性规定,否则没有必要对每种组件的所有参数进行测试。

TI 对应用帮助或客户产品设计不承担任何义务。客户应对其使用 TI 组件的产品和应用自行负责。为尽量减小与客户产品和应用相关的风险,客户应提供充分的设计与操作安全措施。

TI 不对任何 TI 专利权、版权、屏蔽作品权或其它与使用了 TI 组件或服务的组合设备、机器或流程相关的 TI 知识产权中授予的直接或隐含权限作出任何保证或解释。TI 所发布的与第三方产品或服务有关的信息,不能构成从 TI 获得使用这些产品或服务的许可、授权、或认可。使用此类信息可能需要获得第三方的专利权或其它知识产权方面的许可,或是 TI 的专利权或其它知识产权方面的许可。

对于 TI 的产品手册或数据表中 TI 信息的重要部分,仅在没有对内容进行任何篡改且带有相关授权、条件、限制和声明的情况下才允许进行复制。TI 对此类篡改过的文件不承担任何责任或义务。复制第三方的信息可能需要服从额外的限制条件。

在转售 TI 组件或服务时,如果对该组件或服务参数的陈述与 TI 标明的参数相比存在差异或虚假成分,则会失去相关 TI 组件或服务的所有明示或暗示授权,且这是不正当的、欺诈性商业行为。TI 对任何此类虚假陈述均不承担任何责任或义务。

客户认可并同意,尽管任何应用相关信息或支持仍可能由 TI 提供,但他们将独立负责满足与其产品及其在应用中使用的 TI 产品相关的所有法律、法规和安全相关要求。客户声明并同意,他们具备制定与实施安全措施所需的全部专业技术和知识,可预见故障的危险后果、监测故障及其后果、降低有可能造成人身伤害的故障的发生机率并采取适当的补救措施。客户将全额赔偿因在此类安全关键应用中使用任何 TI 组件而对 TI 及其代理造成的任何损失。

在某些场合中,为了推进安全相关应用有可能对 TI 组件进行特别的促销。TI 的目标是利用此类组件帮助客户设计和创立其特有的可满足适用的功能安全性标准和要求的终端产品解决方案。尽管如此,此类组件仍然服从这些条款。

TI 组件未获得用于 FDA Class III (或类似的生命攸关医疗设备)的授权许可,除非各方授权官员已经达成了专门管控此类使用的特别协议。

只有那些 TI 特别注明属于军用等级或“增强型塑料”的 TI 组件才是设计或专门用于军事/航空应用或环境的。购买者认可并同意,对并非指定面向军事或航空航天用途的 TI 组件进行军事或航空航天方面的应用,其风险由客户单独承担,并且由客户独立负责满足与此类使用相关的所有法律和法规要求。

TI 已明确指定符合 ISO/TS16949 要求的产品,这些产品主要用于汽车。在任何情况下,因使用非指定产品而无法达到 ISO/TS16949 要求, TI 不承担任何责任。

	产品		应用
数字音频	www.ti.com.cn/audio	通信与电信	www.ti.com.cn/telecom
放大器和线性器件	www.ti.com.cn/amplifiers	计算机及周边	www.ti.com.cn/computer
数据转换器	www.ti.com.cn/dataconverters	消费电子	www.ti.com.cn/consumer-apps
DLP® 产品	www.dlp.com	能源	www.ti.com.cn/energy
DSP - 数字信号处理器	www.ti.com.cn/dsp	工业应用	www.ti.com.cn/industrial
时钟和计时器	www.ti.com.cn/clockandtimers	医疗电子	www.ti.com.cn/medical
接口	www.ti.com.cn/interface	安防应用	www.ti.com.cn/security
逻辑	www.ti.com.cn/logic	汽车电子	www.ti.com.cn/automotive
电源管理	www.ti.com.cn/power	视频和影像	www.ti.com.cn/video
微控制器 (MCU)	www.ti.com.cn/microcontrollers		
RFID 系统	www.ti.com.cn/rfidsys		
OMAP应用处理器	www.ti.com/omap		
无线连通性	www.ti.com.cn/wirelessconnectivity	德州仪器在线技术支持社区	www.deyisupport.com

邮寄地址: 上海市浦东新区世纪大道1568号, 中建大厦32楼邮政编码: 200122
Copyright © 2015, 德州仪器半导体技术(上海)有限公司

PACKAGING INFORMATION

Orderable Device	Status (1)	Package Type	Package Drawing	Pins	Package Qty	Eco Plan (2)	Lead finish/ Ball material (6)	MSL Peak Temp (3)	Op Temp (°C)	Device Marking (4/5)	Samples
LDC1101DRCR	ACTIVE	VSON	DRC	10	3000	RoHS & Green	NIPDAU	Level-2-260C-1 YEAR	-40 to 125	L1101	Samples
LDC1101DRCT	ACTIVE	VSON	DRC	10	250	RoHS & Green	NIPDAU	Level-2-260C-1 YEAR	-40 to 125	L1101	Samples

(1) The marketing status values are defined as follows:

ACTIVE: Product device recommended for new designs.

LIFEBUY: TI has announced that the device will be discontinued, and a lifetime-buy period is in effect.

NRND: Not recommended for new designs. Device is in production to support existing customers, but TI does not recommend using this part in a new design.

PREVIEW: Device has been announced but is not in production. Samples may or may not be available.

OBSELETE: TI has discontinued the production of the device.

(2) **RoHS:** TI defines "RoHS" to mean semiconductor products that are compliant with the current EU RoHS requirements for all 10 RoHS substances, including the requirement that RoHS substance do not exceed 0.1% by weight in homogeneous materials. Where designed to be soldered at high temperatures, "RoHS" products are suitable for use in specified lead-free processes. TI may reference these types of products as "Pb-Free".

RoHS Exempt: TI defines "RoHS Exempt" to mean products that contain lead but are compliant with EU RoHS pursuant to a specific EU RoHS exemption.

Green: TI defines "Green" to mean the content of Chlorine (Cl) and Bromine (Br) based flame retardants meet JS709B low halogen requirements of <=1000ppm threshold. Antimony trioxide based flame retardants must also meet the <=1000ppm threshold requirement.

(3) MSL, Peak Temp. - The Moisture Sensitivity Level rating according to the JEDEC industry standard classifications, and peak solder temperature.

(4) There may be additional marking, which relates to the logo, the lot trace code information, or the environmental category on the device.

(5) Multiple Device Markings will be inside parentheses. Only one Device Marking contained in parentheses and separated by a "~" will appear on a device. If a line is indented then it is a continuation of the previous line and the two combined represent the entire Device Marking for that device.

(6) Lead finish/Ball material - Orderable Devices may have multiple material finish options. Finish options are separated by a vertical ruled line. Lead finish/Ball material values may wrap to two lines if the finish value exceeds the maximum column width.

Important Information and Disclaimer:The information provided on this page represents TI's knowledge and belief as of the date that it is provided. TI bases its knowledge and belief on information provided by third parties, and makes no representation or warranty as to the accuracy of such information. Efforts are underway to better integrate information from third parties. TI has taken and continues to take reasonable steps to provide representative and accurate information but may not have conducted destructive testing or chemical analysis on incoming materials and chemicals. TI and TI suppliers consider certain information to be proprietary, and thus CAS numbers and other limited information may not be available for release.

In no event shall TI's liability arising out of such information exceed the total purchase price of the TI part(s) at issue in this document sold by TI to Customer on an annual basis.

TAPE AND REEL INFORMATION



QUADRANT ASSIGNMENTS FOR PIN 1 ORIENTATION IN TAPE



*All dimensions are nominal

Device	Package Type	Package Drawing	Pins	SPQ	Reel Diameter (mm)	Reel Width W1 (mm)	A0 (mm)	B0 (mm)	K0 (mm)	P1 (mm)	W (mm)	Pin1 Quadrant
LDC1101DRCR	VSON	DRC	10	3000	330.0	12.4	3.3	3.3	1.1	8.0	12.0	Q2
LDC1101DRCT	VSON	DRC	10	250	180.0	12.4	3.3	3.3	1.1	8.0	12.0	Q2

TAPE AND REEL BOX DIMENSIONS

*All dimensions are nominal

Device	Package Type	Package Drawing	Pins	SPQ	Length (mm)	Width (mm)	Height (mm)
LDC1101DRCR	VSON	DRC	10	3000	367.0	367.0	35.0
LDC1101DRCT	VSON	DRC	10	250	210.0	185.0	35.0

GENERIC PACKAGE VIEW

DRC 10

VSON - 1 mm max height

3 x 3, 0.5 mm pitch

PLASTIC SMALL OUTLINE - NO LEAD

This image is a representation of the package family, actual package may vary.
Refer to the product data sheet for package details.

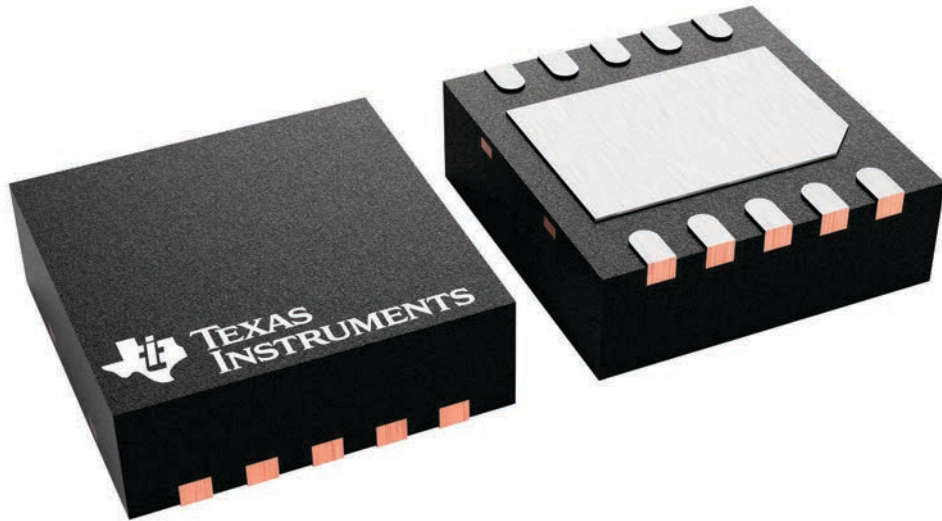

4226193/A

EXAMPLE BOARD LAYOUT

DRC0010J

VSON - 1 mm max height

PLASTIC SMALL OUTLINE - NO LEAD



LAND PATTERN EXAMPLE
EXPOSED METAL SHOWN
SCALE:20X



SOLDER MASK DETAILS

4218878/B 07/2018

NOTES: (continued)

4. This package is designed to be soldered to a thermal pad on the board. For more information, see Texas Instruments literature number SLUA271 (www.ti.com/lit/sluea271).
5. Vias are optional depending on application, refer to device data sheet. If any vias are implemented, refer to their locations shown on this view. It is recommended that vias under paste be filled, plugged or tented.

EXAMPLE STENCIL DESIGN

DRC0010J

VSON - 1 mm max height

PLASTIC SMALL OUTLINE - NO LEAD

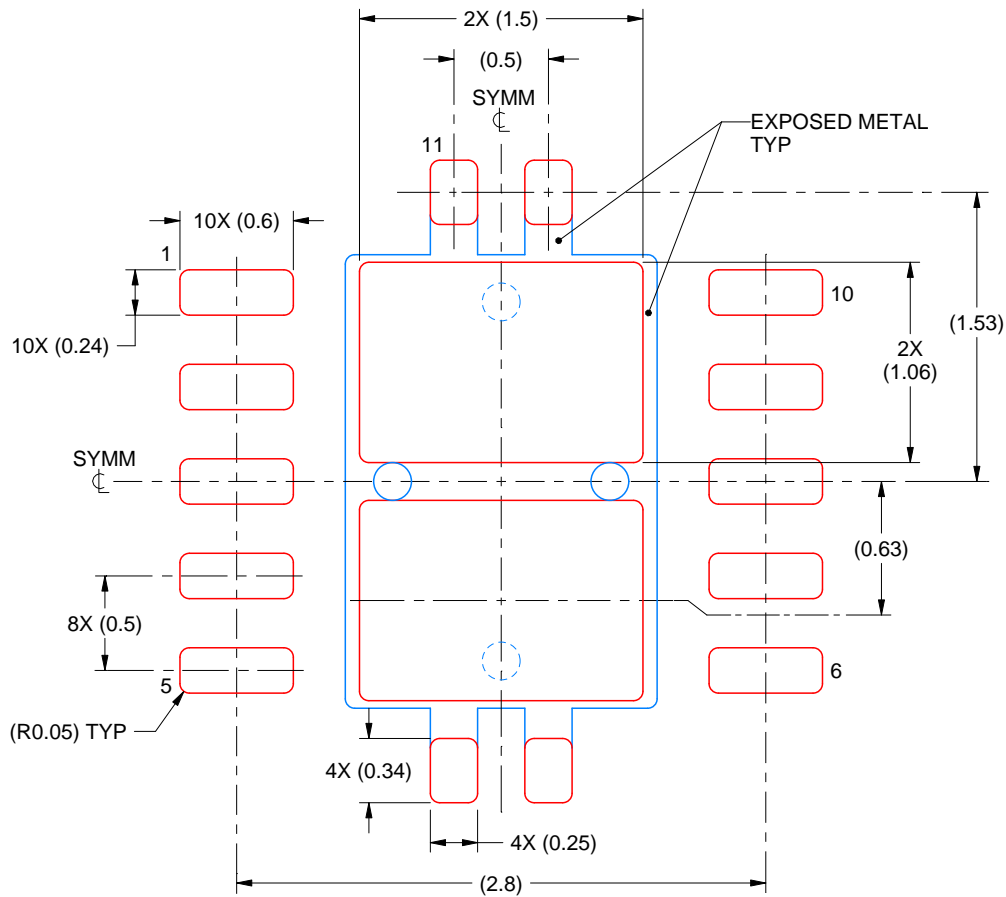

SOLDER PASTE EXAMPLE
BASED ON 0.125 mm THICK STENCIL

EXPOSED PAD 11:
80% PRINTED SOLDER COVERAGE BY AREA
SCALE:25X

4218878/B 07/2018

NOTES: (continued)

6. Laser cutting apertures with trapezoidal walls and rounded corners may offer better paste release. IPC-7525 may have alternate design recommendations.

重要声明和免责声明

TI 均以“原样”提供技术性 & 可靠性数据（包括数据表）、设计资源（包括参考设计）、应用或其他设计建议、网络工具、安全信息和其他资源，不保证其中不含任何瑕疵，且不做任何明示或暗示的担保，包括但不限于对适销性、适合某特定用途或不侵犯任何第三方知识产权的暗示担保。

所述资源可供专业开发人员应用 TI 产品进行设计使用。您将对以下行为独自承担全部责任：(1) 针对您的应用选择合适的 TI 产品；(2) 设计、验证并测试您的应用；(3) 确保您的应用满足相应标准以及任何其他安全、安保或其他要求。所述资源如有变更，恕不另行通知。TI 对您使用所述资源的授权仅限于开发资源所涉及 TI 产品的相关应用。除此之外不得复制或展示所述资源，也不提供其它 TI 或任何第三方的知识产权授权许可。如因使用所述资源而产生任何索赔、赔偿、成本、损失及债务等，TI 对此概不负责，并且您须赔偿由此对 TI 及其代表造成的损害。

TI 所提供产品均受 TI 的销售条款 (<http://www.ti.com.cn/zh-cn/legal/termsofsale.html>) 以及 [ti.com.cn](http://www.ti.com.cn) 上或随附 TI 产品提供的其他可适用条款的约束。TI 提供所述资源并不扩展或以其他方式更改 TI 针对 TI 产品所发布的可适用的担保范围或担保免责声明。

邮寄地址：上海市浦东新区世纪大道 1568 号中建大厦 32 楼，邮政编码：200122

Copyright © 2020 德州仪器半导体技术（上海）有限公司