

ISO732x 耐用 EMC 低功耗双通道数字隔离器

1 特性

- 信号传输速率: 25Mbps
- 输入时使用集成噪声滤波器
- 默认输出“高”和“低”选项
- 低功耗: 每通道的 I_{CC} 典型值 (1Mbps时):
 - ISO7320: 1.2mA (5V 电源供电时), 0.9mA (3.3V 电源供电时)
 - ISO7321: 1.7mA (5V 电源供电时), 1.2mA (3.3V 电源供电时)
- 低传播延迟: 典型值 33ns (5V 电源供电时)
- 3.3V 和 5V 电平转换
- 宽温度范围: -40°C 至 125°C
- 65KV/ μs 瞬态抗扰度, 典型值 (5V 电源供电时)
- 优异的电磁兼容性 (EMC)
 - 系统级静电放电 (ESD)、瞬态放电 (EFT) 以及抗浪涌保护
 - 低辐射
- 隔离栅寿命: > 25 年
- 可由 3.3V 和 5V 电压供电
- 窄体小尺寸集成电路 (SOIC)-8 封装
- 安全及管理批准:
 - 符合 DIN V VDE V 0884-10 和 DIN EN 61010-1 标准的 4242 V_{PK} 隔离中的 4242 V_{PK} 部分
 - 符合 UL 1577 标准且长达 1 分钟的 3000 V_{RMS} 隔离
 - CSA 组件接受通知 5A, IEC 60950-1、IEC 60601-1 和 IEC 61010-1 标准中 CSA 组件接受列表项的“(审批正在审理中)”
 - 通过 GB4943.1-2011 CQC 认证

2 应用

- 在下列应用中的光电耦合器替代产品:
 - 工业用 FieldBus
 - ProfiBus
 - ModBus
 - DeviceNet™ 数据总线
 - 伺服控制接口
 - 电机控制
 - 电源
 - 电池组

3 说明

ISO732x 可提供符合 UL 标准的长达 1 分钟且高达 3000 V_{RMS} 的电流隔离, 以及符合 VDE 标准的 4242 V_{PK} 隔离。这些器件具有两个隔离通道, 其逻辑输入和输出缓冲器由二氧化硅 (SiO_2) 绝缘隔栅分离开来。ISO7320 的两个通道方向相同, 而 ISO7321 的两个通道方向相反。如果出现输入功率或信号损失, 则后缀为“F”的器件默认输出“低”电平, 后缀没有“F”的器件则默认输出“高”电平。更多详细信息, 请参见 [器件功能模式](#)。与隔离电源配合使用, 这些器件可防止数据总线或者其它电路上的噪声电流进入本地接地并且干扰或损坏敏感电路。ISO732x 已针对恶劣环境集成了噪声滤波器, 在此类环境下, 器件的输入引脚上可能会出现短噪音脉冲。ISO732x 具有晶体管晶体管逻辑电路 (TTL) 输入阈值, 工作电压范围为 3V 到 5.5V。凭借创新的芯片设计和布线技术, ISO732x 的电磁兼容性得到了显著增强, 从而可确保提供系统级 ESD、EFT 和浪涌保护并符合辐射标准。

器件信息⁽¹⁾

器件型号	封装	封装尺寸 (标称值)
ISO7320C	SOIC (8)	4.90mm x 3.91mm
ISO7320FC		
ISO7321C		
ISO7321FC		

(1) 如需了解所有可用封装, 请见数据表末尾的可订购产品附录。

部分增加了脚注。

简化电路原理图

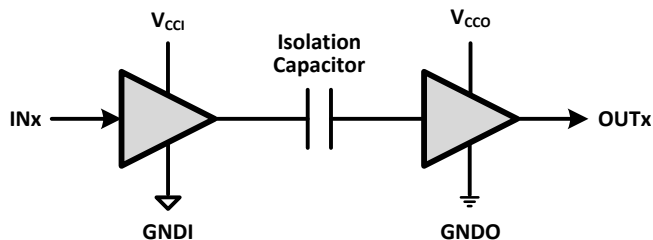

(1) V_{CCI} 和 $GNDI$ 分别是输入通道的电源和接地连接。

(2) V_{CCO} 和 $GNDO$ 分别是输出通道的电源和接地连接。



目录

1 特性	1	8.2 Functional Block Diagram	10
2 应用	1	8.3 Feature Description	11
3 说明	1	8.4 Device Functional Modes	14
4 修订历史记录	2	9 Applications and Implementation	15
5 Pin Configuration and Functions	3	9.1 Application Information	15
6 Specifications	4	9.2 Typical Application	15
6.1 Absolute Maximum Ratings	4	10 Power Supply Recommendations	17
6.2 ESD Ratings	4	11 Layout	17
6.3 Recommended Operating Conditions	4	11.1 PCB Material	17
6.4 Thermal Information	4	11.2 Layout Guidelines	17
6.5 Electrical Characteristics, 5 V	5	11.3 Layout Example	17
6.6 Electrical Characteristics, 3.3 V	5	12 器件和文档支持	18
6.7 Switching Characteristics, 5 V	6	12.1 相关链接	18
6.8 Switching Characteristics, 3.3 V	6	12.2 商标	18
6.9 Typical Characteristics	7	12.3 静电放电警告	18
7 Parameter Measurement Information	9	12.4 术语表	18
8 Detailed Description	10	13 机械、封装和可订购信息	18
8.1 Overview	10		

4 修订历史记录

Changes from Revision B (April 2015) to Revision C	Page
• 已添加“和 DINEN 61010-1 标准”至特性	1
• 已删除特性	1
• Changed From: V_{CC1} To: V_{CC1} in Figure 11	9
• Changed From: V_{CC1} To: V_{CC1} and From: V_{CC2} To: V_{CC0} in Figure 13	9
• Deleted IEC from the section title: <i>Insulation and Safety-Related Specifications for D-8 Package</i>	11
• Changed the CTI Test Conditions in <i>Insulation and Safety-Related Specifications for D-8 Package</i>	11
• Changed V_{ISO} Test Condition in the <i>Insulation Characteristics</i> table	12

Changes from Revision A (March 2015) to Revision B	Page
• 将器件状态从：产品预览改为：量产	1

Changes from Original (January 2015) to Revision A	Page
• 从仅首页更改为完整数据表。	1
• 将 V_{CC1} 更改为 V_{CC1} 、 V_{CC2} 更改为 V_{CC0} 、GND1 更改为 GND1、GND2 更改为 GND0，并在简化电路原理图	1

5 Pin Configuration and Functions

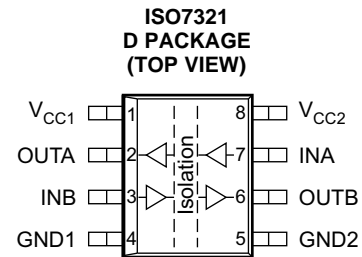
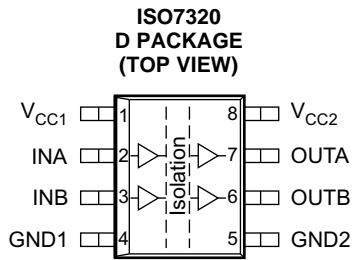

Pin Functions

NAME	PIN		I/O	DESCRIPTION
	ISO7320	ISO7321		
INA	2	7	I	Input, channel A
INB	3	3	I	Input, channel B
GND1	4	4	–	Ground connection for V_{CC1}
GND2	5	5	–	Ground connection for V_{CC2}
OUTA	7	2	O	Output, channel A
OUTB	6	6	O	Output, channel B
V_{CC1}	1	1	–	Power supply, V_{CC1}
V_{CC2}	8	8	–	Power supply, V_{CC2}

6 Specifications

6.1 Absolute Maximum Ratings⁽¹⁾

	MIN	MAX	UNIT
Supply voltage, V_{CC1} , V_{CC2} ⁽²⁾	-0.5	6	V
Voltage ⁽²⁾ INx, OUTx	-0.5	$V_{CC} + 0.5$ ⁽³⁾	V
Output current, I_O		±15	mA
Junction temperature, T_J		150	°C
Storage temperature, T_{stg}	-65	150	°C

- (1) Stresses beyond those listed under *absolute maximum ratings* may cause permanent damage to the device. These are stress ratings only and functional operation of the device at these or any other conditions beyond those indicated under *recommended operating conditions* is not implied. Exposure to absolute-maximum-rated conditions for extended periods may affect device reliability.
- (2) All voltage values are with respect to network ground terminal and are peak voltage values.
- (3) Maximum voltage must not exceed 6 V.

6.2 ESD Ratings

	VALUE	UNIT
V_{ESD}	Human body model (HBM), per ANSI/ESDA/JEDEC JS-001 ⁽¹⁾	±4000
	Charged device model (CDM), per JEDEC specification JESD22-C101 ⁽²⁾	±1500

- (1) JEDEC document JEP155 states that 500-V HBM allows safe manufacturing with a standard ESD control process.
- (2) JEDEC document JEP157 states that 250-V CDM allows safe manufacturing with a standard ESD control process.

6.3 Recommended Operating Conditions

	MIN	TYP	MAX	UNIT
V_{CC1} , V_{CC2} Supply voltage	3		5.5	V
I_{OH} High-level output current	-4			mA
I_{OL} Low-level output current			4	mA
V_{IH} High-level input voltage	2		5.5	V
V_{IL} Low-level input voltage	0		0.8	V
t_{ui} Input pulse duration	40			ns
$1 / t_{ui}$ Signaling rate	0		25	Mbps
T_J ⁽¹⁾ Junction temperature			136	°C
T_A Ambient temperature	-40	25	125	°C

- (1) To maintain the recommended operating conditions for T_J , see the [Thermal Information](#) table.

6.4 Thermal Information

THERMAL METRIC ⁽¹⁾		D PACKAGE	UNIT
		(8) PINS	
$R_{\theta JA}$	Junction-to-ambient thermal resistance	121	°C/W
$R_{\theta Jtop}$	Junction-to-case (top) thermal resistance	67.9	
$R_{\theta JB}$	Junction-to-board thermal resistance	61.6	
Ψ_{JT}	Junction-to-top characterization parameter	21.5	
Ψ_{JB}	Junction-to-board characterization parameter	61.1	
$R_{\theta Jcbot}$	Junction-to-case (bottom) thermal resistance	N/A	
P_D (ISO7320)	Maximum power dissipation by ISO7320	56	mW
P_{D1} (ISO7320)	Maximum power dissipation by side-1 of ISO7320	15	
P_{D2} (ISO7320)	Maximum power dissipation by side-2 of ISO7320	41	
P_D (ISO7321)	Maximum power dissipation by ISO7321	67	
P_{D1} (ISO7321)	Maximum power dissipation by side-1 of ISO7321	33.5	
P_{D2} (ISO7321)	Maximum power dissipation by side-2 of ISO7321	33.5	

- (1) For more information about traditional and new thermal metrics, see the IC Package Thermal Metrics application report, [SPRA953](#).

6.5 Electrical Characteristics, 5 V

V_{CC1} and V_{CC2} at 5 V \pm 10% (over recommended operating conditions unless otherwise noted)

PARAMETER		TEST CONDITIONS		MIN	TYP	MAX	UNIT
V_{OH}	High-level output voltage	$I_{OH} = -4$ mA; see Figure 11		$V_{CCO}^{(1)} - 0.5$	4.7		V
		$I_{OH} = -20$ μ A; see Figure 11		$V_{CCO}^{(1)} - 0.1$	5		
V_{OL}	Low-level output voltage	$I_{OL} = 4$ mA; see Figure 11			0.2	0.4	V
		$I_{OL} = 20$ μ A; see Figure 11			0	0.1	
$V_{I(HYS)}$	Input threshold voltage hysteresis				460		mV
I_{IH}	High-level input current	$I_N = V_{CC}$				10	μ A
I_{IL}	Low-level input current	$I_N = 0$ V		-10			μ A
CMTI	Common-mode transient immunity	$V_I = V_{CC}$ or 0 V; see Figure 13 .		25	65		kV/ μ s
SUPPLY CURRENT (All inputs switching with square wave clock signal for dynamic I_{CC} measurement)							
ISO7320							
I_{CC1}	Supply current for V_{CC1} and V_{CC2}	DC to 1 Mbps	DC Input: $V_I = V_{CC}$ or 0 V, AC Input: $C_L = 15$ pF		0.4	0.9	mA
I_{CC2}					2	3.2	
I_{CC1}		10 Mbps	$C_L = 15$ pF		0.8	1.4	
I_{CC2}					3.2	4.4	
I_{CC1}		25 Mbps	$C_L = 15$ pF		1.4	2.3	
I_{CC2}					4.9	6.8	
ISO7321							
I_{CC1}, I_{CC2}	Supply current for V_{CC1} and V_{CC2}	DC to 1 Mbps	DC Input: $V_I = V_{CC}$ or 0 V, AC Input: $C_L = 15$ pF		1.7	2.8	mA
I_{CC1}, I_{CC2}		10 Mbps	$C_L = 15$ pF		2.5	3.7	
I_{CC1}, I_{CC2}		25 Mbps	$C_L = 15$ pF		3.7	5.4	

(1) V_{CCO} is supply voltage, V_{CC1} or V_{CC2} , for the output channel being measured.

6.6 Electrical Characteristics, 3.3 V

V_{CC1} and V_{CC2} at 3.3 V \pm 10% (over recommended operating conditions unless otherwise noted)

PARAMETER		TEST CONDITIONS		MIN	TYP	MAX	UNIT
V_{OH}	High-level output voltage	$I_{OH} = -4$ mA; see Figure 11		$V_{CCO}^{(1)} - 0.5$	3		V
		$I_{OH} = -20$ μ A; see Figure 11		$V_{CCO}^{(1)} - 0.1$	3.3		
V_{OL}	Low-level output voltage	$I_{OL} = 4$ mA; see Figure 11			0.2	0.4	V
		$I_{OL} = 20$ μ A; see Figure 11			0	0.1	
$V_{I(HYS)}$	Input threshold voltage hysteresis				450		mV
I_{IH}	High-level input current	$I_N = V_{CC}$				10	μ A
I_{IL}	Low-level input current	$I_N = 0$ V		-10			μ A
CMTI	Common-mode transient immunity	$V_I = V_{CC}$ or 0 V; see Figure 13		25	50		kV/ μ s
SUPPLY CURRENT (All inputs switching with square wave clock signal for dynamic I_{CC} measurement)							
ISO7320							
I_{CC1}	Supply current for V_{CC1} and V_{CC2}	DC to 1 Mbps	DC Input: $V_I = V_{CC}$ or 0 V, AC Input: $C_L = 15$ pF		0.2	0.5	mA
I_{CC2}					1.5	2.5	
I_{CC1}		10 Mbps	$C_L = 15$ pF		0.5	0.8	
I_{CC2}					2.2	3.2	
I_{CC1}		25 Mbps	$C_L = 15$ pF		0.9	1.4	
I_{CC2}					3.3	4.7	
ISO7321							
I_{CC1}, I_{CC2}	Supply current for V_{CC1} and V_{CC2}	DC to 1 Mbps	DC Input: $V_I = V_{CC}$ or 0 V, AC Input: $C_L = 15$ pF		1.2	2	mA
I_{CC1}, I_{CC2}		10 Mbps	$C_L = 15$ pF		1.7	2.5	
I_{CC1}, I_{CC2}		25 Mbps	$C_L = 15$ pF		2.5	3.6	

(1) V_{CCO} is supply voltage, V_{CC1} or V_{CC2} , for the output channel being measured.

6.7 Switching Characteristics, 5 V

 V_{CC1} and V_{CC2} at 5 V \pm 10% (over recommended operating conditions unless otherwise noted)

PARAMETER		TEST CONDITIONS	MIN	TYP	MAX	UNIT
t_{PLH} , t_{PHL}	Propagation delay time	See Figure 11	20	33	57	ns
PWD ⁽¹⁾	Pulse width distortion $ t_{PHL} - t_{PLH} $				4	ns
$t_{sk(o)}$ ⁽²⁾	Channel-to-channel output skew time	ISO7320			2	ns
		ISO7321			17	
$t_{sk(pp)}$ ⁽³⁾	Part-to-part skew time				23	ns
t_r	Output signal rise time	See Figure 11		2.4		ns
t_f	Output signal fall time			2.1		ns
t_{fs}	Fail-safe output delay time from input power loss	See Figure 12		7.5		μ s

- (1) Also known as pulse skew.
- (2) $t_{sk(o)}$ is the skew between outputs of a single device with all driving inputs connected together and the outputs switching in the same direction while driving identical loads.
- (3) $t_{sk(pp)}$ is the magnitude of the difference in propagation delay times between any terminals of different devices switching in the same direction while operating at identical supply voltages, temperature, input signals and loads.

6.8 Switching Characteristics, 3.3 V

 V_{CC1} and V_{CC2} at 3.3 V \pm 10% (over recommended operating conditions unless otherwise noted)

PARAMETER		TEST CONDITIONS	MIN	TYP	MAX	UNIT3
t_{PLH} , t_{PHL}	Propagation delay time	See Figure 11	22	37	66	ns
PWD ⁽¹⁾	Pulse width distortion $ t_{PHL} - t_{PLH} $				3	ns
$t_{sk(o)}$ ⁽²⁾	Channel-to-channel output skew time	ISO7320			3	ns
		ISO7321			16	
$t_{sk(pp)}$ ⁽³⁾	Part-to-part skew time				28	ns
t_r	Output signal rise time	See Figure 11		3.1		ns
t_f	Output signal fall time			2.6		ns
t_{fs}	Fail-safe output delay time from input power loss	See Figure 12		7.4		μ s

- (1) Also known as pulse skew.
- (2) $t_{sk(o)}$ is the skew between outputs of a single device with all driving inputs connected together and the outputs switching in the same direction while driving identical loads.
- (3) $t_{sk(pp)}$ is the magnitude of the difference in propagation delay times between any terminals of different devices switching in the same direction while operating at identical supply voltages, temperature, input signals and loads.

6.9 Typical Characteristics

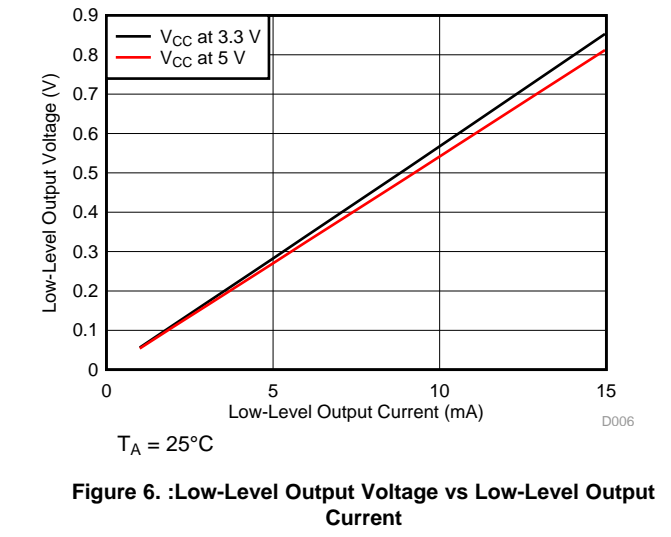
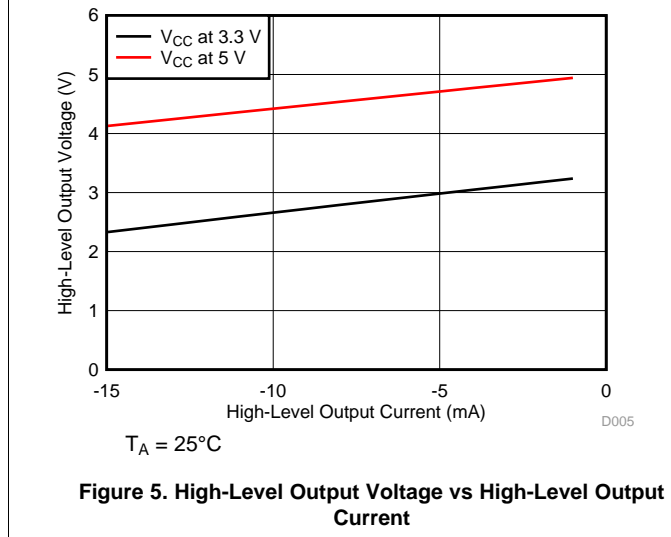
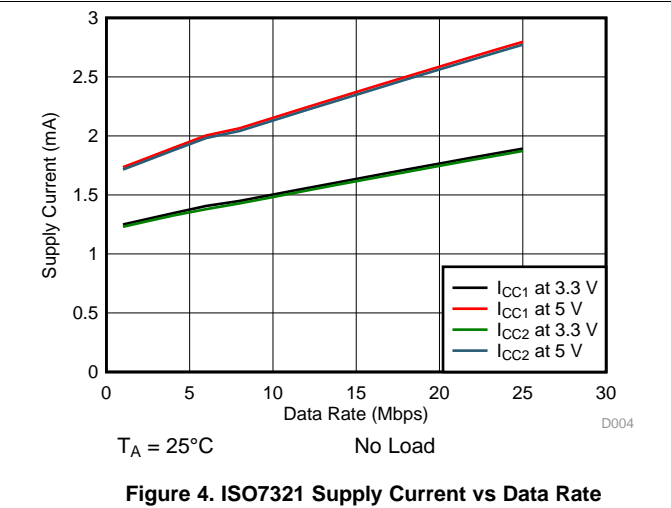
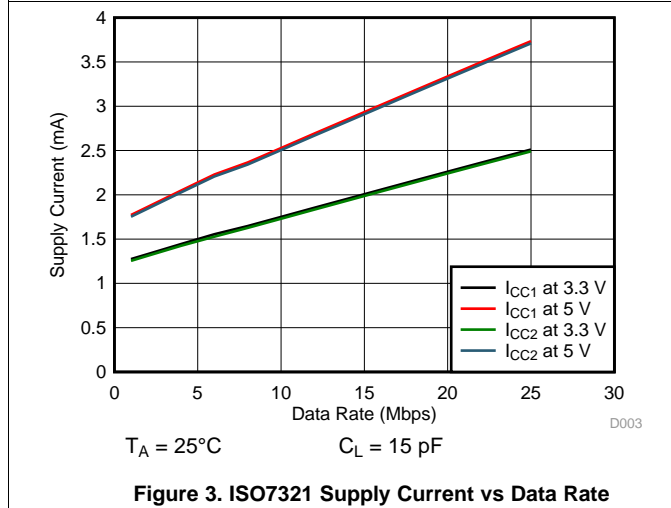
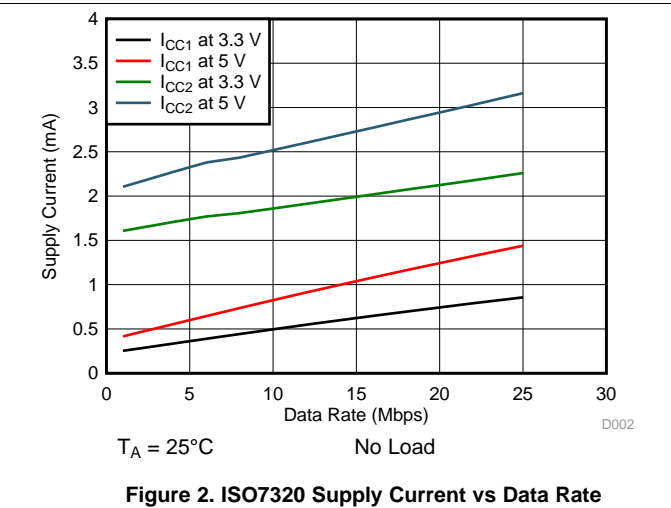
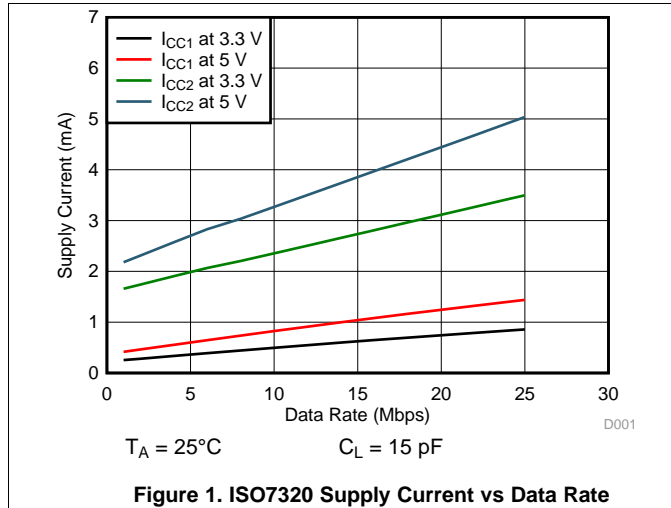

Typical Characteristics (continued)

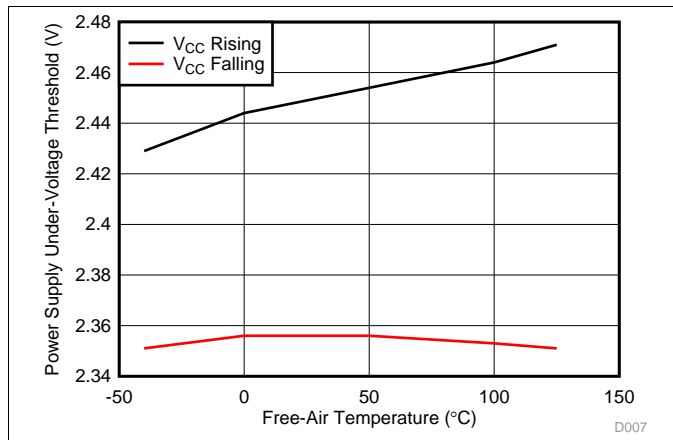

Figure 7. Power Supply Under Voltage Threshold vs Free-Air Temperature

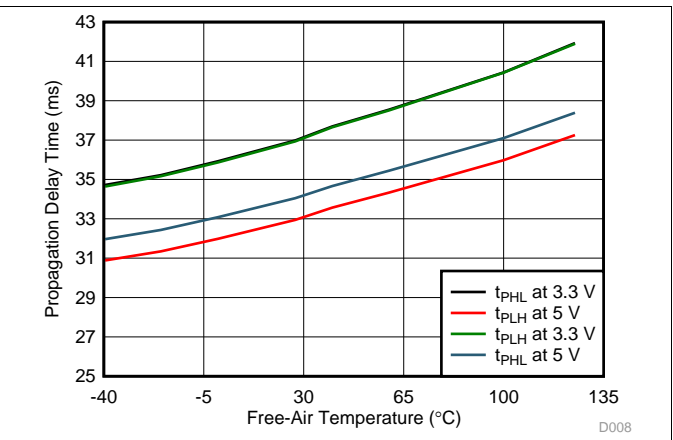

Figure 8. Propagation Delay Time vs Free-Air Temperature

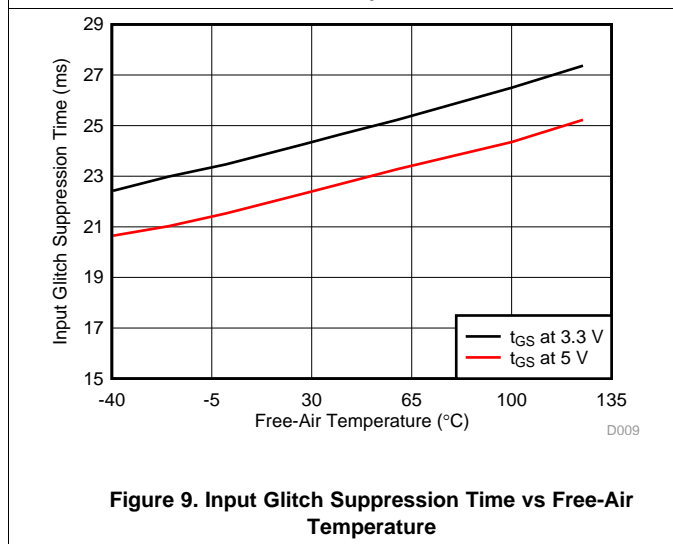

Figure 9. Input Glitch Suppression Time vs Free-Air Temperature

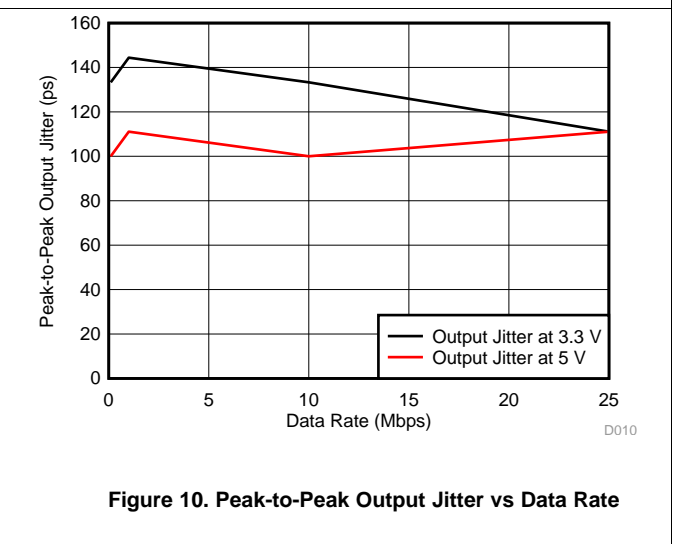
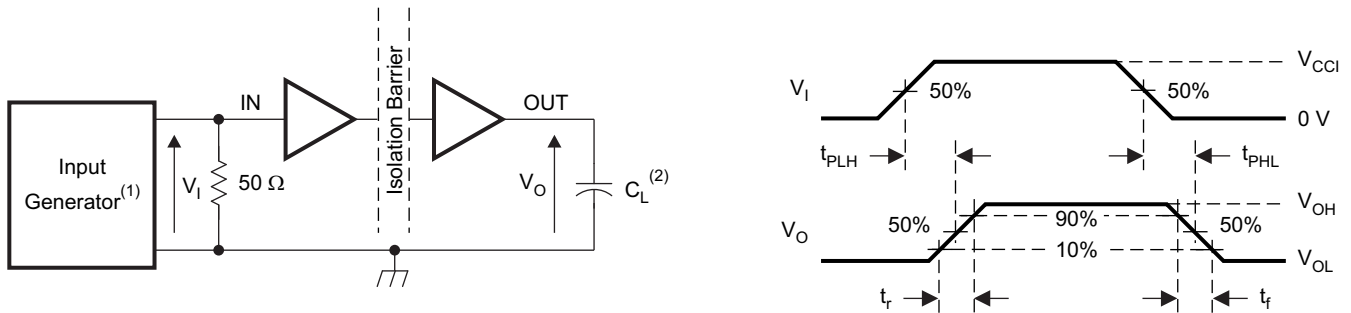

Figure 10. Peak-to-Peak Output Jitter vs Data Rate

7 Parameter Measurement Information



- (1) The input pulse is supplied by a generator having the following characteristics: PRR \leq 50 kHz, 50% duty cycle, $t_r \leq 3$ ns, $t_f \leq 3$ ns, $Z_O = 50 \Omega$. At the input, a 50- Ω resistor is required to terminate the Input Generator signal. It is not needed in actual application.
- (2) $C_L = 15$ pF and includes instrumentation and fixture capacitance within $\pm 20\%$.

Figure 11. Switching Characteristic Test Circuit and Voltage Waveforms

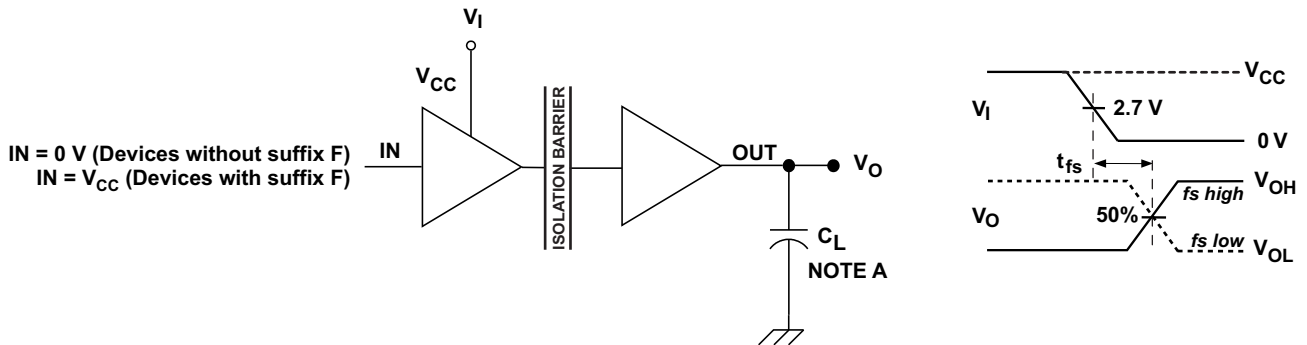

- A. $C_L = 15$ pF and includes instrumentation and fixture capacitance within $\pm 20\%$.

Figure 12. Fail-Safe Output Delay-Time Test Circuit and Voltage Waveforms

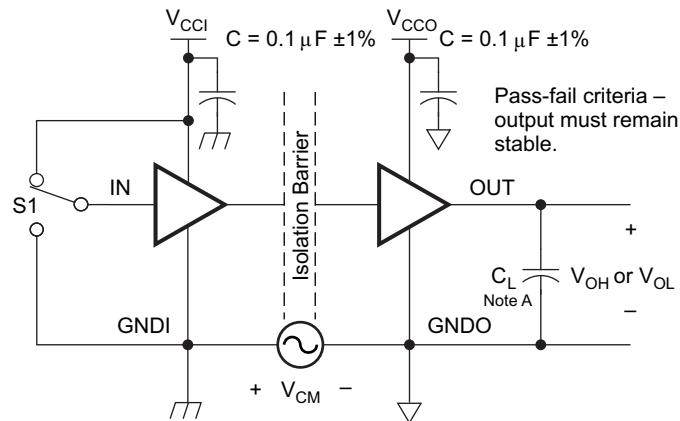

- (1) $C_L = 15$ pF and includes instrumentation and fixture capacitance within $\pm 20\%$.

Figure 13. Common-Mode Transient Immunity Test Circuit

8 Detailed Description

8.1 Overview

The isolator in [Figure 14](#) is based on a capacitive isolation barrier technique. The I/O channel of the device consists of two internal data channels, a high-frequency (HF) channel with a bandwidth from 100 kbps up to 25 Mbps, and a low-frequency (LF) channel covering the range from 100 kbps down to DC.

In principle, a single-ended input signal entering the HF channel is split into a differential signal via the inverter gate at the input. The following capacitor-resistor networks differentiate the signal into transient pulses, which then are converted into CMOS levels by a comparator. The transient pulses at the input of the comparator can be either above or below the common mode voltage V_{REF} depending on whether the input bit transitioned from 0 to 1 or 1 to 0. The comparator threshold is adjusted based on the expected bit transition. A decision logic (DCL) at the output of the HF channel comparator measures the durations between signal transients. If the duration between two consecutive transients exceeds a certain time limit, (as in the case of a low-frequency signal), the DCL forces the output-multiplexer to switch from the high-frequency to the low-frequency channel.

8.2 Functional Block Diagram

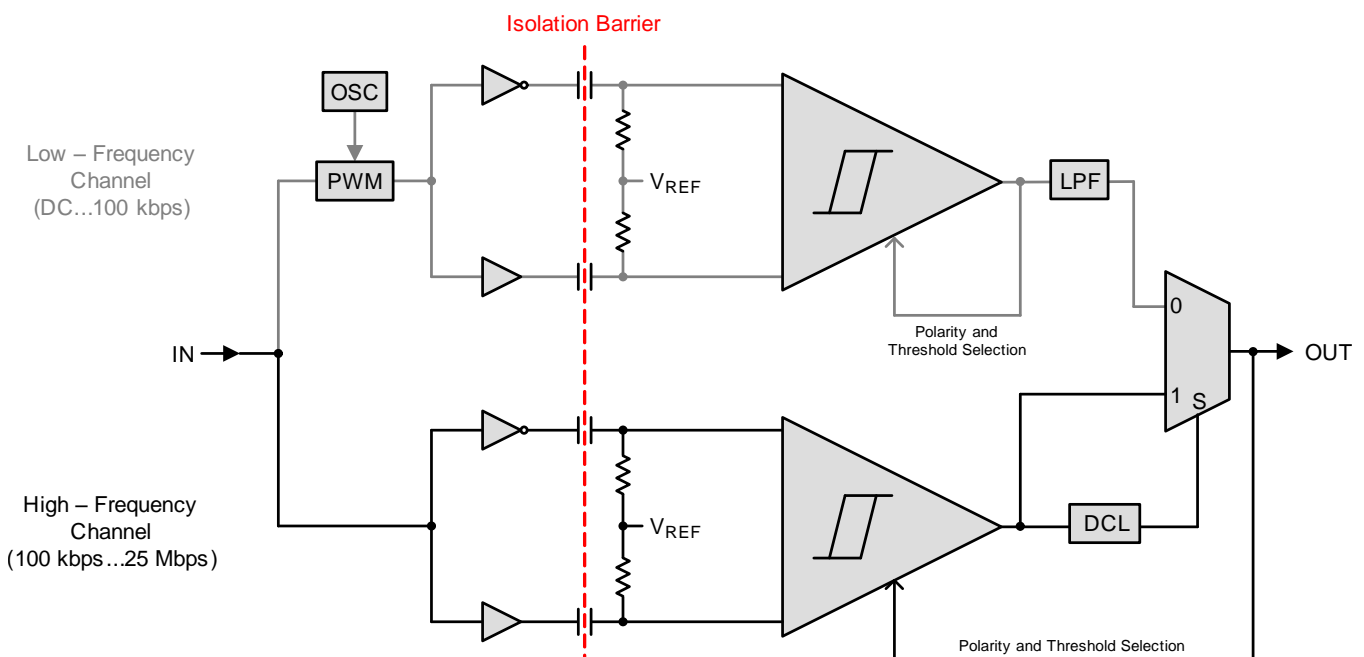

Figure 14. Conceptual Block Diagram of a Digital Capacitive Isolator

Because low-frequency input signals require the internal capacitors to assume prohibitively large values, these signals are pulse-width modulated (PWM) with the carrier frequency of an internal oscillator, thus creating a sufficiently high frequency, capable of passing the capacitive barrier. As the input is modulated, a low-pass filter (LPF) is needed to remove the high-frequency carrier from the actual data before passing it on to the output multiplexer.

8.3 Feature Description

PRODUCT	CHANNEL DIRECTION	RATED ISOLATION	MAX DATA RATE	DEFAULT OUTPUT
ISO7320C	Same	3000 V _{RMS} / 4242 V _{PK} ⁽¹⁾	25 Mbps	High
ISO7320FC				Low
ISO7321C	Opposite			High
ISO7321FC				Low

(1) See the [Regulatory Information](#) section for detailed Isolation Ratings

8.3.1 High Voltage Feature Description

8.3.1.1 Insulation and Safety-Related Specifications for D-8 Package

over recommended operating conditions (unless otherwise noted)

PARAMETER		TEST CONDITIONS	MIN	TYP	MAX	UNIT
L(I01)	Minimum air gap (clearance)	Shortest terminal-to-terminal distance through air	4			mm
L(I02)	Minimum external tracking (creepage)	Shortest terminal-to-terminal distance across the package surface	4			mm
CTI	Tracking resistance (comparative tracking index)	DIN EN 60112 (VDE 0303-11); IEC 60112	400			V
DTI	Minimum internal gap (internal clearance)	Distance through insulation	13			μm
R _{IO}	Isolation resistance, input to output ⁽¹⁾	V _{IO} = 500 V, T _A = 25°C	10 ¹²			Ω
		V _{IO} = 500 V, 100°C ≤ T _A ≤ 125°C	10 ¹¹			Ω
C _{IO}	Isolation capacitance, input to output ⁽¹⁾	V _{IO} = 0.4 sin (2πft), f = 1 MHz		1.5		pF
C _I	Input capacitance ⁽²⁾	V _I = V _{CC} /2 + 0.4 sin (2πft), f = 1 MHz, V _{CC} = 5 V		1.8		pF

(1) All pins on each side of the barrier tied together creating a two-terminal device.

(2) Measured from input pin to ground.

NOTE

Creepage and clearance requirements should be applied according to the specific equipment isolation standards of an application. Care should be taken to maintain the creepage and clearance distance of a board design to ensure that the mounting pads of the isolator on the printed-circuit board do not reduce this distance.

Creepage and clearance on a printed-circuit board become equal in certain cases. Techniques such as inserting grooves and/or ribs on a printed circuit board are used to help increase these specifications.

8.3.1.2 Insulation Characteristics

over recommended operating conditions (unless otherwise noted)

PARAMETER ⁽¹⁾		TEST CONDITIONS	SPECIFICATION	UNIT
V _{IOWM}	Maximum isolation working voltage		400	V _{RMS}
V _{IORM}	Maximum repetitive peak voltage per DIN V VDE V 0884-10		566	V _{PK}
V _{PR}	Input-to-output test voltage per DIN V VDE V 0884-10	After Input/Output safety test subgroup 2/3, V _{PR} = V _{IORM} × 1.2, t = 10 s, Partial discharge < 5 pC	680	V _{PK}
		Method a, After environmental tests subgroup 1, V _{PR} = V _{IORM} × 1.6, t = 10 s, Partial Discharge < 5 pC	906	
		Method b1, V _{PR} = V _{IORM} × 1.875, t = 1 s (100% Production test) Partial discharge < 5 pC	1062	
V _{IOTM}	Maximum transient overvoltage per DIN V VDE V 0884-10	V _{TEST} = V _{IOTM} t = 60 sec (qualification) t = 1 sec (100% production)	4242	V _{PK}
V _{IOSM}	Maximum surge isolation voltage per DIN V VDE V 0884-10	Test method per IEC 60065, 1.2/50 μs waveform, V _{TEST} = 1.3 × V _{IOSM} = 7800 V _{PK} (qualification)	6000	V _{PK}
V _{ISO}	Withstand isolation voltage per UL 1577	V _{TEST} = V _{ISO} = 3000 V _{RMS} , t = 60 sec (qualification); V _{TEST} = 1.2 × V _{ISO} = 3600 V _{RMS} , t = 1 sec (100% production)	3000	V _{RMS}
R _S	Insulation resistance	V _{IO} = 500 V at T _S	>10 ⁹	Ω
	Pollution degree		2	

(1) Climatic Classification 40/125/21

Table 1. IEC 60664-1 Ratings Table

PARAMETER	TEST CONDITIONS	SPECIFICATION
Basic isolation group	Material group	II
Installation classification	Rated mains voltage ≤ 150 V _{RMS}	I–IV
	Rated mains voltage ≤ 300 V _{RMS}	I–III

8.3.1.3 Regulatory Information

VDE	CSA	UL	CQC
Certified according to DIN V VDE V 0884-10 (VDE V 0884-10):2006-12	Approved under CSA Component Acceptance Notice 5A, IEC 60950-1, and IEC 61010-1	Recognized under UL 1577 Component Recognition Program	Certified according to GB4943.1-2011
Basic Insulation Maximum Transient Overvoltage, 4242 V _{PK} Maximum Surge Isolation Voltage, 6000 V _{PK} Maximum Repetitive Peak Voltage, 566 V _{PK}	400 V _{RMS} Basic Insulation and 200 V _{RMS} Reinforced Insulation working voltage per CSA 60950-1-07+A1+A2 and IEC 60950-1 2nd Ed.+A1+A2; 300 V _{RMS} Basic Insulation working voltage per CSA 61010-1-12 and IEC 61010-1 3rd Ed.	Single protection, 3000 V _{RMS} ⁽¹⁾	Basic Insulation, Altitude ≤ 5000 m, Tropical Climate, 250 V _{RMS} maximum working voltage
Certificate number: 40016131	Master contract number: 220991	File number: E181974	Certificate number: CQC15001121656

 (1) Production tested ≥ 3600 V_{RMS} for 1 second in accordance with UL 1577.

8.3.1.4 Safety Limiting Values

Safety limiting intends to prevent potential damage to the isolation barrier upon failure of input or output circuitry. A failure of the I/O can allow low resistance to ground or the supply and, without current limiting, dissipate sufficient power to overheat the die and damage the isolation barrier, potentially leading to secondary system failures.

PARAMETER	TEST CONDITIONS	MIN	TYP	MAX	UNIT
I _S	R _{θJA} = 121 °C/W, V _I = 5.5 V, T _J = 150°C, T _A = 25°C			188	mA
	R _{θJA} = 121 °C/W, V _I = 3.6 V, T _J = 150°C, T _A = 25°C			287	
T _S	Maximum case temperature			150	°C

The safety-limiting constraint is the absolute-maximum junction temperature specified in the *Absolut Maximun Ratings* table. The power dissipation and junction-to-air thermal impedance of the device installed in the application hardware determines the junction temperature. The assumed junction-to-air thermal resistance in the *Thermal Information* table is that of a device installed on a High-K Test Board for Leaded Surface-Mount Packages. The power is the recommended maximum input voltage times the current. The junction temperature is then the ambient temperature plus the power times the junction-to-air thermal resistance.

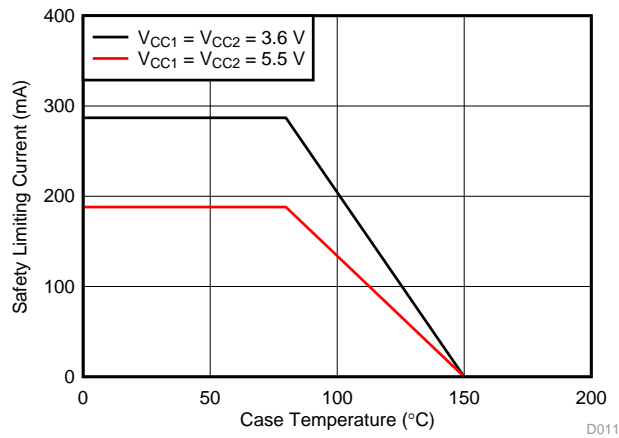

Figure 15. θ_{JC} Thermal Derating Curve per DIN V VDE V 0884-10

8.4 Device Functional Modes

Table 2. Function Table⁽¹⁾

V _{CCI}	V _{CCO}	INA, INB	OUTA, OUTB	
			ISO7320C, ISO7321C	ISO7320FC, ISO7321FC
PU	PU	H	H	H
		L	L	L
		Open	H ⁽²⁾	L ⁽³⁾
PD	PU	X	H ⁽²⁾	L ⁽³⁾
X	PD	X	Undetermined	Undetermined

- (1) V_{CCI} = Input-side V_{CC}; V_{CCO} = Output-side V_{CC}; PU = Powered up (V_{CC} ≥ 3 V); PD = Powered down (V_{CC} ≤ 2.1 V); X = Irrelevant; H = High level; L = Low level; Open = Not connected
- (2) In fail-safe condition, output defaults to high level
- (3) In fail-safe condition, output defaults to low level

8.4.1 Device I/O Schematics

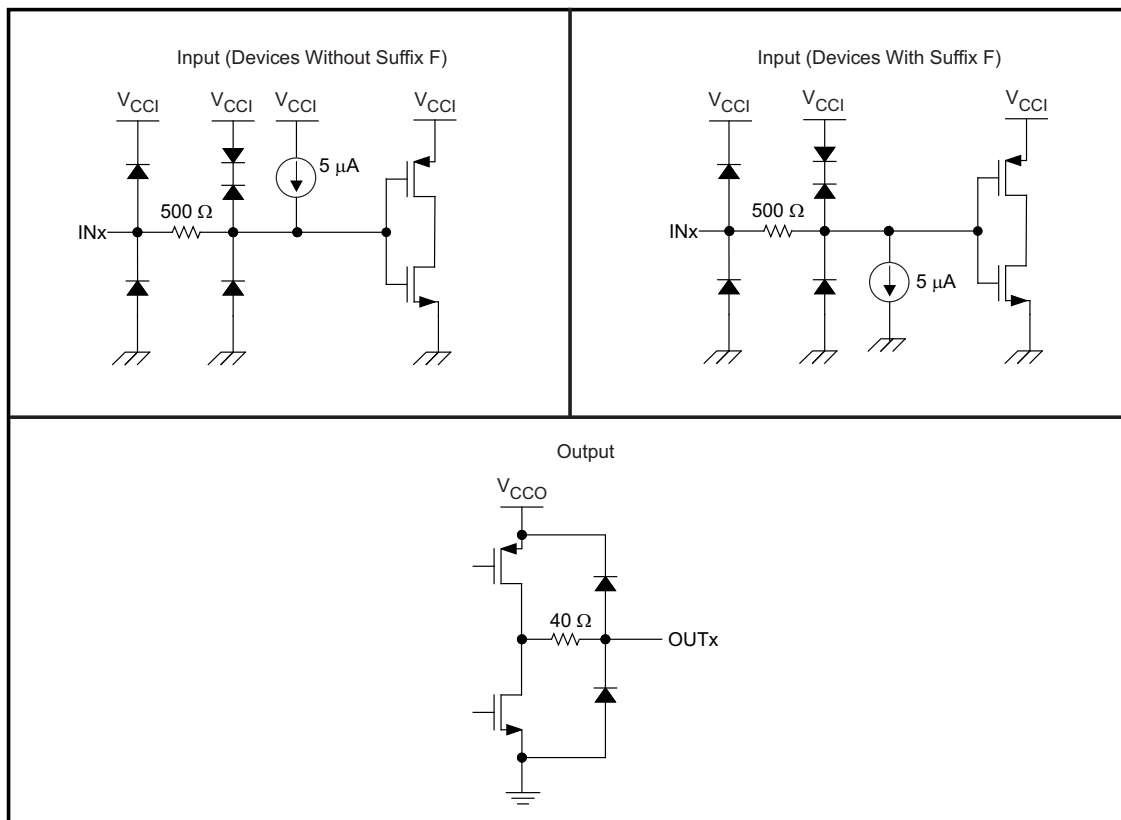

Figure 16. Device I/O Schematics

9 Applications and Implementation

NOTE

Information in the following applications sections is not part of the TI component specification, and TI does not warrant its accuracy or completeness. TI's customers are responsible for determining suitability of components for their purposes. Customers should validate and test their design implementation to confirm system functionality.

9.1 Application Information

ISO732x utilize single-ended TTL-logic switching technology. Its supply voltage range is from 3 V to 5.5 V for both supplies, V_{CC1} and V_{CC2} . When designing with digital isolators, it is important to keep in mind that due to the single-ended design structure, digital isolators do not conform to any specific interface standard and are only intended for isolating single-ended CMOS or TTL digital signal lines. The isolator is typically placed between the data controller (i.e. μC or UART), and a data converter or a line transceiver, regardless of the interface type or standard.

9.2 Typical Application

ISO7321 can be used with Texas Instruments' mixed signal micro-controller, digital-to-analog converter, transformer driver, and voltage regulator to create an isolated 4-20 mA current loop.

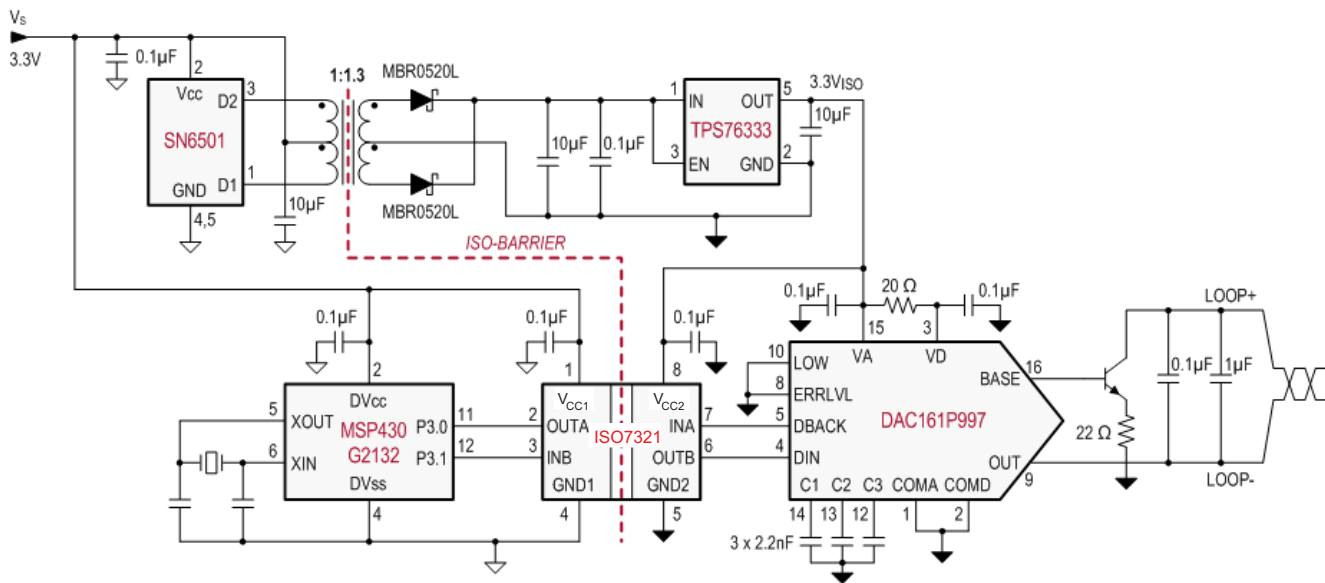

Figure 17. Typical ISO7321 Application Circuit

Typical Application (continued)

9.2.1 Design Requirements

9.2.1.1 Typical Supply Current Equations

ISO7320:

At $V_{CC1} = V_{CC2} = 5\text{ V}$

- $I_{CC1} = 0.3838 + (0.0431 \times f)$
- $I_{CC2} = 2.74567 + (0.08433 \times f) + (0.01 \times f \times C_L)$

At $V_{CC1} = V_{CC2} = 3.3\text{ V}$

- $I_{CC1} = 0.2394 + (0.02355 \times f)$
- $I_{CC2} = 2.10681 + (0.04374 \times f) + (0.007045 \times f \times C_L)$

ISO7321:

At $V_{CC1} = V_{CC2} = 5\text{ V}$

- I_{CC1} and $I_{CC2} = 1.5877 + (0.066 \times f) + (0.00123 \times f \times C_L)$

At $V_{CC1} = V_{CC2} = 3.3\text{ V}$

- I_{CC1} and $I_{CC2} = 1.187572 + (0.019399 \times f) + (0.0019029 \times f \times C_L)$

I_{CC1} and I_{CC2} are typical supply currents measured in mA, f is data rate measured in Mbps, C_L is the capacitive load measured in pF.

9.2.2 Detailed Design Procedure

9.2.2.1 Electromagnetic Compatibility (EMC) Considerations

Many applications in harsh industrial environment are sensitive to disturbances such as electrostatic discharge (ESD), electrical fast transient (EFT), surge and electromagnetic emissions. These electromagnetic disturbances are regulated by international standards such as IEC 61000-4-x and CISPR 22. Although system-level performance and reliability depends, to a large extent, on the application board design and layout, the ISO732x incorporate many chip-level design improvements for overall system robustness. Some of these improvements include:

- Robust ESD protection cells for input and output signal pins and inter-chip bond pads.
- Low-resistance connectivity of ESD cells to supply and ground pins.
- Enhanced performance of high voltage isolation capacitor for better tolerance of ESD, EFT and surge events.
- Bigger on-chip decoupling capacitors to bypass undesirable high energy signals through a low impedance path.
- PMOS and NMOS devices isolated from each other by using guard rings to avoid triggering of parasitic SCRs.
- Reduced common mode currents across the isolation barrier by ensuring purely differential internal operation.

9.2.3 Application Performance Curves

Typical eye diagrams of ISO732x below indicate low jitter and wide open eye at the maximum data rate of 25 Mbps.

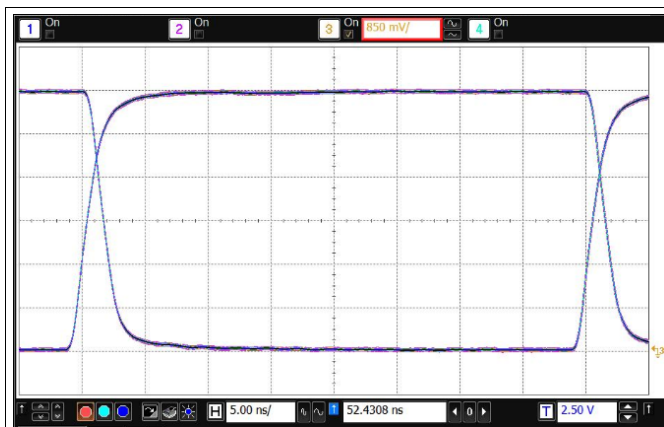

Figure 18. Eye Diagram at 25 Mbps, 5 V and 25°C

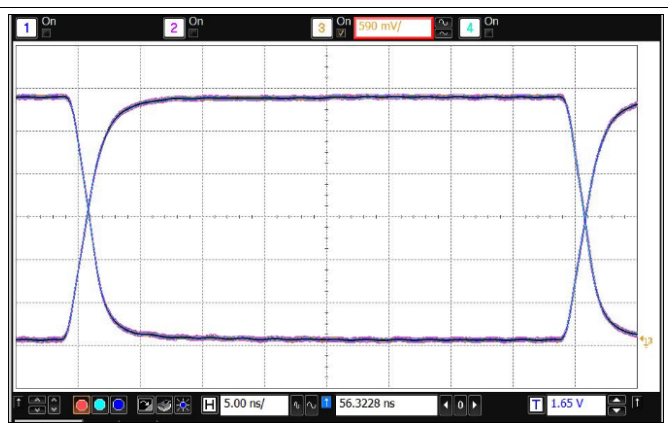

Figure 19. Eye Diagram at 25 Mbps, 3.3 V and 25°C

10 Power Supply Recommendations

To ensure reliable operation at all data rates and supply voltages, a 0.1 μF bypass capacitor is recommended at input and output supply pins (V_{CC1} & V_{CC2}). The capacitors should be placed as close to the supply pins as possible. If only a single primary-side power supply is available in an application, isolated power can be generated for the secondary-side with the help of a transformer driver such as Texas Instruments' [SN6501](#). For such applications, detailed power supply design and transformer selection recommendations are available in [SN6501](#) datasheet ([SLLSEA0](#)).

11 Layout

11.1 PCB Material

For digital circuit boards operating below 150 Mbps, (or rise and fall times higher than 1 ns), and trace lengths of up to 10 inches, use standard FR-4 epoxy-glass as PCB material. FR-4 (Flame Retardant 4) meets the requirements of Underwriters Laboratories UL94-V0, and is preferred over cheaper alternatives due to its lower dielectric losses at high frequencies, less moisture absorption, greater strength and stiffness, and its self-extinguishing flammability-characteristics.

11.2 Layout Guidelines

A minimum of four layers is required to accomplish a low EMI PCB design (see [Figure 20](#)). Layer stacking should be in the following order (top-to-bottom): high-speed signal layer, ground plane, power plane and low-frequency signal layer.

- Routing the high-speed traces on the top layer avoids the use of vias (and the introduction of their inductances) and allows for clean interconnects between the isolator and the transmitter and receiver circuits of the data link.
- Placing a solid ground plane next to the high-speed signal layer establishes controlled impedance for transmission line interconnects and provides an excellent low-inductance path for the return current flow.
- Placing the power plane next to the ground plane creates additional high-frequency bypass capacitance of approximately $100\text{pF}/\text{in}^2$.
- Routing the slower speed control signals on the bottom layer allows for greater flexibility as these signal links usually have margin to tolerate discontinuities such as vias.

If an additional supply voltage plane or signal layer is needed, add a second power / ground plane system to the stack to keep it symmetrical. This makes the stack mechanically stable and prevents it from warping. Also the power and ground plane of each power system can be placed closer together, thus increasing the high-frequency bypass capacitance significantly.

For detailed layout recommendations, see Application Note [SLLA284](#), *Digital Isolator Design Guide*.

11.3 Layout Example

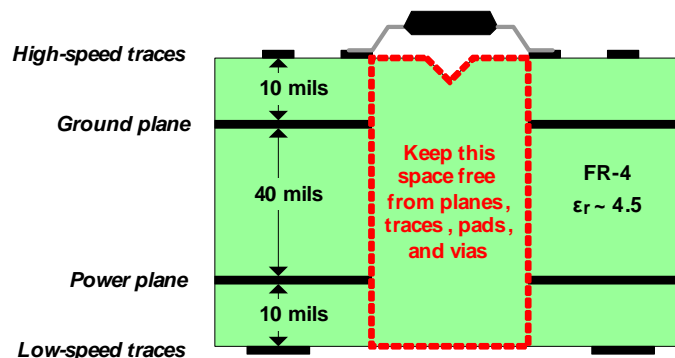

Figure 20. Recommended Layer Stack

12 器件和文档支持

12.1 相关链接

以下表格列出了快速访问链接。范围包括技术文档、支持与社区资源、工具和软件，并且可以快速访问样片或购买链接。

表 3. 相关链接

器件	产品文件夹	样片与购买	技术文档	工具与软件	支持与社区
ISO7320C	请单击此处	请单击此处	请单击此处	请单击此处	请单击此处
ISO7320FC	请单击此处	请单击此处	请单击此处	请单击此处	请单击此处
ISO7321C	请单击此处	请单击此处	请单击此处	请单击此处	请单击此处
ISO7321FC	请单击此处	请单击此处	请单击此处	请单击此处	请单击此处

12.2 商标

DeviceNet is a trademark of Texas Instruments.

All other trademarks are the property of their respective owners.

12.3 静电放电警告



这些装置包含有限的内置 ESD 保护。存储或装卸时，应将导线一起截短或将装置放置于导电泡棉中，以防止 MOS 门极遭受静电损伤。

12.4 术语表

[SLYZ022](#) — TI 术语表。

这份术语表列出并解释术语、首字母缩略词和定义。

《隔离相关术语》，[SLLA353](#)

13 机械、封装和可订购信息

以下页中包括机械、封装和可订购信息。这些信息是针对指定器件可提供的最新数据。这些数据会在无通知且不对本文档进行修订的情况下发生改变。欲获得该数据表的浏览器版本，请查阅左侧的导航栏。

PACKAGING INFORMATION

Orderable Device	Status (1)	Package Type	Package Drawing	Pins	Package Qty	Eco Plan (2)	Lead finish/ Ball material (6)	MSL Peak Temp (3)	Op Temp (°C)	Device Marking (4/5)	Samples
ISO7320CD	ACTIVE	SOIC	D	8	75	RoHS & Green	NIPDAU	Level-2-260C-1 YEAR	-40 to 125	7320C	Samples
ISO7320CDR	ACTIVE	SOIC	D	8	2500	RoHS & Green	NIPDAU	Level-2-260C-1 YEAR	-40 to 125	7320C	Samples
ISO7320FCD	ACTIVE	SOIC	D	8	75	RoHS & Green	NIPDAU	Level-2-260C-1 YEAR	-40 to 125	7320FC	Samples
ISO7320FCDR	ACTIVE	SOIC	D	8	2500	RoHS & Green	NIPDAU	Level-2-260C-1 YEAR	-40 to 125	7320FC	Samples
ISO7321CD	ACTIVE	SOIC	D	8	75	RoHS & Green	NIPDAU	Level-2-260C-1 YEAR	-40 to 125	7321C	Samples
ISO7321CDR	ACTIVE	SOIC	D	8	2500	RoHS & Green	NIPDAU	Level-2-260C-1 YEAR	-40 to 125	7321C	Samples
ISO7321FCD	ACTIVE	SOIC	D	8	75	RoHS & Green	NIPDAU	Level-2-260C-1 YEAR	-40 to 125	7321FC	Samples
ISO7321FCDR	ACTIVE	SOIC	D	8	2500	RoHS & Green	NIPDAU	Level-2-260C-1 YEAR	-40 to 125	7321FC	Samples

(1) The marketing status values are defined as follows:

ACTIVE: Product device recommended for new designs.

LIFEBUY: TI has announced that the device will be discontinued, and a lifetime-buy period is in effect.

NRND: Not recommended for new designs. Device is in production to support existing customers, but TI does not recommend using this part in a new design.

PREVIEW: Device has been announced but is not in production. Samples may or may not be available.

OBSELETE: TI has discontinued the production of the device.

(2) **RoHS:** TI defines "RoHS" to mean semiconductor products that are compliant with the current EU RoHS requirements for all 10 RoHS substances, including the requirement that RoHS substance do not exceed 0.1% by weight in homogeneous materials. Where designed to be soldered at high temperatures, "RoHS" products are suitable for use in specified lead-free processes. TI may reference these types of products as "Pb-Free".

RoHS Exempt: TI defines "RoHS Exempt" to mean products that contain lead but are compliant with EU RoHS pursuant to a specific EU RoHS exemption.

Green: TI defines "Green" to mean the content of Chlorine (Cl) and Bromine (Br) based flame retardants meet JS709B low halogen requirements of <=1000ppm threshold. Antimony trioxide based flame retardants must also meet the <=1000ppm threshold requirement.

(3) MSL, Peak Temp. - The Moisture Sensitivity Level rating according to the JEDEC industry standard classifications, and peak solder temperature.

(4) There may be additional marking, which relates to the logo, the lot trace code information, or the environmental category on the device.

(5) Multiple Device Markings will be inside parentheses. Only one Device Marking contained in parentheses and separated by a "~" will appear on a device. If a line is indented then it is a continuation of the previous line and the two combined represent the entire Device Marking for that device.

⁽⁶⁾ Lead finish/Ball material - Orderable Devices may have multiple material finish options. Finish options are separated by a vertical ruled line. Lead finish/Ball material values may wrap to two lines if the finish value exceeds the maximum column width.

Important Information and Disclaimer: The information provided on this page represents TI's knowledge and belief as of the date that it is provided. TI bases its knowledge and belief on information provided by third parties, and makes no representation or warranty as to the accuracy of such information. Efforts are underway to better integrate information from third parties. TI has taken and continues to take reasonable steps to provide representative and accurate information but may not have conducted destructive testing or chemical analysis on incoming materials and chemicals. TI and TI suppliers consider certain information to be proprietary, and thus CAS numbers and other limited information may not be available for release.

In no event shall TI's liability arising out of such information exceed the total purchase price of the TI part(s) at issue in this document sold by TI to Customer on an annual basis.

TAPE AND REEL INFORMATION

QUADRANT ASSIGNMENTS FOR PIN 1 ORIENTATION IN TAPE



*All dimensions are nominal

Device	Package Type	Package Drawing	Pins	SPQ	Reel Diameter (mm)	Reel Width W1 (mm)	A0 (mm)	B0 (mm)	K0 (mm)	P1 (mm)	W (mm)	Pin1 Quadrant
ISO7320CDR	SOIC	D	8	2500	330.0	12.4	6.4	5.2	2.1	8.0	12.0	Q1
ISO7320FCDR	SOIC	D	8	2500	330.0	12.4	6.4	5.2	2.1	8.0	12.0	Q1
ISO7321CDR	SOIC	D	8	2500	330.0	12.4	6.4	5.2	2.1	8.0	12.0	Q1
ISO7321FCDR	SOIC	D	8	2500	330.0	12.4	6.4	5.2	2.1	8.0	12.0	Q1

TAPE AND REEL BOX DIMENSIONS

*All dimensions are nominal

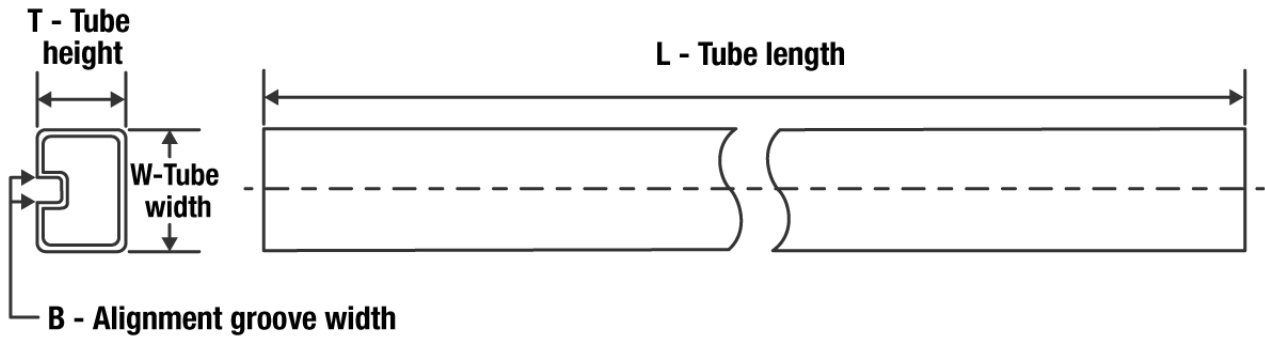
Device	Package Type	Package Drawing	Pins	SPQ	Length (mm)	Width (mm)	Height (mm)
ISO7320CDR	SOIC	D	8	2500	350.0	350.0	43.0
ISO7320FCDR	SOIC	D	8	2500	350.0	350.0	43.0
ISO7321CDR	SOIC	D	8	2500	350.0	350.0	43.0
ISO7321FCDR	SOIC	D	8	2500	350.0	350.0	43.0

TUBE

*All dimensions are nominal

Device	Package Name	Package Type	Pins	SPQ	L (mm)	W (mm)	T (μm)	B (mm)
ISO7320CD	D	SOIC	8	75	505.46	6.76	3810	4
ISO7320FCD	D	SOIC	8	75	505.46	6.76	3810	4
ISO7321CD	D	SOIC	8	75	505.46	6.76	3810	4
ISO7321FCD	D	SOIC	8	75	505.46	6.76	3810	4

重要声明和免责声明

TI“按原样”提供技术和可靠性数据（包括数据表）、设计资源（包括参考设计）、应用或其他设计建议、网络工具、安全信息和其他资源，不保证没有瑕疵且不做任何明示或暗示的担保，包括但不限于对适销性、某特定用途方面的适用性或不侵犯任何第三方知识产权的暗示担保。

这些资源可供使用 TI 产品进行设计的熟练开发人员使用。您将自行承担以下全部责任：(1) 针对您的应用选择合适的 TI 产品，(2) 设计、验证并测试您的应用，(3) 确保您的应用满足相应标准以及任何其他功能安全、信息安全、监管或其他要求。

这些资源如有变更，恕不另行通知。TI 授权您仅可将这些资源用于研发本资源所述的 TI 产品的应用。严禁对这些资源进行其他复制或展示。您无权使用任何其他 TI 知识产权或任何第三方知识产权。您应全额赔偿因在这些资源的使用中对 TI 及其代表造成的任何索赔、损害、成本、损失和债务，TI 对此概不负责。

TI 提供的产品受 [TI 的销售条款](#) 或 [ti.com](#) 上其他适用条款/TI 产品随附的其他适用条款的约束。TI 提供这些资源并不会扩展或以其他方式更改 TI 针对 TI 产品发布的适用的担保或担保免责声明。

TI 反对并拒绝您可能提出的任何其他或不同的条款。

邮寄地址：Texas Instruments, Post Office Box 655303, Dallas, Texas 75265

Copyright © 2022，德州仪器 (TI) 公司