

ISOS141-SEP Radiation Tolerant High-Speed Quad-Channel Digital Isolator

1 Features

- Radiation Tolerant
 - Total Ionizing Dose (TID) Characterized (ELDRS-Free) = 30 krad(Si)
 - TID RLAT/RHA = 30 krad(Si)
 - Single-Event Latch-up (SEL) Immune to LET = 43 MeV·cm²/mg at 125°C
 - Single-Event Dielectric Rupture (SEDR) Immune (43 MeV·cm²/mg) at 500 V_{DC}
- Space Enhanced Plastic (Space EP)
 - Meets NASA's ASTM E595 Outgassing Spec
 - Vendor Item Drawing (VID) [V62/21610](#)
 - Military Temp Range (-55°C to 125°C)
 - One Wafer Fabrication Site
 - One Assembly and Test Site
 - Gold Bond Wire, NiPdAu Lead Finish
 - Wafer Lot Traceability
 - Extended Product Life Cycle
 - Extended Product Change Notification
- 600 V_{RMS} continuous working voltage
- [Section 6.7](#):
 - DIN VDE V 0884-11:2017-01
 - UL 1577 component recognition program
- 100 Mbps data rate
- Wide supply range: 2.25 V to 5.5 V
- 2.25-V to 5.5-V level translation
- Default output *low*
- Low power consumption, 1.5 mA per channel typical at 1 Mbps
- Low propagation delay: 10.7 ns typical (5-V Supplies)
- Low channel-to-channel skew: 4 ns max (5-V Supplies)
- ±100 kV/μs typical CMTI
- System-level ESD, EFT, Surge, and Magnetic Immunity
- Small QSOP (DBQ-16) package

2 Applications

- Low Earth Orbit (LEO) Space Applications
- Signal Isolation (RS-422, RS-485, CAN, SPI)
- Gate Driver Isolation or Isolated Feedback for GaN DC-DC converters
- Space-Grade Isolated DC/DC Module
- Spacecraft Battery Management System (BMS)
- Satellite Propulsion Power Processing Unit (PPU)
- Launcher & Lander Systems
- Communications Payload
- Radar Imaging Payload

3 Description

The ISOS141-SEP radiation-tolerant device is a high-performance, quad-channel digital isolator in a small form factor 16-pin QSOP package. Each isolation channel has a logic input and output buffer separated by a double capacitive silicon dioxide (SiO₂) insulation barrier. This device supports low Earth orbit (LEO) space applications with its high data rate of 100 Mbps, low propagation delay of 10.7 ns, and tight channel-to-channel skew of 4 ns. The ISOS141-SEP device has three forward and one reverse-direction channels and if the input power or signal is lost, the default output is low. The enable pins can be used to put the respective outputs in high impedance for multi-master driving applications and to reduce power consumption.

The ISOS141-SEP provides high electromagnetic immunity and low emissions with low power consumption, while isolating CMOS or LVCMOS digital I/Os. The device has a high common-mode transient immunity of 100 kV/μs and can ease system-level ESD, EFT, surge, and simplify emissions compliance through its innovative chip design.

Device Information

PART NUMBER	PACKAGE	BODY SIZE (NOM)
ISOS141FDBQSEP 30 krad(Si) RLAT/RHA	16-lead QSOP (DBQ)	4.90 mm × 3.90 mm
ISOS141FDBQTSEP 30 krad(Si) RLAT/RHA		

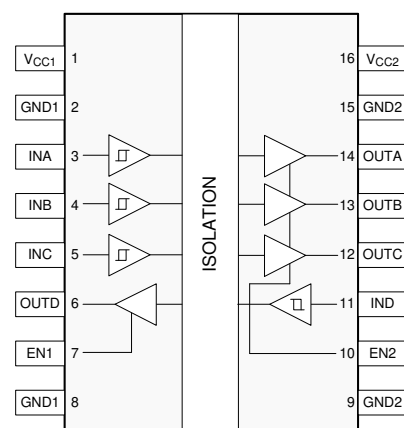

V_{CC1}=Input supply, V_{CC2}=Output supply
 GND1=Input ground, GND2=Output ground

Simplified Schematic



Table of Contents

1 Features	1	6.18 Insulation Characteristics Curves.....	15
2 Applications	1	6.19 Typical Characteristics.....	16
3 Description	1	7 Operating Life Deration	17
4 Revision History	2	8 Parameter Measurement Information	18
5 Pin Configuration and Functions	3	9 Detailed Description	20
6 Specifications	4	9.1 Overview.....	20
6.1 Absolute Maximum Ratings	4	9.2 Functional Block Diagram.....	20
6.2 ESD Ratings	4	9.3 Feature Description.....	21
6.3 Recommended Operating Conditions	5	9.4 Device Functional Modes.....	22
6.4 Thermal Information	6	10 Application and Implementation	23
6.5 Power Ratings	6	10.1 Application Information.....	23
6.6 Insulation Specifications	7	10.2 Typical Application.....	24
6.7 Safety-Related Certifications	8	11 Power Supply Recommendations	28
6.8 Safety Limiting Values	8	12 Layout	29
6.9 Electrical Characteristics—5-V Supply	9	12.1 Layout Guidelines.....	29
6.10 Supply Current Characteristics—5-V Supply	9	12.2 Layout Example.....	29
6.11 Electrical Characteristics—3.3-V Supply	10	13 Device and Documentation Support	30
6.12 Supply Current Characteristics—3.3-V Supply	10	13.1 Documentation Support.....	30
6.13 Electrical Characteristics—2.5-V Supply	11	13.2 Receiving Notification of Documentation Updates..	30
6.14 Supply Current Characteristics—2.5-V Supply	11	13.3 Community Resources.....	30
6.15 Switching Characteristics—5-V Supply	12	13.4 Trademarks.....	30
6.16 Switching Characteristics—3.3-V Supply	13	14 Mechanical, Packaging, and Orderable Information	31
6.17 Switching Characteristics—2.5-V Supply	14		

4 Revision History

NOTE: Page numbers for previous revisions may differ from page numbers in the current version.

DATE	REVISION	NOTES
May 2021	*	Initial release.

5 Pin Configuration and Functions

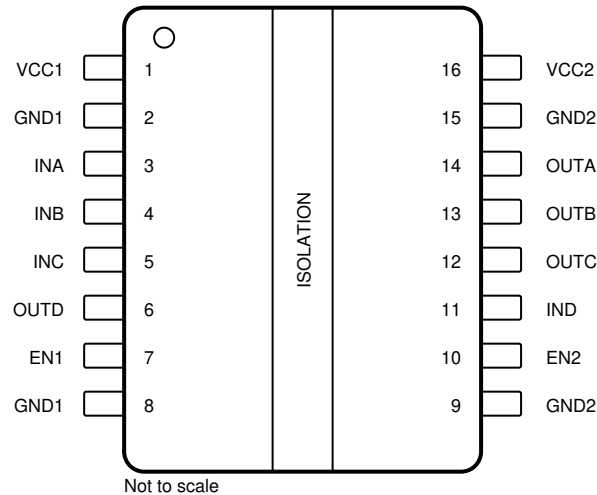

Figure 5-1. ISOS141-SEP DBQ Package 16-pin QSOP Top View

Table 5-1. Pin Functions

PIN		I/O	DESCRIPTION
NAME	Number		
EN1	7	I	Output enable 1. Output pins on side 1 are enabled when EN1 is high or open and in high-impedance state when EN1 is low.
EN2	10	I	Output enable 2. Output pins on side 2 are enabled when EN2 is high or open and in high-impedance state when EN2 is low.
GND1	2	—	Ground connection for V_{CC1}
	8		
GND2	9	—	Ground connection for V_{CC2}
	15		
INA	3	I	Input, channel A
INB	4	I	Input, channel B
INC	5	I	Input, channel C
IND	11	I	Input, channel D
OUTA	14	O	Output, channel A
OUTB	13	O	Output, channel B
OUTC	12	O	Output, channel C
OUTD	6	O	Output, channel D
V_{CC1}	1	—	Power supply, side 1
V_{CC2}	16	—	Power supply, side 2

6 Specifications

6.1 Absolute Maximum Ratings

See⁽¹⁾

		MIN	MAX	UNIT
Supply voltage ⁽²⁾	V_{CC1}, V_{CC2}	-0.5	6	V
Voltage at INx, OUTx, ENx	V	-0.5	$V_{CCX} + 0.5$ ⁽³⁾	V
Output current	I_o	-15	15	mA
Temperature	Operating junction temperature, T_J		150	°C
	Storage temperature, T_{stg}	-65	150	°C

- (1) Stresses beyond those listed under Absolute Maximum Ratings may cause permanent damage to the device. These are stress ratings only, which do not imply functional operation of the device at these or any other conditions beyond those indicated under Recommended Operating Conditions. Exposure to absolute-maximum-rated conditions for extended periods may affect device reliability.
- (2) All voltage values except differential I/O bus voltages are with respect to the local ground terminal (GND1 or GND2) and are peak voltage values
- (3) Maximum voltage must not exceed 6 V.

6.2 ESD Ratings

			VALUE	UNIT
$V_{(ESD)}$	Electrostatic discharge	Human body model (HBM), per ANSI/ESDA/JEDEC JS-001, all pins ⁽¹⁾	±6000	V
		Charged device model (CDM), per JEDEC specification JESD22-C101, all pins ⁽²⁾	±1500	
		Contact discharge per IEC 61000-4-2; Isolation barrier withstand test ^{(3) (4)}	±8000	

- (1) JEDEC document JEP155 states that 500-V HBM allows safe manufacturing with a standard ESD control process.
- (2) JEDEC document JEP157 states that 250-V CDM allows safe manufacturing with a standard ESD control process.
- (3) IEC ESD strike is applied across the barrier with all pins on each side tied together creating a two-terminal device.
- (4) Testing is carried out in air or oil to determine the intrinsic contact discharge capability of the device.

6.3 Recommended Operating Conditions

over operating free-air temperature range (unless otherwise noted)

		MIN	NOM	MAX	UNIT
V_{CC1}, V_{CC2} (1)	Supply Voltage	2.25		5.5	V
V_{CC} (UVLO+)	UVLO threshold when supply voltage is rising		2	2.25	V
V_{CC} (UVLO-)	UVLO threshold when supply voltage is falling	1.7	1.8		V
V_{hys} (UVLO)	Supply voltage UVLO hysteresis	100	200		mV
V_{IH}	High level Input voltage	$0.7 \times V_{CCI}$ (2)		V_{CCI}	V
V_{IL}	Low level Input voltage	0	$0.3 \times V_{CCI}$		V
I_{OH}	High level output current	$V_{CCO} = 5\text{ V}$ (2)		-4	mA
		$V_{CCO} = 3.3\text{ V}$		-2	mA
		$V_{CCO} = 2.5\text{ V}$		-1	mA
I_{OL}	Low level output current	$V_{CCO} = 5\text{ V}$		4	mA
		$V_{CCO} = 3.3\text{ V}$		2	mA
		$V_{CCO} = 2.5\text{ V}$		1	mA
DR	Data Rate	0		100	Mbps
T_A	Ambient temperature	-55	25	125	°C

(1) V_{CC1} and V_{CC2} can be set independent of one another

(2) $V_{CCI} = \text{Input-side } V_{CC}$; $V_{CCO} = \text{Output-side } V_{CC}$

6.4 Thermal Information

THERMAL METRIC ⁽¹⁾		ISOS141	UNIT
		DBQ (SOIC)	
		16 PINS	
$R_{\theta JA}$	Junction-to-ambient thermal resistance	109	°C/W
$R_{\theta JC(top)}$	Junction-to-case (top) thermal resistance	54.4	°C/W
$R_{\theta JB}$	Junction-to-board thermal resistance	51.9	°C/W
Ψ_{JT}	Junction-to-top characterization parameter	14.2	°C/W
Ψ_{JB}	Junction-to-board characterization parameter	51.4	°C/W
$R_{\theta JC(bot)}$	Junction-to-case (bottom) thermal resistance	—	°C/W

(1) For more information about traditional and new thermal metrics, see the [Semiconductor and IC Package Thermal Metrics application report](#).

6.5 Power Ratings

PARAMETER		TEST CONDITIONS	MIN	TYP	MAX	UNIT
ISOS141						
P_D	Maximum power dissipation (both sides)	$V_{CC1} = V_{CC2} = 5.5\text{ V}$, $T_J = 150^\circ\text{C}$, $C_L = 15\text{ pF}$, Input a 50-MHz 50% duty cycle square wave			200	mW
P_{D1}	Maximum power dissipation (side-1)				75	mW
P_{D2}	Maximum power dissipation (side-2)				125	mW

6.6 Insulation Specifications

PARAMETER		TEST CONDITIONS	VALUE	UNIT
			DBQ-16	
CLR	External clearance ⁽¹⁾	Shortest terminal-to-terminal distance through air	>3.7	mm
CPG	External creepage ⁽¹⁾	Shortest terminal-to-terminal distance across the package surface	>3.7	mm
DTI	Distance through the insulation	Minimum internal gap (internal clearance)	>21	um
CTI	Comparative tracking index	DIN EN 60112 (VDE 0303-11); IEC 60112	>600	V
	Material group	According to IEC 60664-1	I	
	Overvoltage category per IEC 60664-1	Rated mains voltage $\leq 300 V_{RMS}$	I-III	
DIN VDE V 0884-11:2017-01 ⁽²⁾				
V_{IORM}	Maximum repetitive peak isolation voltage	AC voltage (bipolar)	848	V_{PK}
V_{IOWM}	Maximum working isolation voltage	AC voltage; Time dependent dielectric breakdown (TDDB) Test See Figure 10-7	600	V_{RMS}
		DC voltage	848	V_{DC}
V_{IOTM}	Maximum transient isolation voltage	$V_{TEST} = V_{IOTM}$, $t = 60$ s (qualification); $V_{TEST} = 1.2 \times V_{IOTM}$, $t = 1$ s (100% production)	4242	V_{PK}
V_{IOSM}	Maximum surge isolation voltage ⁽³⁾	Test method per IEC 62368-1, 1.2/50 μ s waveform, $V_{TEST} = 1.3 \times V_{IOSM}$ (qualification)	4000	V_{PK}
q_{pd}	Apparent charge ⁽⁴⁾	Method a, After Input-output safety test subgroup 2/3, $V_{ini} = V_{IOTM}$, $t_{ini} = 60$ s; $V_{pd(m)} = 1.2 \times V_{IORM}$, $t_m = 10$ s	≤ 5	pC
		Method a, After environmental tests subgroup 1, $V_{ini} = V_{IOTM}$, $t_{ini} = 60$ s; $V_{pd(m)} = 1.2 \times V_{IORM}$, $t_m = 10$ s	≤ 5	
		Method b; At routine test (100% production) and preconditioning (type test) $V_{ini} = V_{IOTM}$, $t_{ini} = 1$ s; $V_{pd(m)} = 1.5 \times V_{IORM}$, $t_m = 1$ s	≤ 5	
C_{IO}	Barrier capacitance, input to output ⁽⁵⁾	$V_{IO} = 0.4 \times \sin(2\pi ft)$, $f = 1$ MHz	~ 1	pF
R_{IO}	Isolation resistance ⁽⁵⁾	$V_{IO} = 500$ V, $T_A = 25^\circ$ C	$>10^{12}$	Ω
		$V_{IO} = 500$ V, 100° C $\leq T_A \leq 125^\circ$ C	$>10^{11}$	
		$V_{IO} = 500$ V at $T_S = 150^\circ$ C	$>10^9$	
	Pollution degree		2	
	Climatic category		55/125/21	
UL 1577				
V_{ISO}	Maximum withstanding isolation voltage	$V_{TEST} = V_{ISO}$, $t = 60$ s (qualification), $V_{TEST} = 1.2 \times V_{ISO}$, $t = 1$ s (100% production)	3000	V_{RMS}

- (1) Creepage and clearance requirements should be applied according to the specific equipment isolation standards of an application. Care should be taken to maintain the creepage and clearance distance of a board design to ensure that the mounting pads of the isolator on the printed-circuit board do not reduce this distance. Creepage and clearance on a printed-circuit board become equal in certain cases. Techniques such as inserting grooves and/or ribs on a printed-circuit board are used to help increase these specifications.
- (2) This coupler is suitable for *basic electrical insulation* only within the safety ratings. Compliance with the safety ratings shall be ensured by means of suitable protective circuits.
- (3) Testing is carried out in air or oil to determine the intrinsic surge immunity of the isolation barrier.
- (4) Apparent charge is electrical discharge caused by a partial discharge (pd).
- (5) All pins on each side of the barrier tied together creating a two-terminal device.

6.7 Safety-Related Certifications

VDE	UL
Certifying according to DIN VDE V 0884-11:2017-01	Certifying according to UL 1577 Component Recognition Program
Maximum transient isolation voltage, 4242 V _{PK} (DBQ-16); Maximum repetitive peak isolation voltage, 848 V _{PK} (DBQ-16); Maximum surge isolation voltage, 4000 V _{PK} (DBQ-16)	Single protection, 3000 V _{RMS}
Basic certificate: planned	File number: planned

6.8 Safety Limiting Values

Safety limiting⁽¹⁾ intends to minimize potential damage to the isolation barrier upon failure of input or output circuitry.

PARAMETER	TEST CONDITIONS	MIN	TYP	MAX	UNIT
DBQ-16 PACKAGE					
I _S	Safety input, output, or supply current	R _{θJA} = 109°C/W, V _I = 5.5 V, T _J = 150°C, T _A = 25°C See Figure 6-1		209	mA
		R _{θJA} = 109°C/W, V _I = 3.6 V, T _J = 150°C, T _A = 25°C See Figure 6-1		319	
		R _{θJA} = 109°C/W, V _I = 2.75 V, T _J = 150°C, T _A = 25°C See Figure 6-1		417	
P _S	Safety input, output, or total power	R _{θJA} = 109°C/W, T _J = 150°C, T _A = 25°C See Figure 6-2		1147	mW
T _S	Maximum safety temperature			150	°C

- (1) The maximum safety temperature, T_S, has the same value as the maximum junction temperature, T_J, specified for the device. The I_S and P_S parameters represent the safety current and safety power respectively. The maximum limits of I_S and P_S should not be exceeded. These limits vary with the ambient temperature, T_A.
The junction-to-air thermal resistance, R_{θJA}, in the table is that of a device installed on a high-K test board for leaded surface-mount packages. Use these equations to calculate the value for each parameter:
T_J = T_A + R_{θJA} × P, where P is the power dissipated in the device.
T_{J(max)} = T_S = T_A + R_{θJA} × P_S, where T_{J(max)} is the maximum allowed junction temperature.
P_S = I_S × V_I, where V_I is the maximum input voltage.

6.9 Electrical Characteristics—5-V Supply

$V_{CC1} = V_{CC2} = 5\text{ V} \pm 10\%$ (over recommended operating conditions unless otherwise noted)

PARAMETER		TEST CONDITIONS	MIN	TYP	MAX	UNIT
V_{OH}	High-level output voltage	$I_{OH} = -4\text{ mA}$; See Figure 8-1	$V_{CCO} - 0.4$ ⁽¹⁾			V
V_{OL}	Low-level output voltage	$I_{OL} = 4\text{ mA}$; See Figure 8-1			0.4	V
$V_{IT+(IN)}$	Rising input switching threshold			$0.7 \times V_{CCI}$ ⁽¹⁾		V
$V_{IT-(IN)}$	Falling input switching threshold		$0.3 \times V_{CCI}$			V
$V_{I(HYS)}$	Input threshold voltage hysteresis		$0.1 \times V_{CCI}$			V
I_{IH}	High-level input current	$V_{IH} = V_{CCI}$ ⁽¹⁾ at INx or ENx			10	μA
I_{IL}	Low-level input current	$V_{IL} = 0\text{ V}$ at INx or ENx	-10			μA
CMTI	Common mode transient immunity	$V_I = V_{CC}$ or 0 V , $V_{CM} = 1200\text{ V}$; See Figure 8-4	85	100		kV/us
C_i	Input Capacitance ⁽²⁾	$V_I = V_{CC}/2 + 0.4 \times \sin(2\pi ft)$, $f = 2\text{ MHz}$, $V_{CC} = 5\text{ V}$		2		pF

(1) V_{CCI} = Input-side V_{CC} ; V_{CCO} = Output-side V_{CC}

(2) Measured from input pin to same side ground.

6.10 Supply Current Characteristics—5-V Supply

$V_{CC1} = V_{CC2} = 5\text{ V} \pm 10\%$ (over recommended operating conditions unless otherwise noted)

PARAMETER	TEST CONDITIONS	SUPPLY CURRENT	MIN	TYP	MAX	UNIT
ISOS141						
Supply current - Disable	$EN1 = EN2 = 0\text{ V}$; $V_I = 0\text{ V}$ (ISOS141)	I_{CC1}		1	1.5	mA
		I_{CC2}		0.8	1.1	
	$EN1 = EN2 = 0\text{ V}$; $V_I = V_{CCI}$ ⁽¹⁾ (ISOS141)	I_{CC1}		4.3	6.3	
		I_{CC2}		1.8	2.7	
Supply current - DC signal ⁽²⁾	$EN1 = EN2 = V_{CCI}$; $V_I = 0\text{ V}$ (ISOS141)	I_{CC1}		1.5	2.3	
		I_{CC2}		2	3	
	$EN1 = EN2 = V_{CCI}$; $V_I = V_{CCI}$ (ISOS141)	I_{CC1}		4.8	6.8	
		I_{CC2}		3.2	4.9	
Supply current - AC signal ⁽³⁾	All channels switching with square wave clock input; $C_L = 15\text{ pF}$	1 Mbps	I_{CC1}		3.2	4.6
			I_{CC2}		2.8	4.1
		10 Mbps	I_{CC1}		3.7	5.2
			I_{CC2}		4.2	5.7
		100 Mbps	I_{CC1}		8.6	11.3
			I_{CC2}		18	22

(1) V_{CCI} = Input-side V_{CC}

(2) Supply current valid for $ENx = V_{CCx}$ and $ENx = \text{open}$

(3) Supply current valid for $ENx = V_{CCx}$

6.11 Electrical Characteristics—3.3-V Supply

$V_{CC1} = V_{CC2} = 3.3\text{ V} \pm 10\%$ (over recommended operating conditions unless otherwise noted)

PARAMETER		TEST CONDITIONS	MIN	TYP	MAX	UNIT
V_{OH}	High-level output voltage	$I_{OH} = -2\text{mA}$; See Figure 8-1	$V_{CCO} - 0.3$ ⁽¹⁾			V
V_{OL}	Low-level output voltage	$I_{OL} = 2\text{mA}$; See Figure 8-1			0.3	V
$V_{IT+(IN)}$	Rising input switching threshold			$0.7 \times V_{CCI}$ ⁽¹⁾		V
$V_{IT-(IN)}$	Falling input switching threshold		$0.3 \times V_{CCI}$			V
$V_{I(HYS)}$	Input threshold voltage hysteresis		$0.1 \times V_{CCI}$			V
I_{IH}	High-level input current	$V_{IH} = V_{CCI}$ ⁽¹⁾ at INx or ENx			10	μA
I_{IL}	Low-level input current	$V_{IL} = 0\text{ V}$ at INx or ENx	-10			μA
CMTI	Common mode transient immunity	$V_I = V_{CC}$ or 0 V , $V_{CM} = 1200\text{ V}$; See Figure 8-4	85	100		kV/us
C_i	Input Capacitance ⁽²⁾	$V_I = V_{CC}/2 + 0.4 \times \sin(2\pi ft)$, $f = 1\text{ MHz}$, $V_{CC} = 5\text{ V}$		2		pF

- (1) $V_{CCI} =$ Input-side V_{CC} ; $V_{CCO} =$ Output-side V_{CC}
 (2) Measured from input pin to same side ground.

6.12 Supply Current Characteristics—3.3-V Supply

$V_{CC1} = V_{CC2} = 3.3\text{ V} \pm 10\%$ (over recommended operating conditions unless otherwise noted)

PARAMETER	TEST CONDITIONS	SUPPLY CURRENT	MIN	TYP	MAX	UNIT
ISOS141						
Supply current - Disable	$EN1 = EN2 = 0\text{ V}$; $V_I = 0\text{ V}$ (ISOS141)	I_{CC1}		1	1.5	mA
		I_{CC2}		0.8	1.1	
	$EN1 = EN2 = 0\text{ V}$; $V_I = V_{CC1}$ ⁽¹⁾ (ISOS141)	I_{CC1}		4.3	6.3	
		I_{CC2}		1.9	2.7	
Supply current - DC signal ⁽²⁾	$EN1 = EN2 = V_{CCI}$; $V_I = 0\text{ V}$ (ISOS141)	I_{CC1}		1.5	2.3	
		I_{CC2}		2	3	
	$EN1 = EN2 = V_{CCI}$; $V_I = V_{CCI}$ (ISOS141)	I_{CC1}		4.8	6.8	
		I_{CC2}		3.2	4.9	
Supply current - AC signal ⁽³⁾	All channels switching with square wave clock input; $C_L = 15\text{ pF}$	1 Mbps	I_{CC1}		3.2	4.6
			I_{CC2}		2.7	4.1
		10 Mbps	I_{CC1}		3.5	5
			I_{CC2}		3.7	5.2
		100 Mbps	I_{CC1}		6.8	9.3
			I_{CC2}		13.7	16.4

- (1) $V_{CCI} =$ Input-side V_{CC}
 (2) Supply current valid for $ENx = V_{CCx}$ and $ENx =$ open
 (3) Supply current valid for $ENx = V_{CCx}$

6.13 Electrical Characteristics—2.5-V Supply

$V_{CC1} = V_{CC2} = 2.5\text{ V} \pm 10\%$ (over recommended operating conditions unless otherwise noted)

PARAMETER		TEST CONDITIONS	MIN	TYP	MAX	UNIT
V_{OH}	High-level output voltage	$I_{OH} = -1\text{mA}$; See Figure 8-1	$V_{CCO} - 0.2$ ⁽¹⁾			V
V_{OL}	Low-level output voltage	$I_{OL} = 1\text{mA}$; See Figure 8-1			0.2	V
$V_{IT+(IN)}$	Rising input switching threshold			$0.7 \times V_{CCI}$ ⁽¹⁾		V
$V_{IT-(IN)}$	Falling input switching threshold		$0.3 \times V_{CCI}$			V
$V_{I(HYS)}$	Input threshold voltage hysteresis		$0.1 \times V_{CCI}$			V
I_{IH}	High-level input current	$V_{IH} = V_{CCI}$ ⁽¹⁾ at INx or ENx			10	μA
I_{IL}	Low-level input current	$V_{IL} = 0\text{ V}$ at INx or ENx	-10			μA
CMTI	Common mode transient immunity	$V_I = V_{CC}$ or 0 V, $V_{CM} = 1200\text{ V}$; See Figure 8-4	85	100		kV/us
C_i	Input Capacitance ⁽²⁾	$V_I = V_{CC}/2 + 0.4 \times \sin(2\pi ft)$, $f = 1\text{ MHz}$, $V_{CC} = 5\text{ V}$		2		pF

- (1) V_{CCI} = Input-side V_{CC} ; V_{CCO} = Output-side V_{CC}
(2) Measured from input pin to same side ground.

6.14 Supply Current Characteristics—2.5-V Supply

$V_{CC1} = V_{CC2} = 2.5\text{ V} \pm 10\%$ (over recommended operating conditions unless otherwise noted)

PARAMETER	TEST CONDITIONS	SUPPLY CURRENT	MIN	TYP	MAX	UNIT
ISOS141						
Supply current - Disable	$EN1 = EN2 = 0\text{ V}$; $V_I = 0\text{ V}$ (ISOS141)	I_{CC1}		1	1.5	mA
		I_{CC2}		0.8	1.1	
	$EN1 = EN2 = 0\text{ V}$; $V_I = V_{CC1}$ ⁽¹⁾ (ISOS141)	I_{CC1}		4.3	6.3	
		I_{CC2}		1.8	2.7	
Supply current - DC signal ⁽²⁾	$EN1 = EN2 = V_{CCI}$; $V_I = 0\text{ V}$ (ISOS141)	I_{CC1}		1.4	2.3	
		I_{CC2}		2	3	
	$EN1 = EN2 = V_{CCI}$; $V_I = V_{CCI}$ (ISOS141)	I_{CC1}		4.7	6.8	
		I_{CC2}		3.2	4.9	
Supply current - AC signal ⁽³⁾	All channels switching with square wave clock input; $C_L = 15\text{ pF}$	1 Mbps	I_{CC1}		3.1	4.6
			I_{CC2}		2.7	4
		10 Mbps	I_{CC1}		3.4	4.9
			I_{CC2}		3.5	4.9
		100 Mbps	I_{CC1}		5.6	8.3
			I_{CC2}		10.8	13.8

- (1) V_{CCI} = Input-side V_{CC}
(2) Supply current valid for $ENx = V_{CCx}$ and $ENx = \text{open}$
(3) Supply current valid for $ENx = V_{CCx}$

6.15 Switching Characteristics—5-V Supply

$V_{CC1} = V_{CC2} = 5\text{ V} \pm 10\%$ (over recommended operating conditions unless otherwise noted)

PARAMETER		TEST CONDITIONS	MIN	TYP	MAX	UNIT	
t_{PLH} , t_{PHL}	Propagation delay time	See Figure 8-1		10.7	16	ns	
PWD	Pulse width distortion ⁽¹⁾ $ t_{PHL} - t_{PLH} $				4.9	ns	
$t_{sk(o)}$	Channel-to-channel output skew time ⁽²⁾	Same-direction channels			4	ns	
$t_{sk(pp)}$	Part-to-part skew time ⁽³⁾				4.4	ns	
t_r	Output signal rise time	See Figure 8-1		2.4	3.9	ns	
t_f	Output signal fall time				2.4	3.9	ns
t_{PHZ}	Disable propagation delay, high-to-high impedance output	See Figure 8-2		9	20	ns	
t_{PLZ}	Disable propagation delay, low-to-high impedance output				9	20	ns
t_{PZH}	Enable propagation delay, high impedance-to-high output for ISOS141 with F suffix				3	8.5	μs
t_{PZL}	Enable propagation delay, high impedance-to-low output for ISOS141 with F suffix				7	20	ns
t_{DO}	Default output delay time from input power loss	Measured from the time VCC goes below 1.7V. See Figure 8-3		0.1	0.3	μs	
t_{ie}	Time interval error	$2^{16} - 1$ PRBS data at 100 Mbps		0.8		ns	

- (1) Also known as pulse skew.
- (2) $t_{sk(o)}$ is the skew between outputs of a single device with all driving inputs connected together and the outputs switching in the same direction while driving identical loads.
- (3) $t_{sk(pp)}$ is the magnitude of the difference in propagation delay times between any terminals of different devices switching in the same direction while operating at identical supply voltages, temperature, input signals and loads.

6.16 Switching Characteristics—3.3-V Supply

$V_{CC1} = V_{CC2} = 3.3\text{ V} \pm 10\%$ (over recommended operating conditions unless otherwise noted)

PARAMETER		TEST CONDITIONS	MIN	TYP	MAX	UNIT	
t_{PLH}, t_{PHL}	Propagation delay time	See Figure 8-1		11	16	ns	
PWD	Pulse width distortion ⁽¹⁾ $ t_{PHL} - t_{PLH} $				5	ns	
$t_{sk(o)}$	Channel-to-channel output skew time ⁽²⁾	Same-direction channels			4.1	ns	
$t_{sk(pp)}$	Part-to-part skew time ⁽³⁾				4.5	ns	
t_r	Output signal rise time	See Figure 8-1		1.3	3	ns	
t_f	Output signal fall time				1.3	3	ns
t_{PHZ}	Disable propagation delay, high-to-high impedance output	See Figure 8-2		17	30	ns	
t_{PLZ}	Disable propagation delay, low-to-high impedance output				17	30	ns
t_{PZH}	Enable propagation delay, high impedance-to-high output for ISOS141 with F suffix				3.2	8.5	μs
t_{PZL}	Enable propagation delay, high impedance-to-low output for ISOS141 with F suffix				17	30	ns
t_{DO}	Default output delay time from input power loss	Measured from the time VCC goes below 1.7V. See Figure 8-3		0.1	0.3	μs	
t_{ie}	Time interval error	$2^{16} - 1$ PRBS data at 100 Mbps		0.9		ns	

- (1) Also known as pulse skew.
- (2) $t_{sk(o)}$ is the skew between outputs of a single device with all driving inputs connected together and the outputs switching in the same direction while driving identical loads.
- (3) $t_{sk(pp)}$ is the magnitude of the difference in propagation delay times between any terminals of different devices switching in the same direction while operating at identical supply voltages, temperature, input signals and loads.

6.17 Switching Characteristics—2.5-V Supply

$V_{CC1} = V_{CC2} = 2.5\text{ V} \pm 10\%$ (over recommended operating conditions unless otherwise noted)

PARAMETER		TEST CONDITIONS	MIN	TYP	MAX	UNIT	
t_{PLH} , t_{PHL}	Propagation delay time	See Figure 8-1		12	18.5	ns	
PWD	Pulse width distortion ⁽¹⁾ $ t_{PHL} - t_{PLH} $				5.1	ns	
$t_{sk(o)}$	Channel-to-channel output skew time ⁽²⁾	Same-direction channels			4.1	ns	
$t_{sk(pp)}$	Part-to-part skew time ⁽³⁾				4.6	ns	
t_r	Output signal rise time	See Figure 8-1		1	3.5	ns	
t_f	Output signal fall time				1	3.5	ns
t_{PHZ}	Disable propagation delay, high-to-high impedance output	See Figure 8-2		22	40	ns	
t_{PLZ}	Disable propagation delay, low-to-high impedance output				22	40	ns
t_{PZH}	Enable propagation delay, high impedance-to-high output for ISOS141 with F suffix				3.3	8.5	μs
t_{PZL}	Enable propagation delay, high impedance-to-low output for ISOS141 with F suffix				18	40	ns
t_{DO}	Default output delay time from input power loss	Measured from the time VCC goes below 1.7V. See Figure 8-3		0.1	0.3	μs	
t_{ie}	Time interval error	$2^{16} - 1$ PRBS data at 100 Mbps		0.7		ns	

- (1) Also known as pulse skew.
- (2) $t_{sk(o)}$ is the skew between outputs of a single device with all driving inputs connected together and the outputs switching in the same direction while driving identical loads.
- (3) $t_{sk(pp)}$ is the magnitude of the difference in propagation delay times between any terminals of different devices switching in the same direction while operating at identical supply voltages, temperature, input signals and loads.

6.18 Insulation Characteristics Curves

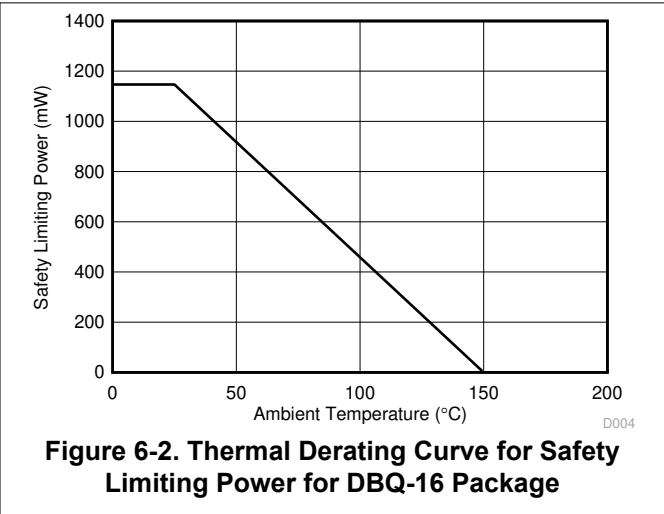
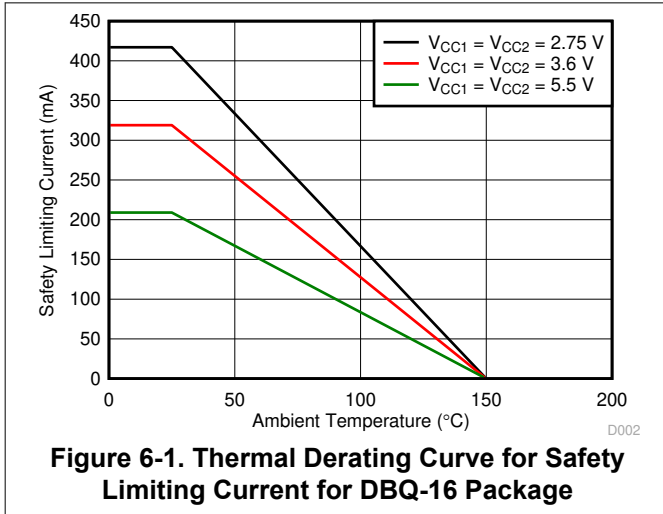

6.19 Typical Characteristics

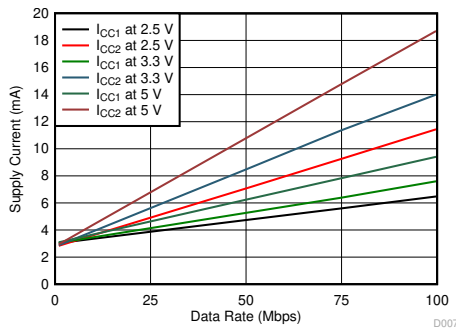

$T_A = 25^\circ\text{C}$ $C_L = 15\text{ pF}$

Figure 6-3. Supply Current vs Data Rate (With 15-pF Load)

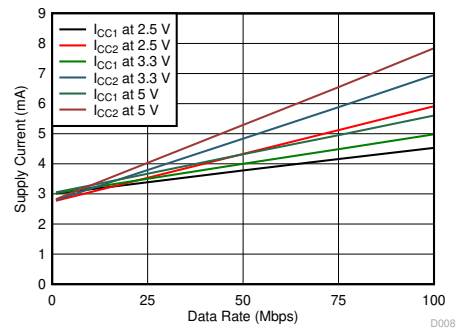

$T_A = 25^\circ\text{C}$ $C_L = \text{No Load}$

Figure 6-4. Supply Current vs Data Rate (With No Load)

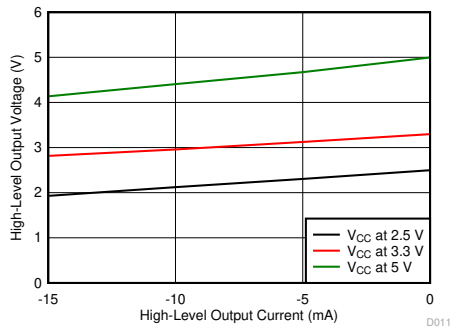

$T_A = 25^\circ\text{C}$

Figure 6-5. High-Level Output Voltage vs High-level Output Current

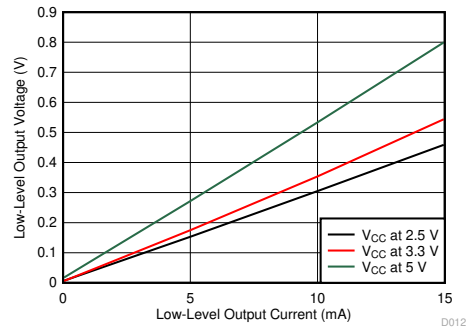

$T_A = 25^\circ\text{C}$

Figure 6-6. Low-Level Output Voltage vs Low-Level Output Current

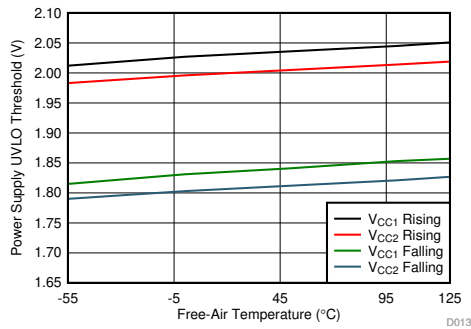

Figure 6-7. Power Supply Undervoltage Threshold vs Free-Air Temperature

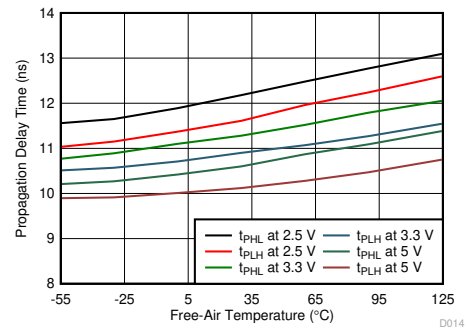
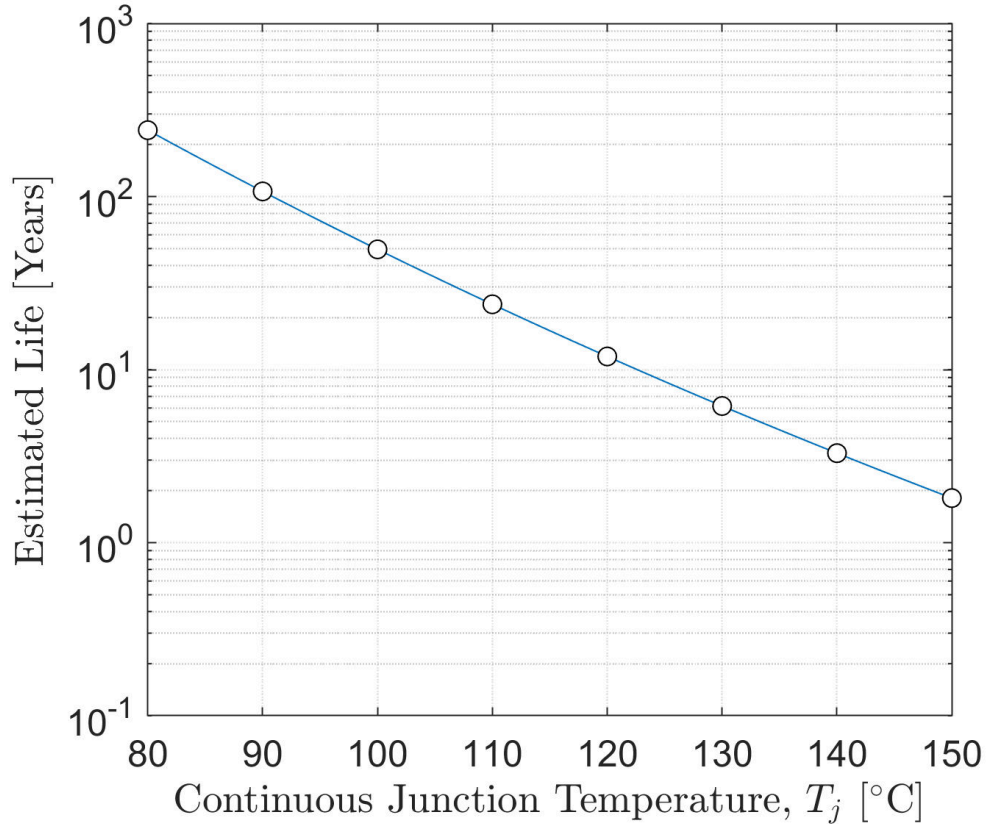

Figure 6-8. Propagation Delay Time vs Free-Air Temperature

7 Operating Life Deration

The information in this section is provided solely for your convenience and does not extend or modify the warranty provided under TI's standard terms and conditions for TI semiconductor products.



1. Silicon operating life design goal is 100000 power-on hours (POH) at 105 °C junction temperature (does not include package interconnect life).
2. The predicted operating lifetime versus junction temperature is based on reliability modeling using wirebond lifetime as the dominant failure mechanism affecting device wear out for the specific device process and design characteristics.

Wirebond Life Derating Curve

8 Parameter Measurement Information

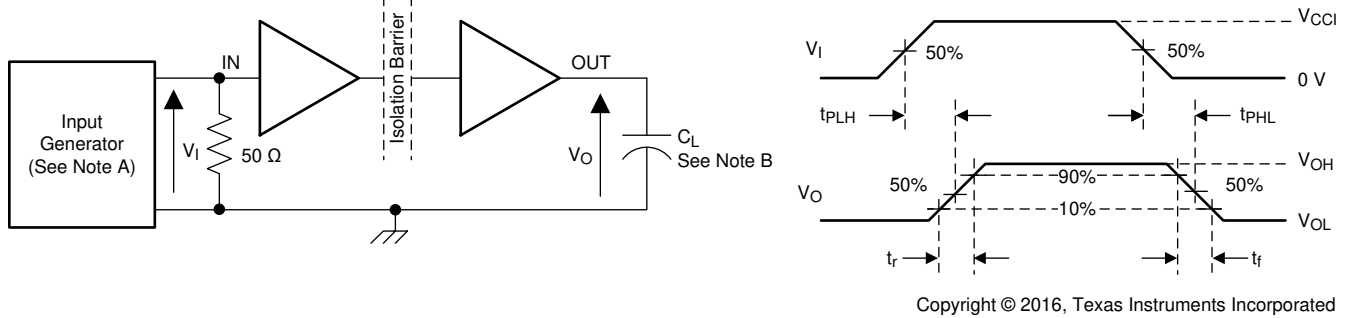

- A. The input pulse is supplied by a generator having the following characteristics: PRR \leq 50 kHz, 50% duty cycle, $t_r \leq$ 3 ns, $t_f \leq$ 3 ns, $Z_O =$ 50 Ω . At the input, 50 Ω resistor is required to terminate Input Generator signal. It is not needed in actual application.
- B. $C_L =$ 15 pF and includes instrumentation and fixture capacitance within $\pm 20\%$.

Figure 8-1. Switching Characteristics Test Circuit and Voltage Waveforms

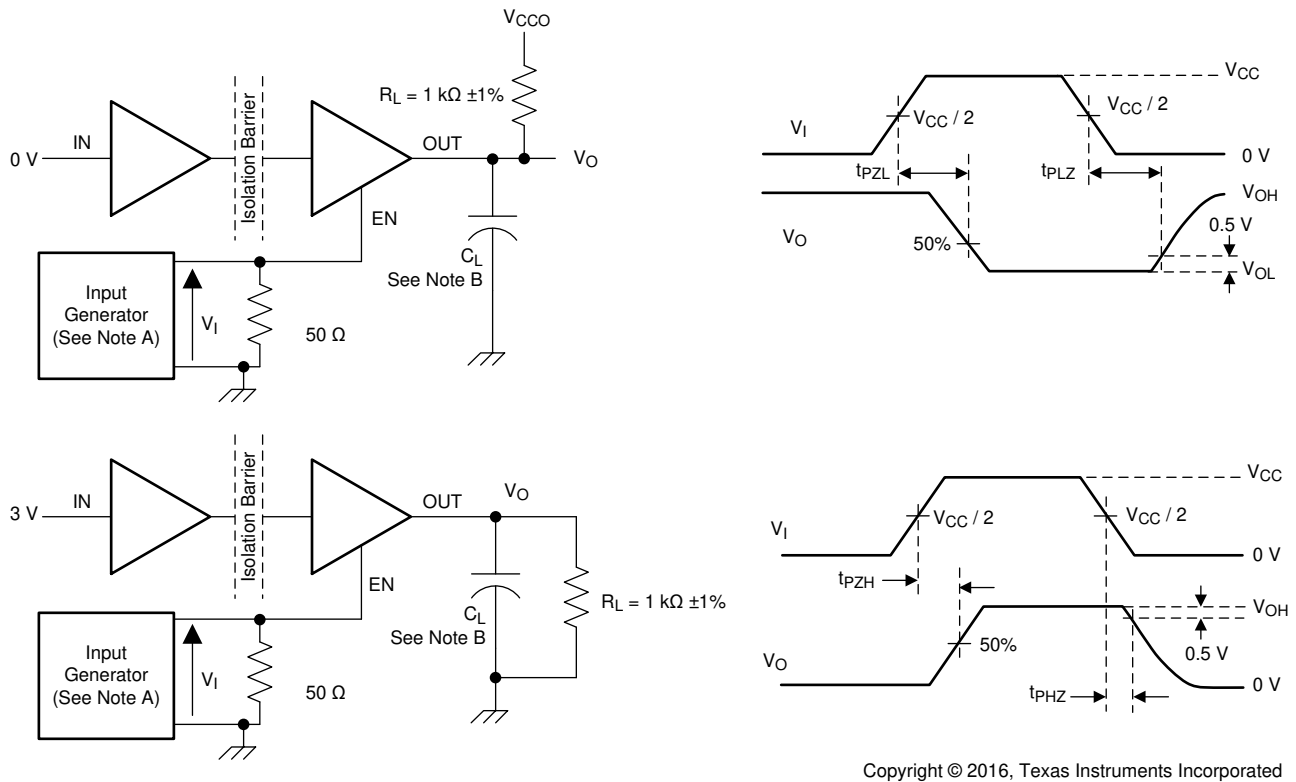

- A. The input pulse is supplied by a generator having the following characteristics: PRR \leq 10 kHz, 50% duty cycle, $t_r \leq$ 3 ns, $t_f \leq$ 3 ns, $Z_O =$ 50 Ω .
- B. $C_L =$ 15 pF and includes instrumentation and fixture capacitance within $\pm 20\%$.

Figure 8-2. Enable/Disable Propagation Delay Time Test Circuit and Waveform

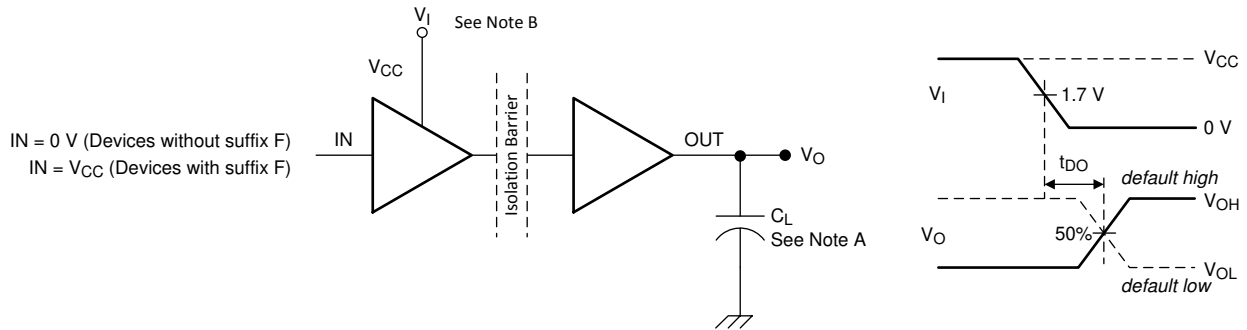

- A. $C_L = 15 \text{ pF}$ and includes instrumentation and fixture capacitance within $\pm 20\%$.
- B. Power Supply Ramp Rate = 10 mV/ns

Figure 8-3. Default Output Delay Time Test Circuit and Voltage Waveforms

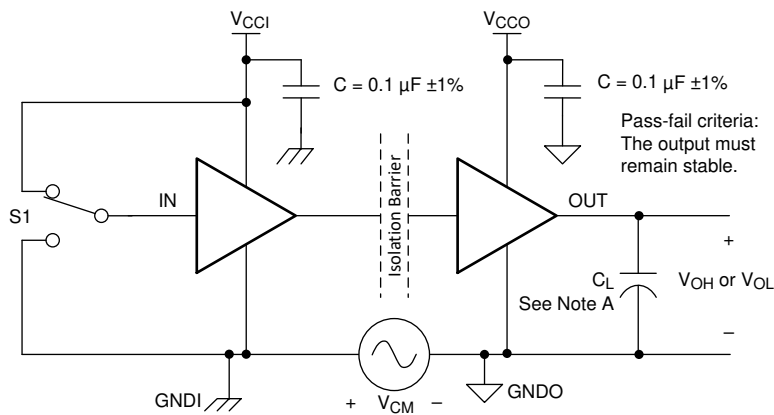

- A. $C_L = 15 \text{ pF}$ and includes instrumentation and fixture capacitance within $\pm 20\%$.

Figure 8-4. Common-Mode Transient Immunity Test Circuit

9 Detailed Description

9.1 Overview

The ISOS141-SEP has an ON-OFF keying (OOK) modulation scheme to transmit the digital data across a silicon dioxide based isolation barrier. The transmitter sends a high frequency carrier across the barrier to represent one digital state and sends no signal to represent the other digital state. The receiver demodulates the signal after advanced signal conditioning and produces the output through a buffer stage. If the ENx pin is low then the output goes to high impedance. The ISOS141-SEP device also incorporates advanced circuit techniques to maximize the CMTI performance and minimize the radiated emissions due to the high frequency carrier and IO buffer switching. The conceptual block diagram of a digital capacitive isolator, [Figure 9-1](#), shows a functional block diagram of a typical channel.

9.2 Functional Block Diagram

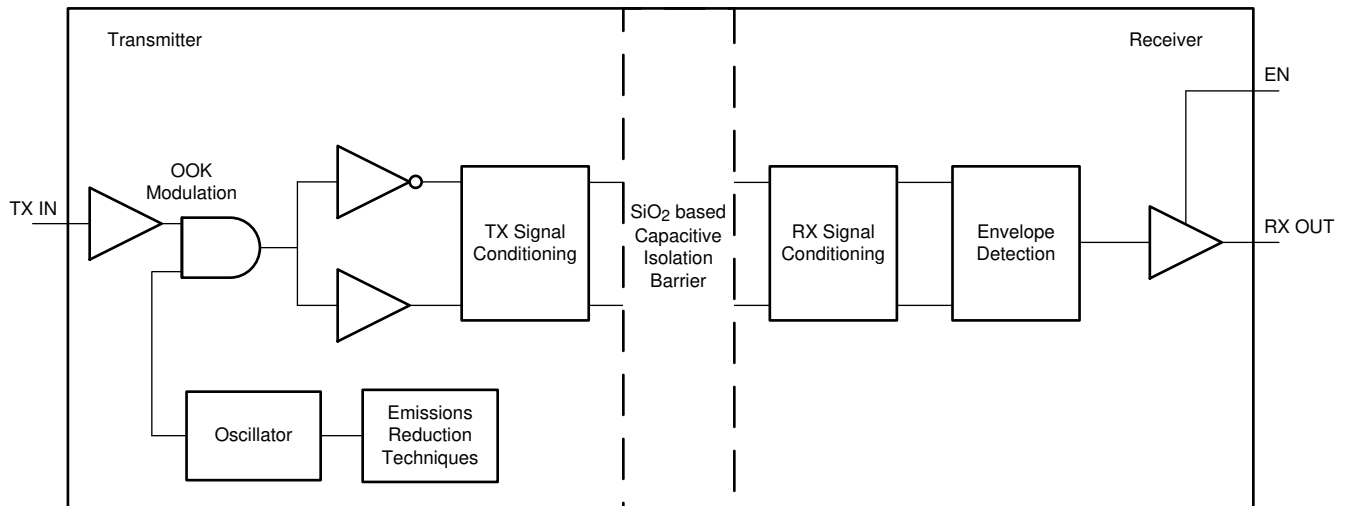

Copyright © 2016, Texas Instruments Incorporated

Figure 9-1. Conceptual Block Diagram of a Digital Capacitive Isolator

[Figure 9-2](#) shows a conceptual detail of how the ON-OFF keying scheme works.

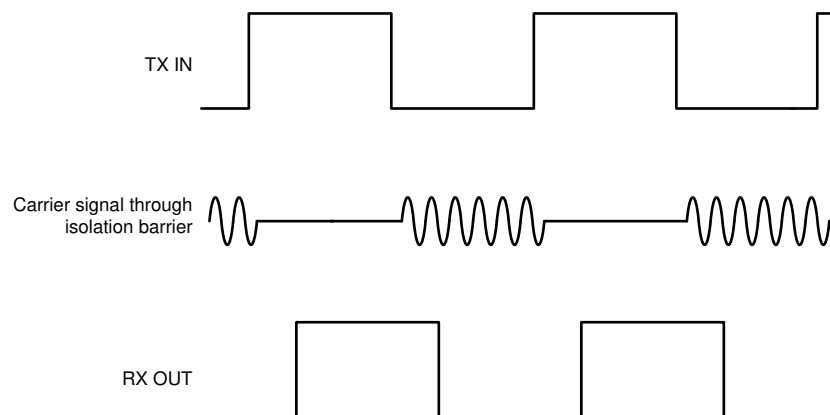

Figure 9-2. On-Off Keying (OOK) Based Modulation Scheme

9.3 Feature Description

Table 9-1 provides an overview of the device features.

Table 9-1. Device Features

PART NUMBER	CHANNEL DIRECTION	MAXIMUM DATA RATE	DEFAULT OUTPUT	PACKAGE	RATED ISOLATION ⁽¹⁾
ISOS141-SEP With F suffix	3 Forward, 1 Reverse	100 Mbps	Low	DBQ-16	3000 V _{RMS} / 4242 V _{PK}

(1) See Section 6.7 for detailed isolation ratings.

9.3.1 Radiation Tolerance

Total Ionizing Dose (TID)— ISOS141-SEP is a radiation tolerant, TI Space Enhanced Plastic (Space EP) device, and as such it has a Total Ionizing Dose (TID) level specified in the “Device Information” table on the front page. Testing and qualification of these products is done on a wafer level according to MIL-STD-883, Test Method 1019. Radiation Lot Acceptance Testing (RLAT) is performed at the 30-krad TID levels. A TID characterization report is available. Group E TID RLAT data are available with lot shipments as part of the QCI summary reports.

Single-Event Effects (SEE)— one-time SEE characterization was performed according to EIA/JEDEC standard, EIA/JEDEC57 to linear energy transfer (LET) = 43 MeV·cm²/mg. During testing, no Single-Event Latch-Up (SEL) or Single-Event Dielectric Rupture (SEDR) were observed.

Neutron Displacement Damage (NDD)— ISOS141-SEP was irradiated up to 1×10^{12} n/cm². A sample size of 15 units was exposed to radiation testing per MILSTD-883, Method 1017 for Neutron Irradiation.

Radiation Testing and Characterization Reports— are available for all radiation effects described in this section, to find the latest reports go to the [ISOS141-SEP Technical Documentation](#) section on TI.com.

9.3.2 Electromagnetic Compatibility (EMC) Considerations

Many applications in harsh industrial environment are sensitive to disturbances such as electrostatic discharge (ESD), electrical fast transient (EFT), surge and electromagnetic emissions. Although system-level performance and reliability depends, to a large extent, on the application board design and layout, the ISOS141-SEP device incorporates many chip-level design improvements for overall system robustness. Some of these improvements include:

- Robust ESD protection cells for input and output signal pins and inter-chip bond pads.
- Low-resistance connectivity of ESD cells to supply and ground pins.
- Enhanced performance of high voltage isolation capacitor for better tolerance of ESD, EFT and surge events.
- Bigger on-chip decoupling capacitors to bypass undesirable high energy signals through a low impedance path.
- PMOS and NMOS devices isolated from each other by using guard rings to avoid triggering of parasitic SCRs.
- Reduced common mode currents across the isolation barrier by ensuring purely differential internal operation.

9.4 Device Functional Modes

Table 9-2 lists the functional modes for the ISOS141-SEP.

Table 9-2. Function Table

V_{CCI}	V_{CCO}	INPUT (INx) ⁽²⁾	OUTPUT ENABLE (ENx)	OUTPUT (OUTx)	COMMENTS
PU	PU	H	H or open	H	Normal Operation: A channel output assumes the logic state of its input.
		L	H or open	L	
		Open	H or open	Default	Default mode: When INx is open, the corresponding channel output goes to its default logic state. Default is Low for ISOS141-SEP with F suffix.
X	PU	X	L	Z	A low value of output enable causes the outputs to be high-impedance.
PD	PU	X	H or open	Default	Default mode: When V_{CCI} is unpowered, a channel output assumes the logic state based on the selected default option. Default is Low for ISOS141-SEP with F suffix. When V_{CCI} transitions from unpowered to powered-up, a channel output assumes the logic state of the input. When V_{CCI} transitions from powered-up to unpowered, channel output assumes the selected default state.
X	PD	X	X	Undetermined	When V_{CCO} is unpowered, a channel output is undetermined ⁽¹⁾ . When V_{CCO} transitions from unpowered to powered-up, a channel output assumes the logic state of the input.

(1) The outputs are in undetermined state when $1.7\text{ V} < V_{CCI}$, $V_{CCO} < 2.25\text{ V}$.

(2) A strongly driven input signal can weakly power the floating V_{CC} through an internal protection diode and cause undetermined output.

9.4.1 Device I/O Schematics

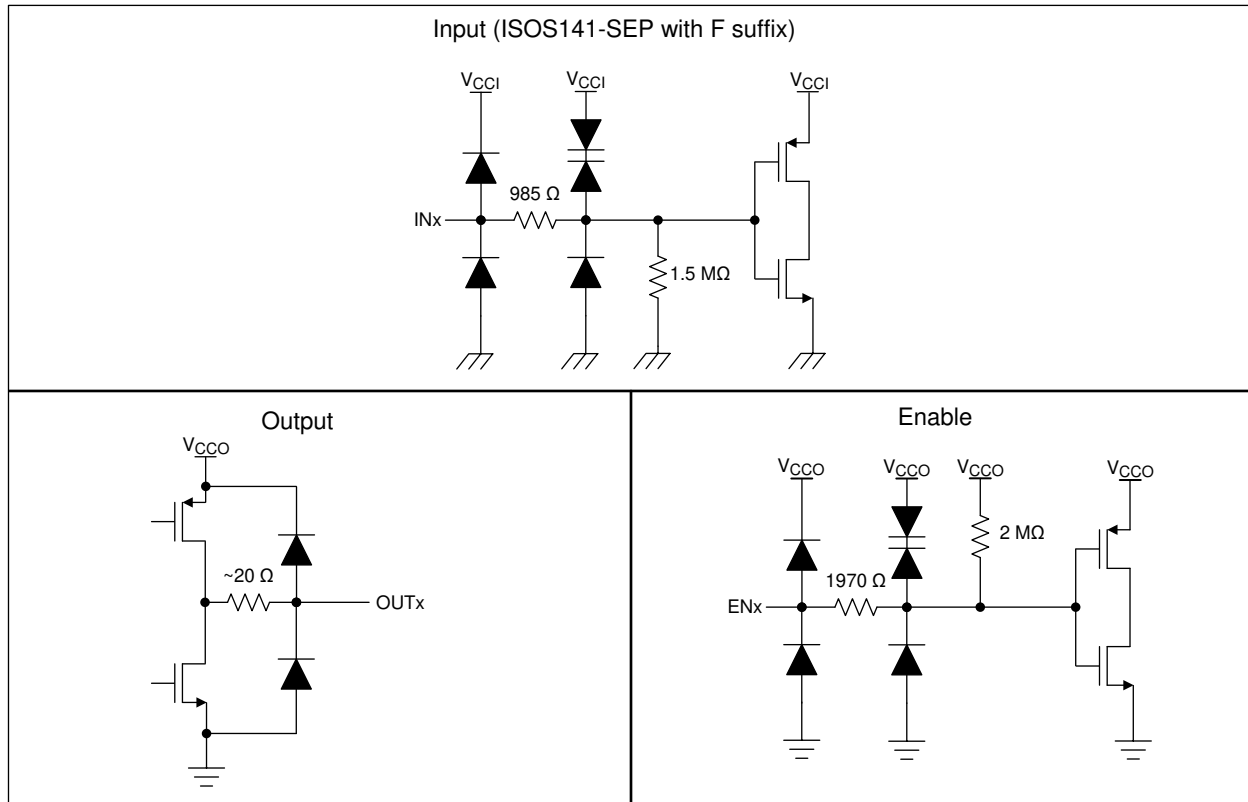

Figure 9-3. Device I/O Schematics

10 Application and Implementation

Note

Information in the following applications sections is not part of the TI component specification, and TI does not warrant its accuracy or completeness. TI's customers are responsible for determining suitability of components for their purposes. Customers should validate and test their design implementation to confirm system functionality.

10.1 Application Information

The ISOS141-SEP four channel digital isolator provides flexibility for multiple use cases in LEO applications. Used in conjunction with isolated power supplies, these devices help prevent noise currents on data buses, such as UART, SPI, RS-485, RS-232, and CAN from damaging sensitive circuitry. It can also be used to isolate multiple static signals in a system to provide additional redundancy and robustness. When designing with digital isolators, keep in mind that because of the single-ended design structure, digital isolators do not conform to any specific interface standard and are only intended for isolating single-ended CMOS or TTL digital signal lines. The isolator is typically placed between the data controller (that is, MCU or FPGA), and a data converter or a line transceiver, regardless of the interface type or standard.

Additionally, this digital isolator can be used as a logic-level translator in addition to providing isolation. Since an isolation barrier separates the two sides, each side can be sourced independently with any voltage within recommended operating conditions. The supply voltage range is from 2.25 V to 5.5 V for both supplies, V_{CC1} and V_{CC2} . As an example, it is possible to supply ISOS141-SEP V_{CC1} with 3.3 V (which is within 2.25 V to 5.5 V) and V_{CC2} with 5V (which is also within 2.25 V to 5.5 V).

10.2.1 Design Requirements

To design with these devices, use the parameters listed in [Table 10-1](#).

Table 10-1. Design Parameters

PARAMETER	VALUE
Supply voltage, V_{CC1} and V_{CC2}	2.25 to 5.5 V
Decoupling capacitor between V_{CC1} and GND1	0.1 μF
Decoupling capacitor from V_{CC2} and GND2	0.1 μF

10.2.2 Detailed Design Procedure

The ISOS141-SEP device only require two external bypass capacitors to operate.

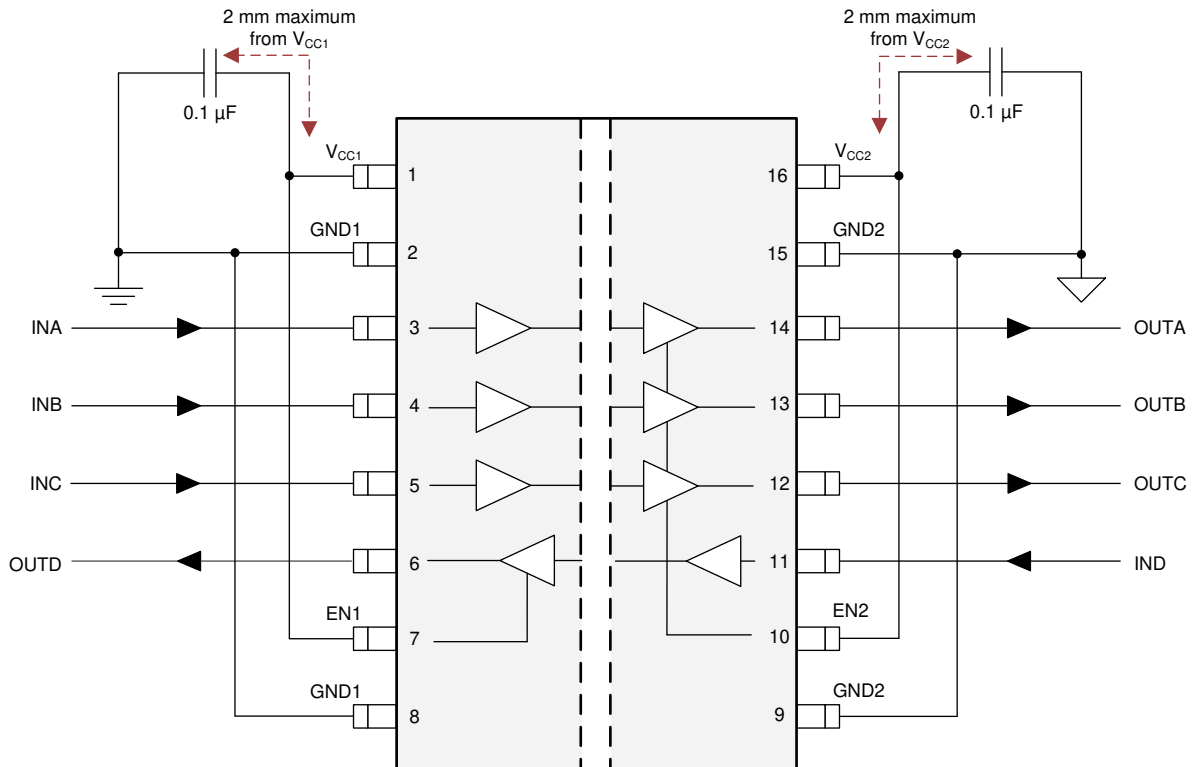
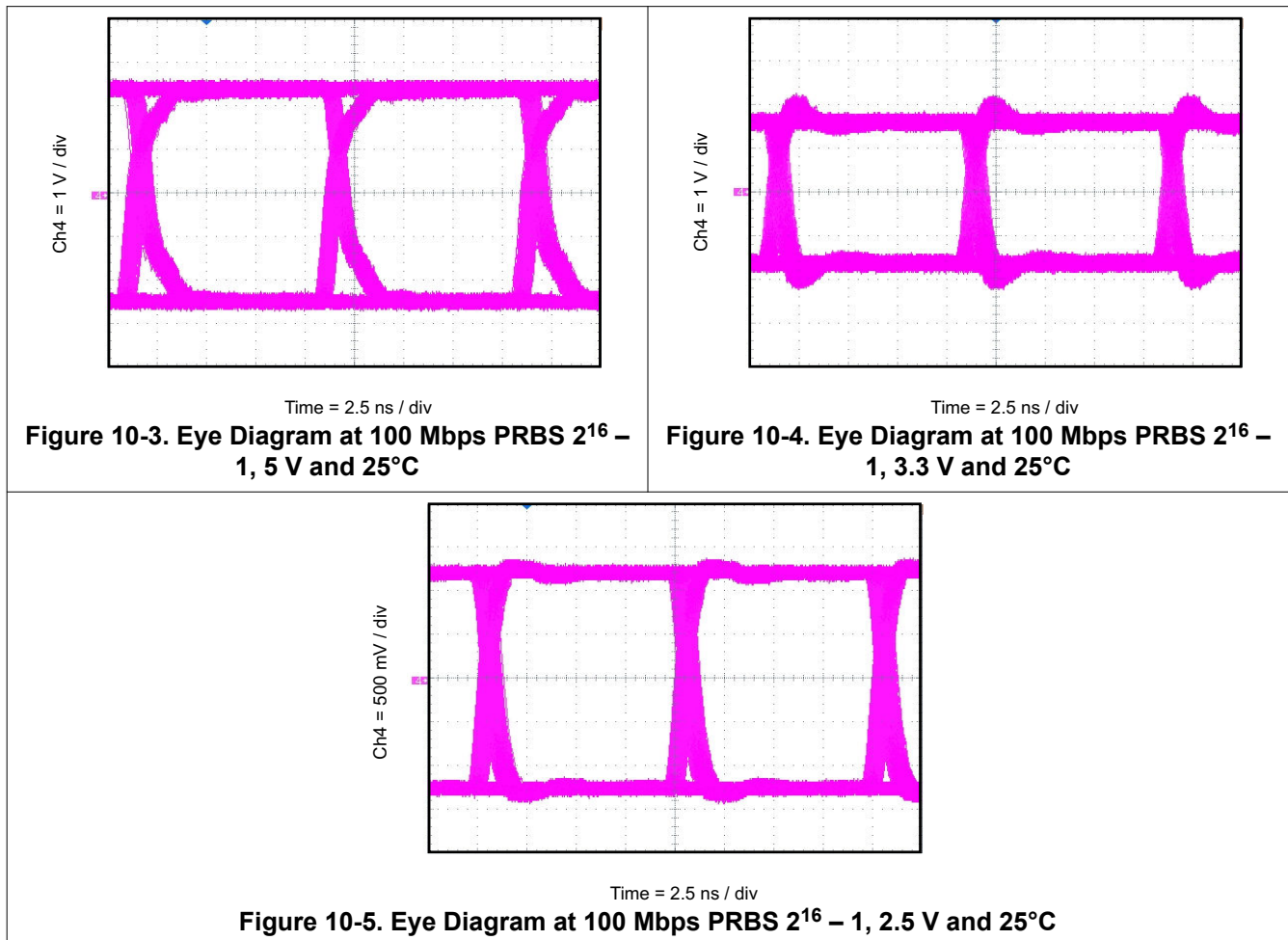

Figure 10-2. Typical ISOS141-SEP Circuit Hook-up

10.2.3 Application Curve

The following typical eye diagrams of the ISOS141-SEP device indicates low jitter and wide open eye at the maximum data rate of 100 Mbps.



10.2.3.1 Insulation Lifetime

Insulation lifetime projection data is collected by using industry-standard Time Dependent Dielectric Breakdown (TDDB) test method. In this test, all pins on each side of the barrier are tied together creating a two-terminal device and high voltage applied between the two sides; See Figure 10-6 for TDDB test setup. The insulation breakdown data is collected at various high voltages switching at 60 Hz over temperature. For reinforced insulation, VDE standard requires the use of TDDB projection line with failure rate of less than 1 part per million (ppm). Even though the expected minimum insulation lifetime is 20 years at the specified working isolation voltage, VDE reinforced certification requires additional safety margin of 20% for working voltage and 87.5% for lifetime which translates into minimum required insulation lifetime of 37.5 years at a working voltage that's 20% higher than the specified value.

Figure 10-7 shows the intrinsic capability of the isolation barrier to withstand high voltage stress over its lifetime. Based on the TDDB data, the insulation withstand capability of DBQ-16 package is 600 V_{RMS} with a lifetime of >1000 years as illustrated in Figure 10-7. Factors, such as package size, pollution degree, and material group can limit the working voltage of a component.

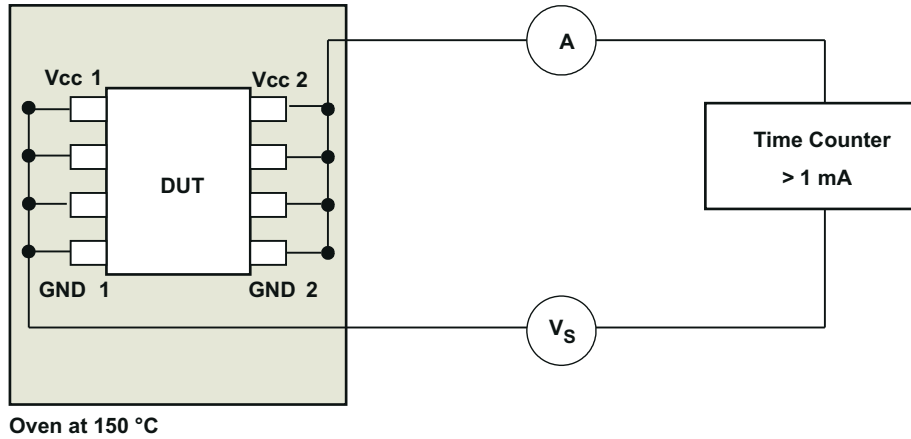

Figure 10-6. Test Setup for Insulation Lifetime Measurement

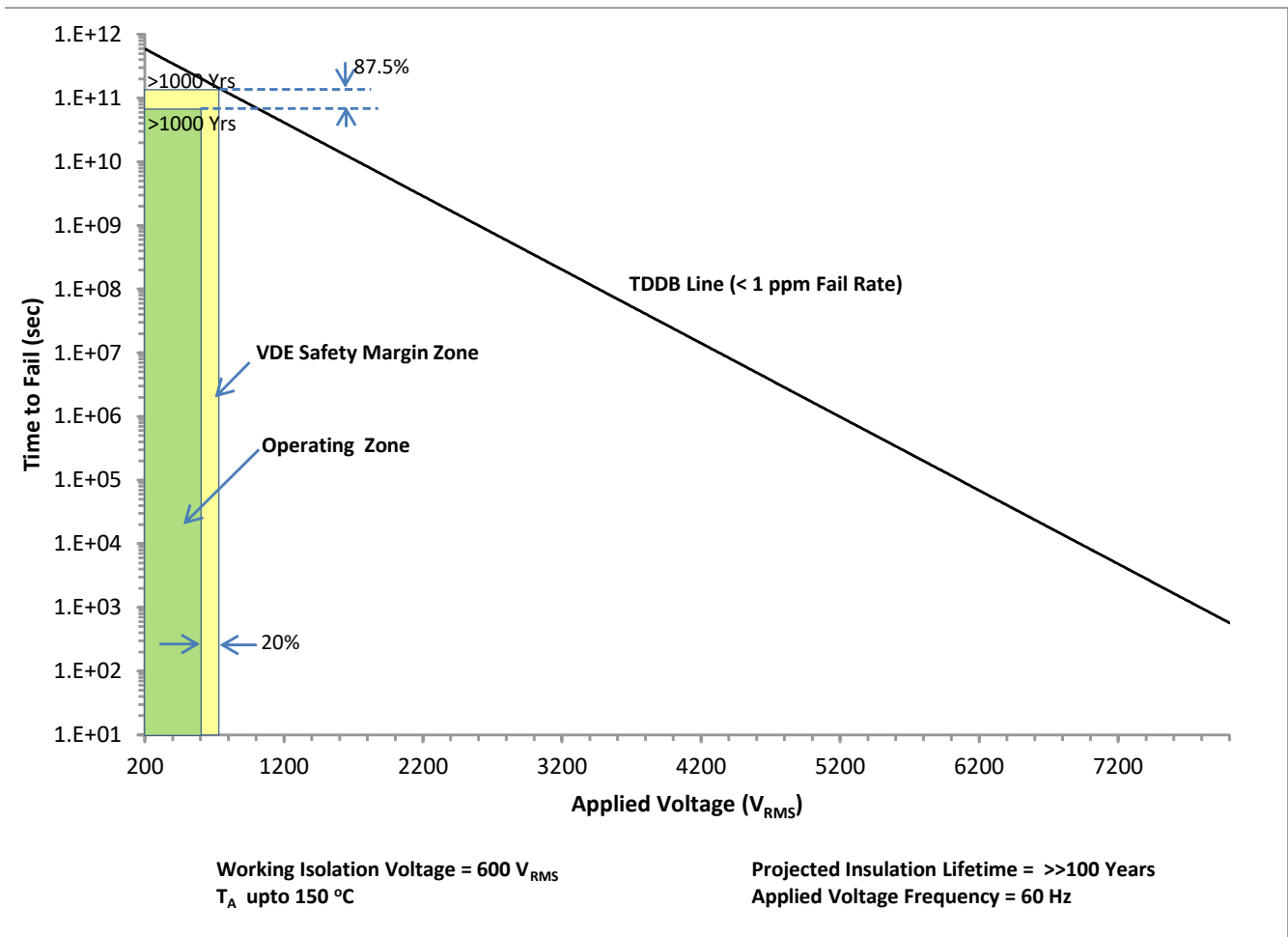

Figure 10-7. Insulation Lifetime Projection Data

11 Power Supply Recommendations

To help ensure reliable operation at data rates and supply voltages, a 0.1- μ F bypass capacitor is recommended at the input and output supply pins (V_{CC1} and V_{CC2}). The capacitors should be placed as close to the supply pins as possible.

12 Layout

12.1 Layout Guidelines

A minimum of four layers is required to accomplish a low EMI PCB design (see [Figure 12-1](#)). Layer stacking should be in the following order (top-to-bottom): high-speed signal layer, ground plane, power plane and low-frequency signal layer.

- Routing the high-speed traces on the top layer avoids the use of vias (and the introduction of their inductances) and allows for clean interconnects between the isolator and the transmitter and receiver circuits of the data link.
- Placing a solid ground plane next to the high-speed signal layer establishes controlled impedance for transmission line interconnects and provides an excellent low-inductance path for the return current flow.
- Placing the power plane next to the ground plane creates additional high-frequency bypass capacitance of approximately 100 pF/inch².
- Routing the slower speed control signals on the bottom layer allows for greater flexibility as these signal links usually have margin to tolerate discontinuities such as vias.

If an additional supply voltage plane or signal layer is needed, add a second power or ground plane system to the stack to keep it symmetrical. This makes the stack mechanically stable and prevents it from warping. Also the power and ground plane of each power system can be placed closer together, thus increasing the high-frequency bypass capacitance significantly.

For detailed layout recommendations, refer to the [Digital Isolator Design Guide](#).

12.1.1 PCB Material

For digital circuit boards operating below 150 Mbps, (or rise and fall times higher than 1 ns), and trace lengths of up to 10 inches, use standard FR-4 UL94V-0 printed circuit boards. This PCB is preferred over cheaper alternatives due to its lower dielectric losses at high frequencies, less moisture absorption, greater strength and stiffness, and self-extinguishing flammability-characteristics.

12.2 Layout Example

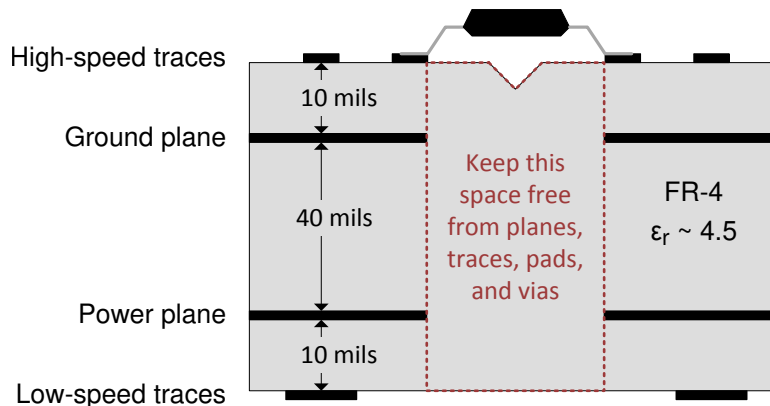

Figure 12-1. Layout Example Schematic

13 Device and Documentation Support

13.1 Documentation Support

13.1.1 Related Documentation

For related documentation, see the following:

- Texas Instruments, [Radiation hardened 3.3V CAN transceiver in space enhanced plastic package with standby mode datasheet](#)
- Texas Instruments, [Radiation hardened RS-422 dual differential drivers and receivers in space Enhanced Plastic datasheet](#)
- Texas Instruments, [Radiation-hardened, 2.2-V to 20-V, 1-A low-noise adjustable output LDO in Space Enhanced Plastic datasheet](#)
- Texas Instruments, [Digital Isolator Design Guide](#)
- Texas Instruments, [Isolation Glossary](#)
- Texas Instruments, [How to use isolation to improve ESD, EFT, and Surge immunity in industrial systems application report](#)

13.2 Receiving Notification of Documentation Updates

To receive notification of documentation updates, navigate to the device product folder on ti.com. In the upper right corner, click on *Alert me* to register and receive a weekly digest of any product information that has changed. For change details, review the revision history included in any revised document.

13.3 Community Resources

13.4 Trademarks

All trademarks are the property of their respective owners.

14 Mechanical, Packaging, and Orderable Information

The following pages include mechanical packaging and orderable information. This information is the most current data available for the designated devices. This data is subject to change without notice and revision of this document. For browser-based versions of this data sheet, refer to the left-hand navigation.



DBQ0016A

PACKAGE OUTLINE SSOP - 1.75 mm max height

SHRINK SMALL-OUTLINE PACKAGE

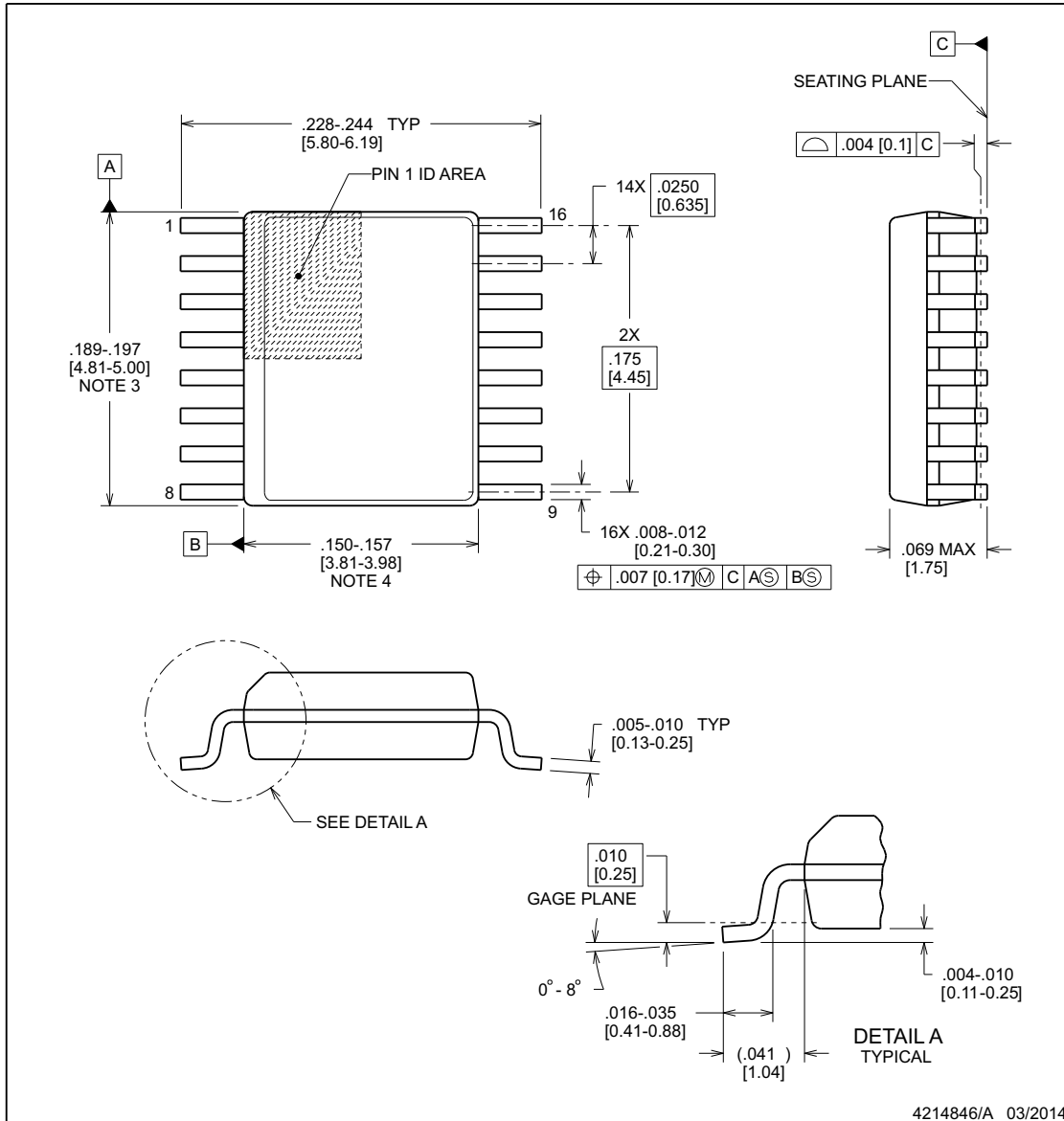

NOTES:

1. Linear dimensions are in inches [millimeters]. Dimensions in parenthesis are for reference only. Controlling dimensions are in inches. Dimensioning and tolerancing per ASME Y14.5M.
2. This drawing is subject to change without notice.
3. This dimension does not include mold flash, protrusions, or gate burrs. Mold flash, protrusions, or gate burrs shall not exceed .006 inch, per side.
4. This dimension does not include interlead flash.
5. Reference JEDEC registration MO-137, variation AB.

www.ti.com

EXAMPLE BOARD LAYOUT

D0008A

SOIC - 1.75 mm max height

SMALL OUTLINE INTEGRATED CIRCUIT

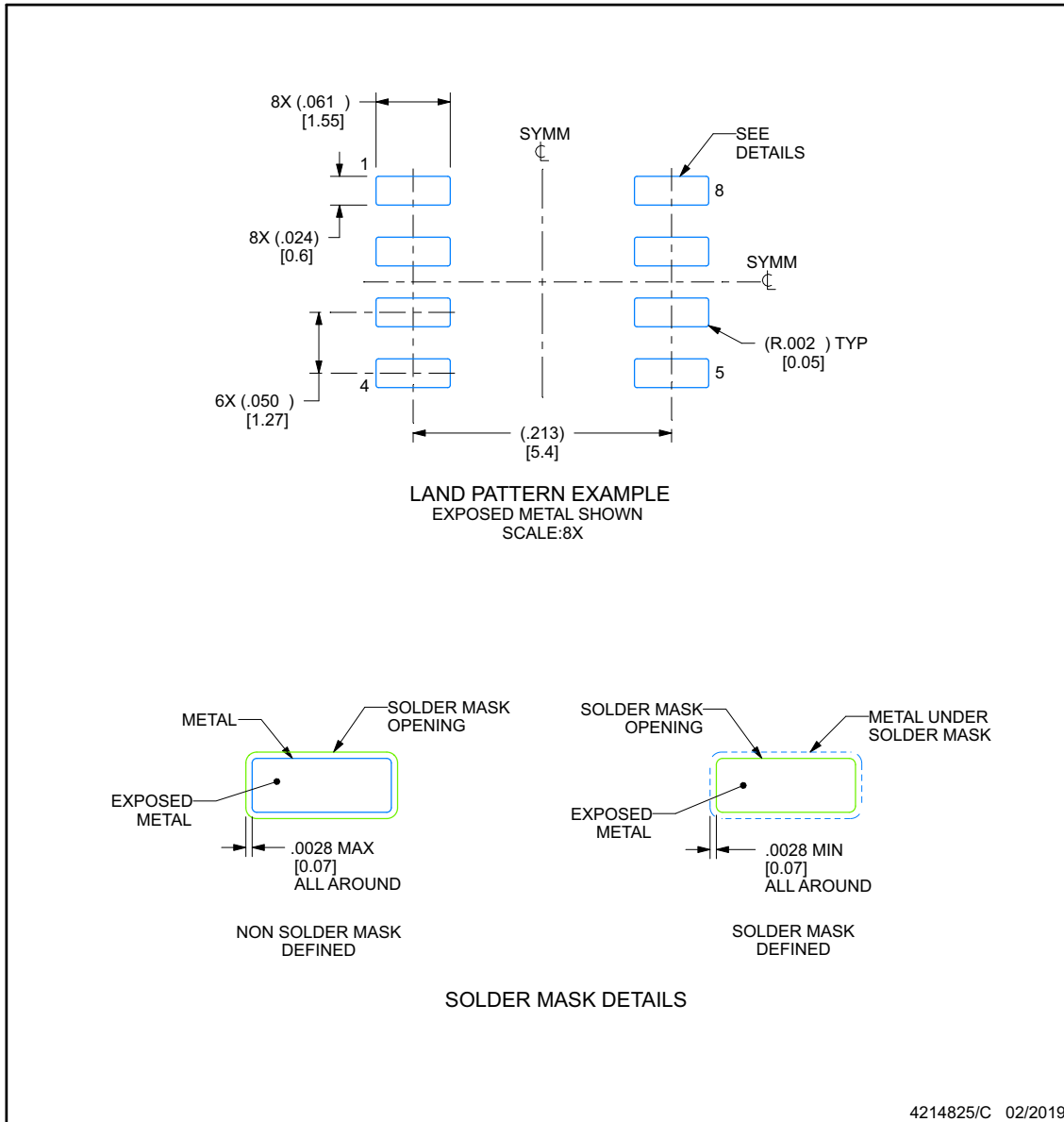

NOTES: (continued)

- 6. Publication IPC-7351 may have alternate designs.
- 7. Solder mask tolerances between and around signal pads can vary based on board fabrication site.

EXAMPLE STENCIL DESIGN

DBQ0016A

SSOP - 1.75 mm max height

SHRINK SMALL-OUTLINE PACKAGE

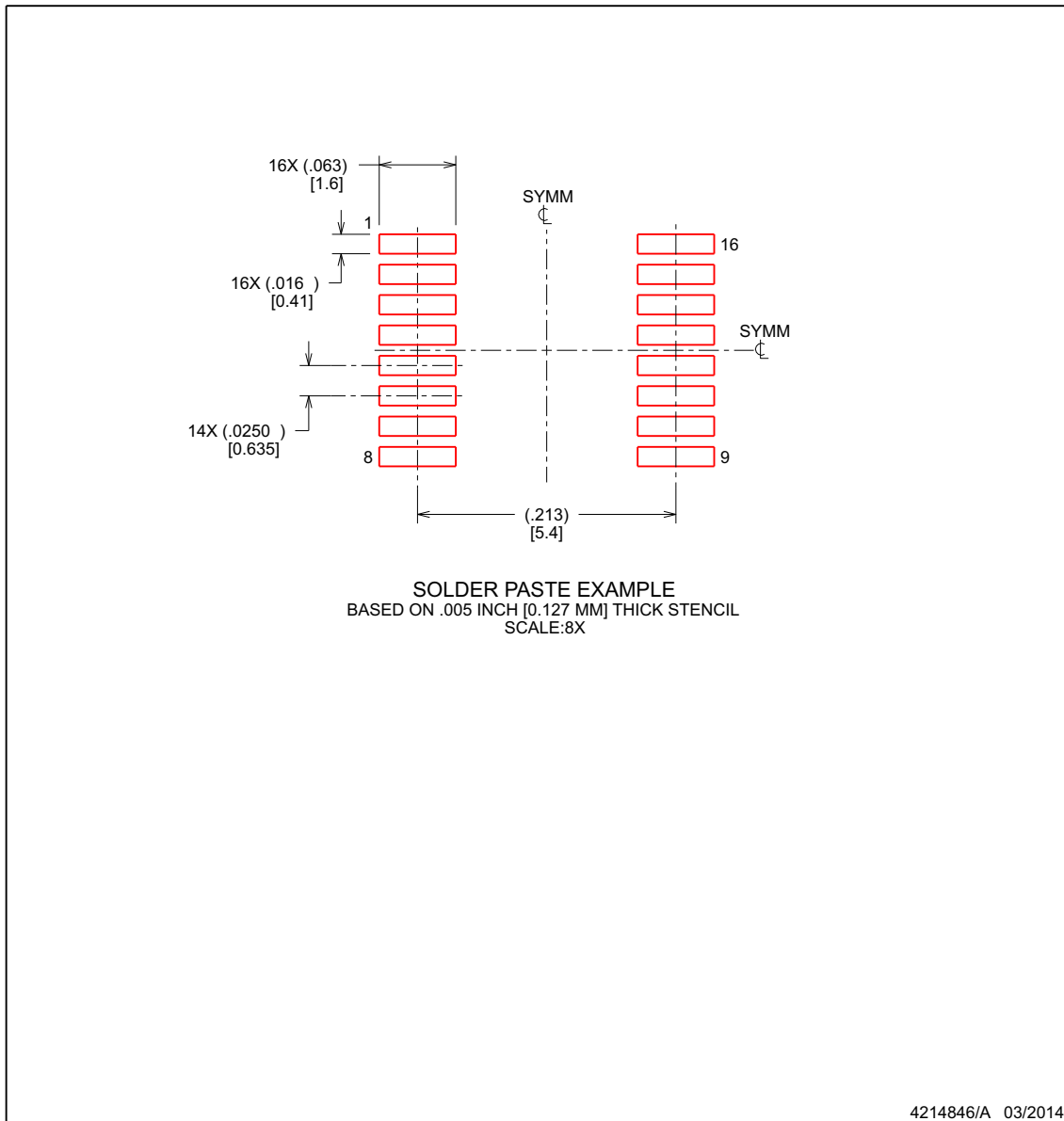

NOTES: (continued)

8. Laser cutting apertures with trapezoidal walls and rounded corners may offer better paste release. IPC-7525 may have alternate design recommendations.
9. Board assembly site may have different recommendations for stencil design.

www.ti.com

PACKAGING INFORMATION

Orderable Device	Status (1)	Package Type	Package Drawing	Pins	Package Qty	Eco Plan (2)	Lead finish/ Ball material (6)	MSL Peak Temp (3)	Op Temp (°C)	Device Marking (4/5)	Samples
ISOS141FDBQSEP	ACTIVE	SSOP	DBQ	16	75	RoHS & Green	NIPDAU	Level-2-260C-1 YEAR	-55 to 125	141FSE	Samples
ISOS141FDBQTSEP	ACTIVE	SSOP	DBQ	16	250	RoHS & Green	NIPDAU	Level-2-260C-1 YEAR	-55 to 125	141FSE	Samples
V62/21610-01XE	ACTIVE	SSOP	DBQ	16	250	RoHS & Green	NIPDAU	Level-2-260C-1 YEAR		141FSE	Samples
V62/21610-01XE-T	ACTIVE	SSOP	DBQ	16	75	RoHS & Green	NIPDAU	Level-2-260C-1 YEAR		141FSE	Samples

(1) The marketing status values are defined as follows:

ACTIVE: Product device recommended for new designs.

LIFEBUY: TI has announced that the device will be discontinued, and a lifetime-buy period is in effect.

NRND: Not recommended for new designs. Device is in production to support existing customers, but TI does not recommend using this part in a new design.

PREVIEW: Device has been announced but is not in production. Samples may or may not be available.

OBSOLETE: TI has discontinued the production of the device.

(2) **RoHS:** TI defines "RoHS" to mean semiconductor products that are compliant with the current EU RoHS requirements for all 10 RoHS substances, including the requirement that RoHS substance do not exceed 0.1% by weight in homogeneous materials. Where designed to be soldered at high temperatures, "RoHS" products are suitable for use in specified lead-free processes. TI may reference these types of products as "Pb-Free".

RoHS Exempt: TI defines "RoHS Exempt" to mean products that contain lead but are compliant with EU RoHS pursuant to a specific EU RoHS exemption.

Green: TI defines "Green" to mean the content of Chlorine (Cl) and Bromine (Br) based flame retardants meet JS709B low halogen requirements of <=1000ppm threshold. Antimony trioxide based flame retardants must also meet the <=1000ppm threshold requirement.

(3) MSL, Peak Temp. - The Moisture Sensitivity Level rating according to the JEDEC industry standard classifications, and peak solder temperature.

(4) There may be additional marking, which relates to the logo, the lot trace code information, or the environmental category on the device.

(5) Multiple Device Markings will be inside parentheses. Only one Device Marking contained in parentheses and separated by a "-" will appear on a device. If a line is indented then it is a continuation of the previous line and the two combined represent the entire Device Marking for that device.

(6) Lead finish/Ball material - Orderable Devices may have multiple material finish options. Finish options are separated by a vertical ruled line. Lead finish/Ball material values may wrap to two lines if the finish value exceeds the maximum column width.

Important Information and Disclaimer:The information provided on this page represents TI's knowledge and belief as of the date that it is provided. TI bases its knowledge and belief on information provided by third parties, and makes no representation or warranty as to the accuracy of such information. Efforts are underway to better integrate information from third parties. TI has taken and

continues to take reasonable steps to provide representative and accurate information but may not have conducted destructive testing or chemical analysis on incoming materials and chemicals. TI and TI suppliers consider certain information to be proprietary, and thus CAS numbers and other limited information may not be available for release.

In no event shall TI's liability arising out of such information exceed the total purchase price of the TI part(s) at issue in this document sold by TI to Customer on an annual basis.

TAPE AND REEL INFORMATION

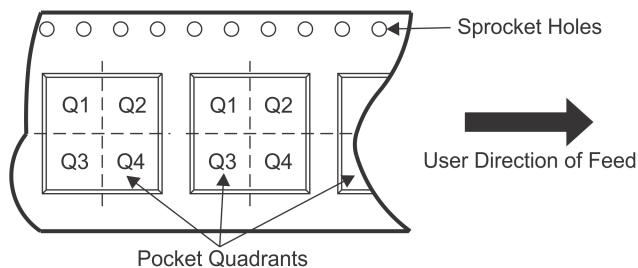
QUADRANT ASSIGNMENTS FOR PIN 1 ORIENTATION IN TAPE

*All dimensions are nominal

Device	Package Type	Package Drawing	Pins	SPQ	Reel Diameter (mm)	Reel Width W1 (mm)	A0 (mm)	B0 (mm)	K0 (mm)	P1 (mm)	W (mm)	Pin1 Quadrant
ISOS141FDBQTSEP	SSOP	DBQ	16	250	330.0	12.4	6.4	5.2	2.1	8.0	12.0	Q1

TAPE AND REEL BOX DIMENSIONS

*All dimensions are nominal

Device	Package Type	Package Drawing	Pins	SPQ	Length (mm)	Width (mm)	Height (mm)
ISOS141FDBQTSEP	SSOP	DBQ	16	250	350.0	350.0	43.0

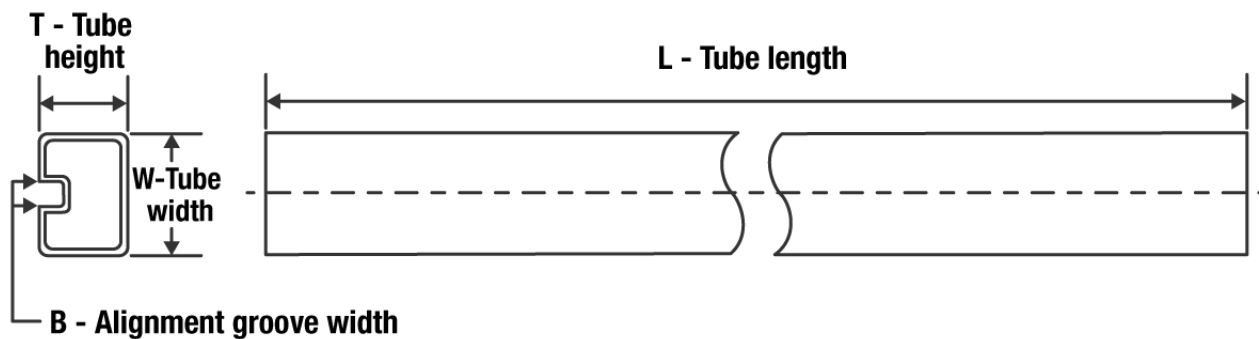
TUBE

*All dimensions are nominal

Device	Package Name	Package Type	Pins	SPQ	L (mm)	W (mm)	T (μm)	B (mm)
ISOS141FDBQSEP	DBQ	SSOP	16	75	505.46	6.76	3810	4
V62/21610-01XE-T	DBQ	SSOP	16	75	505.46	6.76	3810	4

EXAMPLE BOARD LAYOUT

DBQ0016A

SSOP - 1.75 mm max height

SHRINK SMALL-OUTLINE PACKAGE

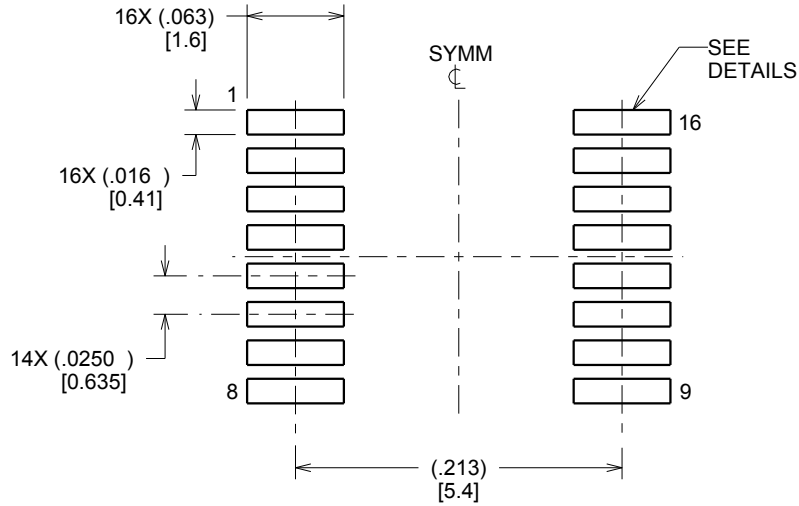

LAND PATTERN EXAMPLE
SCALE:8X

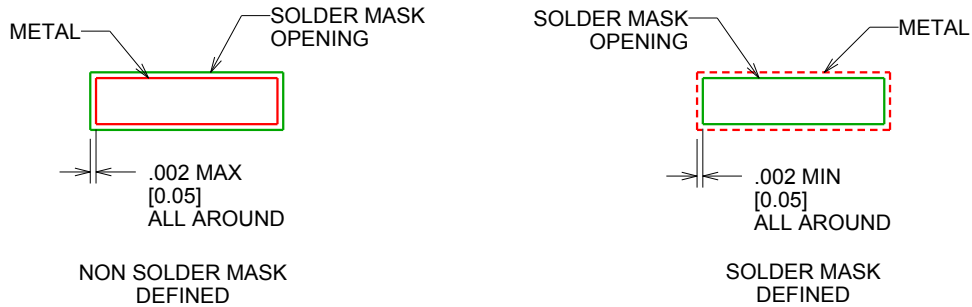

SOLDER MASK DETAILS

4214846/A 03/2014

NOTES: (continued)

- 6. Publication IPC-7351 may have alternate designs.
- 7. Solder mask tolerances between and around signal pads can vary based on board fabrication site.

EXAMPLE STENCIL DESIGN

DBQ0016A

SSOP - 1.75 mm max height

SHRINK SMALL-OUTLINE PACKAGE

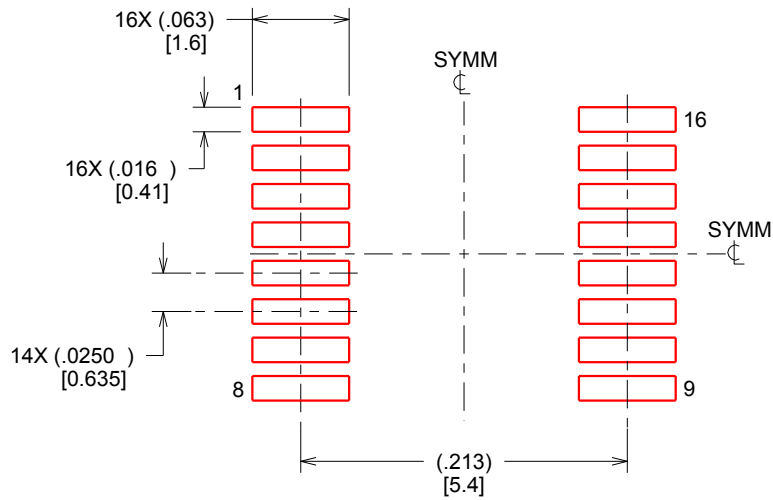

SOLDER PASTE EXAMPLE
BASED ON .005 INCH [0.127 MM] THICK STENCIL
SCALE:8X

4214846/A 03/2014

NOTES: (continued)

8. Laser cutting apertures with trapezoidal walls and rounded corners may offer better paste release. IPC-7525 may have alternate design recommendations.
9. Board assembly site may have different recommendations for stencil design.

IMPORTANT NOTICE AND DISCLAIMER

TI PROVIDES TECHNICAL AND RELIABILITY DATA (INCLUDING DATA SHEETS), DESIGN RESOURCES (INCLUDING REFERENCE DESIGNS), APPLICATION OR OTHER DESIGN ADVICE, WEB TOOLS, SAFETY INFORMATION, AND OTHER RESOURCES "AS IS" AND WITH ALL FAULTS, AND DISCLAIMS ALL WARRANTIES, EXPRESS AND IMPLIED, INCLUDING WITHOUT LIMITATION ANY IMPLIED WARRANTIES OF MERCHANTABILITY, FITNESS FOR A PARTICULAR PURPOSE OR NON-INFRINGEMENT OF THIRD PARTY INTELLECTUAL PROPERTY RIGHTS.

These resources are intended for skilled developers designing with TI products. You are solely responsible for (1) selecting the appropriate TI products for your application, (2) designing, validating and testing your application, and (3) ensuring your application meets applicable standards, and any other safety, security, regulatory or other requirements.

These resources are subject to change without notice. TI grants you permission to use these resources only for development of an application that uses the TI products described in the resource. Other reproduction and display of these resources is prohibited. No license is granted to any other TI intellectual property right or to any third party intellectual property right. TI disclaims responsibility for, and you will fully indemnify TI and its representatives against, any claims, damages, costs, losses, and liabilities arising out of your use of these resources.

TI's products are provided subject to [TI's Terms of Sale](#) or other applicable terms available either on ti.com or provided in conjunction with such TI products. TI's provision of these resources does not expand or otherwise alter TI's applicable warranties or warranty disclaimers for TI products.

TI objects to and rejects any additional or different terms you may have proposed.

Mailing Address: Texas Instruments, Post Office Box 655303, Dallas, Texas 75265
Copyright © 2022, Texas Instruments Incorporated