

LM120/LM320-N Series 3-Terminal Negative Regulators

 Check for Samples: [LM120](#), [LM320-N](#)

FEATURES

- Preset Output Voltage Error Less than $\pm 3\%$
- Preset Current Limit
- Internal Thermal Shutdown
- Operates with Input-Output Voltage Differential down to 1V
- Excellent Ripple Rejection
- Low Temperature Drift
- Easily Adjustable to Higher Output Voltage

DESCRIPTION

The LM120 series are three-terminal negative regulators with a fixed output voltage of $-5V$, $-12V$, and $-15V$, and up to 1.5A load current capability. Where other voltages are required, the LM137 and LM137HV series provide an output voltage range of $-1.2V$ to $-47V$.

The LM120 need only one external component—a compensation capacitor at the output, making them easy to apply. Worst case specifications on output voltage deviation due to any combination of line, load or temperature variation assure satisfactory system operation.

Typical Applications

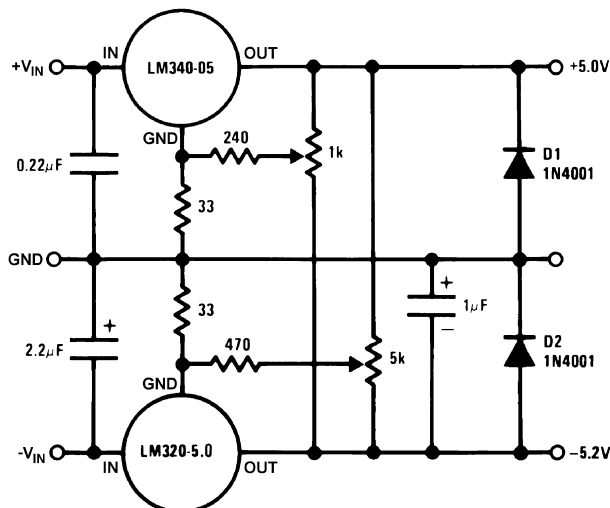

Figure 1. Dual Trimmed Supply

Exceptional effort has been made to make the LM120 Series immune to overload conditions. The regulators have current limiting which is independent of temperature, combined with thermal overload protection. Internal current limiting protects against momentary faults while thermal shutdown prevents junction temperatures from exceeding safe limits during prolonged overloads.

Although primarily intended for fixed output voltage applications, the LM120 Series may be programmed for higher output voltages with a simple resistive divider. The low quiescent drain current of the devices allows this technique to be used with good regulation.

Table 1. LM120 Series Packages and Power Capability

Device	Package	Rated Power Dissipation	Design Load Current
LM120/LM320-N	TO-3 (NDS)	20W	1.5A
	TO (NDT)	2W	0.5A
LM320-N	TO-220 (NDE)	15W	1.5A

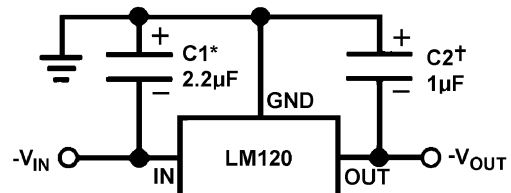

*Required if regulator is separated from filter capacitor by more than 3 inches. For value given, capacitor must be solid tantalum. 25 μF aluminum electrolytic may be substituted.

†Required for stability. For value given, capacitor must be solid tantalum. 25 μF aluminum electrolytic may be substituted. Values given may be increased without limit.

For output capacitance in excess of 100 μF , a high current diode from input to output (1N4001, etc.) will protect the regulator from momentary input shorts.

Figure 2. Fixed Regulator



Please be aware that an important notice concerning availability, standard warranty, and use in critical applications of Texas Instruments semiconductor products and disclaimers thereto appears at the end of this data sheet.

All trademarks are the property of their respective owners.



These devices have limited built-in ESD protection. The leads should be shorted together or the device placed in conductive foam during storage or handling to prevent electrostatic damage to the MOS gates.

ABSOLUTE MAXIMUM RATINGS–5 VOLT REGULATORS⁽¹⁾⁽²⁾⁽³⁾

Power Dissipation	Internally Limited
Input Voltage	-25V
Input-Output Voltage Differential	25V
Junction Temperatures	(4)
Storage Temperature Range	-65°C to +150°C
Lead Temperature	
(Soldering, 10 sec.)	300°C
Plastic	260°C

- (1) Refer to RETS120-5H drawing for LM120H-5.0 or RETS120-5K drawing for LM120-5K military specifications.
- (2) For -5V 3 amp regulators, see LM145 data sheet.
- (3) If Military/Aerospace specified devices are required, please contact the Texas Instruments Sales Office/Distributors for availability and specifications.
- (4) This specification applies over $-55^{\circ}\text{C} \leq T_J \leq +150^{\circ}\text{C}$ for the LM120 and $0^{\circ}\text{C} \leq T_J \leq +125^{\circ}\text{C}$ for the LM320-N.

LM120K-5.0 AND LM320K-5.0 ELECTRICAL CHARACTERISTICS⁽¹⁾

Order Numbers		Metal Can Package						Units
		LM120K-5.0 (TO-3)			LM320K-5.0 (TO-3)			
Design Output Current (I_D) Device Dissipation (P_D)		1.5A 20W						Units
Parameter	Conditions ⁽²⁾	Min	Typ	Max	Min	Typ	Max	
Output Voltage	$T_J = 25^{\circ}\text{C}$, $V_{IN} = 10\text{V}$, $I_{LOAD} = 5\text{ mA}$	-5.1	-5	-4.9	-5.2	-5	-4.8	V
Line Regulation	$T_J = 25^{\circ}\text{C}$, $I_{LOAD} = 5\text{ mA}$, $V_{MIN} \leq V_{IN} \leq V_{MAX}$		10	25		10	40	mV
Input Voltage		-25		-7	-25		-7	V
Ripple Rejection	$f = 120\text{ Hz}$	54	64		54	64		dB
Load Regulation, (3)	$T_J = 25^{\circ}\text{C}$, $V_{IN} = 10\text{V}$, $5\text{ mA} \leq I_{LOAD} \leq I_D$		50	75		60	100	mV
Output Voltage, (2)	$-7.5\text{V} \leq V_{IN} \leq V_{MAX}$, $5\text{ mA} \leq I_{LOAD} \leq I_D$, $P \leq P_D$	-5.20		-4.80	-5.25		-4.75	V
Quiescent Current	$V_{MIN} \leq V_{IN} \leq V_{MAX}$		1	2		1	2	mA
Quiescent Current Change	$T_J = 25^{\circ}\text{C}$ $V_{MIN} \leq V_{IN} \leq V_{MAX}$ $5\text{ mA} \leq I_{LOAD} \leq I_D$		0.1	0.4		0.1	0.4	mA
Output Noise Voltage	$T_A = 25^{\circ}\text{C}$, $C_L = 1\text{ }\mu\text{F}$, $I_L = 5\text{ mA}$, $V_{IN} = 10\text{V}$, $10\text{ Hz} \leq f \leq 100\text{ kHz}$		150			150		μV
Long Term Stability			5	50		5	50	mV
Thermal Resistance								
Junction to Case				3			3	$^{\circ}\text{C/W}$
Junction to Ambient				35			35	$^{\circ}\text{C/W}$

- (1) For -5V 3 amp regulators, see LM145 data sheet.
- (2) This specification applies over $-55^{\circ}\text{C} \leq T_J \leq +150^{\circ}\text{C}$ for the LM120 and $0^{\circ}\text{C} \leq T_J \leq +125^{\circ}\text{C}$ for the LM320-N.
- (3) Regulation is measured at constant junction temperature. Changes in output voltage due to heating effects must be taken into account separately. To ensure constant junction temperature, low duty cycle, pulse testing is used. The LM120/LM320-N series does have low thermal feedback, improving line and load regulation. On all other tests, even though power dissipation is internally limited, electrical specifications apply only up to P_D .

LM120H-5.0 ELECTRICAL CHARACTERISTICS⁽¹⁾

Order Numbers		Metal Can Package			Units
		LM120H-5.0 (TO)			
Design Output Current (I_D) Device Dissipation (P_D)		0.5A 2W			
Parameter	Conditions ⁽²⁾	Min	Typ	Max	
Output Voltage	$T_J = 25^\circ\text{C}$, $V_{IN} = 10\text{V}$, $I_{LOAD} = 5\text{ mA}$	-5.1	-5	-4.9	V
Line Regulation	$T_J = 25^\circ\text{C}$, $I_{LOAD} = 5\text{ mA}$, $V_{MIN} \leq V_{IN} \leq V_{MAX}$		10	25	mV
Input Voltage		-25		-7	V
Ripple Rejection	$f = 120\text{ Hz}$	54	64		dB
Load Regulation, ⁽³⁾	$T_J = 25^\circ\text{C}$, $V_{IN} = 10\text{V}$, $5\text{ mA} \leq I_{LOAD} \leq I_D$		30	50	mV
Output Voltage, ⁽⁴⁾	$-7.5\text{V} \leq V_{IN} \leq V_{MAX}$, $5\text{ mA} \leq I_{LOAD} \leq I_D$, $P \leq P_D$	-5.20		-4.80	V
Quiescent Current	$V_{MIN} \leq V_{IN} \leq V_{MAX}$		1	2	mA
Quiescent Current Change	$T_J = 25^\circ\text{C}$ $V_{MIN} \leq V_{IN} \leq V_{MAX}$ $5\text{ mA} \leq I_{LOAD} \leq I_D$		0.05 0.04	0.4 0.4	mA mA
Output Noise Voltage	$T_A = 25^\circ\text{C}$, $C_L = 1\ \mu\text{F}$, $I_L = 5\text{ mA}$, $V_{IN} = 10\text{V}$, $10\text{ Hz} \leq f \leq 100\text{ kHz}$		150		μV
Long Term Stability			5		mV
Thermal Resistance Junction to Case				(5)	$^\circ\text{C/W}$
Junction to Ambient				(5)	$^\circ\text{C/W}$

(1) For -5V 3 amp regulators, see LM145 data sheet.

(2) This specification applies over $-55^\circ\text{C} \leq T_J \leq +150^\circ\text{C}$ for the LM120 and $0^\circ\text{C} \leq T_J \leq +125^\circ\text{C}$ for the LM320-N.

(3) Regulation is measured at constant junction temperature. Changes in output voltage due to heating effects must be taken into account separately. To ensure constant junction temperature, low duty cycle, pulse testing is used. The LM120/LM320-N series does have low thermal feedback, improving line and load regulation. On all other tests, even though power dissipation is internally limited, electrical specifications apply only up to P_D .

(4) This specification applies over $-55^\circ\text{C} \leq T_J \leq +150^\circ\text{C}$ for the LM120 and $0^\circ\text{C} \leq T_J \leq +125^\circ\text{C}$ for the LM320-N.

(5) Thermal resistance of typically 85°C/W (in 400 linear feet air flow), 224°C/W (in static air) junction to ambient, of typically 21°C/W junction to case.

ABSOLUTE MAXIMUM RATINGS–12 VOLT REGULATORS⁽¹⁾⁽²⁾

Power Dissipation	Internally Limited
Input Voltage	-35V
Input-Output Voltage Differential	30V
Junction Temperatures	⁽³⁾
Storage Temperature Range	-65°C to $+150^\circ\text{C}$
Lead Temperature	
(Soldering, 10 sec.)	300 $^\circ\text{C}$

(1) Refer to RETS120H-12 drawing for LM120H-12 or RETS120-12K drawing for LM120K-12 military specifications.

(2) If Military/Aerospace specified devices are required, please contact the Texas Instruments Sales Office/Distributors for availability and specifications.

(3) This specification applies over $-55^\circ\text{C} \leq T_J \leq +150^\circ\text{C}$ for the LM120 and $0^\circ\text{C} \leq T_J \leq +125^\circ\text{C}$ for the LM320-N.

LM120K-12 ELECTRICAL CHARACTERISTICS

Order Numbers		Metal Can Package			Units
		LM120K-12 (TO-3)			
Design Output Current (I_D)		1A			
Device Dissipation (P_D)		20W			
Parameter	Conditions ⁽¹⁾	Min	Typ	Max	
Output Voltage	$T_J = 25^\circ\text{C}$, $V_{IN} = 17\text{V}$, $I_{LOAD} = 5\text{ mA}$	-12.3	-12	-11.7	V
Line Regulation	$T_J = 25^\circ\text{C}$, $I_{LOAD} = 5\text{ mA}$, $V_{MIN} \leq V_{IN} \leq V_{MAX}$		4	10	mV
Input Voltage		-32		-14	V
Ripple Rejection	$f = 120\text{ Hz}$	56	80		dB
Load Regulation, (2)	$T_J = 25^\circ\text{C}$, $V_{IN} = 17\text{V}$, $5\text{ mA} \leq I_{LOAD} \leq I_D$		30	80	mV
Output Voltage, (3)	$14.5\text{V} \leq V_{IN} \leq V_{MAX}$, $5\text{ mA} \leq I_{LOAD} \leq I_D$, $P \leq P_D$	-12.5		-11.5	V
Quiescent Current	$V_{MIN} \leq V_{IN} \leq V_{MAX}$		2	4	mA
Quiescent Current Change	$T_J = 25^\circ\text{C}$ $V_{MIN} \leq V_{IN} \leq V_{MAX}$ $5\text{ mA} \leq I_{LOAD} \leq I_D$		0.1 0.1	0.4 0.4	mA mA
Output Noise Voltage	$T_A = 25^\circ\text{C}$, $C_L = 1\text{ }\mu\text{F}$, $I_L = 5\text{ mA}$, $V_{IN} = 17\text{V}$, $10\text{ Hz} \leq f \leq 100\text{ kHz}$		400		μV
Long Term Stability			12	120	mV
Thermal Resistance					
Junction to Case				3	$^\circ\text{C/W}$
Junction to Ambient				35	$^\circ\text{C/W}$

(1) This specification applies over $-55^\circ\text{C} \leq T_J \leq +150^\circ\text{C}$ for the LM120 and $0^\circ\text{C} \leq T_J \leq +125^\circ\text{C}$ for the LM320-N.

(2) Regulation is measured at constant junction temperature. Changes in output voltage due to heating effects must be taken into account separately. To ensure constant junction temperature, low duty cycle, pulse testing is used. The LM120/LM320-N series does have low thermal feedback, improving line and load regulation. On all other tests, even though power dissipation is internally limited, electrical specifications apply only up to P_D .

(3) This specification applies over $-55^\circ\text{C} \leq T_J \leq +150^\circ\text{C}$ for the LM120 and $0^\circ\text{C} \leq T_J \leq +125^\circ\text{C}$ for the LM320-N.

LM120H-12 ELECTRICAL CHARACTERISTICS

Order Numbers		Metal Can Package			Units
		LM120H-12 (TO)			
Design Output Current (I_D)		0.2A			
Device Dissipation (P_D)		2W			
Parameter	Conditions ⁽¹⁾	Min	Typ	Max	
Output Voltage	$T_J = 25^\circ\text{C}$, $V_{IN} = 17\text{V}$, $I_{LOAD} = 5\text{ mA}$	-12.3	-12	-11.7	V
Line Regulation	$T_J = 25^\circ\text{C}$, $I_{LOAD} = 5\text{ mA}$, $V_{MIN} \leq V_{IN} \leq V_{MAX}$		4	10	mV
Input Voltage		-32		-14	V
Ripple Rejection	$f = 120\text{ Hz}$	56	80		dB
Load Regulation,	$T_J = 25^\circ\text{C}$, $V_{IN} = 17\text{V}$,		10	25	mV

(1) This specification applies over $-55^\circ\text{C} \leq T_J \leq +150^\circ\text{C}$ for the LM120 and $0^\circ\text{C} \leq T_J \leq +125^\circ\text{C}$ for the LM320-N.

LM120H-12 ELECTRICAL CHARACTERISTICS (continued)

Order Numbers		Metal Can Package			Units
		LM120H-12 (TO)			
Design Output Current (I _D)		0.2A			
Device Dissipation (P _D)		2W			
Parameter	Conditions ⁽¹⁾	Min	Typ	Max	
(2)	5 mA ≤ I _{LOAD} ≤ I _D				
Output Voltage, (1)	14.5V ≤ V _{IN} ≤ V _{MAX} , 5 mA ≤ I _{LOAD} ≤ I _D , P ≤ P _D	-12.5		-11.5	V
Quiescent Current	V _{MIN} ≤ V _{IN} ≤ V _{MAX}		2	4	mA
Quiescent Current Change	T _J = 25°C V _{MIN} ≤ V _{IN} ≤ V _{MAX} 5 mA ≤ I _{LOAD} ≤ I _D		0.05 0.03	0.4 0.4	mA mA
Output Noise Voltage	T _A = 25°C, C _L = 1 μF, I _L = 5 mA, V _{IN} = 17V, 10 Hz ≤ f ≤ 100 kHz		400		μV
Long Term Stability			12	120	mV
Thermal Resistance Junction to Case				(3)	°C/W
Junction to Ambient				(3)	°C/W

- (2) Regulation is measured at constant junction temperature. Changes in output voltage due to heating effects must be taken into account separately. To ensure constant junction temperature, low duty cycle, pulse testing is used. The LM120/LM320-N series does have low thermal feedback, improving line and load regulation. On all other tests, even though power dissipation is internally limited, electrical specifications apply only up to P_D.
- (3) Thermal resistance of typically 85°C/W (in 400 linear feet/min air flow), 224°C/W (in static air) junction to ambient, of typically 21°C/W junction to case.

LM320T-12 ELECTRICAL CHARACTERISTICS

Order Numbers		Power Plastic Package			Units
		LM320T-12 (TO-220)			
Design Output Current (I _D)		1A			
Device Dissipation (P _D)		15W			
Parameter	Conditions ⁽¹⁾	Min	Typ	Max	
Output Voltage	T _J = 25°C, V _{IN} = 17V, I _{LOAD} = 5 mA	-12.4	-12	-11.6	V
Line Regulation	T _J = 25°C, I _{LOAD} = 5 mA, V _{MIN} ≤ V _{IN} ≤ V _{MAX}		4	20	mV
Input Voltage		-32		-14.5	V
Ripple Rejection	f = 120 Hz	56	80		dB
Load Regulation, (2)	T _J = 25°C, V _{IN} = 17V, 5 mA ≤ I _{LOAD} ≤ I _D		30	80	mV
Output Voltage, (1)	14.5V ≤ V _{IN} ≤ V _{MAX} , 5 mA ≤ I _{LOAD} ≤ I _D , P ≤ P _D	-12.6		-11.4	V
Quiescent Current	V _{MIN} ≤ V _{IN} ≤ V _{MAX}		2	4	mA
Quiescent Current Change	T _J = 25°C V _{MIN} ≤ V _{IN} ≤ V _{MAX} 5 mA ≤ I _{LOAD} ≤ I _D		0.1 0.1	0.4 0.4	mA mA

- (1) This specification applies over -55°C ≤ T_J ≤ +150°C for the LM120 and 0°C ≤ T_J ≤ +125°C for the LM320-N.
- (2) Regulation is measured at constant junction temperature. Changes in output voltage due to heating effects must be taken into account separately. To ensure constant junction temperature, low duty cycle, pulse testing is used. The LM120/LM320-N series does have low thermal feedback, improving line and load regulation. On all other tests, even though power dissipation is internally limited, electrical specifications apply only up to P_D.

LM320T-12 ELECTRICAL CHARACTERISTICS (continued)

Order Numbers		Power Plastic Package			Units
		LM320T-12 (TO-220)			
Design Output Current (I_D)		1A			
Device Dissipation (P_D)		15W			
Parameter	Conditions ⁽¹⁾	Min	Typ	Max	
Output Noise Voltage	$T_A = 25^\circ\text{C}$, $C_L = 1\ \mu\text{F}$, $I_L = 5\ \text{mA}$, $V_{IN} = 17\text{V}$, $10\ \text{Hz} \leq f \leq 100\ \text{kHz}$		400		μV
Long Term Stability			24		mV
Thermal Resistance Junction to Case			4		$^\circ\text{C}/\text{W}$
Junction to Ambient			50		$^\circ\text{C}/\text{W}$

ABSOLUTE MAXIMUM RATINGS—15 VOLT REGULATORS ⁽¹⁾⁽²⁾

Power Dissipation	Internally Limited
Input Voltage	
LM120/LM320-N	-40V
LM320T	-35V
Input-Output Voltage Differential	30V
Junction Temperatures	⁽³⁾
Storage Temperature Range	-65 $^\circ\text{C}$ to +150 $^\circ\text{C}$
Lead Temperature (Soldering, 10 sec.)	300 $^\circ\text{C}$

(1) Refer to RETS120-15H drawing for LM120H-15 or RETS120-15K drawing for LM120K-15 military specifications.

(2) If Military/Aerospace specified devices are required, please contact the Texas Instruments Sales Office/Distributors for availability and specifications.

(3) This specification applies over $-55^\circ\text{C} \leq T_J \leq +150^\circ\text{C}$ for the LM120 and $0^\circ\text{C} \leq T_J \leq +125^\circ\text{C}$ for the LM320-N.

LM120K-15 AND LM320K-15 ELECTRICAL CHARACTERISTICS

Order Numbers		Metal Can Package						Units
		LM120K-15 (TO-3)			LM320K-15 (TO-3)			
Design Output Current (I_D)		1A						
Device Dissipation (P_D)		20W						
Parameter	Conditions ⁽¹⁾	Min	Typ	Max	Min	Typ	Max	
Output Voltage	$T_J = 25^\circ\text{C}$, $V_{IN} = 20\text{V}$, $I_{LOAD} = 5\ \text{mA}$	-15.3	-15	-14.7	-15.4	-15	-14.6	V
Line Regulation	$T_J = 25^\circ\text{C}$, $I_{LOAD} = 5\ \text{mA}$, $V_{MIN} \leq V_{IN} \leq V_{MAX}$		5	10		5	20	mV
Input Voltage		-35		-17	-35		-17	V
Ripple Rejection	$f = 120\ \text{Hz}$	56	80		56	80		dB
Load Regulation, ⁽²⁾	$T_J = 25^\circ\text{C}$, $V_{IN} = 20\text{V}$, $5\ \text{mA} \leq I_{LOAD} \leq I_D$		30	80		30	80	mV
Output Voltage, ⁽¹⁾	$17.5\text{V} \leq V_{IN} \leq V_{MAX}$, $5\ \text{mA} \leq I_{LOAD} \leq I_D$, $P \leq P_D$	-15.5		-14.5	-15.6		-14.4	V
Quiescent Current	$V_{MIN} \leq V_{IN} \leq V_{MAX}$		2	4		2	4	mA

(1) This specification applies over $-55^\circ\text{C} \leq T_J \leq +150^\circ\text{C}$ for the LM120 and $0^\circ\text{C} \leq T_J \leq +125^\circ\text{C}$ for the LM320-N.

(2) Regulation is measured at constant junction temperature. Changes in output voltage due to heating effects must be taken into account separately. To ensure constant junction temperature, low duty cycle, pulse testing is used. The LM120/LM320-N series does have low thermal feedback, improving line and load regulation. On all other tests, even though power dissipation is internally limited, electrical specifications apply only up to P_D .

LM120K-15 AND LM320K-15 ELECTRICAL CHARACTERISTICS (continued)

Order Numbers		Metal Can Package						Units
		LM120K-15 (TO-3)			LM320K-15 (TO-3)			
Design Output Current (I _D)		1A						
Device Dissipation (P _D)		20W						
Parameter	Conditions ⁽¹⁾	Min	Typ	Max	Min	Typ	Max	
Quiescent Current Change	T _J = 25°C							
	V _{MIN} ≤ V _{IN} ≤ V _{MAX} 5 mA ≤ I _{LOAD} ≤ I _D		0.1 0.1	0.4 0.4		0.1 0.1	0.4 0.4	
Output Noise Voltage	T _A = 25°C, C _L = 1 μF, I _L = 5 mA, V _{IN} = 20V, 10 Hz ≤ f ≤ 100 kHz		400			400		
Long Term Stability			15	150		15	150	
Thermal Resistance								
Junction to Case				3			3	
Junction to Ambient				35			35	

LM120H-15 ELECTRICAL CHARACTERISTICS

Order Numbers		Metal Can Package			Units
		LM120H-15 (TO)			
Design Output Current (I _D)		0.2A			
Device Dissipation (P _D)		2W			
Parameter	Conditions ⁽¹⁾	Min	Typ	Max	
Output Voltage	T _J = 25°C, V _{IN} = 20V, I _{LOAD} = 5 mA	-15.3	-15	-14.7	
Line Regulation	T _J = 25°C, I _{LOAD} = 5 mA, V _{MIN} ≤ V _{IN} ≤ V _{MAX}		5	10	
Input Voltage		-35		-17	
Ripple Rejection	f = 120 Hz	56	80		
Load Regulation, ⁽²⁾	T _J = 25°C, V _{IN} = 20V, 5 mA ≤ I _{LOAD} ≤ I _D		10	25	
Output Voltage, ⁽¹⁾	17.5V ≤ V _{IN} ≤ V _{MAX} , 5 mA ≤ I _{LOAD} ≤ I _D , P ≤ P _D	-15.5		-14.5	
Quiescent Current	V _{MIN} ≤ V _{IN} ≤ V _{MAX}		2	4	
Quiescent Current Change	T _J = 25°C				
	V _{MIN} ≤ V _{IN} ≤ V _{MAX} 5 mA ≤ I _{LOAD} ≤ I _D		0.05 0.03	0.4 0.4	
Output Noise Voltage	T _A = 25°C, C _L = 1 μF, I _L = 5 mA, V _{IN} = 20V, 10 Hz ≤ f ≤ 100 kHz		400		
Long Term Stability			15	150	
Thermal Resistance					
Junction to Case				⁽³⁾	
Junction to Ambient				⁽³⁾	

(1) This specification applies over -55°C ≤ T_J ≤ +150°C for the LM120 and 0°C ≤ T_J ≤ +125°C for the LM320-N.

(2) Regulation is measured at constant junction temperature. Changes in output voltage due to heating effects must be taken into account separately. To ensure constant junction temperature, low duty cycle, pulse testing is used. The LM120/LM320-N series does have low thermal feedback, improving line and load regulation. On all other tests, even though power dissipation is internally limited, electrical specifications apply only up to P_D.

(3) Thermal resistance of typically 85°C/W (in 400 linear feet/min air flow), 224°C/W (in static air) junction to ambient, of typically 21°C/W junction to case.

LM320T-15 ELECTRICAL CHARACTERISTICS

Order Numbers		Power Plastic Package			Units
		LM320T-15 (TO-220)			
Design Output Current (I_D)		1A			
Device Dissipation (P_D)		15W			
Parameter	Conditions ⁽¹⁾	Min	Typ	Max	
Output Voltage	$T_J = 25^\circ\text{C}$, $V_{IN} = 20\text{V}$, $I_{LOAD} = 5\text{ mA}$	-15.5	-15	-14.5	V
Line Regulation	$T_J = 25^\circ\text{C}$, $I_{LOAD} = 5\text{ mA}$, $V_{MIN} \leq V_{IN} \leq V_{MAX}$		5	20	mV
Input Voltage		-35		-17.5	V
Ripple Rejection	$f = 120\text{ Hz}$	56	80		dB
Load Regulation, ⁽²⁾	$T_J = 25^\circ\text{C}$, $V_{IN} = 20\text{V}$, $5\text{ mA} \leq I_{LOAD} \leq I_D$		30	80	mV
Output Voltage, ⁽¹⁾	$17.5\text{V} \leq V_{IN} \leq V_{MAX}$, $5\text{ mA} \leq I_{LOAD} \leq I_D$, $P \leq P_D$	-15.7		-14.3	V
Quiescent Current	$V_{MIN} \leq V_{IN} \leq V_{MAX}$		2	4	mA
Quiescent Current Change	$T_J = 25^\circ\text{C}$ $V_{MIN} \leq V_{IN} \leq V_{MAX}$ $5\text{ mA} \leq I_{LOAD} \leq I_D$		0.1 0.1	0.4 0.4	mA mA
Output Noise Voltage	$T_A = 25^\circ\text{C}$, $C_L = 1\ \mu\text{F}$, $I_L = 5\text{ mA}$, $V_{IN} = 20\text{V}$, $10\text{ Hz} \leq f \leq 100\text{ kHz}$		400		μV
Long Term Stability			30		mV
Thermal Resistance					
Junction to Case			4		$^\circ\text{C/W}$
Junction to Ambient			50		$^\circ\text{C/W}$

(1) This specification applies over $-55^\circ\text{C} \leq T_J \leq +150^\circ\text{C}$ for the LM120 and $0^\circ\text{C} \leq T_J \leq +125^\circ\text{C}$ for the LM320-N.

(2) Regulation is measured at constant junction temperature. Changes in output voltage due to heating effects must be taken into account separately. To ensure constant junction temperature, low duty cycle, pulse testing is used. The LM120/LM320-N series does have low thermal feedback, improving line and load regulation. On all other tests, even though power dissipation is internally limited, electrical specifications apply only up to P_D .

TYPICAL PERFORMANCE CHARACTERISTICS

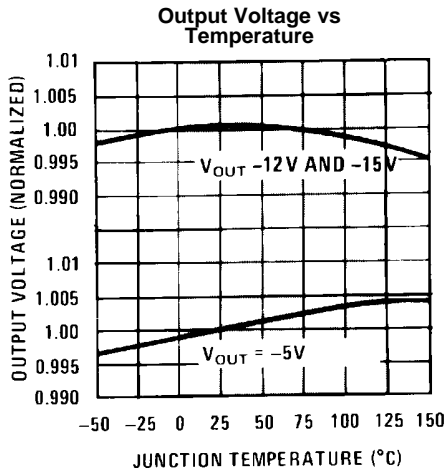

Figure 3.

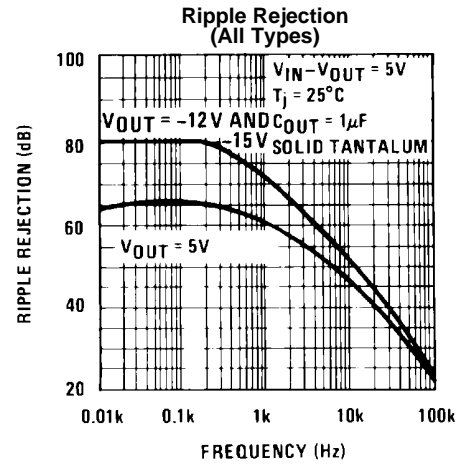

Figure 4.

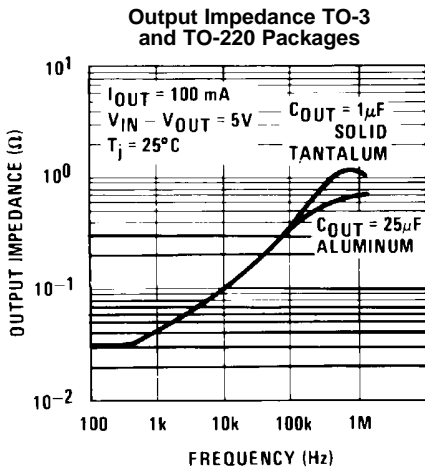

Figure 5.

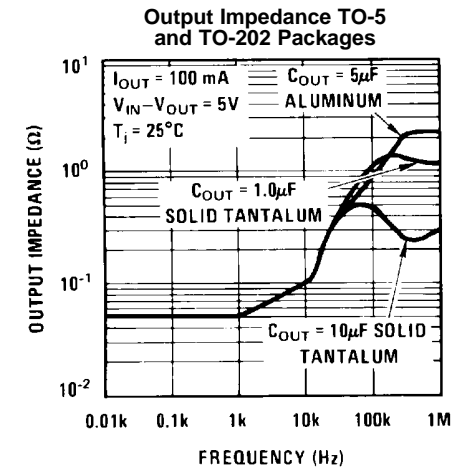

Figure 6.

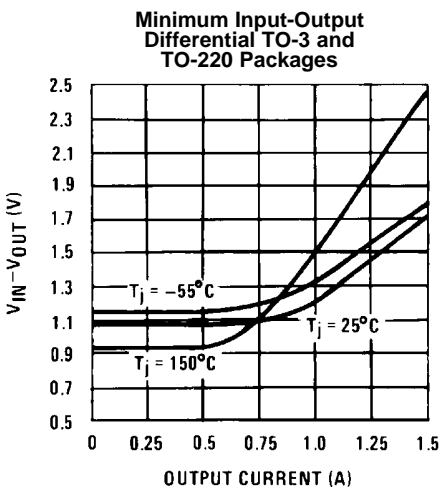

Figure 7.

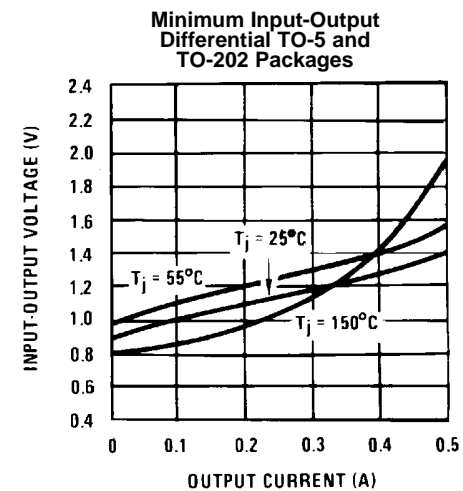

Figure 8.

TYPICAL PERFORMANCE CHARACTERISTICS (continued)

Quiescent Current vs Input Voltage

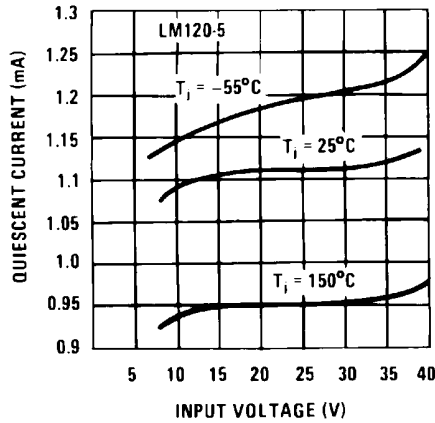

Figure 9.

Quiescent Current vs Load Current

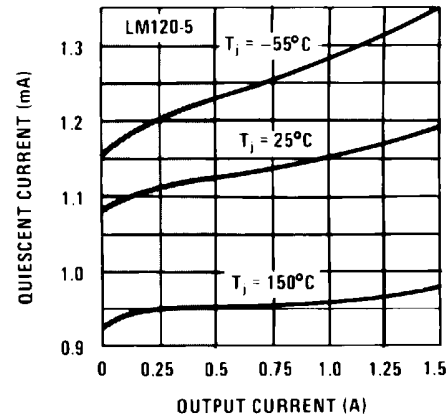

Figure 10.

Maximum Average Power Dissipation (TO-3)

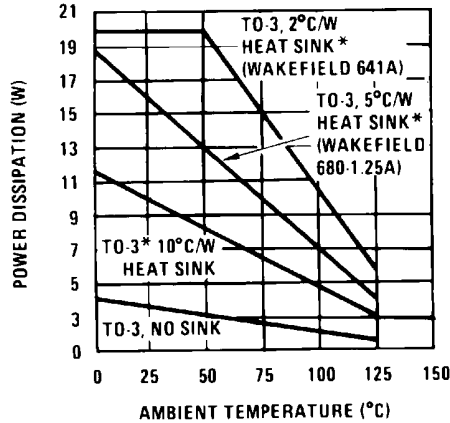

Figure 11.

Maximum Average Power Dissipation (TO-5)

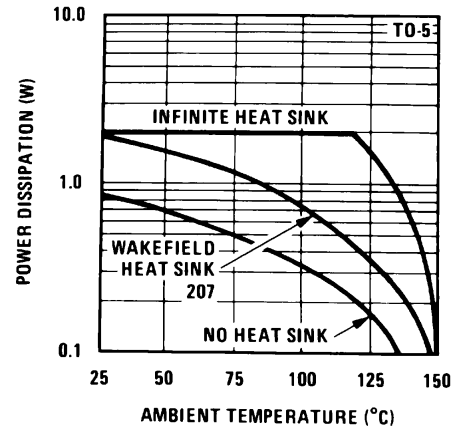

Figure 12.

*These curves for LM120. Derate 25°C further for LM320-N.

Maximum Average Power Dissipation (TO-202)

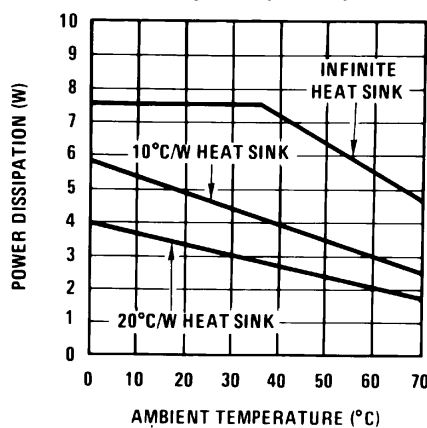

Figure 13.

Maximum Average Power Dissipation (TO-220)

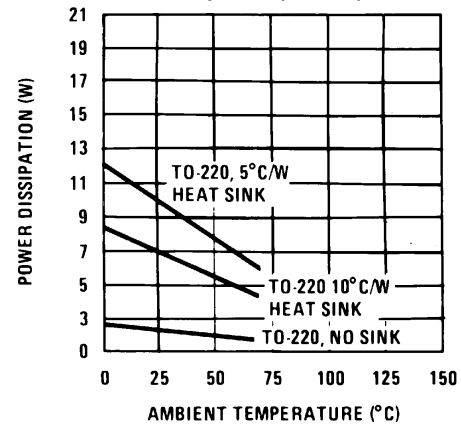
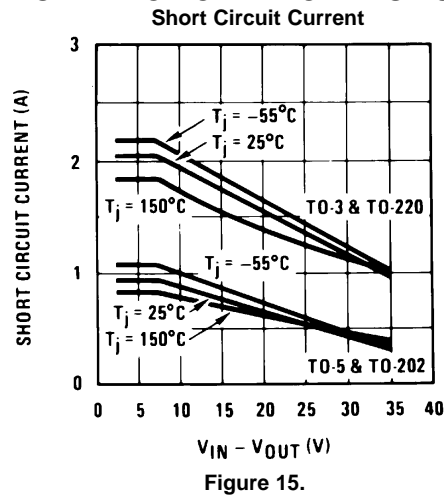
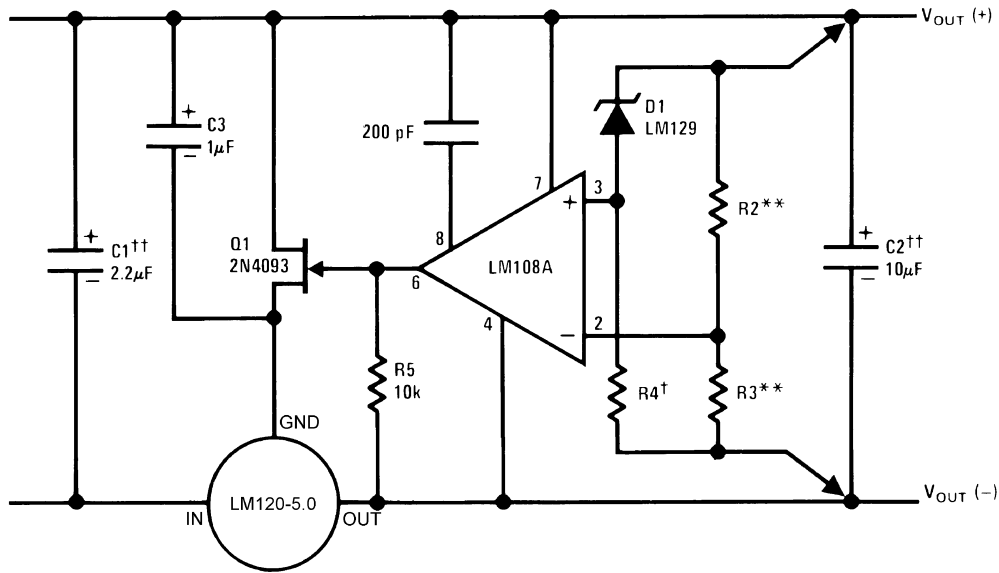

Figure 14.

TYPICAL PERFORMANCE CHARACTERISTICS (continued)



TYPICAL APPLICATIONS



Lead and line regulation — 0.01% temperature stability — 0.2%

†Determines Zener current.

††Solid tantalum.

An LM120-12 or LM120-15 may be used to permit higher input voltages, but the regulated output voltage must be at least -15V when using the LM120-12 and -18V for the LM120-15.

**Select resistors to set output voltage. 2 ppm/°C tracking suggested.

Figure 16. High Stability 1 Amp Regulator

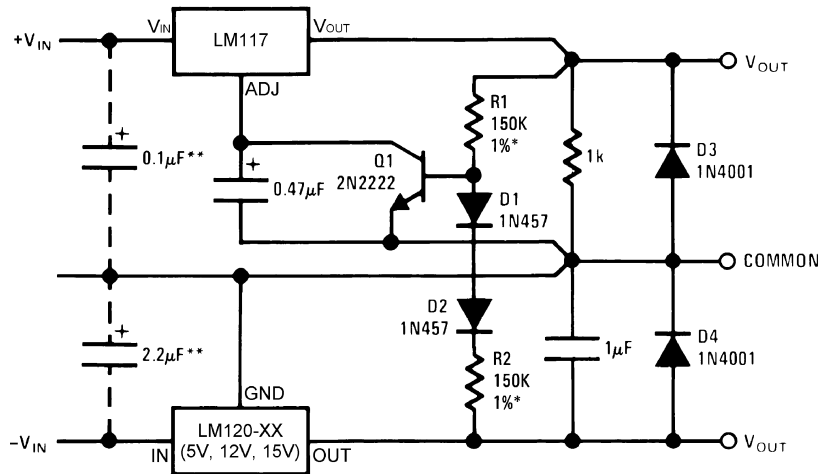

*Resistor tolerance of R1 and R2 determine matching of (+) and (-) inputs.

**Necessary only if raw supply capacitors are more than 3" from regulators

An LM3086N array may substitute for Q1, D1 and D2 for better stability and tracking. In the array diode transistors Q5 and Q4 (in parallel) make up D2; similarly, Q1 and Q2 become D1 and Q3 replaces the 2N2222.

Figure 17. Wide Range Tracking Regulator

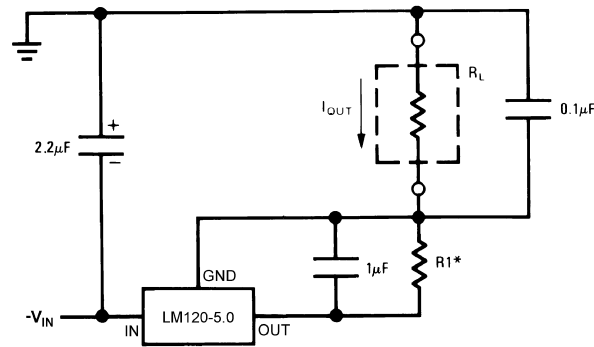

$$I_{OUT} = 1 \text{ mA} + \frac{5.0\text{V}}{R_1}$$

Figure 18. Current Source

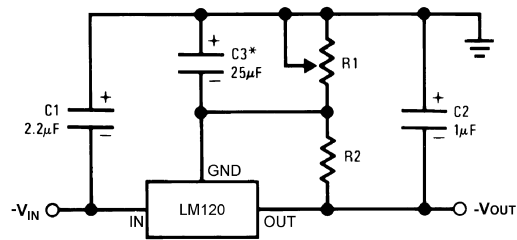

SELECT R2 AS FOLLOWS:

LM120-5 300Ω

LM120-12 750Ω

LM120-15 1k

$$V_{OUT} = V_{SET} \frac{R_1 + R_2}{R_2}$$

*C3 optional. Improves transient response and ripple rejection.

Figure 19. Variable Output Current Source

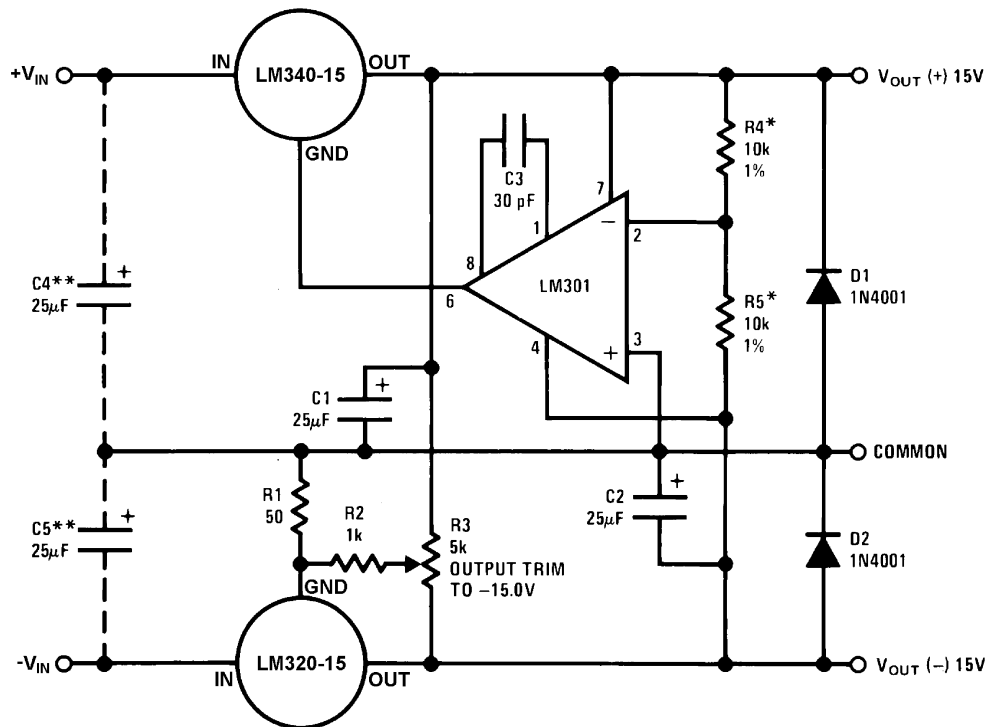

See [Performance \(Typical\)](#)

*Resistor tolerance of R4 and R5 determine matching of (+) and (-) outputs.

**Necessary only if raw supply filter capacitors are more than 2 inches from regulators.

Figure 20. ±15V, 1 Amp Tracking Regulators

Performance (Typical)

Load Regulation at $\Delta I_L = 1A$	10 mV	1 mV
Output Ripple, $C_{IN} = 3000 \mu F$, $I_L = 1A$	100 μV_{rms}	100 μV_{rms}
Temperature Stability	+50 mV	+50 mV
Output Noise $10 \text{ Hz} \leq f \leq 10 \text{ kHz}$	150 μV_{rms}	150 μV_{rms}

Light Controllers Using Silicon Photo Cells

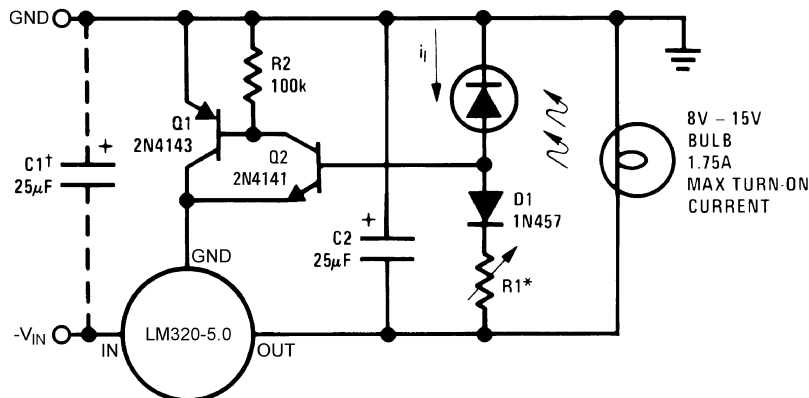

*Lamp brightness increases until $i_l = 5V/R1$ (i_l can be set as low as 1 μA).

†Necessary only if raw supply filter capacitor is more than 2 inches from LM320MP.

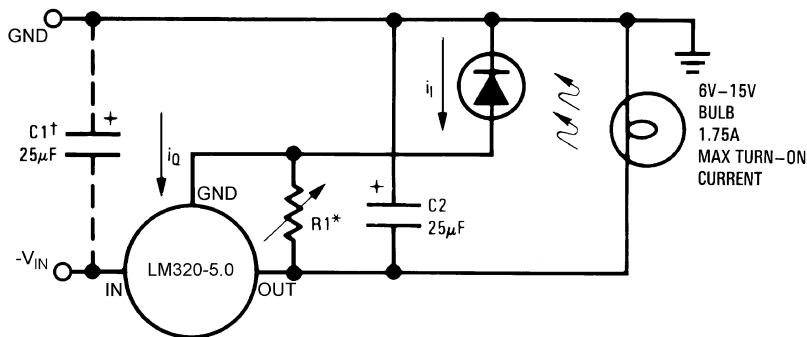

*Lamp brightness increases until $i_I = i_Q (1 \text{ mA}) + 5V/R1$.

†Necessary only if raw supply filter capacitor is more than 2 inches from LM320-N.

Connection Diagram

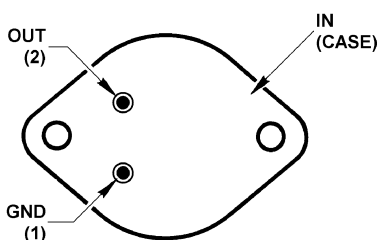

Figure 21. Steel Metal Can Package TO-3 (NDS) (Bottom View)

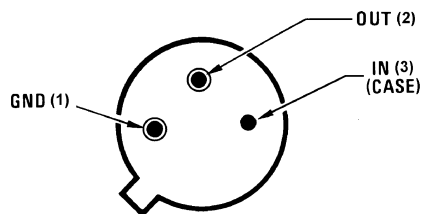

Figure 22. Metal Can Package TO (NDT) (Bottom View)

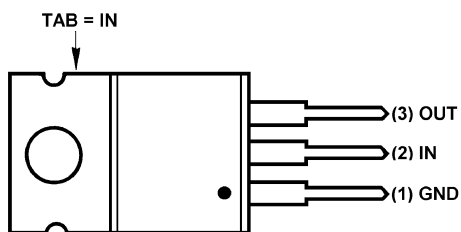

Figure 23. Power Package TO-220 (NDE) (Front View)

Schematic Diagrams

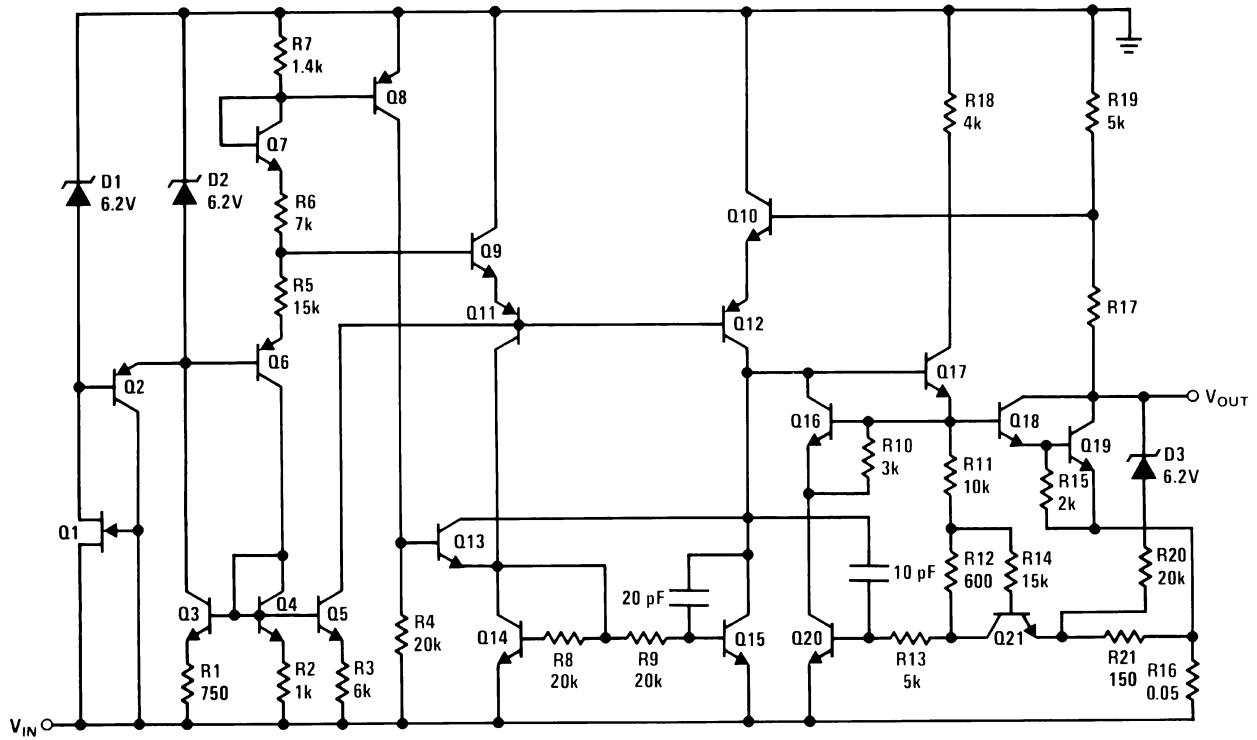

Figure 24. -5V

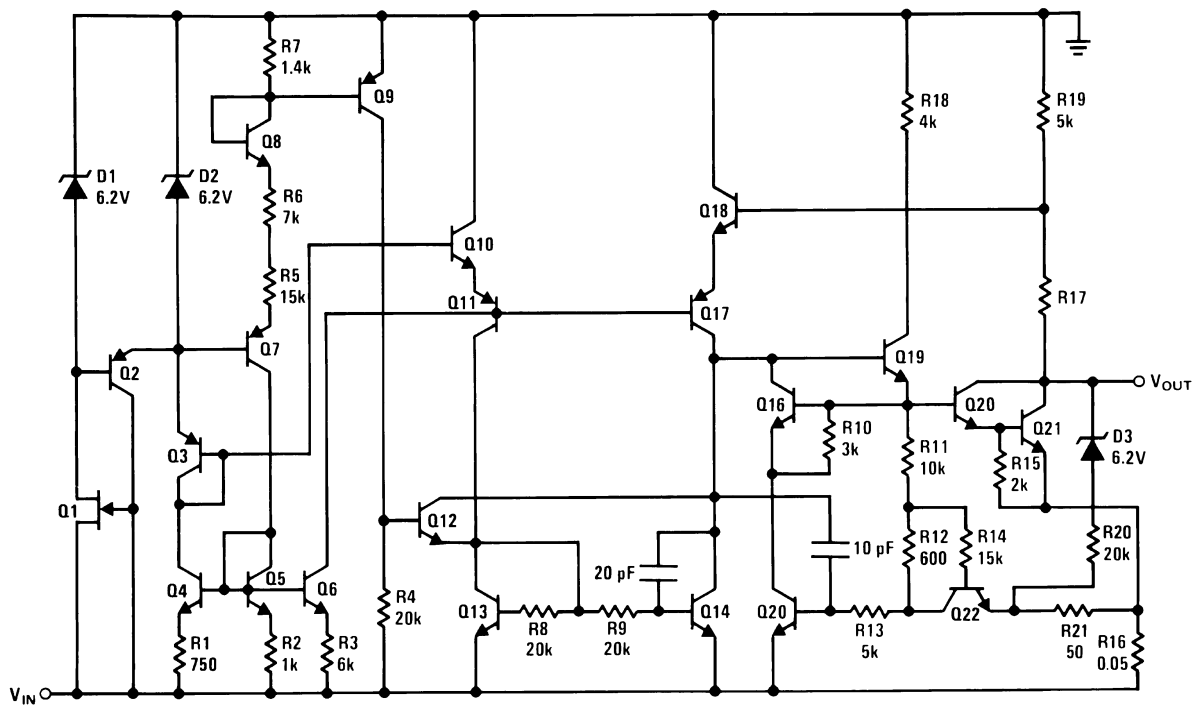

Figure 25. -12V and -15V

REVISION HISTORY

Changes from Revision B (April 2013) to Revision C	Page
<hr/> <ul style="list-style-type: none">• Changed layout of National Data Sheet to TI format	<hr/> 16

PACKAGING INFORMATION

Orderable Device	Status (1)	Package Type	Package Drawing	Pins	Package Qty	Eco Plan (2)	Lead finish/ Ball material (6)	MSL Peak Temp (3)	Op Temp (°C)	Device Marking (4/5)	Samples
LM120H-12	ACTIVE	TO	NDT	3	500	RoHS & Green	AU	Level-1-NA-UNLIM	-55 to 150	(LM120H-12P+, LM120H-12P+)	Samples
LM120H-12/NOPB	ACTIVE	TO	NDT	3	500	RoHS & Green	AU	Level-1-NA-UNLIM	-55 to 150	(LM120H-12P+, LM120H-12P+)	Samples
LM120H-15	ACTIVE	TO	NDT	3	500	RoHS & Green	AU	Level-1-NA-UNLIM	-55 to 150	(LM120H-15P+, LM120H-15P+)	Samples
LM120H-15/NOPB	ACTIVE	TO	NDT	3	500	RoHS & Green	AU	Level-1-NA-UNLIM	-55 to 150	(LM120H-15P+, LM120H-15P+)	Samples
LM120H-5.0	ACTIVE	TO	NDT	3	500	RoHS & Green	AU	Level-1-NA-UNLIM	-55 to 150	(LM120H-5.0P+, LM120H-5.0P+)	Samples
LM120H-5.0/NOPB	ACTIVE	TO	NDT	3	500	RoHS & Green	AU	Level-1-NA-UNLIM	-55 to 150	(LM120H-5.0P+, LM120H-5.0P+)	Samples
LM320T-15	NRND	TO-220	NDE	3	45	Non-RoHS & Green	Call TI	Level-1-NA-UNLIM	0 to 125	LM320T-15 P+	
LM320T-15/NOPB	ACTIVE	TO-220	NDE	3	45	RoHS & Green	SN	Level-1-NA-UNLIM	0 to 125	LM320T-15 P+	Samples

(1) The marketing status values are defined as follows:

ACTIVE: Product device recommended for new designs.

LIFEBUY: TI has announced that the device will be discontinued, and a lifetime-buy period is in effect.

NRND: Not recommended for new designs. Device is in production to support existing customers, but TI does not recommend using this part in a new design.

PREVIEW: Device has been announced but is not in production. Samples may or may not be available.

OBSELETE: TI has discontinued the production of the device.

(2) **RoHS:** TI defines "RoHS" to mean semiconductor products that are compliant with the current EU RoHS requirements for all 10 RoHS substances, including the requirement that RoHS substance do not exceed 0.1% by weight in homogeneous materials. Where designed to be soldered at high temperatures, "RoHS" products are suitable for use in specified lead-free processes. TI may reference these types of products as "Pb-Free".

RoHS Exempt: TI defines "RoHS Exempt" to mean products that contain lead but are compliant with EU RoHS pursuant to a specific EU RoHS exemption.

Green: TI defines "Green" to mean the content of Chlorine (Cl) and Bromine (Br) based flame retardants meet JS709B low halogen requirements of <=1000ppm threshold. Antimony trioxide based flame retardants must also meet the <=1000ppm threshold requirement.

(3) MSL, Peak Temp. - The Moisture Sensitivity Level rating according to the JEDEC industry standard classifications, and peak solder temperature.

(4) There may be additional marking, which relates to the logo, the lot trace code information, or the environmental category on the device.

⁽⁵⁾ Multiple Device Markings will be inside parentheses. Only one Device Marking contained in parentheses and separated by a "~" will appear on a device. If a line is indented then it is a continuation of the previous line and the two combined represent the entire Device Marking for that device.

⁽⁶⁾ Lead finish/Ball material - Orderable Devices may have multiple material finish options. Finish options are separated by a vertical ruled line. Lead finish/Ball material values may wrap to two lines if the finish value exceeds the maximum column width.

Important Information and Disclaimer: The information provided on this page represents TI's knowledge and belief as of the date that it is provided. TI bases its knowledge and belief on information provided by third parties, and makes no representation or warranty as to the accuracy of such information. Efforts are underway to better integrate information from third parties. TI has taken and continues to take reasonable steps to provide representative and accurate information but may not have conducted destructive testing or chemical analysis on incoming materials and chemicals. TI and TI suppliers consider certain information to be proprietary, and thus CAS numbers and other limited information may not be available for release.

In no event shall TI's liability arising out of such information exceed the total purchase price of the TI part(s) at issue in this document sold by TI to Customer on an annual basis.

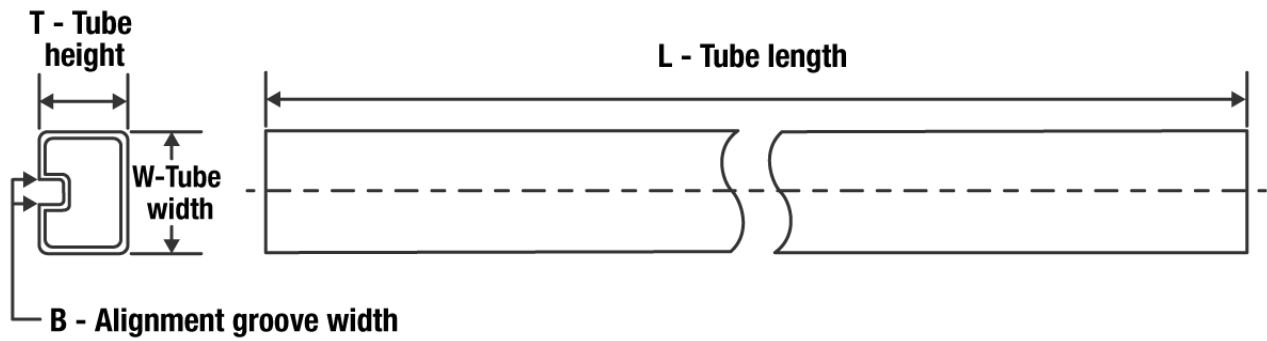
TUBE

*All dimensions are nominal

Device	Package Name	Package Type	Pins	SPQ	L (mm)	W (mm)	T (μm)	B (mm)
LM320T-15	NDE	TO-220	3	45	502	33	6985	4.06
LM320T-15	NDE	TO-220	3	45	502	33	6985	4.06
LM320T-15/NOPB	NDE	TO-220	3	45	502	33	6985	4.06

NDT0003A

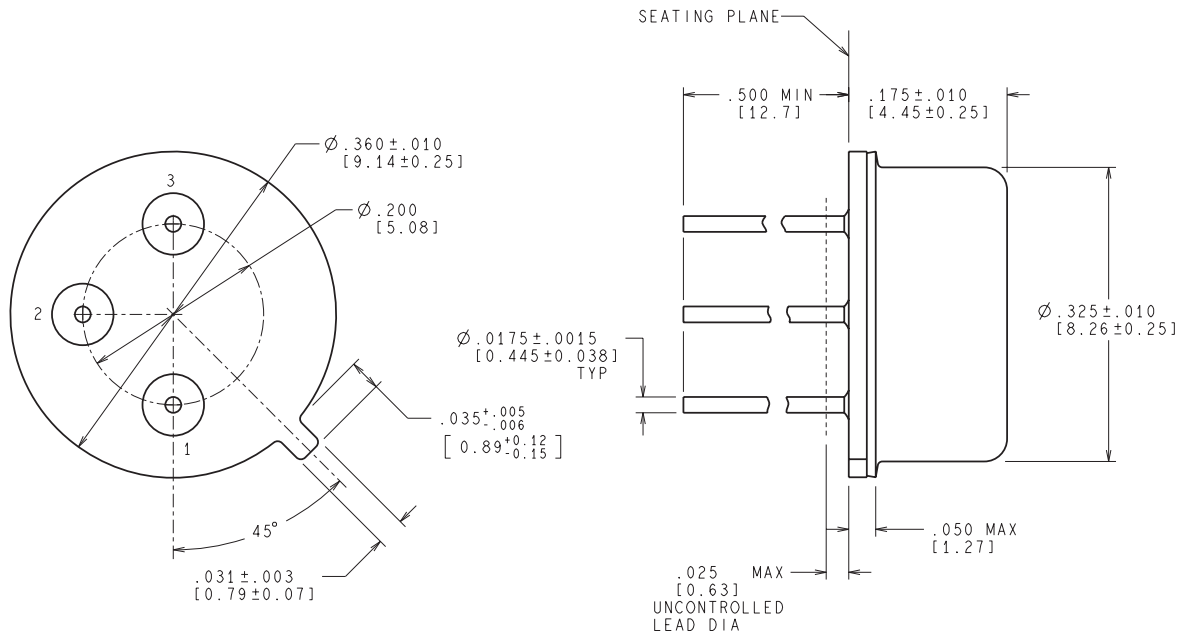

CONTROLLING DIMENSION IS INCH
VALUES IN [] ARE MILLIMETERS

MIL-PRF-38535
CONFIGURATION CONTROL

H03A (Rev D)

NDE0003B

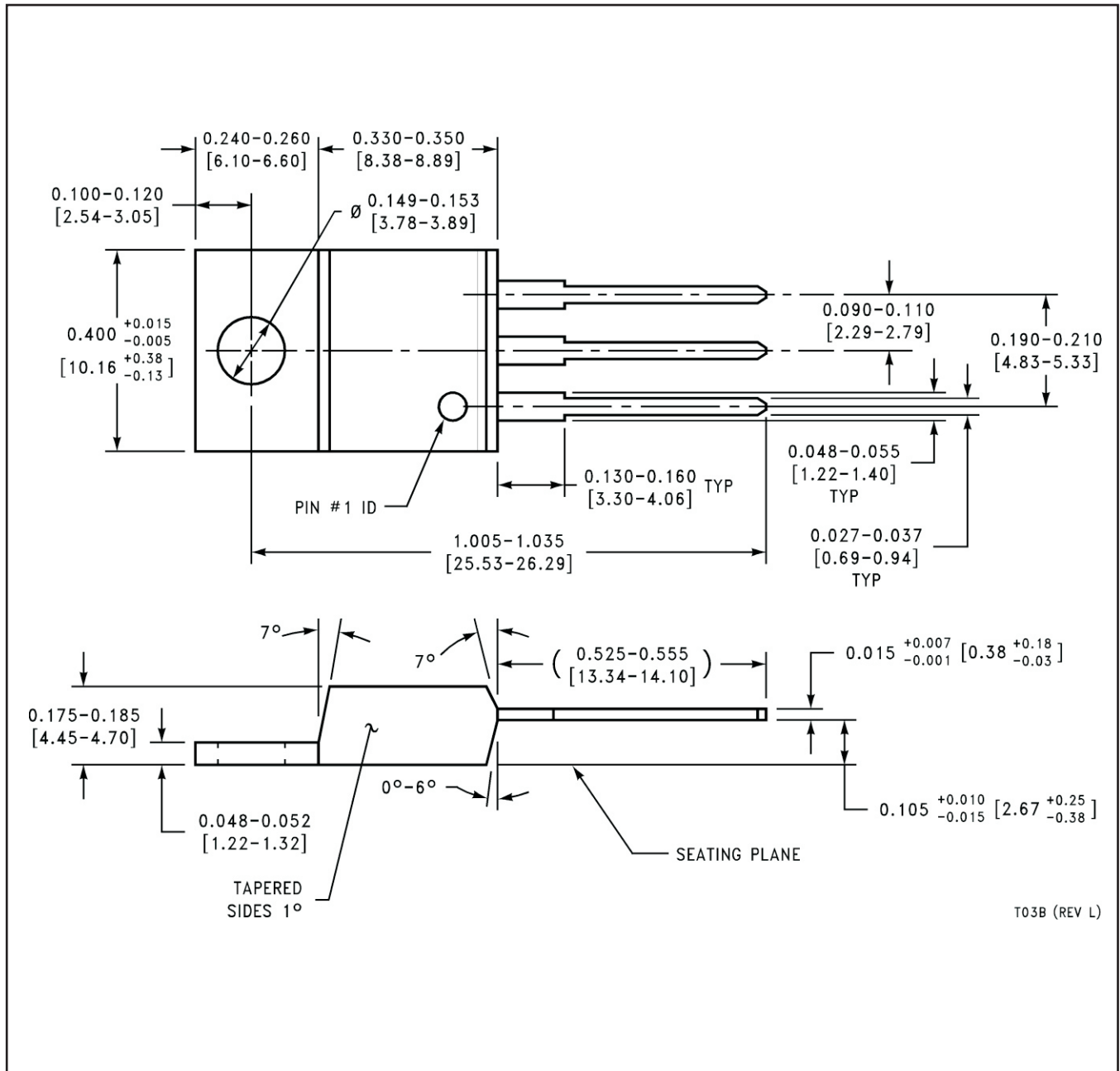

IMPORTANT NOTICE AND DISCLAIMER

TI PROVIDES TECHNICAL AND RELIABILITY DATA (INCLUDING DATA SHEETS), DESIGN RESOURCES (INCLUDING REFERENCE DESIGNS), APPLICATION OR OTHER DESIGN ADVICE, WEB TOOLS, SAFETY INFORMATION, AND OTHER RESOURCES "AS IS" AND WITH ALL FAULTS, AND DISCLAIMS ALL WARRANTIES, EXPRESS AND IMPLIED, INCLUDING WITHOUT LIMITATION ANY IMPLIED WARRANTIES OF MERCHANTABILITY, FITNESS FOR A PARTICULAR PURPOSE OR NON-INFRINGEMENT OF THIRD PARTY INTELLECTUAL PROPERTY RIGHTS.

These resources are intended for skilled developers designing with TI products. You are solely responsible for (1) selecting the appropriate TI products for your application, (2) designing, validating and testing your application, and (3) ensuring your application meets applicable standards, and any other safety, security, regulatory or other requirements.

These resources are subject to change without notice. TI grants you permission to use these resources only for development of an application that uses the TI products described in the resource. Other reproduction and display of these resources is prohibited. No license is granted to any other TI intellectual property right or to any third party intellectual property right. TI disclaims responsibility for, and you will fully indemnify TI and its representatives against, any claims, damages, costs, losses, and liabilities arising out of your use of these resources.

TI's products are provided subject to [TI's Terms of Sale](#) or other applicable terms available either on ti.com or provided in conjunction with such TI products. TI's provision of these resources does not expand or otherwise alter TI's applicable warranties or warranty disclaimers for TI products.

TI objects to and rejects any additional or different terms you may have proposed.

Mailing Address: Texas Instruments, Post Office Box 655303, Dallas, Texas 75265
Copyright © 2022, Texas Instruments Incorporated