

LM185QML Adjustable Micropower Voltage References

Check for Samples: [LM185QML](#)

FEATURES

- Adjustable from 1.24V to 5.30V
- Operating Current of 10 μ A to 20mA
- 1 Ω Dynamic Impedance
- Low Temperature Coefficient

DESCRIPTION

The LM185 are micropower 3-terminal adjustable band-gap voltage reference diodes. Operating from 1.24 to 5.3V and over a 10 μ A to 20mA current range, they feature exceptionally low dynamic impedance and good temperature stability. On-chip trimming is used to provide tight voltage tolerance. Since the LM185 band-gap reference uses only transistors and resistors, low noise and good long-term stability result.

Careful design of the LM185 has made the device tolerant of capacitive loading, making it easy to use in almost any reference application. The wide dynamic operating range allows its use with widely varying supplies with excellent regulation.

The extremely low power drain of the LM185 makes it useful for micropower circuitry. This voltage reference can be used to make portable meters, regulators or general purpose analog circuitry with battery life approaching shelf life. Further, the wide operating current allows it to replace older references with a tighter tolerance part.

Connection Diagrams

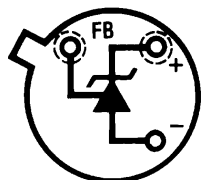

Figure 1. PFM Metal Can Package (Bottom View)
See Package Number NDV0003H

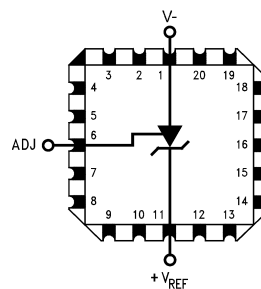

Figure 2. 20-Leadless Chip Carrier (Top View)
See Package Number NAJ0020A

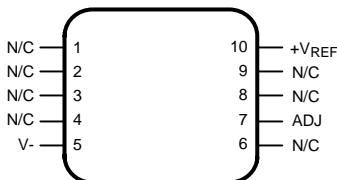

Figure 3. 10-Lead CLGA (Top View)
See Package Number NAC0010A



Please be aware that an important notice concerning availability, standard warranty, and use in critical applications of Texas Instruments semiconductor products and disclaimers thereto appears at the end of this data sheet.

All trademarks are the property of their respective owners.

Block Diagram

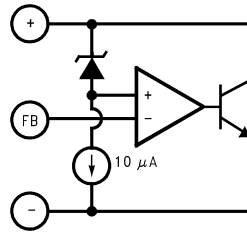

Schematic Diagram

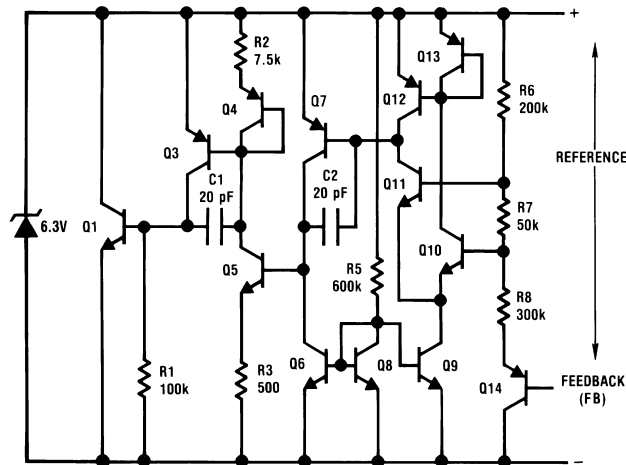

These devices have limited built-in ESD protection. The leads should be shorted together or the device placed in conductive foam during storage or handling to prevent electrostatic damage to the MOS gates.

Absolute Maximum Ratings⁽¹⁾

Reverse Current		30mA	
Forward Current		10mA	
Operating Temperature Range		-55°C ≤ T _A ≤ 125°C	
Storage Temperature		-55°C ≤ T _A ≤ 150°C	
Maximum Junction Temperature T _{Jmax}		150°C	
Lead Temperature (soldering, 10 seconds)		300°C	
Thermal Resistance	θ _{JA}	LCCC Package (Still Air)	100°C/W
		LCCC Package (500LF/Min Air flow)	73°C/W
		Metal Can Package (Still Air)	300°C/W
		Metal Can Package (500LF/Min Air flow)	139°C/W
		CLGA Package (Still Air)	194°C/W
		CLGA Package (500LF/Min Air flow)	128°C/W
	θ _{JC}	LCCC Package	25°C/W
		Metal Can Package	57°C/W
CLGA Package		23°C/W	
Package Weight (Typical)	LCCC Package	TBD	
	Metal Can Package	TBD	
	CLGA Package	210mg	
ESD Tolerance ⁽²⁾		500V	

- (1) Absolute Maximum Ratings are limits beyond which damage to the device may occur. Operating Ratings are conditions under which operation of the device is intended to be functional. For guaranteed specifications and test conditions, see the Electrical Characteristics.
- (2) Human body model, 1.5 kΩ in series with 100 pF.

**Table 1. Quality Conformance Inspection
Mil-Std-883, Method 5005 - Group A**

Subgroup	Description	Temp °C
1	Static tests at	25
2	Static tests at	125
3	Static tests at	-55
4	Dynamic tests at	25
5	Dynamic tests at	125
6	Dynamic tests at	-55
7	Functional tests at	25
8A	Functional tests at	125
8B	Functional tests at	-55
9	Switching tests at	25
10	Switching tests at	125
11	Switching tests at	-55
12	Settling time at	25
13	Settling time at	125
14	Settling time at	-55

LM185B Electrical Characteristics DC Parameters

Symbol	Parameter	Conditions	Notes	Min	Max	Unit	Sub-groups
V_{Ref}	Reference Voltage	$I_R = 100\mu A$		1.228	1.252	V	1
				1.215	1.255	V	2, 3
		$I_R = 9\mu A$		1.228	1.252	V	1
		$I_R = 10\mu A$		1.215	1.255	V	2, 3
		$I_R = 1mA$		1.228	1.252	V	1
				1.215	1.255	V	2, 3
		$I_R = 20mA$		1.228	1.252	V	1
				1.215	1.255	V	2, 3
		$V_R = 5.3V, I_R = 100\mu A$		1.228	1.252	V	1
				1.215	1.255	V	2, 3
		$V_R = 5.3V, I_R = 45\mu A$		1.288	1.252	V	1
		$V_R = 5.3V, I_R = 50\mu A$		1.215	1.255	V	2, 3
		$V_R = 5.3V, I_R = 1.0mA$		1.288	1.252	V	1
				1.215	1.255	V	2, 3
$V_R = 5.3V, I_R = 20mA$		1.288	1.252	V	1		
		1.215	1.255	V	2, 3		
$\Delta V_{Ref}/\Delta I_R$	Reference Voltage Change with Current	$9\mu A \leq I_R \leq 1mA$			1.0	mV	1
		$10\mu A \leq I_R \leq 1mA$			1.5	mV	2, 3
		$1mA \leq I_R \leq 20mA$			10	mV	1
					20	mV	2, 3
		$V_R = 5.3V, 45\mu A \leq I_R \leq 1mA$			1.0	mV	1
		$V_R = 5.3V, 50\mu A \leq I_R \leq 1mA$			1.5	mV	2, 3
		$V_R = 5.3V, 1mA \leq I_R \leq 20mA$			10	mV	1
			20	mV	2, 3		
$\Delta V_{Ref}/\Delta V_O$	Reference Voltage Change with Output Voltage	$V_R = 5.3V, I_R = 100\mu A$			3.0	mV	1
					6.0	mV	2, 3
I_F	Feedback Current	$I_R = 9\mu A$			20	nA	1
					25	nA	2, 3
		$I_R = 10\mu A$			20	nA	1
					25	nA	2, 3
		$V_R = 5.3V, I_R = 45\mu A$			20	nA	1
		$V_R = 5.3V, I_R = 50\mu A$			25	nA	2, 3
		$V_R = 5.3V, I_R = 20mA$			20	nA	1
			25	nA	2, 3		
I_C	Minimum Operating Current	$V_R = V_{Ref}$	See ⁽¹⁾		9.0	μA	1
			See ⁽¹⁾		10	μA	2, 3
		$V_R = 5.3V$	See ⁽¹⁾		45	μA	1
			See ⁽¹⁾		50	μA	2, 3

(1) Functional test.

LM185BY Electrical Characteristics DC Parameters

Symbol	Parameter	Conditions	Notes	Min	Max	Unit	Sub-groups
V _{Ref}	Reference Voltage	I _R = 100μA		1.228	1.252	V	1
				1.215	1.255	V	2, 3
		I _R = 9μA		1.228	1.252	V	1
		I _R = 10μA		1.215	1.255	V	2, 3
		I _R = 1mA		1.228	1.252	V	1
				1.215	1.255	V	2, 3
		I _R = 20mA		1.228	1.252	V	1
				1.215	1.255	V	2, 3
		V _R = 5.3V, I _R = 100μA		1.228	1.252	V	1
				1.215	1.255	V	2, 3
		V _R = 5.3V, I _R = 45μA		1.288	1.252	V	1
		V _R = 5.3V, I _R = 50μA		1.215	1.255	V	2, 3
		V _R = 5.3V, I _R = 1.0mA		1.288	1.252	V	1
	1.215		1.255	V	2, 3		
V _R = 5.3V, I _R = 20mA		1.288	1.252	V	1		
		1.215	1.255	V	2, 3		
ΔV _{Ref} /ΔI _R	Reference Voltage Change with Current	9μA ≤ I _R ≤ 1mA			1.0	mV	1
		10μA ≤ I _R ≤ 1mA			1.5	mV	2, 3
		1mA ≤ I _R ≤ 20mA			10	mV	1
					20	mV	2, 3
		V _R = 5.3V, 45μA ≤ I _R ≤ 1mA			1.0	mV	1
		V _R = 5.3V, 50μA ≤ I _R ≤ 1mA			1.5	mV	2, 3
		V _R = 5.3V, 1mA ≤ I _R ≤ 20mA			10	mV	1
			20	mV	2, 3		
ΔV _{Ref} / ΔV _O	Reference Voltage Change with Output Voltage	V _R = 5.3V, I _R = 100μA			3.0	mV	1
					6.0	mV	2, 3
I _F	Feedback Current	I _R = 9μA			20	nA	1
		I _R = 10μA			25	nA	2, 3
		I _R = 20mA			20	nA	1
					25	nA	2, 3
		V _R = 5.3V, I _R = 45μA			20	nA	1
		V _R = 5.3V, I _R = 50μA			25	nA	2, 3
		V _R = 5.3V, I _R = 20mA			20	nA	1
			25	nA	2, 3		
I _C	Minimum Operating Current	V _R = V _{Ref}	See ⁽¹⁾		9.0	μA	1
			See ⁽¹⁾		10	μA	2, 3
		V _R = 5.3V	See ⁽¹⁾		45	μA	1
			See ⁽¹⁾		50	μA	2, 3
T _C	Temperature Coefficient		See ⁽²⁾		50	PPM/°C	1, 2, 3

(1) Functional test.

(2) The average temperature coefficient is defined as the maximum deviation of reference voltage, at all measured temperatures between the operating T_{Min} & T_{Max}, divided by (T_{Max} - T_{Min}). The measured temperatures (T_{Measured}) are -55°C, 25°C, & 125°C or ΔV_{Ref} / (T_{Max} - T_{Min})

Typical Performance Characteristics

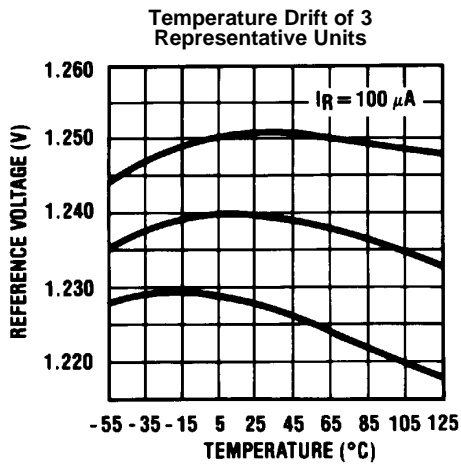

Figure 4.

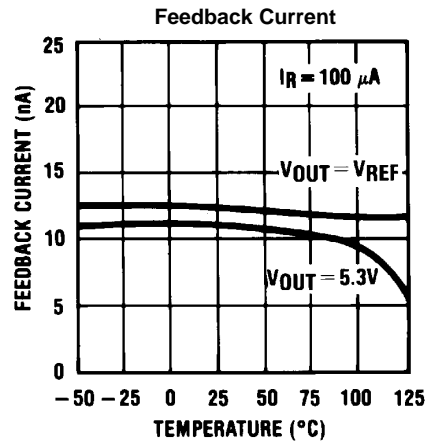

Figure 5.

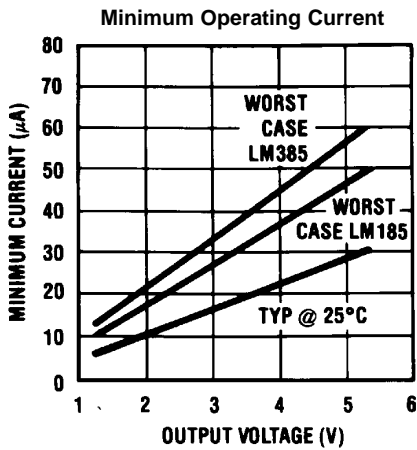

Figure 6.

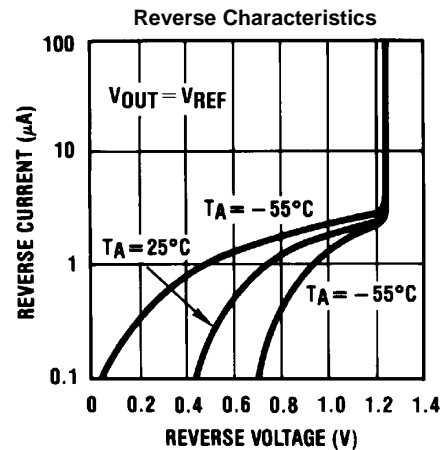

Figure 7.

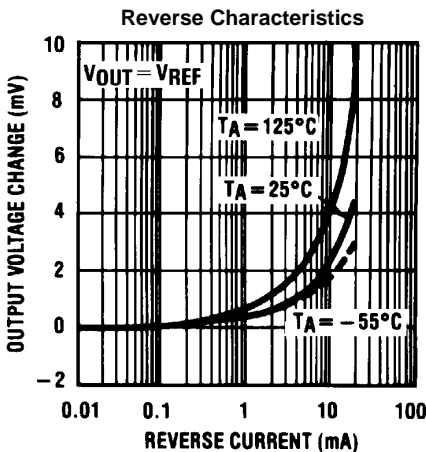

Figure 8.

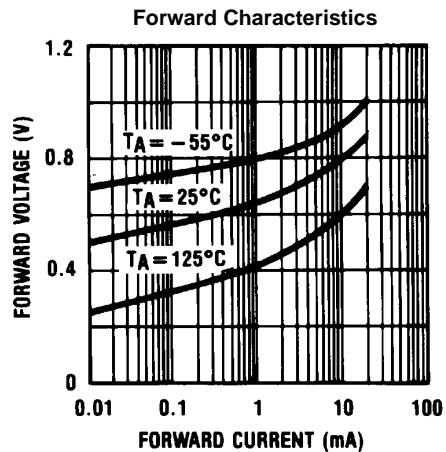

Figure 9.

Typical Performance Characteristics (continued)

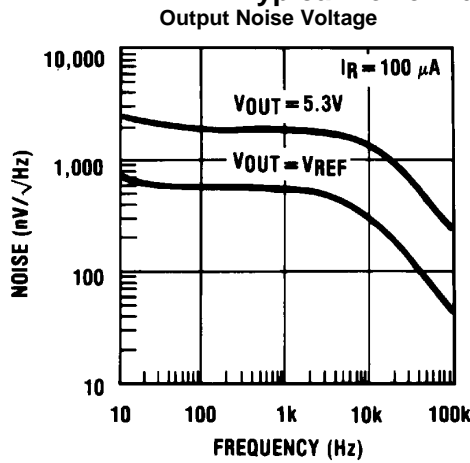

Figure 10.

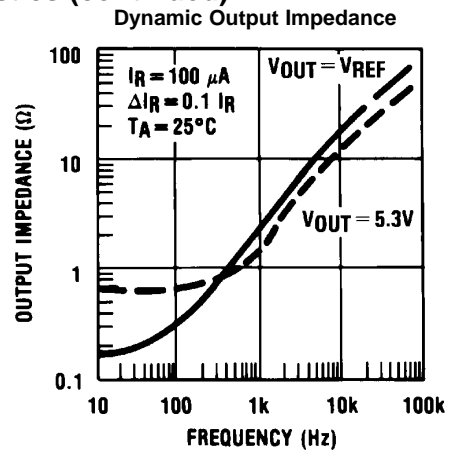

Figure 11.

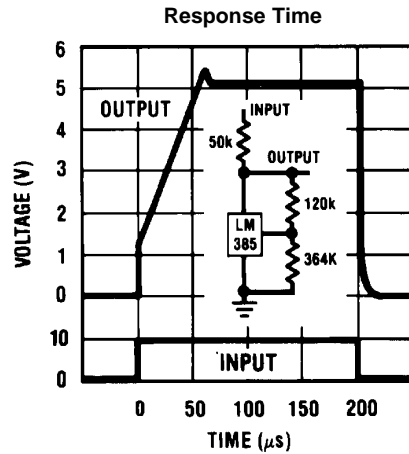

Figure 12.

Temperature Coefficient Typical LM185

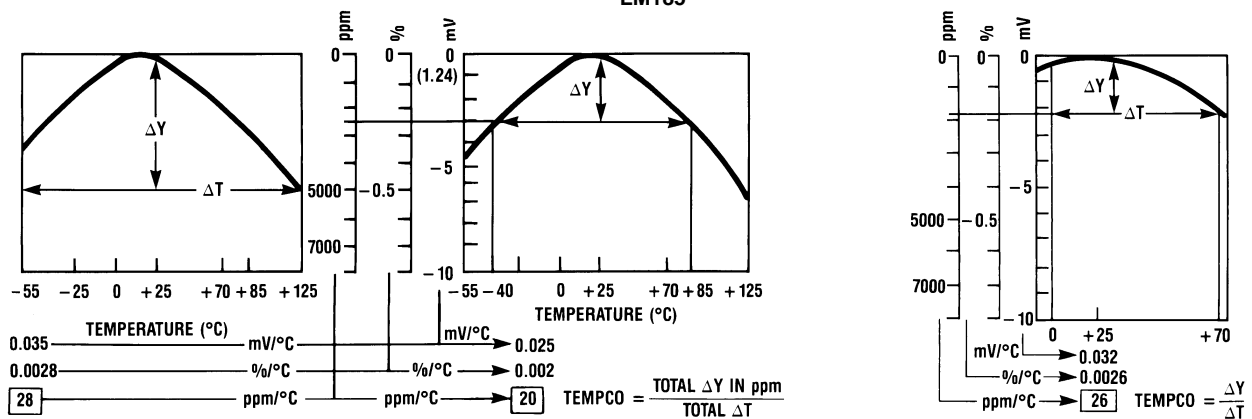

Figure 13.

TYPICAL APPLICATIONS

Precision 10V Reference

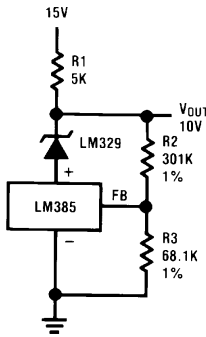

Figure 14.

Low AC Noise Reference

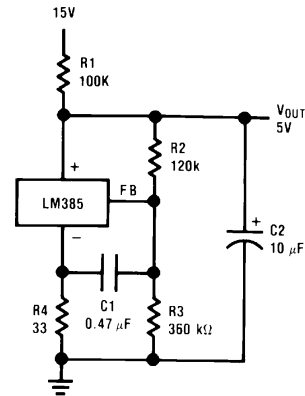

Figure 15.

25V Low Current Shunt Regulator

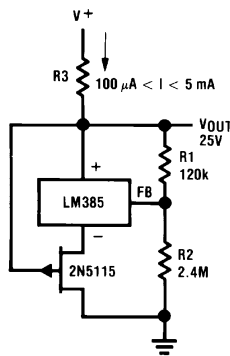

Figure 16.

200 mA Shunt Regulator

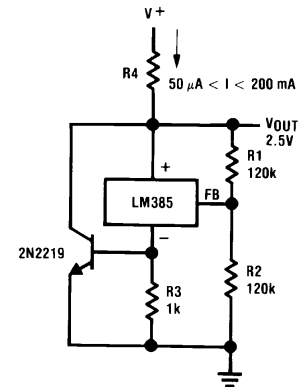

Figure 17.

Series-Shunt 20 mA Regulator

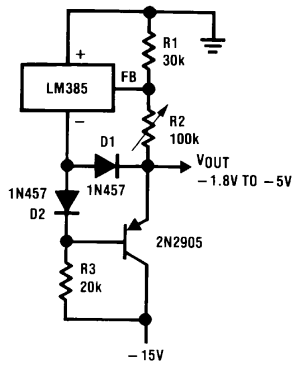

Figure 18.

High Efficiency Low Power Regulator

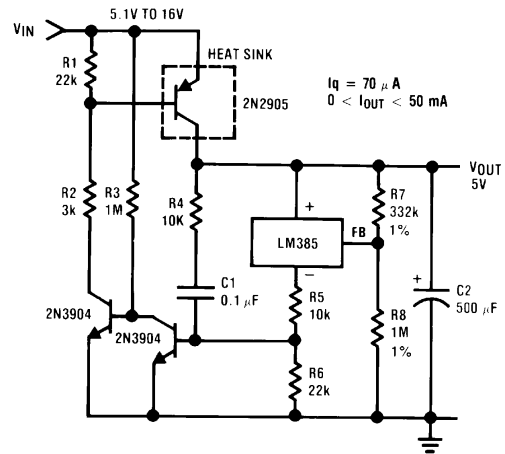

Figure 19.

Voltage Level Detector

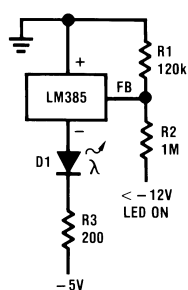

Figure 20.

Voltage Level Detector

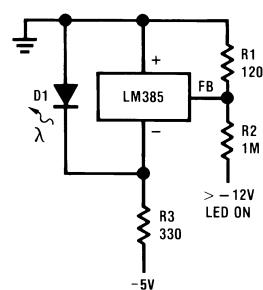

Figure 21.

Fast Positive Clamp
 $2.4V + \Delta V_{D1}$

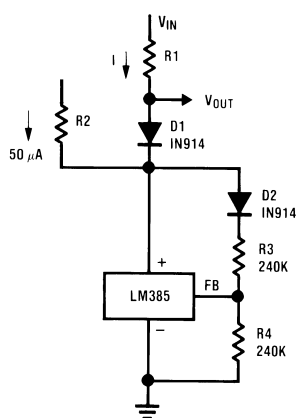

Figure 22.

Bidirectional Clamp
 $\pm 2.4V$

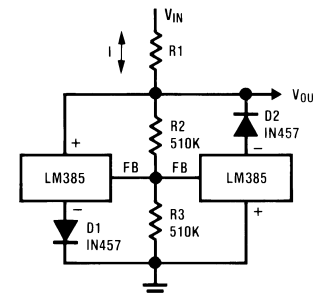

Figure 23.

Bidirectional Adjustable Clamp
 $\pm 1.8V$ to $\pm 2.4V$

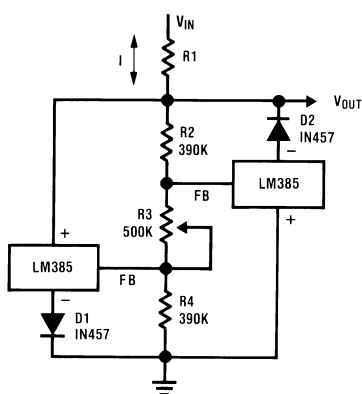

Figure 24.

Bidirectional Adjustable Clamp
 $\pm 2.4V$ to $\pm 6V$

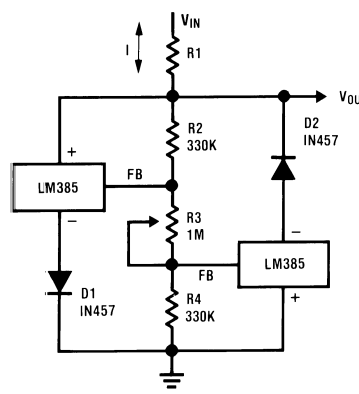

Figure 25.

*D1 can be any LED, $V_F=1.5V$ to $2.2V$ at $3mA$. D1 may act as an indicator. D1 will be on if $I_{THRESHOLD}$ falls below the threshold current, except with $I=0$.

Simple Floating Current Detector

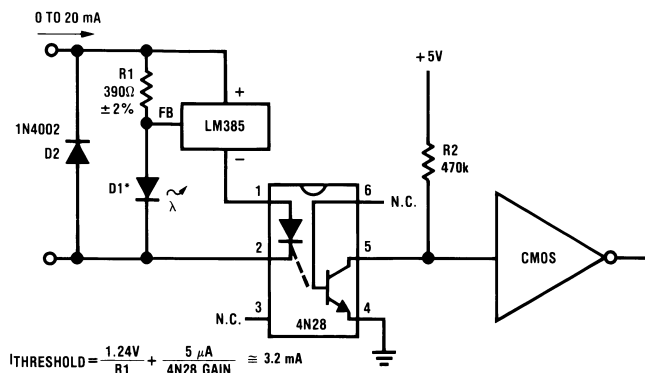

Figure 26.

Precision Floating Current Detector

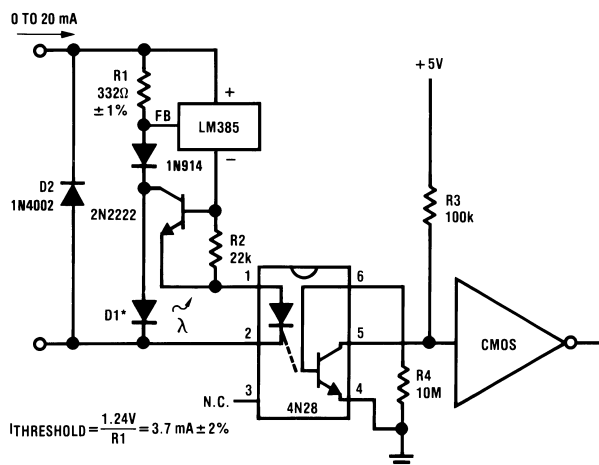

Figure 27.

Current Source

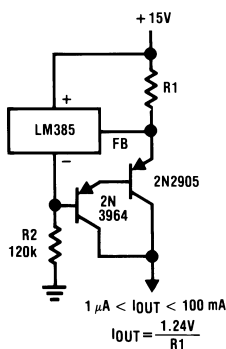

Figure 28.

Centigrade Thermometer, 10mV/°C

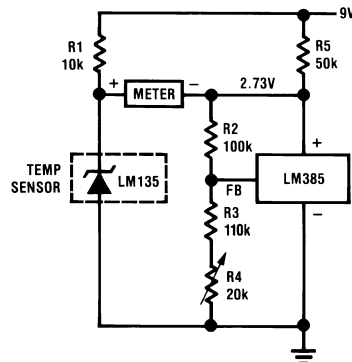

Figure 29.

Freezer Alarm

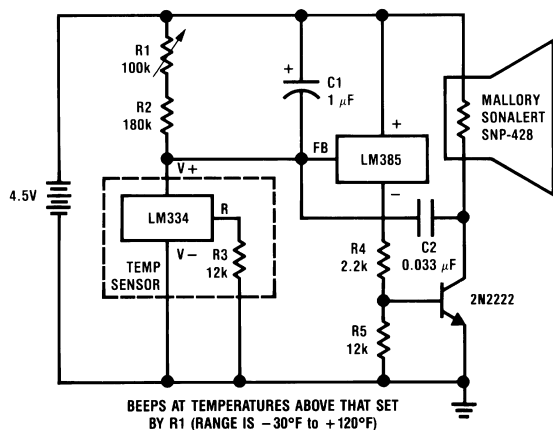

Figure 30.

$$V_{OUT} = 1.24 \left(\frac{R3}{R2} + 1 \right)$$

1.2V Reference

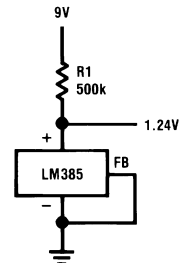

Figure 31.

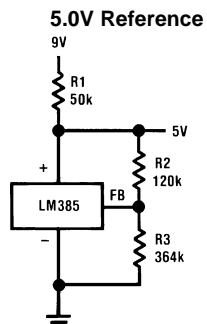



Figure 32.

REVISION HISTORY SECTION

Released	Revision	Section	Originator	Changes
11/08/05	A	New Release, Corporate format	L. Lytle	2 MDS data sheets converted into one Corp. data sheet format. MNLM185B-X Rev 0B0 and MNLM185BY-X Rev 0B0 will be archived.
04/06/06	B	Ordering Information Table, WG Connection Diagram, Absolute Maximum Ratings Section, Physical Dimensions Section	R. Malone	Added NSID, Connection Diagram, Physical Dimension Dwg, Thermal Resistance and Package Weight for NAC package. Revision A will be Archived.
06/12/08	C	LM185B and LM185BY Electrical Section	Larry McGee	Correct IC test, $V_R = V_{REF}$ condition, subgroup 1, 2, 3 moved limits to the maximum column. Revision B will be Archived.
03/27/13	D	All		Changed layout of National Data Sheet to TI format.

PACKAGING INFORMATION

Orderable Device	Status (1)	Package Type	Package Drawing	Pins	Package Qty	Eco Plan (2)	Lead finish/ Ball material (6)	MSL Peak Temp (3)	Op Temp (°C)	Device Marking (4/5)	Samples
5962-9091402QYA	ACTIVE	CFP	NAC	10	54	Non-RoHS & Green	Call TI	Level-1-NA-UNLIM	-55 to 125	LM185BWG /883 Q 5962-90914 02QYA ACO 02QYA >T	
LM185BWG/883	ACTIVE	CFP	NAC	10	54	Non-RoHS & Green	Call TI	Level-1-NA-UNLIM	-55 to 125	LM185BWG /883 Q 5962-90914 02QYA ACO 02QYA >T	

(1) The marketing status values are defined as follows:

ACTIVE: Product device recommended for new designs.

LIFEBUY: TI has announced that the device will be discontinued, and a lifetime-buy period is in effect.

NRND: Not recommended for new designs. Device is in production to support existing customers, but TI does not recommend using this part in a new design.

PREVIEW: Device has been announced but is not in production. Samples may or may not be available.

OBSOLETE: TI has discontinued the production of the device.

(2) **RoHS:** TI defines "RoHS" to mean semiconductor products that are compliant with the current EU RoHS requirements for all 10 RoHS substances, including the requirement that RoHS substance do not exceed 0.1% by weight in homogeneous materials. Where designed to be soldered at high temperatures, "RoHS" products are suitable for use in specified lead-free processes. TI may reference these types of products as "Pb-Free".

RoHS Exempt: TI defines "RoHS Exempt" to mean products that contain lead but are compliant with EU RoHS pursuant to a specific EU RoHS exemption.

Green: TI defines "Green" to mean the content of Chlorine (Cl) and Bromine (Br) based flame retardants meet JS709B low halogen requirements of <=1000ppm threshold. Antimony trioxide based flame retardants must also meet the <=1000ppm threshold requirement.

(3) MSL, Peak Temp. - The Moisture Sensitivity Level rating according to the JEDEC industry standard classifications, and peak solder temperature.

(4) There may be additional marking, which relates to the logo, the lot trace code information, or the environmental category on the device.

(5) Multiple Device Markings will be inside parentheses. Only one Device Marking contained in parentheses and separated by a "~" will appear on a device. If a line is indented then it is a continuation of the previous line and the two combined represent the entire Device Marking for that device.

(6) Lead finish/Ball material - Orderable Devices may have multiple material finish options. Finish options are separated by a vertical ruled line. Lead finish/Ball material values may wrap to two lines if the finish value exceeds the maximum column width.

Important Information and Disclaimer: The information provided on this page represents TI's knowledge and belief as of the date that it is provided. TI bases its knowledge and belief on information provided by third parties, and makes no representation or warranty as to the accuracy of such information. Efforts are underway to better integrate information from third parties. TI has taken and continues to take reasonable steps to provide representative and accurate information but may not have conducted destructive testing or chemical analysis on incoming materials and chemicals. TI and TI suppliers consider certain information to be proprietary, and thus CAS numbers and other limited information may not be available for release.

In no event shall TI's liability arising out of such information exceed the total purchase price of the TI part(s) at issue in this document sold by TI to Customer on an annual basis.

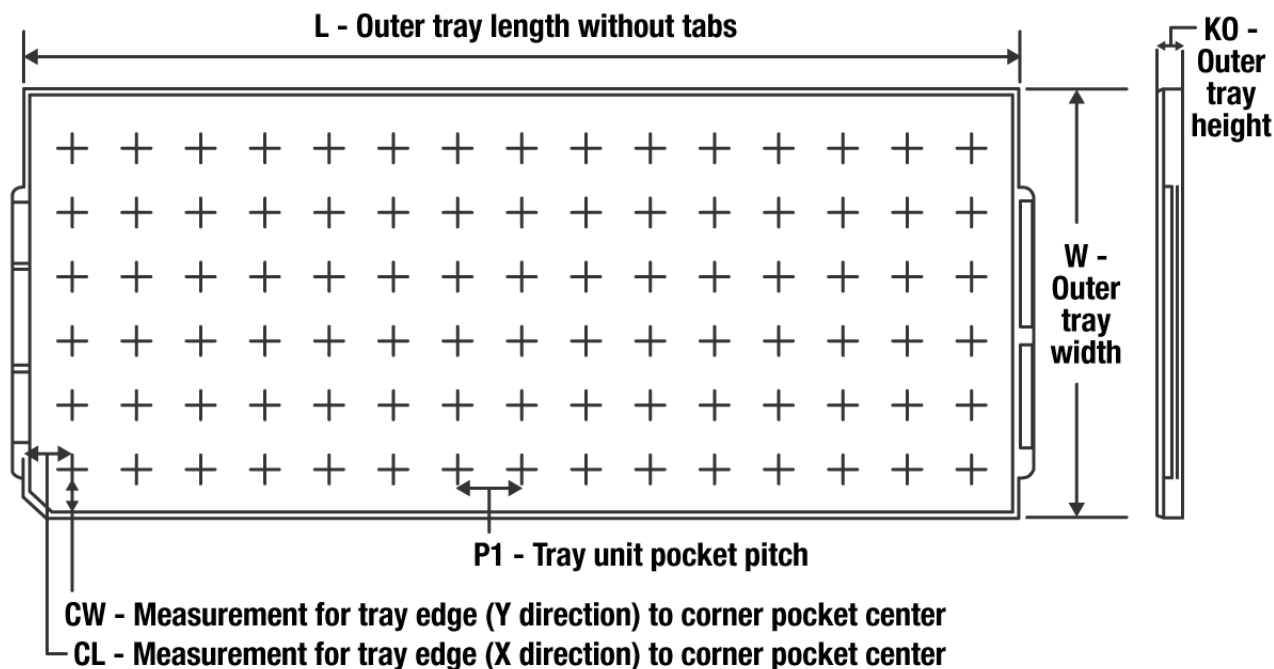
TRAY

Chamfer on Tray corner indicates Pin 1 orientation of packed units.

*All dimensions are nominal

Device	Package Name	Package Type	Pins	SPQ	Unit array matrix	Max temperature (°C)	L (mm)	W (mm)	K0 (µm)	P1 (mm)	CL (mm)	CW (mm)
5962-9091402QYA	NAC	CFP	10	54	6 X 9	100	101.6	101.6	8001	2.78	16.08	16.08
LM185BWG/883	NAC	CFP	10	54	6 X 9	100	101.6	101.6	8001	2.78	16.08	16.08

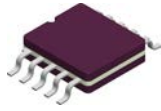

PACKAGE OUTLINE

NAC0010A

CFP - 2.33mm max height

CERAMIC FLATPACK

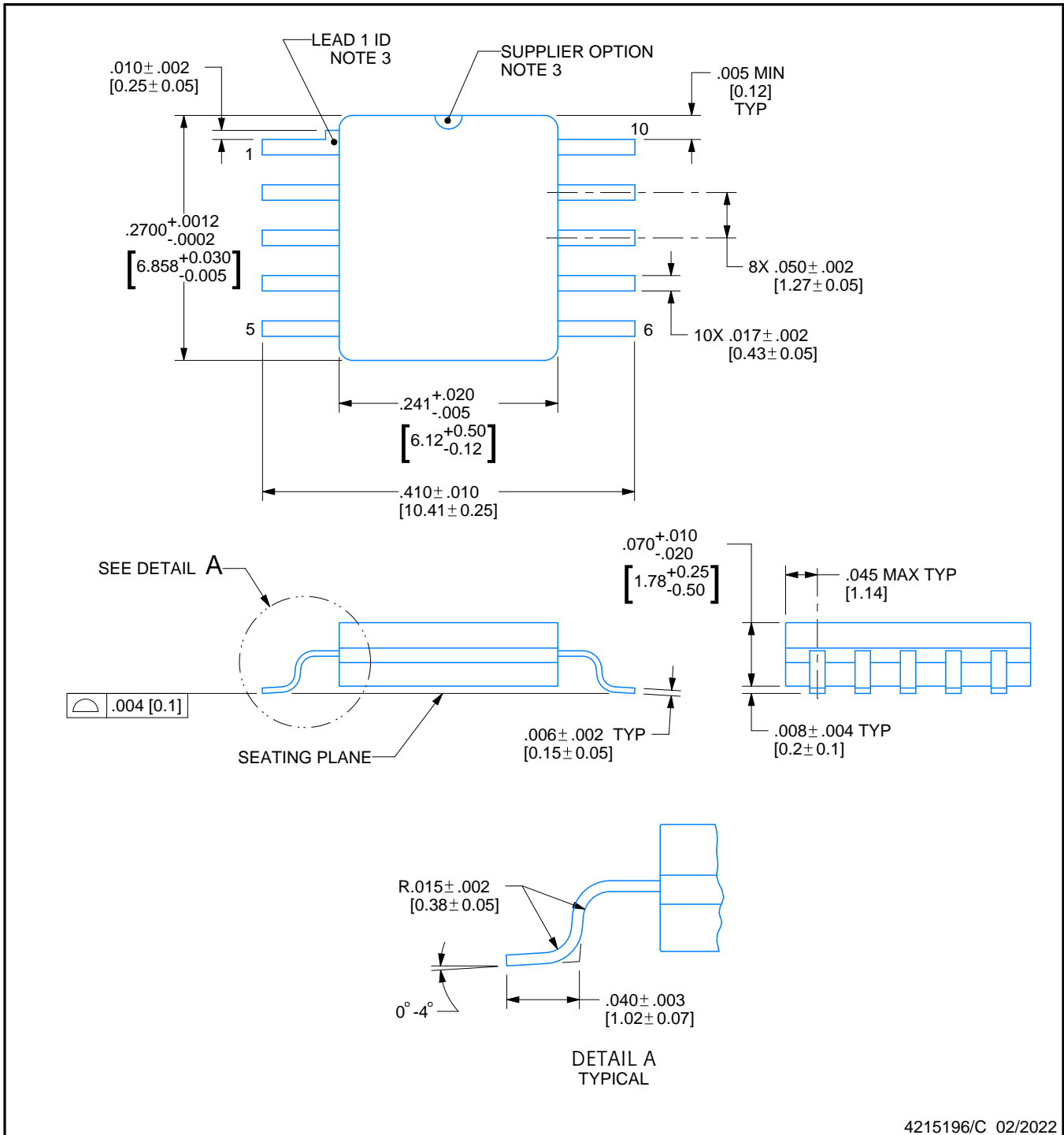

4215196/C 02/2022

NOTES:

1. All controlling linear dimensions are in inches. Dimensions in brackets are in millimeters. Any dimension in brackets or parenthesis are for reference only. Dimensioning and tolerancing per ASME Y14.5M.
2. For solder thickness and composition, see the "Lead Finish Composition/Thickness" link in the packaging section of the Texas Instruments website
3. Lead 1 identification shall be:
 - a) A notch or other mark within this area
 - b) A tab on lead 1, either side
4. No JEDEC registration as of December 2021

EXAMPLE BOARD LAYOUT

NAC0010A

CFP - 2.33mm max height

CERAMIC FLATPACK

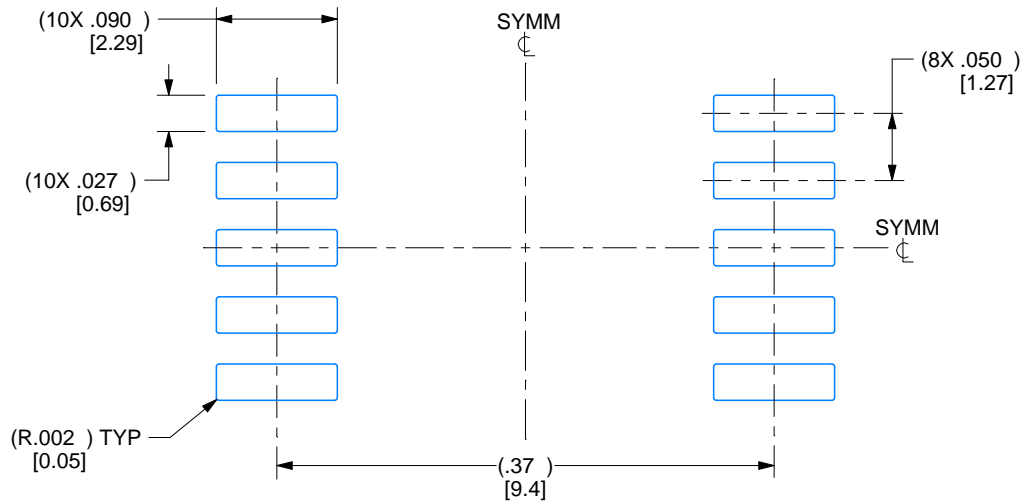

LAND PATTERN EXAMPLE
EXPOSED METAL SHOWN
SCALE: 7X

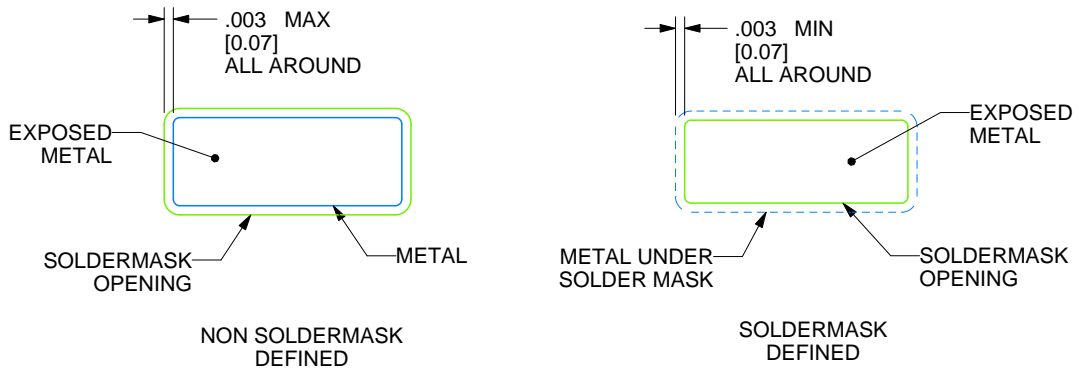

4215196/C 02/2022

IMPORTANT NOTICE AND DISCLAIMER

TI PROVIDES TECHNICAL AND RELIABILITY DATA (INCLUDING DATA SHEETS), DESIGN RESOURCES (INCLUDING REFERENCE DESIGNS), APPLICATION OR OTHER DESIGN ADVICE, WEB TOOLS, SAFETY INFORMATION, AND OTHER RESOURCES "AS IS" AND WITH ALL FAULTS, AND DISCLAIMS ALL WARRANTIES, EXPRESS AND IMPLIED, INCLUDING WITHOUT LIMITATION ANY IMPLIED WARRANTIES OF MERCHANTABILITY, FITNESS FOR A PARTICULAR PURPOSE OR NON-INFRINGEMENT OF THIRD PARTY INTELLECTUAL PROPERTY RIGHTS.

These resources are intended for skilled developers designing with TI products. You are solely responsible for (1) selecting the appropriate TI products for your application, (2) designing, validating and testing your application, and (3) ensuring your application meets applicable standards, and any other safety, security, regulatory or other requirements.

These resources are subject to change without notice. TI grants you permission to use these resources only for development of an application that uses the TI products described in the resource. Other reproduction and display of these resources is prohibited. No license is granted to any other TI intellectual property right or to any third party intellectual property right. TI disclaims responsibility for, and you will fully indemnify TI and its representatives against, any claims, damages, costs, losses, and liabilities arising out of your use of these resources.

TI's products are provided subject to [TI's Terms of Sale](#) or other applicable terms available either on ti.com or provided in conjunction with such TI products. TI's provision of these resources does not expand or otherwise alter TI's applicable warranties or warranty disclaimers for TI products.

TI objects to and rejects any additional or different terms you may have proposed.

Mailing Address: Texas Instruments, Post Office Box 655303, Dallas, Texas 75265
Copyright © 2022, Texas Instruments Incorporated