

具有关断功能的 LM2588 5A 反激式稳压器

1 特性

- 无需外部组件
- 标准电感器和变压器系列
- NPN 输出开关电流为 5A，可切断 65V 电压
- 宽输入电压范围：4V 至 40V
- 可调开关频率：100kHz 至 200kHz
- 外部关断功能
- 关断时消耗电流小于 60 μ A
- 频率同步
- 可改进瞬态响应、线路调节和电流限制的电流模式操作
- 内部软启动功能可降低启动过程中的浪涌电流
- 通过电流限制、欠压锁定和热关断为输出晶体管提供保护
- 在跨线路和负载条件下的最高系统输出电压容差为 $\pm 4\%$
- 使用 LM2588 并借助 [WEBENCH® 电源设计器](#) 创建定制设计方案

2 典型应用

- 反激式稳压器
- 正向转换器
- 多输出稳压器
- 简单升压稳压器

3 说明

LM2588 系列稳压器是专为反激式、升压和正向转换器应用而设计的单片集成电路。该器件提供 4 种不同的输出电压版本：3.3V、5V、12V 和可调节电压。

这些稳压器需要的外部组件很少，因此具有成本效益，并且易于使用。此数据表中包含了典型的升压和反激式稳压器电路。另外还列出了二极管和电容器以及标准电感器和反激式变压器系列的选择指南，这些器件专用于与上述开关稳压器协同工作。

该电源开关是一款 5A NPN 器件，可切断 65V 电压。电源开关由电流和热限制电路以及欠压锁定电路进行保护。此 IC 包含可调频率振荡器，其频率可编程为高达 200kHz。该振荡器还可与其他器件同步，从而可以在同一开关频率下运行多个器件。

其他功能包括在启动期间降低浪涌电流的软启动模式、用于改进抑制输入电压和输出负载瞬态的电流模式控制功能，以及逐周期电流限制。该器件还具有关断引脚，因此可以从外部关闭。在额定输入电压和输出负载条件下，电源系统可确保 $\pm 4\%$ 的输出电压容差。

器件信息(1)

器件型号	封装	封装尺寸 (标称值)
LM2588	TO-220 (7)	10.1mm x 8.89mm
	DDPAK/TO-263 (7)	14.986mm x 10.16mm

(1) 如需了解所有可用封装，请参阅数据表末尾的可订购产品附录。

反激式稳压器

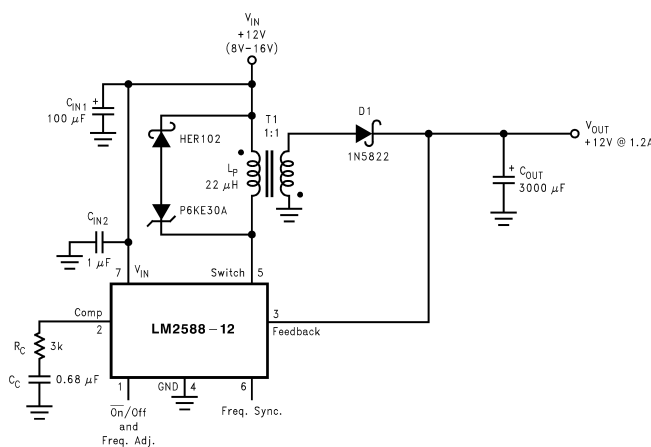

目录

1	特性	1	7.2	Functional Block Diagram	12
2	典型应用	1	7.3	Feature Description	12
3	说明	1	8	Application and Implementation	18
4	修订历史记录	2	8.1	Application Information	18
5	Pin Configurations	3	8.2	Typical Applications	18
6	Specifications	4	8.3	System Examples	28
6.1	Absolute Maximum Ratings	4	9	Layout	29
6.2	ESD Ratings	4	9.1	Layout Guidelines	29
6.3	Recommended Operating Ratings	4	9.2	Layout Example	29
6.4	Electrical Characteristics: 3.3 V	5	9.3	Heat Sink/Thermal Considerations	29
6.5	Electrical Characteristics: 5 V	5	10	器件和文档支持	31
6.6	Electrical Characteristics: 12 V	6	10.1	器件支持	31
6.7	Electrical Characteristics: Adjustable	6	10.2	接收文档更新通知	31
6.8	Electrical Characteristics: All Output Voltage Versions	7	10.3	社区资源	31
6.9	Typical Characteristics	9	10.4	商标	31
7	Detailed Description	12	10.5	静电放电警告	32
7.1	Overview	12	10.6	Glossary	32
			11	机械、封装和可订购信息	32

4 修订历史记录

注：之前版本的页码可能与当前版本有所不同。

Changes from Revision D (April 2013) to Revision E	Page
• 仅有编辑更改；无技术性修订	1
• 已添加 添加了 WEBENCH 链接	1

Changes from Revision C (April 2013) to Revision D	Page
• 将美国国家半导体数据表的布局更改为 TI 格式	1

5 Pin Configurations

**NDZ Package
7-Pin TO-220
Top View, Bent, Staggered Leads**

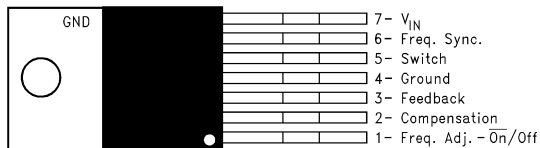

**KTW Package
7-Pin DDPAK/TO-263
Top View**

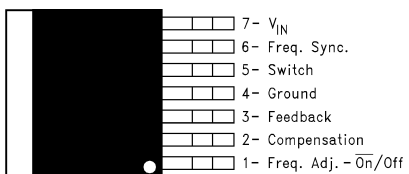

**NDZ Package
7-Pin TO-220
Side View; Bent, Staggered Leads**



**KTW Package
7-Pin DDPAK/TO-263
Side View**



6 Specifications

6.1 Absolute Maximum Ratings

 See ⁽¹⁾⁽²⁾

Input Voltage		$-0.4V \leq V_{IN} \leq 45V$
Switch Voltage		$-0.4V \leq V_{SW} \leq 65V$
Switch Current ⁽³⁾		Internally Limited
Compensation Pin Voltage		$-0.4V \leq V_{COMP} \leq 2.4V$
Feedback Pin Voltage		$-0.4V \leq V_{FB} \leq 2 V_{OUT}$
\overline{ON} /OFF Pin Voltage		$-0.4V \leq V_{SH} \leq 6V$
Sync Pin Voltage		$-0.4V \leq V_{SYNC} \leq 2V$
Power Dissipation ⁽⁴⁾		Internally Limited
Storage Temperature Range		$-65^{\circ}C$ to $+150^{\circ}C$
Lead Temperature	(Soldering, 10 sec.)	$260^{\circ}C$
Maximum Junction Temperature ⁽⁴⁾		$150^{\circ}C$

- (1) Absolute Maximum Ratings indicate limits beyond which damage to the device may occur. These ratings apply when the current is limited to less than 1.2 mA for pins 1, 2, 3, and 6. Operating ratings indicate conditions for which the device is intended to be functional, but device parameter specifications may not be ensured under these conditions. For ensured specifications and test conditions, see the Electrical Characteristics.
- (2) If Military/Aerospace specified devices are required, contact the TI Sales Office/ Distributors for availability and specifications.
- (3) Note that switch current and output current are not identical in a step-up regulator. Output current cannot be internally limited when the LM2588 is used as a step-up regulator. To prevent damage to the switch, the output current must be externally limited to 5A. However, output current is internally limited when the LM2588 is used as a flyback regulator (see the section for more information).
- (4) The junction temperature of the device (T_J) is a function of the ambient temperature (T_A), the junction-to-ambient thermal resistance (θ_{JA}), and the power dissipation of the device (P_D). A thermal shutdown will occur if the temperature exceeds the maximum junction temperature of the device: $P_D \times \theta_{JA} + T_{A(MAX)} \geq T_{J(MAX)}$. For a safe thermal design, check that the maximum power dissipated by the device is less than: $P_D \leq [T_{J(MAX)} - T_{A(MAX)}] / \theta_{JA}$. When calculating the maximum allowable power dissipation, derate the maximum junction temperature—this ensures a margin of safety in the thermal design.

6.2 ESD Ratings

			VALUE	UNIT
$V_{(ESD)}$	Electrostatic discharge (minimum)	Human-body model (HBM), per ANSI/ESDA/JEDEC JS-001 ⁽¹⁾ (C = 100 pF, R = 1.5 k Ω)	2000	V

- (1) JEDEC document JEP155 states that 500-V HBM allows safe manufacturing with a standard ESD control process.

6.3 Recommended Operating Ratings

Supply Voltage	$4V \leq V_{IN} \leq 40V$
Output Switch Voltage	$0V \leq V_{SW} \leq 60V$
Output Switch Current	$I_{SW} \leq 5.0A$
Junction Temperature Range	$-40^{\circ}C \leq T_J \leq +125^{\circ}C$

6.4 Electrical Characteristics: 3.3 V

Specifications with standard type face are for $T_J = 25^\circ\text{C}$, and those in **boldtype face** apply over full **Operating Temperature Range**. Unless otherwise specified, $V_{IN} = 5\text{V}$.

PARAMETER	TEST CONDITIONS	TYP	MIN	MAX	UNIT	
SYSTEM PARAMETERS Test Circuit of Figure 54 ⁽¹⁾						
V_{OUT}	Output Voltage	$V_{IN} = 4\text{V to }12\text{V}$ $I_{LOAD} = 400\text{ mA to }1.75\text{A}$	3.3	3.17/ 3.14	3.43/ 3.46	V
$\frac{\Delta V_{OUT}}{\Delta V_{IN}}$	Line Regulation	$V_{IN} = 4\text{V to }12\text{V}$ $I_{LOAD} = 400\text{ mA}$	20		50/ 100	mV
$\frac{\Delta V_{OUT}}{\Delta I_{LOAD}}$	Load Regulation	$V_{IN} = 12\text{V}$ $I_{LOAD} = 400\text{ mA to }1.75\text{A}$	20		50/ 100	mV
η	Efficiency	$V_{IN} = 12\text{V}$, $I_{LOAD} = 1\text{A}$	75			%
UNIQUE DEVICE PARAMETERS ⁽²⁾						
V_{REF}	Output Reference Voltage	Measured at Feedback Pin $V_{COMP} = 1.0\text{V}$	3.3	3.242/ 3.234	3.358/ 3.366	V
ΔV_{REF}	Reference Voltage Line Regulation	$V_{IN} = 4\text{V to }40\text{V}$	2.0			mV
G_M	Error Amp Transconductance	$I_{COMP} = -30\ \mu\text{A to }+30\ \mu\text{A}$ $V_{COMP} = 1.0\text{V}$	1.193	0.678	2.259	mmho
A_{VOL}	Error Amp Voltage Gain	$V_{COMP} = 0.5\text{V to }1.6\text{V}$ $R_{COMP} = 1.0\ \text{M}\Omega$ ⁽³⁾	260	151/ 75		V/V

(1) External components such as the diode, inductor, input and output capacitors can affect switching regulator performance. When the LM2588 is used as shown in [Figure 54](#) and [Figure 55](#), system performance will be as specified by the system parameters.

(2) All room temperature limits are 100% production tested, and all limits at temperature extremes are specified via correlation using standard Statistical Quality Control (SQC) methods.

(3) A 1.0 M Ω resistor is connected to the compensation pin (which is the error amplifier output) to ensure accuracy in measuring A_{VOL} .

6.5 Electrical Characteristics: 5 V

Specifications with standard type face are for $T_J = 25^\circ\text{C}$, and those in **bold type face** apply over full **Operating Temperature Range**. Unless otherwise specified, $V_{IN} = 5\text{V}$.

PARAMETER	TEST CONDITIONS	TYP	MIN	MAX	UNIT	
SYSTEM PARAMETERS Test Circuit of Figure 54 ⁽¹⁾						
V_{OUT}	Output Voltage	$V_{IN} = 4\text{V to }12\text{V}$ $I_{LOAD} = 500\text{ mA to }1.45\text{A}$	5.0	4.80/ 4.75	5.20/ 5.25	V
$\frac{\Delta V_{OUT}}{\Delta V_{IN}}$	Line Regulation	$V_{IN} = 4\text{V to }12\text{V}$ $I_{LOAD} = 500\text{ mA}$	20		50/ 100	mV
$\frac{\Delta V_{OUT}}{\Delta I_{LOAD}}$	Load Regulation	$V_{IN} = 12\text{V}$ $I_{LOAD} = 500\text{ mA to }1.45\text{A}$	20		50/ 100	mV
η	Efficiency	$V_{IN} = 12\text{V}$, $I_{LOAD} = 750\text{ mA}$	80			%
UNIQUE DEVICE PARAMETERS ⁽²⁾						
V_{REF}	Output Reference Voltage	Measured at Feedback Pin $V_{COMP} = 1.0\text{V}$	5.0	4.913/ 4.900	5.088/ 5.100	V
ΔV_{REF}	Reference Voltage Line Regulation	$V_{IN} = 4\text{V to }40\text{V}$	3.3			mV
G_M	Error Amp Transconductance	$I_{COMP} = -30\ \mu\text{A to }+30\ \mu\text{A}$ $V_{COMP} = 1.0\text{V}$	0.750	0.447	1.491	mmho
A_{VOL}	Error Amp Voltage Gain	$V_{COMP} = 0.5\text{V to }1.6\text{V}$ $R_{COMP} = 1.0\ \text{M}\Omega$ ⁽³⁾	165	99/ 49		V/V

(1) External components such as the diode, inductor, input and output capacitors can affect switching regulator performance. When the LM2588 is used as shown in [Figure 54](#) and [Figure 55](#), system performance will be as specified by the system parameters.

(2) All room temperature limits are 100% production tested, and all limits at temperature extremes are specified via correlation using standard Statistical Quality Control (SQC) methods.

(3) A 1.0 M Ω resistor is connected to the compensation pin (which is the error amplifier output) to ensure accuracy in measuring A_{VOL} .

6.6 Electrical Characteristics: 12 V

Specifications with standard type face are for $T_J = 25^\circ\text{C}$, and those in **bold type face** apply over full **Operating Temperature Range**. Unless otherwise specified, $V_{IN} = 5\text{V}$.

PARAMETER		TEST CONDITIONS	TYP	MIN	MAX	UNIT
SYSTEM PARAMETERS Test Circuit of Figure 55 ⁽¹⁾						
V_{OUT}	Output Voltage	$V_{IN} = 4\text{V to }10\text{V}$ $I_{LOAD} = 300\text{ mA to }1.2\text{A}$	12.0	11.52/ 11.40	12.48/ 12.60	V
$\frac{\Delta V_{OUT}}{\Delta V_{IN}}$	Line Regulation	$V_{IN} = 4\text{V to }10\text{V}$ $I_{LOAD} = 300\text{ mA}$	20		100/ 200	mV
$\frac{\Delta V_{OUT}}{\Delta I_{LOAD}}$	Load Regulation	$V_{IN} = 10\text{V}$ $I_{LOAD} = 300\text{ mA to }1.2\text{A}$	20		100/ 200	mV
η	Efficiency	$V_{IN} = 10\text{V}$, $I_{LOAD} = 1\text{A}$	90			%
UNIQUE DEVICE PARAMETERS ⁽²⁾						
V_{REF}	Output Reference Voltage	Measured at Feedback Pin $V_{COMP} = 1.0\text{V}$	12.0	11.79/ 11.76	12.21/ 12.24	V
ΔV_{REF}	Reference Voltage Line Regulation	$V_{IN} = 4\text{V to }40\text{V}$	7.8			mV
G_M	Error Amp Transconductance	$I_{COMP} = -30\ \mu\text{A to }+30\ \mu\text{A}$ $V_{COMP} = 1.0\text{V}$	0.328	0.186	0.621	mmho
A_{VOL}	Error Amp Voltage Gain	$V_{COMP} = 0.5\text{V to }1.6\text{V}$ $R_{COMP} = 1.0\ \text{M}\Omega$ ⁽³⁾	70	41/ 21		V/V

(1) External components such as the diode, inductor, input and output capacitors can affect switching regulator performance. When the LM2588 is used as shown in [Figure 54](#) and [Figure 55](#), system performance will be as specified by the system parameters.

(2) All room temperature limits are 100% production tested, and all limits at temperature extremes are specified via correlation using standard Statistical Quality Control (SQC) methods.

(3) A 1.0 M Ω resistor is connected to the compensation pin (which is the error amplifier output) to ensure accuracy in measuring A_{VOL} .

6.7 Electrical Characteristics: Adjustable

Specifications with standard type face are for $T_J = 25^\circ\text{C}$, and those in **bold type face** apply over full **Operating Temperature Range**. Unless otherwise specified, $V_{IN} = 5\text{V}$.

PARAMETER		TEST CONDITIONS	TYP	MIN	MAX	UNIT
SYSTEM PARAMETERS Test Circuit of Figure 55 ⁽¹⁾						
V_{OUT}	Output Voltage	$V_{IN} = 4\text{V to }10\text{V}$ $I_{LOAD} = 300\text{ mA to }1.2\text{A}$	12.0	11.52/ 11.40	12.48/ 12.60	V
$\frac{\Delta V_{OUT}}{\Delta V_{IN}}$	Line Regulation	$V_{IN} = 4\text{V to }10\text{V}$ $I_{LOAD} = 300\text{ mA}$	20		100/ 200	mV
$\frac{\Delta V_{OUT}}{\Delta I_{LOAD}}$	Load Regulation	$V_{IN} = 10\text{V}$ $I_{LOAD} = 300\text{ mA to }1.2\text{A}$	20		100/ 200	mV
η	Efficiency	$V_{IN} = 10\text{V}$, $I_{LOAD} = 1\text{A}$	90			%
UNIQUE DEVICE PARAMETERS ⁽²⁾						
V_{REF}	Output Reference Voltage	Measured at Feedback Pin $V_{COMP} = 1.0\text{V}$	1.230	1.208/ 1.205	1.252/ 1.255	V
ΔV_{REF}	Reference Voltage Line Regulation	$V_{IN} = 4\text{V to }40\text{V}$	1.5			mV
G_M	Error Amp Transconductance	$I_{COMP} = -30\ \mu\text{A to }+30\ \mu\text{A}$ $V_{COMP} = 1.0\text{V}$	3.200	1.800	6.000	mmho
A_{VOL}	Error Amp Voltage Gain	$V_{COMP} = 0.5\text{V to }1.6\text{V}$ $R_{COMP} = 1.0\ \text{M}\Omega$ ⁽³⁾	670	400/ 200		V/V
I_B	Error Amp Input Bias Current	$V_{COMP} = 1.0\text{V}$	125		425/ 600	nA

(1) External components such as the diode, inductor, input and output capacitors can affect switching regulator performance. When the LM2588 is used as shown in [Figure 54](#) and [Figure 55](#), system performance will be as specified by the system parameters.

(2) All room temperature limits are 100% production tested, and all limits at temperature extremes are specified via correlation using standard Statistical Quality Control (SQC) methods.

(3) A 1.0 M Ω resistor is connected to the compensation pin (which is the error amplifier output) to ensure accuracy in measuring A_{VOL} .

6.8 Electrical Characteristics: All Output Voltage Versions ⁽¹⁾

Specifications with standard type face are for $T_J = 25^\circ\text{C}$, and those in **bold type face** apply over full **Operating Temperature Range**. Unless otherwise specified, $V_{IN} = 5\text{V}$.

PARAMETER		TEST CONDITIONS	TYP	MIN	MAX	UNIT
I_S	Input Supply Current	Switch Off ⁽²⁾	11		15.5/ 16.5	mA
		$I_{\text{SWITCH}} = 3.0\text{A}$	85		140/ 165	mA
$I_{S/D}$	Shutdown Input Supply Current	$V_{SH} = 3\text{V}$	16		100/ 300	μA
V_{UV}	Input Supply Undervoltage Lockout	$R_{\text{LOAD}} = 100\Omega$	3.30	3.05	3.75	V
f_O	Oscillator Frequency	Measured at Switch Pin $R_{\text{LOAD}} = 100\Omega$, $V_{\text{COMP}} = 1.0\text{V}$ Freq. Adj. Pin Open (Pin 1)	100	85/75	115/125	kHz
		$R_{\text{SET}} = 22\text{ k}\Omega$	200			kHz
f_{SC}	Short-Circuit Frequency	Measured at Switch Pin $R_{\text{LOAD}} = 100\Omega$ $V_{\text{FEEDBACK}} = 1.15\text{V}$	25			kHz
V_{EAO}	Error Amplifier Output Swing	Upper Limit ⁽³⁾	2.8	2.6/ 2.4		V
		Lower Limit ⁽²⁾	0.25		0.40/ 0.55	V
I_{EAO}	Error Amp Output Current (Source or Sink)	See ⁽⁴⁾	165	110/ 70	260/ 320	μA
I_{SS}	Soft Start Current	$V_{\text{FEEDBACK}} = 0.92\text{V}$ $V_{\text{COMP}} = 1.0\text{V}$	11.0	8.0/ 7.0	17.0/ 19.0	μA
D_{MAX}	Maximum Duty Cycle	$R_{\text{LOAD}} = 100\Omega$ ⁽³⁾	98	93/90		%
I_L	Switch Leakage Current	Switch Off $V_{\text{SWITCH}} = 60\text{V}$	15		300/ 600	μA
V_{SUS}	Switch Sustaining Voltage	$dV/dT = 1.5\text{V/ns}$		65		V
V_{SAT}	Switch Saturation Voltage	$I_{\text{SWITCH}} = 5.0\text{A}$	0.7		1.1/ 1.4	V
I_{CL}	NPN Switch Current Limit		6.5	5.0	9.5	A
V_{STH}	Synchronization Threshold Voltage	$F_{\text{SYNC}} = 200\text{ kHz}$ $V_{\text{COMP}} = 1\text{V}$, $V_{\text{IN}} = 5\text{V}$	0.75	0.625/ 0.40	0.875/ 1.00	V
I_{SYNC}	Synchronization Pin Current	$V_{\text{IN}} = 5\text{V}$ $V_{\text{COMP}} = 1\text{V}$, $V_{\text{SYNC}} = V_{\text{STH}}$	100		200	μA
V_{SHTH}	$\overline{\text{ON}}$ /OFF Pin (Pin 1) Threshold Voltage	$V_{\text{COMP}} = 1\text{V}$ ⁽⁵⁾	1.6	1.0/ 0.8	2.2/ 2.4	V
I_{SH}	$\overline{\text{ON}}$ /OFF Pin (Pin 1) Current	$V_{\text{COMP}} = 1\text{V}$ $V_{\text{SH}} = V_{\text{SHTH}}$	40	15/ 10	65/ 75	μA

- (1) All room temperature limits are 100% production tested, and all limits at temperature extremes are specified via correlation using standard Statistical Quality Control (SQC) methods.
- (2) To measure this parameter, the feedback voltage is set to a high value, depending on the output version of the device, to force the error amplifier output low and the switch off.
- (3) To measure this parameter, the feedback voltage is set to a low value, depending on the output version of the device, to force the error amplifier output high and the switch on.
- (4) To measure the worst-case error amplifier output current, the LM2588 is tested with the feedback voltage set to its low value (specified in Note 3 under the [Electrical Characteristics: All Output Voltage Versions](#) ⁽¹⁾ table) and at its high value (specified in Note 2 under the [Electrical Characteristics: All Output Voltage Versions](#) ⁽¹⁾ table).
- (5) When testing the minimum value, do not sink current from this pin—isolate it with a diode. If current is drawn from this pin, the frequency adjust circuit will begin operation (see [Figure 20](#)).

Electrical Characteristics: All Output Voltage Versions ⁽¹⁾ (continued)

Specifications with standard type face are for $T_J = 25^\circ\text{C}$, and those in **bold type face** apply over full **Operating Temperature Range**. Unless otherwise specified, $V_{IN} = 5\text{V}$.

PARAMETER		TEST CONDITIONS	TYP	MIN	MAX	UNIT
θ_{JA}	Thermal Resistance	NDZ Package, Junction to Ambient ⁽⁶⁾	65			°C/W
θ_{JA}		NDZ Package, Junction to Ambient ⁽⁷⁾	45			
θ_{JC}		NDZ Package, Junction to Case	2			
θ_{JA}		KTW Package, Junction to Ambient ⁽⁸⁾	56			
θ_{JA}		KTW Package, Junction to Ambient ⁽⁹⁾	35			
θ_{JA} θ_{JC}		KTW Package, Junction to Ambient ⁽¹⁰⁾	26 2			
		KTW Package, Junction to Case				

- (6) Junction to ambient thermal resistance (no external heat sink) for the 7 lead TO-220 package mounted vertically, with ½ inch leads in a socket, or on a PC board with minimum copper area.
- (7) Junction to ambient thermal resistance (no external heat sink) for the 7 lead TO-220 package mounted vertically, with ½ inch leads soldered to a PC board containing approximately 4 square inches of (1 oz.) copper area surrounding the leads.
- (8) Junction to ambient thermal resistance for the 7 lead TO-263 mounted horizontally against a PC board area of 0.136 square inches (the same size as the TO-263 package) of 1 oz. (0.0014 in. thick) copper.
- (9) Junction to ambient thermal resistance for the 7 lead TO-263 mounted horizontally against a PC board area of 0.4896 square inches (3.6 times the area of the TO-263 package) of 1 oz. (0.0014 in. thick) copper.
- (10) Junction to ambient thermal resistance for the 7 lead TO-263 mounted horizontally against a PC board copper area of 1.0064 square inches (7.4 times the area of the TO-263 package) of 1 oz. (0.0014 in. thick) copper. Additional copper area will reduce thermal resistance further. See the thermal model in Switchers Made Simple[®] software.

6.9 Typical Characteristics

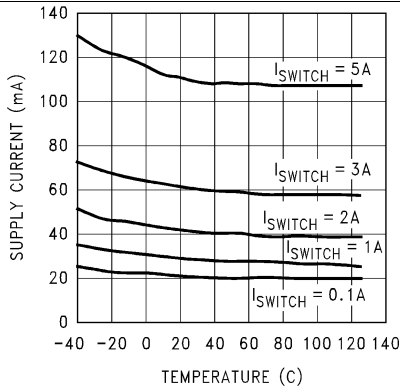

Figure 1. Supply Current vs Temperature

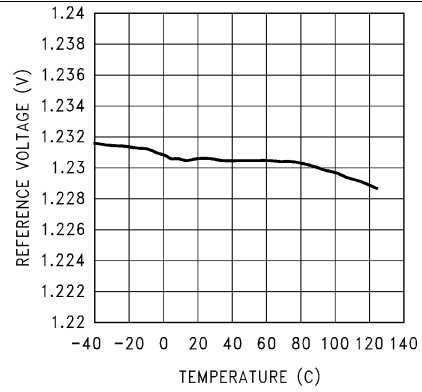

Figure 2. Reference Voltage vs Temperature

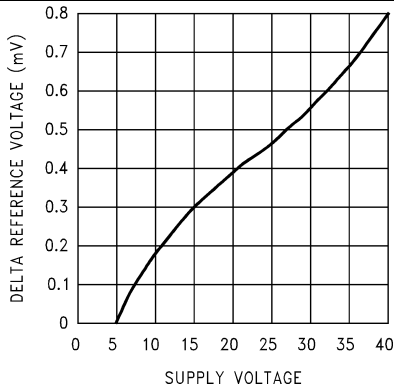

Figure 3. ΔReference Voltage vs Supply Voltage

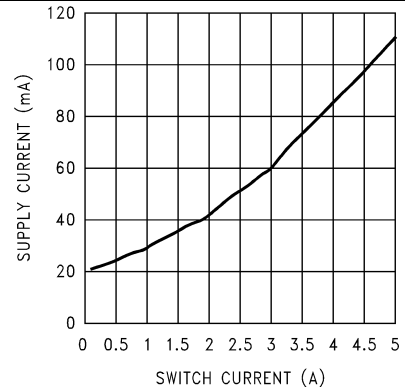

Figure 4. Supply Current vs Switch Current

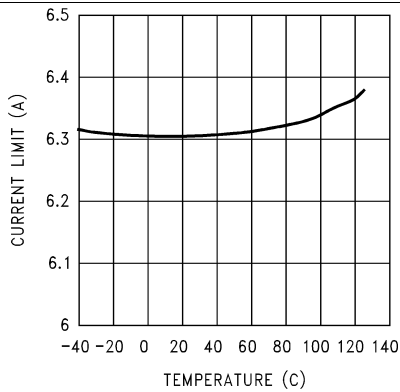

Figure 5. Current Limit vs Temperature

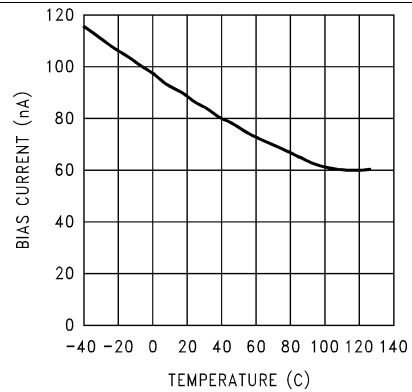

Figure 6. Feedback Pin Bias Current vs Temperature

Typical Characteristics (continued)

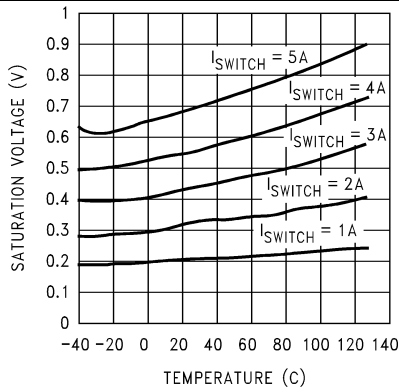

Figure 7. Switch Saturation Voltage vs Temperature

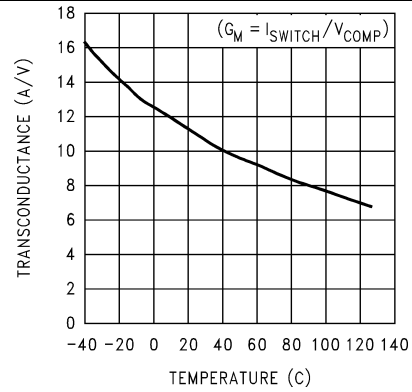

Figure 8. Switch Transconductance vs Temperature

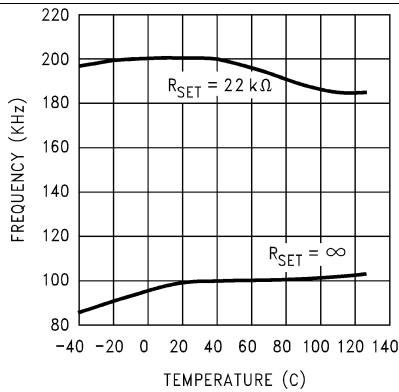

Figure 9. Oscillator Frequency vs Temperature

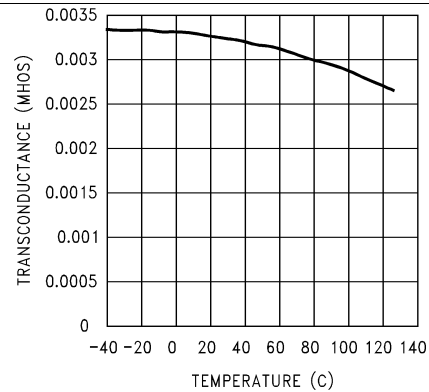

Figure 10. Error Amp Transconductance vs Temperature

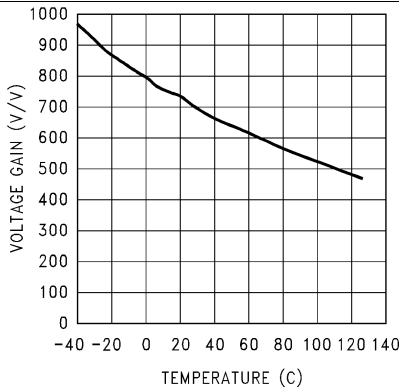

Figure 11. Error Amp Voltage Gain vs Temperature

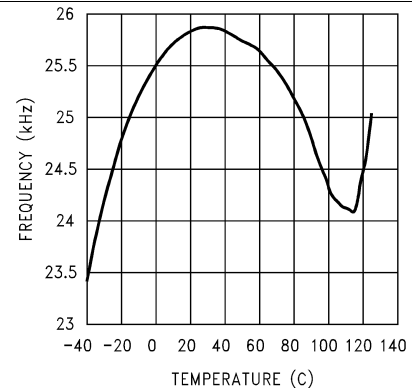

Figure 12. Short Circuit Frequency vs Temperature

Typical Characteristics (continued)

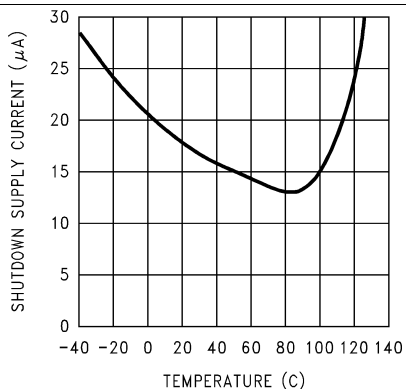

Figure 13. Shutdown Supply Current vs Temperature

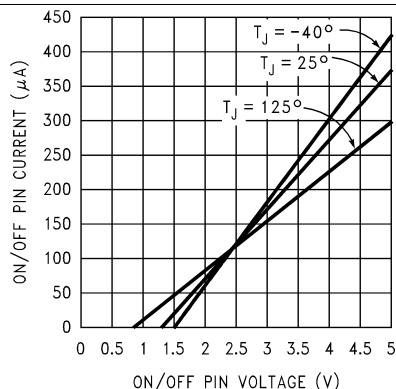

Figure 14. $\overline{\text{ON}}$ /Off Pin Current vs Voltage

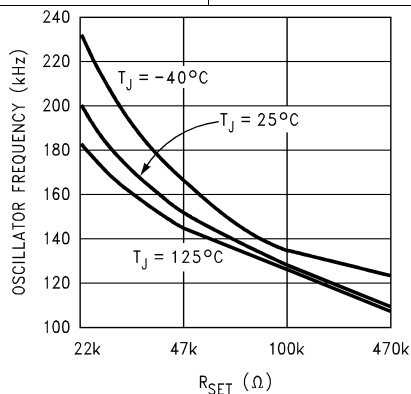

Figure 15. Oscillator Frequency vs Resistance

7 Detailed Description

7.1 Overview

The LM2588 series of regulators are monolithic integrated circuits specifically designed for flyback, step-up (boost), and forward converter applications. The device is available in 4 different output voltage versions: 3.3 V, 5 V, 12 V, and adjustable. Requiring a minimum number of external components, these regulators are cost effective, and simple to use. Included in the datasheet are typical circuits of boost and flyback regulators. Also listed are selector guides for diodes and capacitors and a family of standard inductors and flyback transformers designed to work with these switching regulators.

7.2 Functional Block Diagram

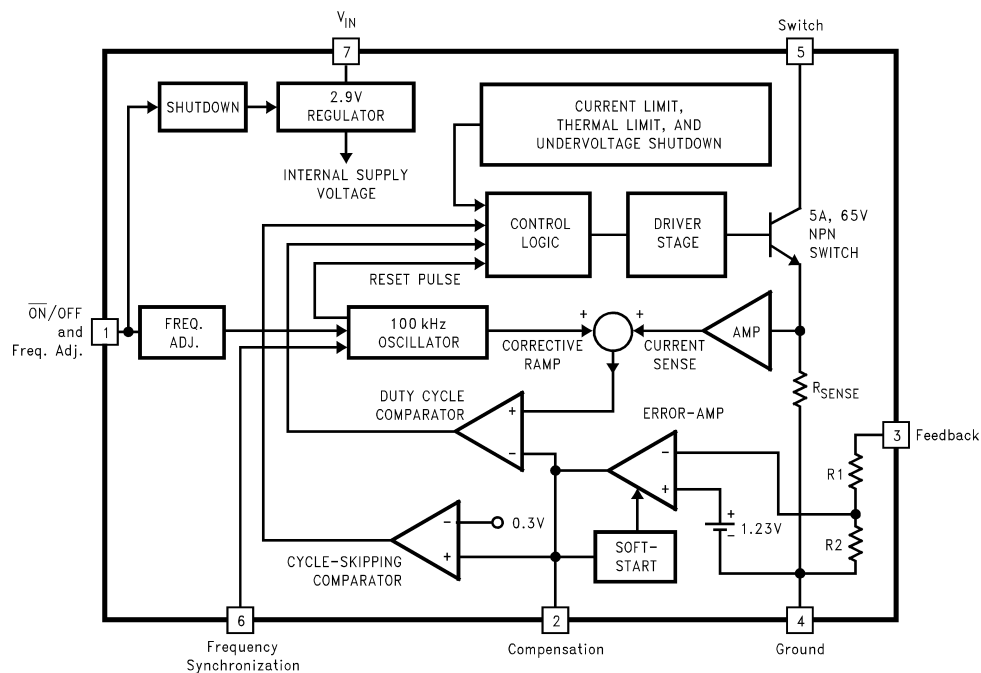

For Fixed Versions 3.3V, R1 = 3.4k, R2 = 2k5.0V, R1 = 6.15k, R2 = 2k12V, R1 = 8.73k, R2 = 1k For Adj. Version R1 = Short (0 Ω), R2 = Open

7.3 Feature Description

7.3.1 Flyback Regulator Operation

The operation of a flyback regulator is as follows (refer to [Figure 16](#)): when the switch is on, current flows through the primary winding of the transformer, T1, storing energy in the magnetic field of the transformer. Note that the primary and secondary windings are out of phase, so no current flows through the secondary when current flows through the primary. When the switch turns off, the magnetic field collapses, reversing the voltage polarity of the primary and secondary windings. Now rectifier D1 is forward biased and current flows through it, releasing the energy stored in the transformer. This produces voltage at the output.

The output voltage is controlled by modulating the peak switch current. This is done by feeding back a portion of the output voltage to the error amp, which amplifies the difference between the feedback voltage and a 1.23-V reference. The error amp output voltage is compared to a ramp voltage proportional to the switch current (in other words, inductor current during the switch on-time). The comparator terminates the switch on time when the two voltages are equal, thereby controlling the peak switch current to maintain a constant output voltage.

Feature Description (continued)

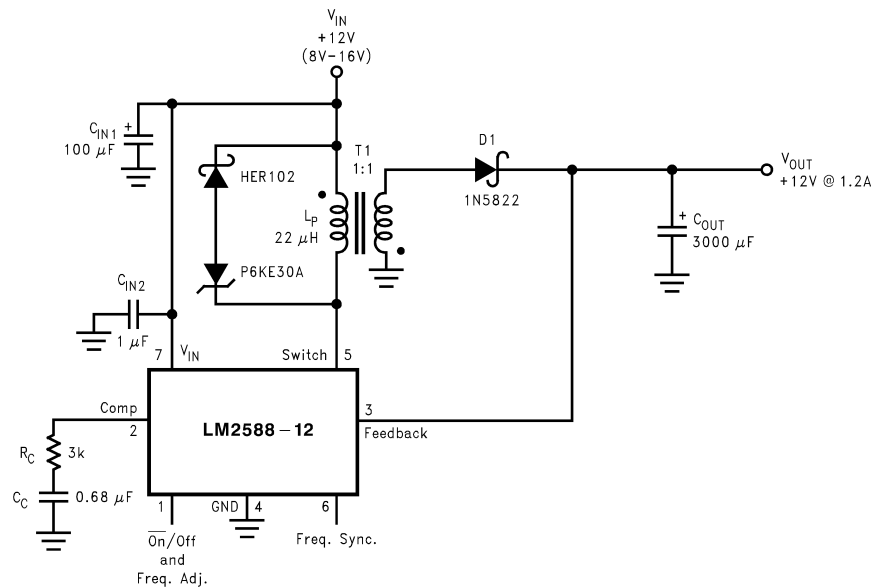

As shown in Figure 16, the LM2588 can be used as a flyback regulator by using a minimum number of external components. The switching waveforms of this regulator are shown in Figure 18. Typical characteristics observed during the operation of this circuit are shown in Figure 19.

Figure 16. 12-V Flyback Regulator Design Example

7.3.2 Step-Up (Boost) Regulator Operation

Figure 17 shows the LM2588 used as a step-up (boost) regulator. This is a switching regulator that produces an output voltage greater than the input supply voltage.

A brief explanation of how the LM2588 boost regulator works is as follows (refer to Figure 17). When the NPN switch turns on, the inductor current ramps up at the rate of V_{IN}/L , storing energy in the inductor. When the switch turns off, the lower end of the inductor flies above V_{IN} , discharging its current through diode (D) into the output capacitor (C_{OUT}) at a rate of $(V_{OUT} - V_{IN})/L$. Thus, energy stored in the inductor during the switch on-time is transferred to the output during the switch off time. The output voltage is controlled by adjusting the peak switch current, as described in the section.

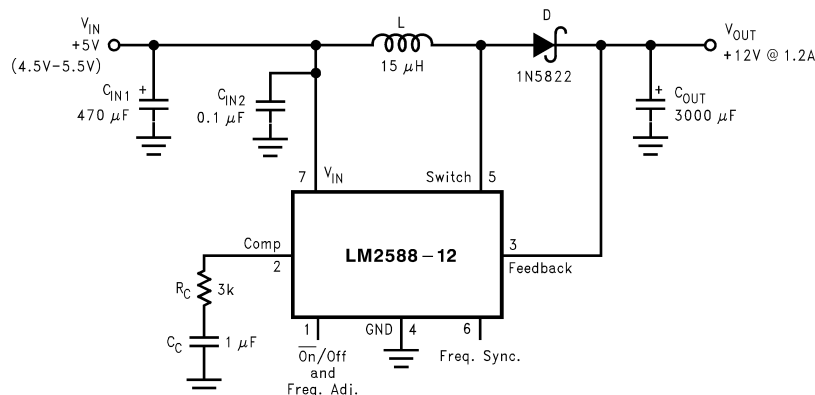
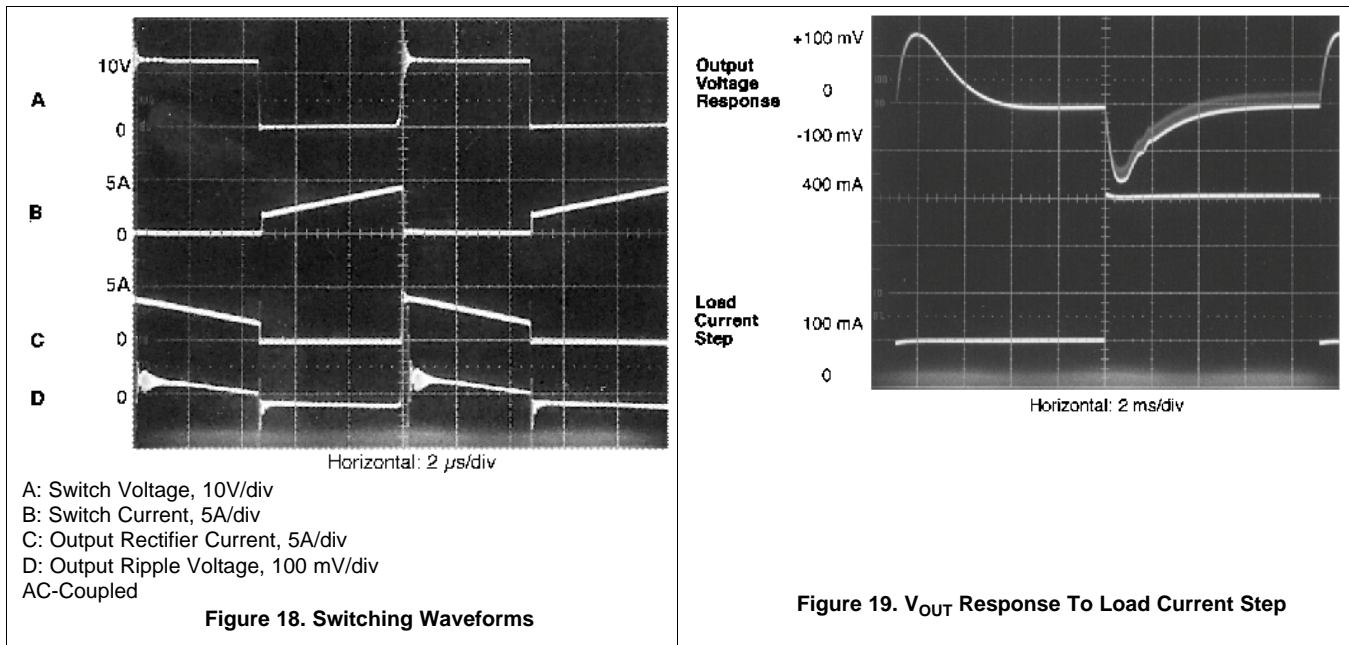

Figure 17. 12-V Boost Regulator

By adding a small number of external components (as shown in Figure 17), the LM2588 can be used to produce a regulated output voltage that is greater than the applied input voltage. The switching waveforms observed during the operation of this circuit are shown in . Typical performance of this regulator is shown in .

Feature Description (continued)



7.3.3 Shutdown Control

A feature of the LM2588 is its ability to be shut down using the $\overline{\text{ON}}$ /OFF pin (pin 1). This feature conserves input power by turning off the device when it is not in use. For proper operation, an isolation diode is required (as shown in Figure 20).

The device will shut down when 3 V or greater is applied on the $\overline{\text{ON}}$ /OFF pin, sourcing current into pin 1. In shut down mode, the device draws typically 56 μA of supply current (16 μA to V_{IN} and 40 μA to the $\overline{\text{ON}}$ /OFF pin). To turn the device back on, leave pin 1 floating, using an (isolation) diode, as shown in Figure 20 (for normal operation, do not source or sink current to or from this pin—see the next section).

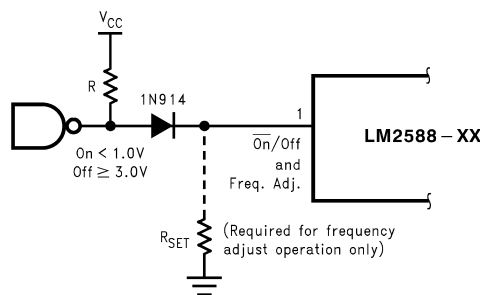

Figure 20. Shutdown Operation

7.3.4 Frequency Adjustment

The switching frequency of the LM2588 can be adjusted with the use of an external resistor. This feature allows the user to optimize the size of the magnetics and the output capacitor(s) by tailoring the operating frequency. A resistor connected from pin 1 (the Freq. Adj. pin) to ground will set the switching frequency from 100 kHz to 200 kHz (maximum). As shown in Figure 20, the pin can be used to adjust the frequency while still providing the shut down function. A curve in the Performance Characteristics Section graphs the resistor value to the corresponding switching frequency. The table in Table 1 shows resistor values corresponding to commonly used frequencies.

However, changing the LM2588's operating frequency from its nominal value of 100 kHz changes the magnetics selection and compensation component values.

Feature Description (continued)

Table 1. Frequency Setting Resistor Guide

R _{SET} (kΩ)	FREQUENCY (kHz)
Open	100
200	125
47	150
33	175
22	200

7.3.5 Frequency Synchronization

Another feature of the LM2588 is the ability to synchronize the switching frequency to an external source, using the sync pin (pin 6). This feature allows the user to parallel multiple devices to deliver more output power.

A negative falling pulse applied to the sync pin will synchronize the LM2588 to an external oscillator (see Figure 21 and Figure 22).

Use of this feature enables the LM2588 to be synchronized to an external oscillator, such as a system clock. This operation allows multiple power supplies to operate at the same frequency, thus eliminating frequency-related noise problems.

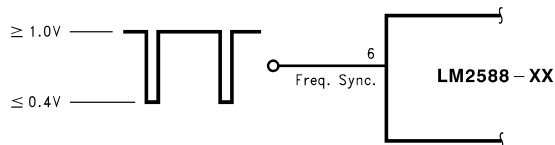

Figure 21. Frequency Synchronization

The scope photo in Figure 22 shows a LM2588 12V Boost Regulator synchronized to a 200-kHz signal. There is a 700 ns delay between the falling edge of the sync signal and the turning on of the switch.

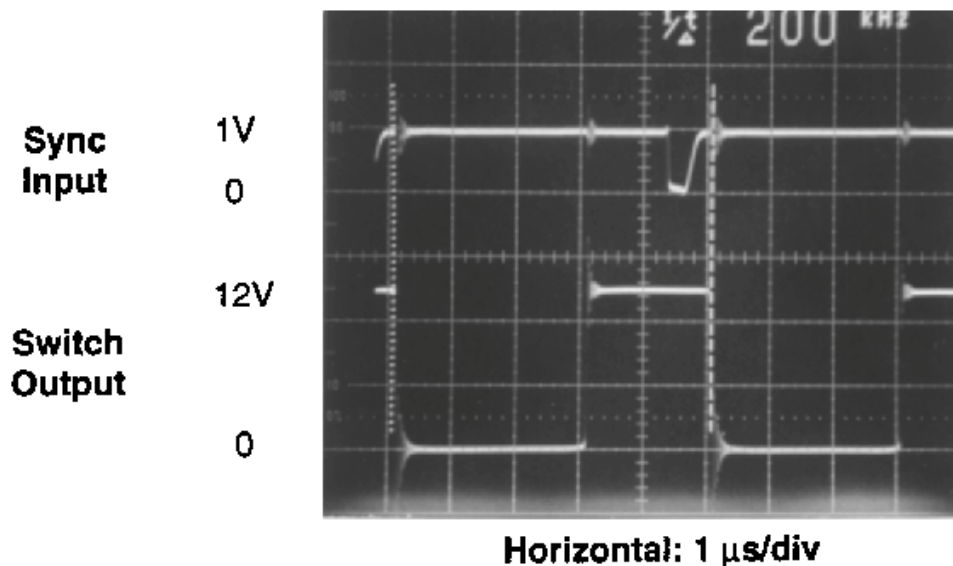

Figure 22. Waveforms Of A Synchronized 12-V Boost Regulator

7.3.6 Programming Output Voltage (Selecting R1 And R2)

Referring to the adjustable regulator in Figure 23, the output voltage is programmed by the resistors R1 and R2 by the following formula:

$$V_{OUT} = V_{REF} (1 + R1/R2) \quad \text{where } V_{REF} = 1.23V \quad (1)$$

Resistors R1 and R2 divide the output voltage down so that it can be compared with the 1.23-V internal reference. With R2 between 1k and 5k, R1 is:

$$R1 = R2 (V_{OUT}/V_{REF} - 1) \quad \text{where}$$

where

- $e V_{REF} = 1.23 V$ (2)

For best temperature coefficient and stability with time, use 1% metal film resistors.

7.3.7 Short-Circuit Condition

Due to the inherent nature of boost regulators, when the output is shorted (see Figure 23), current flows directly from the input, through the inductor and the diode, to the output, bypassing the switch. The current limit of the switch *does not* limit the output current for the entire circuit. To protect the load and prevent damage to the switch, the current must be externally limited, either by the input supply or at the output with an external current limit circuit. The external limit should be set to the maximum switch current of the device, which is 5 A.

In a flyback regulator application (Figure 24), using the standard transformers, the LM2588 survives a short circuit to the main output. When the output voltage drops to 80% of its nominal value, the frequency will drop to 25 kHz. With a lower frequency, off times are larger. With the longer off times, the transformer can release all of its stored energy before the switch turns back on. Hence, the switch turns on initially with zero current at its collector. In this condition, the switch current limit will limit the peak current, saving the device.

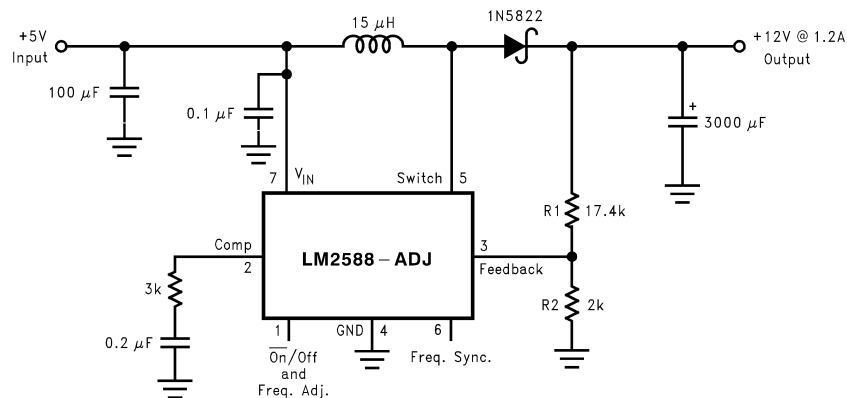

Figure 23. Boost Regulator

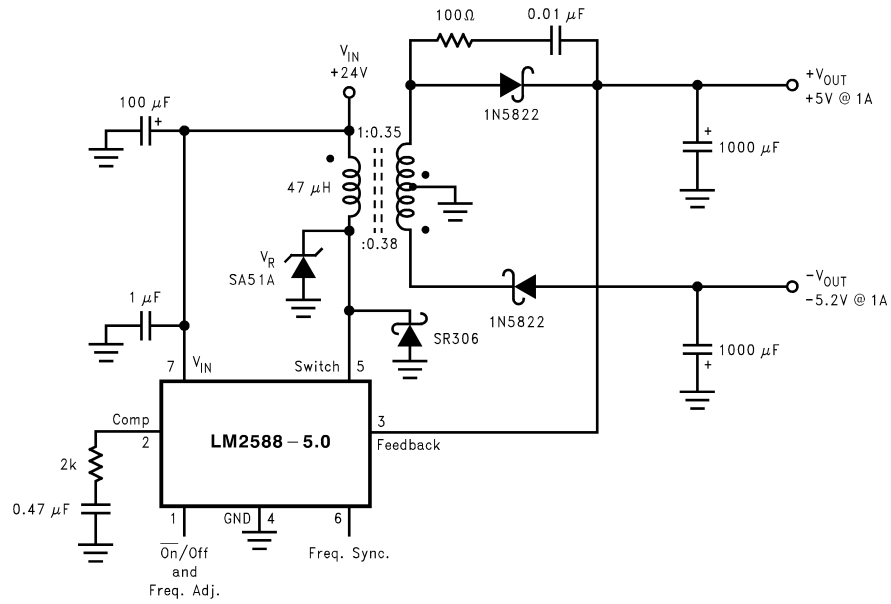

Figure 24. Flyback Regulator

8 Application and Implementation

NOTE

Information in the following applications sections is not part of the TI component specification, and TI does not warrant its accuracy or completeness. TI's customers are responsible for determining suitability of components for their purposes. Customers should validate and test their design implementation to confirm system functionality.

8.1 Application Information

The LM2586 series of regulators are monolithic integrated circuits specifically designed for flyback, step-up (boost), and forward converter applications. Requiring a minimum number of external components, these regulators are cost effective, and simple to use. Included in the datasheet are typical circuits of boost and flyback regulators. Also listed are selector guides for diodes and capacitors and a family of standard inductors and flyback transformers designed to work with these switching regulators.

8.2 Typical Applications

8.2.1 Typical Flyback Regulator Applications

Figure 25 through Figure 30 show six typical flyback applications, varying from single output to triple output. Each drawing contains the part number(s) and manufacturer(s) for every component except the transformer. For the transformer part numbers and manufacturers' names, see Table 2. For applications with different output voltages—requiring the LM2588-ADJ—or different output configurations that do not match the standard configurations, refer to the *Switchers Made Simple* software.

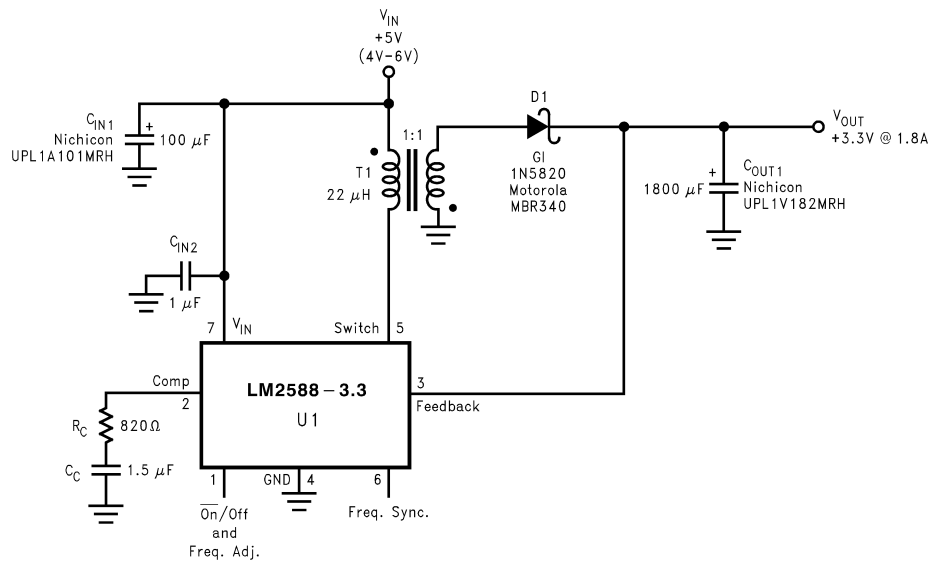

Figure 25. Single-Output Flyback Regulator

Typical Applications (continued)

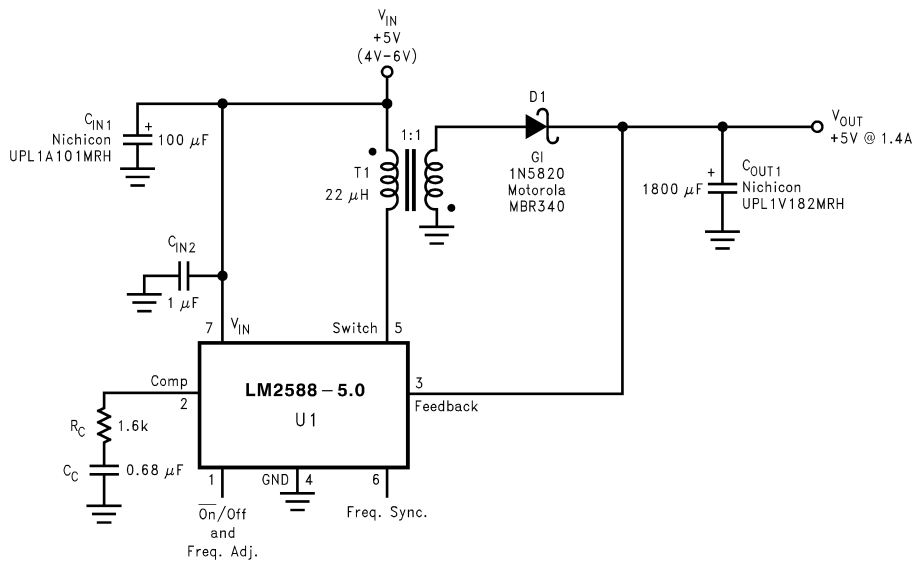

Figure 26. Single-Output Flyback Regulator

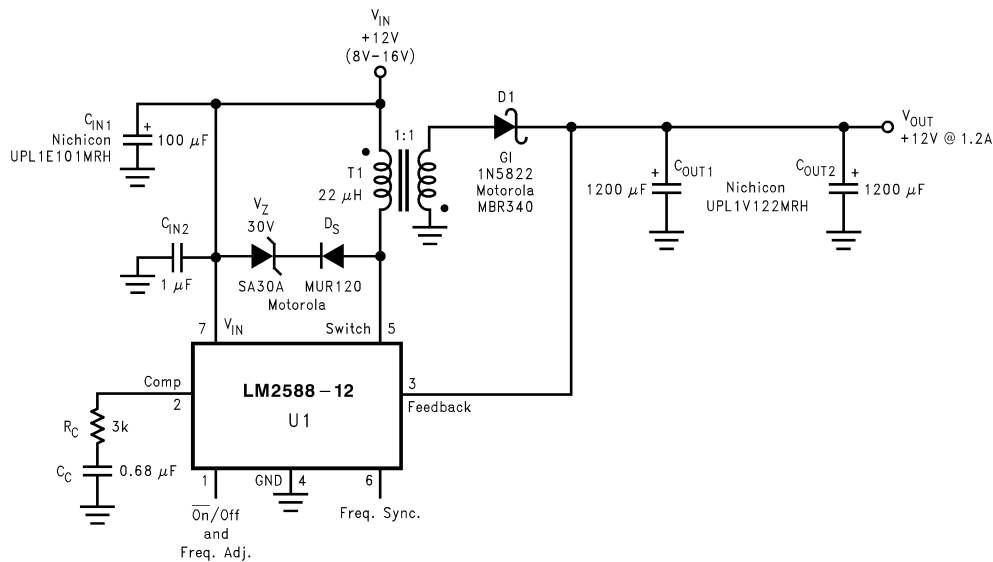

Figure 27. Single-Output Flyback Regulator

Typical Applications (continued)

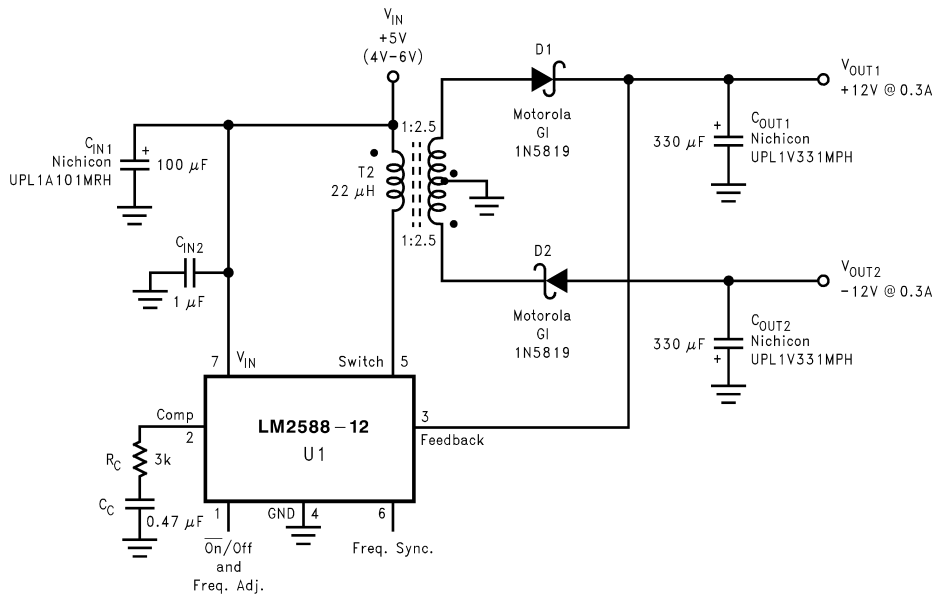

Figure 28. Dual-Output Flyback Regulator

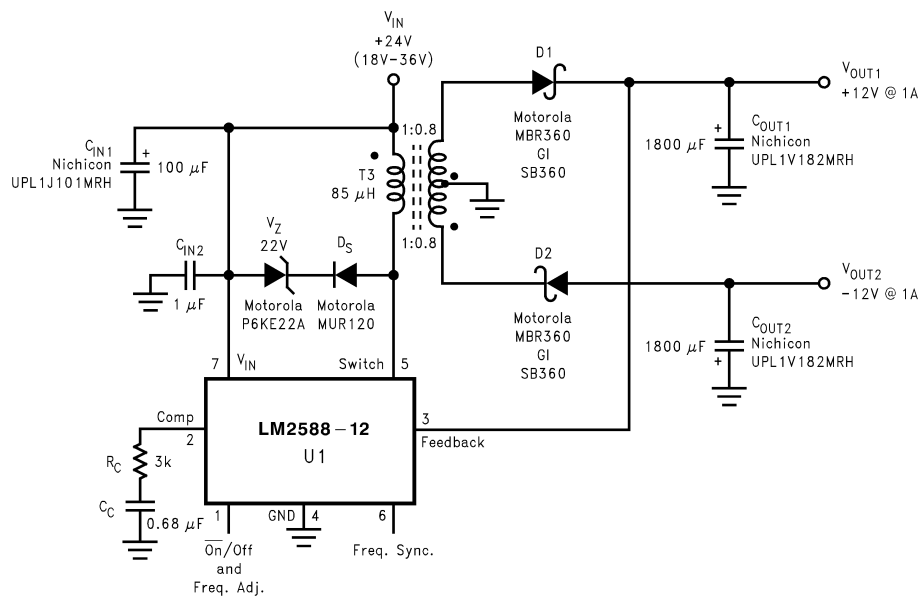

Figure 29. Dual-Output Flyback Regulator

Typical Applications (continued)

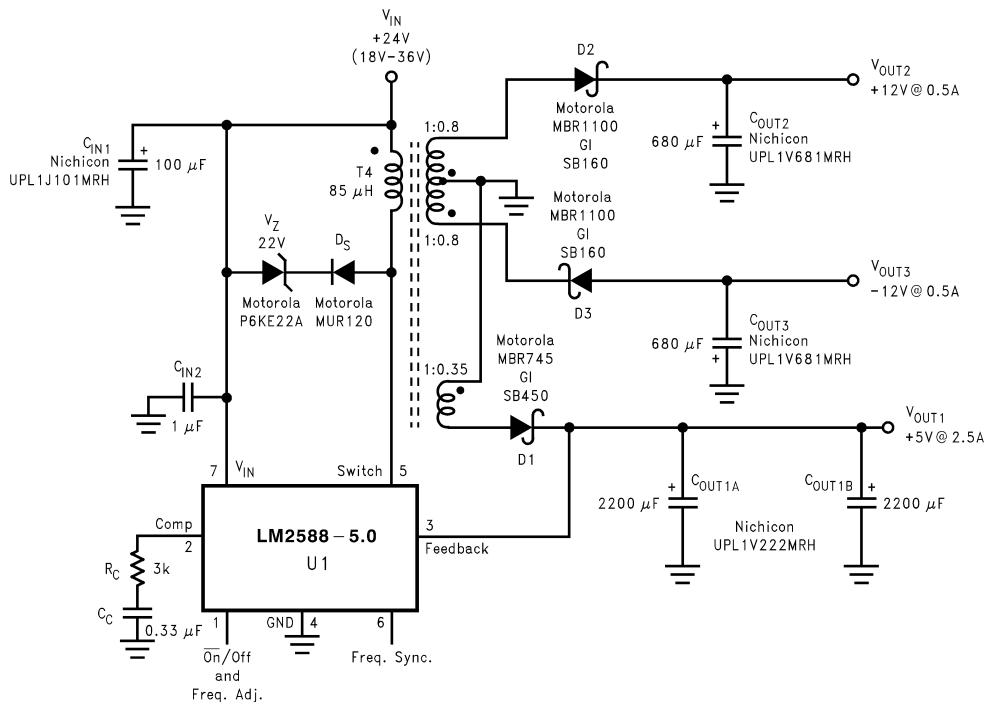

Figure 30. Triple-Output Flyback Regulator

8.2.1.1 Design Requirements

8.2.1.1.1 Transformer Selection (T)

Table 2 lists the standard transformers available for flyback regulator applications. Included in the table are the turns ratio(s) for each transformer, as well as the output voltages, input voltage ranges, and the maximum load currents for each circuit.

Table 2. Transformer Selection Table

APPLICATIONS	Figure 25	Figure 26	Figure 27	Figure 28	Figure 29	Figure 30
Transformers	T1	T1	T1	T2	T3	T4
V _{IN}	4V–6V	4V–6V	8V–16V	4V–6V	18V–36V	18V–36V
V _{OUT1}	3.3V	5V	12V	12V	12V	5V
I _{OUT1} (Max)	1.8A	1.4A	1.2A	0.3A	1A	2.5A
N ₁	1	1	1	2.5	0.8	0.35
V _{OUT2}				-12V	-12V	12V
I _{OUT2} (Max)				0.3A	1A	0.5A
N ₂				2.5	0.8	0.8
V _{OUT3}						-12V
I _{OUT3} (Max)						0.5A
N ₃						0.8

Table 3. Transformer Manufacturer Guide

Transformer Type	Manufacturers' Part Numbers				
	Coilcraft ⁽¹⁾	Coilcraft Surface Mount ⁽¹⁾	Pulse Surface Mount ⁽²⁾	Renco ⁽³⁾	Schott ⁽⁴⁾
T1	Q4434-B	Q4435-B	PE-68411	RL-5530	67141450
T2	Q4337-B	Q4436-B	PE-68412	RL-5531	67140860
T3	Q4343-B	—	PE-68421	RL-5534	67140920
T4	Q4344-B	—	PE-68422	RL-5535	67140930

- (1) Coilcraft Inc.: Phone: (800) 322-2645 1102 Silver Lake Road, Cary, IL 60013: Fax: (708) 639-1469 European Headquarters, 21 Napier Place: Phone: +44 1236 730 595 Wardpark North, Cumbernauld, Scotland G68 0LL: Fax: +44 1236 730 627
- (2) Pulse Engineering Inc.: Phone: (619) 674-8100 12220 World Trade Drive, San Diego, CA 92128: Fax: (619) 674-8262 European Headquarters, Dunmore Road: Phone: +353 93 24 107 Tuam, Co. Galway, Ireland: Fax: +353 93 24 459
- (3) Renco Electronics Inc.: Phone: (800) 645-5828 60 Jeffryn Blvd. East, Deer Park, NY 11729: Fax: (516) 586-5562
- (4) Schott Corp.: Phone: (612) 475-1173 1000 Parkers Lane Road, Wayzata, MN 55391: Fax: (612) 475-1786

8.2.1.1.2 Transformer Footprints

Figure 31 through Figure 48 show the footprints of each transformer, listed in Table 3.

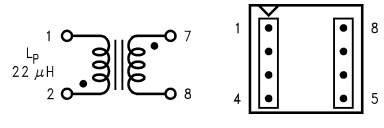
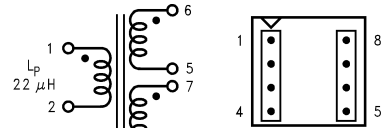
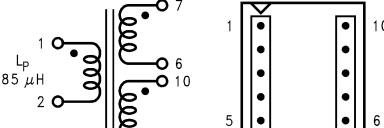
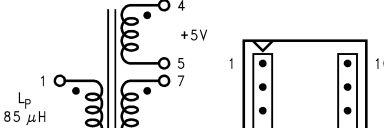
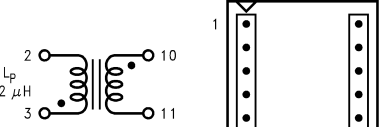
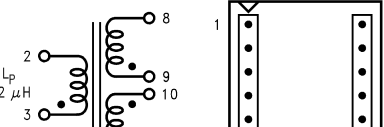
 <p>Figure 31. T1 - Top View Coilcraft Q4434-B</p>	 <p>Figure 32. T2 - Top View Coilcraft Q4337-B</p>
 <p>Figure 33. T3 - Top View Coilcraft Q4343-B</p>	 <p>Figure 34. T4 - Top View Coilcraft Q4344-B</p>
 <p>Figure 35. T1 - Top View Coilcraft Q4435-B (Surface Mount)</p>	 <p>Figure 36. T2 - Top View Coilcraft Q4436-B (Surface Mount)</p>

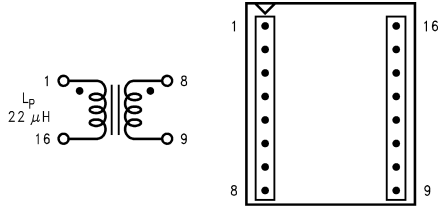

Figure 37. T1 - Top View
Pulse PE-68411
(Surface Mount)

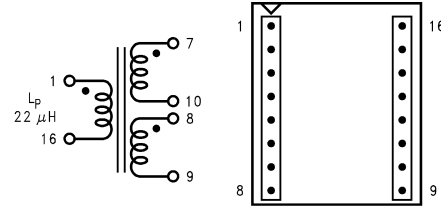

Figure 38. T2 - Top View
Pulse PE-68412
(Surface Mount)

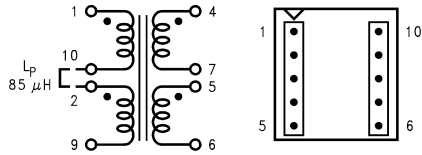

Figure 39. T3 - Top View
Pulse PE-68421
(Surface Mount)

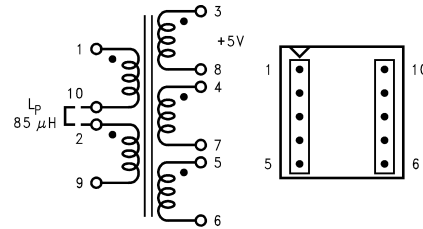

Figure 40. T4 - Top View
Pulse PE-68422
(Surface Mount)

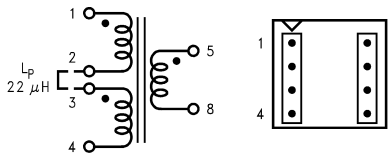

Figure 41. T1 - Top View
Renco RL-5530

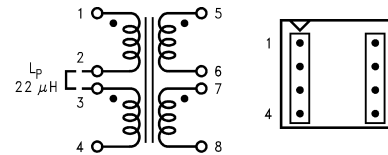

Figure 42. T2 - Top View
Renco RL-5531

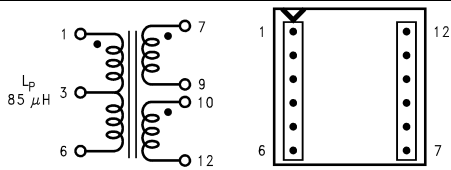

Figure 43. T3 - Top View
Renco RL-5534

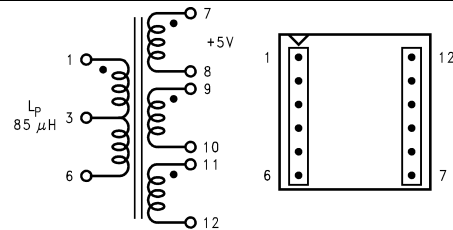

Figure 44. T4 - Top View
Renco RL-5535

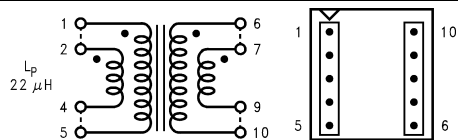

Figure 45. T1 - Top View
Schott 67141450

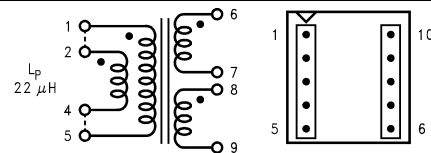

Figure 46. T2 - Top View
Schott 67140860

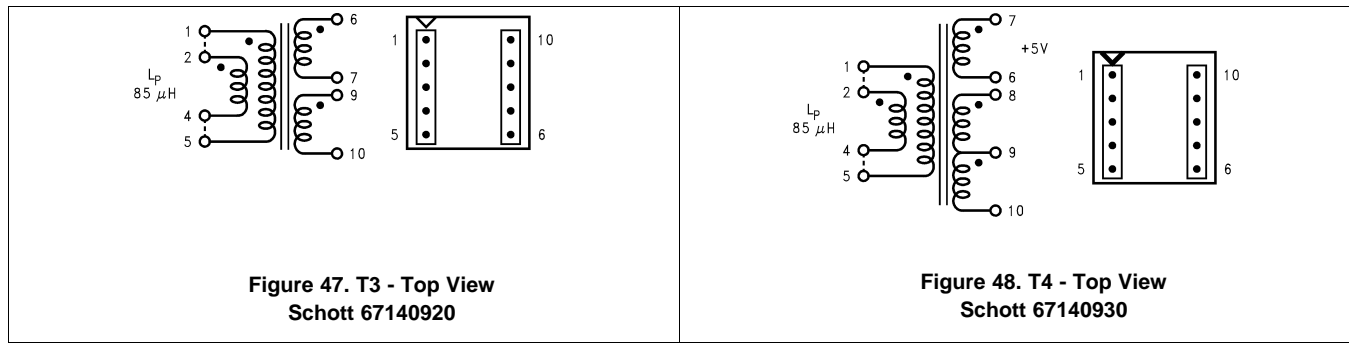

Figure 47. T3 - Top View
Schott 67140920

Figure 48. T4 - Top View
Schott 67140930

8.2.1.2 Detailed Design Procedure

8.2.1.2.1 Custom Design With WEBENCH® Tools

[Click here](#) to create a custom design using the LM2588 device with the WEBENCH® Power Designer.

1. Start by entering the input voltage (V_{IN}), output voltage (V_{OUT}), and output current (I_{OUT}) requirements.
2. Optimize the design for key parameters such as efficiency, footprint, and cost using the optimizer dial.
3. Compare the generated design with other possible solutions from Texas Instruments.

The WEBENCH Power Designer provides a customized schematic along with a list of materials with real-time pricing and component availability.

In most cases, these actions are available:

- Run electrical simulations to see important waveforms and circuit performance
- Run thermal simulations to understand board thermal performance
- Export customized schematic and layout into popular CAD formats
- Print PDF reports for the design, and share the design with colleagues

Get more information about WEBENCH tools at www.ti.com/WEBENCH.

8.2.1.2.2 Flyback Regulator Input Capacitors

A flyback regulator draws discontinuous pulses of current from the input supply. Therefore, there are two input capacitors needed in a flyback regulator—one for energy storage and one for filtering (see [Figure 24](#)). Both are required due to the inherent operation of a flyback regulator. To keep a stable or constant voltage supply to the LM2588, a storage capacitor ($\geq 100 \mu\text{F}$) is required. If the input source is a rectified DC supply and/or the application has a wide temperature range, the required rms current rating of the capacitor might be very large. This means a larger value of capacitance or a higher voltage rating will be needed for the input capacitor. The storage capacitor will also attenuate noise which may interfere with other circuits connected to the same input supply voltage.

In addition, a small bypass capacitor is required due to the noise generated by the input current pulses. To eliminate the noise, insert a 1- μF ceramic capacitor between V_{IN} and ground as close as possible to the device.

8.2.1.2.3 Switch Voltage Limits

In a flyback regulator, the maximum steady-state voltage appearing at the switch, when it is off, is set by the transformer turns ratio, N , the output voltage, V_{OUT} , and the maximum input voltage, V_{IN} (maximum):

$$V_{SW(OFF)} = V_{IN} (\text{max}) + (V_{OUT} + V_F) / N$$

where

- V_F is the forward biased voltage of the output diode, and is typically 0.5 V for Schottky diodes and 0.8V for ultra-fast recovery diodes (3)

In certain circuits, there exists a voltage spike, V_{LL} , superimposed on top of the steady-state voltage (see Figure 18, waveform A). Usually, this voltage spike is caused by the transformer leakage inductance and/or the output rectifier recovery time. To “clamp” the voltage at the switch from exceeding its maximum value, a transient suppressor in series with a diode is inserted across the transformer primary (as shown in the circuit in Figure 16 and other flyback regulator circuits throughout the datasheet). The schematic in Figure 24 shows another method of clamping the switch voltage. A single voltage transient suppressor (the SA51A) is inserted at the switch pin. This method clamps the total voltage across the switch, not just the voltage across the primary.

If poor circuit layout techniques are used (see the section), negative voltage transients may appear on the Switch pin (pin 5). Applying a negative voltage (with respect to the IC's ground) to any monolithic IC pin causes erratic and unpredictable operation of that IC. This holds true for the LM2588 IC as well. When used in a flyback regulator, the voltage at the Switch pin (pin 5) can go negative when the switch turns on. The “ringing” voltage at the switch pin is caused by the output diode capacitance and the transformer leakage inductance forming a resonant circuit at the secondary(ies). The resonant circuit generates the “ringing” voltage, which gets reflected back through the transformer to the switch pin. There are two common methods to avoid this problem. One is to add an RC snubber around the output rectifier(s), as in Figure 24. The values of the resistor and the capacitor must be chosen so that the voltage at the Switch pin does not drop below -0.4 V. The resistor may range in value between 10Ω and 1 k Ω , and the capacitor will vary from 0.001 μ F to 0.1 μ F. Adding a snubber will (slightly) reduce the efficiency of the overall circuit.

The other method to reduce or eliminate the “ringing” is to insert a Schottky diode clamp between pins 5 and 4 (ground), also shown in Figure 24. This prevents the voltage at pin 5 from dropping below -0.4 V. The reverse voltage rating of the diode must be greater than the switch off voltage.

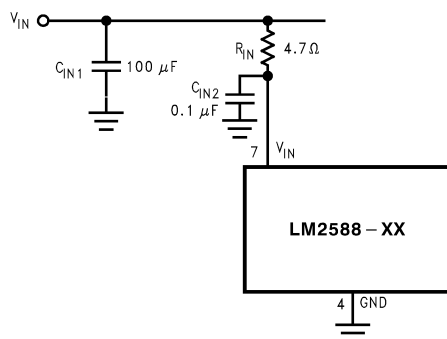

Figure 49. Input Line Filter

8.2.1.2.4 Output Voltage Limitations

The maximum output voltage of a boost regulator is the maximum switch voltage minus a diode drop. In a flyback regulator, the maximum output voltage is determined by the turns ratio, N , and the duty cycle, D , by the equation:

$$V_{OUT} \approx N \times V_{IN} \times D / (1 - D) \quad (4)$$

The duty cycle of a flyback regulator is determined by the following equation:

$$D = \frac{V_{OUT} + V_F}{N(V_{IN} - V_{SAT}) + V_{OUT} + V_F} \approx \frac{V_{OUT}}{N(V_{IN}) + V_{OUT}} \quad (5)$$

Theoretically, the maximum output voltage can be as large as desired—just keep increasing the turns ratio of the transformer. However, there exists some physical limitations that prevent the turns ratio, and thus the output voltage, from increasing to infinity. The physical limitations are capacitances and inductances in the LM2588 switch, the output diode(s), and the transformer—such as reverse recovery time of the output diode (mentioned above).

8.2.1.2.5 Noisy Input Line Condition

A small, low-pass RC filter should be used at the input pin of the LM2588 if the input voltage has an unusually large amount of transient noise, such as with an input switch that bounces. The circuit in [Figure 49](#) demonstrates the layout of the filter, with the capacitor placed from the input pin to ground and the resistor placed between the input supply and the input pin. Note that the values of R_{IN} and C_{IN} shown in the schematic are good enough for most applications, but some readjusting might be required for a particular application. If efficiency is a major concern, replace the resistor with a small inductor (say 10 μ H and rated at 200 mA).

8.2.1.2.6 Stability

All current-mode controlled regulators can suffer from an instability, known as subharmonic oscillation, if they operate with a duty cycle above 50%. To eliminate subharmonic oscillations, a minimum value of inductance is required to ensure stability for all boost and flyback regulators. The minimum inductance is given by:

$$L(\text{Min}) = \frac{2.92 [(V_{IN}(\text{Min}) - V_{SAT}) \cdot (2D(\text{Max}) - 1)]}{1 - D(\text{Max})} (\mu\text{H})$$

where

- V_{SAT} is the switch saturation voltage and can be found in [Typical Characteristics](#) (6)

8.2.2 Typical Boost Regulator Applications

[Figure 50](#) and [Figure 51](#) through [Figure 53](#) show four typical boost applications—one fixed and three using the adjustable version of the LM2588. Each drawing contains the part number(s) and manufacturer(s) for every component. For the fixed 12-V output application, the part numbers and manufacturers' names for the inductor are listed in a table in [Table 4](#). For applications with different output voltages, refer to the *Switchers Made Simple™ software*.

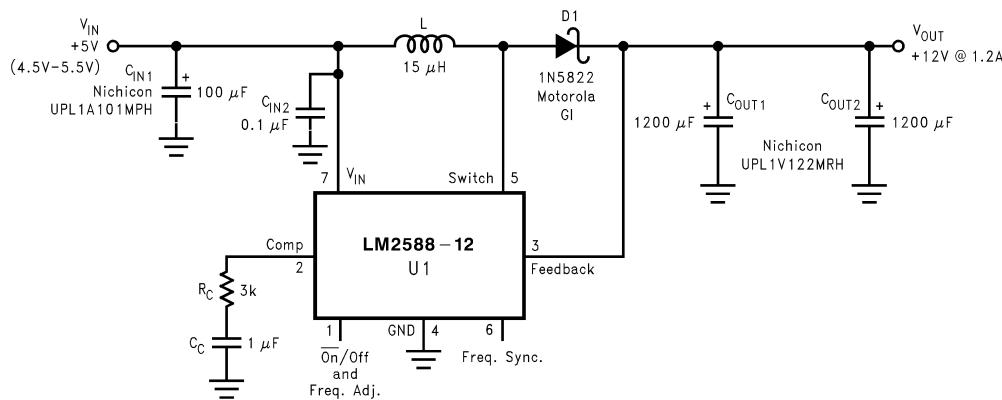

Figure 50. 5-V to 12-V Boost Regulator

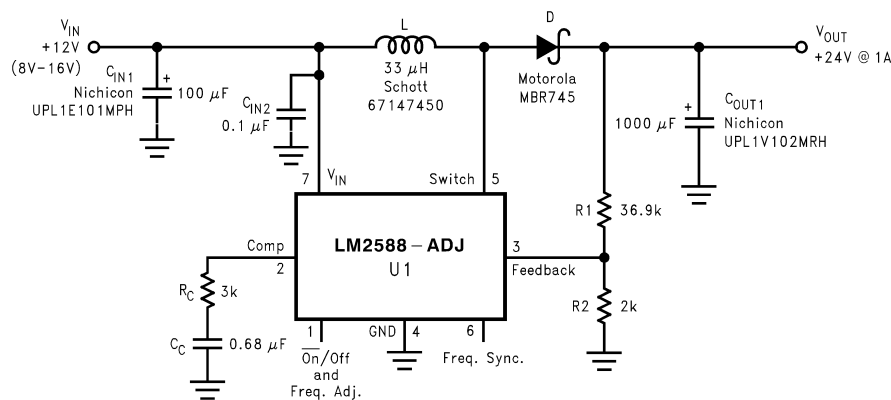

Figure 51. 12-V to 24-V Boost Regulator

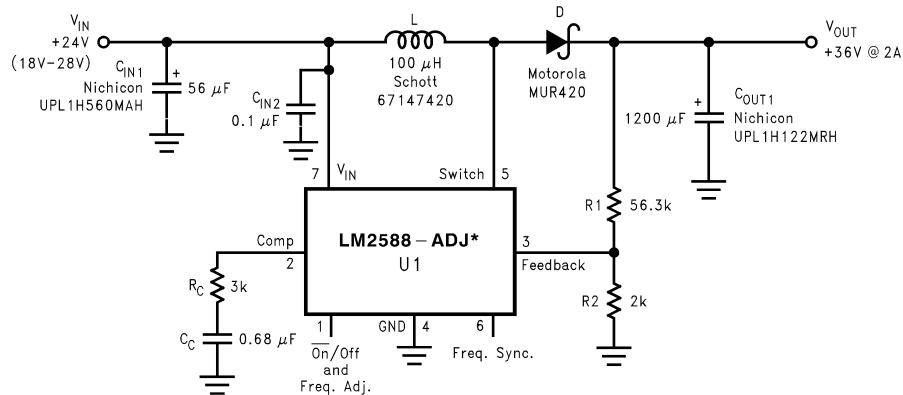
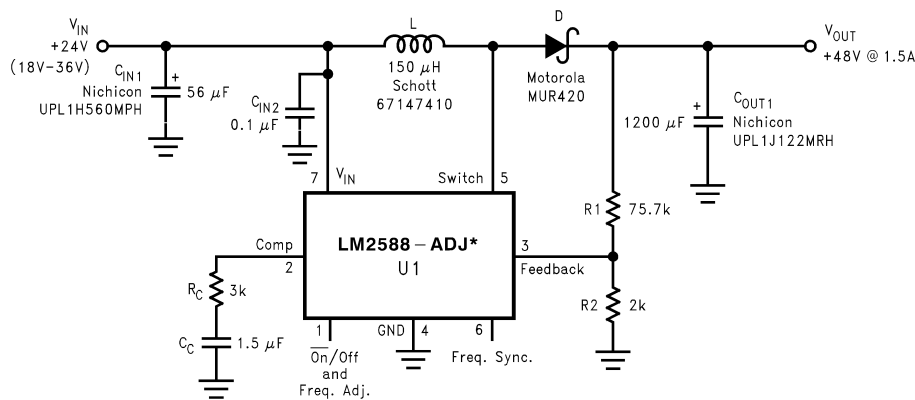

Figure 52. 24-V to 36-V Boost Regulator



*The LM2588 requires a heat sink in these applications. The size of the heat sink will depend on the maximum ambient temperature. To calculate the thermal resistance of the IC and the size of the heat sink needed, see the [Heat Sink/Thermal Considerations](#) section in [Layout](#).

Figure 53. 24-V to 48-V Boost Regulator

8.2.2.1 Design Requirements

Table 4 contains a table of standard inductors, by part number and corresponding manufacturer, for the fixed output regulator of Figure 50.

Table 4. Inductor Selection Table

Coilcraft ⁽¹⁾	Pulse ⁽²⁾	Renco ⁽³⁾	Schott ⁽⁴⁾
R4793-A	PE-53900	RL-5472-5	67146520

- (1) Coilcraft Inc., Phone: (800) 322-2645 1102 Silver Lake Road, Cary, IL 60013: Fax: (708) 639-1469 European Headquarters, 21 Napier Place: Phone: +44 1236 730 595 Wardpark North, Cumbernauld, Scotland G68 0LL: Fax: +44 1236 730 627
- (2) Pulse Engineering Inc., Phone: (619) 674-8100 12220 World Trade Drive, San Diego, CA 92128: Fax: (619) 674-8262 European Headquarters, Dunmore Road: Phone: +353 93 24 107 Tuam, Co. Galway, Ireland: Fax: +353 93 24 459
- (3) Renco Electronics Inc., Phone: (800) 645-5828 60 Jeffryn Blvd. East, Deer Park, NY 11729: Fax: (516) 586-5562
- (4) Schott Corp., Phone: (612) 475-1173 1000 Parkers Lane Road, Wayzata, MN 55391: Fax: (612) 475-1786

8.2.2.2 Detailed Design Procedure

See [Detailed Design Procedure](#)

8.3 System Examples

8.3.1 Test Circuits

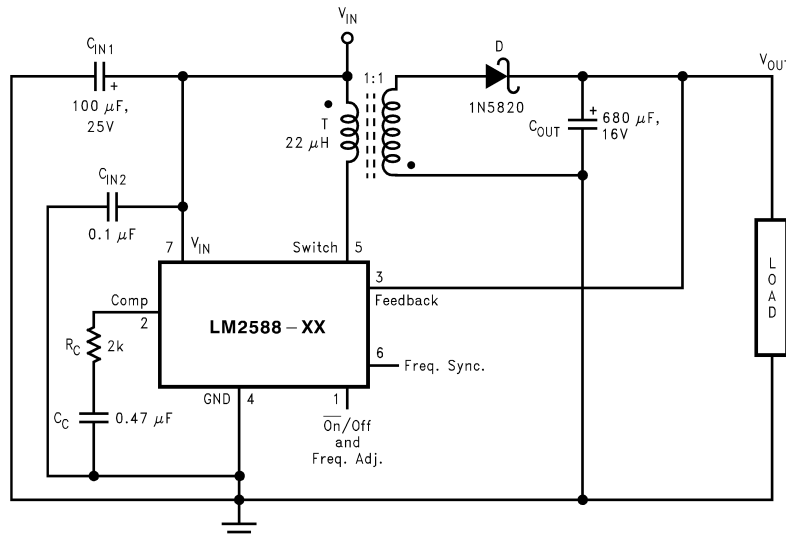

C_{IN1} —100 μ F, 25V Aluminum Electrolytic C_{IN2} —0.1 μ F Ceramic T —22 μ H, 1:1 Schott #67141450D—1N5820 C_{OUT} —680 μ F, 16V Aluminum Electrolytic C_C —0.47 μ F Ceramic R_C —2k

Figure 54. 3.3-V and 5-V LM2588

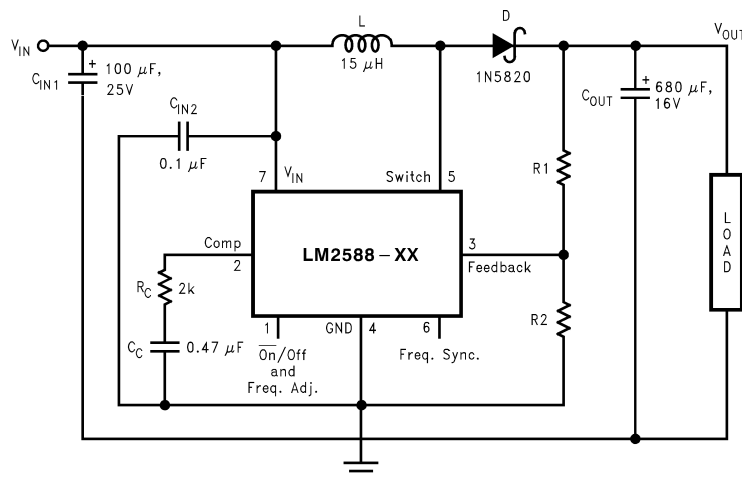

C_{IN1} —100 μ F, 25V Aluminum Electrolytic C_{IN2} —0.1 μ F Ceramic L —15 μ H, Renco #RL-5472-5D—1N5820 C_{OUT} —680 μ F, 16V Aluminum Electrolytic C_C —0.47 μ F Ceramic R_C —2k For 12V Devices: R1 = Short (0 Ω) and R2 = Open For ADJ Devices: R1 = 48.75k, \pm 0.1% and R2 = 5.62k, \pm 0.1%

Figure 55. 12-V and Adjustable LM2588

9 Layout

9.1 Layout Guidelines

As in any switching regulator, layout is very important. Rapidly switching currents associated with wiring inductance generate voltage transients which can cause problems. For minimal inductance and ground loops, keep the length of the leads and traces as short as possible. Use single point grounding or ground plane construction for best results. Separate the signal grounds from the power grounds (as indicated in Figure 56). When using the Adjustable version, physically locate the programming resistors as near the regulator IC as possible, to keep the sensitive feedback wiring short.

9.2 Layout Example

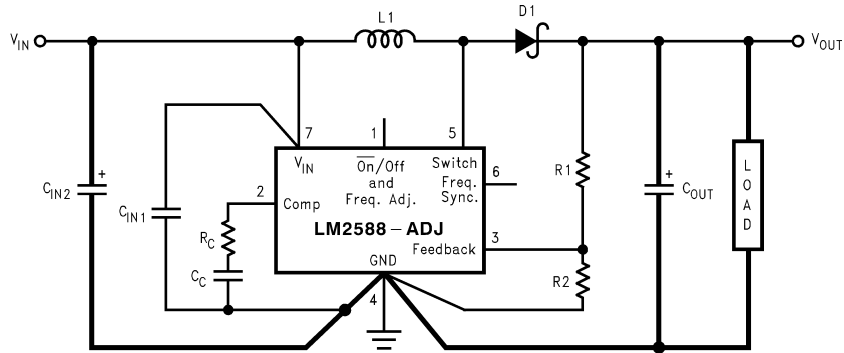

Figure 56. Circuit Board Layout

9.3 Heat Sink/Thermal Considerations

In many cases, a heat sink is not required to keep the LM2588 junction temperature within the allowed operating temperature range. For each application, to determine whether or not a heat sink will be required, the following must be identified:

- 1) Maximum ambient temperature (in the application).
- 2) Maximum regulator power dissipation (in the application).
- 3) Maximum allowed junction temperature (125°C for the LM2588). For a safe, conservative design, a temperature approximately 15°C cooler than the maximum junction temperature should be selected (110°C).
- 4) LM2588 package thermal resistances θ_{JA} and θ_{JC} (given in the Electrical Characteristics).

Total power dissipated (P_D) by the LM2588 can be estimated as follows:

Boost:

$$P_D = 0.15\Omega \cdot \left(\frac{I_{LOAD}}{1-D} \right)^2 \cdot D + \frac{I_{LOAD}}{50 \cdot (1-D)} \cdot D \cdot V_{IN}$$

Flyback:

$$P_D = 0.15\Omega \cdot \left(\frac{N \cdot \sum I_{LOAD}}{1-D} \right)^2 \cdot D + \frac{N \cdot \sum I_{LOAD}}{50 \cdot (1-D)} \cdot D \cdot V_{IN}$$

(7)

V_{IN} is the minimum input voltage, V_{OUT} is the output voltage, N is the transformer turns ratio, D is the duty cycle, and I_{LOAD} is the maximum load current (and $\sum I_{LOAD}$ is the sum of the maximum load currents for multiple-output flyback regulators). The duty cycle is given by:

Boost:

Heat Sink/Thermal Considerations (continued)

$$D = \frac{V_{OUT} + V_F - V_{IN}}{V_{OUT} + V_F - V_{SAT}} \approx \frac{V_{OUT} - V_{IN}}{V_{OUT}}$$

Flyback:

$$D = \frac{V_{OUT} + V_F}{N(V_{IN} - V_{SAT}) + V_{OUT} + V_F} \approx \frac{V_{OUT}}{N(V_{IN}) + V_{OUT}}$$

where

- V_F is the forward biased voltage of the diode and is typically 0.5V for Schottky diodes and 0.8V for fast recovery diodes
- V_{SAT} is the switch saturation voltage and can be found in the Characteristic Curves. (8)

When no heat sink is used, the junction temperature rise is:

$$\Delta T_J = P_D \cdot \theta_{JA} \quad (9)$$

Adding the junction temperature rise to the maximum ambient temperature gives the actual operating junction temperature:

$$T_J = \Delta T_J + T_A \quad (10)$$

If the operating junction temperature exceeds the maximum junction temperature in item 3 above, then a heat sink is required. When using a heat sink, the junction temperature rise can be determined by the following:

$$\Delta T_J = P_D \cdot (\theta_{JC} + \theta_{Interface} + \theta_{Heat\ Sink}) \quad (11)$$

Again, the operating junction temperature will be:

$$T_J = \Delta T_J + T_A \quad (12)$$

As before, if the maximum junction temperature is exceeded, a larger heat sink is required (one that has a lower thermal resistance).

Included in the *Switchers Made Simple*[™] design software is a more precise (non-linear) thermal model that can be used to determine junction temperature with different input-output parameters or different component values. It can also calculate the heat sink thermal resistance required to maintain the regulator junction temperature below the maximum operating temperature.

10 器件和文档支持

10.1 器件支持

10.1.1 第三方产品免责声明

TI 发布的与第三方产品或服务有关的信息，不能构成与此类产品或服务或保修的适用性有关的认可，不能构成此类产品或服务单独或与任何 TI 产品或服务一起的表示或认可。

10.1.2 开发支持

10.1.2.1 使用 **WEBENCH®** 工具创建定制设计

单击[此处](#)，使用 LM2586 器件并借助 WEBENCH® 电源设计器创建定制设计方案。

1. 首先输入输入电压 (V_{IN})、输出电压 (V_{OUT}) 和输出电流 (I_{OUT}) 要求。
2. 使用优化器拨盘优化该设计的关键参数，如效率、尺寸和成本。
3. 将生成的设计与德州仪器 (TI) 的其他可行的解决方案进行比较。

WEBENCH 电源设计器可提供定制原理图以及罗列实时价格和组件供货情况的物料清单。

在多数情况下，可执行以下操作：

- 运行电气仿真，观察重要波形以及电路性能
- 运行热性能仿真，了解电路板热性能
- 将定制原理图和布局方案以常用 CAD 格式导出
- 打印设计方案的 PDF 报告并与同事共享

有关 WEBENCH 工具的详细信息，请访问 www.ti.com.cn/WEBENCH。

10.2 接收文档更新通知

要接收文档更新通知，请导航至 TI.com.cn 上的器件产品文件夹。单击右上角的 [通知我](#) 进行注册，即可每周接收产品信息更改摘要。有关更改的详细信息，请查看任何已修订文档中包含的修订历史记录。

10.3 社区资源

The following links connect to TI community resources. Linked contents are provided "AS IS" by the respective contributors. They do not constitute TI specifications and do not necessarily reflect TI's views; see TI's [Terms of Use](#).

TI E2E™ Online Community *TI's Engineer-to-Engineer (E2E) Community*. Created to foster collaboration among engineers. At e2e.ti.com, you can ask questions, share knowledge, explore ideas and help solve problems with fellow engineers.

Design Support *TI's Design Support* Quickly find helpful E2E forums along with design support tools and contact information for technical support.

10.4 商标

Switchers Made Simple, E2E are trademarks of Texas Instruments.

WEBENCH is a registered trademark of Texas Instruments.

Switchers Made Simple is a registered trademark of dcl_owner.

All other trademarks are the property of their respective owners.

10.5 静电放电警告



ESD 可能会损坏该集成电路。德州仪器 (TI) 建议通过适当的预防措施处理所有集成电路。如果不遵守正确的处理措施和安装程序，可能会损坏集成电路。

ESD 的损坏小至导致微小的性能降级，大至整个器件故障。精密的集成电路可能更容易受到损坏，这是因为非常细微的参数更改都可能会导致器件与其发布的规格不相符。

10.6 Glossary

[SLYZ022](#) — *TI Glossary*.

This glossary lists and explains terms, acronyms, and definitions.

11 机械、封装和可订购信息

以下页面包含机械、封装和可订购信息。这些信息是指定器件的最新可用数据。数据如有变更，恕不另行通知，且不会对此文档进行修订。如需获取此数据表的浏览器版本，请查阅左侧的导航栏。

PACKAGING INFORMATION

Orderable Device	Status (1)	Package Type	Package Drawing	Pins	Package Qty	Eco Plan (2)	Lead finish/ Ball material (6)	MSL Peak Temp (3)	Op Temp (°C)	Device Marking (4/5)	Samples
LM2588S-12/NOPB	ACTIVE	DDPAK/ TO-263	KTW	7	45	RoHS-Exempt & Green	SN	Level-3-245C-168 HR	-40 to 125	LM2588S -12 P+	Samples
LM2588S-3.3/NOPB	ACTIVE	DDPAK/ TO-263	KTW	7	45	RoHS-Exempt & Green	SN	Level-3-245C-168 HR	-40 to 125	LM2588S -3.3 P+	Samples
LM2588S-5.0/NOPB	ACTIVE	DDPAK/ TO-263	KTW	7	45	RoHS-Exempt & Green	SN	Level-3-245C-168 HR	-40 to 125	LM2588S -5.0 P+	Samples
LM2588S-ADJ	NRND	DDPAK/ TO-263	KTW	7	45	Non-RoHS & Green	Call TI	Level-3-235C-168 HR	-40 to 125	LM2588S -ADJ P+	
LM2588S-ADJ/NOPB	ACTIVE	DDPAK/ TO-263	KTW	7	45	RoHS-Exempt & Green	SN	Level-3-245C-168 HR	-40 to 125	LM2588S -ADJ P+	Samples
LM2588SX-12/NOPB	ACTIVE	DDPAK/ TO-263	KTW	7	500	RoHS-Exempt & Green	SN	Level-3-245C-168 HR	-40 to 125	LM2588S -12 P+	Samples
LM2588SX-3.3/NOPB	ACTIVE	DDPAK/ TO-263	KTW	7	500	RoHS-Exempt & Green	SN	Level-3-245C-168 HR	-40 to 125	LM2588S -3.3 P+	Samples
LM2588SX-5.0/NOPB	ACTIVE	DDPAK/ TO-263	KTW	7	500	RoHS-Exempt & Green	SN	Level-3-245C-168 HR	-40 to 125	LM2588S -5.0 P+	Samples
LM2588SX-ADJ/NOPB	ACTIVE	DDPAK/ TO-263	KTW	7	500	RoHS-Exempt & Green	SN	Level-3-245C-168 HR	-40 to 125	LM2588S -ADJ P+	Samples
LM2588T-3.3/NOPB	ACTIVE	TO-220	NDZ	7	45	RoHS-Exempt & Green	SN	Level-1-NA-UNLIM	-40 to 125	LM2588T -3.3 P+	Samples
LM2588T-5.0/NOPB	ACTIVE	TO-220	NDZ	7	45	RoHS-Exempt & Green	SN	Level-1-NA-UNLIM	-40 to 125	LM2588T -5.0 P+	Samples
LM2588T-ADJ/NOPB	ACTIVE	TO-220	NDZ	7	45	RoHS-Exempt & Green	SN	Level-1-NA-UNLIM	-40 to 125	LM2588T -ADJ P+	Samples

(1) The marketing status values are defined as follows:

ACTIVE: Product device recommended for new designs.

LIFEBUY: TI has announced that the device will be discontinued, and a lifetime-buy period is in effect.

NRND: Not recommended for new designs. Device is in production to support existing customers, but TI does not recommend using this part in a new design.

PREVIEW: Device has been announced but is not in production. Samples may or may not be available.

OBSELETE: TI has discontinued the production of the device.

(2) **RoHS:** TI defines "RoHS" to mean semiconductor products that are compliant with the current EU RoHS requirements for all 10 RoHS substances, including the requirement that RoHS substance do not exceed 0.1% by weight in homogeneous materials. Where designed to be soldered at high temperatures, "RoHS" products are suitable for use in specified lead-free processes. TI may reference these types of products as "Pb-Free".

RoHS Exempt: TI defines "RoHS Exempt" to mean products that contain lead but are compliant with EU RoHS pursuant to a specific EU RoHS exemption.

Green: TI defines "Green" to mean the content of Chlorine (Cl) and Bromine (Br) based flame retardants meet JS709B low halogen requirements of ≤ 1000 ppm threshold. Antimony trioxide based flame retardants must also meet the ≤ 1000 ppm threshold requirement.

(3) MSL, Peak Temp. - The Moisture Sensitivity Level rating according to the JEDEC industry standard classifications, and peak solder temperature.

(4) There may be additional marking, which relates to the logo, the lot trace code information, or the environmental category on the device.

(5) Multiple Device Markings will be inside parentheses. Only one Device Marking contained in parentheses and separated by a "~" will appear on a device. If a line is indented then it is a continuation of the previous line and the two combined represent the entire Device Marking for that device.

(6) Lead finish/Ball material - Orderable Devices may have multiple material finish options. Finish options are separated by a vertical ruled line. Lead finish/Ball material values may wrap to two lines if the finish value exceeds the maximum column width.

Important Information and Disclaimer: The information provided on this page represents TI's knowledge and belief as of the date that it is provided. TI bases its knowledge and belief on information provided by third parties, and makes no representation or warranty as to the accuracy of such information. Efforts are underway to better integrate information from third parties. TI has taken and continues to take reasonable steps to provide representative and accurate information but may not have conducted destructive testing or chemical analysis on incoming materials and chemicals. TI and TI suppliers consider certain information to be proprietary, and thus CAS numbers and other limited information may not be available for release.

In no event shall TI's liability arising out of such information exceed the total purchase price of the TI part(s) at issue in this document sold by TI to Customer on an annual basis.

TAPE AND REEL INFORMATION

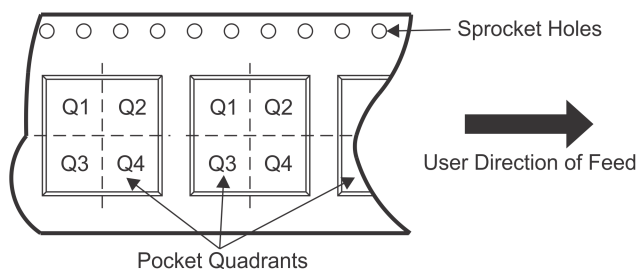
QUADRANT ASSIGNMENTS FOR PIN 1 ORIENTATION IN TAPE

*All dimensions are nominal

Device	Package Type	Package Drawing	Pins	SPQ	Reel Diameter (mm)	Reel Width W1 (mm)	A0 (mm)	B0 (mm)	K0 (mm)	P1 (mm)	W (mm)	Pin1 Quadrant
LM2588SX-12/NOPB	DDPAK/ TO-263	KTW	7	500	330.0	24.4	10.75	14.85	5.0	16.0	24.0	Q2
LM2588SX-3.3/NOPB	DDPAK/ TO-263	KTW	7	500	330.0	24.4	10.75	14.85	5.0	16.0	24.0	Q2
LM2588SX-5.0/NOPB	DDPAK/ TO-263	KTW	7	500	330.0	24.4	10.75	14.85	5.0	16.0	24.0	Q2
LM2588SX-ADJ/NOPB	DDPAK/ TO-263	KTW	7	500	330.0	24.4	10.75	14.85	5.0	16.0	24.0	Q2

TAPE AND REEL BOX DIMENSIONS

*All dimensions are nominal

Device	Package Type	Package Drawing	Pins	SPQ	Length (mm)	Width (mm)	Height (mm)
LM2588SX-12/NOPB	DDPAK/TO-263	KTW	7	500	367.0	367.0	45.0
LM2588SX-3.3/NOPB	DDPAK/TO-263	KTW	7	500	367.0	367.0	45.0
LM2588SX-5.0/NOPB	DDPAK/TO-263	KTW	7	500	367.0	367.0	45.0
LM2588SX-ADJ/NOPB	DDPAK/TO-263	KTW	7	500	367.0	367.0	45.0

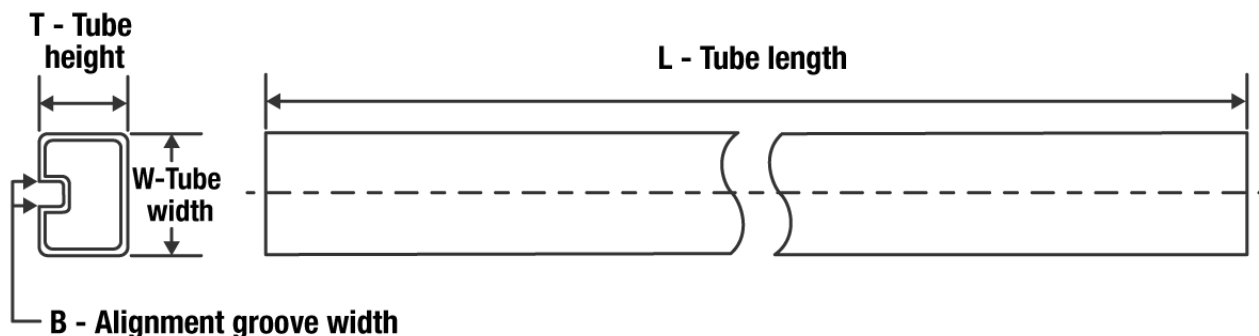
TUBE

*All dimensions are nominal

Device	Package Name	Package Type	Pins	SPQ	L (mm)	W (mm)	T (μm)	B (mm)
LM2588S-12/NOPB	KTW	TO-263	7	45	502	25	8204.2	9.19
LM2588S-3.3/NOPB	KTW	TO-263	7	45	502	25	8204.2	9.19
LM2588S-5.0/NOPB	KTW	TO-263	7	45	502	25	8204.2	9.19
LM2588S-ADJ	KTW	TO-263	7	45	502	25	8204.2	9.19
LM2588S-ADJ	KTW	TO-263	7	45	502	25	8204.2	9.19
LM2588S-ADJ/NOPB	KTW	TO-263	7	45	502	25	8204.2	9.19
LM2588T-3.3/NOPB	NDZ	TO-220	7	45	502	30	30048.2	10.74
LM2588T-5.0/NOPB	NDZ	TO-220	7	45	502	30	30048.2	10.74
LM2588T-ADJ/NOPB	NDZ	TO-220	7	45	502	30	30048.2	10.74

NDZ0007B

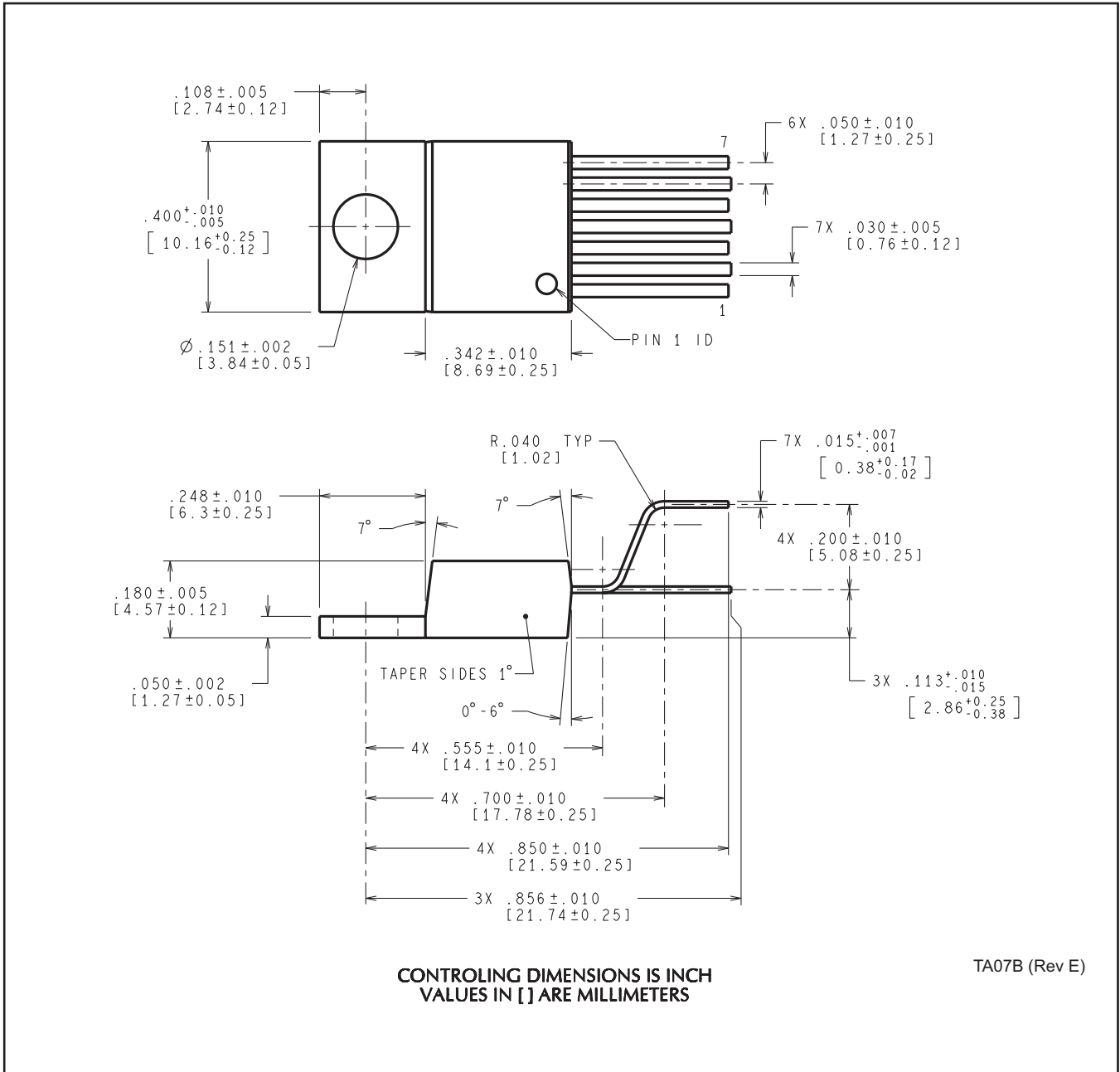

重要声明和免责声明

TI“按原样”提供技术和可靠性数据（包括数据表）、设计资源（包括参考设计）、应用或其他设计建议、网络工具、安全信息和其他资源，不保证没有瑕疵且不做任何明示或暗示的担保，包括但不限于对适销性、某特定用途方面的适用性或不侵犯任何第三方知识产权的暗示担保。

这些资源可供使用 TI 产品进行设计的熟练开发人员使用。您将自行承担以下全部责任：(1) 针对您的应用选择合适的 TI 产品，(2) 设计、验证并测试您的应用，(3) 确保您的应用满足相应标准以及任何其他功能安全、信息安全、监管或其他要求。

这些资源如有变更，恕不另行通知。TI 授权您仅可将这些资源用于研发本资源所述的 TI 产品的应用。严禁对这些资源进行其他复制或展示。您无权使用任何其他 TI 知识产权或任何第三方知识产权。您应全额赔偿因在这些资源的使用中对 TI 及其代表造成的任何索赔、损害、成本、损失和债务，TI 对此概不负责。

TI 提供的产品受 [TI 的销售条款](#) 或 [ti.com](#) 上其他适用条款/TI 产品随附的其他适用条款的约束。TI 提供这些资源并不会扩展或以其他方式更改 TI 针对 TI 产品发布的适用的担保或担保免责声明。

TI 反对并拒绝您可能提出的任何其他或不同的条款。

邮寄地址：Texas Instruments, Post Office Box 655303, Dallas, Texas 75265

Copyright © 2022，德州仪器 (TI) 公司