

LMx58-N 低功耗双路运算放大器

1 特性

- 采用 8 凸点 DSBGA 芯片尺寸封装 (参阅 AN-1112, [SNVA009](#))
- 采用内部频率补偿方式实现单位增益
- 大直流电压增益: 100dB
- 宽带宽 (单位增益): 1 MHz (温度补偿)
- 宽电源电压范围:
 - 单电源: 3 V 至 32 V
 - 或双电源: ± 1.5 V 至 ± 16 V
- 本质上独立于电源电压的超低电源电流消耗 (500 μ A)
- 低输入失调电压: 2 mV
- 输入共模电压范围包括接地
- 差分输入电压范围等于电源电压
- 大输出电压摆幅
- 独特的特性:
 - 在线性模式下, 即使由单电源电压供电, 输入共模电压范围也包括接地, 输出电压还能够摆动至地
 - 单位增益交叉频率具有温度补偿特性
 - 输入偏置电流也具有温度补偿特性
- 优势:
 - 两个内部补偿运算放大器
 - 消除了对双电源的需求
 - 允许靠近 GND 直接感测, V_{OUT} 也接入 GND
 - 与所有形式的逻辑兼容
 - 具有适用于电池供电的功耗

2 应用

- 有源滤波器
- 通用信号调节和放大
- 4 mA 至 20 mA 电流环路变送器

3 说明

LM158 系列包含两个独立的高增益内部频率补偿运算放大器, 专门适用于在宽电压范围内采用单电源供电运行方式。也可以由分离式电源供电, 并且低电源电流消耗与电源电压的大小无关。

应用领域包括传感器放大器、直流增益块和所有传统运算放大器电路, 现在, 这些均可在单电源系统中轻松实施。例如, LM158 系列可以直接在数字系统中使用的标准 3.3 V 电源电压下操作, 并可轻松提供所需的接口电子元件, 而无需附加的 ± 15 V 电源。

LM358 和 LM2904 采用使用 TI DSBGA 封装技术的芯片尺寸封装 (8 凸点 DSBGA 封装)。

器件信息

器件型号 ⁽¹⁾	封装	封装尺寸 (标称值)
LM158-N	TO-CAN (8)	9.08 mm \times 9.09 mm
	CDIP (8)	10.16 mm \times 6.502 mm
LM258-N	TO-CAN (8)	9.08 mm \times 9.09 mm
	DSBGA (8)	1.31 mm \times 1.31 mm
LM2904-N	SOIC (8)	4.90mm \times 3.91mm
	PDIP (8)	9.81mm \times 6.35mm
	TO-CAN (8)	9.08 mm \times 9.09 mm
LM358-N	DSBGA (8)	1.31 mm \times 1.31 mm
	SOIC (8)	4.90mm \times 3.91mm
	PDIP (8)	9.81mm \times 6.35mm
	TO-CAN (8)	9.08 mm \times 9.09 mm

(1) 如需了解所有可用封装, 请参阅产品说明书末尾的可订购产品附录。

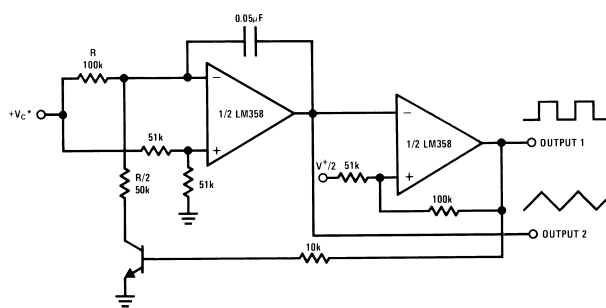

压控振荡器 (VCO)



Table of Contents

1 特性.....	1	7.3 Feature Description.....	12
2 应用.....	1	7.4 Device Functional Modes.....	13
3 说明.....	1	8 Application and Implementation.....	14
4 Revision History.....	2	8.1 Application Information.....	14
5 Pin Configuration and Functions.....	3	8.2 Typical Applications.....	14
6 Specifications.....	4	9 Power Supply Recommendations.....	22
6.1 Absolute Maximum Ratings.....	4	10 Layout.....	22
6.2 ESD Ratings.....	4	10.1 Layout Guidelines.....	22
6.3 Recommended Operating Conditions.....	5	10.2 Layout Example.....	22
6.4 Thermal Information.....	5	11 Device and Documentation Support.....	23
6.5 Electrical Characteristics: LM158A, LM358A, LM158, LM258.....	5	11.1 接收文档更新通知.....	23
6.6 Electrical Characteristics: LM358, LM2904.....	7	11.2 支持资源.....	23
6.7 Typical Characteristics.....	9	11.3 Trademarks.....	23
7 Detailed Description.....	12	11.4 Electrostatic Discharge Caution.....	23
7.1 Overview.....	12	11.5 术语表.....	23
7.2 Functional Block Diagram.....	12	12 Mechanical, Packaging, and Orderable Information.....	23

4 Revision History

注：以前版本的页码可能与当前版本的页码不同

Changes from Revision I (December 2014) to Revision J (March 2022)	Page
• 更新了整个文档中的表格、图和交叉参考的编号格式.....	1
• Corrected pin 5 (+INB) and pin 7 (OUTB) description information in the <i>Pin Configuration and Functions</i> section.....	3
• Deleted <i>Related Links</i> from the <i>Device and Documentation Support</i> section.....	23

Changes from Revision H (March 2013) to Revision I (December 2014)	Page
• 新增了引脚配置和功能部分、ESD 等级表、特性说明部分、器件功能模式、应用和实施部分、电源相关建议部分、布局部分、器件和文档支持部分以及机械、封装和可订购信息部分.....	1

Changes from Revision G (March 2013) to Revision H (March 2013)	Page
• 已将国家数据表的版面布局更改为 TI 格式.....	1

5 Pin Configuration and Functions



图 5-1. D, P, and NAB Package 8-Pin SOIC, PDIP, and CDIP (Top View)



图 5-2. LMC Package 8-Pin TO-99 Top View

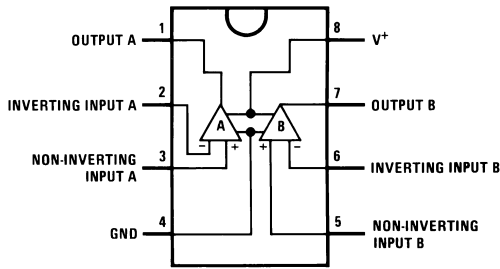

图 5-3. YPB Package 8-Pin DSBGA Top View

表 5-1. Pin Functions

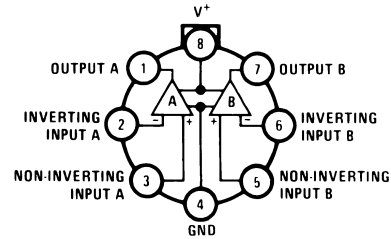
PIN			TYPE ⁽¹⁾	DESCRIPTION
NAME	D/P/LMC	YPB		
OUTA	1	A1	O	Output, channel A
- INA	2	B1	I	Inverting input, channel A
+INA	3	C1	I	Non-inverting input, channel A
GND / V ₋	4	C2	P	Ground for single-supply configurations. Negative supply for dual-supply configurations.
+INB	5	C3	I	Non-inverting input, channel B
- INB	6	B3	I	Inverting input, channel B
OUTB	7	A3	O	Output, channel B
V ₊	8	A2	P	Positive supply

(1) Signal Types: I = Input, O = Output, I/O = Input or Output, P = Power

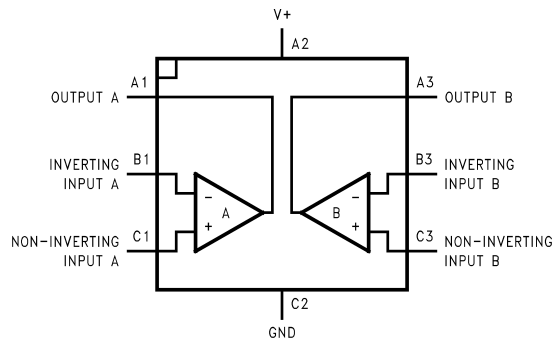
6 Specifications

6.1 Absolute Maximum Ratings

See (1) (2) (3).

		LM158, LM258, LM358, LM158A, LM258A, LM358A		LM2904		UNIT		
		MIN	MAX	MIN	MAX			
Supply Voltage, V^+		32		26		V		
Differential Input Voltage		32		26		V		
Input Voltage		-0.3	32	-0.3	26	V		
Power Dissipation ⁽⁴⁾	PDIP (P)	830		830		mW		
	TO-99 (LMC)	550				mW		
	SOIC (D)	530		530		mW		
	DSBGA (YPB)	435				mW		
Output Short-Circuit to GND (One Amplifier) ⁽⁵⁾	$V^+ \leq 15\text{ V}$ and $T_A = 25^\circ\text{C}$		Continuous		Continuous			
Input Current ($V_{IN} < -0.3\text{V}$) ⁽⁶⁾		50		50		mA		
Temperature			-55	125			$^\circ\text{C}$	
	PDIP Package (P): Soldering (10 seconds)		260		260		$^\circ\text{C}$	
	SOIC Package (D)	Vapor Phase (60 seconds)		215		215		$^\circ\text{C}$
		Infrared (15 seconds)		220		220		$^\circ\text{C}$
Lead Temperature	PDIP (P): (Soldering, 10 seconds)		260		260		$^\circ\text{C}$	
	TO-99 (LMC): (Soldering, 10 seconds)		300		300		$^\circ\text{C}$	
Storage temperature, T_{stg}		-65	150	-65	150	$^\circ\text{C}$		

- (1) *Absolute Maximum Ratings* indicate limits beyond which damage to the device may occur. *Recommended Operating Conditions* indicate conditions for which the device is intended to be functional, but specific performance is not ensured. For ensured specifications and the test conditions, see the Electrical Characteristics.
- (2) Refer to RETS158AX for LM158A military specifications and to RETS158X for LM158 military specifications.
- (3) If Military/Aerospace specified devices are required, please contact the TI Sales Office/Distributors for availability and specifications.
- (4) For operating at high temperatures, the LM358/LM358A, LM2904 must be derated based on a 125°C maximum junction temperature and a thermal resistance of 120°C/W for PDIP, 182°C/W for TO-99, 189°C/W for SOIC package, and 230°C/W for DSBGA, which applies for the device soldered in a printed circuit board, operating in a still air ambient. The LM258/LM258A and LM158/LM158A can be derated based on a $+150^\circ\text{C}$ maximum junction temperature. The dissipation is the total of both amplifiers—use external resistors, where possible, to allow the amplifier to saturate or to reduce the power which is dissipated in the integrated circuit.
- (5) Short circuits from the output to V^+ can cause excessive heating and eventual destruction. When considering short circuits to ground, the maximum output current is approximately 40 mA independent of the magnitude of V^+ . At values of supply voltage in excess of +15 V, continuous short-circuits can exceed the power dissipation ratings and cause eventual destruction. Destructive dissipation can result from simultaneous shorts on all amplifiers.
- (6) This input current will only exist when the voltage at any of the input leads is driven negative. It is due to the collector-base junction of the input PNP transistors becoming forward biased and thereby acting as input diode clamps. In addition to this diode action, there is also lateral NPN parasitic transistor action on the IC chip. This transistor action can cause the output voltages of the op amps to go to the V^+ voltage level (or to ground for a large overdrive) for the time duration that an input is driven negative. This is not destructive and normal output states will re-establish when the input voltage, which was negative, again returns to a value greater than -0.3 V (at 25°C).

6.2 ESD Ratings

			VALUE	UNIT
$V_{(ESD)}$	Electrostatic discharge	Human-body model (HBM), per ANSI/ESDA/JEDEC JS-001 ⁽¹⁾	± 250	V

- (1) JEDEC document JEP155 states that 500-V HBM allows safe manufacturing with a standard ESD control process.

6.3 Recommended Operating Conditions

over operating free-air temperature range (unless otherwise noted)

	MIN	MAX	UNIT
Supply Voltage (V+ - V-):LM158, LM258, LM358	3 (±1.5)	32 (±16)	V
Supply Voltage (V+ - V-):LM2904	3 (±1.5)	26 (±13)	V
Operating Temperature: LM158	-55	125	°C
Operating Temperature: LM258	-25	85	°C
Operating Temperature: LM358	0	70	°C
Operating Temperature: LM2904	-40	85	°C

6.4 Thermal Information

THERMAL METRIC ⁽¹⁾	LM158-N, LM258-N, LM358-N	LM158-N	LM2904-N, LM358-N			UNIT
	LMC	NAB	YPB	D	P	
	8 PINS					
R _{θJA} Junction-to-ambient thermal resistance	155	132	230	189	120	°C/W

(1) For more information about traditional and new thermal metrics, see the *IC Package Thermal Metrics* application report, [SPRA953](#).

6.5 Electrical Characteristics: LM158A, LM358A, LM158, LM258

V⁺ = +5.0 V, See⁽²⁾, unless otherwise stated

PARAMETER	TEST CONDITIONS	LM158A			LM358A			LM158, LM258			UNIT
		MIN	TYP	MAX	MIN	TYP	MAX	MIN	TYP	MAX	
Input Offset Voltage	See ⁽³⁾ , T _A = 25°C	1	2	2	3	2	5	mV			
Input Bias Current	I _{IN(+)} or I _{IN(-)} , T _A = 25°C, V _{CM} = 0 V, ⁽⁴⁾	20	50	45	100	45	150	nA			
Input Offset Current	I _{IN(+)} - I _{IN(-)} , V _{CM} = 0V, T _A = 25°C	2	10	5	30	3	30	nA			
Input Common-Mode	V ⁺ = 30 V, ⁽⁵⁾	0	V ⁺ -1.5	0	V ⁺ -1.5	0	V ⁺ -1.5	V			
Voltage Range	(LM2904, V ⁺ = 26V), T _A = 25°C	0	V ⁺ -1.5	0	V ⁺ -1.5	0	V ⁺ -1.5	V			
Supply Current	Over Full Temperature Range R _L = ∞ on All Op Amps V ⁺ = 30V (LM2904 V ⁺ = 26V) V ⁺ = 5V	1	2	1	2	1	2	mA			
Large Signal Voltage Gain	V ⁺ = 15 V, T _A = 25°C, R _L ≥ 2 kΩ, (For V _O = 1 V to 11 V)	50	100	25	100	50	100	V/mV			
Common-Mode	T _A = 25°C,	70	85	65	85	70	85	dB			
Rejection Ratio	V _{CM} = 0 V to V ⁺ -1.5 V	65	100	65	100	65	100				
Power Supply	V ⁺ = 5 V to 30 V	65	100	65	100	65	100	dB			
Rejection Ratio	(LM2904, V ⁺ = 5 V to 26 V), T _A = 25°C	65	100	65	100	65	100				
Power Supply	V ⁺ = 5 V to 30 V	65	100	65	100	65	100	dB			
Rejection Ratio	(LM2904, V ⁺ = 5 V to 26 V), T _A = 25°C	65	100	65	100	65	100				
Amplifier-to-Amplifier Coupling	f = 1 kHz to 20 kHz, T _A = 25°C (Input Referred), See ⁽⁶⁾	-120		-120		-120		dB			

6.5 Electrical Characteristics: LM158A, LM358A, LM158, LM258 (continued)

$V^+ = +5.0\text{ V}$, See⁽²⁾, unless otherwise stated

PARAMETER		TEST CONDITIONS	LM158A			LM358A			LM158, LM258			UNIT
			MIN	TYP	MAX	MIN	TYP	MAX	MIN	TYP	MAX	
Output Current	Source	$V_{IN}^+ = 1\text{ V}$,	20	40	20	40	20	40	20	40	mA	
		$V_{IN}^- = 0\text{ V}$,										
		$V^+ = 15\text{ V}$,										
	$V_O = 2\text{ V}$, $T_A = 25^\circ\text{C}$											
	Sink	$V_{IN}^- = 1\text{ V}$, $V_{IN}^+ = 0\text{ V}$	10	20	10	20	10	20	10	20		mA
		$V^+ = 15\text{ V}$, $T_A = 25^\circ\text{C}$,										
$V_O = 2\text{ V}$												
		$V_{IN}^- = 1\text{ V}$,	12	50	12	50	12	50	12	50	$\mu\text{ A}$	
		$V_{IN}^+ = 0\text{ V}$										
		$T_A = 25^\circ\text{C}$, $V_O = 200\text{ mV}$,										
		$V^+ = 15\text{ V}$										
Short Circuit to Ground		$T_A = 25^\circ\text{C}$, See ⁽¹⁾ , $V^+ = 15\text{ V}$		40	60	40	60	40	60	mA		
Input Offset Voltage		See ⁽³⁾		4		5		7		mV		
Input Offset Voltage Drift		$R_S = 0\ \Omega$		7	15	7	20	7		$\mu\text{ V}/^\circ\text{C}$		
Input Offset Current		$I_{IN(+)} - I_{IN(-)}$		30		75		100		nA		
Input Offset Current Drift		$R_S = 0\ \Omega$		10	200	10	300	10		$\text{pA}/^\circ\text{C}$		
Input Bias Current		$I_{IN(+)}$ or $I_{IN(-)}$		40	100	40	200	40	300	nA		
Input Common-Mode Voltage Range		$V^+ = 30\text{ V}$, See ⁽⁵⁾ (LM2904, $V^+ = 26\text{ V}$)		0	$V^+ - 2$	0	$V^+ - 2$	0	$V^+ - 2$	V		
Large Signal Voltage Gain	$V^+ = +15\text{ V}$		25		15		25				V/mV	
	$(V_O = 1\text{ V to } 11\text{ V})$											
	$R_L \geq 2\text{ k}\ \Omega$											
Output	V_{OH}	$V^+ = +30\text{ V}$	26		26		26				V	
Voltage		(LM2904, $V^+ = 26\text{ V}$)										$R_L = 10\text{ k}\ \Omega$
Swing	V_{OL}	$V^+ = 5\text{ V}$, $R_L = 10\text{ k}\ \Omega$		5	20	5	20	5	20	mV		
Output Current	Source	$V_{IN}^+ = +1\text{ V}$, $V_{IN}^- = 0\text{ V}$,	10	20	10	20	10	20	10	20	mA	
		$V^+ = 15\text{ V}$, $V_O = 2\text{ V}$										
	Sink	$V_{IN}^- = +1\text{ V}$, $V_{IN}^+ = 0\text{ V}$,	10	15	5	8	5	8	5	8		
		$V^+ = 15\text{ V}$, $V_O = 2\text{ V}$										

- Short circuits from the output to V^+ can cause excessive heating and eventual destruction. When considering short circuits to ground, the maximum output current is approximately 40 mA independent of the magnitude of V^+ . At values of supply voltage in excess of +15 V, continuous short-circuits can exceed the power dissipation ratings and cause eventual destruction. Destructive dissipation can result from simultaneous shorts on all amplifiers.
- These specifications are limited to $-55^\circ\text{C} \leq T_A \leq +125^\circ\text{C}$ for the LM158/LM158A. With the LM258/LM258A, all temperature specifications are limited to $-25^\circ\text{C} \leq T_A \leq 85^\circ\text{C}$, the LM358/LM358A temperature specifications are limited to $0^\circ\text{C} \leq T_A \leq 70^\circ\text{C}$, and the LM2904 specifications are limited to $-40^\circ\text{C} \leq T_A \leq 85^\circ\text{C}$.
- $V_O \approx 1.4\text{ V}$, $R_S = 0\ \Omega$ with V^+ from 5 V to 30 V; and over the full input common-mode range (0 V to $V^+ - 1.5\text{ V}$) at 25°C . For LM2904, V^+ from 5 V to 26 V.
- The direction of the input current is out of the IC due to the PNP input stage. This current is essentially constant, independent of the state of the output so no loading change exists on the input lines.
- The input common-mode voltage of either input signal voltage should not be allowed to go negative by more than 0.3 V (at 25°C). The upper end of the common-mode voltage range is $V^+ - 1.5\text{ V}$ (at 25°C), but either or both inputs can go to 32 V without damage (26 V for LM2904), independent of the magnitude of V^+ .
- Due to proximity of external components, insure that coupling is not originating via stray capacitance between these external parts. This typically can be detected as this type of capacitance increases at higher frequencies.

6.6 Electrical Characteristics: LM358, LM2904

$V^+ = +5.0\text{ V}$, See⁽²⁾, unless otherwise stated

PARAMETER		TEST CONDITIONS	LM358			LM2904			UNIT	
			MIN	TYP	MAX	MIN	TYP	MAX		
Input Offset Voltage		See ⁽³⁾ , $T_A = 25^\circ\text{C}$		2	7		2	7	mV	
Input Bias Current		$I_{IN(+)}$ or $I_{IN(-)}$, $T_A = 25^\circ\text{C}$, $V_{CM} = 0\text{ V}$, See ⁽⁴⁾		45	250		45	250	nA	
Input Offset Current		$I_{IN(+)} - I_{IN(-)}$, $V_{CM} = 0\text{ V}$, $T_A = 25^\circ\text{C}$		5	50		5	50	nA	
Input Common-Mode Voltage Range		$V^+ = 30\text{ V}$, See ⁽⁵⁾ (LM2904, $V^+ = 26\text{ V}$), $T_A = 25^\circ\text{C}$	0		$V^+ - 1.5$	0		$V^+ - 1.5$	V	
Supply Current		Over Full Temperature Range								
		$R_L = \infty$ on All Op Amps								
		$V^+ = 30\text{ V}$ (LM2904 $V^+ = 26\text{ V}$)		1	2		1	2	mA	
		$V^+ = 5\text{ V}$		0.5	1.2		0.5	1.2	mA	
Large Signal Voltage		$V^+ = 15\text{ V}$, $T_A = 25^\circ\text{C}$,								
Gain		$R_L \geq 2\text{ k}\Omega$, (For $V_O = 1\text{ V}$ to 11 V)	25	100		25	100		V/mV	
Common-Mode Rejection Ratio		$T_A = 25^\circ\text{C}$,	65	85		50	70		dB	
		$V_{CM} = 0\text{ V}$ to $V^+ - 1.5\text{ V}$								
Power Supply Rejection Ratio		$V^+ = 5\text{ V}$ to 30 V	65	100		50	100		dB	
		(LM2904, $V^+ = 5\text{ V}$ to 26 V), $T_A = 25^\circ\text{C}$								
Amplifier-to-Amplifier Coupling		$f = 1\text{ kHz}$ to 20 kHz , $T_A = 25^\circ\text{C}$ (Input Referred), See ⁽⁶⁾		-120			-120		dB	
Output Current	Source	$V_{IN}^+ = 1\text{ V}$,	20	40		20	40		mA	
		$V_{IN}^- = 0\text{ V}$,								
		$V^+ = 15\text{ V}$,								
		$V_O = 2\text{ V}$, $T_A = 25^\circ\text{C}$								
	Sink	$V_{IN}^- = 1\text{ V}$, $V_{IN}^+ = 0\text{ V}$	10	20		10	20		mA	
		$V^+ = 15\text{ V}$, $T_A = 25^\circ\text{C}$,								
		$V_O = 2\text{ V}$								
		$V_{IN}^- = 1\text{ V}$,								
	12	50		12	50		μA			
$V_{IN}^+ = 0\text{ V}$										
$T_A = 25^\circ\text{C}$, $V_O = 200\text{ mV}$,										
Short Circuit to Ground		$T_A = 25^\circ\text{C}$, See ⁽¹⁾ , $V^+ = 15\text{ V}$		40	60		40	60	mA	
Input Offset Voltage		See ⁽³⁾			9			10	mV	
Input Offset Voltage Drift		$R_S = 0\ \Omega$		7			7		$\mu\text{ V}/^\circ\text{C}$	
Input Offset Current		$I_{IN(+)} - I_{IN(-)}$			150		45	200	nA	
Input Offset Current Drift		$R_S = 0\ \Omega$		10			10		$\text{pA}/^\circ\text{C}$	
Input Bias Current		$I_{IN(+)}$ or $I_{IN(-)}$		40	500		40	500	nA	
Input Common-Mode Voltage Range		$V^+ = 30\text{ V}$, See ⁽⁵⁾ (LM2904, $V^+ = 26\text{ V}$)	0		$V^+ - 2$	0		$V^+ - 2$	V	
Large Signal Voltage Gain		$V^+ = +15\text{ V}$	15			15			V/mV	
		($V_O = 1\text{ V}$ to 11 V)								
		$R_L \geq 2\text{ k}\Omega$								
Output	V_{OH}	$V^+ = 30\text{ V}$					22		V	
Voltage		(LM2904, $V^+ = 26\text{ V}$)		$R_L = 2\text{ k}\Omega$	26					
					27	28		23	24	V
Swing	V_{OL}	$V^+ = 5\text{ V}$, $R_L = 10\text{ k}\Omega$		5	20		5	100	mV	

6.6 Electrical Characteristics: LM358, LM2904 (continued)

$V^+ = +5.0\text{ V}$, See⁽²⁾, unless otherwise stated

PARAMETER		TEST CONDITIONS	LM358			LM2904			UNIT
			MIN	TYP	MAX	MIN	TYP	MAX	
Output Current	Source	$V_{IN}^+ = 1\text{ V}, V_{IN}^- = 0\text{ V},$	10	20		10	20	mA	
		$V^+ = 15\text{ V}, V_O = 2\text{ V}$							
	Sink	$V_{IN}^- = 1\text{ V}, V_{IN}^+ = 0\text{ V},$	5	8		5	8		
		$V^+ = 15\text{ V}, V_O = 2\text{ V}$							

- Short circuits from the output to V^+ can cause excessive heating and eventual destruction. When considering short circuits to ground, the maximum output current is approximately 40 mA independent of the magnitude of V^+ . At values of supply voltage in excess of +15 V, continuous short-circuits can exceed the power dissipation ratings and cause eventual destruction. Destructive dissipation can result from simultaneous shorts on all amplifiers.
- These specifications are limited to $-55^\circ\text{C} \leq T_A \leq +125^\circ\text{C}$ for the LM158/LM158A. With the LM258/LM258A, all temperature specifications are limited to $-25^\circ\text{C} \leq T_A \leq 85^\circ\text{C}$, the LM358/LM358A temperature specifications are limited to $0^\circ\text{C} \leq T_A \leq 70^\circ\text{C}$, and the LM2904 specifications are limited to $-40^\circ\text{C} \leq T_A \leq 85^\circ\text{C}$.
- $V_O \approx 1.4\text{ V}$, $R_S = 0\ \Omega$ with V^+ from 5 V to 30 V; and over the full input common-mode range (0 V to $V^+ - 1.5\text{ V}$) at 25°C . For LM2904, V^+ from 5 V to 26 V.
- The direction of the input current is out of the IC due to the PNP input stage. This current is essentially constant, independent of the state of the output so no loading change exists on the input lines.
- The input common-mode voltage of either input signal voltage should not be allowed to go negative by more than 0.3 V (at 25°C). The upper end of the common-mode voltage range is $V^+ - 1.5\text{ V}$ (at 25°C), but either or both inputs can go to 32 V without damage (26 V for LM2904), independent of the magnitude of V^+ .
- Due to proximity of external components, insure that coupling is not originating via stray capacitance between these external parts. This typically can be detected as this type of capacitance increases at higher frequencies.

6.7 Typical Characteristics

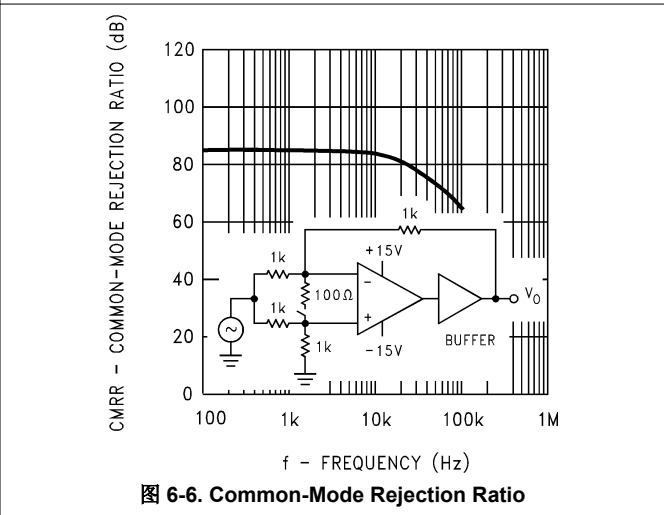
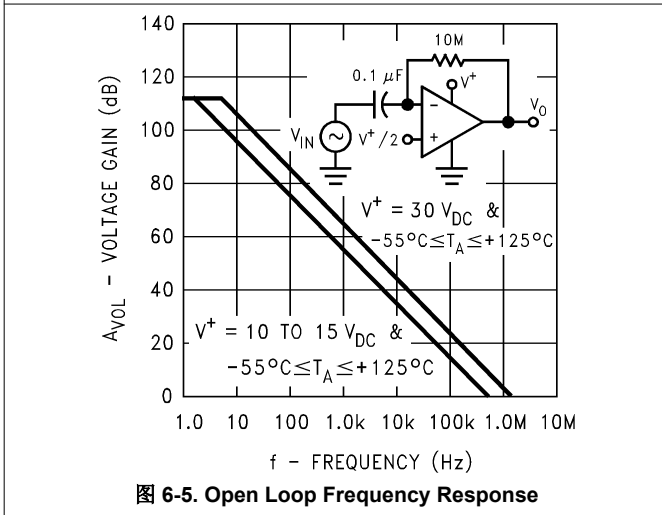
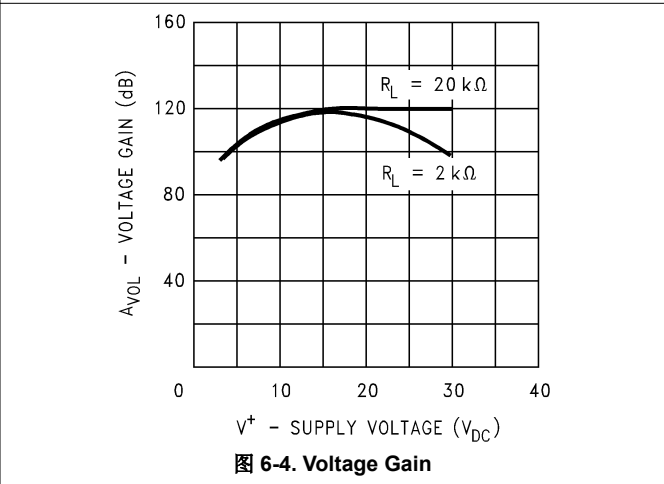
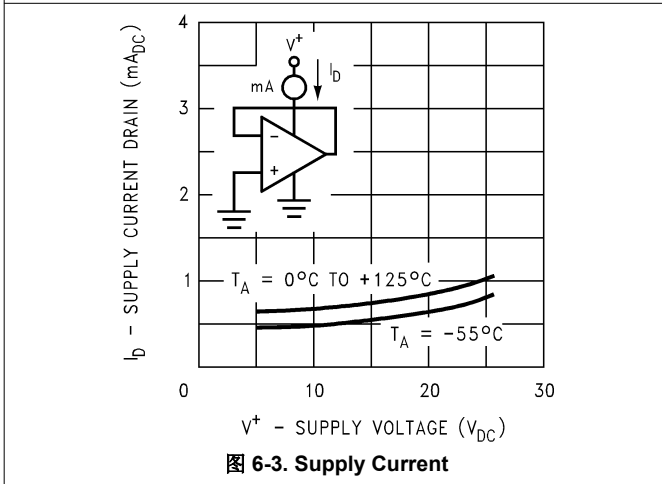
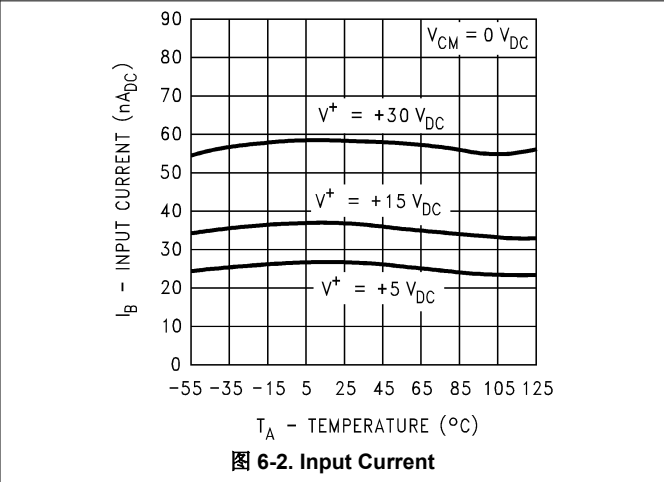
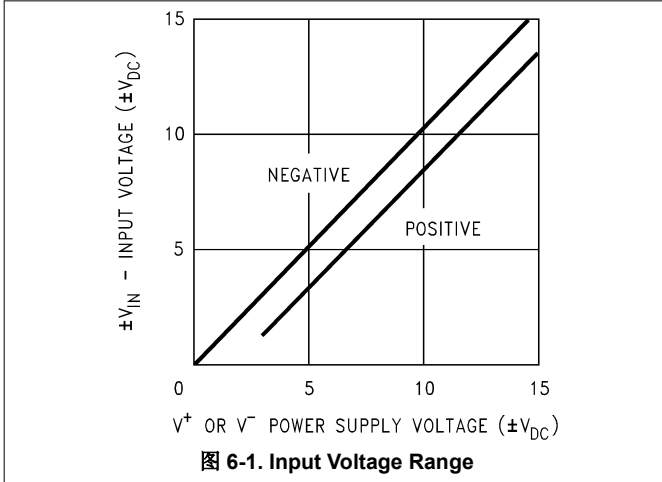

6.7 Typical Characteristics (continued)



图 6-7. Voltage Follower Pulse Response



图 6-8. Voltage Follower Pulse Response (Small Signal)

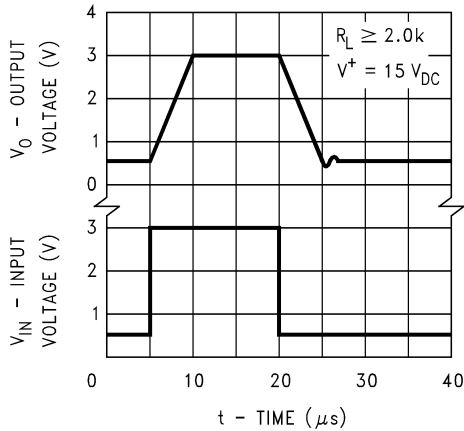

图 6-9. Large Signal Frequency Response

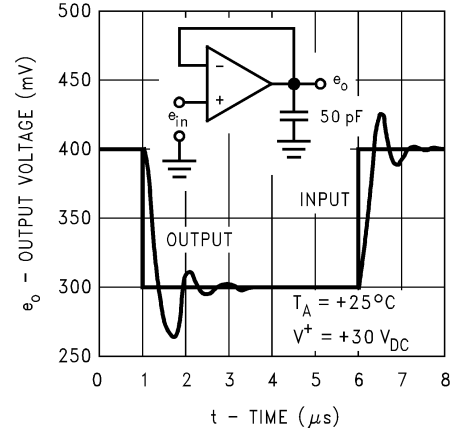

图 6-10. Output Characteristics Current Sourcing

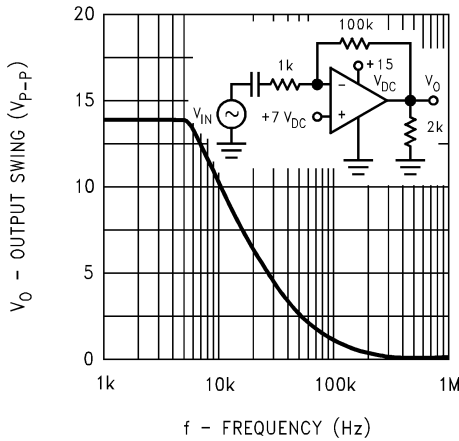

图 6-11. Output Characteristics Current Sinking

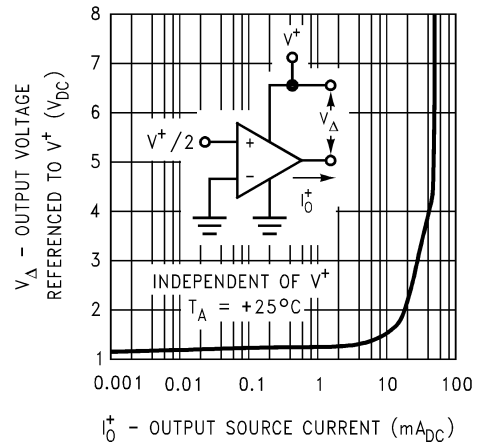

图 6-12. Current Limiting

6.7 Typical Characteristics (continued)

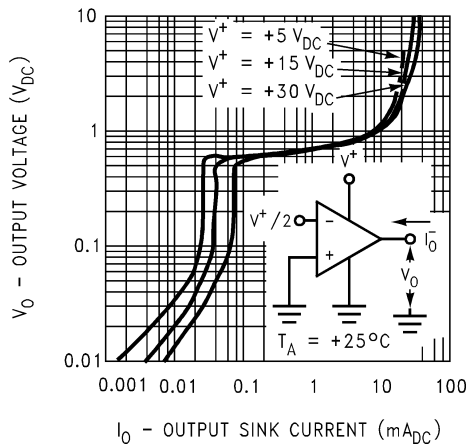

图 6-13. Input Current (LM2902 Only)

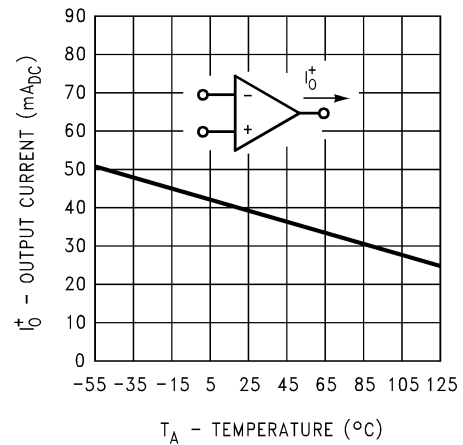

图 6-14. Voltage Gain (LM2902 Only)

7 Detailed Description

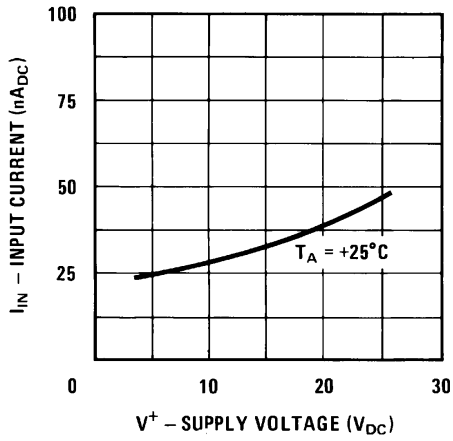
7.1 Overview

The LM158 series are operational amplifiers which can operate with only a single power supply voltage, have true-differential inputs, and remain in the linear mode with an input common-mode voltage of $0 V_{DC}$. These amplifiers operate over a wide range of power supply voltage with little change in performance characteristics. At 25°C amplifier operation is possible down to a minimum supply voltage of $2.3 V_{DC}$.

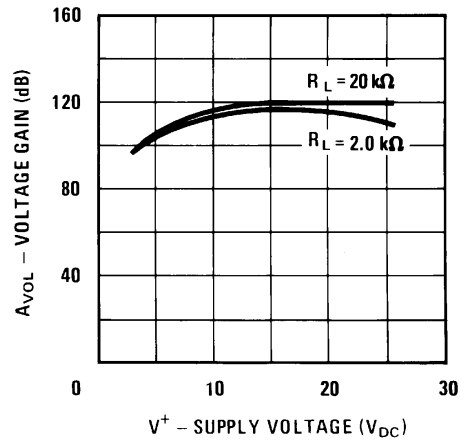
Large differential input voltages can be easily accommodated and, as input differential voltage protection diodes are not needed, no large input currents result from large differential input voltages. The differential input voltage may be larger than V^+ without damaging the device. Protection should be provided to prevent the input voltages from going negative more than $-0.3 V_{DC}$ (at 25°C). An input clamp diode with a resistor to the IC input terminal can be used.

7.2 Functional Block Diagram



图 7-1. (Each Amplifier)

7.3 Feature Description

The amplifier's differential inputs consist of a non-inverting input (+IN) and an inverting input (-IN). The amplifier amplifies only the difference in voltage between the two inputs, which is called the differential input voltage. The output voltage of the op-amp V_{out} is given by Equation 1:

$$V_{OUT} = A_{OL} (IN+ - IN-) \quad (1)$$

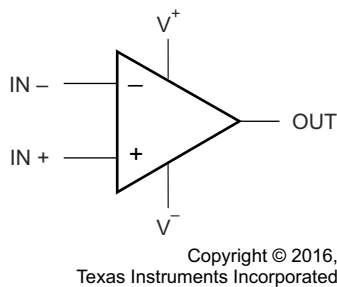
where

- A_{OL} is the open-loop gain of the amplifier, typically around 100dB (100,000x, or 10uV per Volt).

To reduce the power supply current drain, the amplifiers have a class A output stage for small signal levels which converts to class B in a large signal mode. This allows the amplifiers to both source and sink large output currents. Therefore both NPN and PNP external current boost transistors can be used to extend the power capability of the basic amplifiers. The output voltage needs to raise approximately 1 diode drop above ground to bias the on-chip vertical PNP transistor for output current sinking applications.

For ac applications, where the load is capacitively coupled to the output of the amplifier, a resistor should be used, from the output of the amplifier to ground to increase the class A bias current and prevent crossover distortion. Where the load is directly coupled, as in dc applications, there is no crossover distortion.

Capacitive loads which are applied directly to the output of the amplifier reduce the loop stability margin. Values of 50 pF can be accommodated using the worst-case non-inverting unity gain connection. Large closed loop gains or resistive isolation should be used if larger load capacitance must be driven by the amplifier.

The bias network of the LM158 establishes a drain current which is independent of the magnitude of the power supply voltage over the range of $3 V_{DC}$ to $30 V_{DC}$.

Output short circuits either to ground or to the positive power supply should be of short time duration. Units can be destroyed, not as a result of the short circuit current causing metal fusing, but rather due to the large increase in IC chip power dissipation which will cause eventual failure due to excessive junction temperatures. Putting

8 Application and Implementation

备注

Information in the following applications sections is not part of the TI component specification, and TI does not warrant its accuracy or completeness. TI's customers are responsible for determining suitability of components for their purposes. Customers should validate and test their design implementation to confirm system functionality.

8.1 Application Information

The LM158 family bring performance, economy, and ease-of-use to a wide variety of op-amp applications.

8.2 Typical Applications

8.2.1 Noninverting DC Gain

图 8-1 shows a high input impedance non-inverting circuit. This circuit gives a closed-loop gain equal to the ratio of the sum of R1 and R2 to R1 and a closed-loop 3 dB bandwidth equal to the amplifier unity-gain frequency divided by the closed-loop gain. This design has the benefit of a very high input impedance, which is equal to the differential input impedance multiplied by loop gain. (Open loop gain/Closed loop gain.) In DC coupled applications, input impedance is not as important as input current and its voltage drop across the source resistance. Note that the amplifier output will go into saturation if the input is allowed to float. This may be important if the amplifier must be switched from source to source.

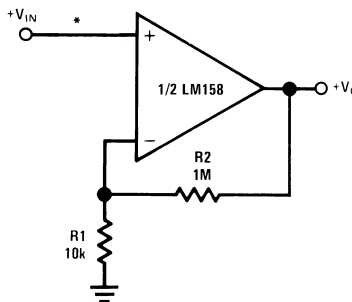

*R not needed due to temperature independent I_{IN}

图 8-1. Non-Inverting DC Gain (0-V Output)

8.2.1.1 Design Requirements

For this example application, the supply voltage is +5V, and $100x \pm 5\%$ of noninverting gain is necessary. Signal input impedance is approx $10k \Omega$.

8.2.1.2 Detailed Design Procedure

Using the equation for a non-inverting amplifier configuration ; $G = 1 + R2/R1$, set R1 to $10k \Omega$, and R2 to 99x the value of R1, which would be $990k \Omega$. Replacing the $990k \Omega$ with a $1M \Omega$ will result in a gain of 101, which is within the desired gain tolerance.

The gain-frequency characteristic of the amplifier and its feedback network must be such that oscillation does not occur. To meet this condition, the phase shift through amplifier and feedback network must never exceed 180° for any frequency where the gain of the amplifier and its feedback network is greater than unity. In practical applications, the phase shift should not approach 180° since this is the situation of conditional stability. Obviously the most critical case occurs when the attenuation of the feedback network is zero.

8.2.1.3 Application Curve



图 8-2. Transfer Curve for Non-Inverting Configuration

8.2.2 System Examples

8.2.2.1 Typical Single-Supply Applications

($V^+ = 5.0 V_{DC}$)

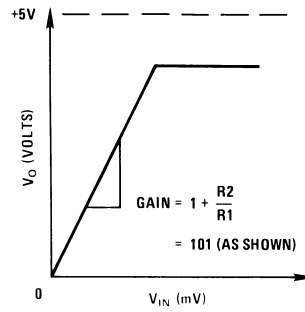
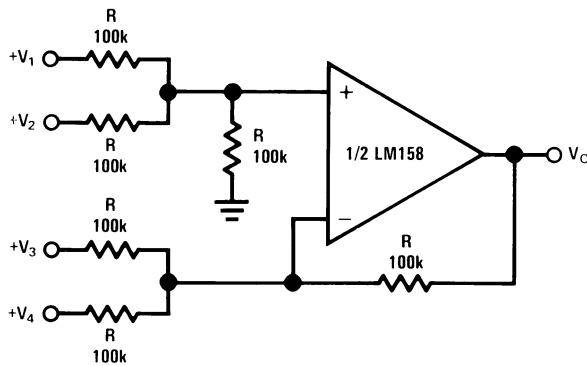

Where: $V_O = V_1 + V_2 - V_3 - V_4$
 $(V_1 + V_2) \geq (V_3 + V_4)$ to keep $V_O > 0 V_{DC}$

图 8-3. DC Summing Amplifier
 $(V_{IN}'S \geq 0 V_{DC}$ and $V_O \geq 0 V_{DC}$)

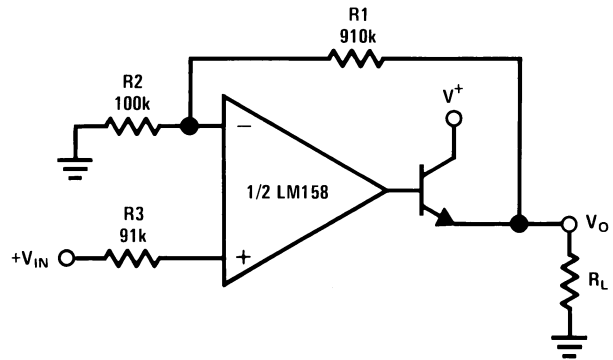

$V_O = 0 V_{DC}$ for $V_{IN} = 0 V_{DC}$
 $A_V = 10$

图 8-4. Power Amplifier

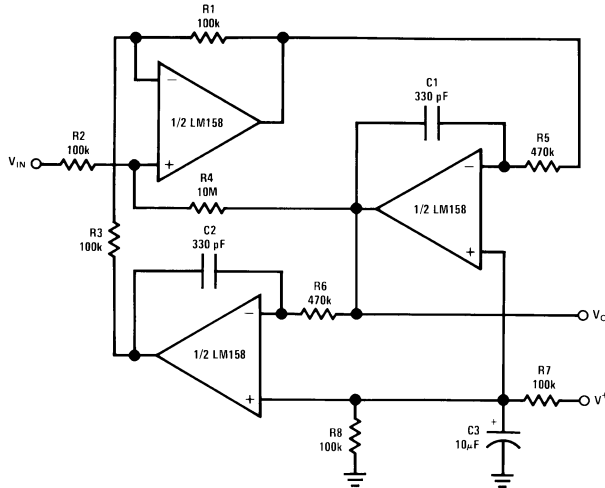

$f_o = 1 \text{ kHz}$
 $Q = 50$
 $A_v = 100 \text{ (40 dB)}$

图 8-5. “BI-QUAD” RC Active Bandpass Filter



图 8-6. Lamp Driver



图 8-7. LED Driver

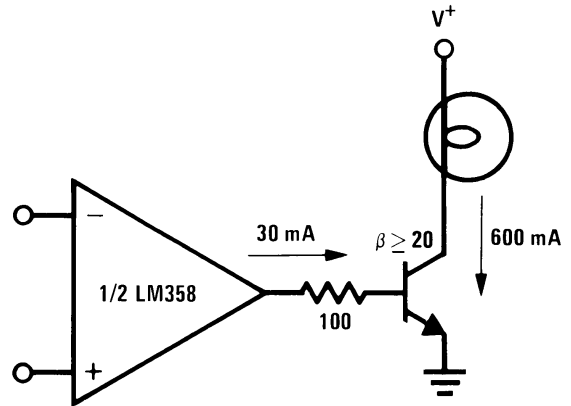

图 8-8. Driving TTL

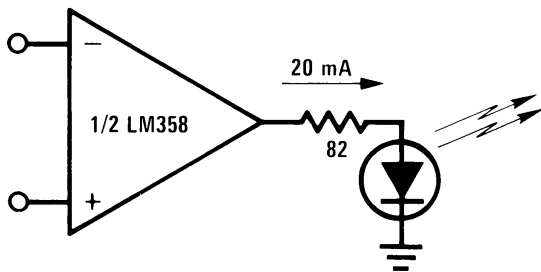

图 8-9. Voltage Follower

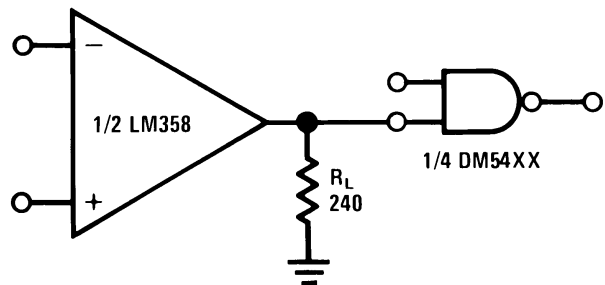

图 8-10. Pulse Generator

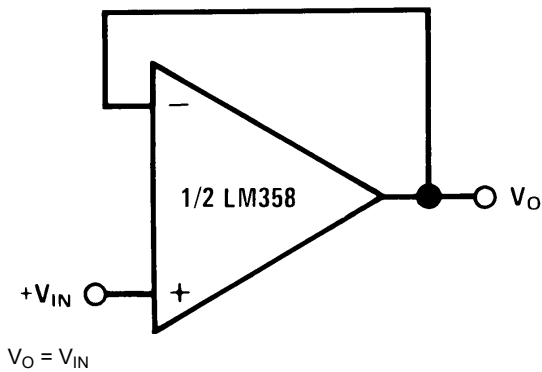

图 8-11. Squarewave Oscillator

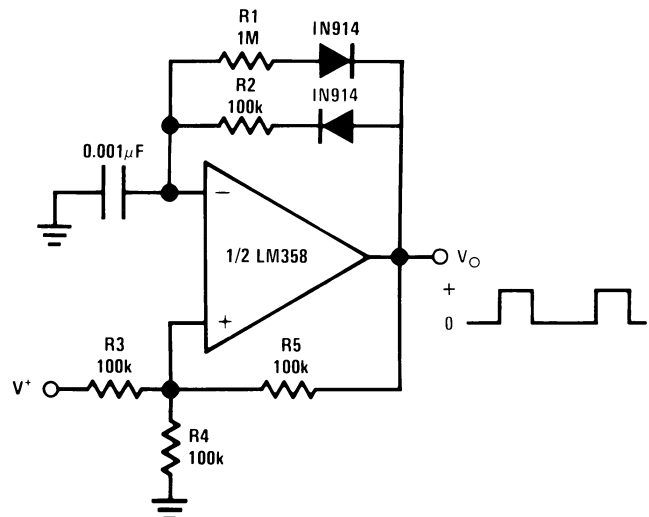

图 8-12. Pulse Generator

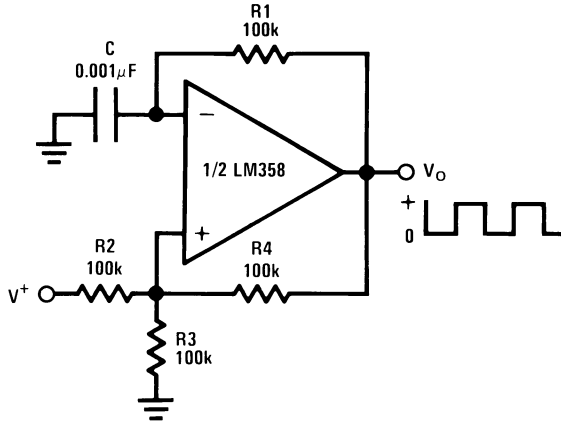

HIGH Z_{IN}
LOW Z_{OUT}

图 8-13. Low Drift Peak Detector

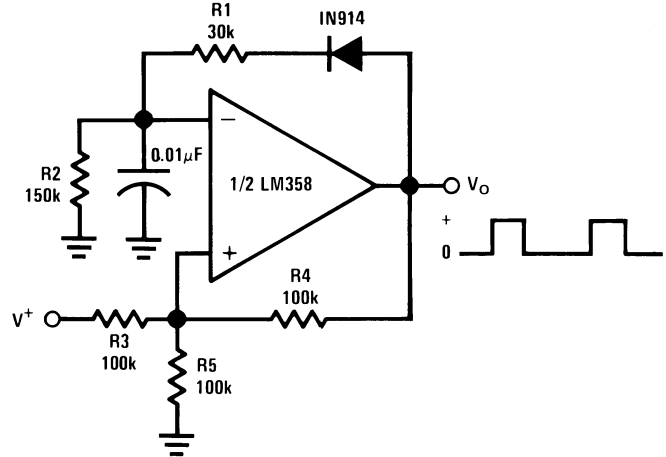
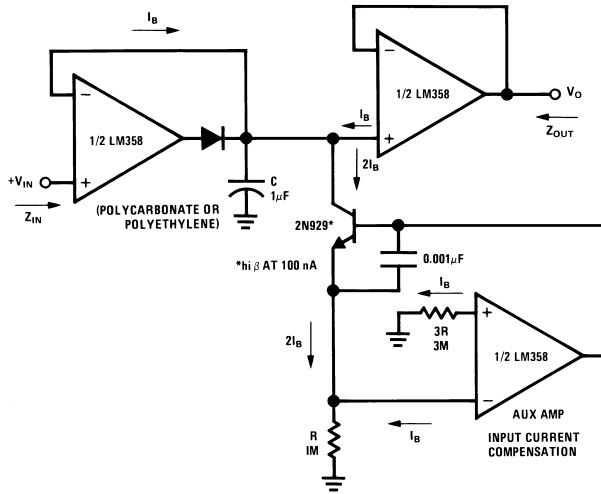
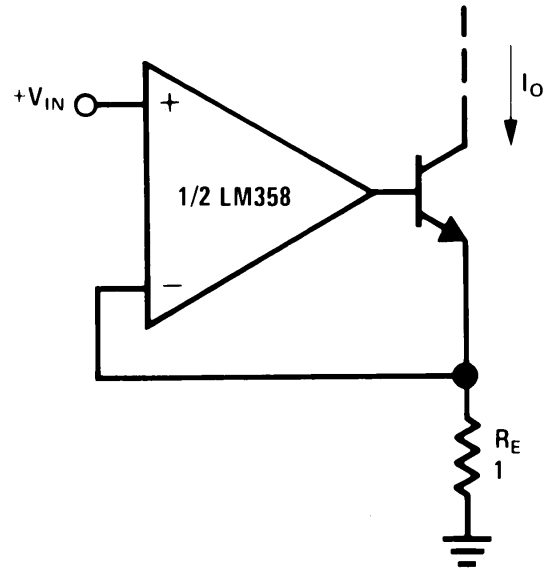

$I_O = 1 \text{ amp/volt } V_{IN}$
(Increase R_E for I_O small)

图 8-14. High Compliance Current Sink



图 8-15. Comparator with Hysteresis



*WIDE CONTROL VOLTAGE RANGE: $0 V_{DC} \leq V_C \leq 2 (V^+ - 1.5V_{DC})$

图 8-16. Voltage Controlled Oscillator (VCO)

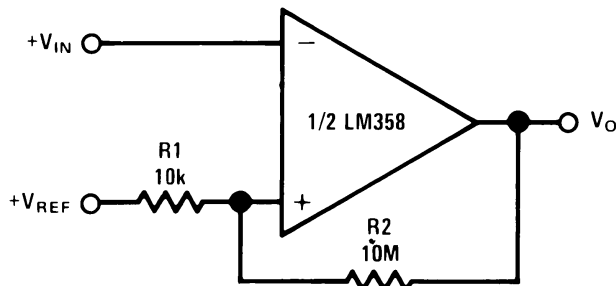
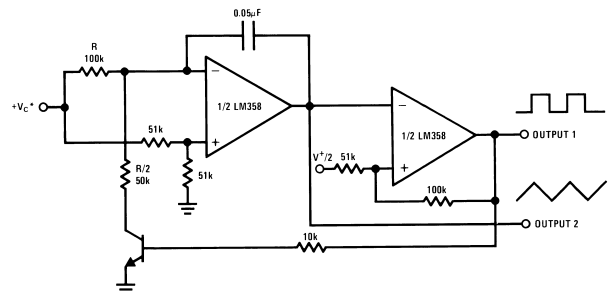

图 8-17. Ground Referencing a Differential Input Signal



$f_o = 1 \text{ kHz}$
 $Q = 1$
 $A_V = 2$

图 8-18. DC Coupled Low-Pass RC Active Filter

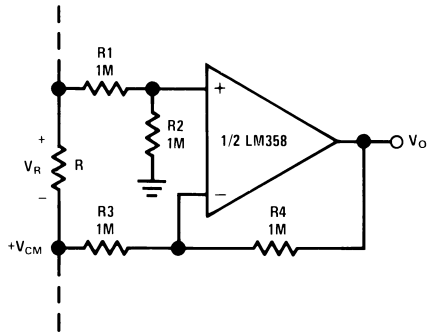
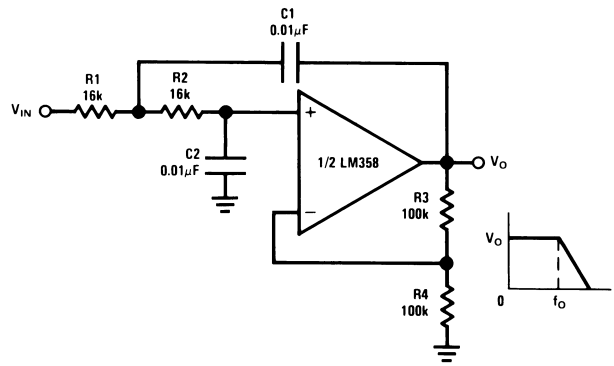
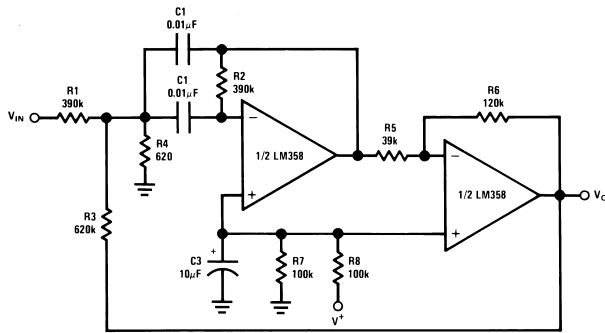

$f_o = 1 \text{ kHz}$
 $Q = 25$

图 8-19. Bandpass Active Filter



图 8-20. Photo Voltaic-Cell Amplifier



图 8-21. Using Symmetrical Amplifiers to Reduce Input Current (General Concept)

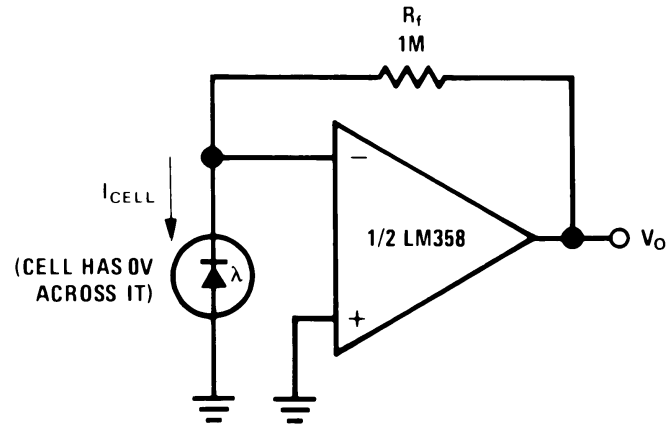

图 8-22. Fixed Current Sources

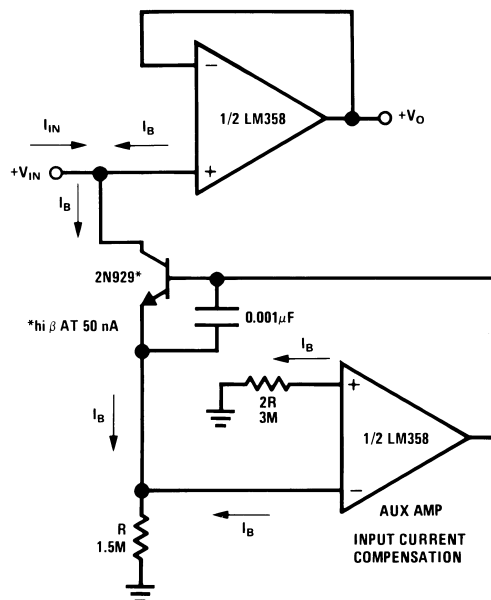

*(Increase R1 for I_L small)

$$V_L \leq V^+ - 2V$$

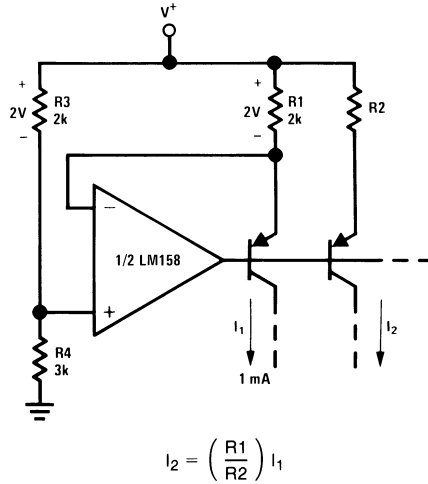
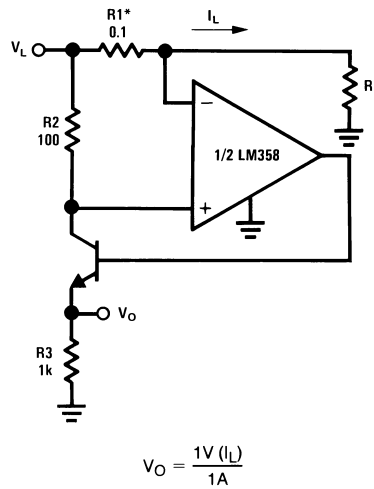
图 8-23. Current Monitor



图 8-24. AC Coupled Inverting Amplifier



$A_V = 11$ (As Shown)

图 8-25. AC Coupled Non-Inverting Amplifier

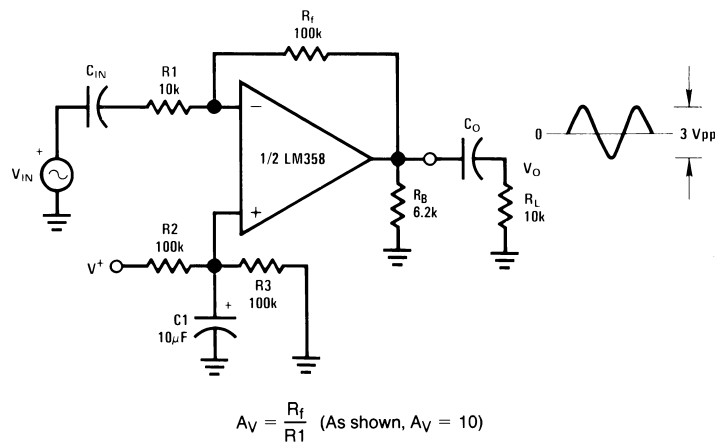
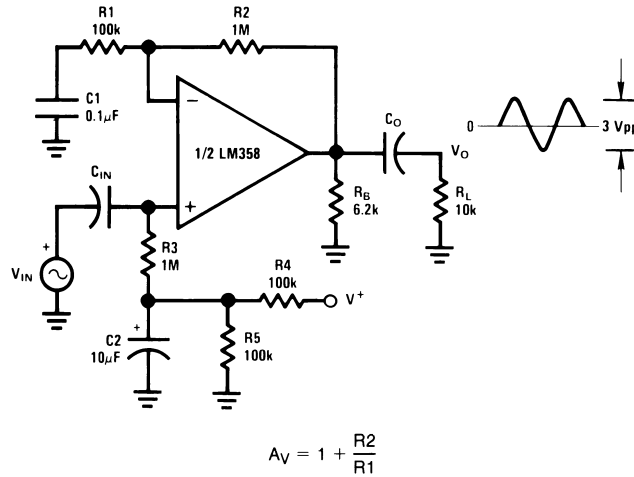

图 8-26. High Input Z, DC Differential Amplifier



图 8-27. Bridge Current Amplifier

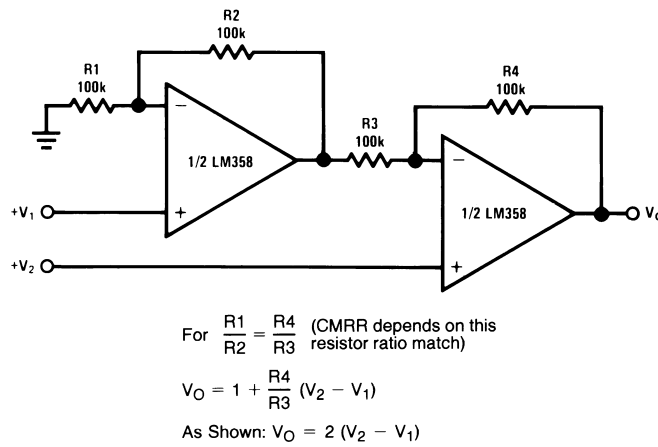

If $R1 = R5$ & $R3 = R4 = R6 = R7$ (CMRR depends on match)

$$V_O = 1 + \frac{2R1}{R2} (V_2 - V_1)$$

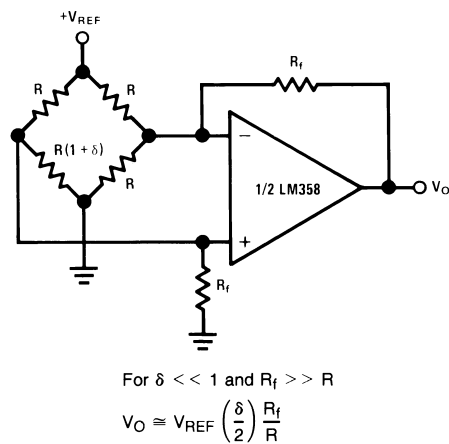
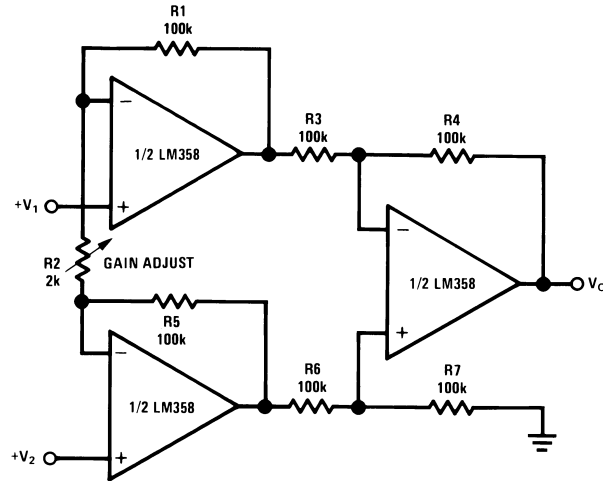
As shown $V_O = 101 (V_2 - V_1)$

图 8-28. High Input Z Adjustable-Gain DC Instrumentation Amplifier

9 Power Supply Recommendations

For proper operation, the power supplies must be properly decoupled. For decoupling the supply pins it is suggested that 10-nF capacitors be placed as close as possible to the op-amp power supply pins. For single supply, place a capacitor between V+ and V- supply leads. For dual supplies, place one capacitor between V+ and ground, and one capacitor between V- and ground.

Precautions should be taken to insure that the power supply for the integrated circuit never becomes reversed in polarity or that the unit is not inadvertently installed backwards in a test socket as an unlimited current surge through the resulting forward diode within the IC could cause fusing of the internal conductors and result in a destroyed unit.

10 Layout

10.1 Layout Guidelines

For single-ended supply configurations, the V+ pin should be bypassed to ground with a low ESR capacitor. The optimum placement is closest to the V+ pin. Care should be taken to minimize the loop area formed by the bypass capacitor connection between V+ and ground. The ground pin should be connected to the PCB ground plane at the pin of the device. The feedback components should be placed as close to the device as possible to minimize stray parasitics.

For dual supply configurations, both the V+ pin and V- pin should be bypassed to ground with a low ESR capacitor. The optimum placement is closest to the corresponding supply pin. Care should be taken to minimize the loop area formed by the bypass capacitor connection between V+ or V- and ground. The feedback components should be placed as close to the device as possible to minimize stray parasitics.

For both configurations, as ground plane underneath the device is recommended.

10.2 Layout Example



图 10-1. Layout Example

11 Device and Documentation Support

11.1 接收文档更新通知

要接收文档更新通知，请导航至 ti.com 上的器件产品文件夹。点击 [订阅更新](#) 进行注册，即可每周接收产品信息更改摘要。有关更改的详细信息，请查看任何已修订文档中包含的修订历史记录。

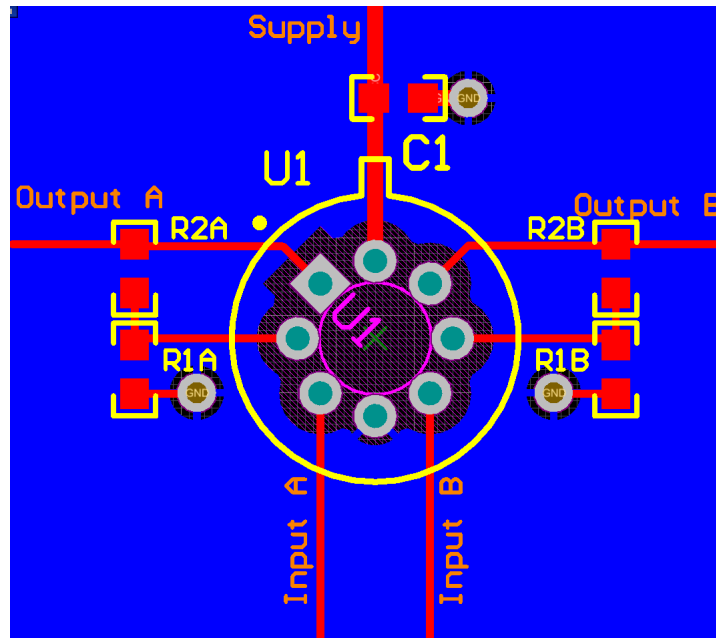
11.2 支持资源

[TI E2E™ 支持论坛](#) 是工程师的重要参考资料，可直接从专家获得快速、经过验证的解答和设计帮助。搜索现有解答或提出自己的问题可获得所需的快速设计帮助。

链接的内容由各个贡献者“按原样”提供。这些内容并不构成 TI 技术规范，并且不一定反映 TI 的观点；请参阅 TI 的《[使用条款](#)》。

11.3 Trademarks

TI E2E™ is a trademark of Texas Instruments.

所有商标均为其各自所有者的财产。

11.4 Electrostatic Discharge Caution



This integrated circuit can be damaged by ESD. Texas Instruments recommends that all integrated circuits be handled with appropriate precautions. Failure to observe proper handling and installation procedures can cause damage.

ESD damage can range from subtle performance degradation to complete device failure. Precision integrated circuits may be more susceptible to damage because very small parametric changes could cause the device not to meet its published specifications.

11.5 术语表

[TI 术语表](#) 本术语表列出并解释了术语、首字母缩略词和定义。

12 Mechanical, Packaging, and Orderable Information

The following pages include mechanical, packaging, and orderable information. This information is the most current data available for the designated devices. This data is subject to change without notice and revision of this document. For browser-based versions of this data sheet, refer to the left-hand navigation.

PACKAGING INFORMATION

Orderable Device	Status (1)	Package Type	Package Drawing	Pins	Package Qty	Eco Plan (2)	Lead finish/ Ball material (6)	MSL Peak Temp (3)	Op Temp (°C)	Device Marking (4/5)	Samples
LM158AH	ACTIVE	TO-99	LMC	8	500	Non-RoHS & Non-Green	Call TI	Call TI	-55 to 125	(LM158AH, LM158AH)	Samples
LM158AH/NOPB	ACTIVE	TO-99	LMC	8	500	RoHS & Green	Call TI	Level-1-NA-UNLIM	-55 to 125	(LM158AH, LM158AH)	Samples
LM158H	ACTIVE	TO-99	LMC	8	500	Non-RoHS & Non-Green	Call TI	Call TI	-55 to 125	(LM158H, LM158H)	Samples
LM158H/NOPB	ACTIVE	TO-99	LMC	8	500	RoHS & Green	Call TI	Level-1-NA-UNLIM	-55 to 125	(LM158H, LM158H)	Samples
LM158J	ACTIVE	CDIP	NAB	8	40	Non-RoHS & Green	Call TI	Level-1-NA-UNLIM	-55 to 125	LM158J	Samples
LM258H	ACTIVE	TO-99	LMC	8	500	Non-RoHS & Non-Green	Call TI	Call TI	-25 to 85	(LM258H, LM258H)	Samples
LM258H/NOPB	ACTIVE	TO-99	LMC	8	500	RoHS & Green	Call TI	Level-1-NA-UNLIM	-25 to 85	(LM258H, LM258H)	Samples
LM2904ITP/NOPB	ACTIVE	DSBGA	YPB	8	250	RoHS & Green	SNAGCU	Level-1-260C-UNLIM	-40 to 85	A 09	Samples
LM2904ITPX/NOPB	ACTIVE	DSBGA	YPB	8	3000	RoHS & Green	SNAGCU	Level-1-260C-UNLIM	-40 to 85	A 09	Samples
LM2904M/NOPB	ACTIVE	SOIC	D	8	95	RoHS & Green	SN	Level-1-260C-UNLIM	-40 to 85	LM 2904M	Samples
LM2904MX	NRND	SOIC	D	8	2500	Non-RoHS & Green	Call TI	Level-1-235C-UNLIM	-40 to 85	LM 2904M	
LM2904MX/NOPB	ACTIVE	SOIC	D	8	2500	RoHS & Green	SN	Level-1-260C-UNLIM	-40 to 85	LM 2904M	Samples
LM2904N/NOPB	ACTIVE	PDIP	P	8	40	RoHS & Green	NIPDAU	Level-1-NA-UNLIM	-40 to 85	LM 2904N	Samples
LM358AM	NRND	SOIC	D	8	95	Non-RoHS & Green	Call TI	Level-1-235C-UNLIM	0 to 70	LM 358AM	
LM358AM/NOPB	ACTIVE	SOIC	D	8	95	RoHS & Green	SN	Level-1-260C-UNLIM	0 to 70	LM 358AM	Samples
LM358AMX	NRND	SOIC	D	8	2500	Non-RoHS & Green	Call TI	Level-1-235C-UNLIM	0 to 70	LM 358AM	
LM358AMX/NOPB	ACTIVE	SOIC	D	8	2500	RoHS & Green	SN	Level-1-260C-UNLIM	0 to 70	LM 358AM	Samples

Orderable Device	Status (1)	Package Type	Package Drawing	Pins	Package Qty	Eco Plan (2)	Lead finish/ Ball material (6)	MSL Peak Temp (3)	Op Temp (°C)	Device Marking (4/5)	Samples
LM358AN/NOPB	ACTIVE	PDIP	P	8	40	RoHS & Green	NIPDAU	Level-1-NA-UNLIM	0 to 70	LM358AN	Samples
LM358H/NOPB	ACTIVE	TO-99	LMC	8	500	RoHS & Green	Call TI	Level-1-NA-UNLIM	0 to 70	(LM358H, LM358H)	Samples
LM358M	NRND	SOIC	D	8	95	Non-RoHS & Green	Call TI	Level-1-235C-UNLIM	0 to 70	LM358M	
LM358M/NOPB	ACTIVE	SOIC	D	8	95	RoHS & Green	SN	Level-1-260C-UNLIM	0 to 70	LM358M	Samples
LM358MX	NRND	SOIC	D	8	2500	Non-RoHS & Green	Call TI	Level-1-235C-UNLIM	0 to 70	LM358M	
LM358MX/NOPB	ACTIVE	SOIC	D	8	2500	RoHS & Green	SN	Level-1-260C-UNLIM	0 to 70	LM358M	Samples
LM358N/NOPB	ACTIVE	PDIP	P	8	40	RoHS & Green	NIPDAU	Level-1-NA-UNLIM	0 to 70	LM358N	Samples
LM358TP/NOPB	ACTIVE	DSBGA	YPB	8	250	RoHS & Green	SNAGCU	Level-1-260C-UNLIM	0 to 70	A07	Samples
LM358TPX/NOPB	ACTIVE	DSBGA	YPB	8	3000	RoHS & Green	SNAGCU	Level-1-260C-UNLIM	0 to 70	A07	Samples

(1) The marketing status values are defined as follows:

ACTIVE: Product device recommended for new designs.

LIFEBUY: TI has announced that the device will be discontinued, and a lifetime-buy period is in effect.

NRND: Not recommended for new designs. Device is in production to support existing customers, but TI does not recommend using this part in a new design.

PREVIEW: Device has been announced but is not in production. Samples may or may not be available.

OBSELETE: TI has discontinued the production of the device.

(2) **RoHS:** TI defines "RoHS" to mean semiconductor products that are compliant with the current EU RoHS requirements for all 10 RoHS substances, including the requirement that RoHS substance do not exceed 0.1% by weight in homogeneous materials. Where designed to be soldered at high temperatures, "RoHS" products are suitable for use in specified lead-free processes. TI may reference these types of products as "Pb-Free".

RoHS Exempt: TI defines "RoHS Exempt" to mean products that contain lead but are compliant with EU RoHS pursuant to a specific EU RoHS exemption.

Green: TI defines "Green" to mean the content of Chlorine (Cl) and Bromine (Br) based flame retardants meet JS709B low halogen requirements of <=1000ppm threshold. Antimony trioxide based flame retardants must also meet the <=1000ppm threshold requirement.

(3) MSL, Peak Temp. - The Moisture Sensitivity Level rating according to the JEDEC industry standard classifications, and peak solder temperature.

(4) There may be additional marking, which relates to the logo, the lot trace code information, or the environmental category on the device.

(5) Multiple Device Markings will be inside parentheses. Only one Device Marking contained in parentheses and separated by a "~" will appear on a device. If a line is indented then it is a continuation of the previous line and the two combined represent the entire Device Marking for that device.

(6) Lead finish/Ball material - Orderable Devices may have multiple material finish options. Finish options are separated by a vertical ruled line. Lead finish/Ball material values may wrap to two lines if the finish value exceeds the maximum column width.

Important Information and Disclaimer:The information provided on this page represents TI's knowledge and belief as of the date that it is provided. TI bases its knowledge and belief on information provided by third parties, and makes no representation or warranty as to the accuracy of such information. Efforts are underway to better integrate information from third parties. TI has taken and continues to take reasonable steps to provide representative and accurate information but may not have conducted destructive testing or chemical analysis on incoming materials and chemicals. TI and TI suppliers consider certain information to be proprietary, and thus CAS numbers and other limited information may not be available for release.

In no event shall TI's liability arising out of such information exceed the total purchase price of the TI part(s) at issue in this document sold by TI to Customer on an annual basis.

OTHER QUALIFIED VERSIONS OF LM2904-N :

- Automotive : [LM2904-Q1](#)
- Enhanced Product : [LM2904-EP](#)

NOTE: Qualified Version Definitions:

- Automotive - Q100 devices qualified for high-reliability automotive applications targeting zero defects
- Enhanced Product - Supports Defense, Aerospace and Medical Applications

TAPE AND REEL INFORMATION

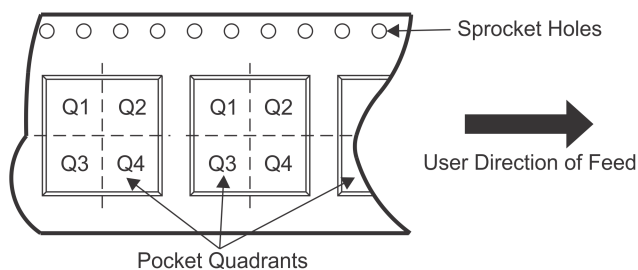
QUADRANT ASSIGNMENTS FOR PIN 1 ORIENTATION IN TAPE

*All dimensions are nominal

Device	Package Type	Package Drawing	Pins	SPQ	Reel Diameter (mm)	Reel Width W1 (mm)	A0 (mm)	B0 (mm)	K0 (mm)	P1 (mm)	W (mm)	Pin1 Quadrant
LM2904ITP/NOPB	DSBGA	YPB	8	250	178.0	8.4	1.5	1.5	0.66	4.0	8.0	Q1
LM2904ITPX/NOPB	DSBGA	YPB	8	3000	178.0	8.4	1.5	1.5	0.66	4.0	8.0	Q1
LM2904MX	SOIC	D	8	2500	330.0	12.4	6.5	5.4	2.0	8.0	12.0	Q1
LM2904MX/NOPB	SOIC	D	8	2500	330.0	12.4	6.5	5.4	2.0	8.0	12.0	Q1
LM358AMX	SOIC	D	8	2500	330.0	12.4	6.5	5.4	2.0	8.0	12.0	Q1
LM358AMX/NOPB	SOIC	D	8	2500	330.0	12.4	6.5	5.4	2.0	8.0	12.0	Q1
LM358MX	SOIC	D	8	2500	330.0	12.4	6.5	5.4	2.0	8.0	12.0	Q1
LM358MX/NOPB	SOIC	D	8	2500	330.0	12.4	6.5	5.4	2.0	8.0	12.0	Q1
LM358TP/NOPB	DSBGA	YPB	8	250	178.0	8.4	1.5	1.5	0.66	4.0	8.0	Q1
LM358TPX/NOPB	DSBGA	YPB	8	3000	178.0	8.4	1.5	1.5	0.66	4.0	8.0	Q1

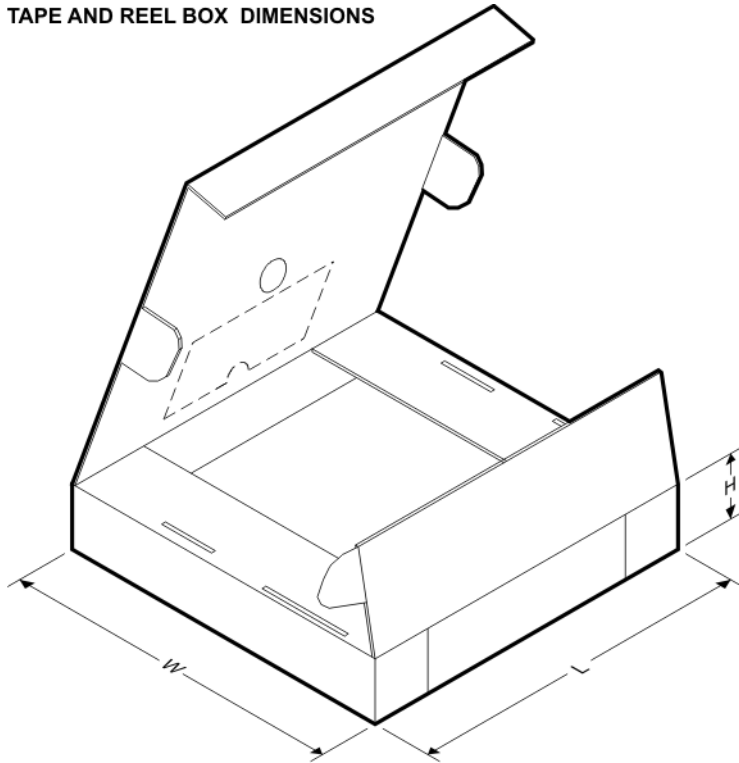
TAPE AND REEL BOX DIMENSIONS

*All dimensions are nominal

Device	Package Type	Package Drawing	Pins	SPQ	Length (mm)	Width (mm)	Height (mm)
LM2904ITP/NOPB	DSBGA	YPB	8	250	208.0	191.0	35.0
LM2904ITPX/NOPB	DSBGA	YPB	8	3000	208.0	191.0	35.0
LM2904MX	SOIC	D	8	2500	367.0	367.0	35.0
LM2904MX/NOPB	SOIC	D	8	2500	367.0	367.0	35.0
LM358AMX	SOIC	D	8	2500	367.0	367.0	35.0
LM358AMX/NOPB	SOIC	D	8	2500	367.0	367.0	35.0
LM358MX	SOIC	D	8	2500	367.0	367.0	35.0
LM358MX/NOPB	SOIC	D	8	2500	367.0	367.0	35.0
LM358TP/NOPB	DSBGA	YPB	8	250	208.0	191.0	35.0
LM358TPX/NOPB	DSBGA	YPB	8	3000	208.0	191.0	35.0

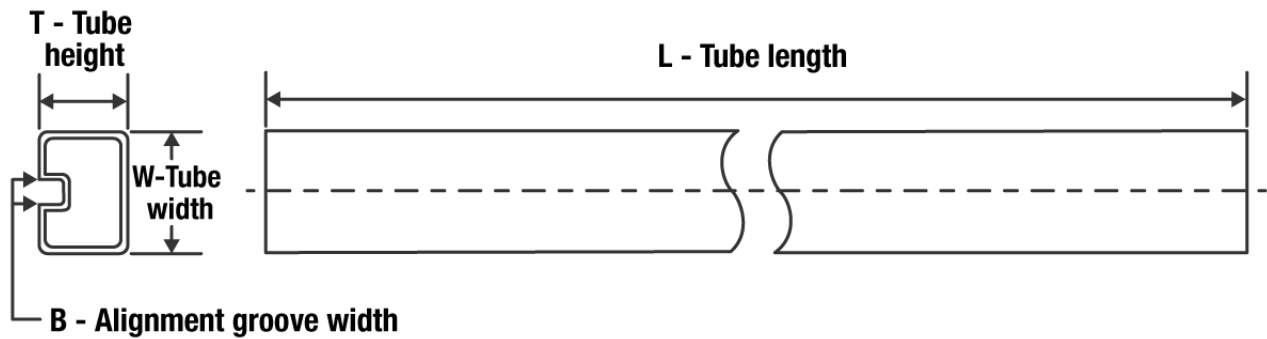
TUBE

*All dimensions are nominal

Device	Package Name	Package Type	Pins	SPQ	L (mm)	W (mm)	T (μm)	B (mm)
LM158J	NAB	CDIP	8	40	502	14	11938	4.32
LM2904M/NOPB	D	SOIC	8	95	495	8	4064	3.05
LM2904N/NOPB	P	PDIP	8	40	502	14	11938	4.32
LM358AM	D	SOIC	8	95	495	8	4064	3.05
LM358AM	D	SOIC	8	95	495	8	4064	3.05
LM358AM/NOPB	D	SOIC	8	95	495	8	4064	3.05
LM358AN/NOPB	P	PDIP	8	40	502	14	11938	4.32
LM358M	D	SOIC	8	95	495	8	4064	3.05
LM358M	D	SOIC	8	95	495	8	4064	3.05
LM358M/NOPB	D	SOIC	8	95	495	8	4064	3.05
LM358N/NOPB	P	PDIP	8	40	502	14	11938	4.32

NAB0008A

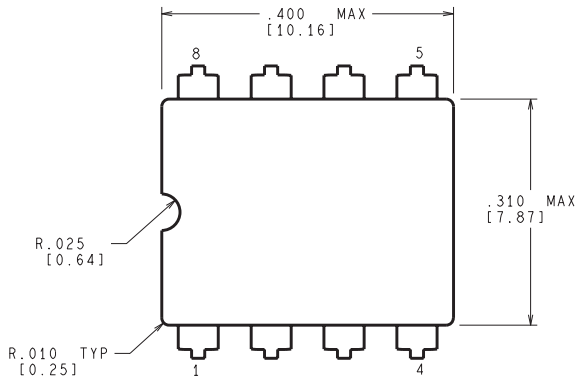

CONTROLLING DIMENSION IS INCH
VALUES IN [] ARE MILLIMETERS

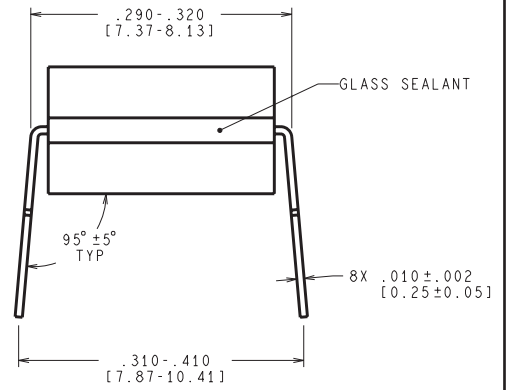
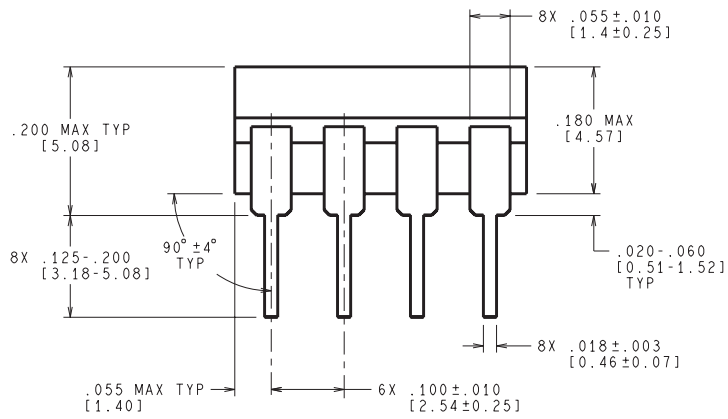

J08A (Rev M)



D0008A

PACKAGE OUTLINE

SOIC - 1.75 mm max height

SMALL OUTLINE INTEGRATED CIRCUIT



4214825/C 02/2019

NOTES:

1. Linear dimensions are in inches [millimeters]. Dimensions in parenthesis are for reference only. Controlling dimensions are in inches. Dimensioning and tolerancing per ASME Y14.5M.
2. This drawing is subject to change without notice.
3. This dimension does not include mold flash, protrusions, or gate burrs. Mold flash, protrusions, or gate burrs shall not exceed .006 [0.15] per side.
4. This dimension does not include interlead flash.
5. Reference JEDEC registration MS-012, variation AA.

EXAMPLE BOARD LAYOUT

D0008A

SOIC - 1.75 mm max height

SMALL OUTLINE INTEGRATED CIRCUIT



LAND PATTERN EXAMPLE
 EXPOSED METAL SHOWN
 SCALE:8X



SOLDER MASK DETAILS

4214825/C 02/2019

NOTES: (continued)

- 6. Publication IPC-7351 may have alternate designs.
- 7. Solder mask tolerances between and around signal pads can vary based on board fabrication site.

EXAMPLE STENCIL DESIGN

D0008A

SOIC - 1.75 mm max height

SMALL OUTLINE INTEGRATED CIRCUIT



SOLDER PASTE EXAMPLE
BASED ON .005 INCH [0.125 MM] THICK STENCIL
SCALE:8X

4214825/C 02/2019

NOTES: (continued)

8. Laser cutting apertures with trapezoidal walls and rounded corners may offer better paste release. IPC-7525 may have alternate design recommendations.
9. Board assembly site may have different recommendations for stencil design.

P (R-PDIP-T8)

PLASTIC DUAL-IN-LINE PACKAGE



- NOTES:
- A. All linear dimensions are in inches (millimeters).
 - B. This drawing is subject to change without notice.
 - C. Falls within JEDEC MS-001 variation BA.

YPB0008

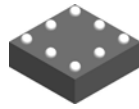

PACKAGE OUTLINE

DSBGA - 0.575 mm max height

DIE SIZE BALL GRID ARRAY

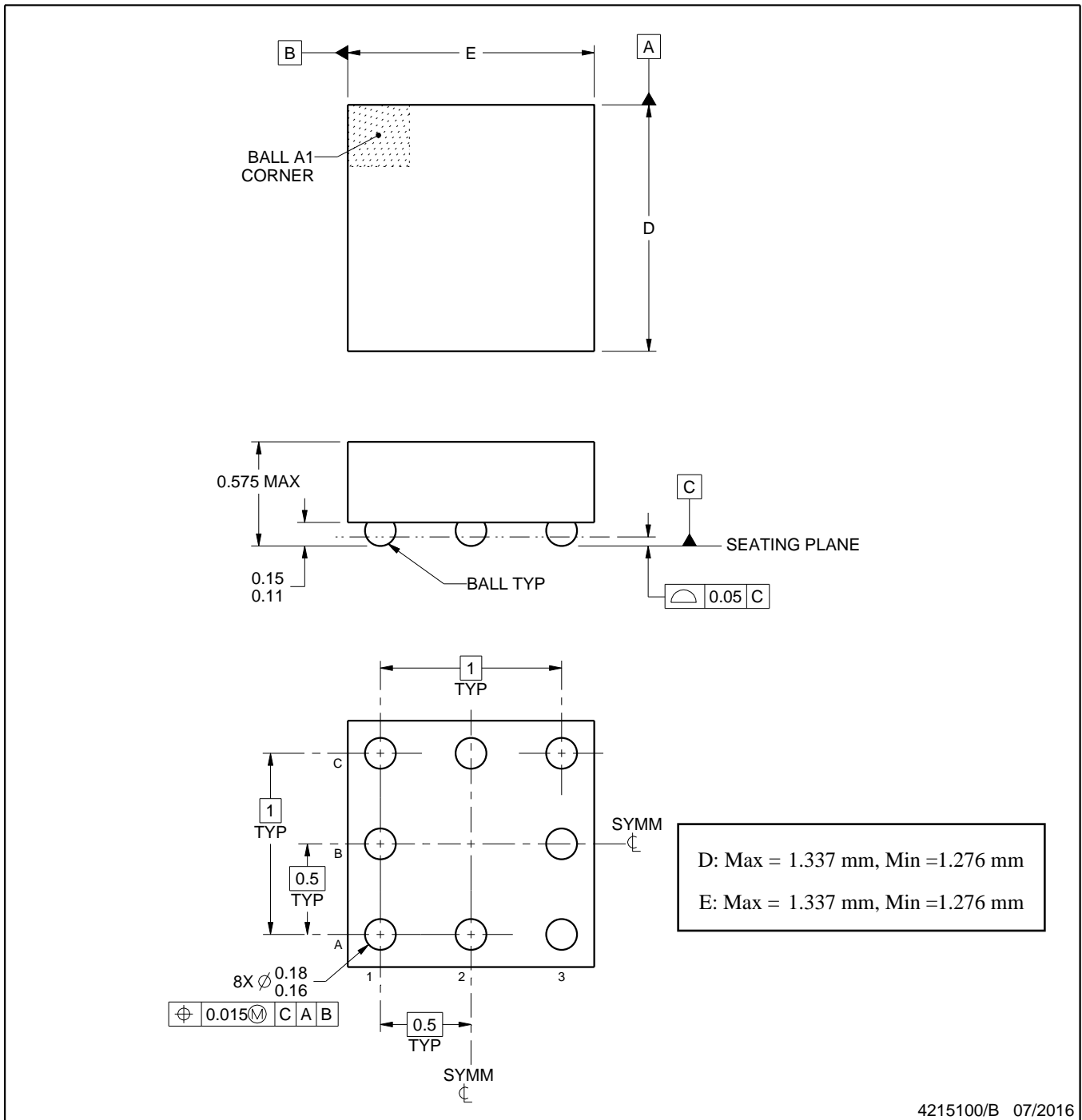

NOTES:

1. All linear dimensions are in millimeters. Any dimensions in parenthesis are for reference only. Dimensioning and tolerancing per ASME Y14.5M.
2. This drawing is subject to change without notice.

EXAMPLE BOARD LAYOUT

YPB0008

DSBGA - 0.575 mm max height

DIE SIZE BALL GRID ARRAY

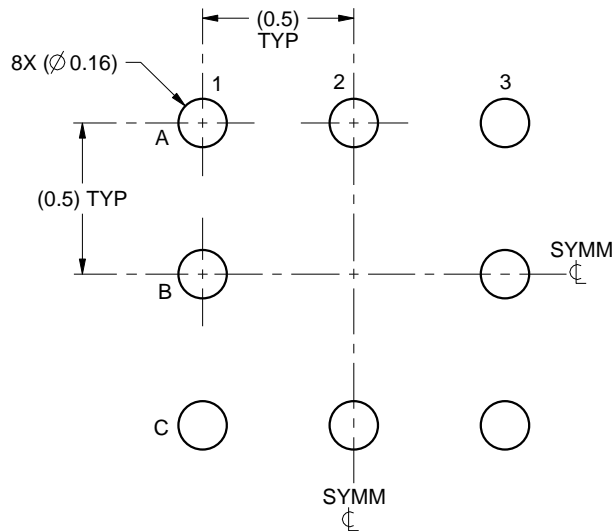

LAND PATTERN EXAMPLE
SCALE:40X

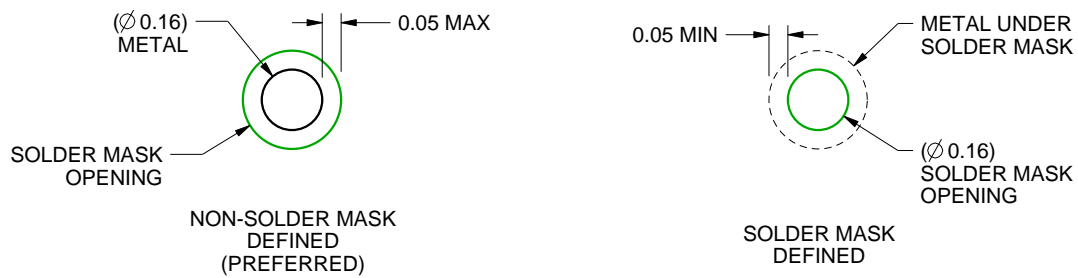

SOLDER MASK DETAILS
NOT TO SCALE

4215100/B 07/2016

NOTES: (continued)

- Final dimensions may vary due to manufacturing tolerance considerations and also routing constraints. See Texas Instruments Literature No. SNVA009 (www.ti.com/lit/snva009).

EXAMPLE STENCIL DESIGN

YPB0008

DSBGA - 0.575 mm max height

DIE SIZE BALL GRID ARRAY

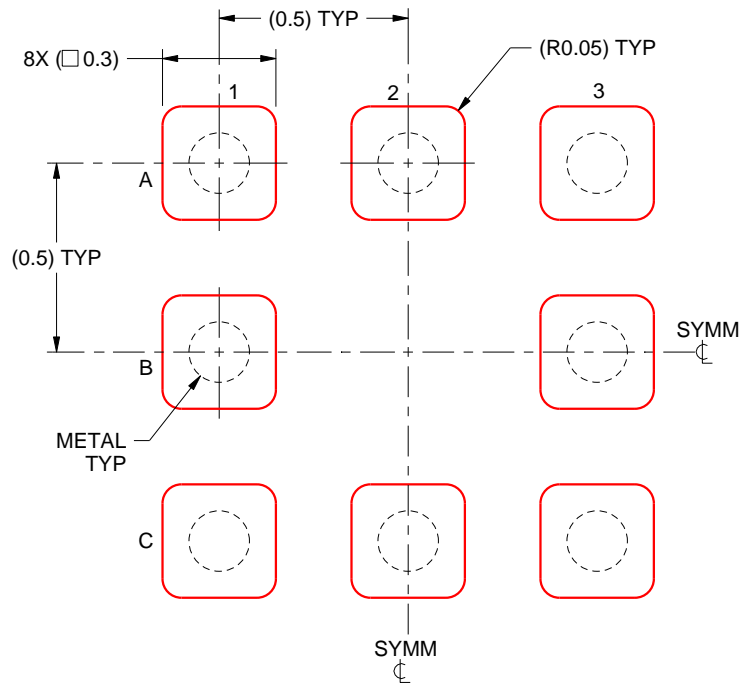

SOLDER PASTE EXAMPLE
BASED ON 0.125mm THICK STENCIL
SCALE:50X

4215100/B 07/2016

NOTES: (continued)

4. Laser cutting apertures with trapezoidal walls and rounded corners may offer better paste release.

LMC (O-MBCY-W8)

METAL CYLINDRICAL PACKAGE

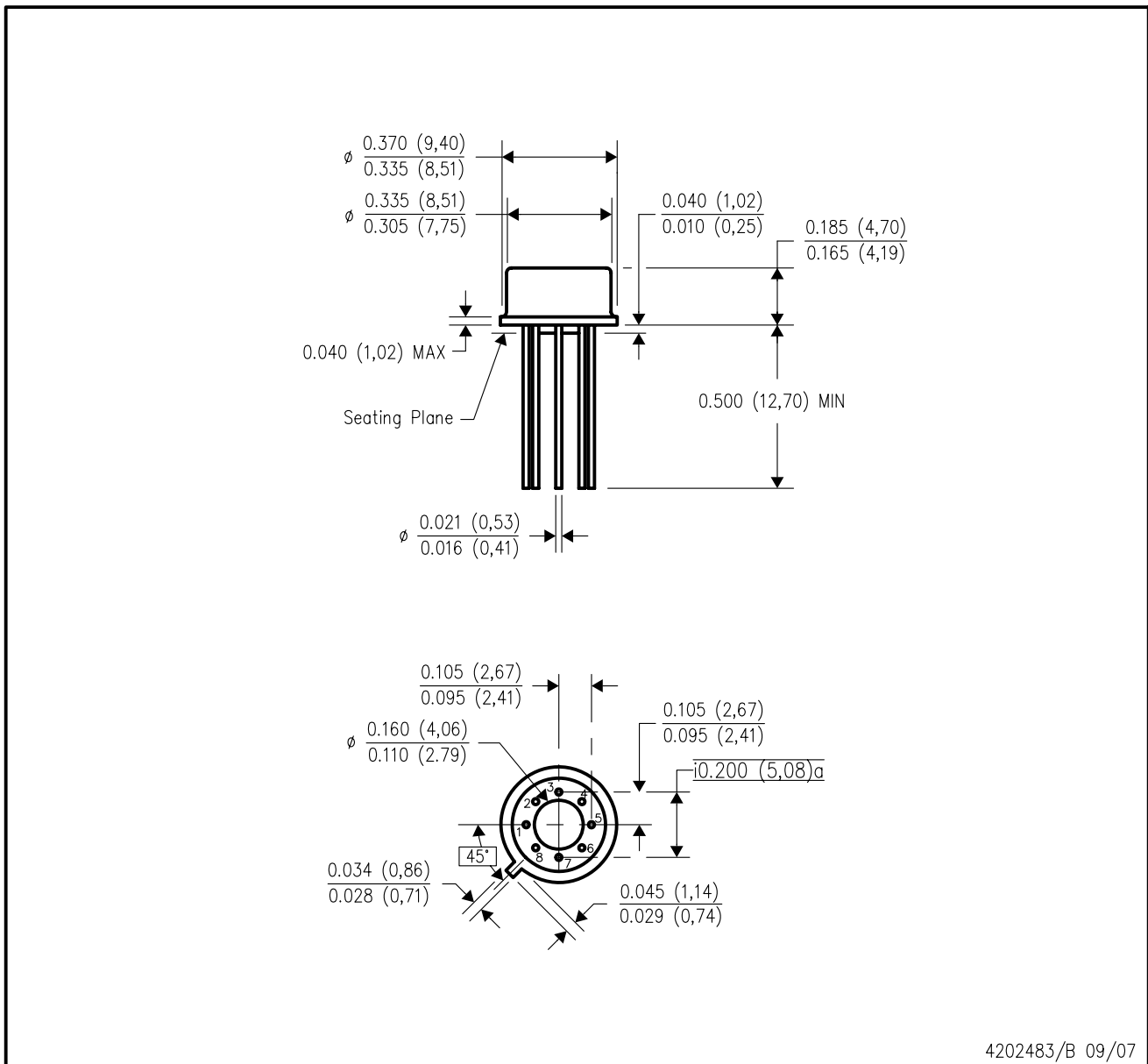

- NOTES:
- A. All linear dimensions are in inches (millimeters).
 - B. This drawing is subject to change without notice.
 - C. Leads in true position within 0.010 (0,25) R @ MMC at seating plane.
 - D. Pin numbers shown for reference only. Numbers may not be marked on package.
 - E. Falls within JEDEC MO-002/TO-99.

重要声明和免责声明

TI“按原样”提供技术和可靠性数据（包括数据表）、设计资源（包括参考设计）、应用或其他设计建议、网络工具、安全信息和其他资源，不保证没有瑕疵且不做任何明示或暗示的担保，包括但不限于对适销性、某特定用途方面的适用性或不侵犯任何第三方知识产权的暗示担保。

这些资源可供使用 TI 产品进行设计的熟练开发人员使用。您将自行承担以下全部责任：(1) 针对您的应用选择合适的 TI 产品，(2) 设计、验证并测试您的应用，(3) 确保您的应用满足相应标准以及任何其他功能安全、信息安全、监管或其他要求。

这些资源如有变更，恕不另行通知。TI 授权您仅可将这些资源用于研发本资源所述的 TI 产品的应用。严禁对这些资源进行其他复制或展示。您无权使用任何其他 TI 知识产权或任何第三方知识产权。您应全额赔偿因在这些资源的使用中对 TI 及其代表造成的任何索赔、损害、成本、损失和债务，TI 对此概不负责。

TI 提供的产品受 [TI 的销售条款](#) 或 [ti.com](#) 上其他适用条款/TI 产品随附的其他适用条款的约束。TI 提供这些资源并不会扩展或以其他方式更改 TI 针对 TI 产品发布的适用的担保或担保免责声明。

TI 反对并拒绝您可能提出的任何其他或不同的条款。

邮寄地址：Texas Instruments, Post Office Box 655303, Dallas, Texas 75265

Copyright © 2022，德州仪器 (TI) 公司