

LM79LXXAC Series 3-Terminal Negative Regulators

Check for Samples: [LM79L05](#), [LM79L12](#), [LM79L12AC](#), [LM79L15](#), [LM79L15AC](#)

FEATURES

- Preset Output Voltage Error is Less than $\pm 5\%$ Over Load, Line and Temperature
- Specified at an Output Current of 100mA
- Easily Compensated with a Small 0.1 μ F Output Capacitor
- Internal Short-Circuit, Thermal and Safe Operating Area Protection
- Easily Adjustable to Higher Output Voltages
- Maximum Line Regulation Less than 0.07% V_{OUT}/V
- Maximum Load Regulation Less than 0.01% V_{OUT}/mA
- See AN-1112 (SNVA009) for DSBGA Considerations

DESCRIPTION

The LM79LXXAC series of 3-terminal negative voltage regulators features fixed output voltages of $-5V$, $-12V$, and $-15V$ with output current capabilities in excess of 100mA. These devices were designed using the latest computer techniques for optimizing the packaged IC thermal/electrical performance. The LM79LXXAC series, when combined with a minimum output capacitor of 0.1 μ F, exhibits an excellent transient response, a maximum line regulation of 0.07% V_O/V , and a maximum load regulation of 0.01% V_O/mA .

The LM79LXXAC series also includes, as self-protection circuitry: safe operating area circuitry for output transistor power dissipation limiting, a temperature independent short circuit current limit for peak output current limiting, and a thermal shutdown circuit to prevent excessive junction temperature. Although designed primarily as fixed voltage regulators, these devices may be combined with simple external circuitry for boosted and/or adjustable voltages and currents. The LM79LXXAC series is available in the 3-lead TO package, the 8-lead SOIC package, and the 6-Bump DSBGA package.

For output voltages other than the pre-set $-5V$, $-12V$ and $-15V$, the LM137L series provides an adjustable output voltage range from $-1.2V$ to $-47V$.

Typical Applications

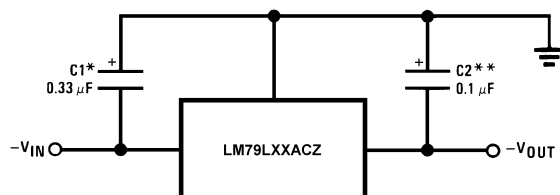

*Required if the regulator is located far from the power supply filter. A 1 μ F aluminum electrolytic may be substituted.
**Required for stability. A 1 μ F aluminum electrolytic may be substituted.

Figure 1. Fixed Output Regulator

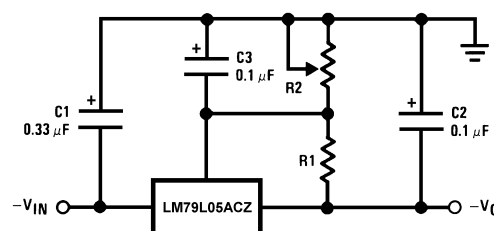

$$-V_0 = -5V - (5V/R1 + I_Q) \cdot R2,$$

$$5V/R1 > 3 I_Q$$

Figure 2. Adjustable Output Regulator



Please be aware that an important notice concerning availability, standard warranty, and use in critical applications of Texas Instruments semiconductor products and disclaimers thereto appears at the end of this data sheet.

All trademarks are the property of their respective owners.

LM79L05, LM79L12, LM79L12AC
LM79L15, LM79L15AC

SNOSBR8K – JULY 1999 – REVISED APRIL 2013

www.ti.com



These devices have limited built-in ESD protection. The leads should be shorted together or the device placed in conductive foam during storage or handling to prevent electrostatic damage to the MOS gates.

Connection Diagram

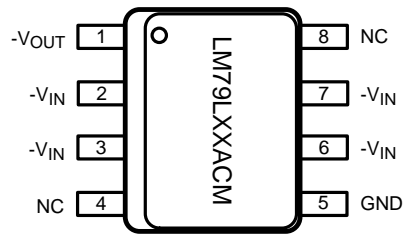

Pins labeled 'NC' on LM79LXXACM 8-Lead SOIC (pin 4 and pin 8) are Open, no internal connection.

**Figure 3. 8-Lead SOIC Narrow (D)
Top View**

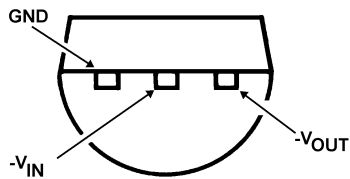

**Figure 4. 3-Lead TO-226 (LP)
Bottom View**

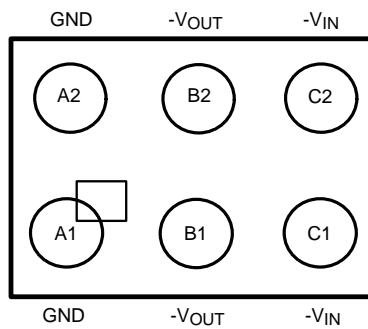

**Figure 5. 6-Bump DSBGA
Top View (Bump Side Down)**

Absolute Maximum Ratings⁽¹⁾⁽²⁾

Input Voltage	
$V_O = -5V, -12V, -15V$	-35V
Internal Power Dissipation ⁽³⁾	Internally Limited
Operating Temperature Range	0°C to +70°C
Maximum Junction Temperature	+125°C
Storage Temperature Range	-55°C to +150°C
Lead Temperature	
(Soldering, 10 sec.)	260°C

- (1) Absolute Maximum Ratings indicate limits beyond which damage to the device may occur. Operating Ratings indicate conditions for which the device is functional.
- (2) If Military/Aerospace specified devices are required, please contact the Texas Instruments Sales Office/Distributors for availability and specifications.
- (3) Thermal resistance of TO-226 (LP) package is 60°C/W θ_{JC} , 232°C/W θ_{JA} at still air, and 88°C/W at 400 ft/min of air. The θ_{JA} of the LM78LXX in the 6-Bump DSBGA package is 114°C/W when mounted on a 4-Layer JEDEC test board (JESD 51-7). The θ_{JA} of the LM78LXX in the SOIC-8 (D) package is 180°C/W in still air. The maximum junction temperature shall not exceed 125°C on electrical parameters.

Electrical Characteristics⁽¹⁾
 $T_A = 0^\circ\text{C}$ to $+70^\circ\text{C}$ unless otherwise noted.

Output Voltage			-5V			-12V			-15V			
Input Voltage (unless otherwise noted)			-10V			-17V			-20V			
Symbol	Parameter	Conditions	Min	Typ	Max	Min	Typ	Max	Min	Typ	Max	Units
V_O	Output Voltage	$T_J = 25^\circ\text{C}, I_O = 100\text{mA}$	-5.2	-5	-4.8	-12.5	-12	-11.5	-15.6	-15	-14.4	V
		$1\text{mA} \leq I_O \leq 100\text{mA}$	-5.25		-4.75	-12.6		-11.4	-15.7		-14.25	
		$V_{MIN} \leq V_{IN} \leq V_{MAX}$	(-20 $\leq V_{IN} \leq -7.5$)			(-27 $\leq V_{IN} \leq -14.8$)			(-30 $\leq V_{IN} \leq -18$)			
		$1\text{mA} \leq I_O \leq 40\text{mA}$	-5.25		-4.75	-12.6		-11.4	-15.7		-14.25	
		$V_{MIN} \leq V_{IN} \leq V_{MAX}$	(-20 $\leq V_{IN} \leq -7$)			(-27 $\leq V_{IN} \leq -14.5$)			(-30 $\leq V_{IN} \leq -17.5$)			
ΔV_O	Line Regulation	$T_J = 25^\circ\text{C}, I_O = 100\text{mA}$			60			45			45	mV
		$V_{MIN} \leq V_{IN} \leq V_{MAX}$	(-20 $\leq V_{IN} \leq -7.3$)			(-27 $\leq V_{IN} \leq -14.6$)			(-30 $\leq V_{IN} \leq -17.7$)			V
		$T_J = 25^\circ\text{C}, I_O = 40\text{mA}$			60			45			45	mV
		$V_{MIN} \leq V_{IN} \leq V_{MAX}$	(-20 $\leq V_{IN} \leq -7$)			(-27 $\leq V_{IN} \leq -14.5$)			(-30 $\leq V_{IN} \leq -17.5$)			V
ΔV_O	Load Regulation	$T_J = 25^\circ\text{C}$			50			100			125	mV
		$1\text{mA} \leq I_O \leq 100\text{mA}$										
ΔV_O	Long Term Stability	$I_O = 100\text{mA}$		20			48			60		mV/khrs
I_Q	Quiescent Current	$I_O = 100\text{mA}$		2	6		2	6		2	6	mA
ΔI_Q	Quiescent Current Change	$1\text{mA} \leq I_O \leq 100\text{mA}$			0.3			0.3			0.3	mA
		$1\text{mA} \leq I_O \leq 40\text{mA}$			0.1			0.1			0.1	
		$I_O = 100\text{mA}$			0.25			0.25			0.25	mA
		$V_{MIN} \leq V_{IN} \leq V_{MAX}$	(-20 $\leq V_{IN} \leq -7.5$)			(-27 $\leq V_{IN} \leq -14.8$)			(-30 $\leq V_{IN} \leq -18$)			V
V_n	Output Noise Voltage	$T_J = 25^\circ\text{C}, I_O = 100\text{mA}$ $f = 10\text{Hz} - 10\text{kHz}$		40			96			120		μV
$\Delta V_{IN}/\Delta V_O$	Ripple Rejection	$T_J = 25^\circ\text{C}, I_O = 100\text{mA}$ $f = 120\text{Hz}$	50			52			50			dB
	Input Voltage Required to Maintain Line Regulation	$T_J = 25^\circ\text{C}, I_O = 100\text{mA}$			-7.3			-14.6			-17.7	V
		$I_O = 40\text{mA}$			-7.0			-14.5			-17.5	V

- (1) To ensure constant junction temperature, low duty cycle pulse testing is used.

Typical Performance Characteristics

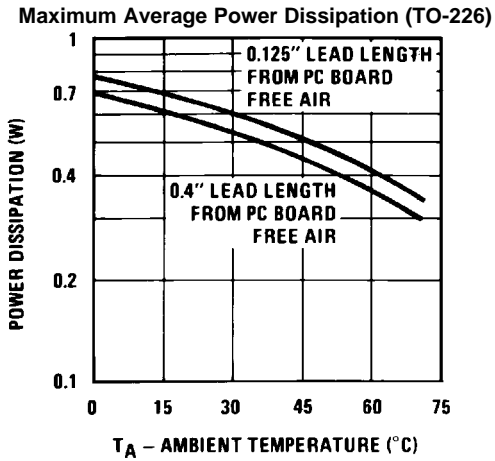

Figure 6.

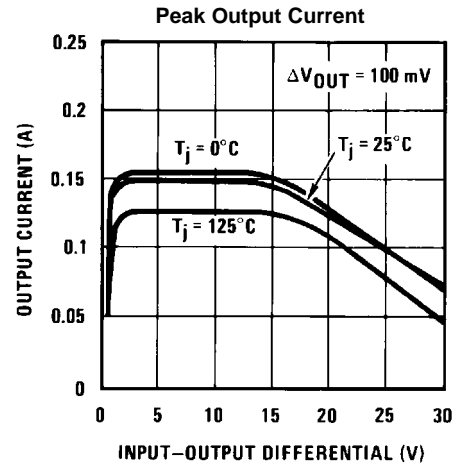

Figure 7.

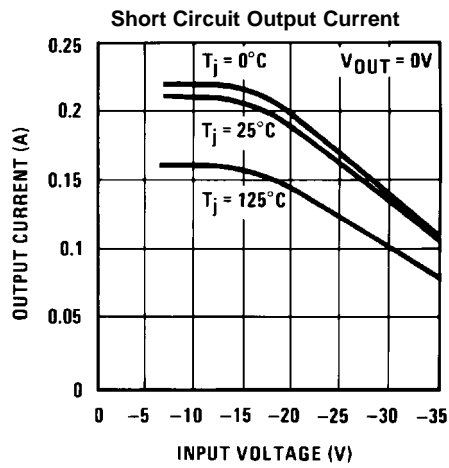

Figure 8.

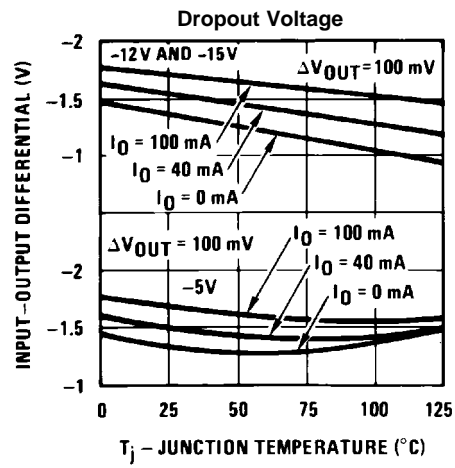

Figure 9.

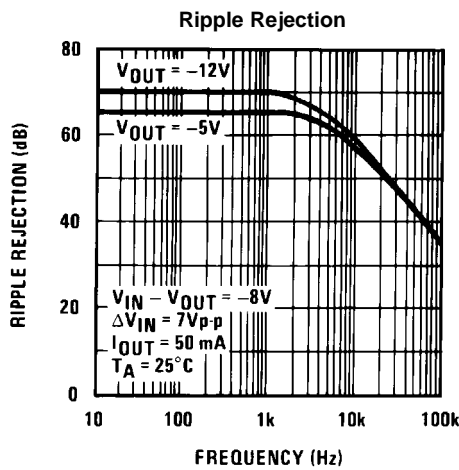

Figure 10.

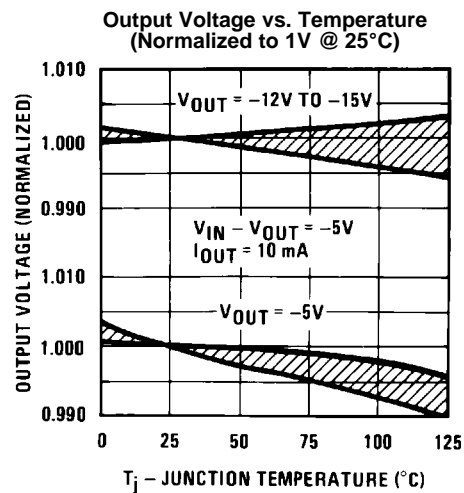
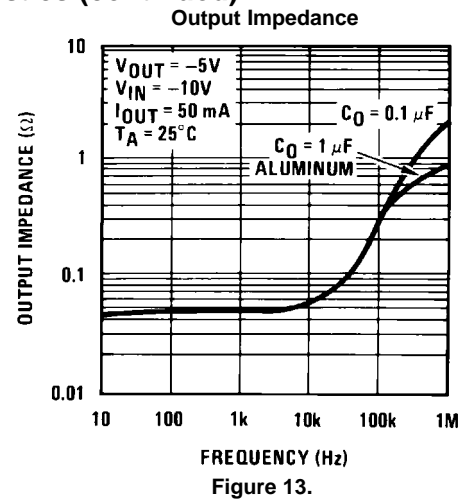
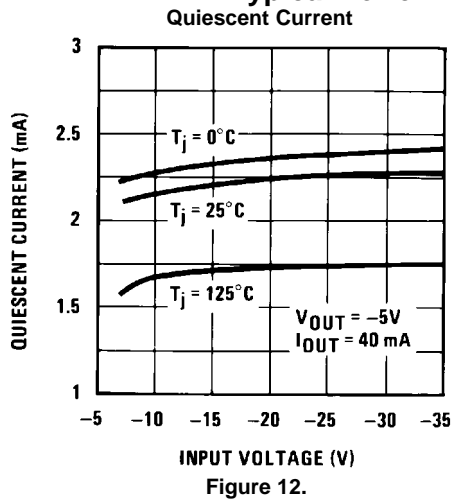

Figure 11.

Typical Performance Characteristics (continued)



TYPICAL APPLICATIONS

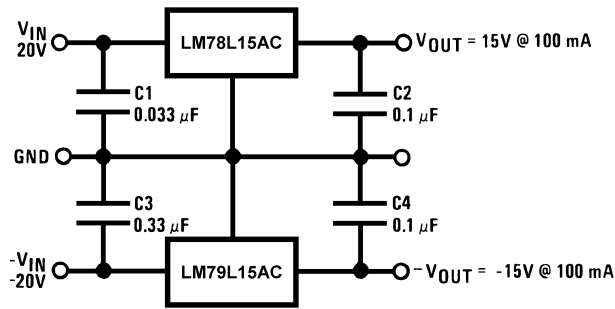

Figure 14. ±15V, 100mA Dual Power Supply

Schematic Diagrams

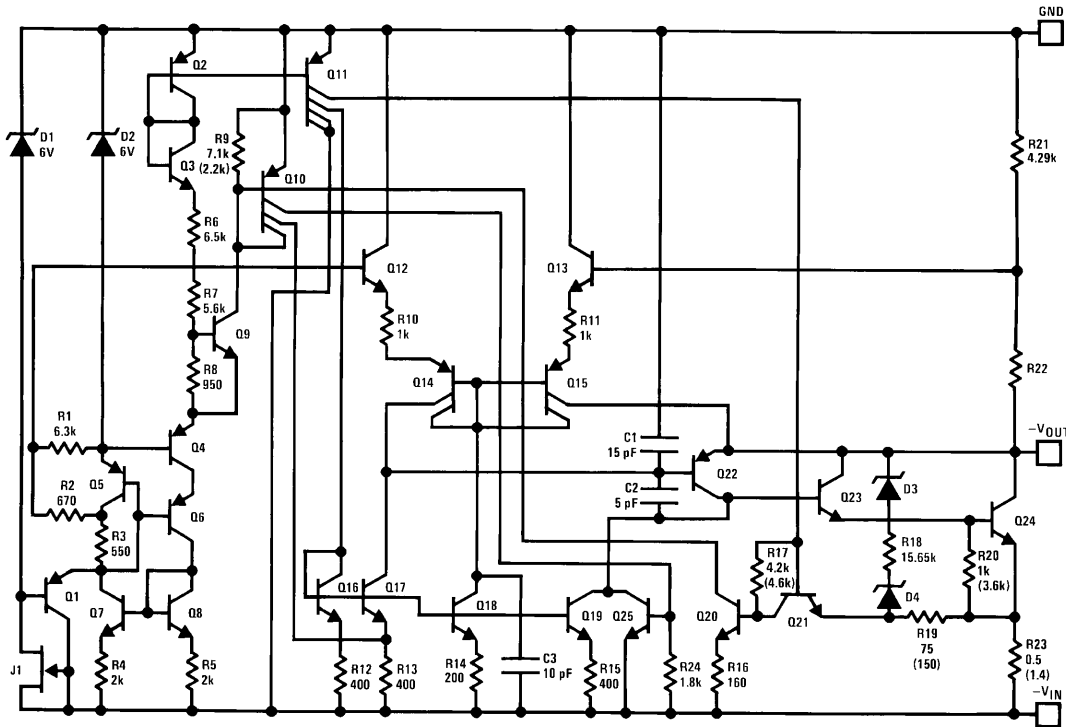

Figure 15. -5V Schematic Diagram

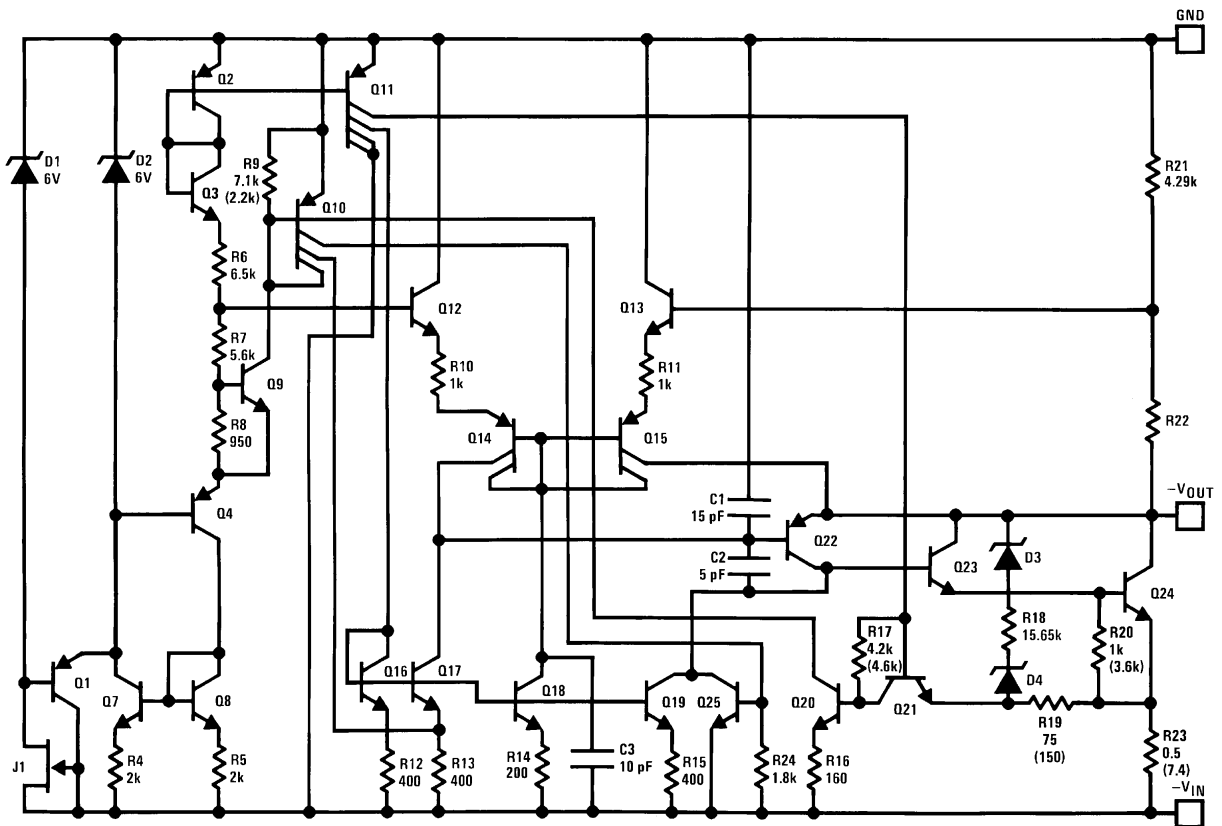

Figure 16. -12V and -15V Schematic Diagram

**LM79L05, LM79L12, LM79L12AC
LM79L15, LM79L15AC**

SNOSBR8K – JULY 1999 – REVISED APRIL 2013

www.ti.com

REVISION HISTORY

Changes from Revision J (April 2013) to Revision K	Page
<ul style="list-style-type: none"> Changed layout of National Data Sheet to TI format 	7

PACKAGING INFORMATION

Orderable Device	Status (1)	Package Type	Package Drawing	Pins	Package Qty	Eco Plan (2)	Lead finish/ Ball material (6)	MSL Peak Temp (3)	Op Temp (°C)	Device Marking (4/5)	Samples
LM79L05ACM	NRND	SOIC	D	8	95	Non-RoHS & Green	Call TI	Level-1-235C-UNLIM	0 to 70	LM79L05ACM	
LM79L05ACM/NOPB	ACTIVE	SOIC	D	8	95	RoHS & Green	SN	Level-1-260C-UNLIM	0 to 70	LM79L05ACM	Samples
LM79L05ACMX/NOPB	ACTIVE	SOIC	D	8	2500	RoHS & Green	SN	Level-1-260C-UNLIM	0 to 70	LM79L05ACM	Samples
LM79L05ACTL/NOPB	ACTIVE	DSBGA	YZR	6	250	RoHS & Green	SNAGCU	Level-1-260C-UNLIM	0 to 70	P B	Samples
LM79L05ACTLX/NOPB	ACTIVE	DSBGA	YZR	6	3000	RoHS & Green	SNAGCU	Level-1-260C-UNLIM	0 to 70	P B	Samples
LM79L05ACZ/LFT1	ACTIVE	TO-92	LP	3	2000	RoHS & Green	SN	N / A for Pkg Type		320L 79L05	Samples
LM79L05ACZ/NOPB	ACTIVE	TO-92	LP	3	1800	RoHS & Green	SN	N / A for Pkg Type	0 to 70	320L 79L05	Samples
LM79L12ACM	NRND	SOIC	D	8	95	Non-RoHS & Green	Call TI	Level-1-235C-UNLIM	0 to 70	LM79L12ACM	
LM79L12ACM/NOPB	ACTIVE	SOIC	D	8	95	RoHS & Green	SN	Level-1-260C-UNLIM	0 to 70	LM79L12ACM	Samples
LM79L12ACMX/NOPB	ACTIVE	SOIC	D	8	2500	RoHS & Green	SN	Level-1-260C-UNLIM	0 to 70	LM79L12ACM	Samples
LM79L12ACZ/LFT4	ACTIVE	TO-92	LP	3	2000	RoHS & Green	SN	N / A for Pkg Type		320L 79L12	Samples
LM79L12ACZ/NOPB	ACTIVE	TO-92	LP	3	1800	RoHS & Green	SN	N / A for Pkg Type	0 to 70	320L 79L12	Samples
LM79L15ACM	NRND	SOIC	D	8	95	Non-RoHS & Green	Call TI	Level-1-235C-UNLIM	0 to 70	LM79L15ACM	
LM79L15ACM/NOPB	ACTIVE	SOIC	D	8	95	RoHS & Green	SN	Level-1-260C-UNLIM	0 to 70	LM79L15ACM	Samples
LM79L15ACMX/NOPB	ACTIVE	SOIC	D	8	2500	RoHS & Green	SN	Level-1-260C-UNLIM	0 to 70	LM79L15ACM	Samples

(1) The marketing status values are defined as follows:

ACTIVE: Product device recommended for new designs.

LIFEBUY: TI has announced that the device will be discontinued, and a lifetime-buy period is in effect.

NRND: Not recommended for new designs. Device is in production to support existing customers, but TI does not recommend using this part in a new design.

PREVIEW: Device has been announced but is not in production. Samples may or may not be available.

OBSOLETE: TI has discontinued the production of the device.

⁽²⁾ **RoHS:** TI defines "RoHS" to mean semiconductor products that are compliant with the current EU RoHS requirements for all 10 RoHS substances, including the requirement that RoHS substance do not exceed 0.1% by weight in homogeneous materials. Where designed to be soldered at high temperatures, "RoHS" products are suitable for use in specified lead-free processes. TI may reference these types of products as "Pb-Free".

RoHS Exempt: TI defines "RoHS Exempt" to mean products that contain lead but are compliant with EU RoHS pursuant to a specific EU RoHS exemption.

Green: TI defines "Green" to mean the content of Chlorine (Cl) and Bromine (Br) based flame retardants meet JS709B low halogen requirements of <=1000ppm threshold. Antimony trioxide based flame retardants must also meet the <=1000ppm threshold requirement.

⁽³⁾ **MSL, Peak Temp.** - The Moisture Sensitivity Level rating according to the JEDEC industry standard classifications, and peak solder temperature.

⁽⁴⁾ There may be additional marking, which relates to the logo, the lot trace code information, or the environmental category on the device.

⁽⁵⁾ Multiple Device Markings will be inside parentheses. Only one Device Marking contained in parentheses and separated by a "~" will appear on a device. If a line is indented then it is a continuation of the previous line and the two combined represent the entire Device Marking for that device.

⁽⁶⁾ **Lead finish/Ball material** - Orderable Devices may have multiple material finish options. Finish options are separated by a vertical ruled line. Lead finish/Ball material values may wrap to two lines if the finish value exceeds the maximum column width.

Important Information and Disclaimer:The information provided on this page represents TI's knowledge and belief as of the date that it is provided. TI bases its knowledge and belief on information provided by third parties, and makes no representation or warranty as to the accuracy of such information. Efforts are underway to better integrate information from third parties. TI has taken and continues to take reasonable steps to provide representative and accurate information but may not have conducted destructive testing or chemical analysis on incoming materials and chemicals. TI and TI suppliers consider certain information to be proprietary, and thus CAS numbers and other limited information may not be available for release.

In no event shall TI's liability arising out of such information exceed the total purchase price of the TI part(s) at issue in this document sold by TI to Customer on an annual basis.

TAPE AND REEL INFORMATION

QUADRANT ASSIGNMENTS FOR PIN 1 ORIENTATION IN TAPE

*All dimensions are nominal

Device	Package Type	Package Drawing	Pins	SPQ	Reel Diameter (mm)	Reel Width W1 (mm)	A0 (mm)	B0 (mm)	K0 (mm)	P1 (mm)	W (mm)	Pin1 Quadrant
LM79L05ACMX/NOPB	SOIC	D	8	2500	330.0	12.4	6.5	5.4	2.0	8.0	12.0	Q1
LM79L05ACTL/NOPB	DSBGA	YZR	6	250	178.0	8.4	1.09	1.88	0.76	4.0	8.0	Q1
LM79L05ACTLX/NOPB	DSBGA	YZR	6	3000	178.0	8.4	1.09	1.88	0.76	4.0	8.0	Q1
LM79L12ACMX/NOPB	SOIC	D	8	2500	330.0	12.4	6.5	5.4	2.0	8.0	12.0	Q1
LM79L15ACMX/NOPB	SOIC	D	8	2500	330.0	12.4	6.5	5.4	2.0	8.0	12.0	Q1

TAPE AND REEL BOX DIMENSIONS

*All dimensions are nominal

Device	Package Type	Package Drawing	Pins	SPQ	Length (mm)	Width (mm)	Height (mm)
LM79L05ACMX/NOPB	SOIC	D	8	2500	367.0	367.0	35.0
LM79L05ACTL/NOPB	DSBGA	YZR	6	250	208.0	191.0	35.0
LM79L05ACTLX/NOPB	DSBGA	YZR	6	3000	208.0	191.0	35.0
LM79L12ACMX/NOPB	SOIC	D	8	2500	367.0	367.0	35.0
LM79L15ACMX/NOPB	SOIC	D	8	2500	367.0	367.0	35.0

TUBE

*All dimensions are nominal

Device	Package Name	Package Type	Pins	SPQ	L (mm)	W (mm)	T (μm)	B (mm)
LM79L05ACM	D	SOIC	8	95	495	8	4064	3.05
LM79L05ACM	D	SOIC	8	95	495	8	4064	3.05
LM79L05ACM/NOPB	D	SOIC	8	95	495	8	4064	3.05
LM79L12ACM	D	SOIC	8	95	495	8	4064	3.05
LM79L12ACM	D	SOIC	8	95	495	8	4064	3.05
LM79L12ACM/NOPB	D	SOIC	8	95	495	8	4064	3.05
LM79L15ACM	D	SOIC	8	95	495	8	4064	3.05
LM79L15ACM	D	SOIC	8	95	495	8	4064	3.05
LM79L15ACM/NOPB	D	SOIC	8	95	495	8	4064	3.05



D0008A

PACKAGE OUTLINE

SOIC - 1.75 mm max height

SMALL OUTLINE INTEGRATED CIRCUIT

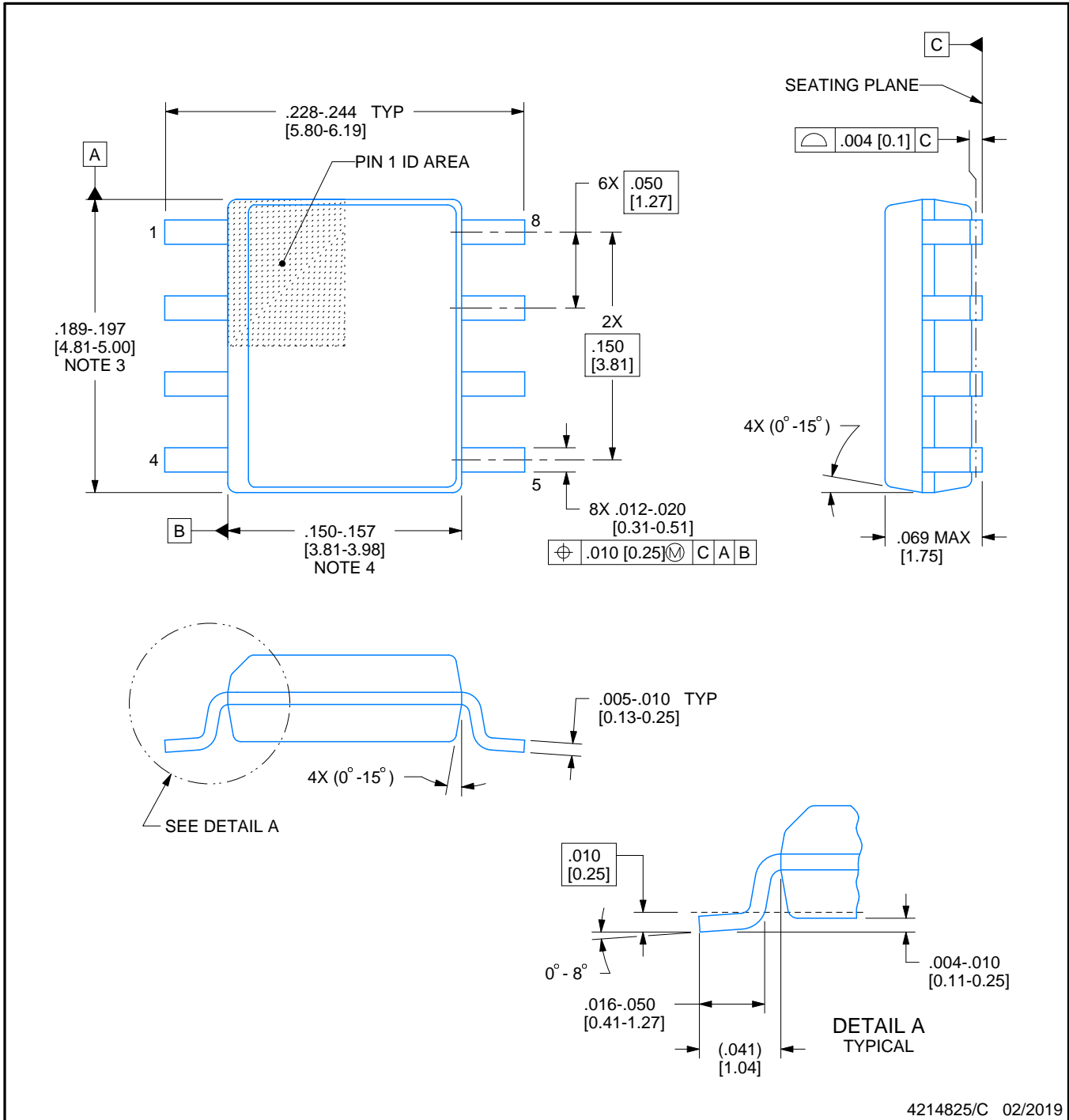

4214825/C 02/2019

NOTES:

1. Linear dimensions are in inches [millimeters]. Dimensions in parenthesis are for reference only. Controlling dimensions are in inches. Dimensioning and tolerancing per ASME Y14.5M.
2. This drawing is subject to change without notice.
3. This dimension does not include mold flash, protrusions, or gate burrs. Mold flash, protrusions, or gate burrs shall not exceed $.006$ [0.15] per side.
4. This dimension does not include interlead flash.
5. Reference JEDEC registration MS-012, variation AA.

EXAMPLE BOARD LAYOUT

D0008A

SOIC - 1.75 mm max height

SMALL OUTLINE INTEGRATED CIRCUIT

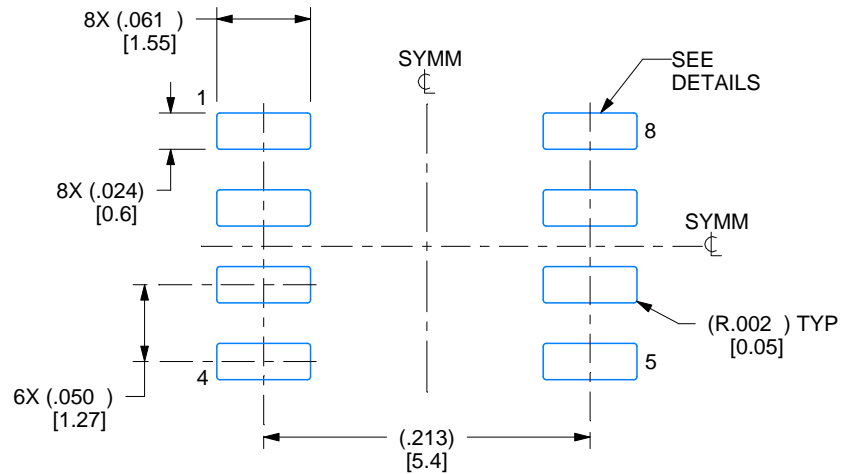

LAND PATTERN EXAMPLE
EXPOSED METAL SHOWN
SCALE:8X

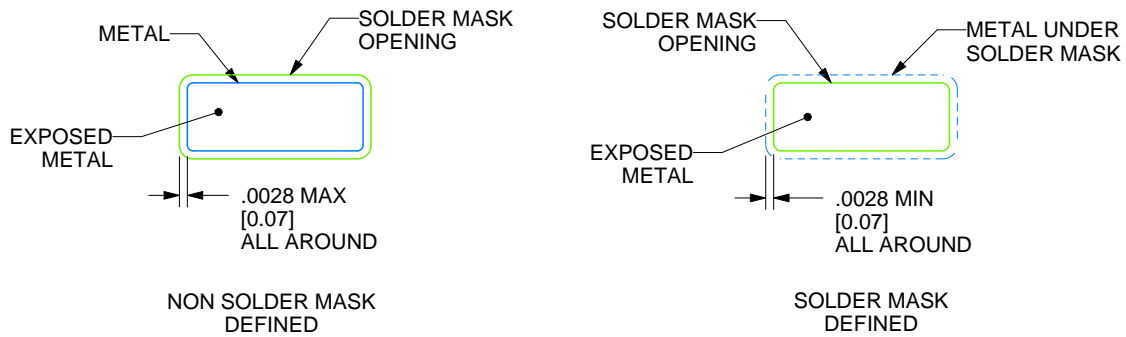

SOLDER MASK DETAILS

4214825/C 02/2019

NOTES: (continued)

6. Publication IPC-7351 may have alternate designs.

7. Solder mask tolerances between and around signal pads can vary based on board fabrication site.

EXAMPLE STENCIL DESIGN

D0008A

SOIC - 1.75 mm max height

SMALL OUTLINE INTEGRATED CIRCUIT



SOLDER PASTE EXAMPLE
BASED ON .005 INCH [0.125 MM] THICK STENCIL
SCALE:8X

4214825/C 02/2019

NOTES: (continued)

8. Laser cutting apertures with trapezoidal walls and rounded corners may offer better paste release. IPC-7525 may have alternate design recommendations.
9. Board assembly site may have different recommendations for stencil design.

GENERIC PACKAGE VIEW

LP 3

TO-92 - 5.34 mm max height

TRANSISTOR OUTLINE



Images above are just a representation of the package family, actual package may vary.
Refer to the product data sheet for package details.

4040001-2/F

LP0003A



PACKAGE OUTLINE

TO-92 - 5.34 mm max height

TO-92

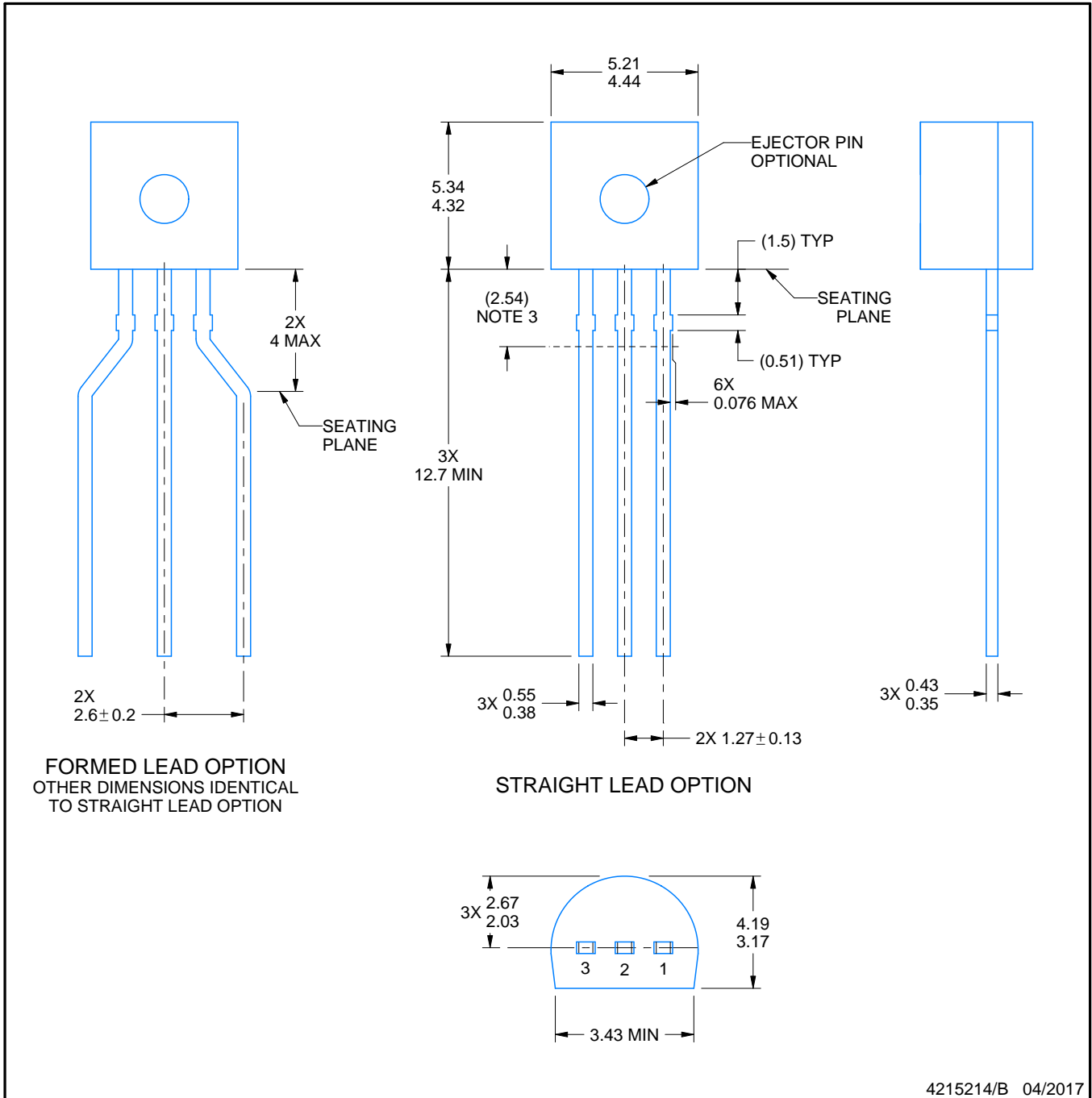

4215214/B 04/2017

NOTES:

1. All linear dimensions are in millimeters. Any dimensions in parenthesis are for reference only. Dimensioning and tolerancing per ASME Y14.5M.
2. This drawing is subject to change without notice.
3. Lead dimensions are not controlled within this area.
4. Reference JEDEC TO-226, variation AA.
5. Shipping method:
 - a. Straight lead option available in bulk pack only.
 - b. Formed lead option available in tape and reel or ammo pack.
 - c. Specific products can be offered in limited combinations of shipping medium and lead options.
 - d. Consult product folder for more information on available options.

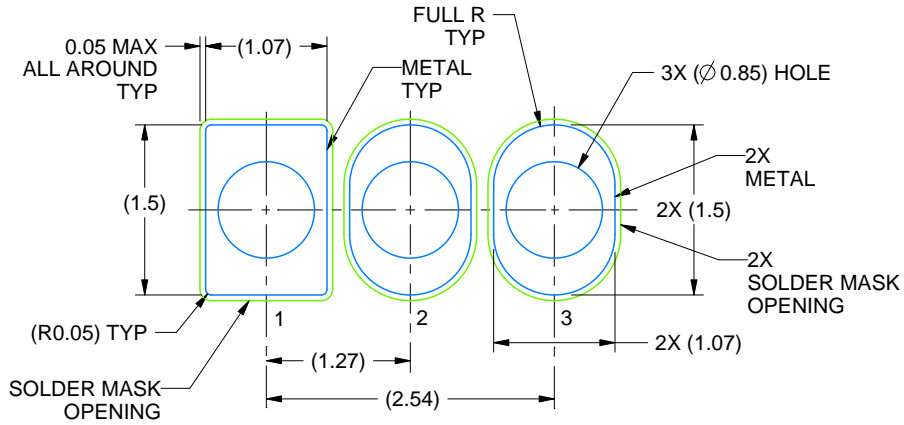

LAND PATTERN EXAMPLE
STRAIGHT LEAD OPTION
NON-SOLDER MASK DEFINED
SCALE:15X

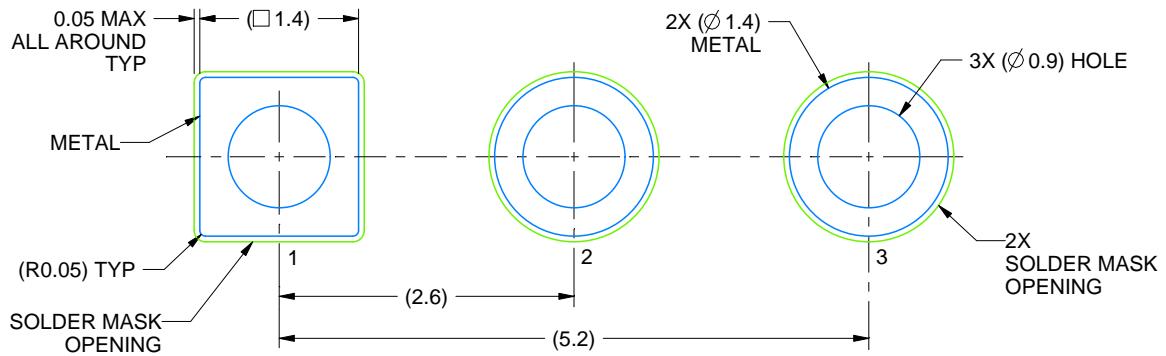

LAND PATTERN EXAMPLE
FORMED LEAD OPTION
NON-SOLDER MASK DEFINED
SCALE:15X

TAPE SPECIFICATIONS

LP0003A

TO-92 - 5.34 mm max height

TO-92

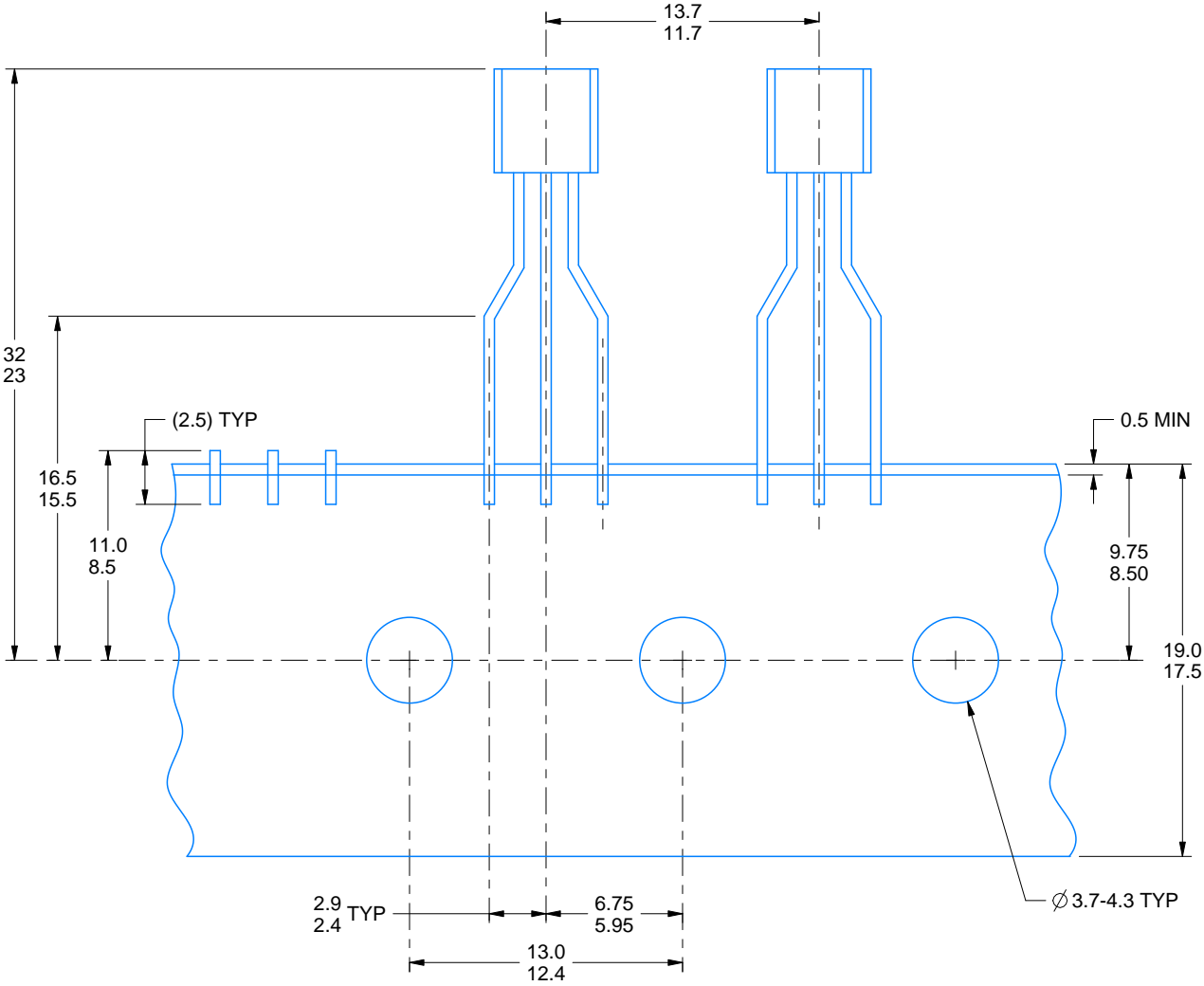

FOR FORMED LEAD OPTION PACKAGE

4215214/B 04/2017

IMPORTANT NOTICE AND DISCLAIMER

TI PROVIDES TECHNICAL AND RELIABILITY DATA (INCLUDING DATA SHEETS), DESIGN RESOURCES (INCLUDING REFERENCE DESIGNS), APPLICATION OR OTHER DESIGN ADVICE, WEB TOOLS, SAFETY INFORMATION, AND OTHER RESOURCES "AS IS" AND WITH ALL FAULTS, AND DISCLAIMS ALL WARRANTIES, EXPRESS AND IMPLIED, INCLUDING WITHOUT LIMITATION ANY IMPLIED WARRANTIES OF MERCHANTABILITY, FITNESS FOR A PARTICULAR PURPOSE OR NON-INFRINGEMENT OF THIRD PARTY INTELLECTUAL PROPERTY RIGHTS.

These resources are intended for skilled developers designing with TI products. You are solely responsible for (1) selecting the appropriate TI products for your application, (2) designing, validating and testing your application, and (3) ensuring your application meets applicable standards, and any other safety, security, regulatory or other requirements.

These resources are subject to change without notice. TI grants you permission to use these resources only for development of an application that uses the TI products described in the resource. Other reproduction and display of these resources is prohibited. No license is granted to any other TI intellectual property right or to any third party intellectual property right. TI disclaims responsibility for, and you will fully indemnify TI and its representatives against, any claims, damages, costs, losses, and liabilities arising out of your use of these resources.

TI's products are provided subject to [TI's Terms of Sale](#) or other applicable terms available either on ti.com or provided in conjunction with such TI products. TI's provision of these resources does not expand or otherwise alter TI's applicable warranties or warranty disclaimers for TI products.

TI objects to and rejects any additional or different terms you may have proposed.

Mailing Address: Texas Instruments, Post Office Box 655303, Dallas, Texas 75265
Copyright © 2022, Texas Instruments Incorporated