

LM8330 I²C-Compatible Keypad Controller with GPIO, PWM, and IEC61000 ESD Protection

Check for Samples: [LM8330](#)

FEATURES

• KEY FEATURES

- Keypad Matrices of up to of 8 x 12 Keys, Plus 8 Special Function (SF) Keys, for a Full 104 Key Support.
- Supports General-purpose I/O Expansion on Pins Not Otherwise Used for Keypad or PWM Output.
- Keypad Matrix and Dedicated Key Support:
 - 16-Event Keycode Buffer
 - 4-Event Multiple Key Storage Registers
- Internal Oscillator, No External Clock Required.
- I²C-compatible ACCESS.bus Slave Interface Standard (100 kHz) and Fast (400 kHz) Modes:
 - 7-bit and 10-bit Addressing
 - Programmable Slave Address
 - (Default 7-bit 0x88, 10-bit 0x088)
- Three Host-programmable PWM Outputs
 - Smooth LED Brightness Modulation
 - Dedicated 31-command Script Bugger
 - Register-based Command Interpreter with Auto-increment Addressing
- Key Events, Errors, and Dedicated Hardware Interrupts, Request Host Service by Asserting an IRQ Output
- Ultra-Low-Power Operation
 - Automatic HALT Mode: 1.5 μ A (typ.)
 - Active Supply Current: 23 μ A (typ.)
 - Configurable Wake-Up from HALT Operation
- IEC61000-4-2 ESD Protection on KPX[7:0] and KPY[10:0] pins
- ESD Glitch Filter on RESETN Input
- External Reset for System Control

• HOST-CONTROLLED FEATURES

- Reset Input for System Control
- PWM Scripting for Three PWM Outputs
- Period of Inactivity That Triggers Entry into HALT Mode

- Debounce Time for Reliable Key Event Polling
 - Configuration of General Purpose I/O Ports
 - Various Initialization Options (Keypad Size, etc.)
- ### • KEY DEVICE FEATURES
- 1.8V \pm 10% Single-supply Operation
 - On-chip Power-on Reset (POR)
 - -30°C to $+85^{\circ}\text{C}$ Temperature Range
 - Robust IEC ESD Protection: \pm 8 kV Direct Contact on KPX[7:0] and KPY[10:0] Pins
 - 25-pin DSBGA Package Size: 2 mm x 2 mm x 0.6 mm (0.4 mm Pitch)

APPLICATIONS:

- Mobile Phones
- Qwerty Keyboard
- Universal Remote

DESCRIPTION

The LM8330 I/O - Expander and Keypad Controller is a dedicated device designed to unburden a host processor from scanning a matrix-addressed keypad and to provide flexible and general purpose, host programmable input/output functions. Three independent Pulse Width Modulation (PWM) timer outputs are provided for dynamic LED brightness modulation.

It communicates with a host processor through an I²C-compatible ACCESS.bus serial interface. It can communicate in Standard (100 kHz) and Fast-Mode (400 kHz) in slave Mode only.

All available input/output pins can alternately be used as an input or an output in a keypad matrix or as a host-programmable general-purpose input or output.

Any pin programmed as an input can also sense hardware interrupts. The interrupt polarity (“high-to-low” or “low-to-high” transition) is thereby programmable.

The LM8330 follows a predefined register-based set of commands. Upon startup (power-on) a configuration file must be sent from the host to set up the hardware of the device.



Please be aware that an important notice concerning availability, standard warranty, and use in critical applications of Texas Instruments semiconductor products and disclaimers thereto appears at the end of this data sheet.

All trademarks are the property of their respective owners.

DESCRIPTION (CONTINUED)

The LM8330 is available in a 25-bump lead-free DSBGA package size 2.0 mm x 2.0 mm x 0.6 mm (0.4 mm pitch).

The LM8330 has integrated ASIP (Application Specific Integrated Passives) on the KPX[7:0] and KPY[10:0] pins. These pins are designed to tolerate IEC61000-4-2 level 4 ESD: ±8 kV direct contact.

LM8330 FUNCTION BLOCKS

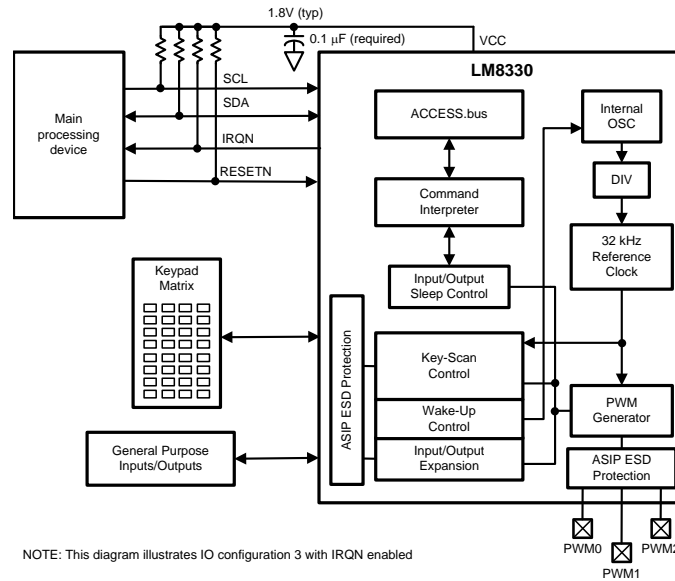

PACKAGE MARKING

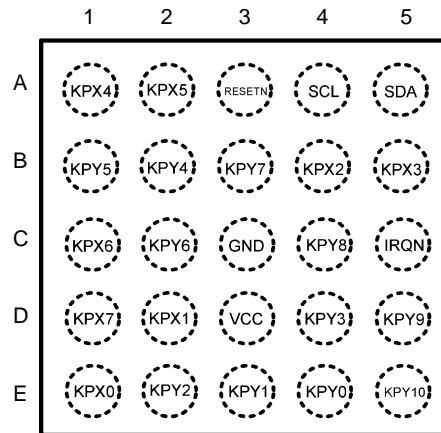

Figure 1. LM8330 Pinout - Top View (balls underneath)

SIGNAL DESCRIPTIONS
Primary and Alternate Functions of All Device Pins

Ball	Function 0 ⁽¹⁾	Function 1 ⁽¹⁾	Function 2 ⁽¹⁾	Function 3 ⁽¹⁾	Pin Count	Ball Name
A3	Reset Active Low Input				1	RESETN
D3	Supply Voltage				1	VCC
A4	ACCESS.bus Clock				1	SCL
A5	ACCESS.bus Data				1	SDA
E1	Keypad-I/O X0	GPIO0			1	KPX0
D2	Keypad-I/O X1	GPIO1			1	KPX1
B4	Keypad-I/O X2	GPIO2			1	KPX2
B5	Keypad-I/O X3	GPIO3			1	KPX3
A1	Keypad-I/O X4	GPIO4			1	KPX4
A2	Keypad-I/O X5	GPIO5			1	KPX5
C1	Keypad-I/O X6	GPIO6			1	KPX6
D1	Keypad-I/O X7	GPIO7			1	KPX7
E4	Keypad-I/O Y0	GPIO8			1	KPY0
E3	Keypad-I/O Y1	GPIO9			1	KPY1
E2	Keypad-I/O Y2	GPIO10			1	KPY2
D4	Keypad-I/O Y3	GPIO11			1	KPY3
B2	Keypad-I/O Y4	GPIO12			1	KPY4
B1	Keypad-I/O Y5	GPIO13			1	KPY5
C2	Keypad-I/O Y6	GPIO14			1	KPY6
B3	Keypad-I/O Y7	GPIO15			1	KPY7
C4	Keypad-I/O Y8	GPIO16	PWM2 ⁽²⁾		1	KPY8
D5	Keypad-I/O Y9	GPIO17	PWM1		1	KPY9
E5	Keypad-I/O Y10	GPIO18	PWM0		1	KPY10
C5	Keypad-I/O Y11	GPIO19	PWM2 ⁽²⁾	Interrupt	1	IRQN
C3	Ground				1	GND
Total					25	

- (1) This table describes the alternate pin function and not the actual BALLCFG assignments. Refer to [Table 49](#) for actual BALLCFG Assignments.
- (2) PWM2 functionality is mutually exclusive - one pin at a time only (KPY8 or KPY11) depending on interrupt enable Bit 4 of IOCFG.



These devices have limited built-in ESD protection. The leads should be shorted together or the device placed in conductive foam during storage or handling to prevent electrostatic damage to the MOS gates.

ABSOLUTE MAXIMUM RATINGS ⁽¹⁾⁽²⁾

Supply Voltage (V_{CC})		-0.3V to 2.2V
Voltage at Generic I/Os		-0.2V to $V_{CC} + 0.2V$
Voltage at Backdrive I/Os		-0.3V to +2.2V
Junction Temperature		+150°C
Storage Temperature Range		-40°C to +140°C
Lead Temperature (T_L) (Soldering, 10 sec.)		+260°C
ESD Protection Level	Human Body Model:	2000V
	Machine Model:	200V
	Charge Device Model:	500V
IEC61000-4-2, 330Ω, 150 pF:	Direct Contact (ASIP I/O only):	±8kV

- (1) Absolute Maximum Ratings indicate limits beyond which damage to the device may occur. Operating Ratings indicate conditions for which the device is intended to be functional, but specific performance is not ensured. For ensured specifications and test conditions, see the Electrical Characteristics tables.
- (2) If Military/Aerospace specified devices are required, please contact the TI Sales Office/ Distributors for availability and specifications.

OPERATING RATINGS

	Min	Max	Units
VCC Supply Voltage	1.62	1.98	V
Supply Noise		50	mVpp
Operating Ambient Temperature	-30°C to +85°C		

DC ELECTRICAL CHARACTERISTICS

Datasheet min/max specification limits are specified by design, test, or statistical analysis. Temperature: $-30^{\circ}\text{C} \leq T_A \leq +85^{\circ}\text{C}$, $V_{CC} = 1.8V \pm 10\%$, unless otherwise specified

Symbol	Parameter	Conditions	Min	Typ	Max	Units
V_{CC}	Operating Voltage	Core Supply Voltage	1.62		1.98	V
ICC_{DYN1}	Supply Current ⁽¹⁾	No load on any Output pin, $V_{CC} = 1.8V$, $T_A = 25^{\circ}\text{C}$ Active 8x7 Keypad matrix, ACCESS.Bus frequency = 400 Khz, No key pressed, PWM Inactive		23	30	μA
ICC_{DYN2}		No load on any Output pin, $V_{CC} = 1.8V$, $T_A = 25^{\circ}\text{C}$ All GPIO Mode - outputs toggling, ACCESS.Bus frequency = 400 Khz, PWM Inactive		18	25	
ICC_{HALT}		Sleep Mode HALT Current ⁽²⁾	$V_{CC} = 1.8V$, $T_A = 25^{\circ}\text{C}$ Internal Clock = OFF, no internal functional blocks running		1.5	

- (1) Supply current is measured with inputs connected to V_{CC} and outputs driven low but not connected to a load.
- (2) In sleep mode, the internal clock is switched off. Supply current in sleep mode is measured with inputs connected to V_{CC} and outputs driven low but not connected to a load.

AC ELECTRICAL CHARACTERISTICS

Datasheet min/max specification limits are specified by design, test, or statistical analysis. Temperature: $-30^{\circ}\text{C} \leq T_A \leq +85^{\circ}\text{C}$, $V_{CC} = 1.8\text{V} \pm 10\%$, unless otherwise specified.

Symbol	Parameter	Conditions	Min	Typ	Max	Units
f_{OSC}	Internal Oscillator Frequency	$1.62\text{V} \leq V_{CC} \leq 1.98\text{V}$	51.2	64	76.8	KHz
t_{OSC}	Internal Oscillator Period			15.625		μS
ACCESS.bus Signal Timing						
f_{SCL}	ACCESS.bus Clock Frequency	$1.62\text{V} \leq V_{CC} \leq 1.98\text{V}$			400	KHz
t_{BUF}				1.3		
t_{CSTOsi}	SCL Setup Time	Before Stop Condition	0.6			
t_{SCLhigh}	SCL High Time	After SCL Rising Edge	0.6			
t_{SCLlow}	SCL Low Time	After SCL Falling Edge	1.0			
t_{CSTRhi}	SCL Hold Time	Repeated-Start Condition	0.6			
t_{DHC}	SDA Setup Time	Before SCL Rising Edge	0.1			
t_{SDAhi}	SDA Hold Time	After SCL Falling Edge	0.3			
RESETN Timing						
t_{SPIKE}	RST Input Glitch Filter ()	$0 < V_{\text{IN}} < V_{\text{DD}}$	50	100		nS

GENERAL GPIO DC CHARACTERISTICS

Characteristics for pins KPX[7:0], KPY[10:0]. Datasheet min/max specification limits are specified by design, test, or statistical analysis. Temperature: $-30^{\circ}\text{C} \leq T_A \leq +85^{\circ}\text{C}$, $V_{CC} = 1.8\text{V} \pm 10\%$, unless otherwise specified.

Symbol	Parameter	Conditions	Min	Typ	Max	Units
V_{IH}	Min. Input High Voltage		$0.65 \times V_{CC}$			V
V_{IL}	Max. Input Low Voltage				$0.35 \times V_{CC}$	
I_{Source}		$V_{CC} = 1.62$ $V_{\text{OH}} = 0.65 \times V_{CC}$			-4.5	mA
I_{Sink}		$V_{CC} = 1.62$ $V_{\text{OL}} = 0.35 \times V_{CC}$			4.5	mA
	Allowable Sink Current per pin ⁽¹⁾			6.5		mA
I_{PU}	Weak pullup Current	$V_{\text{OUT}} = 0\text{V}$	-160		-30	μA
I_{PD}	Weak pulldown Current	$V_{\text{OUT}} = V_{CC}$	30		160	
I_{OZ}	Input Leakage Current	GPIO output disabled	-1		+1	

(1) The sum of all I/O sink/source current must not exceed 100 ma maximum total current into VCC and out of GND.

BACKDRIVE/OVERVOLTAGE I/O DC CHARACTERISTICS

Characteristics for pins RESETN, IRQN, SDA and SCL. Datasheet min/max specification limits are specified by design, test, or statistical analysis. Temperature: $-30^{\circ}\text{C} \leq T_A \leq +85^{\circ}\text{C}$, $V_{CC} = 1.8\text{V} \pm 10\%$, unless otherwise specified.

Symbol	Parameter	Conditions	Min	Typ	Max	Units
V_{IH}	RESETN, SCL, SDA		$0.65 \times V_{CC}$			V
V_{IL}					$0.35 \times V_{CC}$	
I_{Source}	IRQN	$V_{CC} = 1.62\text{V}$ $V_{OH} = 1.17\text{V}$			-16	mA
I_{Sink1}	IRQN	$V_{CC} = 1.62\text{V}$ $V_{OL} = 0.45\text{V}$	16			
I_{Sink2}	SDA	$V_{CC} = 1.62\text{V}$ $V_{OL} = 0.4\text{V}$	3			
I_{Sink3}		$V_{CC} = 1.62\text{V}$ $V_{OL} = 0.6\text{V}$	6			
I_{PU}	IRQN pin as GPIO11 ⁽¹⁾	$V_{OUT} = 0\text{V}$	-160		-30	μA
I_{PD}	IRQN pin as GPIO11 ⁽¹⁾	$V_{OUT} = V_{CC}$	30		160	
I_{OZ1}	Input Leakage Current	GPIO output disabled $1.62\text{V} \leq V_{CC} \leq 1.98\text{V}$ $0 \leq \text{External pin voltage} \leq V_{CC}$	-1		+1	
		GPIO output disabled $1.62\text{V} \leq V_{CC} \leq 1.98\text{V}$ $0 \leq \text{External pin voltage} \leq 2.2\text{V}$	-5		+5	
I_{OZ2}	Input Backdrive Leakage Current	$0 \leq V_{CC} \leq 0.5\text{V}$ $0 \leq \text{External pin voltage} \leq 2.2\text{V}$	-5		+5	μA

(1) This is the internal weak pullup (pulldown) current when driver output is disabled. If enabled, during receiving mode, this is the current required to switch the input from one state to another.

BACKDRIVE I/O AC CHARACTERISTICS

Characteristics for pins SDA and SCL. Datasheet min/max specification limits are specified by design, test, or statistical analysis. Temperature: $-30^{\circ}\text{C} \leq T_A \leq +85^{\circ}\text{C}$, $V_{CC} = 1.8\text{V} \pm 10\%$, unless otherwise specified.

Symbol	Parameter	Conditions	Min	Typ	Max	Units
$t_{Rise/Fall}$	Max. Rise and Fall time ⁽¹⁾	$C_{LOAD} = 50\text{ pF @ }1\text{MHz}$			70	ns
t_{Fall}	Max. Fall Time ACCESS.bus, SDA, SCL ⁽¹⁾	$C_{LOAD} = 10\text{ pF to }100\text{ pF}$ V_{IHmin} to V_{ILmax}	20		300	

(1) Specified by design, not tested.

PIN CONFIGURATION AFTER RESET

Upon power-up or RESET the LM8330 will have defined states on all pins. The following table provides a comprehensive overview of the states of all functional pins.

Pin Configuration after Reset

Pins	Pin States
KPX0 KPX1 KPX2 KPX3 KPX4 KPX5 KPX6 KPX7	Full Buffer mode with an on-chip pullup resistor enabled.
KPY0 KPY1 KPY2 KPY3 KPY4 KPY5 KPY6 KPY7 KPY8 KPY9 KPY10	Full Buffer mode with an on-chip pulldown resistor enabled.
IRQN	Open Drain mode with no pull resistor enabled, driven low. ⁽¹⁾
SCL SDA	Open Drain mode with no pull resistor enabled.

(1) The IRQN is driven low after Power-On Reset due to PORIRQ signal. The value 0x01 must be written to the RSTINTCLR register (0x84) to release the IRQN pin.

TYPICAL APPLICATION SETUP

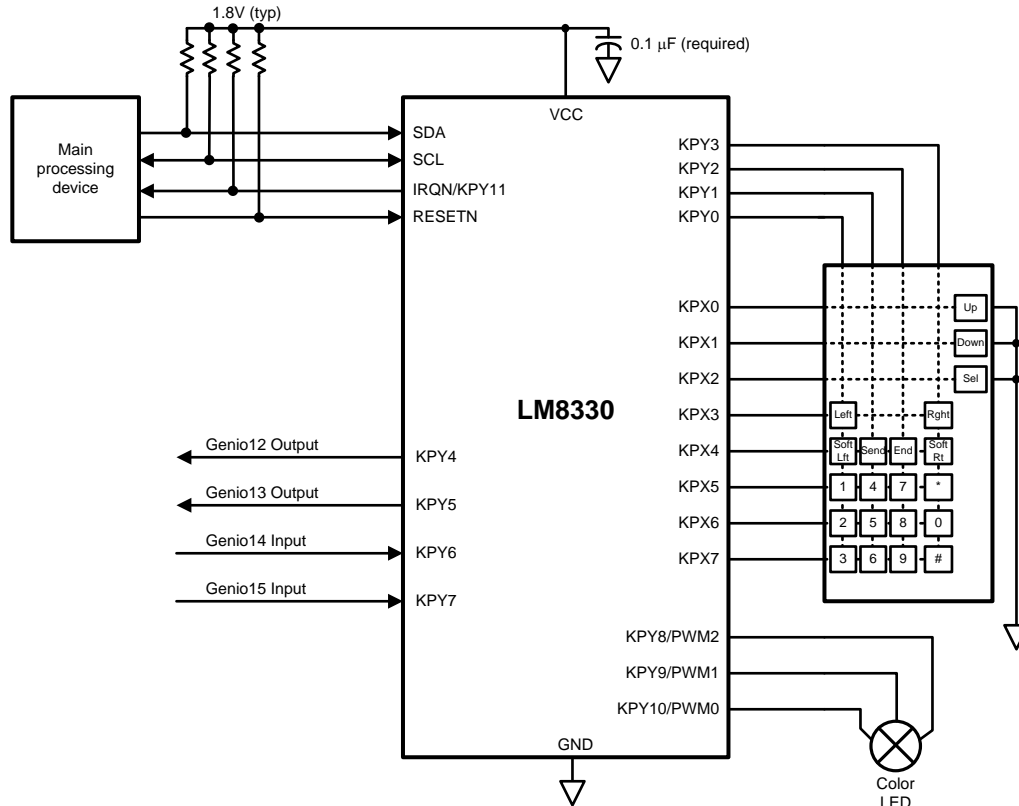

Figure 2. LM8330 in a Typical Setup with Standard Handset Keypad

FEATURES

The following features are supported with the application example shown in example above:

Hardware

Hardware

- 4 x 8 keys and 8 Special Function (SF) keys for 40 keys.
- ACCESS.bus interface for communication with a host device.
 - - Communication speeds supported are: 100 kHz and 400 kHz fast mode of operation.
- Interrupt signal (IRQN) to indicate any keypad or hardware interrupt events to the host.
- Sophisticated PWM function block with 3 independent channels to control color LED.
- External reset input for system control.
- Two host-programmable dedicated general-purpose output pins (GPIOs) supporting IO-expansion capabilities for host device.
- Two host-programmable dedicated general-purpose input pins with wake-up supporting IO-expansion capabilities for host device.

Communication Layer

- Versatile register-based command integration supported from on-chip command interpreter.
- Keypad event storage.
- Individual PWM script file storage and execution control for 3 PWM channels.

HALT MODE

HALT MODE DESCRIPTION

The fully static architecture of the LM8330 allows stopping the internal RC clock in Halt mode, which reduces power consumption to the minimum level.

Halt mode is entered when no key-press event or key-release event is detected for a certain period of time (by default, 1020 milliseconds). The mechanism for entering Halt mode is enabled by default and can be disabled refer to [Table 46](#). The period of inactivity which triggers entry into Halt mode using the auto-sleep function is programmable refer to [Table 47](#).

ACCESS.BUS ACTIVITY

When the LM8330 is in Halt mode an ACCESS.bus access to its Slave Address will not cause the LM8330 to exit from Halt mode. All internal registers are available via ACCESS.bus while in HALT Mode. The LM8330 will acknowledge all bus cycles to its Slave Address while in Halt mode and will not require the host to repeat the cycle.

LM8330 PROGRAMMING INTERFACE

The LM8330 operation is controlled from a host device by a complete register set, accessed via the I²C-compatible ACCESS.bus interface. The ACCESS.bus communication is based on a READ/WRITE structure, following the I²C-compatible transmission protocol.

All functions can be controlled by configuring one or multiple registers. Configuration registers defined as word ACCESS size must have the entire word written in a continuous ACCESS.bus data transfer for the values to take effect. Reading write only registers will always return the value of 0. Please refer to and in LM8330 Registers for the complete register set.

ACCESS.BUS COMMUNICATION

The LM8330 will only be driven in slave mode. The maximum communication speed supported is Fast Mode (FS) which is 400 kHz. [Figure 3](#) shows a typical 7-bit address Read cycle initiated by the host.

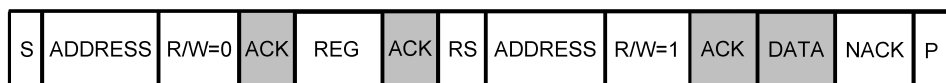

Figure 3. Master/Slave Serial Communication (Host to LM8330)

Table 1. Definition of Terms used in Serial Command Example

Term	Bits	Description
S		START Condition (always generated from the master device).
ADDRESS	7	Slave address of LM8330 sent from the host (7-bit address mode).
R/W	1	This bit determines if the following data transfer is from master to slave (data write) or from slave to master (data read). 0: Write 1: Read
ACK	1	An acknowledge bit is mandatory and must be appended on each byte transfer. The Acknowledge status is actually provided from the slave and indicates to the master that the byte transfer was successful.
REG	8	The first byte after sending the slave address is the REGISTER byte which contains the physical address the host wants to read from or write to.
RS		Repeated START condition.
DATA	8	The DATA field contains information to be stored into a register or information read from a register.
NACK	1	Not Acknowledge Bit. The Not Acknowledge status is assigned from the Master receiving data from a slave. The NACK status will actually be assigned from the master in order to signal the end of a communication cycle transfer.
P		STOP condition (always generated from the master device).

All actions associated with the non-shaded boxes in [Figure 3](#) are controlled from the master (host) device.

All actions associated with the shaded boxes in [Figure 3](#) are controlled from the slave (LM8330) device.

The master device can send subsequent REGISTER addresses separated by Repeated START conditions. A STOP condition must be set from the master at the very end of a communication cycle.

It is recommended to use Repeated START conditions in multi-Master systems when sending subsequent REGISTER addresses. This technique will make sure that the master device communicating with the LM8330 will not lose bus arbitration.

STARTING A COMMUNICATION CYCLE

There are two reasons for the host device to start communication to the LM8330:

1. The LM8330 device has set the IRQN line low in order to signal a key event or any other condition which initializes a hardware interrupt from LM8330 to the host.
2. The host device wants to set a GPIO port, read from a GPIO port, configure a GPIO port, and read the status from a register or initialize any other function which is supported from the LM8330. In case a GPIO shall be read it will be most likely that the LM8330 device will be residing in “sleep mode”. In this mode the system clock will be off to establish the lowest possible current consumption. If the host device starts the communication under this condition, the LM8330 device will acknowledge the first byte if it matches its programmed slave address.

AUTO INCREMENT

In order to improve multi-byte register access, the LM8330 supports the auto increment of the address pointer.

A typical read-access sequence to the LM8330 starts with the I²C-compatible ACCESS.bus address, followed by the REG write of the register to access (see [Figure 3](#)). After a REPEATED START condition the host reads/writes a data byte from/to this address location. The LM8330 automatically increments the address pointer by one until a STOP condition is received. The LM8330 always uses auto increments unless otherwise noted. Please refer to [Table 2](#) and [Table 3](#) for the typical ACCESS.bus flow of reading and writing multiple data bytes.

RESERVED REGISTERS AND BITS

The LM8330 includes reserved registers for future implementation options. Writing to the reserved locations is not allowed and could result in abnormal device behavior.

GENERAL CALL RESET

The LM8330 does not support the Global Call Reset as defined in the NXP (Philips) I²C Specification UM10204 rev 0.3 from 2007.

DEVICE ID

The LM8330 does not support the Device ID as defined in the NXP (Philips) I²C Specification UM10204 rev 0.3 from 2007.

7-BIT and 10-BIT ADDRESSING MODES

The LM8330 supports both the 7-bit and 10-bit addressing modes as defined in the NXP (Philips) I²C Specification UM10204 rev 0.3 from 2007. The default 7-bit slave address is 0x88, and the default 10-bit slave address is 0x088.

NOTE

The upper three address bits in 10-bit mode are hard tied to 0.

Table 2. Multi-Byte Write with Auto Increment

Step	Master/Slave	I ² C Com.	Value	Address Pointer	Comment
1	M	S			START condition
2	M	ADDR	0x88		I ² C-compatible ACCESS.bus Address
3	M	R/W	0		Write
4	S	ACK			Acknowledge
5	M	REG	0xAA	0xAA	Register Address, used as Address Pointer
6	S	ACK		0xAA	Acknowledge
7	M	DATA	0x01	0xAA	Write Data to Address in Pointer
8	S	ACK	0	0xAB	Acknowledge, Address pointer incremented
9	M	DATA	0x05	0xAB	Write Data to address 0xAB
10	S	ACK	0	0xAC	Acknowledge, Address pointer incremented
11	M	P			STOP condition

Table 3. Multi-Byte Read with Auto Increment

Step	Master/Slave	I ² C Com.	Value	Address Pointer	Comment
1	M	S			START condition
2	M	ADDR	0x88		I ² C-compatible ACCESS.bus Address
3	M	R/W	0		Write
4	S	ACK			Acknowledge
5	M	REG	0xAA	0xAA	Register Address, used as Address pointer
6	S	ACK		0xAA	Acknowledge
7	M	RS		0xAA	Repeated Start
8	M	ADDR.	0x88	0xAA	I ² C-compatible ACCESS.bus Address
9	M	R/W	1		Read
10	S	ACK	0	0xAA	Acknowledge
11	S	DATA	0x01	0xAA	Read Data from Address in Pointer
12	M	ACK	0	0xAB	Acknowledge, Address Pointer incremented
13	S	DATA	0x05	0xAB	Read Data from Address in Pointer
14	M	NACK	0	0xAC	No Acknowledge, stops transmission
15	M	P			STOP condition

KEYSCAN OPERATION

KEYSCAN INITIALIZATION

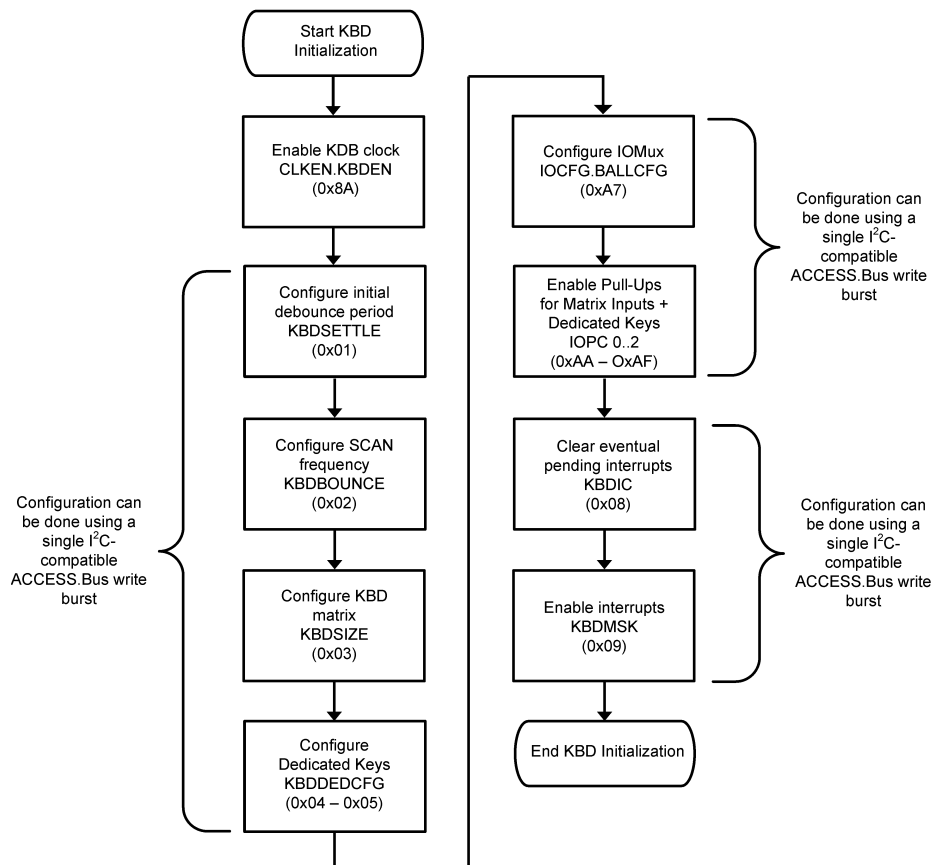

Figure 4. Keyscan Initialization

KEYSCAN INITIALIZATION EXAMPLE

Table 4 shows all the LM8330 register configurations to initialize keyscan:

- Keypad matrix configuration is 8 rows x 8 columns.

Table 4. Keyscan Initialization Example

Register name	adress	Access Type	Value	Comment
KBDSETTLE	0x01	byte	0x80	Set the keyscan settle time to 12 msec.
KBDBOUNCE	0x02	byte	0x80	Set the keyscan debounce time to 12 msec.
KBDSIZE	0x03	byte	0x88	Set the keyscan matrix size to 8 rows x 8 columns.
KBDEDCFG	0x04	word	0xFC3F	Configure KPX[7:2] and KPY[7:2] pins as keyboard matrix.
IOCFG	0xA7	byte	0xF8	Write default value to enable all pins as keyboard matrix.
IOPC0	0xAA	word	0xAAAA	Configure pullup resistors for KPX[7:0].
IOPC1	0xAC	word	0x5555	Configure pulldown resistors for KPY[7:0].
KBDIC	0x08	byte	0x03	clear any pending interrupts.
KBDMSK	0x09	byte	0x03	Enable keyboard interrupts.
CLKEN	0x8A	byte	0x01	Enable keyscan clock.

KEYSCAN PROCESS

The LM8330 keyscan functionality is based on a specific scanning procedure performed in a 4ms interval. On each scan all assigned key matrix pins are evaluated for state changes.

In case a key event has been identified, the event is stored in the key event FIFO, accessible via the EVTCODE register. A key event can either be a key press or a key release. In addition, key presses are also stored in the KBDCODE[3:0] registers. As soon as the EVTCODE FIFO includes a event, the device sets the RAW keyboard event interrupt REVTINT. The RSINT interrupt is set anytime the keyboard status has changed.

Depending on the interrupt masking for the keyboard events (KBDMSK) and the masked interrupt handling (KBDMIS), the pin IRQN will follow the IRQST.KBDIRQ status, which is set as soon as one interrupt in KBDRIS is set.

Figure 5 shows the basic flow of a scanning process and which registers are affected.

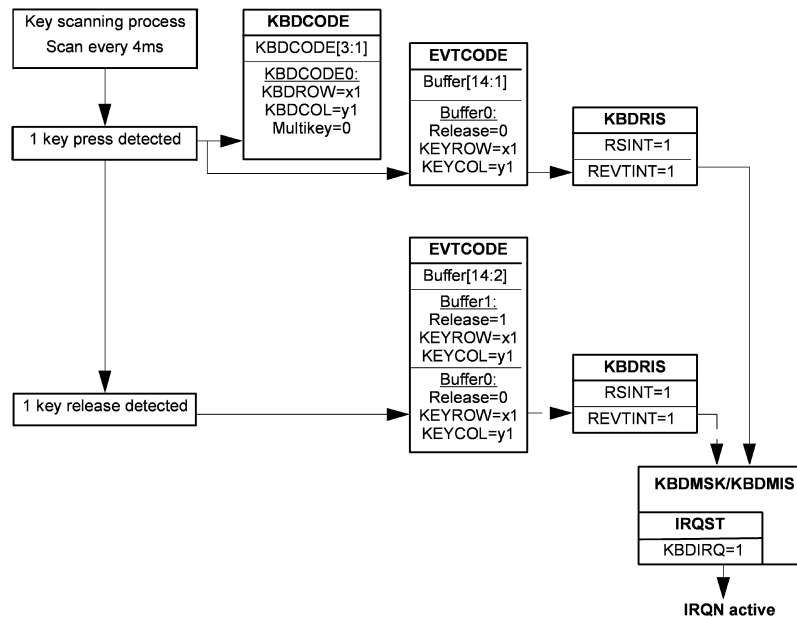

Figure 5. Example Keyscan Operation for 1 Key Press and Release

READING KEYSKAN STATUS BY THE HOST

In order to keep track of the keyscan status, the host either needs to regularly poll the IRQST register or needs to react on the Interrupt signaled by the IRQN pin, in case the ball is configured for interrupt functionality. (See [GPIO FEATURE CONFIGURATION](#)).

Figure 6 gives an example on which registers to read to get the keyboard events from the LM8330 and how they influence the interrupt event registers. The example is based on the assumption that the LM8330 has indicated the keyboard event by the IRQN pin.

Since the interrupt pin has various sources, the host first checks the IRQST register for the interrupt source. If KBDIRQ is set, the host can check the KBDMIS register to define the exact interrupt source. KBDMIS contains the masked status of KBDRIS and reflects the source for raising the interrupt pin. The interrupt mask is defined by KBDMSK. The complete status of all pending keyboard interrupts is available in the raw interrupt register KBDRIS.

After evaluating the interrupt source the host starts reading the EVTCODE or KBDCODE register. In this example the host first reads the KBDCODE to get possible key press events and afterwards reads the complete event list by reading the EVTCODE register until all events are captured (0x7F indicates end of buffer).

Reading KBDCODE clears the RSINT interrupt bit if all keyboards events are emptied. In the same way, REVTINT is cleared in case the EVTCODE FIFO reaches its empty state on read.

The event buffer content and the REVTINT and RELINT (lost event) interrupt bits are also cleared if the KBDIC.EVTIC bit is set.

Interrupt bits in the masked interrupt register KBDMIS follow the masked KBDRIS status.

In order to support efficient Multi-byte reads from EVTCODE, the auto-increment feature is turned off for this register. Therefore the host can continuously read the complete EVTCODE buffer by sending one command.

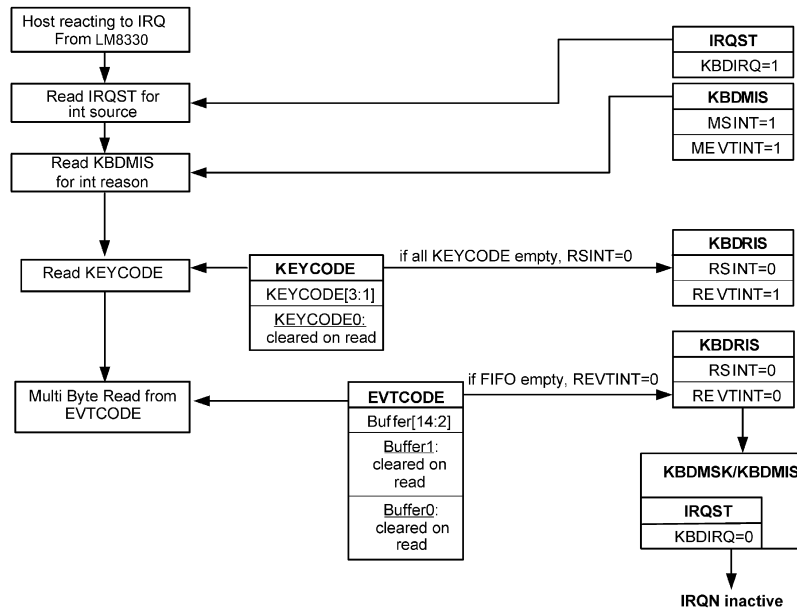

Figure 6. Example Host Reacting to Interrupt for Keypad Event

MULTIPLE KEY PRESSES

The LM8330 supports up to four simultaneous key presses. Any time a single key is pressed KBDCODE0 is set with the appropriate key code. If a second key is pressed, the key is stored in KBDCODE1 and the MULTIKEY flag of KBDCODE0 is set. Additional key presses are stored in KBDCODE2 and KBDCODE3 accordingly. The four registers signal the last multi key press events.

All events are stored in parallel in the EVTCODE register for the complete set of events.

All KBDCODE[3:0] registers are cleared on read.

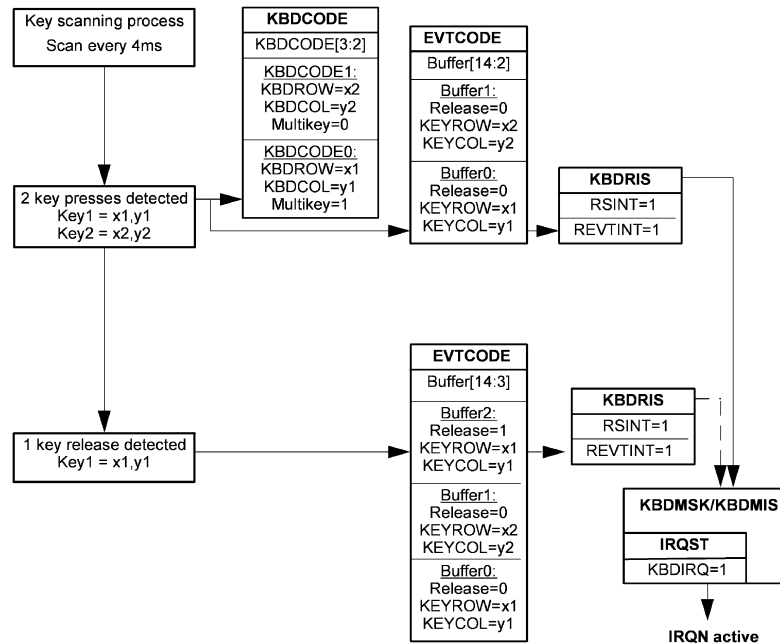

Figure 7. Example Keyscan Operation for 2 Key Press Events and 1 Key Release Event

PWM TIMER

The LM8330 supports a timer module dedicated to smooth LED control techniques.

The Pulse Modulation Width (PWM) timer module consists of three independent timer units of which each can generate a PWM output with a fixed period and automatically incrementing or decrementing variable duty cycle. The timer units are all clocked with a slow (32 kHz) clock.

OVERVIEW OF PWM FEATURES

- Each PWM can establish fixed - or variable - duty-cycle signal sequences on its output.
- Each PWM can trigger execution of any pre-programmed task on another PWM channel.
- The execution of any pre-programmed task is self-sustaining and does not require further interaction from the host.
- 31-instruction script buffer for each PWM.
- Direct addressing within script buffer to support multiple PWM tasks in one buffer.

OVERVIEW ON PWM SCRIPT COMMANDS

The commands listed in [Table 5](#) are dedicated to the slow PWM timers.

NOTE

If the last address in the PWM script buffer is reached, and that command is not an END command, an END command with INT & RST enabled will be forced and the PWM operation will be terminated. **Please note:** The PWM Script commands are not part of the command set supported by the LM8330 command interpreter. These commands must be transferred from the host with help of the register-based command set.

Table 5. PWM Script Commands

Command	15	14	13	12	11	10	9	8	7	6	5	4	3	2	1	0	
RAMP	0	PRESCALE	STEPTIME					SIGN	INCREMENT								
SET_PWM	0	1	0					PWM VALUE									
GO_TO_ START	0																
BRANCH	1	0	1	LOOPCOUNT					ADDR	X	STEPNUMBER						
END	1	1	0	INT	RST	X											
TRIGGER	1	1	1	WAITTRIGGER					SENDTRIGGER							0	

RAMP Command

A RAMP command will vary the duty cycle of a PWM output in either direction (up or down). The INCREMENT field specifies the amount of steps for the RAMP. The maximum amount of steps which can be executed with one RAMP Command is 126 which is equivalent to 50%. The SIGN bit field determines the direction of a RAMP (up or down). The STEPTIME field and the PRESCALE bit determine the duration of one step. Based on a 32 kHz clock, the minimum time resulting from these options would be 0.49 milliseconds and the maximum time for one step would be 1 second.

Table 6. RAMP Command Bit and Building Fields

15	14	13	12	11	10	9	8	7	6	5	4	3	2	1	0	
0	PRESCALE	STEPTIME					SIGN	INCREMENT								

Table 7. Description of Bit and Building Fields of the RAMP Command

Bit or Field	Value	Description
PRESCALE	0	Divide the 32 kHz clock by 16.
	1	Divide the 32 kHz clock by 512.
STEPTIME	1 - 63	Number of prescaled clock cycles per step.
SIGN	0	Increment RAMP counter.
	1	Decrement RAMP counter.
INCREMENT	0 - 126	Number of steps executed by this instruction; a value of 0 functions as a WAIT determined by STEPTIME.

SET_PWM Command

The SET_PWM command does not allow generation of a PWM output with a fixed duty cycle between 0% and 100%. This command will set the starting duty cycle MIN SCALE or FULL SCALE (0% or 100%). A RAMP command following the SET_PWM command will finally establish the desired duty cycle on the PWM output.

Table 8. SET_PWM Command Bit and Building Fields

15	14	13	12	11	10	9	8	7	6	5	4	3	2	1	0
0	1	0	0	0	0	0	0	DUTYCYCLE							

Table 9. Description of Bit and Building Fields of the SET_PWM Command

Bit or Field	Value	Description
DUTYCYCLE	0	Duty cycle is 0%.
	255	Duty cycle is 100%.

GO_TO_START Command

The GO_TO_START command jumps to the first command in the script command file.

Table 10. GO_TO_START Command Bit and Building Fields

15	14	13	12	11	10	9	8	7	6	5	4	3	2	1	0
0															

BRANCH Command

The BRANCH command jumps to the specified command in the script command file. The branch is executed with either absolute or relative addressing. In addition, the command gives the option of looping for a specified number of repetitions.

NOTE

Nested loops are not allowed.

Table 11. BRANCH Command Bit and Building Fields

15	14	13	12	11	10	9	8	7	6	5	4	3	2	1	0	
1	0	1	LOOPCOUNT					ADDR	X	STEPNUMBER						

Table 12. Description of Bit and Building Fields of the BRANCH Command

Bit or Field	Value	Description
LOOPCOUNT	0	Loop until a STOP PWM SCRIPT command is issued by the host.
	1 - 63	Number of loops to perform.
ADDR	0	Absolute addressing
	1	Relative addressing
STEPNUMBER	0 - 31	Depending on ADDR: ADDR=0: Addr to jump to ADDR=1: Number of backward steps

TRIGGER Command

Triggers are used to synchronize operations between PWM channels. A TRIGGER command that sends a trigger takes sixteen 32 kHz clock cycles, and a command that waits for a trigger takes at least sixteen 32 kHz clock cycles.

A TRIGGER command that waits for a trigger (or triggers) will stall script execution until the trigger conditions are satisfied. On trigger it will clear the trigger(s) and continue to the next command.

When a trigger is sent, it is stored by the receiving channel and can only be cleared when the receiving channel executes a TRIGGER command that waits for the trigger.

Table 13. TRIGGER Command Bit and Building Fields

15	14	13	12	11	10	9	8	7	6	5	4	3	2	1	0
1	1	1	WAITTRIGGER					SENDTRIGGER							0

Table 14. Description of Bit and Building Fields

Field	Value	Description
WAITTRIGGER	000xx1	Wait for trigger from channel 0
	000x1x	Wait for trigger from channel 1
	0001xx	Wait for trigger from channel 2
SENDTRIGGER	000xx1	Send trigger to channel 0
	000x1x	Send trigger to channel 1
	0001xx	Send trigger to channel 2

END COMMAND

The END command terminates script execution. It will only assert an interrupt to the host if the INT bit is set to '1'.

When the END command is executed, the PWM output will be set to the level defined by PWMCFG.PWMPOL for this channel. Also, the script counter is reset back to the beginning of the script command buffer.

NOTE

If a PWM channel is waiting for the trigger (last executed command was "TRIGGER"), and the script execution is halted, then the "END" command can't be executed because the previous command is still pending. This is an exception - in this case the IRQ signal will not be asserted.

Table 15. END Command Bit and Building Fields

15	14	13	12	11	10	9	8	7	6	5	4	3	2	1	0
1	1	0	INT	RST						0					

Table 16. Description of Bit and Building Fields of the END Command

Field	Value	Description
INT	0	No interrupt will be sent.
	1	Set TIMRIS.CDIRQ for this PWM channel to notify that program has ended.
RST	0	The PWM Output is set Low.
	1	The PWM Output is set according to PWMCFG.PWMPOL.

LM8330 REGISTER SET**KEYBOARD REGISTERS AND KEYBOARD CONTROL**

Keyboard selection and control registers are mapped in the address range from 0x01 to 0x09. This paragraph describes the functions of the associated registers down to the bit level.

KBDSETTLE - Keypad Settle Time Register**Table 17. KBDSETTLE - Keypad Settle Time Register**

Register - Name	Address	Type	Register Function
KBDSETTLE	0x01	R/W	Initial time for keys to settle, before the key-scan process is started. The Keypad settle time will be imposed under the following conditions: a. A wake-up event on the keypad input (if KBDEN=1) b. The MODCTL register bit is written to transition from "halt" to "operational" mode (if KBDEN=1).
Bit - Name	Bit	Default	Bit Function
WAIT[7:0]	7:0	0x80	The default value 0x80 : 0xBF sets a time target of 12 msec. Further time targets are as follows: 0xC0 - 0xFF: 16 msec 0x80 - 0xBF: 12 msec 0x40 - 0x7F: 8 msec 0x01 - 0x3F: 4 msec 0x00 : no settle time

KBDBOUNCE - Debounce Time Register**Table 18. KBDBOUNCE - Debounce Time Register**

Register - Name	Address	Type	Register Function
KBDBOUNCE	0x02	R/W	Time between first detection of key and final sampling of key.
Bit - Name	Bit	Default	Bit Function

Table 18. KBDBOUNCE - Debounce Time Register (continued)

Register - Name	Address	Type	Register Function
WAIT[7:0]	7:0	0x80	The default value 0x80 : 0xBF sets a time target of 12 msec. Further time targets are as follows: 0xC0 - 0xFF: 16 msec 0x80 - 0xBF: 12 msec 0x40 - 0x7F: 8 msec 0x01 - 0x3F: 4 msec 0x00: no debouncing time

KBDSIZE - Set Keypad Size Register
Table 19. KBDSIZE - Set Keypad Size Register

Register - Name	Address	Type	Register Function
KBDSIZE	0x03	R/W	Defines the physical keyboard matrix size.
Bit - Name	Bit	Default	Bit Function
ROWSIZE[3:0]	7:4	0x2	Number of rows in the keyboard matrix: 0x0: free all rows to become GPIO, KPX[1:0] used as dedicated key inputs if scanning is enabled by CLKEN.KBEN: 0x1: (illegal value) 0x2 - 0x8: Number of rows in the matrix
COLSIZE[3:0]	3:0	0x2	Number of columns in the keyboard matrix: 0x0: free all rows to become GPIO, KPY[1:0] used as dedicated key inputs if scanning is enabled by CLKEN.KBEN 0x1: (illegal value) 0x2 - 0xC: Number of columns in the matrix

KBDEDCFG - Dedicated Key Register
Table 20. KBDEDCFG - Dedicated Key Register

Register - Name	Address	Type	Register Function
KBDEDCFG	0x04	R/W	Defines if a key is used as a standard keyboard/GPIO pin or whether it is used as dedicated key input.
Bit - Name	Bit	Default	Bit Function
ROW[7:2]	15:10	0x3F	Each bit in ROW [7:2] corresponds to ball KPX7 : KPX2. Bit=0: the dedicated key function applies. Bit=1: no dedicated key function is selected. The standard GPIO functionality applies according to register IOCFG or defined keyboard matrix.
COL[11:10]	9:8	0x03	Each bit in COL [11:10] corresponds to ball KPY11 : KPY10. Bit=0: the dedicated key function applies. Bit=1: no dedicated key function is selected. The standard GPIO functionality applies according to register IOCFG or defined keyboard matrix.
COL[9:2]	7:0	0xFF	Each bit in COL [9:2] corresponds to ball KPY9 : KPY2 and can be configured individually. Bit=0: the dedicated key function applies. Bit=1: no dedicated key function is selected. The standard GPIO functionality applies according to register IOCFG or defined keyboard matrix.

KBDRIS - Keyboard Raw Interrupt Status Register**Table 21. KBDRIS - Keyboard Raw Interrupt Status Register**

Register - Name	Address	Type	Register Function
KBDRIS	0x06	R	Returns the status of stored keyboard interrupts.
Bit - Name	Bit	Default	Bit Function
(reserved)	7:4		(reserved)
RELINT	3	0x0	Raw event lost interrupt. More than 16 keyboard events have been detected and caused the event buffer to overflow. This bit is cleared by setting bit EVTIC of the KBDIC register.
REVTINT	2	0x0	Raw keyboard event interrupt. At least one key press or key release is in the keyboard event buffer. Reading from EVTCODE until the buffer is empty will clear this interrupt.
RKLINT	1	0x0	Raw key lost interrupt indicates a lost key-code. This interrupt is asserted when RSINT has not been cleared upon detection of a new key press or key release, or when more than 4 keys are pressed simultaneously.
RSINT	0	0x0	Raw scan interrupt. Interrupt generated after keyboard scan, if the keyboard status has changed. Reading from KBDCODE until the buffer is empty will clear this interrupt.

KBDMIS - Keypad Masked Interrupt Status Register**Table 22. KBDMIS - Keypad Masked Interrupt Status Register**

Register - Name	Address	Type	Register Function
KBDMIS	0x07	R	Returns the status on masked keyboard interrupts after masking with the KBDMSK register.
Bit - Name	Bit	Default	Bit Functions
(reserved)	7:4		(reserved)
MELINT	3	0x0	Masked event lost interrupt. More than 16 keyboard events have been detected and caused the event buffer to overflow. This bit is cleared by setting bit EVTIC of the KBDIC register.
MEVTINT	2	0x0	Masked keyboard event interrupt. At least one key press or key release is in the keyboard event buffer. Reading from EVTCODE until the buffer is empty will clear this interrupt.
MKLINT	1	0x0	Masked key lost interrupt. Indicates a lost key-code. This interrupt is asserted when RSINT has not been cleared upon detection of a new key press or key release, or when more than 4 keys are pressed simultaneously.
MSINT	0	0x0	Masked scan interrupt. Interrupt generated after keyboard scan, if the keyboard status has changed, after masking process. Reading from KBDCODE until the buffer is empty will clear this interrupt.

KBDIC - Keypad Interrupt Clear Register**Table 23. KBDIC - Keypad Interrupt Clear Register**

Register - Name	Address	Default	Register Function
KBDIC	0x08	W	Setting these bits clears Keypad active Interrupts
Bit - Name	Bit	Default	Bit Function

Table 23. KBDIC - Keypad Interrupt Clear Register (continued)

Register - Name	Address	Default	Register Function
SFOFF	7		Switches off scanning of special function (SF) keys, when keyboard has no special function layout: 0: keyboard layout and SF keys are scanned 1: only keyboard layout is scanned, SF keys are not scanned
(reserved)	6:2		(reserved)
EVTIC	1		Clear EVTCODE FIFO and corresponding interrupts REVTINT and RELINT by writing a 1 to this bit position. Note: Any key data in the EVTCODE FIFO will be lost when this bit is set; it is the users responsibility to ensure that all key data is read prior to asserting this bit. If a key is pressed while EVTIC is asserted/de-asserted the EVTCODE FIFO will be updated with only the key release code when the key is released.
KBDIC	0		Clear RSINT and RKLINT interrupt bits by writing a '1' to this bit position. Note The KBDCODE registers are not cleared when setting this bit.

KBDMSK - Keypad Interrupt Mask Register
Table 24. KBDMSK - Keypad Interrupt Mask Register

Register - Name	Address	Type	Register Function
KBDMSK	0x09	R/W	Configures masking of keyboard interrupts. Masked interrupts do not trigger an event on the Interrupt output. In case the interrupt processes registers KBDCODE[3:0], MSKELINT and MSKEINT should be set to '1'. When the Event FIFO is processed, MSKLINT and MSKSINT should be set. For keyboard polling operations, all bits should be set and the polling operation consists of reading out the IRQST.
Bit - Name	Bit	Default	Bit Function
(reserved)	7:4		(reserved)
MSKELINT	3	0x0	0: keyboard event lost interrupt RELINT triggers IRQ line 1: keyboard event lost interrupt RELINT is masked
MSKEINT	2	0x0	0: keyboard event interrupt REVINT triggers IRQ line 1: keyboard event interrupt REVINT is masked
MSKLINT	1	0x1	0: keyboard lost interrupt RKLINT triggers IRQ line 1: keyboard lost interrupt RKLINT is masked
MSKSINT	0	0x1	0: keyboard status interrupt RSINT triggers IRQ line 1: keyboard status interrupt RSINT is masked

KEYBOARD CODE DETECT REGISTERS

The key code detected by the keyboard scan can be read from the registers KBDCODE0: KBDCODE3. Up to 4 keys can be detected simultaneously. Each KBDCODE register includes a bit (MULTIKEY) indicating if another key has been detected.

NOTE

Reading out all key code registers (KBDCODE0 to KBDCODE3) will automatically reset the keyboard scan interrupt RSINT the same way as an active write access into bit KBDIC of the interrupt clear register does. Reading 0x7F from the KBDCODE0 register means that no key was pressed.

KBDCODE0 - Keyboard Code Register 0**Table 25. KBDCODE0 - Keyboard Code Register 0**

Register - Name	Address	Default	Register Function
KBDCODE0	0x0B	R	Holds the row and column information of the first detected key.
Bit - Name	Bit	Default	Bit Function
MULTIKEY	7	0x0	If this bit is 1 another key is available in KBDCODE1 register.
KEYROW[2:0]	6:4	0x7	ROW index of detected key (0 to 7).
KEYCOL[3:0]	3:0	0xF	Column index of detected (0 to 11, 12 for special function key and 13 & 14 for dedicated KPY key).

KBDCODE1 - Keyboard Code Register 1**Table 26. KBDCODE1 - Keyboard Code Register 1**

Register - Name	Address	Default	Register Function
KBDCODE1	0x0C	R	Holds the row and column information of the second detected key.
Bit - Name	Bit	Default	Bit Function
MULTIKEY	7	0x0	If this bit is 1 another key is available in KBDCODE2 register.
KEYROW[2:0]	6:4	0x7	ROW index of detected key (0 to 7).
KEYCOL[3:0]	3:0	0xF	Column index of detected key (0 to 11, 12 for special function key and 13 & 14 for dedicated KPY key).

KBDCODE2 - Keyboard Code Register 2**Table 27. KBDCODE2 - Keyboard Code Register 2**

Register - Name	Address	Default	Register Function
KBDCODE2	0x0D	R	Holds the row and column information of the third detected key.
Bit - Name	Bit	Default	Bit Function
MULTIKEY	7	0x0	if this bit is 1 another key is available in KBDCODE3 register.
KEYROW[2:0]	6:4	0x7	ROW index of detected key (0 to 7).
KEYCOL[3:0]	3:0	0xF	Column index of detected key (0 to 11, 12 for special function key and 13 & 14 for dedicated KPY key).

KBDCODE3 - Keyboard Code Register 3**Table 28. KBDCODE3 - Keyboard Code Register 3**

Register - Name	Address	Default	Register Function
KBDCODE3	0x0E	R	Holds the row and column information of the fourth detected key.
Bit - Name	Bit	Default	Bit Function
MULTIKEY	7	0x0	if this bit is set to '1' then more than 4 keys are pressed simultaneously.
KEYROW[2:0]	6:4	0x7	ROW index of detected key (0 to 7).
KEYCOL[3:0]	3:0	0xF	Column index of detected key (0 to 11, 12 for special function key and 13 & 14 for dedicated KPY key).

EVTCODE - Key Event Code Register
Table 29. EVTCODE - Key Event Code Register

Register - Name	Address	Default	Bit Function
EVTCODE	0x10	R	With this register a FIFO buffer is addressed storing up to 15 consecutive events. Reading the value 0x7F from this address means that the FIFO buffer is empty. See further details below. NOTE: Auto increment is disabled on this register. Multi-byte read will always read from the same address.
Bit - Name	Bit	Default	Bit Function
RELEASE	7	0x0	This bit indicates whether the keyboard event was a key press or a key release event: 0: key was pressed 1: key was released
KEYROW[2:0]	6:4	0x7	Row index of key that is pressed or released.
KEYCOL[3:0]	3:0	0xF	Column index of detected key that is pressed (0 to 11, 12 for special function key or and 13 & 14 for dedicated key) or released.

PWM TIMER CONTROL REGISTERS

The LM8330 provides three host-programmable PWM outputs useful for smooth LED brightness modulation. All PWM timer control registers are mapped in the range from 0x60 to 0x7F. This paragraph describes the functions of the associated registers down to the bit level.

TIMCFGx - PWM Timer 0, 1 and 2 Configuration Register
Table 30. TIMCFGx - PWM Timer 0, 1 and 2 Configuration Register

Register - Name	Address	Type	Register Function
TIMCFG0	0x60	R/W	This register configures interrupt masking of the associated PWM channel.
TIMCFG1	0x68		
TIMCFG2	0x70		
Bit - Name (x = 0, 1 or 2)	Bit	Default	Bit Function
CYCIRQxMSK	4	0x0	Interrupt mask for PWM CYCIRQx (see register TIMRIS): 0: interrupt enabled 1: interrupt masked
(reserved)	3:0	0x0	(reserved)

PWMCFGx - PWM Timer 0, 1 and 2 Configuration Control Register
Table 31. PWMCFGx - PWM Timer 0, 1 and 2 Configuration Control Register

Register - Name	Address	Type	Register Function
PWMCFG0	0x61	R/W	This register defines interrupt masking and the output behavior for the associated PWM channel. PGEx is used to start and stop the PWM script execution. PWMENx sets the PWM output to either reflect the generated pattern or the value configured in PWMPOLx.
PWMCFG1	0x69		
PWMCFG2	0x71		
Bit - Name (x = 0, 1 or 2)	Bit	Default	Bit Function
CDIRQxMSK	3	0x0	Mask for CDIRQ: 0: CDIRQ enabled 1: CDIRQ disabled/masked

Table 31. PWMCFGx - PWM Timer 0, 1 and 2 Configuration Control Register (continued)

Register - Name	Address	Type	Register Function
PGE _x	2	0x0	Pattern Generator Enable. Start/Stop PWM command processing for this channel. Script execution is started always from beginning. 0: Pattern Generator disabled 1: Pattern Generator enabled Notes: ¹⁾ This bit will be cleared when the PWM completes execution of END command and END.RST = 1. ²⁾ The PWM will complete execution of an active script command if this bit is set to 0 by the host.
PWMEN _x	1	0x0	0: PWM disabled. PWM timer output assumes value programmed in PWMPOL. 1: PWM enabled
PWMPOL _x	0	0x0	Off-state of PWM output, when PWMEN = 0: 0: PWM off-state is low 1: PWM off-state is high

TIMSWRES - PWM Timer Software Reset Registers**Table 32. TIMSWRES - PWM Timer Software Reset Registers**

Register - Name	Address	Type	Register Function
TIMSWRES	0x78	W	Reset control on all PWM timers. A reset forces the pattern generator to fetch the first pattern and stops it. Each reset stops all state-machines and timer. Patterns stored in the pattern configuration register remain unaffected. Interrupts on each timer are not cleared, they need to be cleared writing into register TIMIC.
Bit - Name	Bit	Default	Bit Function
(reserved)	7:3		(reserved)
SWRES2	2		Software reset of timer 2: 0: no action 1: Software reset on timer 2, needs not to be written back to 0.
SWRES1	1		Software reset of timer 1 0: no action 1: Software reset on timer 1, needs not to be written back to 0.
SWRES0	0		Software reset of timer 0: 0: no action 1: software reset on timer 0, needs not to be written back to '0'.

TIMRIS - PWM Timer Interrupt Status Register**Table 33. TIMRIS - PWM Timer Interrupt Status Register**

Register - Name	Address	Type	Register Function
TIMRIS	0x7A	R	This register returns the raw interrupt status from the PWM timers 0,1 and 2. CYCIRQ_x - Interrupt from the timers when PWM cycle is complete (applies to the current PWM command residing in the active command register of a PWM block). CDIRQ_x - Interrupt from the pattern generator when PWM pattern code is complete (applies to a completed task residing in the script buffer of a PWM block).
Bit - Name	Bit	Default	Bit Functions
(reserved)	7:6		(reserved)

Table 33. TIMRIS - PWM Timer Interrupt Status Register (continued)

Register - Name	Address	Type	Register Function
CDIRQ2	5	0x0	Raw interrupt status for CDIRQ timer2: 0: no interrupt pending 1: unmasked interrupt generated
CDIRQ1	4	0x0	Raw interrupt status for CDIRQ timer1: 0: no interrupt pending 1: unmasked interrupt generated
CDIRQ0	3	0x0	Raw interrupt status for CDIRQ timer0: 0: no interrupt pending 1: unmasked interrupt generated
CYCIRQ2	2	0x0	Raw interrupt status for CYCIRQ timer2: 0: no interrupt pending 1: unmasked interrupt generated
CYCIRQ1	1	0x0	Raw interrupt status for CYCIRQ timer1: 0: no interrupt pending 1: unmasked interrupt generated
CYCIRQ0	0	0x0	Raw interrupt status for CYCIRQ timer0: 0: no interrupt pending 1: unmasked interrupt generated

TIMMIS - PWM Timer Masked Interrupt Status Register
Table 34. TIMMIS - PWM Timer Masked Interrupt Status Register

Register - Name	Address	Type	Register Function
TIMMIS	0x7B	R	This register returns the masked interrupt status from the PWM timers 0, 1 and 2. The raw interrupt status (TIMRIS) is masked with the associated TIMCFGx.CYCIRQxMSK and PWMCFGx.CDIRQxMSK bits to get the masked interrupt status of this register. CYCIRQ - Interrupt from the timers when PWM cycle is complete (applies to the current PWM command residing in the active command register of a PWM block). CDIRQ - Interrupt from the pattern generator when PWM pattern code is complete (applies to a completed task residing in the script buffer of a PWM block).
Bit - Name	Bit	Default	Bit Function
(reserved)	7:6		(reserved)
CDIRQ2	5	0x0	Interrupt after masking, indicates active contribution to the interrupt ball, when set. Status for CDIRQ timer2: 0: no interrupt pending 1: interrupt generated
CDIRQ1	4	0x0	Interrupt after masking, indicates active contribution to the interrupt ball, when set. Status for CDIRQ timer1: 0: no interrupt pending 1: interrupt generated
CDIRQ0	3	0x0	Interrupt after masking, indicates active contribution to the interrupt ball, when set. Status for CDIRQ timer0: 0: no interrupt pending 1: interrupt generated
CYCIRQ2	2	0x0	Interrupt after masking, indicates active contribution to the interrupt ball, when set. Status for CYCIRQ timer2: 0: no interrupt pending 1: interrupt generated

Table 34. TIMMIS - PWM Timer Masked Interrupt Status Register (continued)

Register - Name	Address	Type	Register Function
CYCIRQ1	1	0x0	Interrupt after masking, indicates active contribution to the interrupt ball, when set. Status for CYCIRQ timer1: 0: no interrupt pending 1: interrupt generated
CYCIRQ0	0	0x0	Interrupt after masking, indicates active contribution to the interrupt ball, when set. Status for CYCIRQ timer0: 0: no interrupt pending 1: interrupt generated

TIMIC - PWM Timer Interrupt Clear Register**Table 35. TIMIC - PWM Timer Interrupt Clear Register**

Register - Name	Address	Type	Register Function
TIMIC	0x7C	W	This register clears timer and pattern interrupts. CYCIRQ - Interrupt from the timers when PWM cycle is complete (applies to the current PWM command residing in the active command register of a PWM block). CDIRQ - Interrupt from the pattern generator when PWM pattern code is complete (applies to a completed task residing in the script buffer of a PWM block).
Bit - Name	Bit	Default	Bit Function
(reserved)	7:6		(reserved)
CDIRQ2	5		Clears interrupt CDIRQ timer2: 0: no effect 1: interrupt is cleared. Does not need to be written back to 0
CDIRQ1	4		Clears interrupt CDIRQ timer1: 0: no effect 1: interrupt is cleared. Does not need to be written back to 0
CDIRQ0	3		Clears interrupt CDIRQ timer0: 0: no effect 1: interrupt is cleared. Does not need to be written back to 0
CYCIRQ2	2		Clears interrupt CYCIRQ timer2: 0: no effect 1: interrupt is cleared. Does not need to be written back to 0
CYCIRQ1	1		Clears interrupt CYCIRQ timer1: 0: no effect 1: interrupt is cleared. Does not need to be written back to 0
CYCIRQ0	0		Clears interrupt CYCIRQ timer0: 0: no effect 1: interrupt is cleared. Does not need to be written back to 0

PWMWP - PWM Timer Pattern Pointer Register**Table 36. PWMWP - PWM Timer Pattern Pointer Register**

Register - Name	Address	Type	Register Function
PWMWP	0x7D	R/W	Pointer to the pattern position inside the configuration register, which will be overwritten by the next write access to be PWMCFG register. NOTE: 1 pattern consists of 2 bytes and not the byte position (low or high). It is incremented by 1 every time a full PWMCFG register access (word) is performed.
Bit - Name	Bit	Default	Bit Function

Table 36. PWMWP - PWM Timer Pattern Pointer Register (continued)

Register - Name	Address	Type	Register Function
(reserved)	7	0x0	(reserved)
POINTER[6:0]	6:0	0x0	0 ≤ POINTER < 32 : timer0 patterns 0 to 31 32 ≤ POINTER < 64 : timer1 patterns 0 to 31 64 ≤ POINTER < 96 : timer2 patterns 0 to 31 96 ≤ POINTER < 128: not valid

PWMCFG - PWM Script Register
Table 37. PWMCFG - PWM Script Register

Register - Name	Address	Type	Register Function
PWMCFG	0x7E	W	Two-byte pattern storage register for a PWM script command indexed by PWMWP. PWMWP is automatically incremented. To be applied by two consecutive parameter bytes in one I ² C Write Transaction. NOTE: Auto-increment is disabled on this register. Address will stay at 0x7E for each word access.
Bit - Name	Bit	Default	Bit Function
CMD[15:8]	15:8		High byte portion of a PWM script command
CMD[7:0]	7:0		Low byte portion of a PWM script command

INTERFACE CONTROL REGISTERS

The following section describes the functions of special control registers provided for the main controller.

The manufacturer code MFGCODE and the software revision number SWREV tell the main device which configuration file has to be used for this device.

NOTE

I²CSA and MFGCODE use the same address. They just differentiate in the access type:

- Write - I²CSA
- Read - MFGCODE

I²CSA - I²C-Compatible ACCESS.bus 10-Bit & 7-Bit Slave Address Register
Table 38. I²CSA - I²C-Compatible ACCESS.bus 10-Bit & 7-Bit Slave Address Register

Register - Name	Address	Type	Register Function
I ² CSA	0x80	W	I ² C-compatible ACCESS.bus Slave Address. The address is internally applied after the next I ² C STOP.
Bit - Name	Bit	Default	Bit Function
SLAVEADDR[7:1]	7:1	0x44	10-bit & 7-bit address field for the I ² C-compatible ACCESS.bus slave address (10-bit: upper three bits = 0).
(reserved)	0		(reserved)

MFGCODE - Manufacturer Code Register
Table 39. MFGCODE - Manufacturer Code Register

Register - Name	Address	Type	Register Function
MFGCODE	0x80	R	Manufacturer code of the LM8330.
Bit - Name	Bit	Default	Bit Function
MFGBIT	7:0	0x00	8-bit field containing the manufacturer code.

SWREV - Software Revision Register**Table 40. SWREV - Software Revision Register**

Register - Name	Address	Type	Register Function
SWREV	0x81	R	Software revision code of the LM8330. NOTE: writing the SW revision with the inverted value triggers a reset (see SWRESET - Software Reset).
Bit - Name	Bit	Default	Bit Function
SWBIT	7:0	0x84	8 - bit field containing the SW Revision number.

SWRESET - Software Reset**Table 41. SWRESET - Software Reset Register**

Register - Name	Address	Type	Register Function
SWRESET	0x81	W	Software reset NOTE: the reset is only applied if the supplied parameter has the inverted value as SWBIT. Reading this register provides the software revision (see SWREV - Software Revision Register).
Bit - Name	Bit	Default	Bit Function
SWBIT	7:0		Reapply inverted value for software reset.

RSTCTRL - System Reset Register

This register allows resetting specific blocks of the LM8330. These bits are not self-clearing and must be written to a value of '0' to release the block specific reset. All registers associated with the block specific reset will be initialized to their default value. During an active reset of a module, the LM8330 will not block the access to the module registers. A read will return the default value, write commands may or may not be ignored. (Refer to each block-specific reset bit for additional details.)

Table 42. RSTCTRL - System Reset Register

Register - Name	Address	Type	Register Function
RSTCTRL	0x82	R/W	Software reset of specific parts of the LM8330.
Bit - Name	Bit	Default	Bit Function
(reserved)	7:5		(reserved)
IRQRST	4	0x0	Interrupt controller reset. Does not change status on IRQN ball. Only controls IRQ module register. An interrupt status register read when this bit is set will return a value of 0 even if there is an Interrupt Status bit set. Pending interrupts will be accumulated and held until IRQRST bit is released. Any interrupt can be cleared while IRQRST is active: 0: interrupt controller not reset 1: interrupt controller reset
TIMRST	3	0x0	Timer reset for Timers 0, 1, 2: 0: timer not reset 1: timer is reset
(reserved)	2	0x0	(reserved)
KBDRST	1	0x0	Keyboard interface reset: 0: keyboard is not reset 1: keyboard is reset
GPIRST	0	0x0	GPIO reset: 0: GPIO not reset 1: GPIO is reset.

RSTINTCLR - Clear NO Init/Power-On Interrupt Register
Table 43. RSTINTCLR - Clear NO Init/Power-On Interrupt Register

Register - Name	Address	Type	Register Function
RSTINTCLR	0x84	W	This register is used to clear the PORIRQ Interrupt. This interrupt is set every time the device returns from RESET (either POR, HW or SW Reset).
Bit - Name	Bit	Default	Bit Function
reserved	7:1		(reserved)
IRQCLR	0		1: Clears the PORIRQ Interrupt signalled in IRQST register. 0: is ignored

CLKMODE - Clock Mode Register
Table 44. CLKMODE - Clock Mode Register

Register - Name	Address	Type	Register Function
CLKMODE	0x88	R/W	This register controls the current operating mode of the LM8330 device.
Bit - Name	Bit	Default	Bit Function
(reserved)	7:2		(reserved)
MODCTL[1:0]	1:0	0x01	Writing to 00 forces the device to immediately enter sleep mode, regardless of any auto-sleep configuration. Reading this bit returns the current operating mode. NOTE: Any active PWM Outputs will be turned off when the LM8330 is transitioned from Operation Mode to Sleep Mode: 00: SLEEP Mode 01: Operation Mode 1x: Future modes

CLKEN - Clock Enable Register
Table 45. CLKEN - Clock Enable Register

Register - Name	Address	Type	Register Function
CLKEN	0x8A	R/W	Controls the clock to different functional units. It is used to enable the functional blocks globally and independently.
Bit - Name	Bit	Default	Bit Function
(reserved)	7:3		(reserved)
TIMEN	2	0x0	PWM Timer 0, 1, 2 clock enable: 0: Timer 0, 1, 2 clock disabled 1: Timer 0, 1, 2 clock enabled.
(reserved)	1		(reserved)
KBDEN	0	0x0	Keyboard clock enable (enables/disables key scan): 0: Keyboard clock disabled 1: Keyboard clock enabled

AUTOSLIP - Auto-sleep Enable Register
Table 46. AUTOSLIP - Auto-sleep Enable Register

Register - Name	Address	Type	Register Function
AUTOSLP	0x8B	R/W	This register controls the Auto-Sleep function of the LM8330 device.
Bit - Name	Bit	Default	Bit Function
(reserved)	7:1		(reserved)

Table 46. AUTOSLIP - Auto-sleep Enable Register (continued)

Register - Name	Address	Type	Register Function
ENABLE	0	0x00	Enables automatic sleep mode after a defined activity time stored in the AUTOSLPTI register: 1: Enable entering auto-sleep mode 0: Disable entering auto-sleep mode

AUTOSLPTI - Auto-Sleep Time Register**Table 47. AUTOSLPTI - Auto-Sleep Time Register**

Register - Name	Address	Type	Register Function
AUTOSLPTIL AUTOSLPTIH	0x8C 0x8D	R/W	This register defines the activity time. If this time passes without any processing events then the device enters into sleep-mode, but only if AUTOSLP.ENABLE bit is set to 1.
Bit - Name	Bit	Default	Bit Function
(reserved)	15:11		(reserved)
UPTIME[10:8] UPTIME[7:0]	10:8 7:0	0x00 0xFF	Values of UPTIME[10:0] match to multiples of 4ms: 0x00: no autosleep, regardless if AUTOSLP.ENABLE is set 0x01: 4ms 0x02: 8ms 0x7A: 500 ms 0xFF: 1020 ms (default after reset) 0x100: 1024 ms 0x7FF: 8188 ms

IRQST - Interrupt Global Interrupt Status Register**Table 48. IRQST - Interrupt Global Interrupt Status Register**

Register - Name	Address	Type	Register Function
IRQST	0x91	R	Returns the interrupt status from various on-chip function blocks. If any of the bits is set and an IRQN line is configured, the IRQN line is asserted active.
Bit - Name	Bit	Default	Bit Function
PORIRQ	7	0x1	Supply failure on VCC. Also power-on is considered as an initial supply failure. Therefore, after power-on, the bit is set: 0: no failure recorded 1: Failure - device was completely reset and requires re-programming.
KBDIRQ	6	0x0	Keyboard interrupt (further key selection in keyboard module): 0: inactive 1: active
(reserved)	5:4		(reserved)
TIM2IRQ	3	0x0	Timer2 expiry (CDIRQ or CYCIRQ): 0: inactive 1: active
TIM1IRQ	2	0x0	Timer1 expiry (CDIRQ or CYCIRQ): 0: inactive 1: active
TIM0IRQ	1	0x0	Timer0 expiry (CDIRQ or CYCIRQ): 0: inactive 1: active
GPIOIRQ	0	0x0	GPIO interrupt (further selection in GPIO module): 0: inactive 1: active

GPIO FEATURE CONFIGURATION

GPIO Feature Mapping

The LM8330 has a flexible I/O structure which allows flexibility in the assignment of different functionality to each ball. This flexibility is implemented in several registers that are used to configure the balls for function (Keypad Matrix, Dedicated Key, GPIO, PWM, or Interrupt). Each ball can also be configured for direction, internal pull resistor, and output buffer type (full, open drain, open source). The functionality of each ball is determined according to the following configuration priority:

In general the following priority is given:

1. Keypad
2. GPIO/PWM/Interrupt

Each ball that is configured as part of a Keypad Matrix or Dedicated Keypad input will automatically configure the ball direction, pull resistor and output buffer type. Any ball not configured as part of the keypad matrix will be available as GPIO, PWM or interrupt output (IRQN) and must be configured accordingly.

The configuration for Keypad, PGIO, PWM, or interrupt usages is defined by the following register priority:

- 1st Priority: KBDSIZE
- 2nd Priority: KBDEDCFG
- 3rd Priority: IOCFG
- 4th Priority: GPIODIR/GPIOME/GPIOMS/IOPC

When there is a conflict between any of these registers the ball will be configured according the priority above. Below are several example programming conflicts and the resulting configuration.

- If KBDSIZE selects 8x8 matrix, but KBDEDCFG selects KPX2 as a Dedicated Input Key, the KBDSIZE takes priority and the ball will be configured as a Keypad Matrix Input.
- If KBDSIZE selects 8x8 matrix, but IOPC selects KPX[7:0] pins to have no pullup resistor enabled, the KBDSIZE takes priority and the pullup resistors will automatically be enabled on all KPX[7:0] pins. Likewise, the KPY[7:0] pins will be automatically configured to have no pullup or pulldown resistor enabled irregardless of the settings in the IOPC registers since that behavior is required for Keyboard Matrix Outputs (i.e. KBDSIZE has priority).
- When there is a conflict between KBDSIZE settings and the GPIODIR, GPIOMS, or GPIOME settings, KBDSIZE takes priority and the pins selected as Keyboard Matrix pins are automatically configured into the proper direction, pullup/down configuration, and IO buffer configuration consistent with the required operation as matrix pins.
- If the IOCFG register selects a pin to be a PWM output, but the GPIODIR register selects the pin to be an input, the IOCFG register takes priority and the pin will behave as a PWM output.

Table 49. Ball Configuration Options

BALL	Module connectivity													
	GPIOSEL	BALLCFG							0x3	0x4	0x5	0x6	0x7	
		0x0	0x1	0x2	0x3	0x4	0x5	0x6						0x7
KPX[7:0]	X	Keypad Matrix or GPIO [7:0]							Reserved ⁽¹⁾					
KPY[7:0]	X	Keypad Matrix or GPIO [15:8]												
KPY8	0	KPY8/ GPIO16	KPY8/ GPIO16	-										
	1		PWM2 ⁽²⁾	-										
KPY9	X	KPY9/ GPIO17	PWM1	-										
KPY10	X	KPY10/ GPIO18	PWM0	-										
IRQN	0	KPY11/ GPIO19	PWM2 ⁽²⁾											
	1		IRQN											

(1) BALLCFG 0x3 thru 0x7 are invalid and can result in indeterminate behavior.

(2) PWM2 functionality is mutually exclusive — one pin at a time only (KPY8 or KPY11) depending on interrupt enable Bit 4 of IOCFG.

IOCGF - Input/Output Pin Mapping Configuration Register**Table 50. IOCGF - Input/Output Pin Mapping Configuration Register**

Register - Name	Address	Type	Register Function
IOCGF	0xA7	W	Configures usage of KPY[11:8] if not used for Keypad. (Refer to Table 49 for appropriate BALLCFG setting.)
Bit - Name	Bit	Default	Bit Function
(reserved)	7:5	(reserved, set to zero)	(reserved, set to zero)
GPIOSEL	4		Configures KPY11 as the IRQN output:
			1= IRQN enabled 0 = BALLCFG Mapping
(reserved)	3		(reserved, set to zero)
BALLCFG	2:0		Select column to configure — refer to Table 49 .

IOPC0 - Pull Resistor Configuration Register 0**Table 51. IOPC0 - Pull Resistor Configuration Register 0**

Register - Name	Address	Type	Register Function
IOPC0 ⁽¹⁾	0xAA	R/W	Defines the pull resistor configuration for balls KPX[7:0].
Bit - Name	Bit	Default	Bit Function
KPX7PR[1:0]	15:14	0x2	Resistor enable for KPX7 ball: 00: no pull resistor at ball 01: pulldown resistor programmed 1x: pullup resistor programmed
KPX6PR[1:0]	13:12	0x2	Resistor enable for KPX6 ball: 00: no pull resistor at ball 01: pulldown resistor programmed 1x: pullup resistor programmed
KPX5PR[1:0]	11:10	0x2	Resistor enable for KPX5 ball: 00: no pull resistor at ball 01: pulldown resistor programmed 1x: pullup resistor programmed
KPX4PR[1:0]	9:8	0x2	Resistor enable for KPX4 ball: 00: no pull resistor at ball 01: pulldown resistor programmed 1x: pullup resistor programmed
KPX3PR[1:0]	7:6	0x2	Resistor enable for KPX3 ball: 00: no pull resistor at ball 01: pulldown resistor programmed 1x: pullup resistor programmed
KPX2PR[1:0]	5:4	0x2	Resistor enable for KPX2 ball: 00: no pull resistor at ball 01: pulldown resistor programmed 1x: pullup resistor programmed
KPX1PR[1:0]	3:2	0x2	Resistor enable for KPX1 ball: 00: no pull resistor at ball 01: pulldown resistor programmed 1x: pullup resistor programmed

(1) Written values of 0x2 and 0x3 will always be read back as 0x3.

Table 51. IOPC0 - Pull Resistor Configuration Register 0 (continued)

Register - Name	Address	Type	Register Function
KPX0PR[1:0]	1:0	0x2	Resistor enable for KPX0 ball: 00: no pull resistor at ball 01: pulldown resistor programmed 1x: pullup resistor programmed

IOPC1 - Pull Resistor Configuration Register 1
Table 52. IOPC1 - Pull Resistor Configuration Register 1

Register - Name	Address	Type	Register Function
IOPC1 ⁽¹⁾	0xAC	R/W	Defines the pull resistor configuration for balls KPY[7:0].
Bit - Name	Bit	Default	Bit Function
KPY7PR[1:0]	15:14	0x1	Resistor enable for KPY7 ball: 00: no pull resistor at ball 01 :pulldown resistor programmed 1x: pullup resistor programmed
KPY6PR[1:0]	13:12	0x1	Resistor enable for KPY6 ball: 00: no pull resistor at ball 01: pulldown resistor programmed 1x: pullup resistor programmed
KPY5PR[1:0]	11:10	0x1	Resistor enable for KPY5 ball: 00: no pull resistor at ball 01: pulldown resistor programmed 1x: pullup resistor programmed
KPY4PR[1:0]	9:8	0x1	Resistor enable for KPY4 ball: 00: no pull resistor at ball 01: pulldown resistor programmed 1x: pullup resistor programmed
KPY3PR[1:0]	7:6	0x1	Resistor enable for KPY3 ball: 00: no pull resistor at ball 01: pulldown resistor programmed 1x: pullup resistor programmed
KPY2PR[1:0]	5:4	0x1	Resistor enable for KPY2 ball: 00: no pull resistor at ball 01: pulldown resistor programmed 1x: pullup resistor programmed
KPY1PR[1:0]	3:2	0x1	Resistor enable for KPY1 ball: 00: no pull resistor at ball 01: pulldown resistor programmed 1x: pullup resistor programmed
KPY0PR[1:0]	1:0	0x1	Resistor enable for KPY0 ball: 00: no pull resistor at ball 01: pulldown resistor programmed 1x: pullup resistor programmed

(1) Written values of 0x2 and 0x3 will always be read back as 0x3.

IOPC2 - Pull Resistor Configuration Register 2**Table 53. IOPC2 - Pull Resistor Configuration Register 2**

Register - Name	Address	Type	Register Function
IOPC2 ⁽¹⁾	0xAE	R/W	Defines the pull resistor configuration for balls KPY[11:8].
Bit - Name	Bit	Default	Bit Function
(reserved)	15:8	0x5A	(reserved)
KPY11PR[1:0]	7:6	0x0	Resistor enable for KPY11 ball: 00: no pull resistor at ball 01: pulldown resistor programmed 1x: pullup resistor programmed
KPY10PR[1:0]	5:4	0x1	Resistor enable for KPY10 ball: 00: no pull resistor at ball 01 pulldown resistor programmed 1x: pullup resistor programmed
KPY9PR[1:0]	3:2	0x1	Resistor enable for KPY9 ball: 00: no pull resistor at ball 01: pulldown resistor programmed 1x: pullup resistor programmed
KPY8PR[1:0]	1:0	0x1	Resistor enable for KPY8 ball: 00: no pull resistor at ball 01: pulldown resistor programmed 1x: pullup resistor programmed

(1) Written values of 0x2 and 0x3 will always be read back as 0x3.

GPIOOME0 - GPIO Open Drain Mode Enable Register 0**Table 54. GPIOOME0 - GPIO Open Drain Mode Enable Register 0**

Register - Name	Address	Type	Register Function
GPIOOME0	0xE0	R/W	Configures KPX[7:0] for Open Drain or standard output functionality. The Open Drain drive source is configured by GPIOOMS0.
Bit - Name	Bit	Default	Bit Function
KPX[7:0]ODE	7:0	0x0	Open Drain Enable on KPX[7:0]: 0: full buffer 1: open drain functionality

GPIOOMS0 - GPIO Open Drain Mode Select Register 0**Table 55. GPIOOMS0 - GPIO Open Drain Mode Select Register 0**

Register - Name	Address	Type	Register Function
GPIOOMS0	0xE1	R/W	Configures the Open Drain drive source on KPX[7:0] if selected by GPIOOME0.
Bit - Name	Bit	Default	Bit Function
KPX[7:0]ODM	7:0	0x0	0: Only nmos transistor is active in output driver stage. Output can be driven to GND or Hi-Z. 1: Only pmos transistor is active in output driver stage. Output can be driven to VCC or Hi-Z.

GPIOOME1 - GPIO Open Drain Mode Enable Register 1
Table 56. GPIOOME1 - GPIO Open Drain Mode Enable Register 1

Register - Name	Address	Type	Register Function
GPIOOME1	0xE2	R/W	Configures KPY[7:0] for Open Drain or standard output functionality. The Open Drain drive source is configured by GPIOOMS1.
Bit - Name	Bit	Default	Bit Function
KPY[7:0]ODE	7:0	0x0	Open Drain Enable on KPY[7:0] 0: full buffer 1: open drain functionality

GPIOOMS1 - GPIO Open Drain Mode Select Register 1
Table 57. GPIOOMS1 - GPIO Open Drain Mode Select Register 1

Register - Name	Address	Type	Register Function
GPIOOMS1	0xE3	R/W	Configures the Open Drain drive source on KPY[7:0] if selected by GPIOOME1.
Bit - Name	Bit	Default	Bit Function
KPY[7:0]ODM	7:0	0x0	0: Only nmos transistor is active in output driver stage. Output can be driven to GND or Hi-Z. 1: Only pmos transistor is active in output driver stage. Output can be driven to VCC or Hi-Z.

GPIOOME2 - GPIO Open Drain Mode Enable Register 2
Table 58. GPIOOME2 - GPIO Open Drain Mode Enable Register 2

Register - Name	Address	Type	Register Function
GPIOOME2	0xE4	R/W	Configures KPY[11:8] for Open Drain or standard output functionality. The Open Drain drive source is configured by GPIOOMS2.
Bit - Name	Bit	Default	Bit Function
(reserved)	7:4	0x0	(reserved)
KPY[11:8]ODE	3:0	0x8	Open Drain Enable on KPY[11:8]: 0: full buffer 1: open drain functionality Note: IRQN ball defaults to Open Drain Mode Enable after reset.

GPIOOMS2 - GPIO Open Drain Mode Select Register 2
Table 59. GPIOOMS2 - GPIO Open Drain Mode Select Register 2

Register - Name	Address	Type	Register Function
GPIOOMS2	0xE5	R/W	Configures the Open Drain drive source on KPY[11:8] if selected by GPIOOME2.
Bit - Name	Bit	Default	Bit Function
(reserved)	7:4		(reserved)
KPY[11:8]ODM	3:0	0x0	0: Only nmos transistor is active in output driver stage. Output can be driven to GND or Hi-Z. 1: Only pmos transistor is active in output driver stage. Output can be driven to VCC or Hi-Z.

GPIO DATA INPUT/OUTPUT

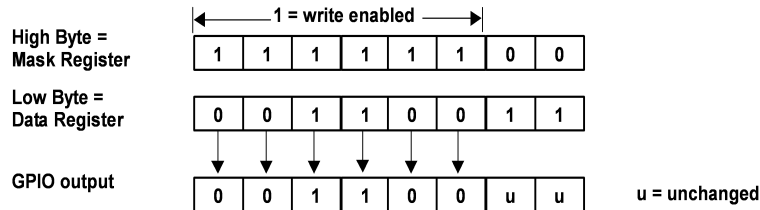

GPIO DATA REGISTER 0

Table 60. GPIO DATA REGISTER 0

Register - Name	Address	Type	Register Function
GPIO DATA0	0xC0	R/W	This register controls GPIO Data & Mask on KPX[7:0]. If one I/O is defined as output (see Table 63), the values written to this register are masked with MASK and then applied to the associated pin. Any I/O defined as an input (see Table 63) will return the value of the associated pin regardless of the MASK value when read.
Bit - Name	Bit	Default	Bit Function
KPX[7:0]MASK	15:8	0x0	Mask Bits for KPX[7:0] when configured as GPIO Output: 1: output is not masked 0: output is masked (unchanged)
KPX[7:0]	7:0	0xFC	KPX[7:0] Pin State when configured as GPIO: WRITE: Pin State = DATA if not Masked READ: DATA = Current Pin State

GPIO DATA REGISTER 1

Table 61. GPIO DATA REGISTER 1

Register - Name	Address	Type	Register Function
GPIO DATA1	0xC2	R/W	This register controls GPIO Data & Mask on KPY[7:0]. If any I/O is defined as output (see Table 64), the value written to this register are masked with MASK and then applied to the associated pin. Any I/O defined as an input (see Table 64) will return the value of the associated pin regardless of the MASK value when read.
Bit - Name	Bit	Default	Bit Function
KPY[7:0]MASK	15:8	0x0	Mask Bits for KPY[7:0] when configured as GPIO Output: 1: output is not masked 0: output is masked (unchanged)
KPY[7:0]	7:0	0x00	KPY[7:0] Pin State when configured as GPIO: WRITE: Pin State = DATA if not Masked READ: DATA = Current Pin State

GPIO DATA REGISTER 2

Table 62. GPIO DATA REGISTER 2

Register - Name	Address	Type	Register Function
GPIO DATA2	0xC4	R/W	This register controls GPIO Data & Mask on KPY[11:8]. If any I/O is defined as an output (see Table 65) the value written to this register is masked with MASK and then applied to the associated pin. Any I/O defined as an input (see Table 65) will return the value of the associated pin regardless of the MASK value when read.
Bit - Name	Bit	Default	Bit Function

Table 62. GPIODATA2 - GPIO Data Register 2 (continued)

Register - Name	Address	Type	Register Function
(reserved)	15:12	0x0	(reserved)
KPY[11:8]	11:8	0x0	Mask Status for KPYPY[11:8] when enabled as GPIO: 1: Output is not masked 0: Output is masked.
reserved	7:4	0x0	(reserved)
KPY[11:8]DATA	3:0	0x0	KPY [11:8] Pin State when configured as GPIO : WRITE: Pin State = DATA if not Masked READ: DATA = Current Pin State

GPIODIR0 - GPIO Port Direction Register 0
Table 63. GPIODIR0 - GPIO Port Direction Register 0

Register - Name	Address	Type	Register Function
GPIODIR0	0xC6	R/W	Port direction for KPXPY[7:0].
Bit - Name	Bit	Default	Bit Function
KPXPY[7:0]DIR	7:0	0x00	Direction bits for KPXPY[7:0]: 0: input mode 1: output mode

GPIODIR1 - GPIO Port Direction Register 1
Table 64. GPIODIR1 - GPIO Port Direction Register 1

Register - Name	Address	Type	Register Function
GPIODIR1	0xC7	R/W	Port direction for KPYPY[7:0]
Bit - Name	Bit	Default	Bit Function
KPYPY[7:0]DIR	7:0	0x00	Direction bits for KPYPY[7:0]: 0: input mode 1: output mode

GPIODIR2 - GPIO Port Direction Register 2
Table 65. GPIODIR2 - GPIO Port Direction Register 2

Register - Name	Address	Type	Register Function
GPIODIR2	0xC8	R/W	Port direction for KPYPY[11:8]:
Bit - Name	Bit	Default	Bit Function
(reserved)	7:4		(reserved)
KPYPY[11:8]DIR	3:0	0x08	Direction bits for KPYPY[11:8] 0: input mode 1: output mode

GPIO INTERRUPT CONTROL
GPIOIS0 - Interrupt Sense Configuration Register 0
Table 66. GPIOIS0 - Interrupt Sense Configuration Register 0

Register - Name	Address	Type	Register Function
GPIOIS0	0xC9	R/W	Interrupt type on KPXPY[7:0].
Bit - Name	Bit	Default	Bit Function

Table 66. GPIOIS0 - Interrupt Sense Configuration Register 0 (continued)

Register - Name	Address	Type	Register Function
KPX[7:0]IS	7:0	0x0	Interrupt type bits for KPX[7:0]: 0: edge sensitive interrupt 1: level sensitive interrupt

GPIOIS1 - Interrupt Sense Configuration Register 1**Table 67. GPIOIS1 - Interrupt Sense Configuration Register 1**

Register - Name	Address	Type	Register Function
GPIOIS1	0xCA	R/W	Interrupt type on KPY[7:0]
Bit - Name	Bit	Default	Bit Function
KPY[7:0]IS	7:0	0x0	Interrupt type bits for KPY[7:0]: 0: edge sensitive interrupt 1: level sensitive interrupt

GPIOIS2 - Interrupt Sense Configuration Register 2**Table 68. GPIOIS2 - Interrupt Sense Configuration Register 2**

Register - Name	Address	Type	Register Function
GPIOIS2	0xCB	R/W	Interrupt type on KPY[11:8]
Bit - Name	Bit	Default	Bit Function
(reserved)	7:4		(reserved)
KPY[11:8]IS	3:0	0x0	Interrupt type bits for KPY[11:8]: 0: edge sensitive interrupt 1: level sensitive interrupt

GPIOIBE0 - GPIO Interrupt Edge Configuration Register 0**Table 69. GPIOIBE0 - GPIO Interrupt Edge Configuration Register 0**

Register - Name	Address	Type	Register Function
GPIOIBE0	0xCC	R/W	Defines whether an interrupt on KPX[7:0] is triggered on either edge or on a single edge. See Table 72 for the edge configuration.
Bit - Name	Bit	Default	Bit Function
KPX[7:0]IBE	7:0	0x0	Interrupt both edges bits for KPX[7:0]: 0: interrupt generated at the active edge 1: interrupt generated after either edge.

GPIOIBE1 - GPIO Interrupt Edge Configuration Register 1**Table 70. GPIOIBE1 - GPIO Interrupt Edge Configuration Register 1**

Register - Name	Address	Type	Register Function
GPIOIBE1	0xCD	R/W	Defines whether an interrupt on KPY[7:0] is triggered on either edge or on a single edge. See Table 73 for the edge configuration.
Bit - Name	Bit	Default	Bit Function
KPY[7:0]IBE	7:0	0x0	Interrupt both edges bits for KPY[7:0]: 0: interrupt generated at the active edge. 1: interrupt generated after either edge.

GPIOBE2 - GPIO Interrupt Edge Configuration Register 2
Table 71. GPIOBE2 - GPIO Interrupt Edge Configuration Register 2

Register - Name	Address	Type	Register Function
GPIOBE2	0xCE	R/W	Defines whether an interrupt on KPY[11:8] was triggered on either edge or on a single edge. See Table 74 for the edge configuration.
Bit - Name	Bit	Default	Bit Function
(reserved)	7:4		(reserved)
KPY[11:8]IBE	3:0	0x0	Interrupt both edges bits for KPY[11:8]: 0: interrupt generated at the active edge. 1: interrupt generated after either edge.

GPIOIEV0 - GPIO Interrupt Edge Select Register 0
Table 72. GPIOIEV0 - GPIO Interrupt Edge Select Register 0

Register - Name	Address	Type	Register Function
GPIOIEV0	0xCF	R/W	Select Interrupt edge for KPX[7:0].
Bit - Name	Bit	Default	Bit Function
KPX[7:0]EV	7:0	0xFF	Interrupt edge select from KPX[7:0]: 0: interrupt at low level or falling edge 1: interrupt at high level or rising edge

GPIOIEV1 - GPIO Interrupt Edge Select Register 1
Table 73. GPIOIEV1 - GPIO Interrupt Edge Select Register 1

Register - Name	Address	Type	Register Function
GPIOIEV1	0xD0	R/W	Select Interrupt edge for KPY[7:0].
Bit - Name	Bit	Default	Bit Function
KPY[7:0]EV	7:0	0xFF	Interrupt edge select from KPY[7:0]: 0: interrupt at low level or falling edge 1: interrupt at high level or rising edge

GPIOIEV2 - GPIO Interrupt Edge Select Register 2
Table 74. GPIOIEV2 - GPIO Interrupt Edge Select Register 2

Register - Name	Address	Type	Register Function
GPIOIEV2	0xD1	R/W	Select Interrupt edge for KPY[11:8].
Bit - Name	Bit	Default	Bit Function
(reserved)	7:4		(reserved)
KPY[11:8]EV	3:0	0xFF	Interrupt edge select from KPY[11:8]: 0: interrupt at low level or falling edge 1: interrupt at high level or rising edge

GPIOIE0 - GPIO Interrupt Enable Register 0
Table 75. GPIOIE0 - GPIO Interrupt Enable Register 0

Register - Name	Address	Type	Register Function
GPIOIE0	0xD2	R/W	Enable/disable interrupts on KPX[7:0].
Bit - Name	Bit	Default	Bit Function

Table 75. GPIOIE0 - GPIO Interrupt Enable Register 0 (continued)

Register - Name	Address	Type	Register Function
KPX[7:0]IE	7:0	0x0	Interrupt enable on KPX[7:0]: 0: disable interrupt 1: enable interrupt

GPIOIE1 - GPIO Interrupt Enable Register 1**Table 76. GPIOIE1 - GPIO Interrupt Enable Register 1**

Register - Name	Address	Type	Register Function
GPIOIE1	0xD3	R/W	Enable/disable interrupts on KPY[7:0].
Bit - Name	Bit	Default	Bit Function
KPY[7:0]IE	7:0	0x0	Interrupt enable on KPY[7:0]: 0: disable interrupt 1: enable interrupt

GPIOIE2 - GPIO Interrupt Enable Register 2**Table 77. GPIOIE2 - GPIO Interrupt Enable Register 2**

Register - Name	Address	Type	Register Function
GPIOIE2	0xD4	R/W	Enable/disable interrupts on KPY[11:8].
Bit - Name	Bit	Default	Bit Function
(reserved)	7:4		(reserved)
KPY[11:8]IE	3:0	0x0	Interrupt enable on KPY[11:8]: 0: disable interrupt 1: enable interrupt

GPIOIC0 - GPIO Clear Interrupt Register 0**Table 78. GPIOIC0 - GPIO Clear Interrupt Register 0**

Register - Name	Address	Type	Register Function
GPIOIC0	0xDC	W	Clears the interrupt on KPX[7:0].
Bit - Name	Bit	Default	Bit Function
KPX[7:0]IC	7:0		Clear Interrupt on KPX[7:0]: 0: no effect 1: Clear corresponding interrupt

GPIOIC1 - GPIO Clear Interrupt Register 1**Table 79. GPIOIC1 - GPIO Clear Interrupt Register 1**

Register - Name	Address	Type	Register Function
GPIOIC1	0xDD	W	Clears the interrupt on KPY[7:0].
Bit - Name	Bit	Default	Bit Function
KPY[7:0]IC	7:0		Clear Interrupt on KPY[7:0]: 0: no effect 1: Clear corresponding interrupt

GPIOIC2 - GPIO Clear Interrupt Register 2
Table 80. GPIOIC2 - GPIO Clear Interrupt Register 2

Register - Name	Address	Type	Register Function
GPIOIC2	0xDE	W	Clears the interrupt on KPY[11:8].
Bit - Name	Bit	Default	Bit Function
(reserved)	7:4		(reserved)
KPY[11:8]IC	3:0		Clear Interrupt on KPY[11:8]: 0: no effect 1: Clear corresponding interrupt

GPIO INTERRUPT STATUS
GPIORIS0 - Raw Interrupt Status Register 0
Table 81. GPIORIS0 - Raw Interrupt Status Register 0

Register - Name	Address	Type	Register Function
GPIORIS0	0xD6	R	Raw interrupt status on KPX[7:0]
Bit - Name	Bit	Default	Bit Function
KPX[7:0]RIS	7:0	0x0	Raw Interrupt status data on KPX[7:0]: 0: no interrupt condition at GPIO 1: interrupt condition at GPIO

GPIORIS1 - Raw Interrupt Status Register 1
Table 82. GPIORIS1 - Raw Interrupt Status Register 1

Register - Name	Address	Type	Register Function
GPIORIS1	0xD7	R	Raw interrupt status on KPY[7:0].
Bit - Name	Bit	Default	Bit Function
KPY[7:0]RIS	7:0	0x0	Raw Interrupt status data on KPY[7:0]: 0: no interrupt condition at GPIO 1: interrupt condition at GPIO

GPIORIS2 - Raw Interrupt Status Register 2
Table 83. GPIORIS2 - Raw Interrupt Status Register 2

Register - Name	Address	Type	Register Function
GPIORIS2	0xD8	R	Raw interrupt status on KPY[11:8].
Bit - Name	Bit	Default	Bit Function
(reserved)	7:4		(reserved)
KPY[11:8]RIS	3:0	0x0	Raw Interrupt status data on KPY[11:8]: 0: no interrupt condition at GPIO 1: interrupt condition at GPIO

GPIOMIS0 - Masked Interrupt Status Register 0
Table 84. GPIOMIS0 - Masked Interrupt Status Register 0

Register - Name	Address	Type	Register Function
GPIOMIS0	0xD9	R	Masked interrupt status on KPX[7:0].
Bit - Name	Bit	Default	Bit Function

Table 84. GPIOMIS0 - Masked Interrupt Status Register 0 (continued)

Register - Name	Address	Type	Register Function
KPX[7:0]MIS	7:0	0x0	Masked Interrupt status data on KPX[7:0]: 0: no interrupt contribution from GPIO 1: interrupt GPIO is active

GPIOMIS1 - Masked Interrupt Status Register 1**Table 85. GPIOMIS1 - Masked Interrupt Status Register 1**

Register - Name	Address	Type	Register Function
GPIOMIS1	0xDA	R	Masked interrupt status on KPY[7:0].
Bit - Name	Bit	Default	Bit Function
KPY[7:0]MIS	7:0	0x0	Masked Interrupt status data on KPY[7:0]: 0: no interrupt contribution from GPIO 1: interrupt GPIO is active

GPIOMIS2 - Masked Interrupt Status Register 2**Table 86. GPIOMIS2 - Masked Interrupt Status Register 2**

Register - Name	Address	Type	Register Function
GPIOMIS2	0xDB	R	Masked interrupt status on KPY[11:8].
Bit - Name	Bit	Default	Bit Function
(reserved)	7:4		(reserved)
KPY[11:8]MIS	3:0	0x0	Masked Interrupt status data on KPY[11:8]: 0: no interrupt contribution from GPIO 1: interrupt GPIO is active

GPIO WAKE-UP CONTROL**GPIOWAKE0 - GPIO Wake-Up Register 0****Table 87. GPIOWAKE0 - GPIO Wake-Up Register 0**

Register - Name	Address	Type	Register Function
GPIOWAKE0	0xE9	R/W	Configures wake-up conditions for KPX[7:0]. Each bit corresponds to a ball. When a bit is set, the corresponding ball contributes to wakeup from auto-sleep mode.
Bit - Name	Bit	Default	Bit Function
KPX[7:0]WAKE	7:0	0x0	Wake up from auto sleep on KPY[7:0] 0: wake up from auto sleep disabled 1: wake up from auto sleep enabled

GPIOWAKE1 - GPIO Wake-Up Register 1**Table 88. GPIOWAKE1 - GPIO Wake-Up Register 1**

Register - Name	Address	Type	Register Function
GPIOWAKE1	0xEA	R/W	Configures wake-up conditions for KPY[7:0]. Each bit corresponds to a ball. When a bit is set, the corresponding ball contributes to wakeup from auto-sleep mode.
Bit - Name	Bit	Default	Bit Function
KPY[7:0]WAKE	7:0	0x0	Wake up from Auto sleep on KPY[7:0] 0: wake up from auto sleep disabled 1: wake up from auto sleep enabled

GPIOWAKE2 - GPIO Wake-Up Register 2
Table 89. GPIOWAKE2 - GPIO Wake-Up Register 2

Register - Name	Address	Type	Register Function
GPIOWAKE2	0xEB	R/W	Configures wake-up conditions for KPY[11:8]. Each bit corresponds to a ball. When a bit is set, the corresponding ball contributes to wakeup from auto-sleep mode.
Bit - Name	Bit	Default	Bit Function
(reserved)	7:4		(reserved)
KPY[11:8]WAKE	3:0	0x0	Wake up from auto sleep on KPY[11:8] 0: wake up from auto sleep disabled 1: wake up from auto sleep enabled

REGISTERS
REGISTER MAPPING

Registers defined as word access size must have both the lower and upper bytes written in one ACCESS.Bus cycle before the internal register will be updated. If these registers are written as separate bytes, the value will be discarded, and the internal register will be unchanged. Registers defined as byte access can be written individually.

Keyboard Registers

shows the register map for keyboard functionality. In addition to RESET_N,POR or Software Reset using SWRESET (see [Table 41](#)) or Software Reset using SWRESET (see [Table 41](#)), these registers are reset to default values by a module reset using RSTCTRL.KBDRST and should be rewritten for desired settings (see [Table 42](#)).

Register Map for Keyboard Functionality

Register Name	Description	Register File Address	Register Type	ACCESS Size	Default value	Next RF Address
KBDSETTLE	Keypad Settle Time	0x01	R/W	byte	0x80	0x02
KBDBOUNCE	Keypad Debounce Time	0x02	R/W	byte	0x80	0x03
KBDSIZE	Keypad Size Configuration	0x03	R/W	byte	0x22	0x04
KBDEDCFG0	Keypad Dedicated Key 0	0x04	R/W	byte	0xFF	0x05
KBDEDCFG1	Keypad Dedicated Key 1	0x05	R/W	byte	0xFF	0x06
KBDRIS	Keypad Raw Interrupt Status	0x06	R	byte	0x00	0x07
KBDMIS	Keypad Masked Interrupt Status	0x07	R	byte	0x00	0x08
KBDIC	Keypad Interrupt Clear	0x08	W	byte		0x09
KBDMSK	Keypad Interrupt Mask	0x09	R/W	byte	0x03	0x0A
KBDCODE0	Keypad Code 0	0x0B	R	byte	0x7F	0x0C
KBDCODE1	Keypad Code 1	0x0C	R	byte	0x7F	0x0D
KBDCODE2	Keypad Code 2	0x0D	R	byte	0x7F	0x0E
KBDCODE3	Keypad Code 3	0x0E	R	byte	0x7F	0x0F
EVTCODE	Key Event Code	0x10	R	byte	0x7F	0x10

PWM Timer Registers

shows the register map for PWM Timer functionality. In addition to RESET_N, POR and software reset using SWRESET (see [Table 41](#)), these registers are reset to default values by a module reset using RSTCTRL.TIMRST (see [RSTCTRL - System Reset Register](#)).

Register Map for PWM Timer Functionality

Register Name	Description	Register File Address	Register Type	ACCESS Size	Default value	Next RF Address
TIMCFG0	PWM Timer Configuration 0	0x60	R/W	byte	0x00	0x61
PWMCFG0	PWM Configuration 0	0x61	R/W	byte	0x00	0x62
TIMCFG1	PWM Timer Configuration 1	0x68	R/W	byte	0x00	0x69
PWMCFG1	PWM Configuration 1	0x69	R/W	byte	0x00	0x6A
TIMCFG2	PWM Timer Configuration 2	0x70	R/W	byte	0x00	0x71
PWMCFG2	PWM Configuration 2	0x71	R/W	byte	0x00	0x72
TIMSWRES	PWM Timer SW Reset	0x78	W	byte		0x79
TIMRIS	PWM Timer Interrupt Status	0x7A	R	byte	0x00	0x7B
TIMMIS	PWM Timer Masked Int. Status	0x7B	R	byte	0x00	0x7C
TIMIC	Timer Interrupt Clear	0x7C	W	byte		0x7D
PWMWP	PWM Command Write Pointer	0x7D	R/W	byte	0x00	0x7E
PWMCFG	PWM Command Script	0x7E	W	word		0x7F

System Registers

shows the register map for general system registers. These registers are not affected by any of the module resets addressed by RSTCTRL (see [Table 42](#)). These registers can only be reset to default values by a Global Call Reset (see [GENERAL CALL RESET](#)) or by a complete Software Reset using SWRESET (see [Table 41](#)).

Register Map for System Control Functionality

Register Name	Description	Register File Address	Register Type	ACCESS Size	Default value	Next RF Address
I ² CSA	I ² C-compatible ACCESS.bus Slave Address	0x80	W	byte	0x88	0x81
MFGCODE	Manufacturer Code	0x80	R	byte	0x00	0x81
SWREV	SW Revision	0x81	R	byte	0x84	0x82
SWRESET	SW Reset	0x81	W	byte		0x82
RSTCTRL	System Reset	0x82	R/W	byte	0x00	0x83
RSTINTCLR	Clear No Init/Power On Interrupt	0x84	W	byte		0x85
CLKMODE	Clock Mode	0x88	R/W	byte	0x00	0x89
CLKEN	Clock Enable	0x8A	R/W	byte	0x00	0x8B
AUTOSLP	Auto-Sleep Enable	0x8B	R/W	byte	0x00	0x8C
AUTOSLPTI	Auto-Sleep Time	0x8C	R/W	word	0x00FF	0x8D

Global Interrupt Registers

shows the register map for global interrupt functionality. This register is reset to the default value by RESET_N, POR or Software Reset using SWRESET (see [Table 41](#)). This register is not affected by a module reset using RSTCTRL.IRQRST (see [Table 42](#)). Any interrupt that occurs while RSTCTRL.IRQRST is active will still be captured.

Register Map for Global Interrupt Functionality

Register Name	Description	Register File Address	Register Type	ACCESS Size	Default value	Next RF Address
IRQST	Global Interrupt Status	0x91	R	byte	0x80	0x92

GPIO Registers

shows the register map for GPIO functionality. In addition to RESET_N, POR and software reset using SWRESET (see [Table 41](#)), these registers are reset to default values by a module reset using RSTCTRL.GPIRST (see [Table 42](#)).

Register Map for GPIO Functionality

Register Name	Description	Register File Address	Register Type	ACCESS Size	Default value	Next RF Address
IOCFG	I/O Pin Mapping Configuration	0xA7	W	byte		0xA8
IOPC0	Pull Resistor Configuration 0	0xAA	R/W	word	0xAAAA	0xAB
IOPC1	Pull Resistor Configuration 1	0xAC	R/W	word	0x5555	0xAD
IOPC2	Pull Resistor Configuration 2	0xAE	R/W	word	0x5A15	0xAF
GPIODATA0	GPIO I/O Data 0	0xC0	R/W	byte	0xFC	0xC1
GIPIOMASK0	GPIO I/O Mask 0	0xC1	W	byte		0xC2
GPIODATA1	GPIO I/O Data 1	0xC2	R/W	byte	0x00	0xC3
GIPIOMASK1	GPIO I/O Mask 1	0xC3	W	byte		0xC4
GPIODATA2	GPIO I/O Data 2	0xC4	R/W	byte	0x00	0xC5
GIPIOMASK2	GPIO I/O Mask 2	0xC5	W	byte		0xC6
GPIODIR0	GPIO I/O Direction 0	0xC6	R/W	byte	0x00	0xC7
GPIODIR1	GPIO I/O Direction 1	0xC7	R/W	byte	0x00	0xC8
GPIODIR2	GPIO I/O Direction 2	0xC8	R/W	byte	0x08	0xC9
GPIOIS0	GPIO Int Sense Config 0	0xC9	R/W	byte	0x00	0xCA
GPIOIS1	GPIO Int Sense Config 1	0xCA	R/W	byte	0x00	0xCB
GPIOIS2	GPIO Int Sense Config 2	0xCB	R/W	byte	0x00	0xCC
GPIOIBE0	GPIO Int Both Edges Config 0	0xCC	R/W	byte	0x00	0xCD
GPIOIBE1	GPIO Int Both Edges Config 1	0xCD	R/W	byte	0x00	0xCE
GPIOIBE2	GPIO Int Both Edges Config 2	0xCE	R/W	byte	0x00	0xCF
GPIOIEV0	GPIO Int Edge Select 0	0xCF	R/W	byte	0xFF	0xD0
GPIOIEV1	GPIO Int Edge Select 1	0xD0	R/W	byte	0xFF	0xD1

Register Map for GPIO Functionality (continued)

Register Name	Description	Register File Address	Register Type	ACCESS Size	Default value	Next RF Address
GPIOIEV2	GPIO Int Edge Select 2	0xD1	R/W	byte	0x0F	0xD2
GPIOIE0	GPIO Interrupt Enable 0	0xD2	R/W	byte	0x00	0xD3
GPIOIE1	GPIO Interrupt Enable 1	0xD3	R/W	byte	0x00	0xD4
GPIOIE2	GPIO Interrupt Enable 2	0xD4	R/W	byte	0x00	0xD5
GPIO RIS0	GPIO Raw Int Status 0	0xD6	R	byte	0x00	0xD7
GPIO RIS1	GPIO Raw Int Status 1	0xD7	R	byte	0x00	0xD8
GPIO RIS2	GPIO Raw Int Status 2	0xD8	R	byte	0x00	0xD9
GPIO MIS0	GPIO Masked Int Status 0	0xD9	R	byte	0x00	0xDA
GPIO MIS1	GPIO Masked Int Status 1	0xDA	R	byte	0x00	0xDB
GPIO MIS2	GPIO Masked Int Status 2	0xDB	R	byte	0x00	0xDC
GPIO IC0	GPIO Interrupt Clear 0	0xDC	W	byte		0xDD
GPIO IC1	GPIO Interrupt Clear 1	0xDD	W	byte		0xDE
GPIO IC2	GPIO Interrupt Clear 2	0xDE	W	byte		0xDF
GPIO OME0	GPIO Open Drain Mode Enable 0	0xE0	R/W	byte	0x00	0xE1
GPIO OMS0	GPIO Open Drain Mode Select 0	0xE1	R/W	byte	0x00	0xE2
GPIO OME1	GPIO Open Drain Mode Enable 1	0xE2	R/W	byte	0x00	0xE3
GPIO OMS1	GPIO Open Drain Mode Select 1	0xE3	R/W	byte	0x00	0xE4
GPIO OME2	GPIO Open Drain Mode Enable 2	0xE4	R/W	byte	0x08	0xE5
GPIO OMS2	GPIO Open Drain Mode Select 2	0xE5	R/W	byte	0x00	0xE6
GPIO WAKE0	GPIO Wakeup Enable 0	0xE9	R/W	byte	0x00	0xEA
GPIO WAKE1	GPIO Wakeup Enable 1	0xEA	R/W	byte	0x00	0xEB
GPIO WAKE2	GPIO Wakeup Enable 2	0xEB	R/W	byte	0x00	0xEC

REGISTER LAYOUT - Control Bits in LM8330 Registers

Register	Addr.	BIT 7	BIT 6	BIT 5	BIT 4	BIT 3	BIT 2	BIT 1	BIT 0
KBDSETTLE	0x01	Wait[7:0]							
KBDBOUNCE	0x02	Wait[7:0]							
KBDSIZE	0x03	ROW-SIZE3	ROW-SIZE2	ROW-SIZE1	ROW-SIZE0	COL-SIZE3	COL-SIZE2	COL-SIZE1	COL-SIZE0
KBDEDCFG0	0x04	COL9	COL8	COL7	COL6	COL5	COL4	COL3	COL2
KBDEDCFG1	0x05	ROW7	ROW6	ROW5	ROW4	ROW3	ROW2	COL11	COL10
KBDRIS	0x06					RELINT	REVTINT	RKLINT	RSINT

REGISTER LAYOUT - Control Bits in LM8330 Registers (continued)

Register	Addr.	BIT 7	BIT 6	BIT 5	BIT 4	BIT 3	BIT 2	BIT 1	BIT 0
KBDMIS	0x07					MELINT	MEVTINT	MKLINT	MSINT
KBDIC	0x08	SFOFF						EVTIC	KBDIC
KBDMSK	0x09					MSKELINT	MSKEINT	MSKLINT	MSKSINT
KBDCODE0	0x0B	MULTIKEY	KEYROW2	KEYROW1	KEYROW0	KEYCOL3	KEYCOL2	KEYCOL1	KEYCOL0
KBDCODE1	0x0C	MULTIKEY	KEYROW2	KEYROW1	KEYROW0	KEYCOL3	KEYCOL2	KEYCOL1	KEYCOL0
KBDCODE2	0x0D	MULTIKEY	KEYROW2	KEYROW1	KEYROW0	KEYCOL3	KEYCOL2	KEYCOL1	KEYCOL0
KBDCODE3	0x0E	MULTIKEY	KEYROW2	KEYROW1	KEYROW0	KEYCOL3	KEYCOL2	KEYCOL1	KEYCOL0
EVTCODE	0x10	RELEASE	KEYROW2	KEYROW1	KEYROW0	KEYCOL3	KEYCOL2	KEYCOL1	KEYCOL0
TIMCFG0	0x60				CYCIRQ0-MASK				START
PWMCFG0	0x61					CDIRQ0-MASK	PGE	PWMEN	PWMPOL
TIMCFG1	0x68				CYCIRQ1-MASK				START
PWMCFG1	0x69					CDIRQ1-MASK	PGE	PWMEN	PWMPOL
TIMCFG2	0x70				CYCIRQ2-MASK				START
PWMCFG2	0x71					CDIRQ2-MASK	PGE	PWMEN	PWMPOL
TIMSWRES	0x78						SWRES2	SWRES1	SWRES0
TIMRIS	0x7A			CDIRQ2	CDIRQ1	CDIRQ0	CICIRQ2	CICIRQ1	CICIRQ0
TIMMIS	0x7B			CDIRQ2	CDIRQ1	CDIRQ0	CICIRQ2	CICIRQ1	CICIRQ0
TIMIC	0x7C			CDIRQ2	CDIRQ1	CDIRQ0	CICIRQ2	CICIRQ1	CICIRQ0
PWMWP	0x7D	0	PWMWP[6:0]						
PWMCFG(Low)	0x7E	CMD[7:0]							
PWMCFG(High)	0x7F	CMD[15:8]							
I ² CSA	0x80	SLAVEADDR[7:1]							0
MFGCODE	0x80	MFGBIT[7:0]							
SWREV	0x81	SWBIT[7:0]							
SWRESET	0x81	SWBIT[7:0]							
RSTCTRL	0x82				IRQRST	TIMRST		KBDRST	GPIRST
RSTINTCLR	0x84								IRQCLR
CLKMODE	0x88							MOD-CTL[1:0]	
CLKEN	0x8A						TIMEN		KBDEN
AUTOSLP	0x8B								ENABLE
AUTOSLPTI (Low)	0x8C	UP-TIME [7:0]							
AUTOSLPTI (High)	0x8D	UP-TIME [15:8]							
IRQST	0x91	PORIRQ	KBD1RQ			TIM2IRQ	TIM1IRQ	TIM0IRQ	GPIIRQ
IOCFG	0xA7	IOCFGPM [7:0]							
IOPC0 (Low)	0xAA	KPX3PR[1:0]		KPX2PR[1:0]		KPX1PR[1:0]		KPX0PR[1:0]	
IOPC0 (High)	0xAB	KPX7PR[1:0]		KPX6PR[1:0]		KPX5PR[1:0]		KPX4PR[1:0]	
IOPC1 (Low)	0xAC	KPY3PR[1:0]		KPY2PR[1:0]		KPY1PR[1:0]		KPY0PR[1:0]	
IOPC1 (High)	0xAD	KPY7PR[1:0]		KPY6PR[1:0]		KPY5PR[1:0]		KPY4PR[1:0]	
IOPC2 (Low)	0xAE	KPY11PR[1:0]		KPY10PR[1:0]		KPY9PR[1:0]		KPY8PR[1:0]	
IOPC2 (High)	0xAF	reserved							

REGISTER LAYOUT - Control Bits in LM8330 Registers (continued)

Register	Addr.	BIT 7	BIT 6	BIT 5	BIT 4	BIT 3	BIT 2	BIT 1	BIT 0
GPIODATA0	0xC0	DATA7	DATA6	DATA5	DATA4	DATA3	DATA2	DATA1	DATA0
GPIOMASK0	0xC1	MASK7	MASK6	MASK5	MASK4	MASK3	MASK2	MASK1	MASK0
GPIODATA1	0xC2	DATA15	DATA14	DATA13	DATA12	DATA11	DATA10	DATA9	DATA8
GPIOMASK1	0xC3	MASK15	MASK14	MASK13	MASK12	MASK11	DATA10	DATA9	DATA8
GPIODATA2	0xC4					DATA19	DATA18	DATA17	DATA16
GPIOMASK2	0xC5					MASK19	MASK18	MASK17	MASK16
GPIODIR0	0xC6	KPX7DIR	KPX6DIR	KPX5DIR	KPX4DIR	KPX3DIR	KPX2DIR	KPX1DIR	KPX0DIR
GPIODIR1	0xC7	KPY7DIR	KPY6DIR	KPY5DIR	KPY4DIR	KPY3DIR	KPY2DIR	KPY1DIR	KPY0DIR
GPIODIR2	0xC8					KP11DIR	KPY10DIR	KPY9DIR	KPY8DIR
GPIOIS0	0xC9	KPX7IS	KPX6IS	KPX5IS	KPX4IS	KPX3IS	KPX2IS	KPX1IS	KPX0IS
GPIOIS1	0xCA	KPY7IS	KPY6IS	KPY5IS	KPY4IS	KPY3IS	KPY2IS	KPY1IS	KPY0IS
GPIOIS2	0xCB					KPY11IS	KPY10IS	KPY9IS	KPY8IS
GPIOIBE0	0xCC	KPX7IBE	KPX6IBE	KPX5IBE	KPX4IBE	KPX3IBE	KPX2IBE	KPX1IBE	KPX0IBE
GPIOIBE1	0xCD	KPY7IBE	KPY6IBE	KPY5IBE	KPY4IBE	KPY3IBE	KPY2IBE	KPY1IBE	KPY0IBE
GPIOIBE2	0xCE					KPY11IBE	KPY10IBE	KPY9IBE	KPY8IBE
GPIOIEV0	0xCF	KPX7EV	KPX6EV	KPX5EV	KPX4EV	KPX3EV	KPX2EV	KPX1EV	KPX0EV
GPIOIEV1	0xD0	KPY7EV	KPY6EV	KPY5EV	KPY4EV	KPY3EV	KPY2EV	KPY1EV	KPY0EV
GPIOIEV2	0xD1					KPY11IEV	KPY10IEV	KPY9IEV	KPY8IEV
GPIOIE0	0xD2	KPX7IE	KPX6IE	KPX5IE	KPX4IE	KPX3IE	KPX2IE	KPX1IE	KPX0IE
GPIOIE1	0xD3	KPY7IE	KPY6IE	KPY5IE	KPY4IE	KPY3IE	KPY2IE	KPY1IE	KPY0IE
GPIOIE2	0xD4					KPY11IE	KPY10IE	KPY9IE	KPY8IE
GPIORIS0	0xD6	KPX7RIS	KPX6RIS	KPX5RIS	KPX4RIS	KPX3RIS	KPX2RIS	KPX1RIS	KPX0RIS
GPIORIS1	0xD7	KPY7RIS	KPY6RIS	KPY5RIS	KPY4RIS	KPY3RIS	KPY2RIS	KPY1RIS	KPY0RIS
GPIORIS2	0xD8					KPY11RIS	KPY10RIS	KPY9RIS	KPY8RIS
GPIOMIS0	0xD9	KPX7MIS	KPX6MIS	KPX5MIS	KPX4MIS	KPX3MIS	KPX2MIS	KPX1MIS	KPX0MIS
GPIOMIS1	0xDA	KPY7MIS	KPY6MIS	KPY5MIS	KPY4MIS	KPY3MIS	KPY2MIS	KPY1MIS	KPY0MIS
GPIOMIS2	0xDB					KPY11MIS	KPY10MIS	KPY9MIS	KPY8MIS
GPIOIC0	0xDC	KPX7IC	KPX6IC	KPX5IC	KPX4IC	KPX3IC	KPX2IC	KPX1IC	KPX0IC
GPIOIC1	0xDD	KPY7IC	KPY6IC	KPY5IC	KPY4IC	KPY3IC	KPY2IC	KPY1IC	KPY0IC
GPIOIC2	0xDE					KPY11IC	KPY10IC	KPY9IC	KPY8IC
GPIOOME0	0xE0	KPX7ODE	KPX6ODE	KPX5ODE	KPX4ODE	KPX3ODE	KPX2ODE	KPX1ODE	KPX0ODE
GPIOOMS0	0xE1	KPX7ODM	KPX6ODM	KPX5ODM	KPX4ODM	KPX3ODM	KPX2ODM	KPX1ODM	KPX0ODM
GPIOOME1	0xE2	KPY7ODE	KPY6ODE	KPY5ODE	KPY4ODE	KPY3ODE	KPY2ODE	KPY1ODE	KPY0ODE
GPIOOMS1	0xE3	KPY7ODM	KPY6ODM	KPY5ODM	KPY4ODM	KPY3ODM	KPY2ODM	KPY1ODM	KPY0ODM
GPIOOME2	0xE4					KPY11ODE	KPY10ODE	KPY9ODE	KPY8ODE
GPIOOMS2	0xE5					KPY11ODM	KPY10ODM	KPY9ODM	KPY8ODM
GPIOWAKE0	0xE9	KPX7 WAKE	KPX6 WAKE	KPX5 WAKE	KPX4 WAKE	KPX3 WAKE	KPX2 WAKE	KPX1 WAKE	KPX0 WAKE
GPIOWAKE1	0xEA	KPY7 WAKE	KPY6 WAKE	KPY5 WAKE	KPY4 WAKE	KPY3 WAKE	KPY2 WAKE	KPY1 WAKE	KPY0 WAKE
GPIOWAKE2	0xEB					KPY11 WAKE	KPY10 WAKE	KPY9 WAKE	KPY8 WAKE

REVISION HISTORY

Changes from Original (March 2013) to Revision A	Page
<hr/> <ul style="list-style-type: none">• Changed layout of National Data Sheet to TI format	<hr/> 45

PACKAGING INFORMATION

Orderable Device	Status (1)	Package Type	Package Drawing	Pins	Package Qty	Eco Plan (2)	Lead finish/ Ball material (6)	MSL Peak Temp (3)	Op Temp (°C)	Device Marking (4/5)	Samples
LM8330TME/NOPB	ACTIVE	DSBGA	YFQ	25	250	RoHS & Green	SNAGCU	Level-1-260C-UNLIM	-30 to 85	8330	Samples
LM8330TMX/NOPB	ACTIVE	DSBGA	YFQ	25	3000	RoHS & Green	SNAGCU	Level-1-260C-UNLIM	-30 to 85	8330	Samples

(1) The marketing status values are defined as follows:

ACTIVE: Product device recommended for new designs.

LIFEBUY: TI has announced that the device will be discontinued, and a lifetime-buy period is in effect.

NRND: Not recommended for new designs. Device is in production to support existing customers, but TI does not recommend using this part in a new design.

PREVIEW: Device has been announced but is not in production. Samples may or may not be available.

OBsolete: TI has discontinued the production of the device.

(2) **RoHS:** TI defines "RoHS" to mean semiconductor products that are compliant with the current EU RoHS requirements for all 10 RoHS substances, including the requirement that RoHS substance do not exceed 0.1% by weight in homogeneous materials. Where designed to be soldered at high temperatures, "RoHS" products are suitable for use in specified lead-free processes. TI may reference these types of products as "Pb-Free".

RoHS Exempt: TI defines "RoHS Exempt" to mean products that contain lead but are compliant with EU RoHS pursuant to a specific EU RoHS exemption.

Green: TI defines "Green" to mean the content of Chlorine (Cl) and Bromine (Br) based flame retardants meet JS709B low halogen requirements of <=1000ppm threshold. Antimony trioxide based flame retardants must also meet the <=1000ppm threshold requirement.

(3) MSL, Peak Temp. - The Moisture Sensitivity Level rating according to the JEDEC industry standard classifications, and peak solder temperature.

(4) There may be additional marking, which relates to the logo, the lot trace code information, or the environmental category on the device.

(5) Multiple Device Markings will be inside parentheses. Only one Device Marking contained in parentheses and separated by a "~" will appear on a device. If a line is indented then it is a continuation of the previous line and the two combined represent the entire Device Marking for that device.

(6) Lead finish/Ball material - Orderable Devices may have multiple material finish options. Finish options are separated by a vertical ruled line. Lead finish/Ball material values may wrap to two lines if the finish value exceeds the maximum column width.

Important Information and Disclaimer:The information provided on this page represents TI's knowledge and belief as of the date that it is provided. TI bases its knowledge and belief on information provided by third parties, and makes no representation or warranty as to the accuracy of such information. Efforts are underway to better integrate information from third parties. TI has taken and continues to take reasonable steps to provide representative and accurate information but may not have conducted destructive testing or chemical analysis on incoming materials and chemicals. TI and TI suppliers consider certain information to be proprietary, and thus CAS numbers and other limited information may not be available for release.

In no event shall TI's liability arising out of such information exceed the total purchase price of the TI part(s) at issue in this document sold by TI to Customer on an annual basis.

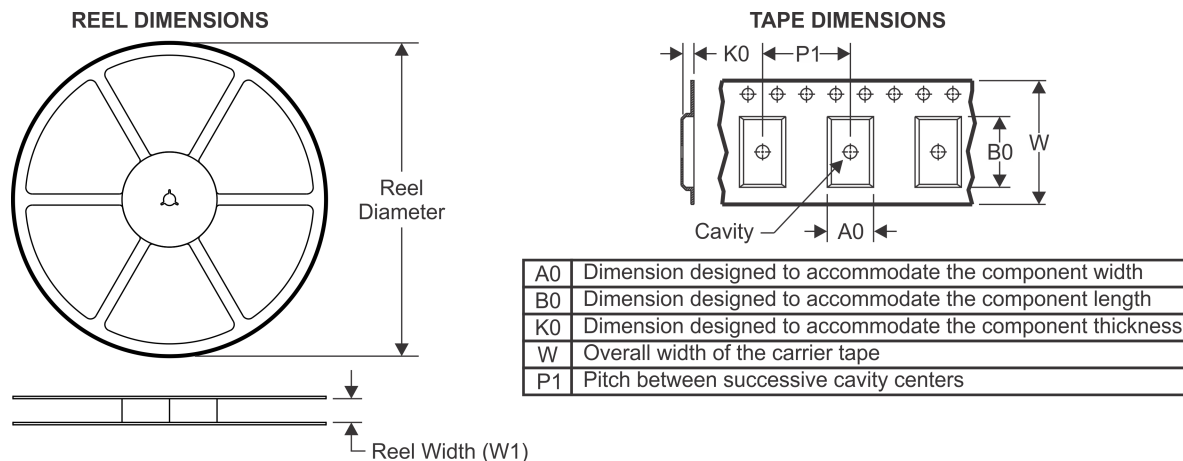
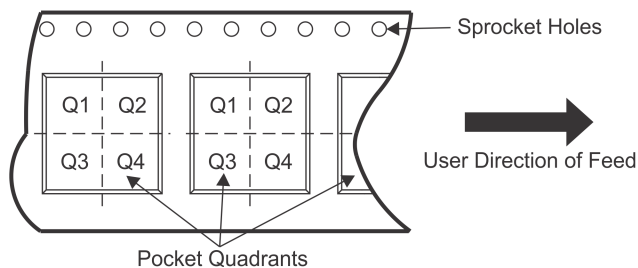
TAPE AND REEL INFORMATION

QUADRANT ASSIGNMENTS FOR PIN 1 ORIENTATION IN TAPE

*All dimensions are nominal

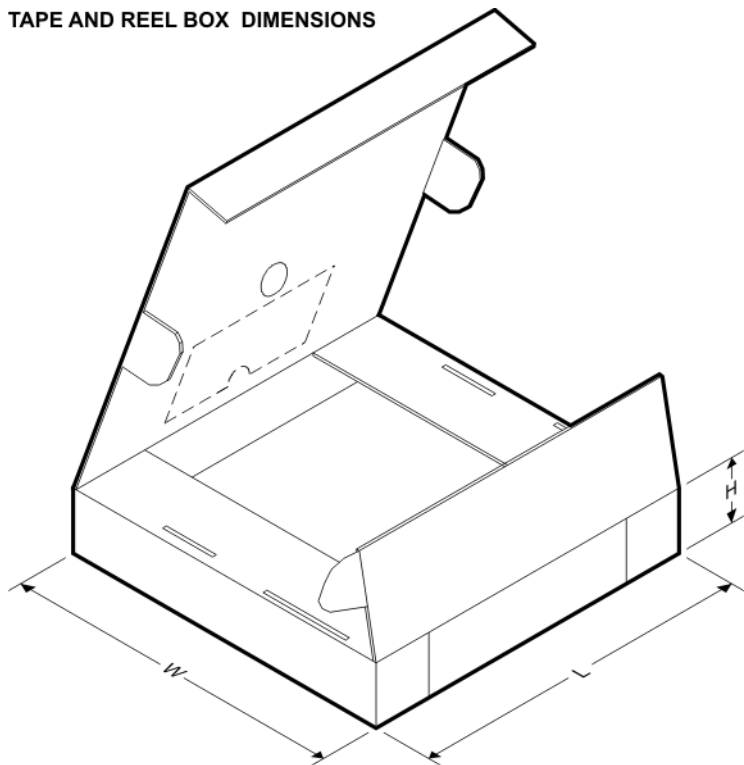
Device	Package Type	Package Drawing	Pins	SPQ	Reel Diameter (mm)	Reel Width W1 (mm)	A0 (mm)	B0 (mm)	K0 (mm)	P1 (mm)	W (mm)	Pin1 Quadrant
LM8330TME/NOPB	DSBGA	YFQ	25	250	178.0	8.4	2.08	2.08	0.76	4.0	8.0	Q1
LM8330TMX/NOPB	DSBGA	YFQ	25	3000	178.0	8.4	2.08	2.08	0.76	4.0	8.0	Q1

TAPE AND REEL BOX DIMENSIONS

*All dimensions are nominal

Device	Package Type	Package Drawing	Pins	SPQ	Length (mm)	Width (mm)	Height (mm)
LM8330TME/NOPB	DSBGA	YFQ	25	250	208.0	191.0	35.0
LM8330TMX/NOPB	DSBGA	YFQ	25	3000	208.0	191.0	35.0

YFQ0025

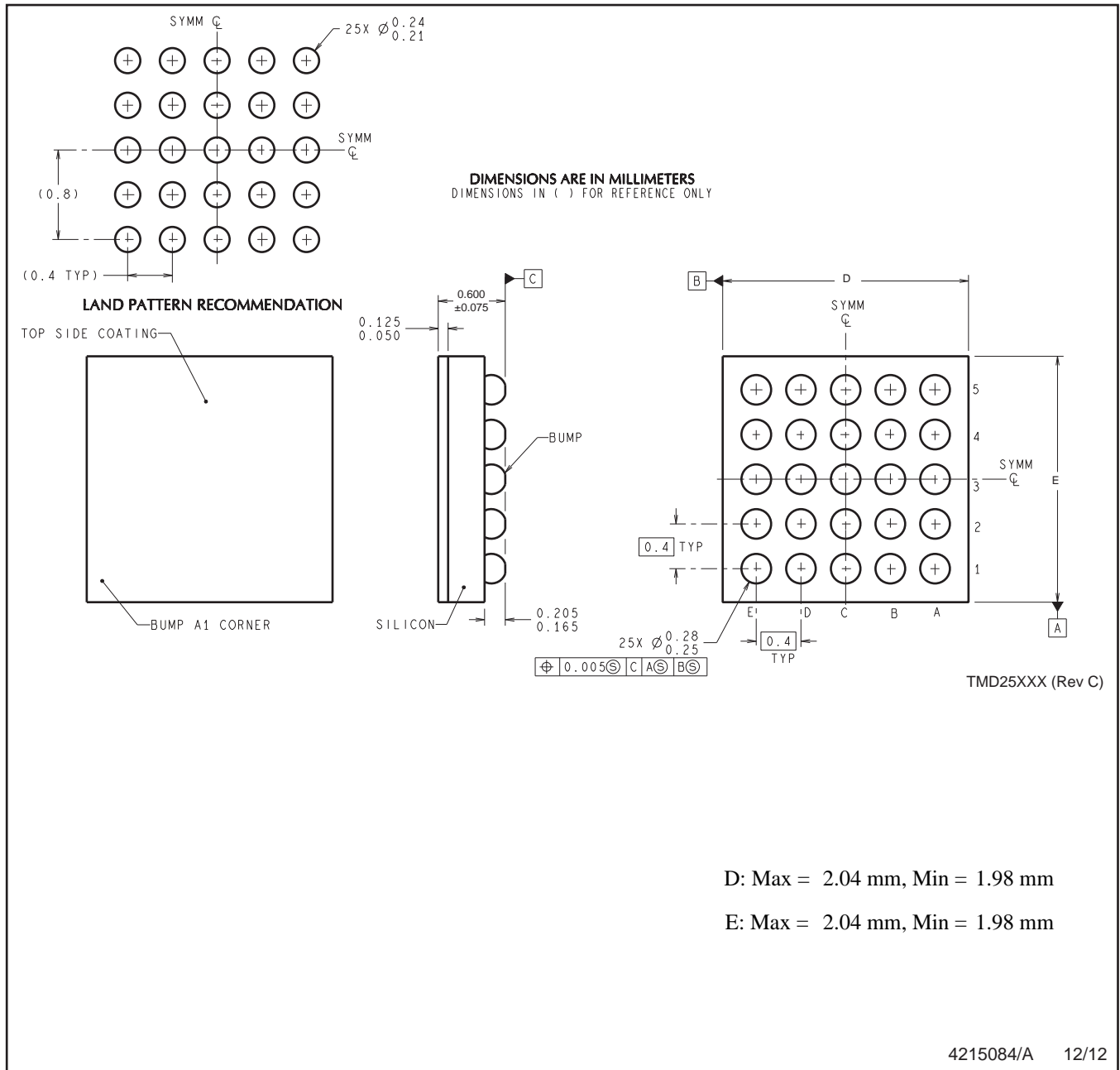

NOTES: A. All linear dimensions are in millimeters. Dimensioning and tolerancing per ASME Y14.5M-1994.
B. This drawing is subject to change without notice.

4215084/A 12/12

IMPORTANT NOTICE AND DISCLAIMER

TI PROVIDES TECHNICAL AND RELIABILITY DATA (INCLUDING DATA SHEETS), DESIGN RESOURCES (INCLUDING REFERENCE DESIGNS), APPLICATION OR OTHER DESIGN ADVICE, WEB TOOLS, SAFETY INFORMATION, AND OTHER RESOURCES "AS IS" AND WITH ALL FAULTS, AND DISCLAIMS ALL WARRANTIES, EXPRESS AND IMPLIED, INCLUDING WITHOUT LIMITATION ANY IMPLIED WARRANTIES OF MERCHANTABILITY, FITNESS FOR A PARTICULAR PURPOSE OR NON-INFRINGEMENT OF THIRD PARTY INTELLECTUAL PROPERTY RIGHTS.

These resources are intended for skilled developers designing with TI products. You are solely responsible for (1) selecting the appropriate TI products for your application, (2) designing, validating and testing your application, and (3) ensuring your application meets applicable standards, and any other safety, security, regulatory or other requirements.

These resources are subject to change without notice. TI grants you permission to use these resources only for development of an application that uses the TI products described in the resource. Other reproduction and display of these resources is prohibited. No license is granted to any other TI intellectual property right or to any third party intellectual property right. TI disclaims responsibility for, and you will fully indemnify TI and its representatives against, any claims, damages, costs, losses, and liabilities arising out of your use of these resources.

TI's products are provided subject to [TI's Terms of Sale](#) or other applicable terms available either on ti.com or provided in conjunction with such TI products. TI's provision of these resources does not expand or otherwise alter TI's applicable warranties or warranty disclaimers for TI products.

TI objects to and rejects any additional or different terms you may have proposed.

Mailing Address: Texas Instruments, Post Office Box 655303, Dallas, Texas 75265
Copyright © 2021, Texas Instruments Incorporated