



## Table of Contents

<b>1 特性</b> .....	1	9.1 Application Information.....	14
<b>2 应用</b> .....	1	9.2 Typical 12-V Reverse Battery Protection Application.....	14
<b>3 说明</b> .....	1	9.3 Do's and Don'ts.....	22
<b>4 Revision History</b> .....	2	<b>10 Power Supply Recommendations</b> .....	23
<b>5 Pin Configuration and Functions</b> .....	3	10.1 Transient Protection.....	23
<b>6 Specifications</b> .....	4	10.2 TVS Selection for 12-V Battery Systems.....	24
6.1 Absolute Maximum Ratings.....	4	10.3 TVS Selection for 24-V Battery Systems.....	24
6.2 ESD Ratings.....	4	<b>11 Layout</b> .....	25
6.3 Recommended Operating Conditions.....	4	11.1 Layout Guidelines.....	25
6.4 Thermal Information.....	5	11.2 Layout Example.....	25
6.5 Electrical Characteristics.....	5	<b>12 Device and Documentation Support</b> .....	26
6.6 Switching Characteristics.....	6	12.1 第三方产品免责声明.....	26
6.7 Typical Characteristics.....	7	12.2 接收文档更新通知.....	26
<b>7 Parameter Measurement Information</b> .....	9	12.3 支持资源.....	26
<b>8 Detailed Description</b> .....	10	12.4 Trademarks.....	26
8.1 Overview.....	10	12.5 Electrostatic Discharge Caution.....	26
8.2 Functional Block Diagram.....	10	12.6 术语表.....	26
8.3 Feature Description.....	11	<b>13 Mechanical, Packaging, and Orderable Information</b> .....	26
8.4 Device Functional Mode (Shutdown Mode).....	13		
<b>9 Application and Implementation</b> .....	14		

## 4 Revision History

注：以前版本的页码可能与当前版本的页码不同

<b>Changes from Revision A (January 2022) to Revision B (March 2022)</b>	<b>Page</b>
• 将状态从“预告信息”更改为“量产数据” .....	1

<b>Changes from Revision * (September 2021) to Revision A (January 2022)</b>	<b>Page</b>
• Updated the <i>Electrical Characteristics</i> and <i>Switching Characteristics</i> with specification limits.....	4
• Added the <i>Typical Characteristics</i> section.....	7

## 5 Pin Configuration and Functions



图 5-1. WSON 12-Pin DRR Transparent Top View

表 5-1. Pin Functions

NAME	PIN		TYPE	DESCRIPTION
	LM74720-Q1	DRR-12 (WSON)		
GATE	1	1	O	Diode controller gate drive output. Connect to the GATE of the external MOSFET.
A	2	2	I	Anode of the ideal diode. Connect to the source of the external MOSFET.
VSNS	3	3	I	Voltage sensing input
SW	4	4	I	Voltage sensing disconnect switch terminal. VSNS and SW are internally connected through a switch. Use SW as the top connection of the battery sensing or OV resistor ladder network. When EN is pulled low, the switch is OFF, disconnecting the resistor ladder from the battery line, thereby cutting off the leakage current. If the internal disconnect switch between VSNS and SW is not used, then short them together and connect to C pin.
OV	5	5	I	Adjustable overvoltage threshold input. Connect a resistor ladder across SW to OV terminal. When the voltage at OV exceeds the overvoltage cut-off threshold, then the PD is pulled low turning OFF the HSFET. PD is driven high when the sense voltage goes below the OV falling threshold.
EN	6	6	I	EN Input. Connect to A or C pin for always ON operation. In this mode, the device consumes an IQ of 35 $\mu$ A (maximum). Can be driven externally from a micro controller I/O. Pulling the pin low below 0.5 V enters the device in low IQ shutdown mode.
GND	7	7	G	Connect to the system ground plane.
PD	8	8	O	Pull down connection for the external load disconnect FET. Connect to the GATE of the external FET to PD pin. Leave PD pin floating if the load disconnect FET is not used.
LX	9	9	I	Switch node of the internal boost regulator. This node must be kept small on the PCB for good performance and low EMI. Connect the boost inductor between this pin and the DRAIN connection of the external FET.
CAP	10	10	O	Boost Regulator Output. This pin is used to provide a drive voltage to the gate driver of the ideal diode stage as well as drive supply for the HSFET. Connect a 1- $\mu$ F capacitor between this pin and the VS pin.
VS	11	11	I	Supply voltage pin
C	12	12	I	Cathode of the ideal diode. Connect to the DRAIN of the external MOSFET. The voltage sensed at this pin is used to control the external MOSFET GATE.
RTN	Thermal Pad		—	Leave exposed pad floating. Do not connect to GND plane.

## 6 Specifications

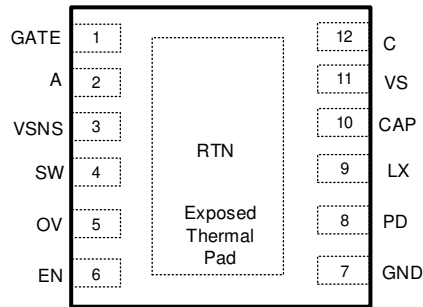
### 6.1 Absolute Maximum Ratings

over operating free-air temperature range (unless otherwise noted)<sup>(1)</sup>

		MIN	MAX	UNIT
Input Pins	A to GND	- 65	70	V
	VS, C to GND	- 0.3	70	
	VSNS, SW, EN, OV to GND, $V_{(A)} > 0$ V	- 0.3	70	
	VSNS, SW, EN, OV to GND, $V_{(A)} \leq 0$ V	$V_{(A)}$	$(70 + V_{(A)})$	
	RTN to GND	- 65	0.3	mA
	$I_{VSNS}, I_{SW}$	- 1	10	
	$I_{EN}, I_{OV}, V_{(A)} > 0$ V	- 1		
	$I_{EN}, I_{OV}, V_{(A)} \leq 0$ V	Internally limited		
Output Pins	CAP to C	- 0.3	15.9	V
	CAP to A	- 0.3	85	
	GATE to A	- 0.3	15	
	LX, CAP, PD to GND	- 0.3	85	
Output to Input Pins	C to A	- 5	85	
Operating junction temperature, $T_J$ <sup>(2)</sup>		- 40	150	°C
Storage temperature, $T_{stg}$		- 40	150	

- Operation outside the Absolute Maximum Ratings may cause permanent device damage. Absolute Maximum Ratings do not imply functional operation of the device at these or any other conditions beyond those listed under Recommended Operating Conditions. If used outside the Recommended Operating Conditions but within the Absolute Maximum Ratings, the device may not be fully functional, and this may affect device reliability, functionality, performance, and shorten the device lifetime
- High junction temperatures degrade operating lifetimes. Operating lifetime is de-rated for junction temperatures greater than 125°C.

### 6.2 ESD Ratings

			VALUE	UNIT	
$V_{(ESD)}$	Electrostatic discharge	Human body model (HBM), per AEC Q100-002 <sup>(1)</sup>	±2000	V	
		Charged device model (CDM), per AEC Q100-011	Corner pins (GATE, EN, GND, C)		±750
			Other pins		±500

- AEC-Q100-002 indicates that HBM stressing shall be in accordance with the ANSI/ESDA/JEDEC JS-001 specifications.

### 6.3 Recommended Operating Conditions

over operating free-air temperature range (unless otherwise noted)<sup>(1)</sup>

		MIN	NOM	MAX	UNIT
Input Pins	A to GND	- 60		65	V
	C to GND			65	
	EN to GND	- 60		65	
External capacitance	A	0.1			µF
	VS, CAP to C	1			µF
External Inductor	LX	100			µH
External MOSFET max $V_{GS}$ rating	GATE to A	15			V
$T_J$	Operating junction temperature range <sup>(2)</sup>	- 40		150	°C

- Recommended Operating Conditions are conditions under which the device is intended to be functional. For specifications and test

conditions, see [Electrical Characteristics](#).

- (2) High junction temperatures degrade operating lifetimes. Operating lifetime is de-rated for junction temperatures greater than 125°C.

## 6.4 Thermal Information

THERMAL METRIC <sup>(1)</sup>		LM74720-Q1	UNIT
		DRR (WSON)	
		12 PINS	
$R_{\theta JA}$	Junction-to-ambient thermal resistance	61.6	°C/W
$R_{\theta JC(top)}$	Junction-to-case (top) thermal resistance	50	°C/W
$R_{\theta JB}$	Junction-to-board thermal resistance	32.7	°C/W
$\Psi_{JT}$	Junction-to-top characterization parameter	1.4	°C/W
$\Psi_{JB}$	Junction-to-board characterization parameter	32.7	°C/W
$R_{\theta JC}$	Junction-to-case (bottom) thermal resistance	6.9	°C/W

- (1) For more information about traditional and new thermal metrics, see the Semiconductor and IC Package Thermal Metrics application report, SPRA953.

## 6.5 Electrical Characteristics

$T_J = -40^\circ\text{C}$  to  $+125^\circ\text{C}$ ; typical values at  $T_J = 25^\circ\text{C}$ ,  $V_{(A)} = V_{(VS)} = 12\text{ V}$ ,  $C_{(CAP)} = 1\ \mu\text{F}$ ,  $V_{(EN)} = 2\text{ V}$ , over operating free-air temperature range (unless otherwise noted)

PARAMETER		TEST CONDITIONS	MIN	TYP	MAX	UNIT
<b>SUPPLY VOLTAGE</b>						
$V_{(A\ POR)}$	VA POR Rising threshold		3.1	3.4	3.85	V
	VA POR Falling threshold		2.2	2.6	2.9	V
$V_{(VS)}$	Minimum Voltage at VS				3	V
$I_{(SHDN)}$	Shutdown Supply Current	$V_{(EN)} = 0\text{ V}$		1.5	3.3	$\mu\text{A}$
$I_{(Q)}$	Total System Quiescent Current	$V_{(EN)} = 2\text{ V}$ , Active Rectifier Controller In Regulation, $-40^\circ\text{C} \leq T_J \leq +85^\circ\text{C}$		27	32	$\mu\text{A}$
		$V_{(EN)} = 2\text{ V}$ , Active Rectifier Controller In Regulation, $-40^\circ\text{C} \leq T_J \leq +125^\circ\text{C}$		27	35	$\mu\text{A}$
<b>ENABLE INPUT</b>						
$V_{(EN\_IH)}$	Enable input high threshold				2	V
$V_{(EN\_IL)}$	Enable input low threshold		0.5	0.85	1.2	
$V_{(EN\_Hys)}$	Enable Hysteresis			380		mV
$I_{(EN)}$	Enable sink current	$V_{(EN)} = 12\text{ V}$		52	155	nA
<b><math>V_{ANODE}</math> to <math>V_{CATHODE}</math> (<math>V_A - C</math>)</b>						
$V_{(AC\ REG)}$	Regulated Forward $V_{(AC)}$ Threshold		9	16.4	22.7	mV
$V_{(AC\_FWD)}$	$V_{(AC)}$ threshold from RCB to oFCB		75	105	140	mV
$V_{(AC\_REV)}$	$V_{(AC)}$ threshold for reverse current blocking		-12	-5.65	-1.3	mV
<b>GATE DRIVE</b>						
$V_{(GATE)} - V_{(A)}$		$3\text{ V} < V_{(VS)} < 65\text{ V}$	9.5		13	V
$I_{(GATE)}$	Peak sink current	$V_{(A)} - V_{(C)} = -20\text{ mV}$		2.5		A
	Regulation max sink current	$V_{(A)} - V_{(C)} = 0\text{ V}$ , $V_{(GATE)} - V_{(A)} = 5\text{ V}$	14	26	39	$\mu\text{A}$
$R_{GATE}$	GATE pulldown resistance	$V_{(A)} - V_{(C)} = -20\text{ mV}$ , $V_{(GATE)} - V_{(A)} = 100\text{ mV}$		1.2		$\Omega$
<b>BOOST REGULATOR</b>						
$V_{(CAP)} - V_{(VS)}$	Boost output rising threshold			13	15.5	V
	Hysteresis			1.1		V

## 6.5 Electrical Characteristics (continued)

$T_J = -40^{\circ}\text{C}$  to  $+125^{\circ}\text{C}$ ; typical values at  $T_J = 25^{\circ}\text{C}$ ,  $V_{(A)} = V_{(VS)} = 12\text{ V}$ ,  $C_{(CAP)} = 1\ \mu\text{F}$ ,  $V_{(EN)} = 2\text{ V}$ , over operating free-air temperature range (unless otherwise noted)

PARAMETER		TEST CONDITIONS	MIN	TYP	MAX	UNIT
$I_{(CAP)}$	Boost load capacity	$V_{(CAP)} - V_{(VS)} = 7.5\text{ V}$		29		mA
$I_{(LX)}$	Peak inductor current limit threshold	$V_{(VS)} = 12\text{ V}$	110	140	170	mA
		$V_{(VS)} = 3\text{ V}$			210	mA
$R_{(LX)}$	Low side switch On-Resistance		1.3	2.7	5.1	$\Omega$
<b>BATTERY SENSING (VSNS, SW) AND OVER VOLTAGE DETECTION (OV, PD)</b>						
$R_{(SW)}$	Battery sensing disconnect switch resistance		104	226	430	$\Omega$
$V_{(OVR)}$	Overvoltage threshold input, rising		1.13	1.231	1.33	V
$V_{(OVF)}$	Overvoltage threshold input, falling		1.03	1.125	1.215	V
$V_{(OV\_Hys)}$	OV Hysteresis			110		mV
$I_{(OV)}$	OV Input leakage current	$0\text{ V} < V_{(OV)} < 5\text{ V}$		50	110	nA
$I_{(PD\_SRC)}$	Pullup current	$3\text{ V} < V_{(VS)} < 65\text{ V}$	43	50	60	$\mu\text{A}$
$I_{(PD\_SINK)}$	Peak pulldown current	$V_{(OV)} > V_{(OVR)}$	55	88	117	mA
	DC pulldown current		7	10	14	mA
<b>CATHODE (C)</b>						
$I_{(C)}$	CATHODE sink current	$V_{(A)} = 12\text{ V}$ , $V_{(A)} - V_{(C)} = -100\text{ mV}$		8.5	15	$\mu\text{A}$
		$V_{(A)} = -14\text{ V}$ , $V_{(C)} = 14\text{ V}$		10.6	18	$\mu\text{A}$

## 6.6 Switching Characteristics

$T_J = -40^{\circ}\text{C}$  to  $+125^{\circ}\text{C}$ ; typical values at  $T_J = 25^{\circ}\text{C}$ ,  $V_{(A)} = V_{(VS)} = 12\text{ V}$ ,  $C_{(CAP)} = 1\ \mu\text{F}$ ,  $V_{(EN)} = 2\text{ V}$ , over operating free-air temperature range (unless otherwise noted)

PARAMETER		TEST CONDITIONS	MIN	TYP	MAX	UNIT
$EN_{TDLY}$	A (low to high) to GATE Turn On delay	$V_{(A)} \uparrow V_{(A\text{ POR})}$ to $V_{(GATE - A)} > 5\text{ V}$ , $C_{(GATE - A)} = 10\text{ nF}$ ,			200	$\mu\text{s}$
$t_{GATE\_OFF(DLY)}$	Reverse voltage detection to Gate Turn Off delay	$V_{(A)} - V_{(C)} = +30\text{ mV}$ to $-100\text{ mV}$ , $V_{(GATE)} - V_{(A)} < 1\text{ V}$ , $C_{(GATE - A)} = 10\text{ nF}$		0.47	0.81	$\mu\text{s}$
$t_{GATE\_ON(DLY)}$	Forward voltage detection to Gate Turn On delay	$V_{(A)} - V_{(C)} = -100\text{ mV}$ to $+700\text{ mV}$ , $V_{(GATE)} - V_{(A)} > 5\text{ V}$ , $C_{(GATE - A)} = 10\text{ nF}$		1.9	2.9	$\mu\text{s}$
$t_{EN\_OFF(DLY)PD}$	EN to PD Delay	EN $\downarrow$ to PD $\downarrow$		6.5	12	$\mu\text{s}$
$t_{OV\_OFF(DLY)PD}$	OV to PD Delay	OV $\uparrow$ to PD $\downarrow$		0.9	1.5	$\mu\text{s}$
$t_{PD\_PK}$	Peak Pull Down duration	$I_{(PD\_SINK, PK)} \uparrow$ to $I_{(PD\_SINK, DC)} \downarrow$	11	38	65	$\mu\text{s}$

## 6.7 Typical Characteristics



图 6-1. Operating Quiescent Current vs Supply Voltage



图 6-2. Shutdown Supply Current vs Supply Voltage

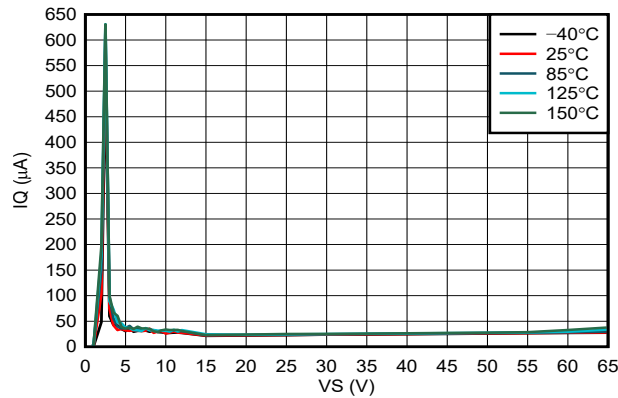

图 6-3. VA POR Threshold vs Temperature

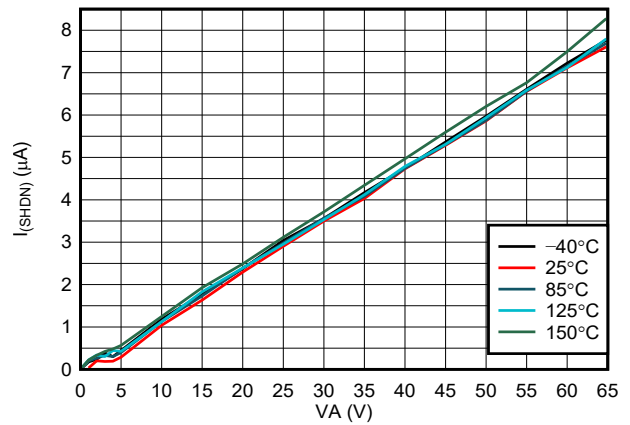

图 6-4. VS POR Threshold vs Temperature

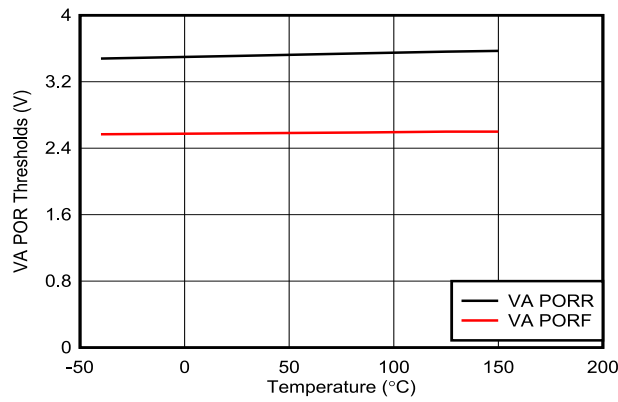

图 6-5. Boost Comparator Threshold vs Temperature

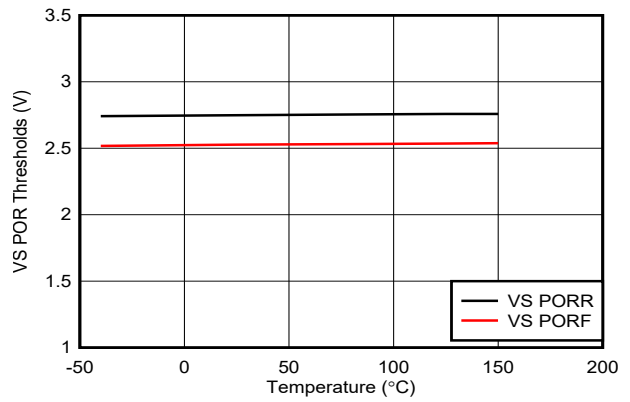

图 6-6. Boost Loading Capacity vs Temperature

### 6.7 Typical Characteristics (continued)

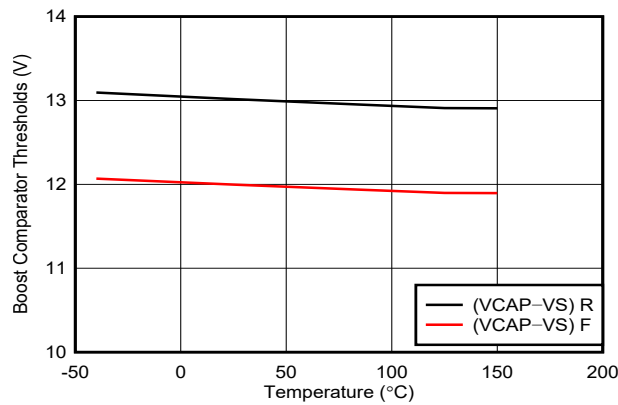

图 6-7. OV Threshold vs Temperature

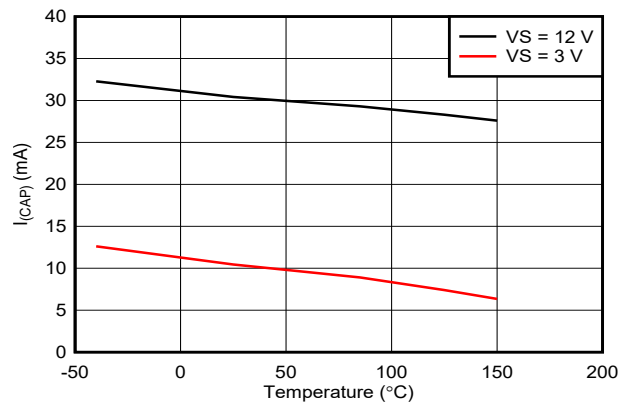

图 6-8. PD Turn-off Delay During OV

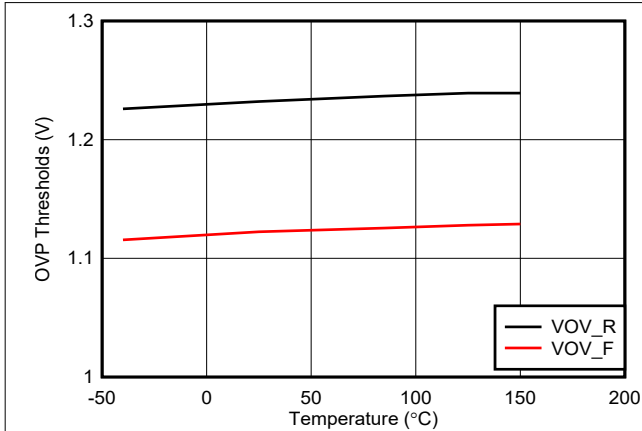

图 6-9. PD Turn-off Delay During EN

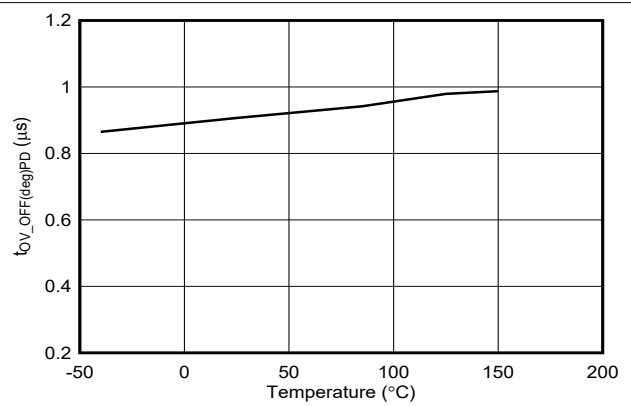

图 6-10. Forward Turn-on Delay vs Temperature

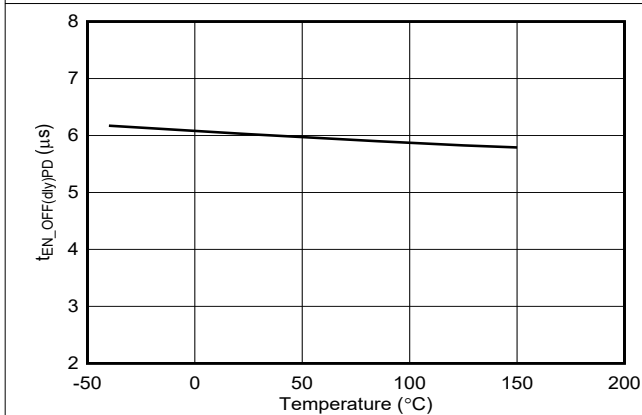

图 6-11. Gate Current vs Forward Voltage Drop

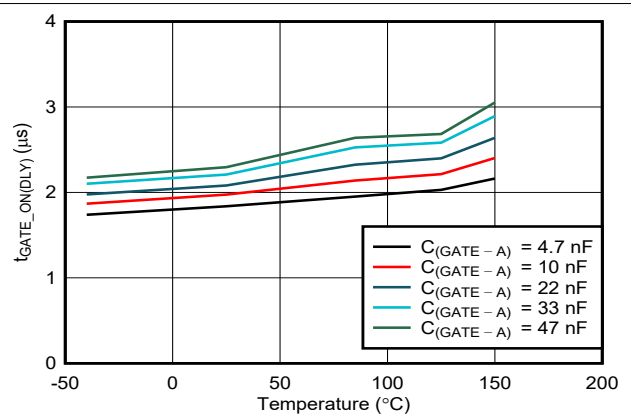

图 6-12. PD Turn-off Delay vs Supply Voltage

## 7 Parameter Measurement Information

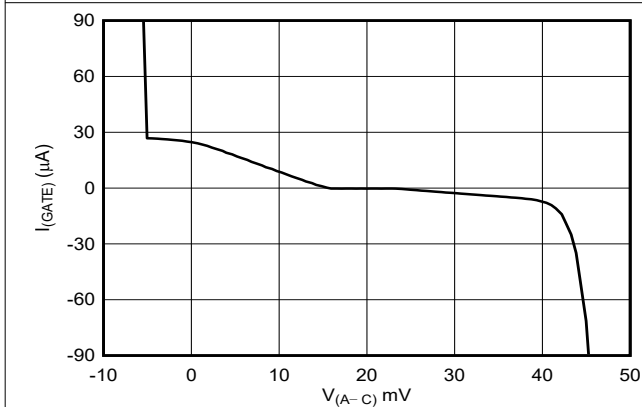

图 7-1. Timing Waveforms

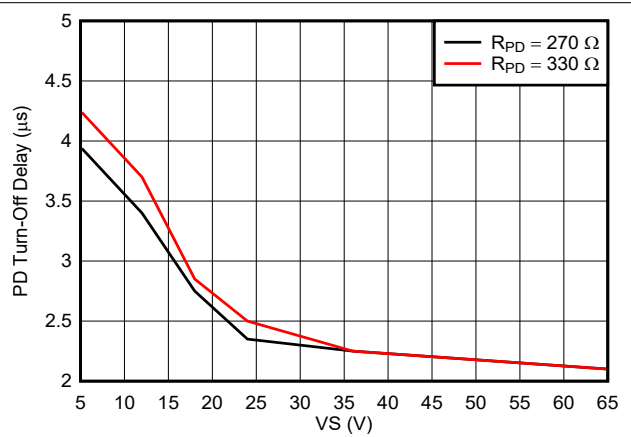
## 8 Detailed Description

### 8.1 Overview

The LM74720-Q1 ideal diode controller drives and controls external back-to-back N-Channel MOSFETs to emulate an ideal diode rectifier with power path ON and OFF control and overvoltage protection. The wide input supply of 3 V to 65 V allows protection and control of 12-V and 24-V automotive battery powered ECUs. IQ during operation (EN = High) is <math>< 35 \mu\text{A}</math> and <math>< 3.3 \mu\text{A}</math> during shutdown mode (EN = Low). The device can withstand and protect the loads from negative supply voltages down to  $-65 \text{ V}$ . An integrated ideal diode controller (GATE) drives the first MOSFET to replace a Schottky diode for reverse input protection and output voltage holdup. A strong 29-mA boost regulator and short turn-ON and turn-OFF delay times of comparators ensures fast transient response ensuring robust and efficient MOSFET switching performance during automotive testing such as ISO16750 or LV124 where an ECU is subjected to input short interruptions and AC superimpose input signals up to 100-kHz frequency. The device features an adjustable over voltage cut-off protection feature for load dump protection.

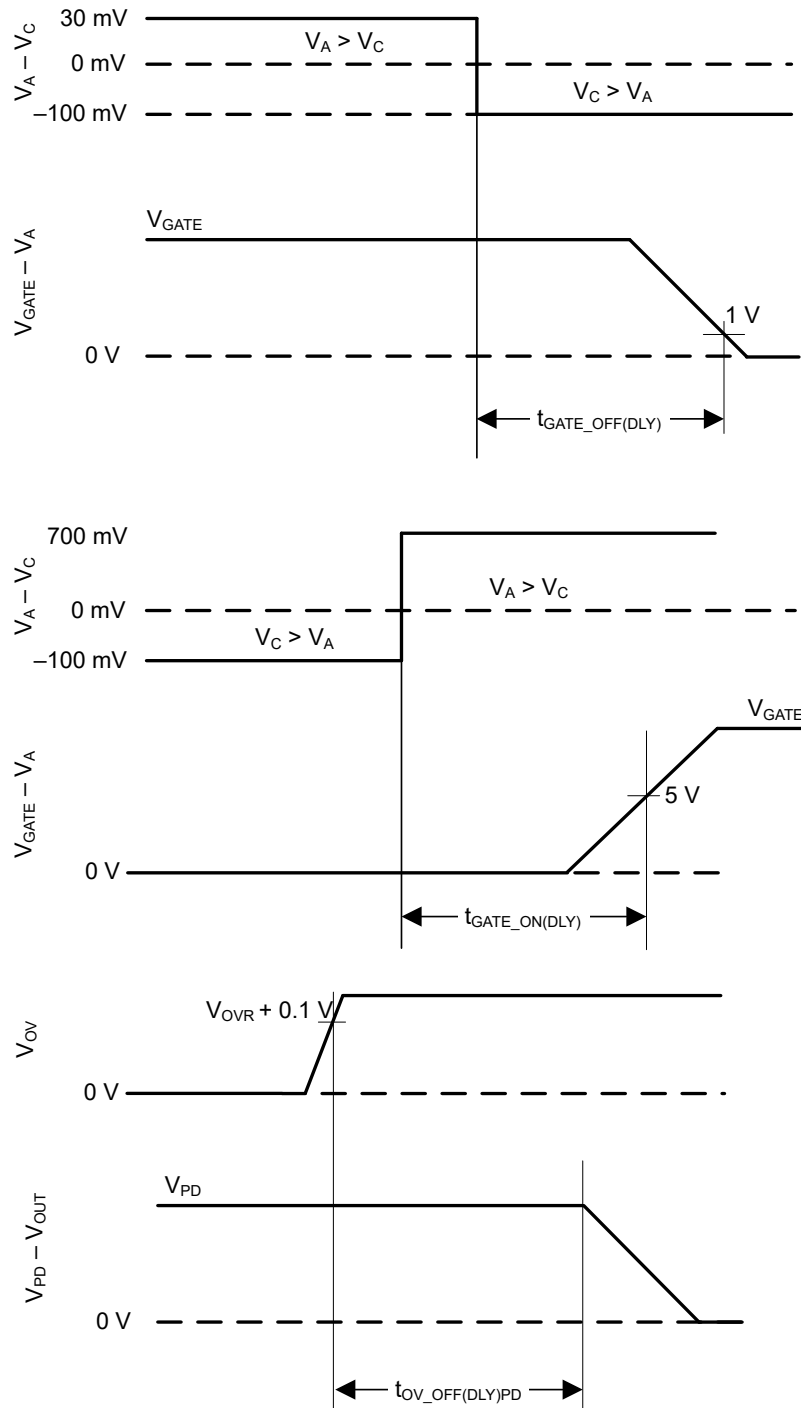
The LM74720-Q1 controls the GATE of the MOSFET to regulate the forward voltage drop at 17 mV. The linear regulation scheme in these devices enables graceful control of the GATE voltage and turns off of the MOSFET during a reverse current event and ensures zero DC reverse current flow.

Low quiescent current (<math>< 35 \mu\text{A}</math>) in operation enables always ON system designs. With a second MOSFET in the power path, the device allows load disconnect control using EN pin. Quiescent current reduces to  $3.3 \mu\text{A}$  with EN low.

### 8.2 Functional Block Diagram

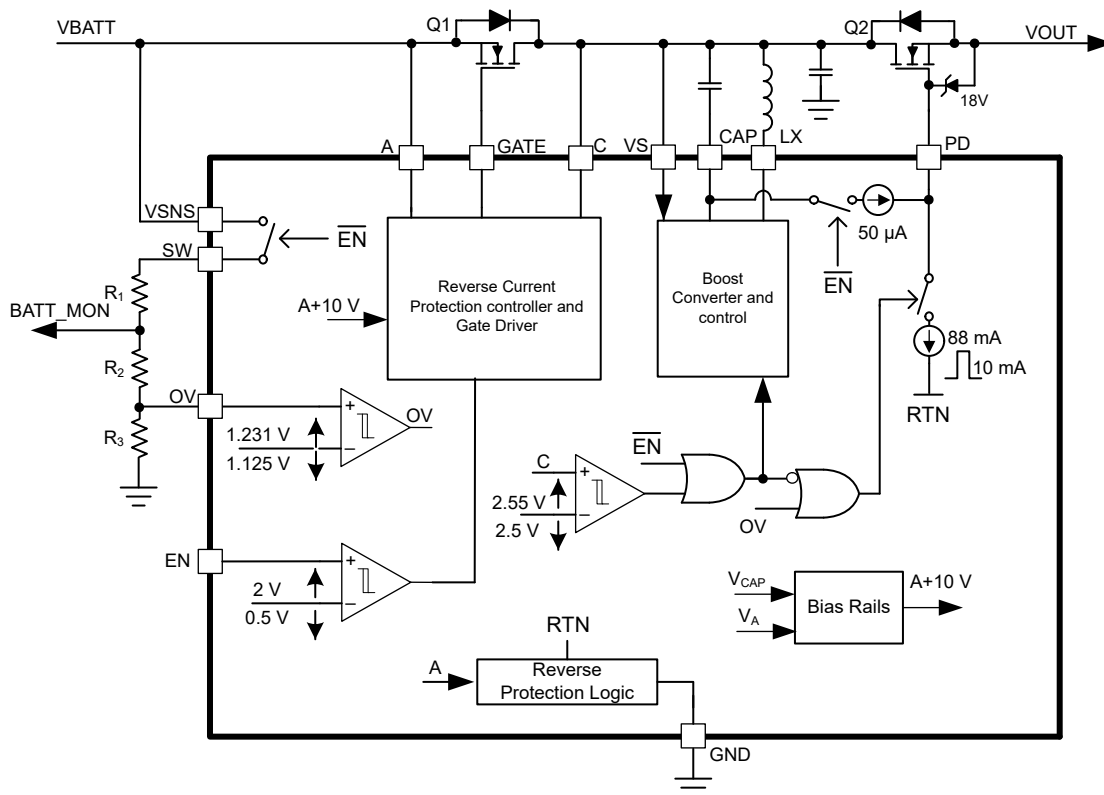

## 8.3 Feature Description

### 8.3.1 Dual Gate Control (GATE, PD)

The LM74720-Q1 features two separate gate control and driver outputs. That is, GATE and PD to drive back-to-back N-channel MOSFETs.

#### 8.3.1.1 Reverse Battery Protection (A, C, GATE)

A, C, GATE comprises of Ideal Diode stage. Connect the Source of the external MOSFET to A, Drain to C and Gate to GATE pin. The LM74720-Q1 has integrated reverse input protection down to  $-65\text{ V}$ .

In LM74720-Q1, the voltage drop across the MOSFET is continuously monitored between the A and C pins, and the GATE to A voltage is adjusted as needed to regulate the forward voltage drop at  $17\text{ mV}$  (typical) for LM74720-Q1. This closed loop regulation scheme enables graceful turn-off of the MOSFET during a reverse current event and ensures zero DC reverse current flow. This scheme ensures robust performance during slow input voltage ramp down tests. Along with the linear regulation amplifier scheme, the LM74720-Q1 also integrates a fast reverse voltage comparator. When the voltage drop across A and C reaches  $V_{(AC\_REV)}$  threshold, then the GATE goes low within  $0.5\text{ }\mu\text{s}$  (typical). This fast reverse voltage comparator scheme ensures robust performance during fast input voltage ramp down tests such as input micro-shorts. The external MOSFET is turned back ON when the voltage across A and C hits  $V_{(AC\_FWD)}$  threshold within  $1.9\text{ }\mu\text{s}$  (typical). For ideal diode only designs, connect LM74720-Q1 as shown in [图 8-1](#).



图 8-1. Configuring LM74720-Q1 for Ideal Diode Only

#### 8.3.1.2 Load Disconnect Switch Control (PD)

PD pin provides a  $50\text{-}\mu\text{A}$  drive and  $88\text{-mA}$  peak pulldown strength for the load disconnect switch stage. Connect the Gate of the FET to PD pin. Place a  $18\text{-V}$  Zener ( $D_z$ ) across the FET gate and source.

For inrush current limiting, connect  $C_{dVdT}$  capacitor and  $R_1$  as shown in [图 8-2](#).

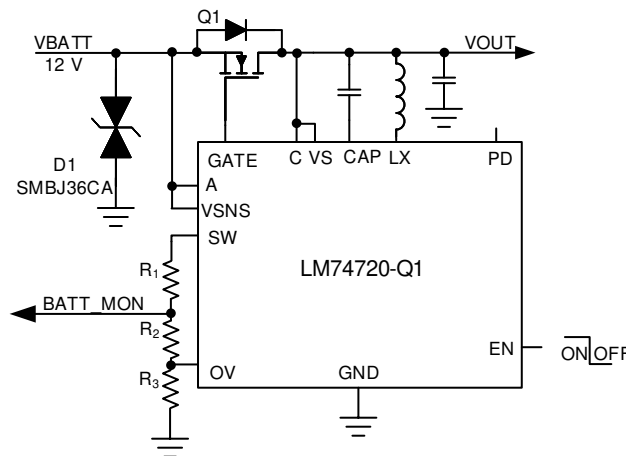

图 8-2. Inrush Current Limiting

The  $C_{dVdT}$  capacitor is required for slowing down the PD voltage ramp during power up for inrush current limiting. Use 方程式 1 to calculate  $C_{dVdT}$  capacitance value.

$$C_{dVdT} = \frac{I_{PD\_DRV}}{I_{INRUSH}} \times C_{OUT} \quad (1)$$

where  $I_{PD\_DRV}$  is 50  $\mu$ A (typical),  $I_{INRUSH}$  is the inrush current, and  $C_{OUT}$  is the output load capacitance. An extra resistor,  $R_1$ , in series with the  $C_{dVdT}$  capacitor improves the turn-off time.

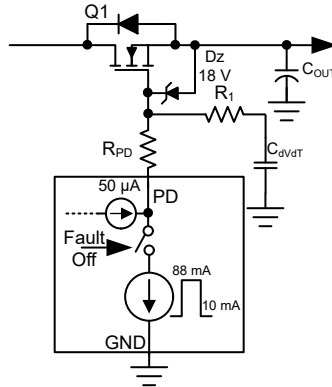
PD is pulled low during the following conditions:

- During an OV event with the OV pin voltage rising above the  $V_{(OVR)}$  threshold
- When the EN pin is pulled low with  $V_{(EN)}$  driven lower than  $V_{(EN\_IL)}$  level
- When the voltage at VS pin drops below the  $V_{(VS\_POR)}$  falling threshold

During these conditions, the FET Q1 turns OFF with its GATE connected to its SOURCE terminal through the external Zener (Dz).

The peak power dissipated in the LM74720-Q1 at the instance of PD pulldown can be calculated approximately using 方程式 2.

$$P_{PD\_peak} = V_{OUT} \times I_{PD\_SINK} \quad (2)$$

where

- $I_{PDSINK\_peak}$  is the peak sink current of 88 mA (typical)

In the system designs with input voltage above 48 V, TI recommends to place a resistor,  $R_{PD}$ , in series with the PD pin as shown in 图 8-2. The peak power dissipation during the pulldown events gets distributed in  $R_{PD}$  and the internal PD switch. A resistor value in the range of 270  $\Omega$  to 330  $\Omega$  can be selected to limit the device power dissipation within the safe limits. 图 6-12 shows the turn-OFF delay characteristics with various resistors.

### 8.3.2 Overvoltage Protection and Battery Voltage Sensing (VSNS, SW, OV)

Connect a resistor ladder as shown in 图 8-3 for overvoltage threshold programming.

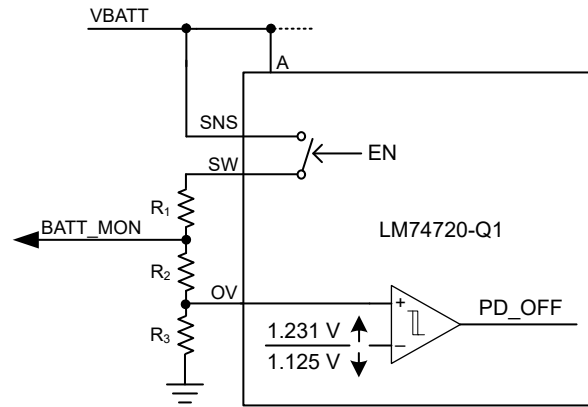

**图 8-3. Programming Overvoltage Threshold and Battery Sensing**

A disconnect switch is integrated between VSNS and SW pins. This switch is turned OFF when EN pin is pulled low. This action helps to reduce the leakage current through the resistor divider network during system shutdown state (IGN\_OFF state).

### 8.3.3 Boost Regulator

The LM74720-Q1 integrates a boost converter to provide voltage necessary to drive the external N-channel MOSFETs for the ideal diode and the load disconnect stages. The boost converter uses hysteretic mode control scheme for the output voltage ( $V_{CAP} - V_{VS}$ ) regulation along with the constant peak inductor current limit ( $I_{LX}$ ). When the CAP - VS voltage is below its nominal value of typically 11.9 V, the low side switch of the boost is turned on and the inductor current rises with the slope of  $VS/L$  approximately. After the current hits the limit of  $I_{LX}$ , that is, 140 mA (typical), then the low side switch is turned off and the inductor current discharges to the output till it reaches zero. The low side switch is turned on again and the switching cycle repeats until the CAP - VS voltage has risen above the boost rising threshold of 13 V (typical). After this threshold level is reached, the boost converter switching is turned OFF to reduce the quiescent current.

For the boost converter to be enabled, the EN pin voltage must be above the specified input high threshold,  $V_{(ENR)}$ . The boost converter has a maximum output load capacity of 29-mA typical. If EN pin is pulled low, then the boost converter remains disabled.

### 8.4 Device Functional Mode (Shutdown Mode)

The LM74720-Q1 enters shutdown mode when the EN pin voltage is below the specified input low threshold,  $V_{(EN\_IL)}$ . Both the gate drivers (GATE and PD) and the boost regulator are disabled in shutdown mode. During shutdown mode, the LM74720-Q1 enters low IQ operation with a total input quiescent consumption of 1.5  $\mu$ A (typical).

## 9 Application and Implementation

### 备注

以下应用部分中的信息不属于 TI 器件规格的范围，TI 不担保其准确性和完整性。TI 的客户应负责确定器件是否适用于其应用。客户应验证并测试其设计，以确保系统功能。

### 9.1 Application Information

LM74720-Q1 controls two N-channel power MOSFETs with GATE used to control diode MOSFET to emulate an ideal diode and PD controlling second MOSFET for power path cut-off when disabled or during an overvoltage protection and provide inrush current limiting. IQ during operation (EN = High) is <math>< 35 \mu\text{A}</math> and <math>< 3.3 \mu\text{A}</math> during shutdown mode (EN = Low). LM74720-Q1 can be placed into low quiescent current mode using EN = low, where both GATE and PD are turned OFF.

### 9.2 Typical 12-V Reverse Battery Protection Application

A typical application circuit of LM74720-Q1 configured to provide reverse battery protection with overvoltage protection and inrush current limiting is shown in 图 9-1.



图 9-1. Typical Application Circuit - 12-V Reverse Battery Protection and Overvoltage Protection

#### 9.2.1 Design Requirements for 12-V Battery Protection

The system design requirements are listed in 表 9-1.

表 9-1. Design Parameters - 12-V Reverse Battery Protection and Overvoltage Protection

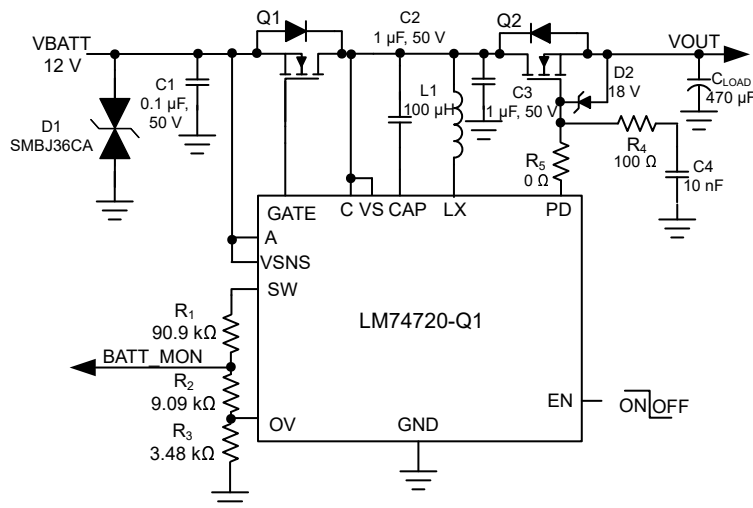
DESIGN PARAMETER	EXAMPLE VALUE
Operating input voltage range	12-V battery, 12-V nominal with 3.2-V cold crank and 35-V load dump
Output power	50 W
Output current range	4-A nominal, 5-A maximum
Input capacitance	0.1-μF minimum
Output capacitance	0.1-μF minimum, (optional 220 μF for E-10 functional class A performance)
Overvoltage cut-off	37 V, output cut-off > 37 V
AC super imposed test	2-V peak-peak 30 kHz, extendable to 6-V peak-peak 30 kHz
Automotive transient immunity compliance	ISO 7637-2, ISO 16750-2 and LV124
Battery monitor ratio	8:1

#### 9.2.2 Automotive Reverse Battery Protection

### 9.2.2.1 Input Transient Protection: ISO 7637-2 Pulse 1

ISO 7637-2 pulse 1 specifies negative transient immunity of electronic modules connected in parallel with an inductive load when the battery is disconnected. A typical pulse 1 specified in ISO 7637-2 starts with battery disconnection where supply voltage collapses to 0 V followed by  $-150\text{ V}$   $2\text{ ms}$  applied with a source impedance of  $10\ \Omega$  at a slew rate of  $1\ \mu\text{s}$  on the supply input. LM74720-Q1 blocks reverse current and prevents the output voltage from swinging negative, protecting the rest of the electronic circuits from damage due to negative transient voltage. MOSFET Q1 is quickly turned off within  $0.5\ \mu\text{s}$  by fast reverse comparator of LM74720-Q1. A single bidirectional TVS is required at the input to clamp the negative transient pulse within the operating maximum voltage across cathode to anode of  $85\text{ V}$  and does not violate the MOSFET Q1 drain-source breakdown voltage rating.

图 9-2 shows ISO 7637-2 pulse 1 performance of LM74720-Q1.



图 9-2. Performance During ISO 7637-2 Pulse 1 Test

### 9.2.2.2 AC Super Imposed Input Rectification: ISO 16750-2 and LV124 E-06

All electronic modules are tested for proper operation with superimposed AC ripple on the DC battery voltage. AC super imposed test specified in ISO 16750-2 and LV124 E-06 requires AC ripple of  $2\text{-V}$  peak-peak on a  $13.5\text{-V}$  DC battery voltage, swept from  $15\text{ Hz}$  to  $30\text{ kHz}$ . LM74720-Q1 rectifies the AC superimposed voltage by turning the MOSFET Q1 OFF quickly to cut off reverse current and turning the MOSFET Q1 ON quickly during forward conduction. Active rectification of  $2\text{-V}$  peak-peak  $5\text{-kHz}$  AC input by LM74720-Q1 is shown in 图 9-3. Fast turn-OFF and quick turn-ON of the MOSFET reduces power dissipation in the MOSFET Q1 and active rectification reduces power dissipation in the output hold-up capacitor's ESR by half. Active rectification of  $2\text{-V}$  peak-peak  $30\text{-kHz}$  AC input is shown in 图 9-4.

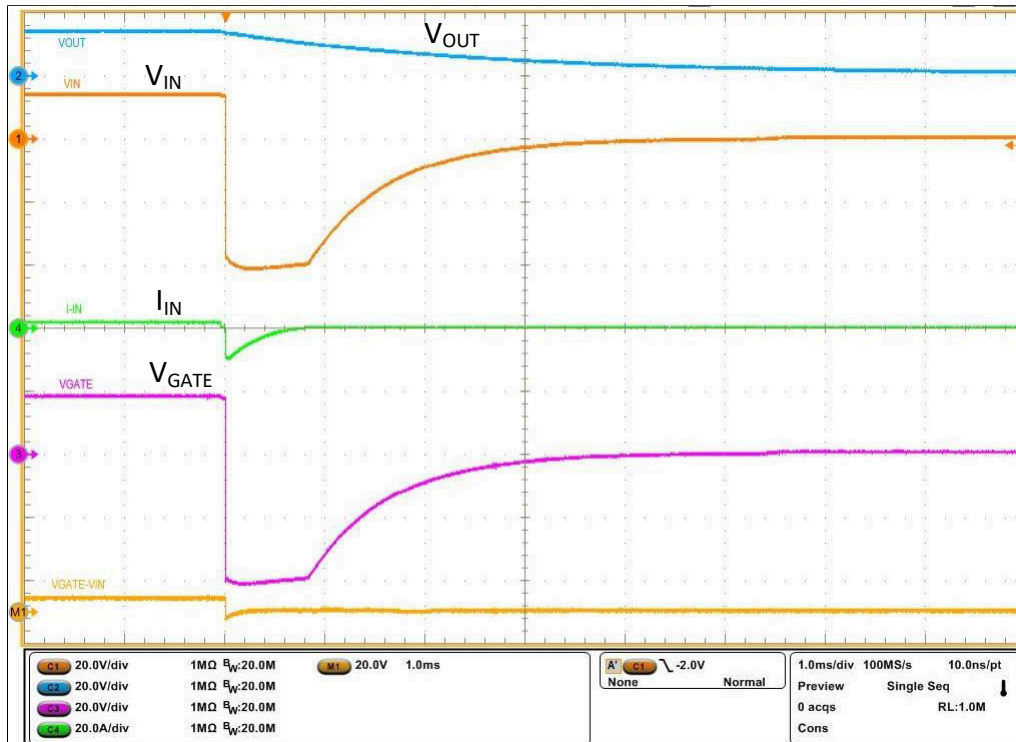

图 9-3. AC Super Imposed Test - 2-V Peak-Peak 5 kHz



图 9-4. AC Super Imposed Test - 2-V Peak-Peak 30 kHz

### 9.2.2.3 Input Micro-Short Protection: LV124 E-10

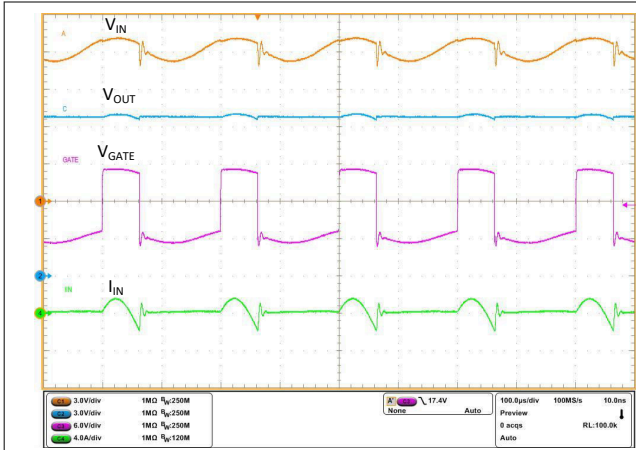
E-10 test specified in LV124 standard checks for immunity of electronic modules to short interruptions in power supply input due to contact issues or relay bounce. During this test (case 2), micro-short is applied on the input for a duration as low as 10  $\mu$ s to several ms. For a functional pass status A, electronic modules are required to run uninterrupted during the E-10 test (case 2) with 100- $\mu$ s duration. When input micro-short is applied for 100  $\mu$ s, LM74720-Q1 quickly turns off MOSFET Q1 by shorting GATE to ANODE (source of MOSFET) within 0.5  $\mu$ s to prevent the output from discharging and the PD remains ON keeping MOSFET Q2 ON, enabling fast recovery after the input short is removed.

图 9-5 shows performance of LM74720-Q1 during E10 input power supply interruption test case 2. After the input short is removed, input voltage recovers and MOSFET Q1 is turned back ON within 200  $\mu$ s. Note that dual-gate drive topology allows MOSFET Q2 to remain ON during the test and helps in restoring the input power faster. Output voltage remains unperturbed during the entire duration, achieving functional status A.

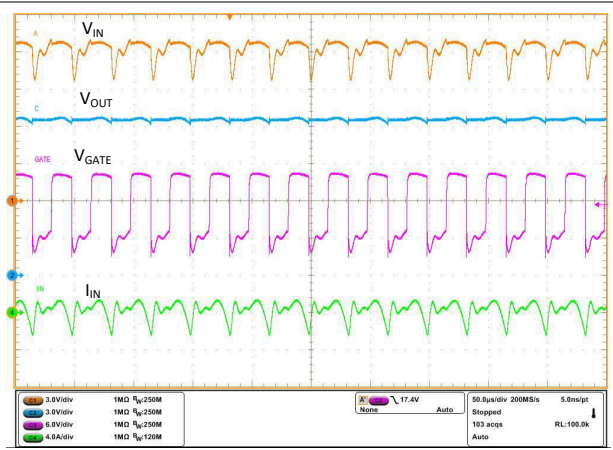

图 9-5. Input Micro-Short - LV124 E10 TC 2 100  $\mu$ s



图 9-6. Input Micro-Short - LV124 E10 TC 2 100  $\mu$ s With PD

## 9.2.3 Detailed Design Procedure

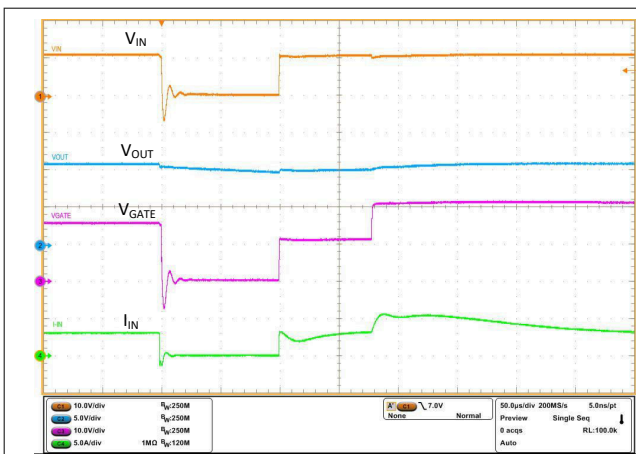
### 9.2.3.1 Design Considerations

表 9-1 summarizes the design parameters that must be known for designing an automotive reverse battery protection circuit with overvoltage cut-off. During power up, inrush current through MOSFET Q2 must be limited so that the MOSFET operates well within its SOA. Maximum load current, maximum ambient temperature, and thermal properties of the PCB determine the  $R_{DS(on)}$  of the MOSFET Q2 and maximum operating voltage determines the voltage rating of the MOSFET Q2. Selection of MOSFET Q2 is determined mainly by the maximum operating load current, maximum ambient temperature, maximum frequency of AC super imposed voltage ripple, and ISO 7637-2 pulse 1 requirements. Overvoltage threshold is decided based on the rating of downstream DC/DC converter or other components after the reverse battery protection circuit. A single bidirectional TVS or two back-back unidirectional TVS are required to clamp input transients to a safe operating level for the MOSFETs Q1, Q2, and LM74720-Q1.

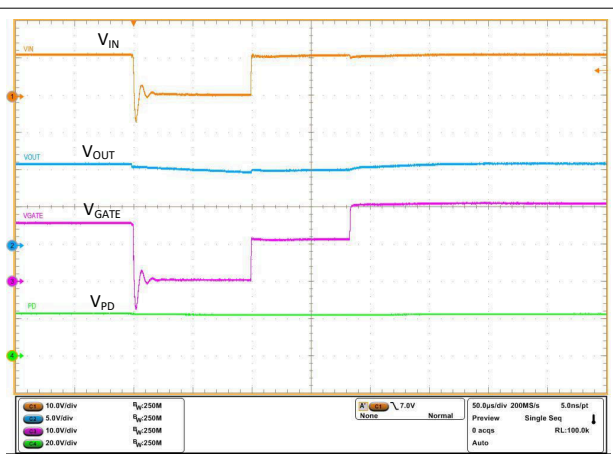
### 9.2.3.2 Boost Converter Components (C2, C3, L1)

Place a minimum of a 1- $\mu$ F capacitor across drain of the FET to GND (C2) and across CAP pin of LM74720- Q1 to drain of the FET (C3). Use a 100- $\mu$ H inductor (L1) with saturation current rating > 175 mA. Example: XPL2010-104ML from coil craft.

### 9.2.3.3 Input and Output Capacitance

TI recommends a minimum input capacitance C1 of 0.1  $\mu$ F and output capacitance  $C_{OUT}$  of 0.1  $\mu$ F.

### 9.2.3.4 Hold-Up Capacitance

Usually bulk capacitors are placed on the output due to various reasons such as uninterrupted operation during power interruption or micro-short at the input, hold-up requirements for doing a memory dump before turning of the module and filtering requirements as well. This design considers minimum bulk capacitors requirements for meeting functional status "A" during LV124 E10 test case 2 100- $\mu$ s input interruption. To achieve functional pass status A, acceptable voltage droop in the output of LM74720-Q1 is based on the UVLO settings of downstream DC/DC converters. For this design, a 1-V drop in output voltage for 100  $\mu$ s is considered and the minimum hold-up capacitance required is calculated by

$$C_{HOLD\_UP\_MIN} = \frac{I_{LOAD\_MAX}}{dV_{OUT}} \times 100\mu s \quad (3)$$

Hold-up capacitance required for 1-V drop in 100  $\mu$ s is 470  $\mu$ F.

### 9.2.3.5 Overvoltage Protection and Battery Monitor

Resistors  $R_1$ ,  $R_2$  and  $R_3$  connected in series are used to program the overvoltage threshold and battery monitor ratio. The resistor values required for setting the overvoltage threshold  $V_{OV}$  to 37 V and battery monitor ratio  $V_{BATT\_MON} : V_{BATT}$  to 1:8 are calculated by solving [Equation 3](#) and [Equation 4](#).

$$V_{OVR} = \frac{R_3}{R_1 + R_2 + R_3} \times V_{OV} \quad (4)$$

$$V_{BAT\_MON} = \frac{R_2 + R_3}{R_1 + R_2 + R_3} \times V_{BATT} \quad (5)$$

For minimizing the input current drawn from the battery through resistors  $R_1$ ,  $R_2$  and  $R_3$ , TI recommends to use higher value of resistance. Using high value resistors adds error in the calculations because the current through the resistors at higher value become comparable to the leakage current into the OV pin. Maximum leakage

current into the OV pin is 1  $\mu\text{A}$  and choosing  $(R_1 + R_2 + R_3) < 120 \text{ k}\Omega$  ensures current through resistors is 100 times greater than leakage through OV pin.

Based on the device electrical characteristics,  $V_{\text{OVR}}$  is 1.23 V and battery monitor ratio ( $V_{\text{BATT\_MON}} / V_{\text{BATT}}$ ) is designed for a ratio of 1:8. To limit  $(R_1 + R_2 + R_3) < 120 \text{ k}\Omega$ , select  $(R_1 + R_2) = 100 \text{ k}\Omega$ . Solving Equation 3 gives  $R_3 = 3.45 \text{ k}\Omega$ . Solving Equation 4 for  $R_2$  using  $(R_1 + R_2) = 100 \text{ k}\Omega$  and  $R_3 = 3.45 \text{ k}\Omega$ , gives  $R_2 = 9.48 \text{ k}\Omega$  and  $R_1 = 90.52 \text{ k}\Omega$ .

Standard 1% resistor values closest to the calculated resistor values are  $R_1 = 90.9 \text{ k}\Omega$ ,  $R_2 = 9.09 \text{ k}\Omega$ , and  $R_3 = 3.48 \text{ k}\Omega$ .

### 9.2.3.6 MOSFET Selection: Blocking MOSFET Q1

For selecting the blocking MOSFET Q1, important electrical parameters are the maximum continuous drain current  $I_D$ , the maximum drain-to-source voltage  $V_{\text{DS(MAX)}}$ , the maximum drain-to-source voltage  $V_{\text{GS(MAX)}}$ , the maximum source current through body diode and the drain-to-source ON resistance  $R_{\text{DS(ON)}}$ .

The maximum continuous drain current,  $I_D$ , rating must exceed the maximum continuous load current.

The maximum drain-to-source voltage,  $V_{\text{DS(MAX)}}$ , must be high enough to withstand the highest differential voltage seen in the application. This action includes all the automotive transient events and any anticipated fault conditions. TI recommends to use MOSFETs with  $V_{\text{DS}}$  voltage rating of 60 V along with a single bidirectional TVS or a  $V_{\text{DS}}$  rating 40-V maximum rating along with two unidirectional TVS connected back-to-back at the input.

The maximum  $V_{\text{GS}}$  LM74720-Q1 can drive is 14 V, so a MOSFET with 15-V minimum  $V_{\text{GS}}$  rating must be selected. If a MOSFET with  $< 15\text{-V}$   $V_{\text{GS}}$  rating is selected, a zener diode can be used to clamp  $V_{\text{GS}}$  to safe level, but this results in increased  $I_Q$  current.

To reduce the MOSFET conduction losses, lowest possible  $R_{\text{DS(ON)}}$  is preferred, but selecting a MOSFET based on low  $R_{\text{DS(ON)}}$  cannot be beneficial always. Higher  $R_{\text{DS(ON)}}$  provides increased voltage information to LM74720-Q1's reverse comparator at a lower reverse current. Reverse current detection is better with increased  $R_{\text{DS(ON)}}$ . Choosing a MOSFET with  $< 50\text{-mV}$  forward voltage drop at maximum current is a good starting point. Based on the design requirements, BUK7Y4R8-60E MOSFET is selected

### 9.2.3.7 MOSFET Selection: Load Disconnect MOSFET Q2

The  $V_{\text{DS}}$  rating of the MOSFET Q2 must be sufficient to handle the maximum system voltage along with the input transient voltage. For this 12-V design, transient overvoltage events are during suppressed load dump 35 V 400 ms and ISO 7637-2 pulse 2 A 50 V for 50  $\mu\text{s}$ . Furthermore, ISO 7637-2 Pulse 3B is a very fast repetitive pulse of 100 V 100 ns that is usually absorbed by the input and output ceramic capacitors and the maximum voltage on the 12-V battery can be limited to  $< 40 \text{ V}$  the minimum recommended input capacitance of 0.1  $\mu\text{F}$ . The 50-V SO 7637-2 Pulse 2 A can also be absorbed by input and output capacitors and its amplitude can be reduced to 40-V peak by placing sufficient amount of capacitance at input and output. Choose a MOSFET with  $\geq 40\text{-V}$   $V_{\text{DS}}$  rating.

The  $V_{\text{GS}}$  rating of the MOSFET Q2 must be higher than that maximum boost drive output of 15.5 V. FET with  $V_{\text{GS}}$  absolute maximum rating of  $\pm 20 \text{ V}$  is selected.

Inrush current through the MOSFET during input hot-plug into the 12-V battery is determined by output capacitance. External capacitor on PD,  $C_{\text{DVDT}}$ , is used to limit the inrush current during input hot-plug or startup. The value of inrush current determined by 方程式 1 must be selected to ensure that the MOSFET Q2 is operating well within its safe operating area (SOA). To limit inrush current to 1.8-A, value of  $C_{\text{DVDT}}$  is 10.43 nF, closest standard value of 10.0 nF is chosen.

Duration of inrush current is calculated by:

$$dT_{\text{INRUSH}} = \frac{12}{I_{\text{INRUSH}}} \times C_{\text{OUT}} \quad (6)$$

Calculated inrush current duration is 3.13 ms with 1.8-A inrush current.

MOSFET BUK7Y4R8-60E having 60-V  $V_{DS}$  and  $\pm 20$ -V  $V_{GS}$  rating is selected for Q2. Power dissipation during inrush is well within the MOSFET's safe operating area (SOA).

#### **9.2.3.8 TVS Selection**

TI recommends a 600-W SMBJ TVS such as SMBJ33CA for input transient clamping and protection. For detailed explanation on TVS selection for 12-V battery systems, refer to [TVS Selection for 12-V Battery Systems](#).





图 9-13. Output Turn-on with Enable



图 9-14. GATE Turn-on with Enable

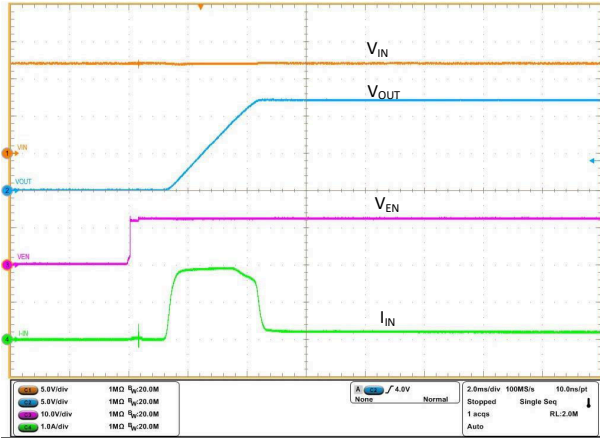

图 9-15. PD Turn-on with Enable

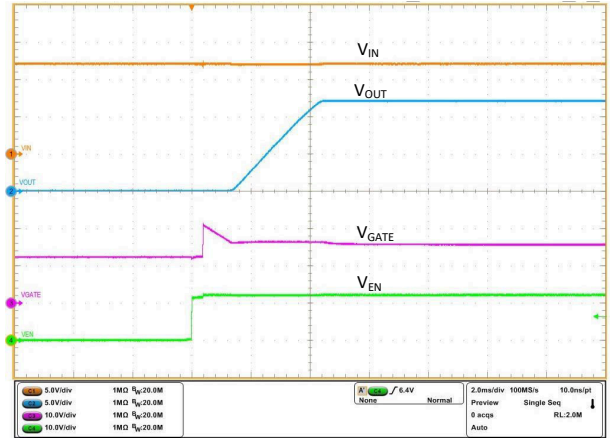

图 9-16. Overvoltage Protection

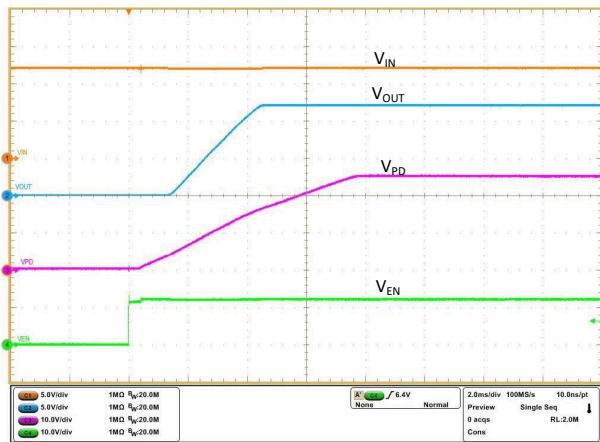

图 9-17. Overvoltage Recovery

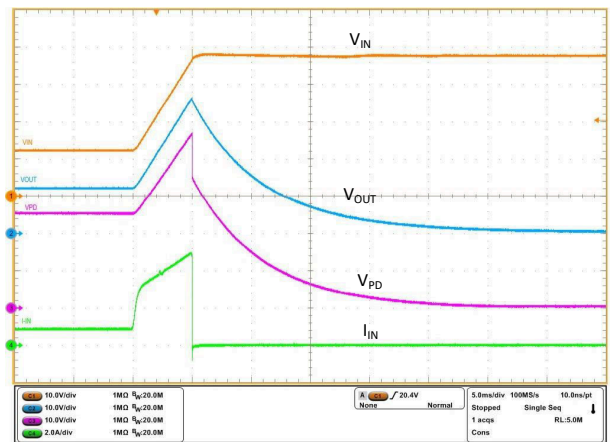

图 9-18. Turn-on Delay - PD

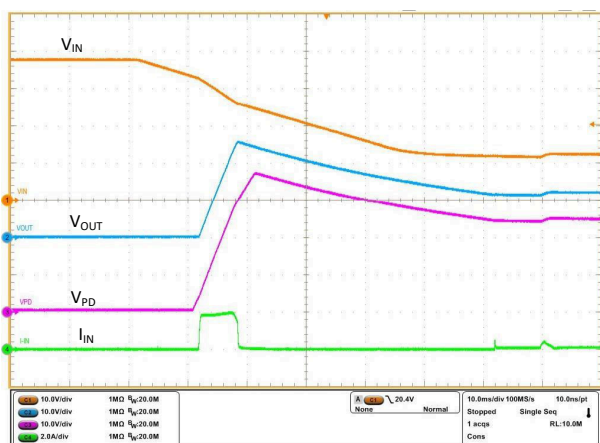

图 9-19. Turn-off Delay - GATE

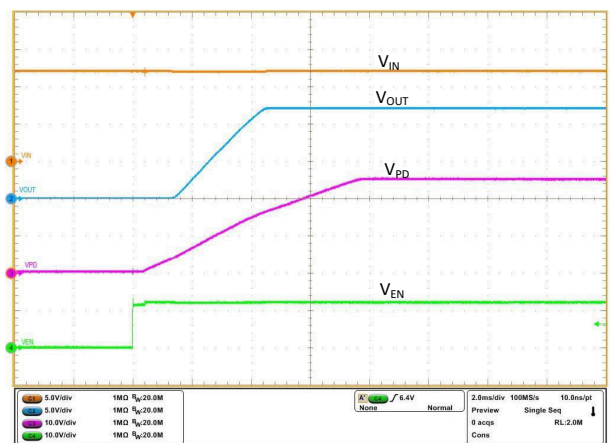

图 9-20. Turn-off Delay - PD

### 9.3 Do's and Don'ts

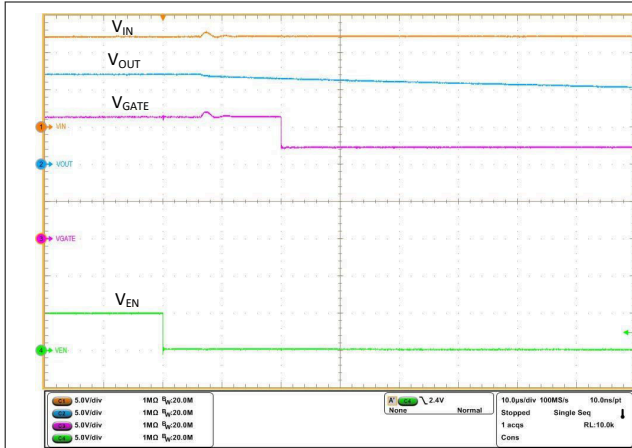
- Leave the exposed pad (RTN) of the IC floating. Do not connect the exposed pad to the GND plane. Connecting RTN to GND disables the reverse polarity protection feature.
- Connect a limiting resistor  $R_{PD}$  in series with the PD pin in the system application designs with input voltage above 48 V. This resistor value can be chosen in the range of 270  $\Omega$  to 330  $\Omega$ .

## 10 Power Supply Recommendations

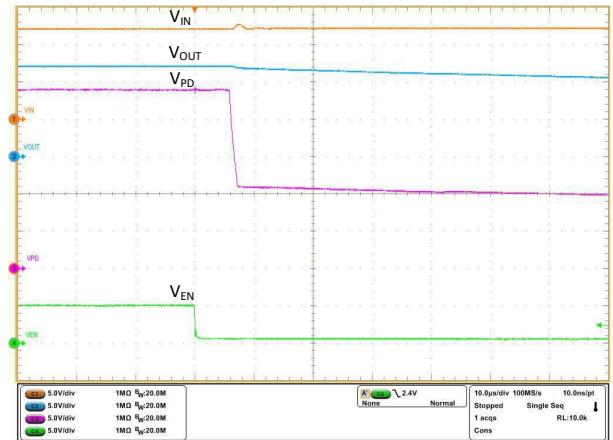
### 10.1 Transient Protection

When the external MOSFETs turn OFF during the conditions, such as overvoltage cut-off, reverse current blocking, EN causing an interruption of the current flow, the input line inductance generates a positive voltage spike on the input and output inductance generates a negative voltage spike on the output. The peak amplitude of voltage spikes (transients) depends on the value of inductance in series to the input or output of the device. These transients can exceed the *Absolute Maximum Ratings* of the device if steps are not taken to address the issue.

Typical methods for addressing transients include:

- Minimizing lead length and inductance into and out of the device
- Using large PCB GND plane
- Using a Schottky diode across the output and GND to absorb negative spikes
- Using a low value ceramic capacitor ( $C_{(IN)}$ ) to approximately  $0.1 \mu\text{F}$  to absorb the energy and dampen the transients.

The approximate value of input capacitance can be estimated with [方程式 7](#).

$$V_{\text{spike(Absolute)}} = V_{(IN)} + I_{(Load)} \times \sqrt{\frac{L_{(IN)}}{C_{(IN)}}} \quad (7)$$

where

- $V_{(IN)}$  is the nominal supply voltage
- $I_{(LOAD)}$  is the load current
- $L_{(IN)}$  equals the effective inductance seen looking into the source
- $C_{(IN)}$  is the capacitance present at the input

Some applications can require additional Transient Voltage Suppressor (TVS) to prevent transients from exceeding the *Absolute Maximum Ratings* of the device. These transients can occur during EMC testing such as automotive ISO7637 pulses.

The circuit implementation with optional protection components (a ceramic capacitor, TVS, and Schottky diode) is shown in [图 10-1](#).

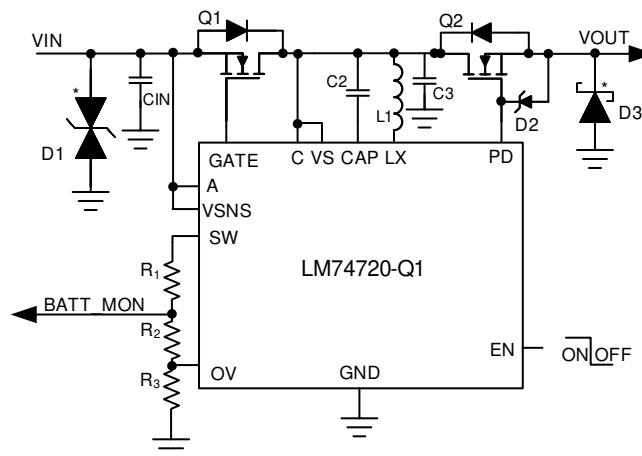

\* Optional components needed for suppression of transients

**图 10-1. Circuit Implementation With Optional Protection Components for LM74720-Q1**

## 10.2 TVS Selection for 12-V Battery Systems

In selecting the TVS, important specifications are breakdown voltage and clamping voltage. The breakdown voltage of the TVS+ must be higher than 24-V jump start voltage and 35-V suppressed load dump voltage and less than the maximum ratings of LM74720-Q1 (65 V). The breakdown voltage of TVS - must be beyond than maximum reverse battery voltage - 16 V, so that the TVS - is not damaged due to long time exposure to reverse connected battery.

Clamping voltage is the voltage the TVS diode clamps in high current pulse situations and this voltage is much higher than the breakdown voltage. In the case of an ISO 7637-2 pulse 1, the input voltage goes up to - 150 V with a generator impedance of  $10 \Omega$ . This action translates to 15 A flowing through the TVS -, and the voltage across the TVS is close to its clamping voltage.

The next criterion is that the absolute maximum rating of cathode to anode voltage of the LM74720-Q1 (85 V) and the maximum  $V_{DS}$  rating MOSFET are not exceeded. In the design example, 60-V rated MOSFET is chosen and maximum limit on the cathode to anode voltage is 60 V.

During ISO 7637-2 pulse 1, the anode of LM74720-Q1 is pulled down by the ISO pulse, clamped by TVS - and the MOSFET Q1 is turned off quickly to prevent reverse current from discharging the bulk output capacitors. When the MOSFET turns off, the cathode to anode voltage seen is equal to (TVS Clamping voltage + Output capacitor voltage). If the maximum voltage on output capacitor is 16 V (maximum battery voltage), then the clamping voltage of the TVS - must not exceed,  $(60 \text{ V} - 16) \text{ V} = -44 \text{ V}$ .

The SMBJ33CA TVS diode can be used for 12-V battery protection application. The breakdown voltage of 36.7 V meets the jump start, load dump requirements on the positive side and 16-V reverse battery connection on the negative side. During ISO 7637-2 pulse 1 test, the SMBJ33CA clamps at - 44 V with 12 A of peak surge current as shown in and it meets the clamping voltage  $\leq 44 \text{ V}$ .

SMBJ series of TVS' are rated up to 600-W peak pulse power levels and are sufficient for ISO 7637-2 pulses.

## 10.3 TVS Selection for 24-V Battery Systems

For 24-V battery protection application, the TVS and MOSFET in [图 9-1](#) must be changed to suit 24-V battery requirements.

The breakdown voltage of the TVS+ must be higher than 48-V jump start voltage, less than the absolute maximum ratings of anode and enable pin of LM74720-Q1 (70 V) and must withstand 65-V suppressed load dump. The breakdown voltage of TVS - must be lower than maximum reverse battery voltage - 32 V, so that the TVS - is not damaged due to long time exposure to reverse connected battery.

During ISO 7637-2 pulse 1, the input voltage goes up to - 600 V with a generator impedance of  $50 \Omega$ . This translates to 12 A flowing through the TVS -. The clamping voltage of the TVS - cannot be same as that of 12-V battery protection circuit. Because during the ISO 7637-2 pulse, the Anode to Cathode voltage seen is equal to ( - TVS Clamping voltage + Output capacitor voltage). For 24-V battery application, the maximum battery voltage is 32 V, then the clamping voltage of the TVS- must not exceed,  $85 \text{ V} - 32 \text{ V} = 53 \text{ V}$ .

Single bidirectional TVS cannot be used for 24-V battery protection because breakdown voltage for TVS+  $\geq 65 \text{ V}$ , maximum clamping voltage is  $\leq 53 \text{ V}$  and the clamping voltage cannot be less than the breakdown voltage. Two un-directional TVS connected back-to-back must be used at the input. For positive side TVS+, TI recommends SMBJ58A with the breakdown voltage of 64.4 V (minimum), 67.8 (typical). For the negative side TVS -, TI recommends SMBJ28A with breakdown voltage close to 32 V (to withstand maximum reverse battery voltage - 32 V) and maximum clamping voltage of 42.1 V.

For 24-V battery protection, TI recommends a 75-V rated MOSFET to be used along with SMBJ28A and SMBJ58A connected back-to-back at the input.

## 11 Layout

### 11.1 Layout Guidelines

- For the ideal diode stage, connect A, GATE and C pins of LM74720-Q1 close to the MOSFET's SOURCE, GATE and DRAIN pins.
- The high current path of for this solution is through the MOSFET; therefore, it is important to use thick and short traces for source and drain of the MOSFET to minimize resistive losses.
- The GATE pin of the LM74720-Q1 must be connected to the MOSFET GATE with short trace.
- Boost converter switching currents flow into LX, CAP, GND pins and C3 (across DRAIN of the FET to GND). The loops formed by capacitor across CAP pin and DRAIN of the FET and C3 to GND must be minimized by placing these capacitors as close as possible. Keep the GND side of the C3 capacitor close to GND pin of LM74720-Q1.
- Place transient suppression components like input TVS and output Schottky close to LM74720-Q1.

### 11.2 Layout Example



图 11-1. LM74720-Q1 Layout Example

## 12 Device and Documentation Support

### 12.1 第三方产品免责声明

TI 发布的与第三方产品或服务有关的信息，不能构成与此类产品或服务或保修的适用性有关的认可，不能构成此类产品或服务单独或与任何 TI 产品或服务一起的表示或认可。

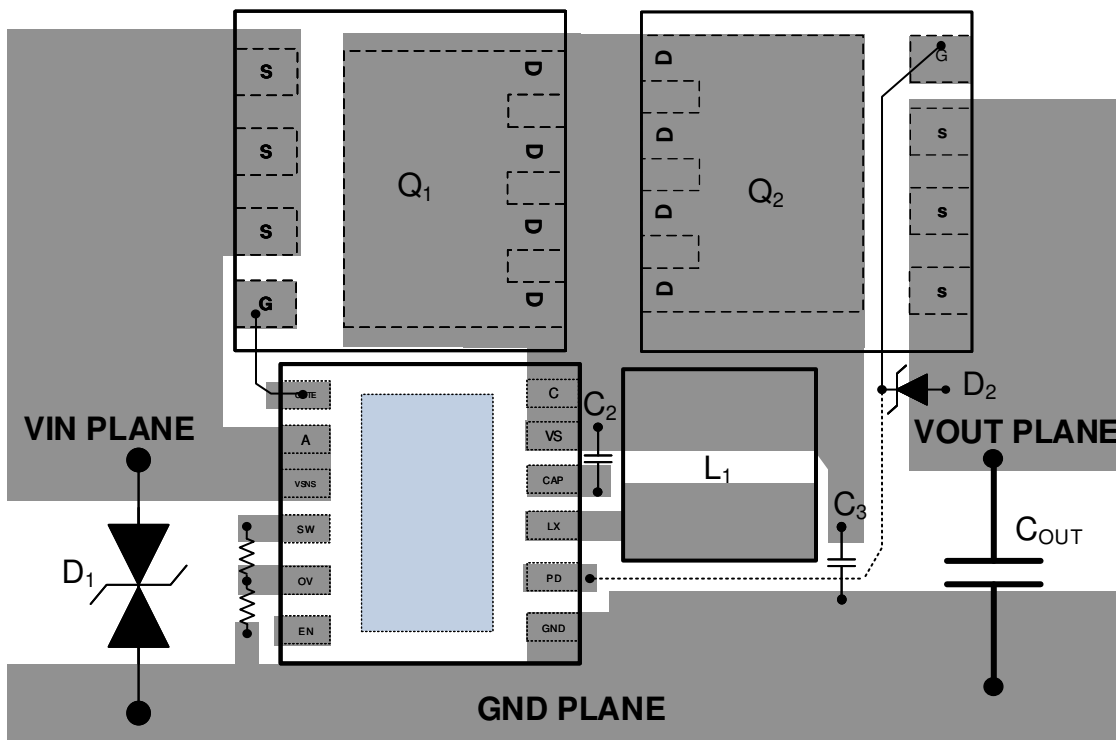
### 12.2 接收文档更新通知

要接收文档更新通知，请导航至 [ti.com](https://www.ti.com) 上的器件产品文件夹。点击 [订阅更新](#) 进行注册，即可每周接收产品信息更改摘要。有关更改的详细信息，请查看任何已修订文档中包含的修订历史记录。

### 12.3 支持资源

[TI E2E™ 支持论坛](#) 是工程师的重要参考资料，可直接从专家获得快速、经过验证的解答和设计帮助。搜索现有解答或提出自己的问题可获得所需的快速设计帮助。

链接的内容由各个贡献者“按原样”提供。这些内容并不构成 TI 技术规范，并且不一定反映 TI 的观点；请参阅 TI 的《[使用条款](#)》。

### 12.4 Trademarks

TI E2E™ is a trademark of Texas Instruments.

所有商标均为其各自所有者的财产。

### 12.5 Electrostatic Discharge Caution



This integrated circuit can be damaged by ESD. Texas Instruments recommends that all integrated circuits be handled with appropriate precautions. Failure to observe proper handling and installation procedures can cause damage.

ESD damage can range from subtle performance degradation to complete device failure. Precision integrated circuits may be more susceptible to damage because very small parametric changes could cause the device not to meet its published specifications.

### 12.6 术语表

[TI 术语表](#) 本术语表列出并解释了术语、首字母缩略词和定义。

## 13 Mechanical, Packaging, and Orderable Information

The following pages include mechanical, packaging, and orderable information. This information is the most current data available for the designated devices. This data is subject to change without notice and revision of this document. For browser-based versions of this data sheet, refer to the left-hand navigation.

**PACKAGING INFORMATION**

Orderable Device	Status (1)	Package Type	Package Drawing	Pins	Package Qty	Eco Plan (2)	Lead finish/ Ball material (6)	MSL Peak Temp (3)	Op Temp (°C)	Device Marking (4/5)	Samples
LM74720QDRRRQ1	ACTIVE	WSON	DRR	12	3000	RoHS & Green	NIPDAU	Level-2-260C-1 YEAR	-40 to 125	L74720	Samples

(1) The marketing status values are defined as follows:

**ACTIVE:** Product device recommended for new designs.

**LIFEBUY:** TI has announced that the device will be discontinued, and a lifetime-buy period is in effect.

**NRND:** Not recommended for new designs. Device is in production to support existing customers, but TI does not recommend using this part in a new design.

**PREVIEW:** Device has been announced but is not in production. Samples may or may not be available.

**OBSOLETE:** TI has discontinued the production of the device.

(2) **RoHS:** TI defines "RoHS" to mean semiconductor products that are compliant with the current EU RoHS requirements for all 10 RoHS substances, including the requirement that RoHS substance do not exceed 0.1% by weight in homogeneous materials. Where designed to be soldered at high temperatures, "RoHS" products are suitable for use in specified lead-free processes. TI may reference these types of products as "Pb-Free".

**RoHS Exempt:** TI defines "RoHS Exempt" to mean products that contain lead but are compliant with EU RoHS pursuant to a specific EU RoHS exemption.

**Green:** TI defines "Green" to mean the content of Chlorine (Cl) and Bromine (Br) based flame retardants meet JS709B low halogen requirements of <=1000ppm threshold. Antimony trioxide based flame retardants must also meet the <=1000ppm threshold requirement.

(3) MSL, Peak Temp. - The Moisture Sensitivity Level rating according to the JEDEC industry standard classifications, and peak solder temperature.

(4) There may be additional marking, which relates to the logo, the lot trace code information, or the environmental category on the device.

(5) Multiple Device Markings will be inside parentheses. Only one Device Marking contained in parentheses and separated by a "-" will appear on a device. If a line is indented then it is a continuation of the previous line and the two combined represent the entire Device Marking for that device.

(6) Lead finish/Ball material - Orderable Devices may have multiple material finish options. Finish options are separated by a vertical ruled line. Lead finish/Ball material values may wrap to two lines if the finish value exceeds the maximum column width.

**Important Information and Disclaimer:**The information provided on this page represents TI's knowledge and belief as of the date that it is provided. TI bases its knowledge and belief on information provided by third parties, and makes no representation or warranty as to the accuracy of such information. Efforts are underway to better integrate information from third parties. TI has taken and continues to take reasonable steps to provide representative and accurate information but may not have conducted destructive testing or chemical analysis on incoming materials and chemicals. TI and TI suppliers consider certain information to be proprietary, and thus CAS numbers and other limited information may not be available for release.

In no event shall TI's liability arising out of such information exceed the total purchase price of the TI part(s) at issue in this document sold by TI to Customer on an annual basis.

## 重要声明和免责声明

TI“按原样”提供技术和可靠性数据（包括数据表）、设计资源（包括参考设计）、应用或其他设计建议、网络工具、安全信息和其他资源，不保证没有瑕疵且不做任何明示或暗示的担保，包括但不限于对适销性、某特定用途方面的适用性或不侵犯任何第三方知识产权的暗示担保。

这些资源可供使用 TI 产品进行设计的熟练开发人员使用。您将自行承担以下全部责任：(1) 针对您的应用选择合适的 TI 产品，(2) 设计、验证并测试您的应用，(3) 确保您的应用满足相应标准以及任何其他功能安全、信息安全、监管或其他要求。

这些资源如有变更，恕不另行通知。TI 授权您仅可将这些资源用于研发本资源所述的 TI 产品的应用。严禁对这些资源进行其他复制或展示。您无权使用任何其他 TI 知识产权或任何第三方知识产权。您应全额赔偿因在这些资源的使用中对 TI 及其代表造成的任何索赔、损害、成本、损失和债务，TI 对此概不负责。

TI 提供的产品受 [TI 的销售条款](#) 或 [ti.com](#) 上其他适用条款/TI 产品随附的其他适用条款的约束。TI 提供这些资源并不会扩展或以其他方式更改 TI 针对 TI 产品发布的适用的担保或担保免责声明。

TI 反对并拒绝您可能提出的任何其他或不同的条款。

邮寄地址：Texas Instruments, Post Office Box 655303, Dallas, Texas 75265

Copyright © 2022，德州仪器 (TI) 公司