

## Ultra-Low Power Dual Operational Amplifiers

### 1 Features

- Low Supply Current: 54  $\mu$ A (Typical)
- Low Offset Voltage: 2 mV (Typical)
- Low Input Bias Current: 2 nA (Typical)
- Input Common-Mode to GND
- Wide Supply Voltage:  $3\text{ V} < V_{CC} < 32\text{ V}$
- Pin Compatible With LM358 and LM2904

### 2 Applications

- LCD Displays
- Portable Instrumentation
- Sensor and Metering Equipment
- Consumer Electronics (MP3 Players, Toys)
- Power Supplies

### 3 Description

The LP358 and LP2904 devices are dual low-power operational amplifiers especially suited for battery-operated applications. Good input specifications and wide supply-voltage range still are achieved despite the ultra-low supply current. Single-supply operation is achieved with an input common-mode range that includes GND.

The LP358 and LP2904 devices are ideal in applications where wide supply voltages and low power are more important than speed and bandwidth. These applications include portable instrumentation, LCD displays, consumer electronics (MP3 players, toys, and so forth), and power supplies.

#### Device Information<sup>(1)</sup>

PART NUMBER	PACKAGE	BODY SIZE (NOM)
LP2904	SOIC (8)	4.90 × 3.91
LP358		

(1) For all available packages, see the orderable addendum at the end of the data sheet.

Symbol (Each Amplifier)

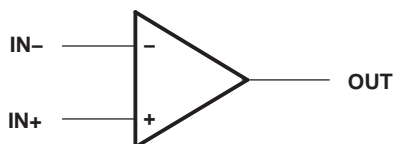

Schematic (Each Amplifier)

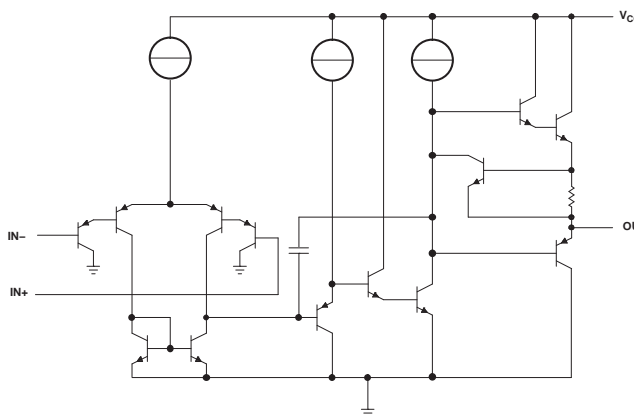

## Table of Contents

<b>1 Features</b> .....	<b>1</b>	8.3 Feature Description .....	<b>8</b>
<b>2 Applications</b> .....	<b>1</b>	8.4 Device Functional Modes .....	<b>8</b>
<b>3 Description</b> .....	<b>1</b>	<b>9 Application and Implementation</b> .....	<b>9</b>
<b>4 Revision History</b> .....	<b>2</b>	9.1 Application Information .....	<b>9</b>
<b>5 Pin Configuration and Functions</b> .....	<b>3</b>	9.2 Typical Application .....	<b>9</b>
<b>6 Specifications</b> .....	<b>4</b>	<b>10 Power Supply Recommendations</b> .....	<b>11</b>
6.1 Absolute Maximum Ratings .....	4	<b>11 Layout</b> .....	<b>12</b>
6.2 ESD Ratings .....	4	11.1 Layout Guidelines .....	12
6.3 Recommended Operating Conditions .....	4	11.2 Layout Example .....	12
6.4 Thermal Information .....	4	<b>12 Device and Documentation Support</b> .....	<b>13</b>
6.5 Electrical Characteristics: LP358 .....	5	12.1 Related Links .....	13
6.6 Electrical Characteristics: LP2904 .....	6	12.2 Receiving Notification of Documentation Updates .....	13
6.7 Operating Characteristics .....	6	12.3 Community Resources .....	13
<b>7 Typical Characteristics</b> .....	<b>7</b>	12.4 Trademarks .....	13
<b>8 Detailed Description</b> .....	<b>8</b>	12.5 Electrostatic Discharge Caution .....	13
8.1 Overview .....	8	12.6 Glossary .....	13
8.2 Functional Block Diagram .....	8	<b>13 Mechanical, Packaging, and Orderable Information</b> .....	<b>14</b>

## 4 Revision History

### Changes from Original (August 2005) to Revision A

Page

• Added table of contents and <i>Revision History</i> section .....	<b>1</b>
• Deleted <i>Ordering Information</i> table .....	<b>1</b>
• Changed low supply current in <i>Features</i> list from 85 $\mu$ A to 54 $\mu$ A .....	<b>1</b>
• Added <i>Device Information</i> table and table note .....	<b>1</b>
• pinout image and pinout information in <i>Pin Configuration and Functions</i> section .....	<b>3</b>
• Deleted $\theta_{JA}$ values and table notes from <i>Absolute Maximum Ratings</i> table and added information to <i>Thermal Information</i> table .....	<b>4</b>
• Added <i>Recommended Operating Conditions</i> table .....	<b>4</b>
• Added <i>Thermal Information</i> table .....	<b>4</b>
• Reformatted <i>Electrical Characteristics</i> table .....	<b>5</b>
• Changed typical supply current value ( $T_A = 25^\circ\text{C}$ ) from 85 $\mu$ A to 54 $\mu$ A in <i>Electrical Characteristics: LP358</i> table .....	<b>5</b>
• Changed maximum supply current value ( $T_A = 25^\circ\text{C}$ ) from 150 $\mu$ A to 75 $\mu$ A in <i>Electrical Characteristics: LP358</i> table .....	<b>5</b>
• Added table note to $I_{OS, VCC}$ parameter in <i>Electrical Characteristics: LP358</i> table .....	<b>5</b>
• Changed typical supply current value ( $T_A = 25^\circ\text{C}$ ) from 85 $\mu$ A to 54 $\mu$ A in <i>Electrical Characteristics: LP2904</i> table .....	<b>6</b>
• Changed maximum supply current value ( $T_A = 25^\circ\text{C}$ ) from 150 $\mu$ A to 75 $\mu$ A in <i>Electrical Characteristics: LP2904</i> table .....	<b>6</b>
• Added table note to $I_{OS, VCC}$ parameter in <i>Electrical Characteristics: LP2904</i> table .....	<b>6</b>
• Added <i>Typical Characteristics</i> graphs .....	<b>7</b>
• Added <i>Detailed Description</i> section .....	<b>8</b>
• Added <i>Application and Implementation</i> section .....	<b>9</b>
• Deleted "of the same magnitude" text from <i>Typical Application</i> section .....	<b>9</b>
• Added <i>Power Supply Recommendations</i> section .....	<b>11</b>
• Added <i>Layout</i> section .....	<b>12</b>
• Added <i>Device and Documentation Support</i> and <i>Mechanical, Packaging, and Orderable Information</i> sections .....	<b>13</b>
• Added <i>Related Links</i> table .....	<b>13</b>

## 5 Pin Configuration and Functions

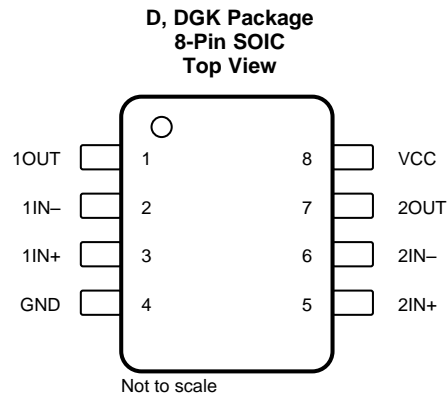

### Pin Functions

PIN		I/O	DESCRIPTION
NAME	NO.		
GND	4	—	Ground or negative power supply
1IN+	3	I	Channel 1 noninverting input
1IN-	2	I	Channel 1 inverting input
1OUT	1	O	Channel 1 output
2IN+	5	I	Channel 2 noninverting input
2IN-	6	I	Channel 2 inverting input
2OUT	7	O	Channel 2 output
V <sub>CC</sub>	8	—	Positive power supply

## 6 Specifications

### 6.1 Absolute Maximum Ratings

over operating free-air temperature range (unless otherwise noted)<sup>(1)</sup>

		MIN	MAX	UNIT
V <sub>CC</sub>	Supply voltage range <sup>(2)</sup>		±16 or 32	V
V <sub>ID</sub>	Differential input voltage <sup>(3)</sup>		±32	V
V <sub>I</sub>	Input voltage (either input)	–0.3	32	V
	Duration of output short circuit (one amplifier) to ground at (or below) T <sub>A</sub> = 25°C, V <sub>CC</sub> ≤ 15 V <sup>(4)</sup>		Unlimited	
Operating virtual temperature, T <sub>J</sub>			150	°C
Storage temperature, T <sub>stg</sub>		–65	150	°C

- (1) Stresses beyond those listed under *Absolute Maximum Ratings* may cause permanent damage to the device. These are stress ratings only, which do not imply functional operation of the device at these or any other conditions beyond those indicated under *Recommended Operating Conditions*. Exposure to absolute-maximum-rated conditions for extended periods may affect device reliability.
- (2) All voltage values (except differential voltages and V<sub>CC</sub> specified for the measurement of I<sub>OS</sub>) are with respect to the network GND.
- (3) Differential voltages are at IN+, with respect to IN–.
- (4) Short circuits from outputs to V<sub>CC</sub> can cause excessive heating and eventual destruction.

### 6.2 ESD Ratings

		VALUE	UNIT
V <sub>(ESD)</sub>	Electrostatic discharge	Human-body model (HBM), per ANSI/ESDA/JEDEC JS-001 <sup>(1)</sup>	±2000
		Charged-device model (CDM), per JEDEC specification JESD22-C101 <sup>(2)</sup>	±1000

- (1) JEDEC document JEP155 states that 500-V HBM allows safe manufacturing with a standard ESD control process. Manufacturing with less than 500-V HBM is possible with the necessary precautions. Pins listed as ±XXX V may actually have higher performance.
- (2) JEDEC document JEP157 states that 250-V CDM allows safe manufacturing with a standard ESD control process. Manufacturing with less than 250-V CDM is possible with the necessary precautions. Pins listed as ±YYY V may actually have higher performance.

### 6.3 Recommended Operating Conditions

over operating free-air temperature range (unless otherwise noted)

		MIN	MAX	UNIT
V <sub>CC</sub>	Supply voltage	3	32	V
V <sub>CM</sub>	Common-mode voltage	0	V <sub>CC</sub> – 1.5 V	V
T <sub>A</sub>	Operating free-air temperature	LP358	0	70
		LP2904	–40	85

### 6.4 Thermal Information

THERMAL METRIC <sup>(1)</sup>		LP358	LP2904	UNIT
		D, DGK (SOIC)	D, DGK (SOIC)	
		8 PINS	8 PINS	
R <sub>θJA</sub>	Junction-to-ambient thermal resistance <sup>(2) (3)</sup>	118.8	118.8	°C/W
R <sub>θJC(top)</sub>	Junction-to-case (top) thermal resistance	71.7	71.7	°C/W
R <sub>θJB</sub>	Junction-to-board thermal resistance	68.6	68.6	°C/W
ψ <sub>JT</sub>	Junction-to-top characterization parameter	23.3	23.3	°C/W
ψ <sub>JB</sub>	Junction-to-board characterization parameter	67.7	67.7	°C/W

- (1) For more information about traditional and new thermal metrics, see the [Semiconductor and IC Package Thermal Metrics](#) application report.
- (2) Maximum power dissipation is a function of T<sub>J(max)</sub>, θ<sub>JA</sub>, and T<sub>A</sub>. The maximum allowable power dissipation at any allowable ambient temperature is P<sub>D</sub> = (T<sub>J(max)</sub> – T<sub>A</sub>) / θ<sub>JA</sub>. Operating at the absolute maximum T<sub>J</sub> of 150°C can affect reliability.
- (3) The package thermal impedance is calculated in accordance with JESD 51-7.

## 6.5 Electrical Characteristics: LP358

 $T_A = 25^\circ\text{C}$ ,  $V_{CC} = 5\text{ V}$ ,  $V_{IC} = V_{CC} / 2$ ,  $R_L = 100\text{ k}\Omega$  to GND (unless otherwise noted)

PARAMETER		TEST CONDITIONS <sup>(1)</sup> <sup>(2)</sup>		MIN	TYP <sup>(3)</sup>	MAX	UNIT
$V_{IO}$	Input offset voltage	$T_A = 25^\circ\text{C}$			2	4	mV
		$T_A = \text{Full range}$				9	
$I_{IB}$	Input bias current	$T_A = 25^\circ\text{C}$			2	10	nA
		$T_A = \text{Full range}$				20	
$I_{IO}$	Input offset current	$T_A = 25^\circ\text{C}$			0.2	2	nA
		$T_A = \text{Full range}$				4	
$A_V$	Large-signal voltage gain	$R_L = 10\text{ k}\Omega$ to GND, $V_{CC} = 30\text{ V}$	$T_A = 25^\circ\text{C}$		50	100	V/mV
			$T_A = \text{Full range}$		40		
CMRR	Common-mode rejection ratio	$V_{CC} = 30\text{ V}$ , $V_{IC} = 0\text{ V}$ to $V_{CC} - 1.5\text{ V}$	$T_A = 25^\circ\text{C}$		80	90	dB
			$T_A = \text{Full range}$		75		
$k_{VSR}$	Power-supply rejection ratio	$V_{CC} = 5\text{ V}$ to $30\text{ V}$	$T_A = 25^\circ\text{C}$		80	90	V
			$T_A = \text{Full range}$		75		
$I_{CC}$	Supply current	$R_L = \infty$	$T_A = 25^\circ\text{C}$		54	75	$\mu\text{A}$
			$T_A = \text{Full range}$			125	
$V_{OH}$	Output voltage swing (high)	$I_L = 0.35\text{ mA}$ to GND $V_{IC} = 0\text{ V}$	$T_A = 25^\circ\text{C}$		3.4	3.6	V
			$T_A = \text{Full range}$		$V_{CC} - 1.9$		
$V_{OL}$	Output voltage swing (low)	$I_L = 0.35\text{ mA}$ from $V_{CC}$ $V_{IC} = 0\text{ V}$	$T_A = 25^\circ\text{C}$		0.82	0.7	V
			$T_A = \text{Full range}$		1		
$I_O$	Output source current	$V_O = 3\text{ V}$ , $V_{ID} = 1\text{ V}$	$T_A = 25^\circ\text{C}$		7	10	mA
			$T_A = \text{Full range}$		4		
$I_O$	Output sink current	$V_O = 1.5\text{ V}$ , $V_{ID} = -1\text{ V}$	$T_A = 25^\circ\text{C}$		4	5	mA
			$T_A = \text{Full range}$		3		
		$V_O = 1.5\text{ V}$ , $V_{ID} = -1\text{ V}$ , $V_{IC} = 0\text{ V}$	$T_A = 25^\circ\text{C}$		2	4	
			$T_A = \text{Full range}$		1		
$I_{OS,GND}$	Output short to GND	$V_{ID} = 1\text{ V}$	$T_A = 25^\circ\text{C}$		20	35	mA
			$T_A = \text{Full range}$			40	
$I_{OS,VCC}$	Output short to $V_{CC}$ <sup>(4)</sup>	$V_{ID} = -1\text{ V}$	$T_A = 25^\circ\text{C}$		15	30	mA
			$T_A = \text{Full range}$			45	
$\alpha V_{IO}$	Input offset voltage drift		$T_A = 25^\circ\text{C}$		10		$\mu\text{V}/^\circ\text{C}$
$\alpha I_{IO}$	Input offset current drift		$T_A = 25^\circ\text{C}$		10		$\text{pA}/^\circ\text{C}$

(1) For full-range temperature limits:  $V_{CC} = 3\text{ V}$  to  $32\text{ V}$ ,  $V_{ICR} = 0\text{ V}$  to  $V_{CC} - 1.5\text{ V}$  (unless otherwise noted)

(2) Full range is  $0^\circ\text{C}$  to  $70^\circ\text{C}$  for LP358.

(3) All typical values are at  $T_A = 25^\circ\text{C}$ .

(4) Short circuits from outputs to  $V_{CC}$  can cause excessive heating and eventual destruction.

### 6.6 Electrical Characteristics: LP2904

T<sub>A</sub> = 25°C, V<sub>CC</sub> = 5 V, V<sub>IC</sub> = V<sub>CC</sub> / 2, R<sub>L</sub> = 100 kΩ to GND (unless otherwise noted)

PARAMETER		TEST CONDITIONS <sup>(1)</sup> <sup>(2)</sup>		MIN	TYP <sup>(3)</sup>	MAX	UNIT
V <sub>IO</sub>	Input offset voltage	T <sub>A</sub> = 25°C			2	4	mV
		T <sub>A</sub> = Full range				10	
I <sub>IB</sub>	Input bias current	T <sub>A</sub> = 25°C			2	20	nA
		T <sub>A</sub> = Full range				40	
I <sub>IO</sub>	Input offset current	T <sub>A</sub> = 25°C			0.5	4	nA
		T <sub>A</sub> = Full range				8	
A <sub>V</sub>	Large-signal voltage gain	R <sub>L</sub> = 10 kΩ to GND, V <sub>CC</sub> = 30 V	T <sub>A</sub> = 25°C	40	70		V/mV
			T <sub>A</sub> = Full range	30			
CMRR	Common-mode rejection ratio	V <sub>CC</sub> = 30 V, V <sub>IC</sub> = 0 V to V <sub>CC</sub> – 1.5 V	T <sub>A</sub> = 25°C	80	90		dB
			T <sub>A</sub> = Full range	75			
k <sub>VSR</sub>	Power-supply rejection ratio	V <sub>CC</sub> = 5 V to 30 V	T <sub>A</sub> = 25°C	80	90		V
			T <sub>A</sub> = Full range	75			
I <sub>CC</sub>	Supply current	R <sub>L</sub> = ∞	T <sub>A</sub> = 25°C		54	75	μA
			T <sub>A</sub> = Full range			138	
V <sub>OH</sub>	Output voltage swing (high)	I <sub>L</sub> = 0.35 mA to GND, V <sub>IC</sub> = 0 V	T <sub>A</sub> = 25°C	3.4	3.6		V
			T <sub>A</sub> = Full range	V <sub>CC</sub> – 1.9			
V <sub>OL</sub>	Output voltage swing (low)	I <sub>L</sub> = 0.35 mA from V <sub>CC</sub> , V <sub>IC</sub> = 0 V	T <sub>A</sub> = 25°C	0.82	0.7		V
			T <sub>A</sub> = Full range	1			
I <sub>O</sub>	Output source current	V <sub>O</sub> = 3 V, V <sub>ID</sub> = 1 V	T <sub>A</sub> = 25°C	7	10		mA
			T <sub>A</sub> = Full range	4			
I <sub>O</sub>	Output sink current	V <sub>O</sub> = 1.5 V, V <sub>ID</sub> = –1 V	T <sub>A</sub> = 25°C	4	5		mA
			T <sub>A</sub> = Full range	3			
		V <sub>O</sub> = 1.5 V, V <sub>ID</sub> = –1 V, V <sub>IC</sub> = 0 V	T <sub>A</sub> = 25°C	2	4		
			T <sub>A</sub> = Full range	1			
I <sub>OS,GND</sub>	Output short to GND	V <sub>ID</sub> = 1 V	T <sub>A</sub> = 25°C		20	35	mA
			T <sub>A</sub> = Full range			40	
I <sub>OS,VCC</sub>	Output short to V <sub>CC</sub> <sup>(4)</sup>	V <sub>ID</sub> = –1 V	T <sub>A</sub> = 25°C		15	30	mA
			T <sub>A</sub> = Full range			45	
αV <sub>IO</sub>	Input offset voltage drift		T <sub>A</sub> = 25°C		10		μV/°C
αI <sub>IO</sub>	Input offset current drift		T <sub>A</sub> = 25°C		10		pA/°C

(1) For full-range temperature limits: V<sub>CC</sub> = 3 V to 32 V, V<sub>ICR</sub> = 0 V to V<sub>CC</sub> – 1.5 V (unless otherwise noted)

(2) Full range is –40°C to +85°C for LP2904.

(3) All typical values are at T<sub>A</sub> = 25°C.

(4) Short circuits from outputs to V<sub>CC</sub> can cause excessive heating and eventual destruction.

### 6.7 Operating Characteristics

over operating free-air temperature range (unless otherwise noted)

		MIN	NOM	MAX	UNIT
GBW	Gain bandwidth product		100		kHz
SR	Slew rate		50		V/ms

## 7 Typical Characteristics

See [Recommended Operating Conditions](#) for device temperature limits.

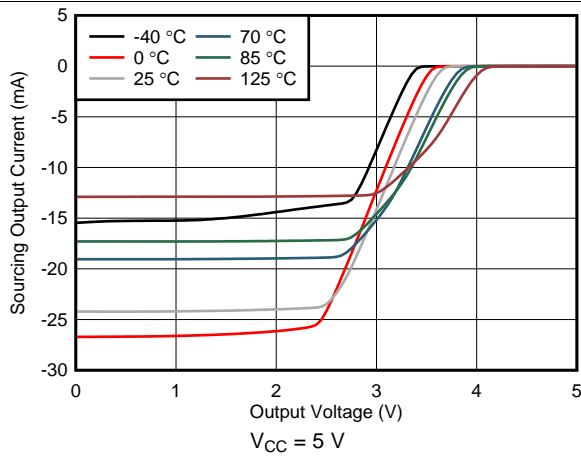

Figure 1. Sourcing Output Current vs Output Voltage

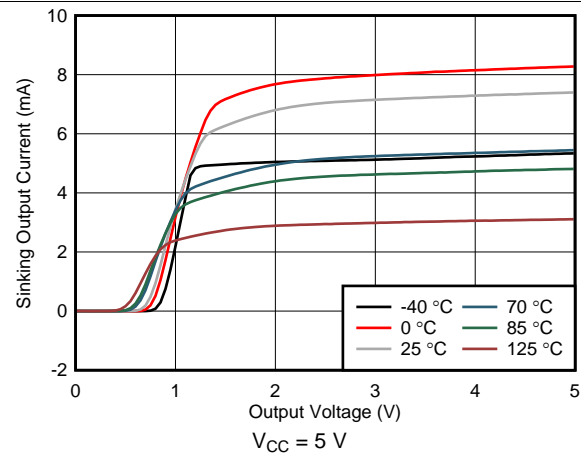

Figure 2. Sinking Output Current vs Output Voltage

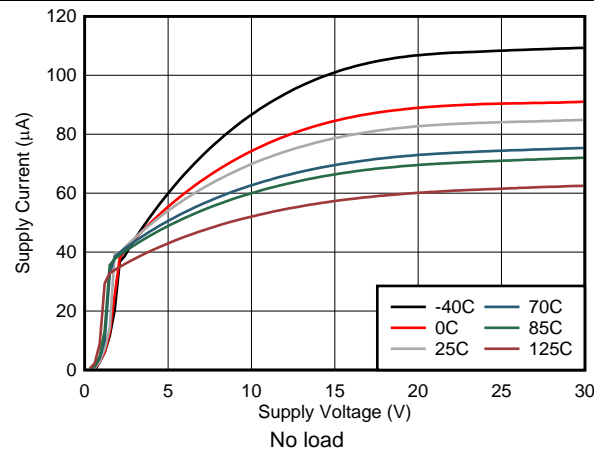

Figure 3. Supply Current vs Supply Voltage

## 8 Detailed Description

### 8.1 Overview

The LP358 and LP2904 devices consist of two independent, low-power, unity-gain, stable operational amplifiers designed to operate from a single supply over a wide range of voltages. Operation from split supplies also is possible. The input voltage range includes ground and extends up to  $V_{CC} - 1.5$  V. The output cannot drive to either rail, however, loads terminated to ground can support  $V_{OL}$  as low as ground. Loads to  $V_{CC}$  can support  $V_{OH}$  as high as  $V_{CC}$ .

### 8.2 Functional Block Diagram

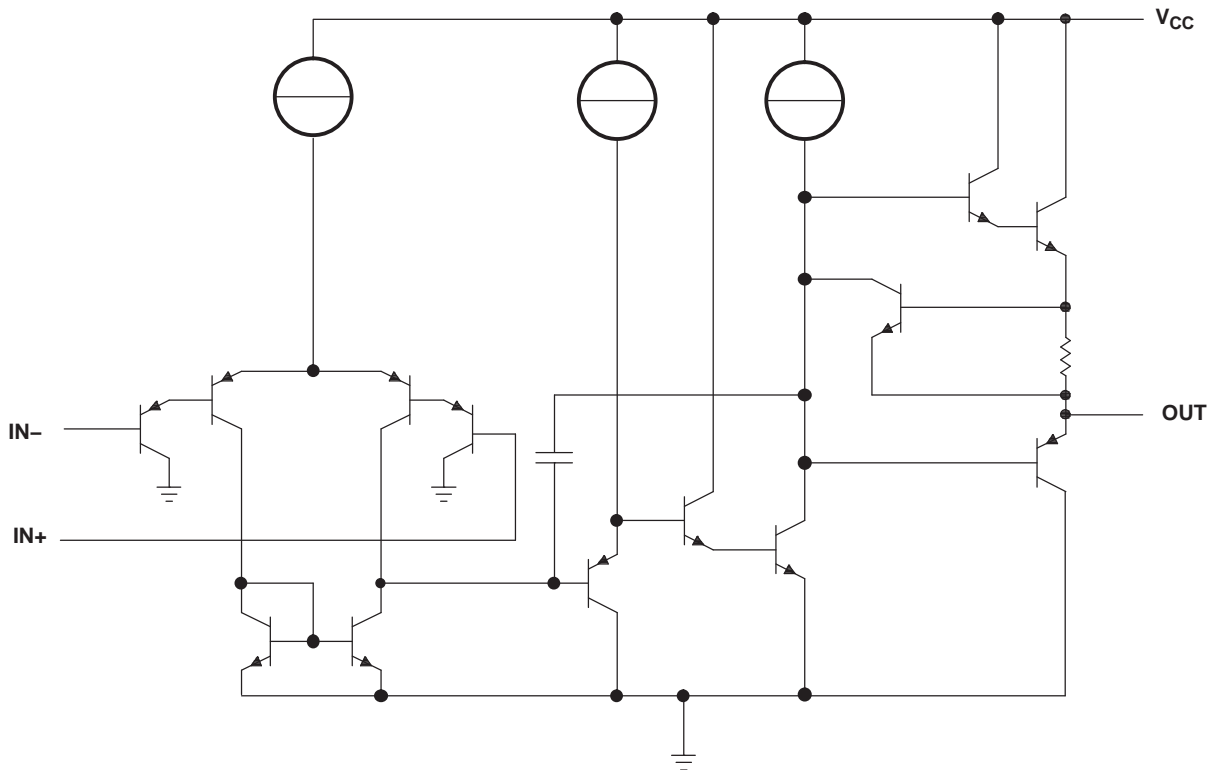

### 8.3 Feature Description

#### 8.3.1 Power Efficient Output Stage

Darlington source driver and emitter follower sink driver will pass bias current through the load to keep device quiescent current independent of load current.

#### 8.3.2 Input Common-Mode Range

The valid common-mode range is from device ground to  $V_{CC} - 1.5$  V. Inputs may exceed  $V_{CC}$  up to the maximum  $V_{CC}$  without device damage. At least one input must be in the valid input common-mode range for output to be correct phase. If both inputs exceed valid range then output phase is undefined. If either input is less than  $-0.3$  V then input current must be limited to 1 mA and output phase is undefined.

### 8.4 Device Functional Modes

These devices are powered on when the supply is connected. This device can be operated as a single-supply operational amplifier or dual-supply amplifier depending on the application.

## 9 Application and Implementation

### NOTE

Information in the following applications sections is not part of the TI component specification, and TI does not warrant its accuracy or completeness. TI's customers are responsible for determining suitability of components for their purposes. Customers should validate and test their design implementation to confirm system functionality.

### 9.1 Application Information

The LP358 and LP2904 operational amplifiers are useful in a wide range of signal conditioning applications due to the wide  $V_{CC}$  range. Inputs can be powered before  $V_{CC}$  for flexibility in multiple supply circuits.

### 9.2 Typical Application

A typical application for an operational amplifier in an inverting amplifier. This amplifier takes a positive voltage on the input, and makes the voltage a negative voltage. In the same manner, the amplifier also makes negative voltages positive.

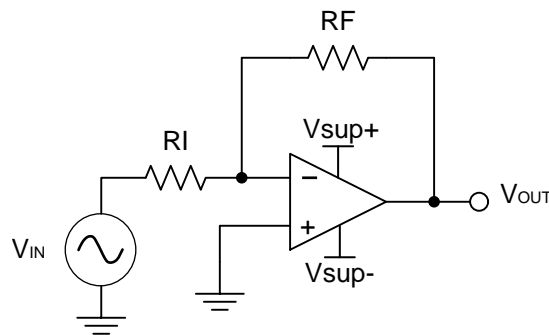

Copyright © 2016, Texas Instruments Incorporated

**Figure 4. Application Schematic**

#### 9.2.1 Design Requirements

The supply voltage must be selected such that it is larger than the input voltage range and output range. For instance, this application scales a signal of  $\pm 0.5$  V to  $\pm 1.8$  V. Setting the supply at  $\pm 12$  V is sufficient to accommodate this application

#### 9.2.2 Detailed Design Procedure

Determine the gain required by the inverting amplifier using [Equation 1](#) and [Equation 2](#).

$$A_V = \frac{V_{OUT}}{V_{IN}} \quad (1)$$

$$A_V = \frac{1.8}{-0.5} = -3.6 \quad (2)$$

Once the desired gain is determined, select a value for  $R_I$  or  $R_F$ . Selecting a value in the  $k\Omega$  range is desirable because the amplifier circuit uses currents in the milliamp range. This ensures the part does not draw too much current. This example uses 10  $k\Omega$  for  $R_I$ , so 36  $k\Omega$  is used for  $R_F$ ; this is determined by [Equation 3](#).

$$A_V = -\frac{R_F}{R_I} \quad (3)$$

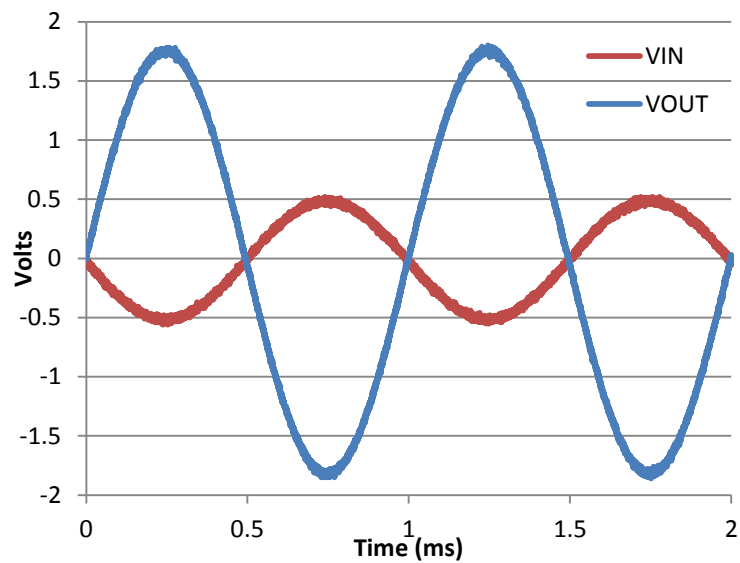
**Typical Application (continued)****9.2.3 Application Curves****Figure 5. Input and Output Voltages of the Inverting Amplifier**

## 10 Power Supply Recommendations

### CAUTION

Supply voltages larger than 32 V can permanently damage the device (see [Absolute Maximum Ratings](#)).

Place 0.1- $\mu$ F bypass capacitors close to the power-supply pins to reduce errors coupling in from noisy or high impedance power supplies. For more detailed information on bypass capacitor placement, see [Layout](#).

## 11 Layout

### 11.1 Layout Guidelines

For best operational performance of the device, use good PCB layout practices, including:

- Noise can propagate into analog circuitry through the power pins of the circuit as a whole, as well as the operational amplifier. Bypass capacitors are used to reduce the coupled noise by providing low impedance power sources local to the analog circuitry.
  - Connect low-ESR, 0.1- $\mu$ F ceramic bypass capacitors between each supply pin and ground, placed as close to the device as possible. A single bypass capacitor from V+ to ground is applicable for single-supply applications.
- Separate grounding for analog and digital portions of circuitry is one of the simplest and most-effective methods of noise suppression. One or more layers on multilayer PCBs are usually devoted to ground planes. A ground plane helps distribute heat and reduces EMI noise pickup. Make sure to physically separate digital and analog grounds, paying attention to the flow of the ground current. For more detailed information, refer to Circuit Board Layout Techniques, (SLOA089).
- To reduce parasitic coupling, run the input traces as far away from the supply or output traces as possible. If it is not possible to keep them separate, it is much better to cross the sensitive trace perpendicular as opposed to in parallel with the noisy trace.
- Place the external components as close to the device as possible. Keeping RF and RG close to the inverting input minimizes parasitic capacitance, as shown in [Layout Example](#).
- Keep the length of input traces as short as possible. Always remember that the input traces are the most sensitive part of the circuit.
- Consider a driven, low-impedance guard ring around the critical traces. A guard ring can significantly reduce leakage currents from nearby traces that are at different potentials.

### 11.2 Layout Example

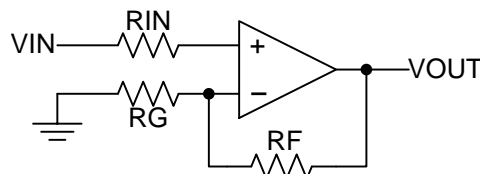

**Figure 6. Operational Amplifier Schematic for Noninverting Configuration**

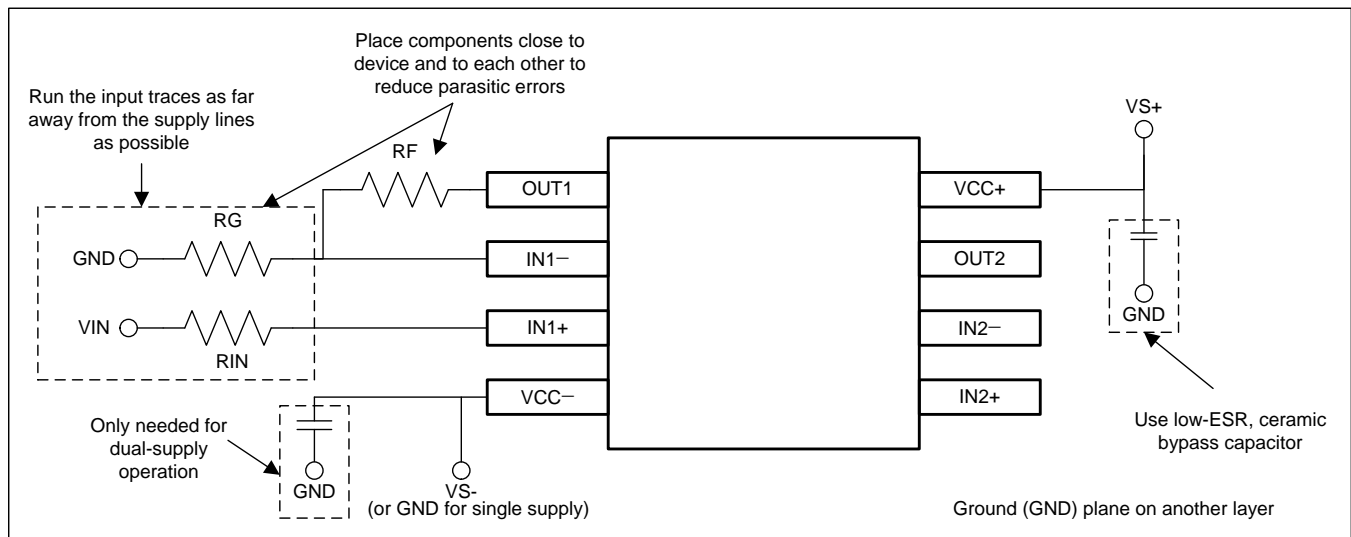

**Figure 7. Operational Amplifier Board Layout for Noninverting Configuration**

## 12 Device and Documentation Support

### 12.1 Related Links

The table below lists quick access links. Categories include technical documents, support and community resources, tools and software, and quick access to sample or buy.

**Table 1. Related Links**

PARTS	PRODUCT FOLDER	ORDER NOW	TECHNICAL DOCUMENTS	TOOLS & SOFTWARE	SUPPORT & COMMUNITY
LP358	<a href="#">Click here</a>	<a href="#">Click here</a>	<a href="#">Click here</a>	<a href="#">Click here</a>	<a href="#">Click here</a>
LP2904	<a href="#">Click here</a>	<a href="#">Click here</a>	<a href="#">Click here</a>	<a href="#">Click here</a>	<a href="#">Click here</a>

### 12.2 Receiving Notification of Documentation Updates

To receive notification of documentation updates, navigate to the device product folder on ti.com. In the upper right corner, click on *Alert me* to register and receive a weekly digest of any product information that has changed. For change details, review the revision history included in any revised document.

### 12.3 Community Resources

The following links connect to TI community resources. Linked contents are provided "AS IS" by the respective contributors. They do not constitute TI specifications and do not necessarily reflect TI's views; see TI's [Terms of Use](#).

**TI E2E™ Online Community** *TI's Engineer-to-Engineer (E2E) Community*. Created to foster collaboration among engineers. At [e2e.ti.com](http://e2e.ti.com), you can ask questions, share knowledge, explore ideas and help solve problems with fellow engineers.

**Design Support** *TI's Design Support* Quickly find helpful E2E forums along with design support tools and contact information for technical support.

### 12.4 Trademarks

E2E is a trademark of Texas Instruments.

### 12.5 Electrostatic Discharge Caution



This integrated circuit can be damaged by ESD. Texas Instruments recommends that all integrated circuits be handled with appropriate precautions. Failure to observe proper handling and installation procedures can cause damage.

ESD damage can range from subtle performance degradation to complete device failure. Precision integrated circuits may be more susceptible to damage because very small parametric changes could cause the device not to meet its published specifications.

### 12.6 Glossary

**SLYZ022** — *TI Glossary*.

This glossary lists and explains terms, acronyms, and definitions.

### 13 Mechanical, Packaging, and Orderable Information

The following pages include mechanical, packaging, and orderable information. This information is the most current data available for the designated devices. This data is subject to change without notice and revision of this document. For browser-based versions of this data sheet, refer to the left-hand navigation.

**PACKAGING INFORMATION**

Orderable Device	Status (1)	Package Type	Package Drawing	Pins	Package Qty	Eco Plan (2)	Lead finish/ Ball material (6)	MSL Peak Temp (3)	Op Temp (°C)	Device Marking (4/5)	Samples
LP2904D	ACTIVE	SOIC	D	8	75	RoHS & Green	NIPDAU	Level-1-260C-UNLIM	-40 to 85	LP2904	<a href="#">Samples</a>
LP2904DR	ACTIVE	SOIC	D	8	2500	RoHS & Green	NIPDAU	Level-1-260C-UNLIM	-40 to 85	LP2904	<a href="#">Samples</a>
LP358D	ACTIVE	SOIC	D	8	75	RoHS & Green	NIPDAU	Level-1-260C-UNLIM	0 to 70	LP358	<a href="#">Samples</a>
LP358DR	ACTIVE	SOIC	D	8	2500	RoHS & Green	NIPDAU	Level-1-260C-UNLIM	0 to 70	LP358	<a href="#">Samples</a>

(1) The marketing status values are defined as follows:

**ACTIVE:** Product device recommended for new designs.

**LIFEBUY:** TI has announced that the device will be discontinued, and a lifetime-buy period is in effect.

**NRND:** Not recommended for new designs. Device is in production to support existing customers, but TI does not recommend using this part in a new design.

**PREVIEW:** Device has been announced but is not in production. Samples may or may not be available.

**OBSELETE:** TI has discontinued the production of the device.

(2) **RoHS:** TI defines "RoHS" to mean semiconductor products that are compliant with the current EU RoHS requirements for all 10 RoHS substances, including the requirement that RoHS substance do not exceed 0.1% by weight in homogeneous materials. Where designed to be soldered at high temperatures, "RoHS" products are suitable for use in specified lead-free processes. TI may reference these types of products as "Pb-Free".

**RoHS Exempt:** TI defines "RoHS Exempt" to mean products that contain lead but are compliant with EU RoHS pursuant to a specific EU RoHS exemption.

**Green:** TI defines "Green" to mean the content of Chlorine (Cl) and Bromine (Br) based flame retardants meet JS709B low halogen requirements of <=1000ppm threshold. Antimony trioxide based flame retardants must also meet the <=1000ppm threshold requirement.

(3) **MSL, Peak Temp.** - The Moisture Sensitivity Level rating according to the JEDEC industry standard classifications, and peak solder temperature.

(4) There may be additional marking, which relates to the logo, the lot trace code information, or the environmental category on the device.

(5) Multiple Device Markings will be inside parentheses. Only one Device Marking contained in parentheses and separated by a "-" will appear on a device. If a line is indented then it is a continuation of the previous line and the two combined represent the entire Device Marking for that device.

(6) **Lead finish/Ball material** - Orderable Devices may have multiple material finish options. Finish options are separated by a vertical ruled line. Lead finish/Ball material values may wrap to two lines if the finish value exceeds the maximum column width.

**Important Information and Disclaimer:**The information provided on this page represents TI's knowledge and belief as of the date that it is provided. TI bases its knowledge and belief on information provided by third parties, and makes no representation or warranty as to the accuracy of such information. Efforts are underway to better integrate information from third parties. TI has taken and

continues to take reasonable steps to provide representative and accurate information but may not have conducted destructive testing or chemical analysis on incoming materials and chemicals. TI and TI suppliers consider certain information to be proprietary, and thus CAS numbers and other limited information may not be available for release.

In no event shall TI's liability arising out of such information exceed the total purchase price of the TI part(s) at issue in this document sold by TI to Customer on an annual basis.

**TAPE AND REEL INFORMATION**

**QUADRANT ASSIGNMENTS FOR PIN 1 ORIENTATION IN TAPE**



\*All dimensions are nominal

Device	Package Type	Package Drawing	Pins	SPQ	Reel Diameter (mm)	Reel Width W1 (mm)	A0 (mm)	B0 (mm)	K0 (mm)	P1 (mm)	W (mm)	Pin1 Quadrant
LP2904DR	SOIC	D	8	2500	330.0	12.4	6.4	5.2	2.1	8.0	12.0	Q1
LP358DR	SOIC	D	8	2500	330.0	12.4	6.4	5.2	2.1	8.0	12.0	Q1

**TAPE AND REEL BOX DIMENSIONS**

\*All dimensions are nominal

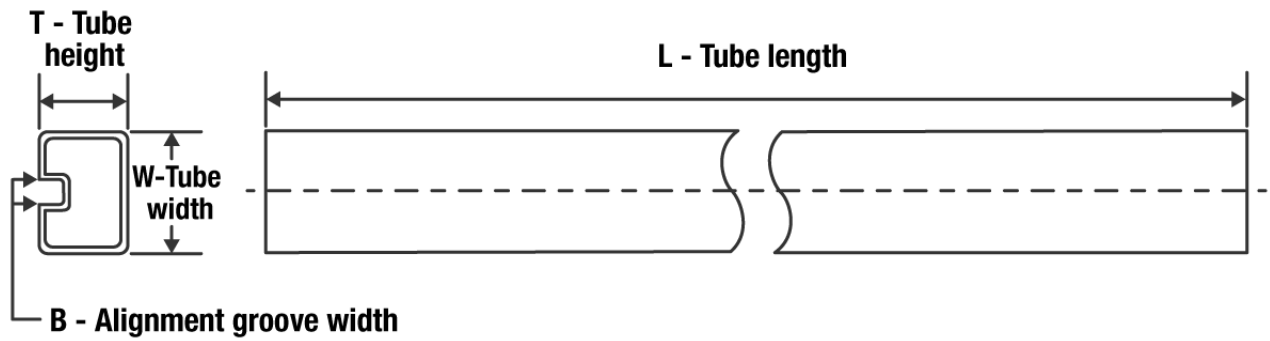
Device	Package Type	Package Drawing	Pins	SPQ	Length (mm)	Width (mm)	Height (mm)
LP2904DR	SOIC	D	8	2500	340.5	336.1	25.0
LP358DR	SOIC	D	8	2500	340.5	336.1	25.0

**TUBE**

\*All dimensions are nominal

Device	Package Name	Package Type	Pins	SPQ	L (mm)	W (mm)	T (μm)	B (mm)
LP2904D	D	SOIC	8	75	507	8	3940	4.32
LP358D	D	SOIC	8	75	507	8	3940	4.32



D0008A

# PACKAGE OUTLINE

SOIC - 1.75 mm max height

SMALL OUTLINE INTEGRATED CIRCUIT



4214825/C 02/2019

NOTES:

1. Linear dimensions are in inches [millimeters]. Dimensions in parenthesis are for reference only. Controlling dimensions are in inches. Dimensioning and tolerancing per ASME Y14.5M.
2. This drawing is subject to change without notice.
3. This dimension does not include mold flash, protrusions, or gate burrs. Mold flash, protrusions, or gate burrs shall not exceed  $.006$  [0.15] per side.
4. This dimension does not include interlead flash.
5. Reference JEDEC registration MS-012, variation AA.

# EXAMPLE BOARD LAYOUT

D0008A

SOIC - 1.75 mm max height

SMALL OUTLINE INTEGRATED CIRCUIT



LAND PATTERN EXAMPLE  
 EXPOSED METAL SHOWN  
 SCALE:8X



SOLDER MASK DETAILS

4214825/C 02/2019

NOTES: (continued)

- 6. Publication IPC-7351 may have alternate designs.
- 7. Solder mask tolerances between and around signal pads can vary based on board fabrication site.

# EXAMPLE STENCIL DESIGN

D0008A

SOIC - 1.75 mm max height

SMALL OUTLINE INTEGRATED CIRCUIT



SOLDER PASTE EXAMPLE  
BASED ON .005 INCH [0.125 MM] THICK STENCIL  
SCALE:8X

4214825/C 02/2019

NOTES: (continued)

8. Laser cutting apertures with trapezoidal walls and rounded corners may offer better paste release. IPC-7525 may have alternate design recommendations.
9. Board assembly site may have different recommendations for stencil design.

## IMPORTANT NOTICE AND DISCLAIMER

TI PROVIDES TECHNICAL AND RELIABILITY DATA (INCLUDING DATA SHEETS), DESIGN RESOURCES (INCLUDING REFERENCE DESIGNS), APPLICATION OR OTHER DESIGN ADVICE, WEB TOOLS, SAFETY INFORMATION, AND OTHER RESOURCES "AS IS" AND WITH ALL FAULTS, AND DISCLAIMS ALL WARRANTIES, EXPRESS AND IMPLIED, INCLUDING WITHOUT LIMITATION ANY IMPLIED WARRANTIES OF MERCHANTABILITY, FITNESS FOR A PARTICULAR PURPOSE OR NON-INFRINGEMENT OF THIRD PARTY INTELLECTUAL PROPERTY RIGHTS.

These resources are intended for skilled developers designing with TI products. You are solely responsible for (1) selecting the appropriate TI products for your application, (2) designing, validating and testing your application, and (3) ensuring your application meets applicable standards, and any other safety, security, regulatory or other requirements.

These resources are subject to change without notice. TI grants you permission to use these resources only for development of an application that uses the TI products described in the resource. Other reproduction and display of these resources is prohibited. No license is granted to any other TI intellectual property right or to any third party intellectual property right. TI disclaims responsibility for, and you will fully indemnify TI and its representatives against, any claims, damages, costs, losses, and liabilities arising out of your use of these resources.

TI's products are provided subject to [TI's Terms of Sale](#) or other applicable terms available either on [ti.com](http://ti.com) or provided in conjunction with such TI products. TI's provision of these resources does not expand or otherwise alter TI's applicable warranties or warranty disclaimers for TI products.

TI objects to and rejects any additional or different terms you may have proposed.

Mailing Address: Texas Instruments, Post Office Box 655303, Dallas, Texas 75265  
Copyright © 2022, Texas Instruments Incorporated