

# 具有四个 150mA 通道的 LP8864S-Q1 汽车显示 LED 背光驱动器

## 1 特性

- 符合面向汽车应用的 AEC-Q100 标准：
  - 器件温度等级 1：
    - 40°C 至 +125°C,  $T_A$
  - 器件 HBM ESD 分类等级 2
  - 器件 CDM ESD 分类等级 C4B
- 输入电压工作范围：3V 至 48V
- 四路高精度电流阱
  - 各电流阱直流电流高达 150mA
  - 电流匹配度为 1% (典型值)
  - 使用 152Hz LED 输出 PWM 频率时，调光比为 32000:1
  - 使用 I2C 或 PWM 输入时，最高 16 位 LED 调光分辨率
  - 可配置 8 个 LED 灯串
- 自动移相 PWM 调光
- 12 位模拟调光
- 最高 48V  $V_{OUT}$  升压或 SEPIC 直流/直流控制器
  - 开关频率为 100kHz 至 2.2MHz
  - 升压扩频功能可降低 EMI
  - 升压同步输入，可通过外部时钟设置升压开关频率
  - 禁用升压时，输出电压自动放电
- 多种故障诊断功能

## 2 应用

- 为以下应用提供背光：
  - 汽车信息娱乐系统
  - 汽车仪表组
  - 智能车镜
  - 抬头显示屏 (HUD)

## 3 说明

LP8864S-Q1 是一款具有升压控制器的汽车类高效 LED 驱动器。四路高精度电流阱支持根据使用的通道数自动调整相移。可通过 I<sup>2</sup>C 接口或 PWM 输入对 LED 亮度进行全局控制。

升压控制器具有基于 LED 电流阱余量电压的自适应输出电压控制。该特性可在所有条件下将升压电压调节到能够满足需要的最低水平，从而更大限度降低功耗。凭借宽范围可调频率，LP8864S-Q1 可避免 AM 无线电频段的干扰。

LP8864S-Q1 支持内置混合 PWM 调光和模拟电流调光，从而可降低 EMI、延长 LED 使用寿命并提高总光学效率。

### 器件信息

器件型号 <sup>(1)</sup>	封装	封装尺寸 (标称值)
LP8864S-Q1	HTSSOP (38)	9.70mm × 4.40mm
	QFN (32) <sup>(2)</sup>	5mm × 5mm

(1) 如需了解所有可用封装，请参阅数据表末尾的可订购产品附录。

(2) 产品预览。

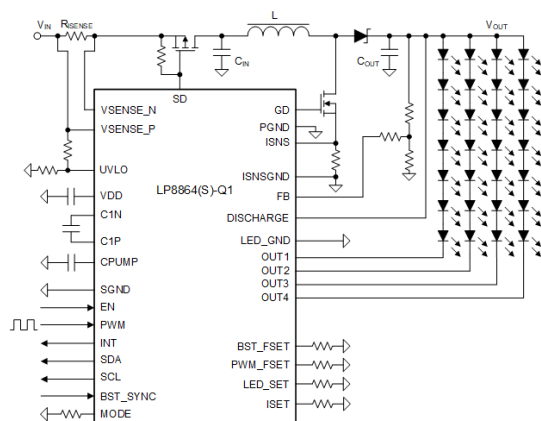

简化版原理图

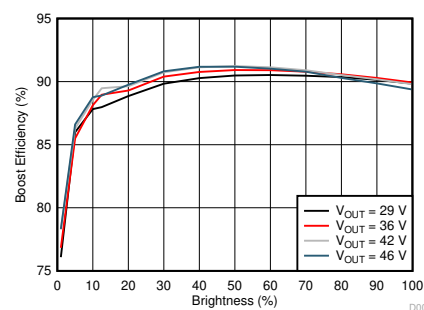

系统效率

D007



## Table of Contents

<b>1 特性</b> .....	1	7.5 Programming.....	39
<b>2 应用</b> .....	1	7.6 Register Maps.....	42
<b>3 说明</b> .....	1	<b>8 Application and Implementation</b> .....	57
<b>4 Revision History</b> .....	2	8.1 Application Information.....	57
<b>5 Pin Configuration and Functions</b> .....	3	8.2 Typical Applications.....	57
<b>6 Specifications</b> .....	6	<b>9 Power Supply Recommendations</b> .....	70
6.1 Absolute Maximum Ratings .....	6	<b>10 Layout</b> .....	71
6.2 ESD Ratings .....	6	10.1 Layout Guidelines.....	71
6.3 Recommended Operating Conditions .....	6	10.2 Layout Example.....	72
6.4 Thermal Information .....	7	<b>11 Device and Documentation Support</b> .....	74
6.5 Electrical Characteristics .....	7	11.1 Device Support.....	74
6.6 Logic Interface Characteristics .....	10	11.2 接收文档更新通知.....	74
6.7 Timing Requirements for I2C Interface .....	10	11.3 支持资源.....	74
6.8 Typical Characteristics.....	11	11.4 Trademarks.....	74
<b>7 Detailed Description</b> .....	12	11.5 静电放电警告.....	74
7.1 Overview.....	12	11.6 术语表.....	74
7.2 Functional Block Diagram.....	13	<b>12 Mechanical, Packaging, and Orderable Information</b> .....	75
7.3 Feature Description.....	13		
7.4 Device Functional Modes.....	38		

## 4 Revision History

注：以前版本的页码可能与当前版本的页码不同

<b>Changes from Revision * (August 2020) to Revision A (February 2021)</b>	<b>Page</b>
• 向“器件信息”表添加了 QFN 封装选项.....	1
• Added QFN package pinout drawing and Pin Functions table.....	3

### 5 Pin Configuration and Functions



图 5-1. DCP Package 38-Pin HTSSOP Top View



Product preview

图 5-2. RHB Package 32-PIN QFN Top View

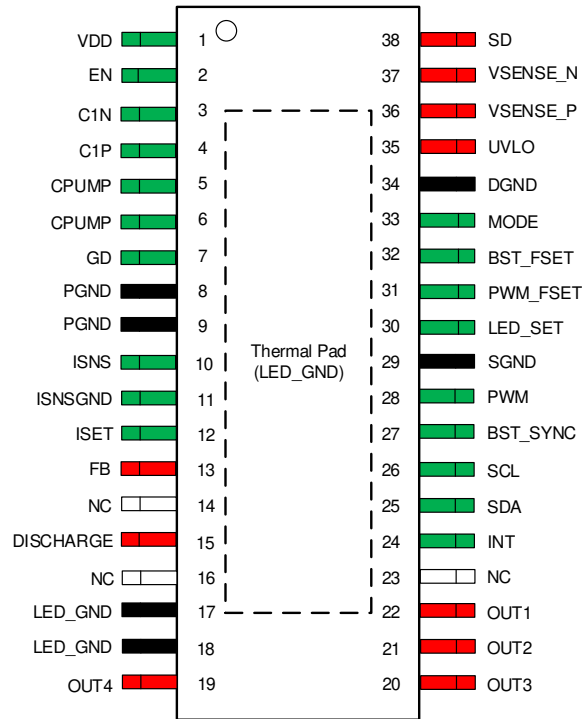
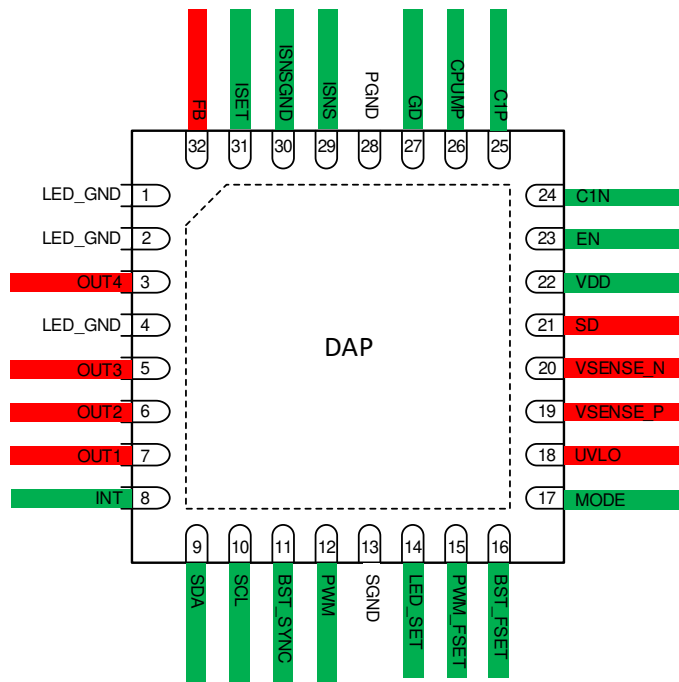
表 5-1. HTTSOP Pin Functions

PIN		TYPE	DESCRIPTION
NO.	NAME		
1	VDD	Power	Power supply input for internal analog and digital circuit. Connect a 10-uF capacitor between the VDD pin to GND.
2	EN	Analog	Enable input.
3	C1N	Analog	Negative input for charge pump flying capacitor. If feature not used leave this pin floating.
4	C1P	Analog	Positive input for charge pump flying capacitor. If feature not used leave this pin floating.
5	CPUMP	Power	Charge pump output pin. Connect to VDD if charge pump is not used. A 4.7 $\mu$ F decoupling capacitor is recommended on CPUMP pin.
6	CPUMP	Power	Charge pump output pin. Always connects with pin 5.
7	GD	Analog	Gate driver output for external N-FET.
8	PGND	GND	Power ground.
9	PGND	GND	Power ground.
10	ISNS	Analog	Boost current sense pin.
11	ISNSGND	GND	Current sense resistor GND.
12	ISET	Analog	LED full-scale current setup through external resistor.
13	FB	Analog	Boost feedback input.
14	NC	N/A	No connect - Leave floating.
15	DISCHARGE	Analog	Boost output voltage discharge pin. Connect to Boost output.
16	NC	N/A	No connect - Leave floating.
17	LED_GND	Analog	LED ground connection.
18	LED_GND	Analog	LED ground connection.
19	OUT4	Analog	LED current sink output. If unused tie to ground.
20	OUT3	Analog	LED current sink output. If unused tie to ground.
21	OUT2	Analog	LED current sink output. If unused tie to ground.
22	OUT1	Analog	LED current sink output. If unused tie to ground.
23	NC	N/A	No connect - Leave floating.
24	INT	Analog	Device fault interrupt output, open drain. A 10-k $\Omega$ pullup resistor is recommended.
25	SDA	Analog	SDA for I2C interface. A 10-k $\Omega$ pullup resistor is recommended.
26	SCL	Analog	SCL for I2C interface. A 10-k $\Omega$ pullup resistor is recommended.
27	BST_SYNC	Analog	Input for synchronizing boost. When synchronization is not used, connect this pin to ground to disable spread spectrum or to VDD to enable spread spectrum.
28	PWM	Analog	PWM input for brightness control. Tie to GND if unused.
29	SGND	GND	Signal ground.
30	LED_SET	Analog	LED string configuration through external resistor. Do not leave floating.
31	PWM_FSET	Analog	LED dimming frequency setup through external resistor. Do not leave floating.
32	BST_FSET	Analog	Boost switching frequency setup through external resistor. Do not leave floating.
33	MODE	Analog	Dimming mode setup through external resistor. Do not leave floating.
34	DGND	GND	Digital ground.
35	UVLO	Analog	Input voltage sense for programming input UVLO threshold through external resistor to VIN.
36	VSENSE_P	Analog	Pin for input voltage detection for OVP protection and positive input for input current sense.
37	VSENSE_N	Analog	Negative input for input current sense. If input current sense is not used, please tie to VSENSE_P pin.
38	SD	Analog	Power line FET control. Open Drain output. If unused, leave this pin floating.
DAP	LED_GND	GND	LED ground connection.

**表 5-2. QFN Pin Functions**

PIN		TYPE	DESCRIPTION
NO.	NAME		
1	LED_GND	Analog	LED ground connection.
2	LED_GND	Analog	LED ground connection.
3	OUT4	Analog	LED current sink output. If unused tie to ground.
4	LED_GND	GND	LED ground connection.
5	OUT3	Analog	LED current sink output. If unused tie to ground.
6	OUT2	Analog	LED current sink output. If unused tie to ground.
7	OUT1	Analog	LED current sink output. If unused tie to ground.
8	INT	Analog	Device fault interrupt output, open drain. A 10-k $\Omega$ pullup resistor is recommended.
9	SDA	Analog	SDA for I2C interface. A 10-k $\Omega$ pullup resistor is recommended.
10	SCL	Analog	SCL for I2C interface. A 10-k $\Omega$ pullup resistor is recommended.
11	BST_SYNC	Analog	Input for synchronizing boost. When synchronization is not used, connect this pin to ground to disable spread spectrum or to VDD to enable spread spectrum.
12	PWM	Analog	PWM input for brightness control. Tie to GND if unused.
13	SGND	GND	Signal ground.
14	LED_SET	Analog	LED string configuration through external resistor. Do not leave floating.
15	PWM_FSET	Analog	LED dimming frequency setup through external resistor. Do not leave floating.
16	BST_FSET	Analog	Boost switching frequency setup through external resistor. Do not leave floating.
17	MODE	Analog	Dimming mode setup through external resistor. Do not leave floating.
18	UVLO	Analog	Input voltage sense for programming input UVLO threshold through external resistor to VIN.
19	VSENSE_P	Analog	Pin for input voltage detection for OVP protection and positive input for input current sense.
20	VSENSE_N	Analog	Negative input for input current sense. If input current sense is not used, please tie to VSENSE_P pin.
21	SD	Analog	Power line FET control. Open Drain output. If unused, leave this pin floating.
22	VDD	Power	Power supply input for internal analog and digital circuit. Connect a 10-uF capacitor between the VDD pin to GND
23	EN	Analog	Enable input.
24	C1N	Analog	Negative input for charge pump flying capacitor. If feature not used leave this pin floating.
25	C1P	Analog	Positive input for charge pump flying capacitor. If feature not used leave this pin floating.
26	CPUMP	Power	Charge pump output pin. Connect to VDD if charge pump is not used. A 4.7- $\mu$ F decoupling capacitor is recommended on CPUMP pin.
27	GD	Analog	Gate driver output for external N-FET.
28	PGND	GND	Power ground.
29	ISNS	Analog	Boost current sense pin.
30	ISNSGND	GND	Current sense resistor GND.
31	ISET	Analog	LED full-scale current setup through external resistor.
32	FB	Analog	Boost feedback input.
DAP	LED_GND	GND	LED ground connection.

## 6 Specifications

### 6.1 Absolute Maximum Ratings

over operating free-air temperature range (unless otherwise noted)<sup>(1)</sup> <sup>(2)</sup>

		MIN	MAX	UNIT
Voltage on pins	VSENSE_N, SD, UVLO	-0.3	VSENSE_P + 0.3	V
Voltage on pins	VSENSE_P, FB, DISCHARGE, OUT1 to OUT4	-0.3	52	V
	C1N, C1P, VDD, EN, ISNS, ISNS_GND, INT, MODE, PWM_FSET, BST_FSET, LED_SET, ISET, GD and CPUMP	-0.3	6	V
Voltage on pins	PWM, BST_SYNC, SDA, SCL	-0.3	VDD + 0.3	V
	Continuous power dissipation <sup>(3)</sup>		Internally Limited	W
Thermal	Ambient temperature, T <sub>A</sub> <sup>(4)</sup>	-40	125	
	Junction temperature, T <sub>J</sub> <sup>(4)</sup>	-40	150	°C
	Lead temperature (soldering)		260	°C
	Storage temperature, T <sub>stg</sub>	-65	150	°C

- Stresses beyond those listed under *Absolute Maximum Rating* may cause permanent damage to the device. These are stress ratings only, which do not imply functional operation of the device at these or any other conditions beyond those indicated under *Recommended Operating Condition*. Exposure to absolute-maximum-rated conditions for extended periods may affect device reliability.
- All voltages are with respect to the potential at the GND pins.
- Internal thermal shutdown circuitry protects the device from permanent damage. Thermal shutdown engages at T<sub>J</sub> = 165°C (typical) and disengages at T<sub>J</sub> = 150°C (typical).
- In applications where high power dissipation and/or poor package thermal resistance is present, the maximum ambient temperature may have to be derated. Maximum ambient temperature (T<sub>A-MAX</sub>) is dependent on the maximum operating junction temperature (T<sub>J-MAX</sub> = 150°C), the power dissipation of the device in the application (P), the junction-to-board thermal resistance and the temperature difference between the system board and the ambient (Δt<sub>BA</sub>), which is given by the following equation: T<sub>A-MAX</sub> = T<sub>J-MAX</sub> - (P × R<sub>JB</sub>) - Δt<sub>BA</sub>.

### 6.2 ESD Ratings

		VALUE	UNIT	
V <sub>(ESD)</sub>	Electrostatic discharge	Human body model (HBM), per AEC Q100-002 <sup>(1)</sup>	±2000	
		Charged device model (CDM), per AEC Q100-011	Corner pins (1, 19, 20 and 38)	±750
			Other pins	±500

- AEC Q100-002 indicates that HBM stressing shall be in accordance with the ANSI/ESDA/JEDEC JS-001 specification.

### 6.3 Recommended Operating Conditions

over operating free-air temperature range (unless otherwise noted)<sup>(1)</sup>

		MIN	NOM	MAX	UNIT
Voltage on pins	VSENSE_P, VSENSE_N, SD, UVLO	3	12	48	V
	FB, OUT1 to OUT4	0		48	
	ISNS, ISNSGND	0		5.5	
	EN, PWM, INT, SDA, SCL, BST_SYNC	0	3.3	5.5	
	VDD	3	3.3/5	5.5	
	C1N, C1P, CPUMP, GD	0	5	5.5	
Thermal	Ambient temperature, T <sub>A</sub>	-40		125	°C

- All voltages are with respect to the potential at the GND pins.

## 6.4 Thermal Information

THERMAL METRIC <sup>(1)</sup>		Device	UNIT
		HTTSOP	
		38-PIN	
R <sub>θJA</sub>	Junction-to-ambient thermal resistance <sup>(2)</sup>	32.4	°C/W
R <sub>θJC(top)</sub>	Junction-to-case (top) thermal resistance	19.5	
R <sub>θJB</sub>	Junction-to-board thermal resistance	8.8	
Ψ <sub>JT</sub>	Junction-to-top characterization parameter	0.3	
Ψ <sub>JB</sub>	Junction-to-board characterization parameter	8.9	
R <sub>θJC(bot)</sub>	Junction-to-case (bottom) thermal resistance	2.7	

- (1) For more information about traditional and new thermal metrics, see the [Semiconductor and IC Package Thermal Metrics](#) application report.
- (2) Junction-to-ambient thermal resistance is highly application and board-layout dependent. In applications where high maximum power dissipation exists, special care must be paid to thermal dissipation issues in board design.

## 6.5 Electrical Characteristics

Limits apply over the full operation temperature range  $-40^{\circ}\text{C} \leq T_A \leq +125^{\circ}\text{C}$ , unless otherwise specified. V<sub>IN</sub> = 12 V, V<sub>DD</sub> = 3.3 V

PARAMETER		TEST CONDITIONS	MIN	TYP	MAX	UNIT
<b>General Electrical Characteristics</b>						
I <sub>Q</sub>	Shutdown mode current, VDD pin	EN = L		1	5	μA
I <sub>Q</sub>	Active mode current, VDD pin <sup>(1)</sup>	FSW = 303kHz, PWM = H, BOOST-FET IPD25N06S4L-30, Charge Pump Disabled		15	65	mA
I <sub>Q</sub>	Active mode current, VDD pin <sup>(1)</sup>	FSW = 2200kHz, PWM = H, BOOST-FET IPD25N06S4L-30, Charge Pump Disabled		40	75	mA
I <sub>Q</sub>	Active mode current, VDD pin <sup>(1)</sup>	FSW = 303kHz, PWM = H, BOOST-FET IPD25N06S4L-30, Charge Pump Enabled		20	91	mA
I <sub>Q</sub>	Active mode current, VDD pin <sup>(1)</sup>	FSW = 2200kHz, PWM = H, BOOST-FET IPD25N06S4L-30, Charge Pump Enabled		65	104	mA
<b>CPUMP and LDO Electrical Characteristics</b>						
V <sub>CPUMP</sub>	Voltage accuracy	V <sub>DD</sub> = 3.0 to 3.6 V; I <sub>LOAD</sub> = 1 to 50 mA	4.8	5	5.2	V
f <sub>CP</sub>	CP switching frequency		387	417	447	kHz
V <sub>CPUMP_UVLO</sub>	VCPUMP UVLO threshold	V <sub>CPUMP</sub> falling edge	3.95	4.2	4.4	V
V <sub>CPUMP_UVLO</sub>	VCPUMP UVLO threshold	V <sub>CPUMP</sub> rising edge	4.15	4.4	4.6	V
V <sub>CPUMP_HYS</sub>	VCPUMP UVLO hysteresis		0.1	0.2		V
T <sub>START_UP</sub>	Charge pump startup time	C <sub>CPUMP</sub> = 10 μF		1000	2000	μs
<b>Protection Electrical Characteristics</b>						
V <sub>DD_UVLO_F</sub>	V <sub>DD</sub> UVLO threshold	V <sub>DD</sub> falling	2.68	2.8	2.92	V
V <sub>DD_UVLO_R</sub>	V <sub>DD</sub> UVLO threshold	V <sub>DD</sub> rising			3.0	V
V <sub>DD_UVLO_H</sub>	V <sub>DD</sub> UVLO hysteresis			0.1		V
V <sub>IN_UVLO_TH</sub>	UVLO pin threshold	V <sub>UVLO</sub> falling	0.753	0.777	0.801	V
I <sub>UVLO</sub>	UVLO pin bias current	V <sub>UVLO</sub> = V <sub>UVLO_TH</sub> + 50 mV		-5		μA

## 6.5 Electrical Characteristics (continued)

Limits apply over the full operation temperature range  $-40^{\circ}\text{C} \leq T_A \leq +125^{\circ}\text{C}$ , unless otherwise specified.  $V_{IN} = 12\text{ V}$ ,  $V_{DD} = 3.3\text{ V}$

PARAMETER		TEST CONDITIONS	MIN	TYP	MAX	UNIT
$V_{IN\_OVP\_TH}$	OVP threshold	$V_{SENSE\_P}$ rising	40.8	43	45.2	V
$V_{IN\_OVP\_HYS}$	OVP hysteresis			1.7		V
$V_{IN\_OCP\_TH}$	Input OCP threshold	$R_{ISENSE} = 20\text{ m}\Omega$	187	220	253	mV
$T_{SD}$	Thermal shutdown threshold <sup>(1)</sup>	Temperature rising	150	165	180	$^{\circ}\text{C}$
$T_{SD}$	Thermal shutdown hysteresis <sup>(1)</sup>			20		$^{\circ}\text{C}$
$I_{SD\_LEAKAGE}$	SD leakage current	$V_{SD} = 48\text{ V}$		1		$\mu\text{A}$
$I_{SD}$	SD pull down current	$R_{SD} = 20\text{ k}\Omega$	250	325	400	$\mu\text{A}$
$V_{FB\_OVPL}$	FB pin - Boost OVP low threshold			1.423		V
$V_{FB\_OVPH}$	FB pin - Boost OVP high threshold			1.76		V
$V_{FB\_UVP}$	FB pin - Boost OCP threshold			0.886		V
$V_{BST\_OVPH}$	Discharge pin - Boost OVP high threshold		48.5	50	51.8	V
<b>Input PWM Electrical Characteristics</b>						
$I_{PWM\_LEAKAGE}$	PWM leakage current	$V_{PWM} = 5\text{ V}$		1		$\mu\text{A}$
$f_{PWM\_IN}$	PWM input frequency		100		20000	Hz
$t_{PWM\_MIN\_ON}$	PWM input minimum on-time	Direct PWM mode			200	ns
$t_{PWM\_MIN\_ON}$	PWM input minimum on-time	Phase Shift PWM mode, Hybrid mode, Current Dimming mode		200	220	ns
$PWM\_IN\_RES$	PWM input resolution	$f_{PWM\_IN} = 100\text{ Hz}$		16		bit
$PWM\_IN\_RES$	PWM input resolution	$f_{PWM\_IN} = 20\text{ kHz}$		10		bit
<b>LED Current Sink and LED PWM Electrical Characteristics</b>						
$I_{LEAKAGE}$	Leakage current on OUTx	$OUTx = V_{OUT} = 45\text{ V}$ , EN= L		0.1	2.5	$\mu\text{A}$
$V_{ISET}$	ISET voltage		1.17	1.21	1.25	V
$I_{MAX}$	Maximum LED sink current	OUTx		200		mA
$V_{ISET\_UVLO}$	ISET pin undervoltage		0.97	1	1.03	V
$R_{ISET}$	ISET Resistor range	$I_{OUT} = 30\text{ mA to }200\text{ mA}$	15.6		104	$\text{k}\Omega$
$I_{LED\_LIMIT}$	LED current limit when ISET pin short to GND			280		mA
$I_{ACC}$	LED sink current accuracy	$R_{ISET} = 15.6\text{ k}\Omega$ , $I_{OUT} = 150\text{ mA}$ , PWM = 100%	-4		4	%
$I_{MATCH}$	LED sink current matching	$R_{ISET} = 15.6\text{ k}\Omega$ , $I_{OUT} = 150\text{ mA}$ , PWM = 100%		1	3.5	%

## 6.5 Electrical Characteristics (continued)

Limits apply over the full operation temperature range  $-40^{\circ}\text{C} \leq T_A \leq +125^{\circ}\text{C}$ , unless otherwise specified.  $V_{IN} = 12\text{ V}$ ,  $V_{DD} = 3.3\text{ V}$

PARAMETER		TEST CONDITIONS	MIN	TYP	MAX	UNIT
$f_{DIM}$	LED dimming frequency	PWM_FSET = 3.92 k $\Omega$	141	152	163	Hz
$f_{DIM}$	LED dimming frequency	PWM_FSET = 4.75 k $\Omega$	283	305	327	
$f_{DIM}$	LED dimming frequency	PWM_FSET = 5.76 k $\Omega$	567	610	653	
$f_{DIM}$	LED dimming frequency	PWM_FSET = 7.87 k $\Omega$	1135	1221	1307	
$f_{DIM}$	LED dimming frequency	PWM_FSET = 11 k $\Omega$	2270	2441	2612	
$f_{DIM}$	LED dimming frequency	PWM_FSET = 17.8 k $\Omega$	4541	4883	5225	
$f_{DIM}$	LED dimming frequency	PWM_FSET = 42.4 k $\Omega$	9082	9766	10450	
$f_{DIM}$	LED dimming frequency	PWM_FSET = 124 k $\Omega$	18163	19531	20899	
DIM	Dimming ratio	$f_{PWM\_OUT} = 152\text{ Hz}$	32000:1			
DIM	Dimming ratio	$f_{PWM\_OUT} = 4.88\text{ kHz}$	1000:1			
$V_{HEADROOM}$	LED sink headroom		0.7			V
$V_{HEADROOM\_HYS}$	LED sink headroom hysteresis		0.8			V
$V_{LED\_SHORT}$	LED internal short threshold		5.4			V
$V_{SHORT\_TO\_GROUND}$	LED short to ground threshold		0.24			V
$t_{PWM\_OUT}$	LED output minimum pulse		200			ns
<b>Boost Converter Electrical Characteristics</b>						
$f_{SW}$	Switching Frequency	BST_FSET = 7.87 k $\Omega$	93	100	107	kHz
$f_{SW}$	Switching Frequency	BST_FSET = 4.75 k $\Omega$	186	200	214	kHz
$f_{SW}$	Switching Frequency	BST_FSET = 5.76 k $\Omega$	281	303	325	kHz
$f_{SW}$	Switching Frequency	BST_FSET = 3.92 k $\Omega$	372	400	428	kHz
$f_{SW}$	Switching Frequency	BST_FSET = 11 k $\Omega$	465	500	535	kHz
$f_{SW}$	Switching Frequency	BST_FSET = 17.8 k $\Omega$	1690	1818	1946	kHz
$f_{SW}$	Switching Frequency	BST_FSET = 42.4 k $\Omega$	1860	2000	2140	kHz
$f_{SW}$	Switching Frequency	BST_FSET = 124 k $\Omega$	2066	2222	2378	kHz
$V_{ISNS}$	External FET current limit	$V_{ISNS}$ threshold, $R_{SENSE} = 15\text{ to }50\text{ m}\Omega$	180	200	220	mV
$I_{SEL\_MAX}$	IDAC maximum current	$V_{DD} = 3.3\text{ V}$	36.4	38.7	40.2	$\mu\text{A}$
$R_{DS\_ONH}$	$R_{DS\_ON}$ of high-side FET to gate driver	$V_{GD}/(R_{DS\_ON} + \text{total resistance to gate input of SW FET})$ must not be higher than 2.5 A	1.4			$\Omega$
$R_{DS\_ONL}$	$R_{DS\_ON}$ of low-side FET to gate driver	$V_{GD}/(R_{DS\_ON} + \text{total resistance to gate input of SW FET})$ must not be higher than 2.5 A	0.75			$\Omega$
$t_{STARUP}$	Start-up time	Delay from beginning of boost Soft-start to when LED drivers can begin	50			ms
$T_{ON}$	Minimum switch on-time		150			ns
$T_{OFF}$	Minimum switch off time		150			ns

(1) This specification is not ensured by ATE.

### 6.6 Logic Interface Characteristics

Limits apply over the full operation temperature range  $-40^{\circ}\text{C} \leq T_A \leq +125^{\circ}\text{C}$ , unless otherwise specified.  $V_{IN} = 12\text{ V}$ ,  $V_{DD} = 5\text{ V}$ ,  $V_{EN} = 3.3\text{ V}$

PARAMETER		TEST CONDITIONS	MIN	TYP	MAX	UNIT
<b>LOGIC INPUT EN</b>						
$V_{EN_{IL}}$	EN logic low threshold				0.4	V
$V_{EN_{IH}}$	EN logic high threshold		1.2			V
$R_{ENPD}$	EN pin internal pull down resistance			1		$M\Omega$
<b>LOGIC INPUT SDA, SCL, BST_SYNC and PWM</b>						
$V_{IL}$	Logic low threshold	$V_{DD} = 3.3\text{ V}$ and $5\text{ V}$			0.4	V
$V_{IH}$	Logic high threshold	$V_{DD} = 3.3\text{ V}$ and $5\text{ V}$	1.2			V
<b>LOGIC OUTPUT SDA, INT</b>						
$V_{OL}$	Output level low	$I = 3\text{ mA}$		0.2	0.4	V
$I_{LEAKAGE}$	Output leakage current	$V = 3.3\text{ V}$			1	$\mu\text{A}$

### 6.7 Timing Requirements for I2C Interface

Limits apply over the full operation temperature range  $-40^{\circ}\text{C} \leq T_A \leq +125^{\circ}\text{C}$ , unless otherwise specified.  $V_{IN} = 12\text{ V}$ ,  $V_{DD} = 5\text{ V}$ ,  $V_{EN} = 3.3\text{ V}$ .

PARAMETER		TEST CONDITIONS	MIN	TYP	MAX	UNIT
$f_{SCLK}$	Clock frequency				400	kHz
1	Hold time (repeated) START condition		0.6			$\mu\text{s}$
2	Clock low time		1.3			$\mu\text{s}$
3	Clock high time		600			ns
4	Set-up time for a repeated START condition		600			ns
5	Data hold time		50			ns
6	Data setup time		100			ns
7	Rise time of SDA and SCL				300	ns
8	Fall time of SDA and SCL				300	ns
9	Set-up time for STOP condition		600			ns
10	Bus free time between a STOP and a START condition		1.3			$\mu\text{s}$



图 6-1. I2C Timing Diagram

### 6.8 Typical Characteristics

Unless otherwise specified:  $C_{IN} = C_{OUT} = 2 \times 10\text{-}\mu\text{F}$  ceramic and  $2 \times 33\text{-}\mu\text{F}$  electrolytic,  $V_{DD} = 3.3\text{ V}$ , charge pump enabled,  $T_A = 25^\circ\text{C}$

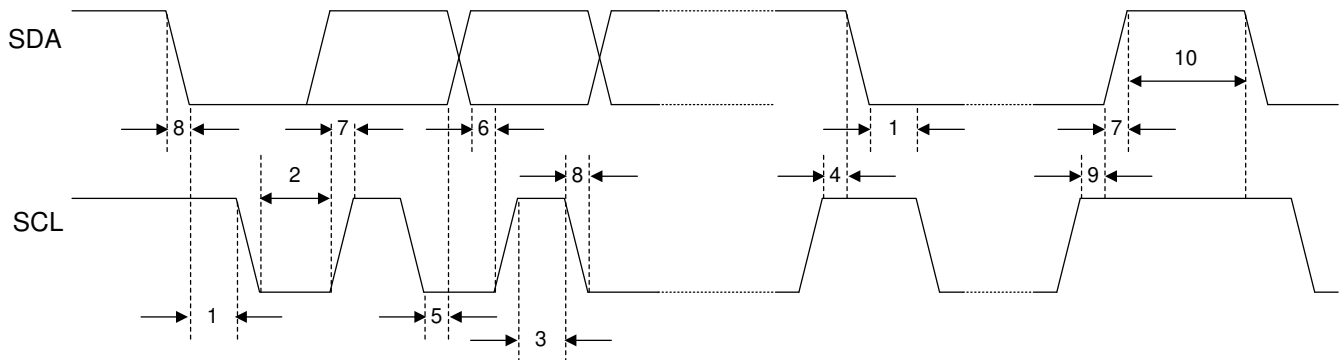
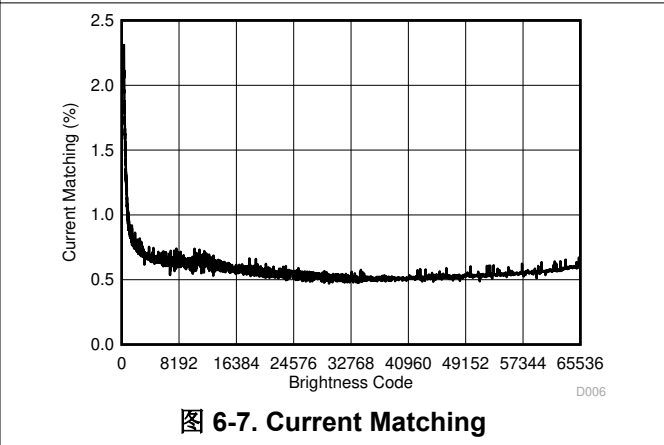
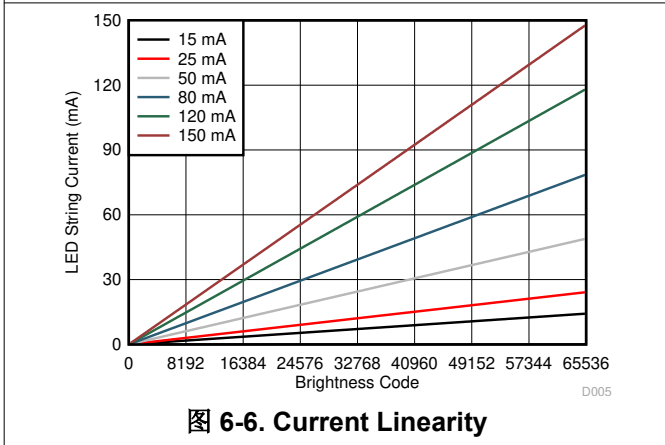
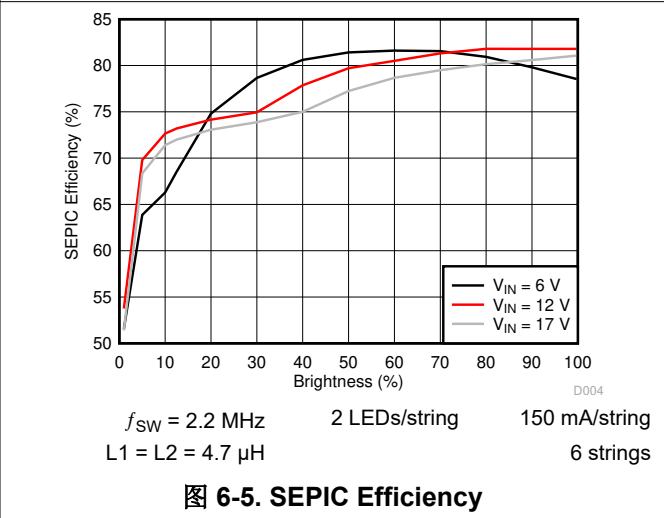
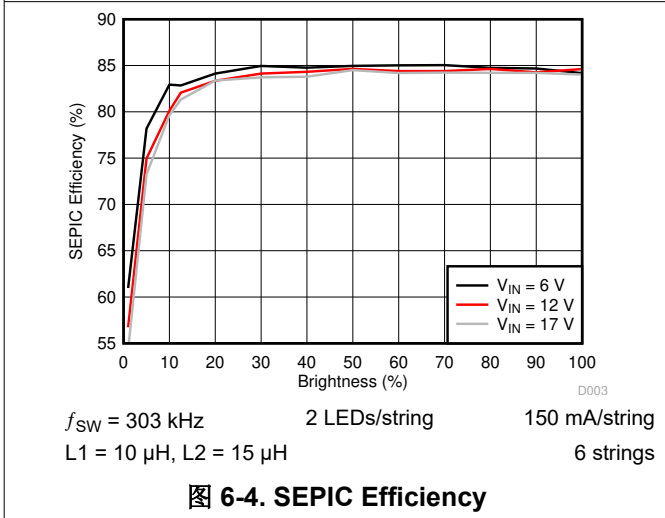
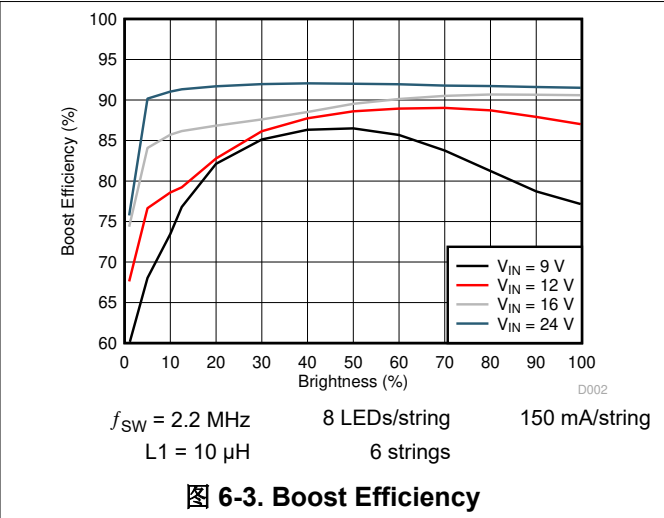
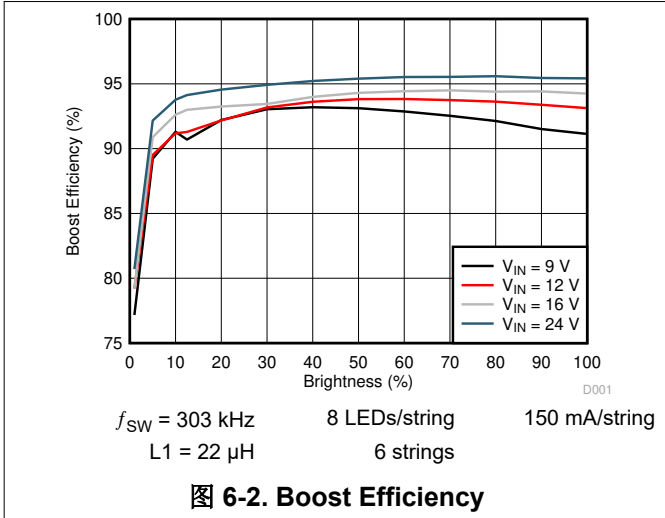

## 7 Detailed Description

### 7.1 Overview

The LP8864S-Q1 device is a high-voltage LED driver for automotive infotainment, clusters, HUD and other automotive display LED backlight applications. PWM input is used for brightness control by default. Alternatively, the brightness can also be controlled by I2C Interface.

The boost frequency, LED PWM frequency, and LED string current are configured with external resistors through the BST\_FSET, PWM\_FSET, and ISET pins. The INT pin is used to report faults to the system. Fault interrupt status can be cleared with the I2C interface, or is cleared on the falling edge of the EN pin.

The LP8864S-Q1 supports pure PWM dimming. The six LED current drivers provide up to 150 mA per output and can be tied together to support higher current LEDs. The maximum output current of the LED drivers is set with the ISET resistor and can be optionally scaled by the LEDx\_CURRENT[11:0] register bits with I2C interface. The LED output PWM frequency is set with a PWM\_FSET resistor. The number of connected LED strings is configured by the LED\_SET resistor, and the device automatically selects the corresponding phase shift mode. For example, if the device is set to 4-strings mode, each LED output is phase shifted by 90 degrees with each other(= 360 / 4). Unused outputs, which must be connected to GND, will be disabled and excluded from adaptive voltage and won't generate any LED faults.

A resistor divider connected from  $V_{OUT}$  to the FB pin sets the maximum voltage of the boost. For best efficiency, the boost voltage is adapted automatically to the minimum necessary level needed to drive the LED strings by monitoring all the LED output voltages continuously. The switching frequency of the boost regulator can be set between 100 kHz and 2.2 MHz by the BST\_FSET resistor. The boost has a start-up feature that reduces the peak current from the power-line during start-up. The LP8864S-Q1 can also control a power-line FET to reduce battery leakage when disabled and provide isolation and protection in the event of a fault.

Fault detection features of LP8864S-Q1 include:

- Open-string and shorted LED detection
  - LED fault detection prevents system overheating in case of open or short in some of the LED strings
- LED short-to-ground detection
- ISET/BST\_FSET/PWM\_FSET/LED\_SET/MODE resistor out-of-range detection
- Boost overcurrent
- Boost overvoltage
- Device undervoltage protection (VDD UVLO)
  - Threshold sensing from VDD pin
- $V_{IN}$  input overvoltage protection ( $V_{IN}$  OVP)
  - Threshold sensing from VSENSE\_P pin
- $V_{IN}$  input undervoltage protection ( $V_{IN}$  UVLO)
  - Threshold sensing from UVLO pin
- $V_{IN}$  input overcurrent protection ( $V_{IN}$  OCP)
  - Threshold sensing across voltage between VSENSE\_P pin and VSENSE\_N pin
- Thermal shutdown in case of die overtemperature

## 7.2 Functional Block Diagram

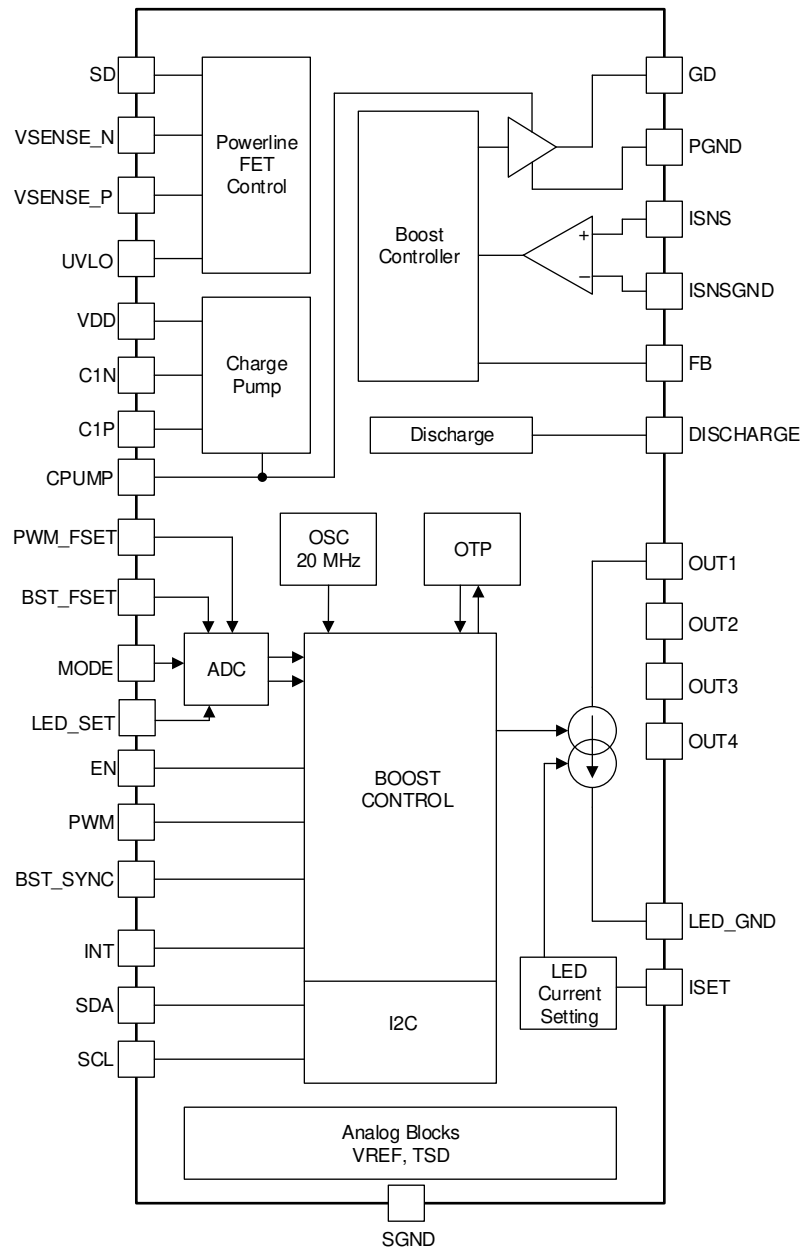

## 7.3 Feature Description

### 7.3.1 Control Interface

Device control interface includes:

- EN is the enable input for the LP8864S-Q1 device.
- PWM is the default input to control the brightness of all current sinks by duty cycle.
- INT is an open-drain fault output indicating fault condition detection.
- SDA and SCL are data and clock line for I2C interface to control the brightness of all current sinks and read back the fault conditions for diagnosis.
- BST\_SYNC is used to input an external clock for the boost switching frequency and control the internal boost clock mode.
  - The external clock is auto detected at start-up and, if missing, the internal clock is used.

- Optionally, the BST\_SYNC can be tied to VDD to enable the boost spread spectrum function or tied to GND to disable it.
- ISET pin to set the maximum LED current level per string.

### 7.3.2 Function Setting

Device parameter setting includes:

- BST\_FSET pin is used to set the boost switching frequency through a resistor to signal ground.
- PWM\_FSET pin is used to set the LED output PWM dimming frequency through a resistor to signal ground.
- MODE pin is used to set the dimming mode via an external resistor to signal ground.
- LED\_SET pin is used to set the LED configuration through a resistor to signal ground.
- ISET pin is used to set the maximum LED current level per OUTx pin.

### 7.3.3 Device Supply (VDD)

All internal analog and digital blocks of LP8864S-Q1 are biased from external supply from VDD pin. Either a typical 5-V or 3.3-V supply rail is able to supply VDD from previous linear regulator or DC/DC converter with at least 150-mA current capability.

### 7.3.4 Enable (EN)

The LP8864S-Q1 only turns on when the input voltage of EN pin is above the voltage threshold ( $V_{EN_{IH}}$ ) and turns off when the voltage of EN pin is below the threshold ( $V_{EN_{IL}}$ ). All analog and digital blocks start operating once the LP8864S-Q1 is enabled by asserting EN pin. The SD pin is floating, I2C interface and Fault detection are not active if the EN pin is de-asserted.

### 7.3.5 Charge Pump

An integrated regulated charge pump can be used to supply the gate drive for the external FET of the boost controller. The charge pump is enabled or disabled by automatically detecting whether VDD and CPUMP pin are connected together. If VDD is  $< 4.5\text{ V}$  then use the charge pump to generate a 5-V gate voltage to drive the external boost switching FET. To use the charge pump, a 2.2- $\mu\text{F}$  capacitor is placed between C1N and C1P. If the charge pump is not required, C1N and C1P could be left unconnected and CPUMP pins tied to VDD. A 4.7- $\mu\text{F}$  CPUMP capacitor is used to store energy for the gate driver. The CPUMP capacitor is required to be used in both charge pump enabled and disabled conditions and must be placed as close as possible to the CPUMP pins. 图 7-1 and 图 7-2 show required connections for both use cases.



图 7-1. Charge Pump Enabled Circuit



图 7-2. Charge Pump Disabled Circuit

If the charge pump is enabled, the CPCAP\_STATUS bit shows whether a fly capacitor was detected and the CP\_STATUS bit shows status of any charge pump faults and generates an INT signal. The CP\_INT\_EN bit can be used to prevent the charge-pump fault from causing an interrupt on the INT pin.

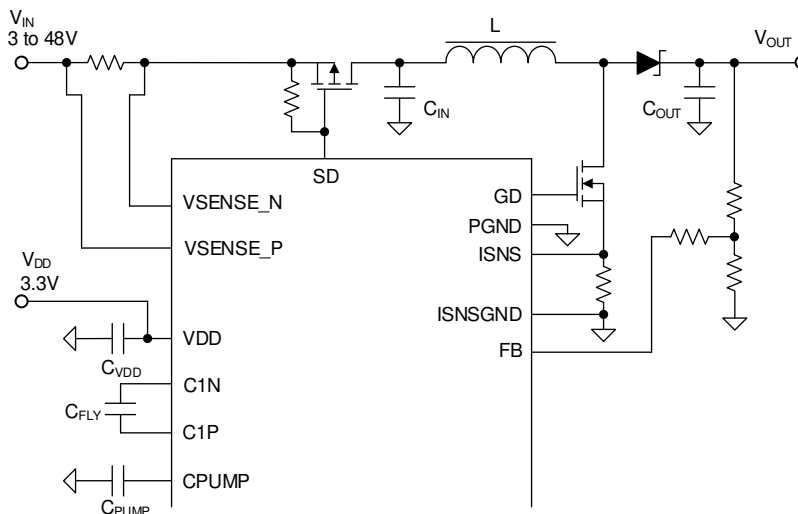
### 7.3.6 Boost Controller

The LP8864S-Q1 current-mode-controlled boost DC/DC controller generates the anode voltage for the LEDs. The boost is a current-mode-controlled topology with a cycle by cycle current limit. The boost converter senses the switch current and across the external sense resistor connected between ISNS and ISNSGND. A 20-m $\Omega$  sense resistor results in a 10-A cycle by cycle current limit. The sense resistor value could vary from 15 m $\Omega$  to 50 m $\Omega$  depending on the application. Maximum boost voltage is configured with external FB-pin resistor divider connected between V<sub>OUT</sub> and FB. The FB-divider equation is described in # 7.3.6.3.

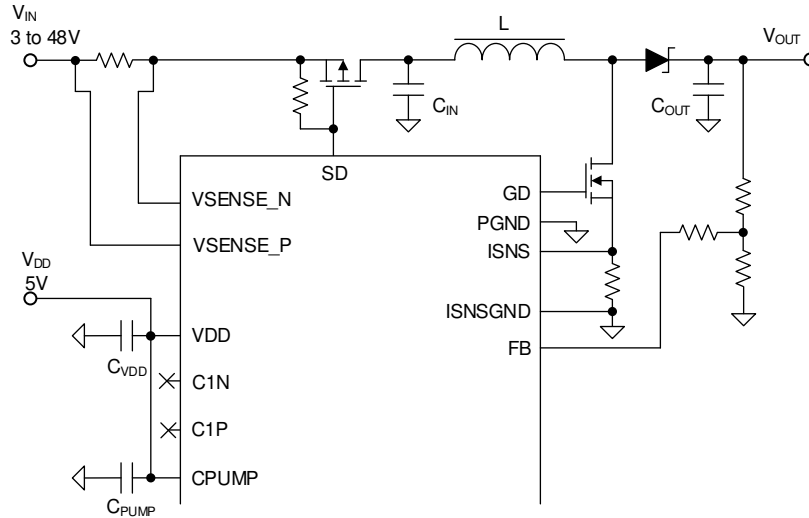

图 7-3. Boost Controller Block Diagram

The boost switching frequency is adjustable from 100 kHz to 2.2 MHz via an external resistor at BST\_FSET (see 表 7-1). Resistor with 1% accuracy is needed to ensure proper operation.

表 7-1. Boost Frequency Selection

R_BST_FSET (kΩ)	BOOST FREQUENCY (kHz)
3.92	400
4.75	200
5.76	303
7.87	100
11	500
17.8	1818
42.2	2000
124	2222

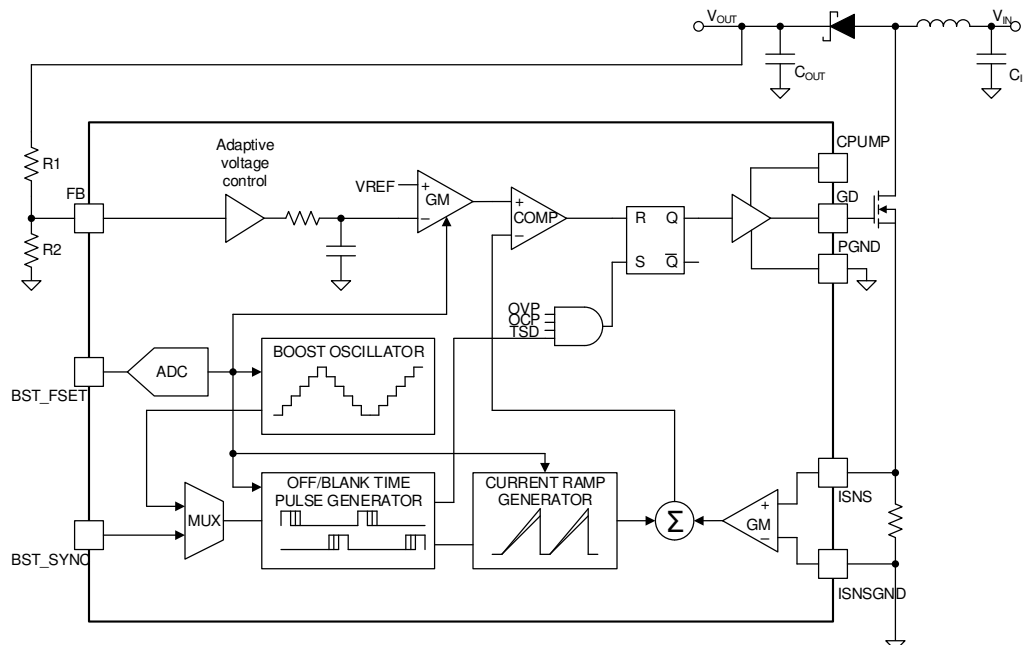
### 7.3.6.1 Boost Cycle-by-Cycle Current Limit

The voltage between ISNS and ISNSGND is used for both boost DC/DC controller's current sensing and cycle-by-cycle current limit settings. When the cycle-by-cycle current limit is reached, the controller will turn off the switching MOSFET immediately and turn on it again in next switching cycle. This cycle-by-cycle current limit could be used as a common protection for all related DC/DC components (inductor, schottky diode and switching MOSFET) to avoid current running over their max limit. Cycle-by-Cycle current limit won't trigger any faults of the device.

$$I_{\text{CYCLE\_LIMIT}} = \frac{V_{\text{ISNS}}}{R_{\text{SENSE}}} \quad (1)$$

where

- $V_{\text{ISNS}} = 200 \text{ mV}$

### 7.3.6.2 Controller Min On/Off Time

The device boost DC/DC controller has minimum on/off time as below table. Minimum off time should be specially taken care in system design. The SW node rising time plus falling time should be higher than minimum off time to avoid controller not turning off the MOSFET.

表 7-2. Controller Minimum On/Off Time

Frequency (kHz)	Minimum Switch OFF Time (ns)	Minimum Switch ON Time (ns)
100 to 500	150	150
1818 to 2222	40	110

### 7.3.6.3 Boost Adaptive Voltage Control

The LP8864S-Q1 boost DC/DC converter generates the anode voltage for the LEDs. During normal operation, boost output voltage is adjusted automatically based on the LED current sink headroom voltages. This is called adaptive boost control. The number of used LED outputs is set by LED\_SET pin and only the active LED outputs are monitored to control the adaptive boost voltage. Any LED strings with open or short faults are also removed from the adaptive voltage control loop. The LED driver pin voltages are periodically monitored by the control loop and the boost voltage is raised if any of the LED outputs falls below the  $V_{\text{HEADROOM}}$  threshold. The boost voltage is lowered until any of the LED outputs touch the  $V_{\text{HEADROOM}}$  threshold. See 图 7-4 for how the boost voltage automatically scales based on the OUTx-pin voltage,  $V_{\text{HEADROOM}}$  and  $V_{\text{HEADROOM\_HYS}}$ .



图 7-4. Adaptive Boost Voltage Control Loop Function

The resistive divider ( $R_1$ ,  $R_2$ ) defines both the minimum and maximum adaptive boost voltage levels. The feedback circuit operates the same in boost and SEPIC topologies. Choose maximum boost voltage based on the maximum LED string voltage specification. Before the LED drivers are active, the boost starts up to the initial boost level. The initial boost voltage is approximately in the 88% point of minimum to maximum boost voltage. Once the LED driver channels are active, the boost output voltage is adjusted automatically based on OUTx pin voltages. The FB pin resistor divider also scales the boost OVP, OCP levels and the LED short level in HUD application.

### 7.3.6.3.1 FB Divider Using Two-Resistor Method

A typical FB-pin circuit uses a two-resistor divider circuit between the boost output voltage and ground.

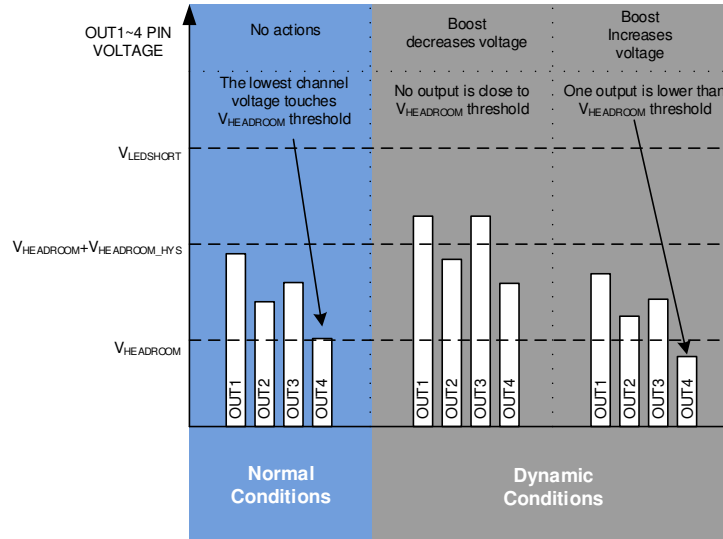

图 7-5. Two-Resistor FB Divider Circuit

Maximum boost voltage can be calculated with [Equation 2](#). The maximum boost voltage can be reached during OPEN string detection or if all LED strings are left disconnected.

$$V_{\text{BOOST\_MAX}} = I_{\text{SEL\_MAX}} \times R_1 + \left( \frac{R_1}{R_2} + 1 \right) \times V_{\text{REF}} \quad (2)$$

where

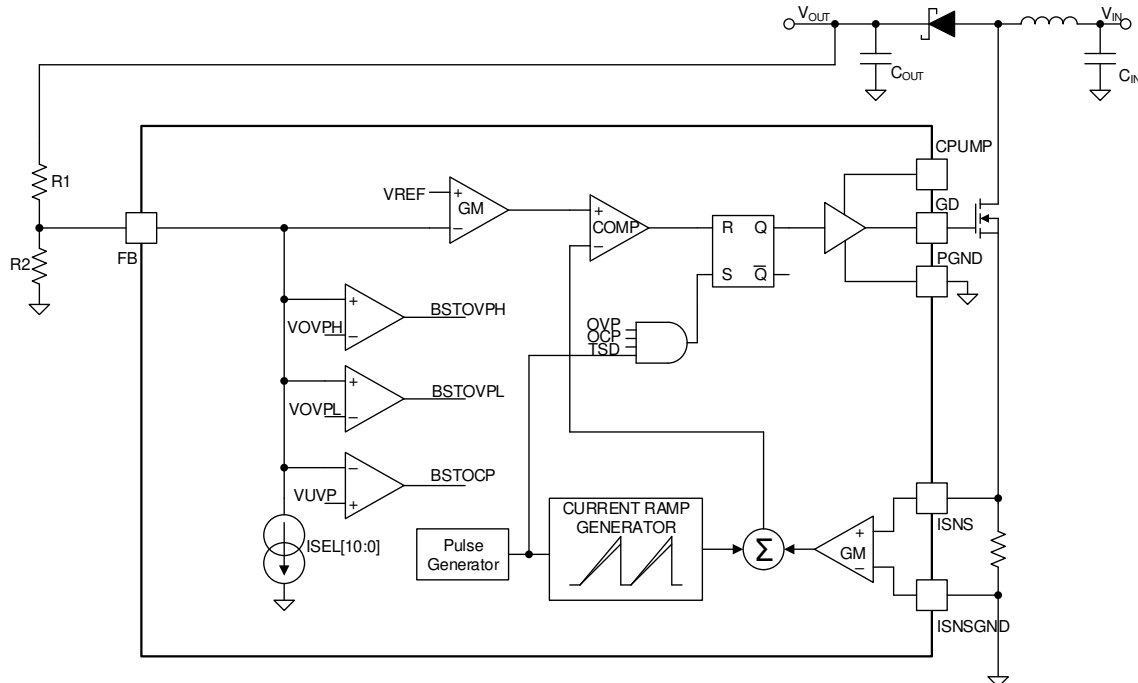
- $V_{\text{REF}} = 1.21 \text{ V}$
- $I_{\text{SEL\_MAX}} = 38.7 \mu\text{A}$
- $R_1 / R_2$  normal recommended range is 7~15

The minimum boost voltage must be less than the minimum LED string voltage. Minimum boost voltage is calculated with [Equation 3](#):

$$V_{\text{BOOST\_MIN}} = \left( \frac{R_1}{R_2} + 1 \right) \times V_{\text{REF}} \quad (3)$$

where

- $V_{\text{REF}} = 1.21 \text{ V}$

When the boost OVP\_LOW level is reached, the boost controller stops switching the boost FET and the BSTOVPL\_STATUS bit is set. The LED drivers are still active during this condition, and the boost resumes normal switching operation once the boost output level falls. The boost OVP low voltage threshold changes dynamically with current boost voltage. It is calculated in [Equation 4](#):

$$V_{\text{BOOST\_OVPL}} = V_{\text{BOOST}} + \left( \frac{R_1}{R_2} + 1 \right) \times (V_{\text{FB\_OVPL}} - V_{\text{REF}}) \quad (4)$$

where

- $V_{\text{FB\_OVPL}} = 1.423 \text{ V}$
- $V_{\text{REF}} = 1.21 \text{ V}$

When the boost OVP\_HIGH level is reached the boost controller enters fault recovery mode, and the BSTOVPH\_STATUS bit is set. The boost OVP high-voltage threshold also changes dynamically with current boost voltage and is calculated in [Equation 5](#):

$$V_{\text{BOOST\_OVPH}} = V_{\text{BOOST}} + \left( \frac{R_1}{R_2} + 1 \right) \times (V_{\text{FB\_OVPH}} - V_{\text{REF}}) \quad (5)$$

where

- $V_{\text{FB\_OVPH}} = 1.76 \text{ V}$
- $V_{\text{REF}} = 1.21 \text{ V}$

When the boost UVP level is reached the boost controller starts a 110-ms OCP counter. The LP8864S-Q1 device enters the fault recovery mode and sets the BSTOCP\_STATUS bit if the boost voltage does not rise above the UVP threshold before the timer expires. The boost UVP voltage threshold also changes dynamically with current boost voltage and is calculated in [Equation 6](#):

$$V_{\text{BOOST\_UVP}} = V_{\text{BOOST}} - \left( \frac{R_1}{R_2} + 1 \right) \times (V_{\text{REF}} - V_{\text{UVP}}) \quad (6)$$

where

- $V_{\text{UVP}} = 0.886 \text{ V}$
- $V_{\text{REF}} = 1.21 \text{ V}$

### 7.3.6.3.2 FB Divider Using Three-Resistor Method

A FB-pin circuit using a three-resistor divider circuit can be used for applications where less than 200-k $\Omega$  resistors are required.



图 7-6. Three-Resistor FB Divider Circuit

Maximum boost voltage can be calculated with Equation 7. The maximum boost voltage can be reached during OPEN string detection or if all LED strings are left disconnected.

$$V_{\text{BOOST\_MAX}} = \left( \frac{R_1 \times R_3}{R_2} + R_1 + R_3 \right) \times I_{\text{SEL\_MAX}} + \left( \frac{R_1}{R_2} + 1 \right) \times V_{\text{REF}} \quad (7)$$

where

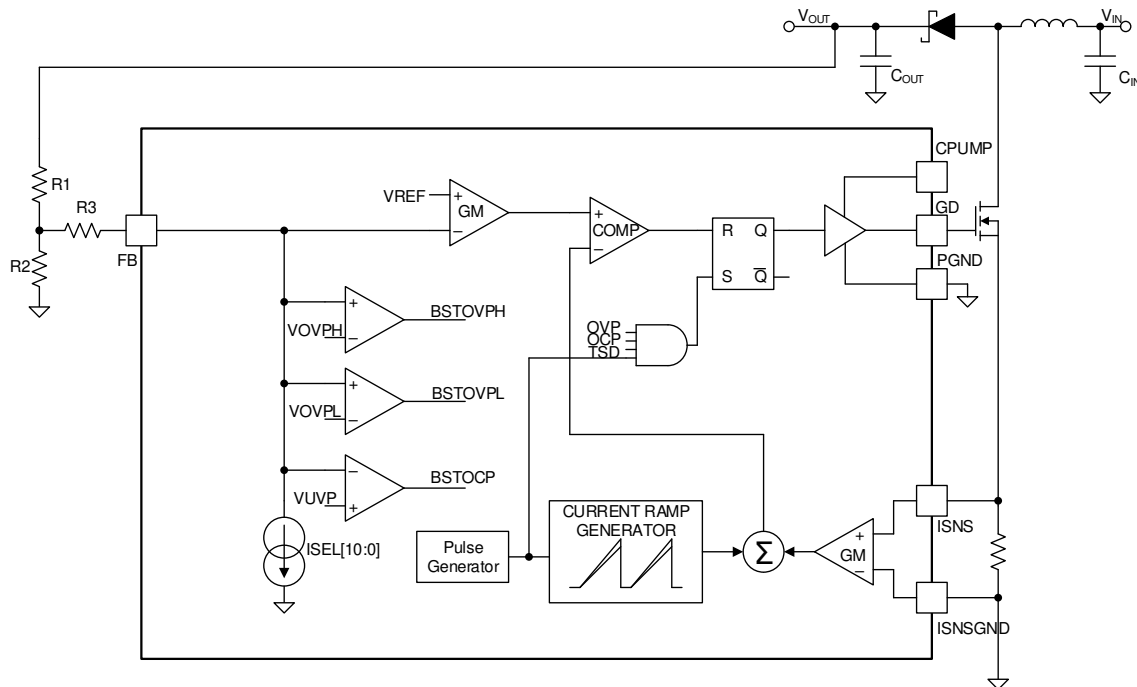
- $V_{\text{REF}} = 1.21 \text{ V}$
- $I_{\text{SEL\_MAX}} = 38.7 \mu\text{A}$
- $R_1 / R_2$  normal recommended range is 7 to 15

The minimum boost voltage must be less than the minimum LED string voltage. Minimum boost voltage is calculated in Equation 8:

$$V_{\text{BOOST\_MIN}} = \left( \frac{R_1}{R_2} + 1 \right) \times V_{\text{REF}} \quad (8)$$

When the boost OVP\_LOW level is reached the boost controller stops switching the boost FET, and the BSTOVPL\_STATUS bit is set. The LED drivers are still active during this condition, and the boost resumes normal switching operation once the boost output level falls. The boost OVP low voltage threshold changes dynamically with current boost voltage. It is calculated in [Equation 9](#):

$$V_{\text{BOOST\_OVPL}} = V_{\text{BOOST}} + \left( \frac{R_1}{R_2} + 1 \right) \times (V_{\text{FB\_OVPL}} - V_{\text{REF}}) \quad (9)$$

where

- $V_{\text{FB\_OVPL}} = 1.423 \text{ V}$
- $V_{\text{REF}} = 1.21 \text{ V}$

When the boost OVP\_LOW level is reached the boost controller enters fault recovery mode, and the BSTOVPH\_STATUS bit is set. The boost OVP high-voltage threshold also changes dynamically with current boost voltage and is calculated in [Equation 10](#):

$$V_{\text{BOOST\_OVPH}} = V_{\text{BOOST}} + \left( \frac{R_1}{R_2} + 1 \right) \times (V_{\text{FB\_OVPH}} - V_{\text{REF}}) \quad (10)$$

where

- $V_{\text{FB\_OVPH}} = 1.76 \text{ V}$
- $V_{\text{REF}} = 1.21 \text{ V}$

When the boost UVP level is reached the boost controller starts a 110-ms OCP counter. The LP8864S-Q1 device enters the fault recovery mode and sets the BSTOCP\_STATUS bit if the boost voltage does not rise above the UVP threshold before the timer expires. The boost UVP voltage threshold also changes dynamically with current boost voltage and is calculated in [Equation 11](#):

$$V_{\text{BOOST\_UVP}} = V_{\text{BOOST}} - \left( \frac{R_1}{R_2} + 1 \right) \times (V_{\text{REF}} - V_{\text{UVP}}) \quad (11)$$

where

- $V_{\text{UVP}} = 0.886 \text{ V}$
- $V_{\text{REF}} = 1.21 \text{ V}$

### 7.3.6.3.3 FB Divider Using External Compensation

The device has internal compensation network to keep the DC-DC control loop in good stability in most cases. However, an additional external compensation network could also be added on FB-pin to offer more flexibility in loop design or solving some extreme use-cases.



图 7-7. External Compensation Network

This network will create one additional pole and one additional zero in the loop.

$$f_{\text{POLE\_COMP}} = \frac{1}{2\pi[(R_1 \parallel R_2) + R_4]C_{\text{COMP}}} \quad (12)$$

$$f_{\text{ZERO\_COMP}} = \frac{1}{2\pi R_4 C_{\text{COMP}}} \quad (13)$$

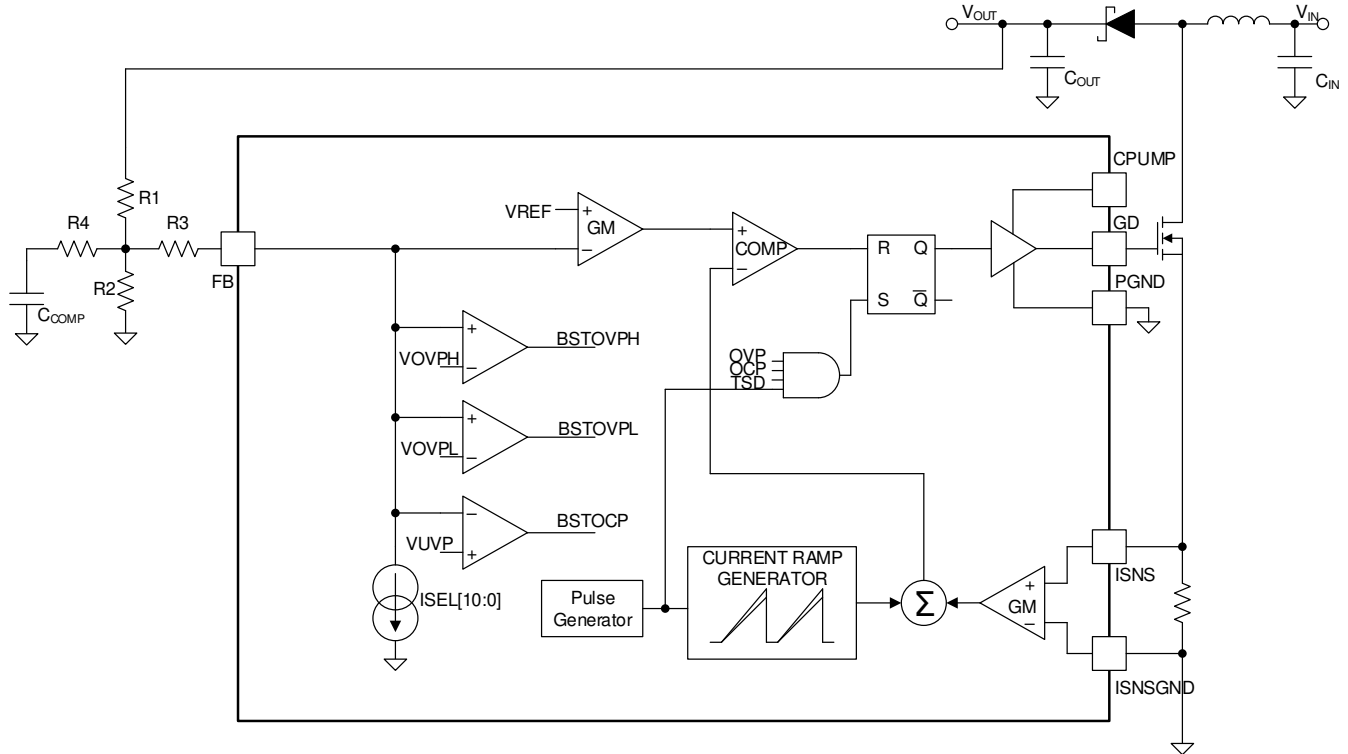
It could be noted that  $R_3$  doesn't take part in the compensation. So this external compensation network could be both used in two-divider network and T-divider network with no equation change.

In real application, for example, when DC-DC loop has stability concern, putting the additional pole in 1 kHz and the additional zero in 2 kHz will suppress the loop gain by approximately 6 dB after 2 kHz. This will benefit gain margin and phase margin a lot.

### 7.3.6.4 Boost Sync and Spread Spectrum

Spread spectrum function could be enabled when BST\_SYNC pin is high and disabled when BST\_SYNC pin is low.

If an external CLK signal is on the BST\_SYNC pin, the boost controller can be clocked by this signal. If the clock disappears later, the boost continues operation at the frequency defined by RBST\_FSET resistor, and the spread spectrum function will be enabled or disabled depending on the final pin level of BST\_SYNC.

表 7-3. Boost Synchronization Mode

BST_SYNC PIN LEVEL	BOOST CLOCK MODE
Low (GND)	Spread spectrum disabled
High (VDDIO)	Spread spectrum enabled

表 7-3. Boost Synchronization Mode (continued)

BST_SYNC PIN LEVEL	BOOST CLOCK MODE
100-kHz to 2222-kHz clock frequency	Spread spectrum disabled, external synchronization mode

If using the external BST\_SYNC input, the  $R_{BST\_SET}$  resistor should be chosen the closest boost frequency options with the external frequency.

The spread spectrum function helps to reduce EMI noise around the switching frequency and its harmonic frequencies. The internal spread spectrum function modulates the boost frequency  $\pm 3.3\%$  to  $7.2\%$  from the central frequency with a 200-Hz to 1.2-kHz modulation frequency. The switching frequency variation is programmable by SPREAD\_RANGE register, and the modulation frequency is programmable by SPREAD\_MOD\_FREQ register. The spread-spectrum function cannot be used when an external synchronization clock is used.

表 7-4. Spread Spectrum Frequency Range

SPREAD_RANGE (Binary)	SWITCHING FREQUENCY VARIATION
00	$\pm 3.3\%$
01	$\pm 4.3\%$
10 (Default)	$\pm 5.3\%$
11	$\pm 7.2\%$

表 7-5. Spread Spectrum Modulation Frequency

SPREAD_MOD_FREQ (Binary)	MODULATION FREQUENCY
00 (Default)	200 Hz
01	500 Hz
10	800 Hz
11	1200 Hz

### 7.3.6.5 Boost Output Discharge

When the EN pin is pulled low, the device stops the boost controller and LED current sinks, turns off the power-line FET, and starts to discharge the boost output. The discharge pin typically sinks 30-mA current. The discharge duration is 400 ms. After 400 ms, the device shuts down. The DISCHARGE pin must be connected with boost output for normal operation.

There is one internal comparator to monitor the voltage of DISCHARGE pin. As soon as the voltage of DISCHARGE pin is higher than  $V_{BST\_OVPH}$  (typically 50 V), the device enters into fault recovery mode, and BST\_OVPH fault is reported. This provides further protection if boost voltage is out of control because of system failure.

Discharge function is only available in HTSSOP package. It's not available in QFN package.

### 7.3.6.6 Light Load Mode

The DC-DC controller will enter into light load mode in below condition:

- $V_{IN}$  voltage is very close to  $V_{OUT}$
- Loading current is very low
- PWM pulse width is very short

When DC-DC converter enters into light load mode, it stops switching occasionally to make sure output voltage won't rise up too much. It could also be called as PFM mode, since the DC-DC converter switching frequency will change in this mode.

### 7.3.7 LED Current Sinks

#### 7.3.7.1 LED Output Current Setting

The maximum output LED current is set by an external resistor value. For the application only using external resistor  $R_{ISET}$  to set the maximum LED current for each string, the Equation 14 is used to calculate the current setting of all strings:

$$I_{LED} = \frac{1.21V}{R_{ISET}} \times 2580 \quad (14)$$

The LEDx\_CURRENT[11:0] registers can also be used to adjust strings current down from this maximum. The default value for LEDx\_CURRENT[11:0] registers is the maximum 0xFFFF(4095). Equation 15 is used to calculate the current setting of an individual string:

$$I_{LED} = \left( \frac{1.21V}{R_{ISET}} \times 2580 \right) \times \left( \frac{LED\_CURRENT[11:0]}{4095} \right) \quad (15)$$

For high accuracy of LED current, the ILED current is recommended to set in range from 30 mA to 200 mA. So the  $R_{ISET}$  value is in the range from 15.6 k $\Omega$  to 104 k $\Omega$ .



图 7-8. LED Driver Current Setting Circuit

#### 7.3.7.2 LED Output String Configuration

The Four LED driver channels of the LP8864S-Q1 device is configured by the LED\_SET resistor, which supports applications using one to Four LED strings. Resistor with 1% accuracy is needed to ensure proper operation. The driver channels can also be tied together in groups of one, two or three. This allows the LP8864S-Q1 device to drive two 300-mA LED strings, or one 600-mA LED string. The LED strings are always appropriately phase shifted for their string configuration. This reduces the ripple seen at the boost output, which allows smaller output capacitors and reduces audible ringing in the capacitors. Phase shift increases the load frequency, which can move potential capacitor noise above the audible band while still keeping PWM frequency low to support a higher dimming ratio.

When the LP8864S-Q1 device is firstly powered on, the string configuration is configured by the LED\_SET resistor and the phases of each channel are automatically configured. The LED string configuration must not be

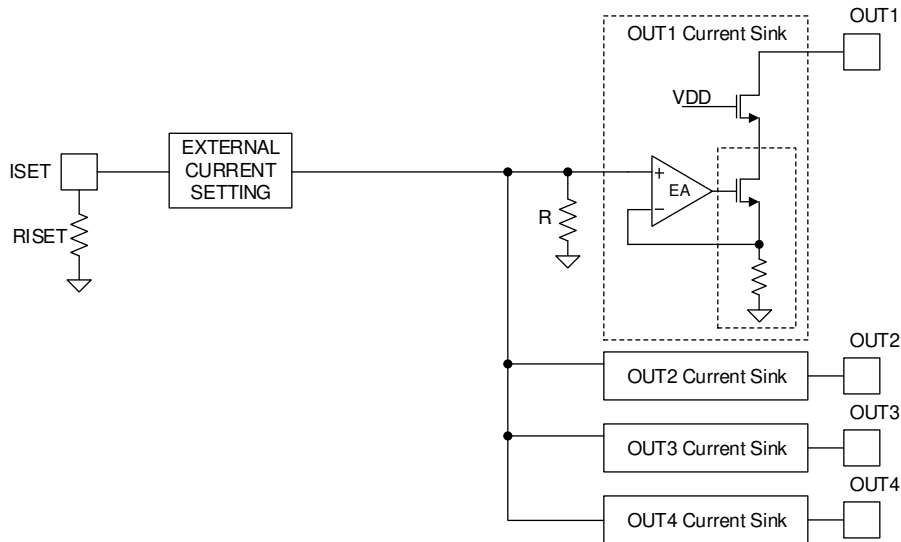
changed unless the LP8864S-Q1 is powered off in shutdown state. The unused LEDx pins should be tied to ground.

表 7-6. LED Output String Configuration

R_LED_SET (kΩ)	CONFIGURATION	OUT1	OUT2	OUT3	OUT4	AUTOMATIC PHASE SHIFT
3.92	4 Channels	150 mA	150 mA	150 mA	150 mA	90°
4.75	3 Channels	150 mA	150 mA	150 mA	(Tied to GND)	120°
5.76	2 Channels	150 mA	150 mA	(Tied to GND)	(Tied to GND)	180°
7.87	2 Channels	300 mA		300 mA		180°
11	1 Channels	600 mA				None

### 7.3.7.3 LED Output PWM Clock Generation

The LED PWM frequency is asynchronous from the input PWM frequency. The LED PWM frequency is generated from the internal 20-MHz oscillator and can be set to eight discrete frequencies from 152 Hz to 19.531 kHz. The PWM\_FSET resistor determines the LED PWM frequency based on 表 7-8. PWM resolution in Table 7-8 is with PWM dither disabled.

### 7.3.8 Brightness Control

The LP8864S-Q1 supports global brightness control for all LED strings through either duty cycle input on PWM pin or register by I2C bus. An internal 20-MHz clock is used for generating PWM outputs.

#### 7.3.8.1 Brightness Control Signal Path

The BRT\_MODE register selects whether the input to the display brightness path is the PWM input pin or DISP\_BRT register. PWM input control will be the default setup after power on. The brightness control signal path diagram is shown in 图 7-9

The display brightness path has sloper function that can be enabled. By default the sloper function is enabled. The sloper and dither function also can be programmable by I2C control. The sloper function is described in 节 7.3.8.7, and the dither function is described in 节 7.3.8.9.



图 7-9. LP8864S-Q1 Brightness Path Diagram

#### 7.3.8.2 Dimming Mode

Dimming mode can be adjusted via an external resistor to MODE pin (see 表 7-7). Resistor with 1% accuracy is needed to ensure proper operation.

表 7-7. Dimming Mode Configuration

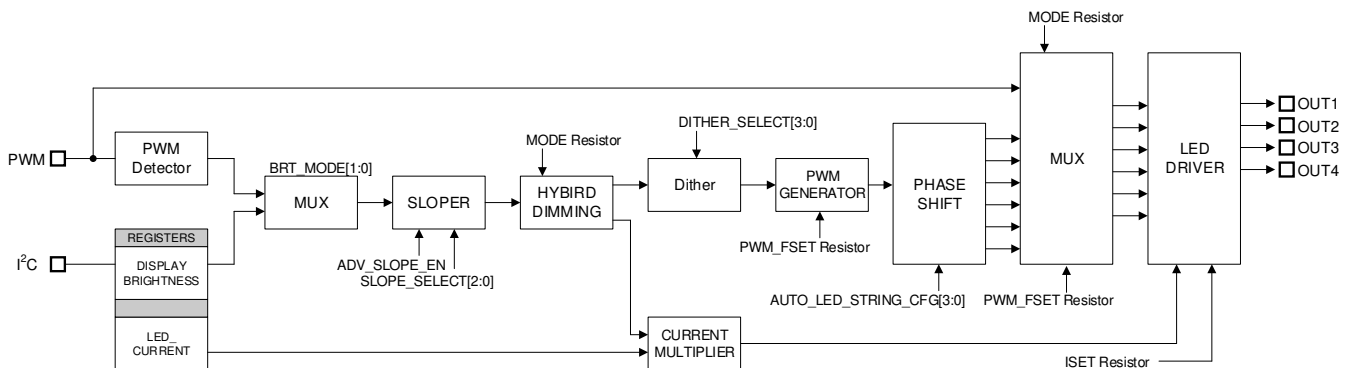
R_MODE (kΩ)	MODE	I2C Address
3.92	Phase-shift PWM Mode	0x3B
4.75	Hybrid Mode	0x3B
5.76	Current Dimming Mode	0x3B

**表 7-7. Dimming Mode Configuration (continued)**

R_MODE (k $\Omega$ )	MODE	I2C Address
7.87	Direct PWM Mode	0x3B
11	Phase-shift PWM Mode	0x3A
17.8	Hybrid Mode	0x3A
42.2	Current Dimming Mode	0x3A
124	Direct PWM Mode	0x3A

### 7.3.8.3 LED Dimming Frequency

The LED dimming frequency is asynchronous from the input PWM frequency for phase-shift PWM mode and hybrid dimming mode. The LED dimming frequency is generated from the internal 20-MHz oscillator and can be set to eight discrete frequencies from 152 Hz to 19.531 kHz. The PWM dimming resolution is highest when the lowest PWM frequency is used. The PWM\_FSET resistor determines the LED Dimming frequency based on [表 7-8](#). Resistor with 1% accuracy is needed to ensure proper operation. PWM resolution in [表 7-8](#) is with PWM dither disabled.

**表 7-8. LED PWM Frequency Selection**

R_PWM_FSET (k $\Omega$ )	LED PWM FREQUENCY (Hz)	PWM DIMMING RESOLUTION (bits)
3.92	152	16
4.75	305	16
5.76	610	15
7.87	1221	14
11	2441	13
17.8	4883	12
42.2	9766	11
124	19531	10

### 7.3.8.4 Phase-Shift PWM Mode

In Phase-Shift PWM mode, all current active channels are turned on and off at LED dimming frequency with a constant delay. However, the number of used channels or channel groups determine the phase delay time between two neighboring channels as shown in [图 7-10](#).



图 7-10. Phase-Shift Dimming Diagram

### 7.3.8.5 Hybrid Mode

In addition to phase-shift PWM dimming, LP8864S-Q1 supports a hybrid-dimming mode. Hybrid dimming combines PWM and current modes for brightness control for the display brightness path. By using hybrid dimming, dimming ratio could be increased by another 8 times. In hybrid mode, PWM dimming is used for low brightness range of brightness, and current dimming is used for high brightness levels as shown in 图 7-11. Current dimming control enables improved optical efficiency due to increased LED efficiency at lower currents. PWM dimming control at low brightness levels ensures linear and accurate control. Hybrid mode can be selected through resistor value at MODE pin as 表 7-7. The PWM and current modes transition threshold can be set at 12.5% or at 0% brightness. The latter selection allows for pure current dimming control mode.

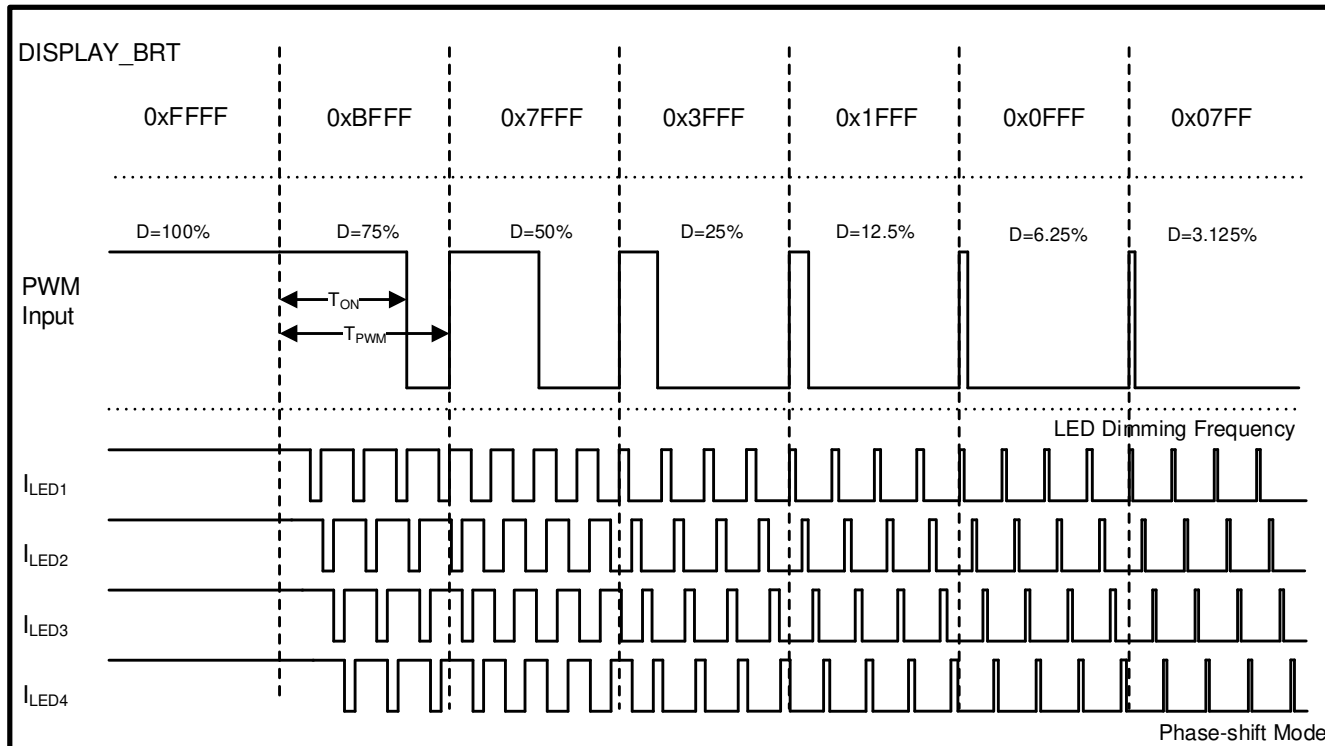

图 7-11. Hybrid Dimming Diagram

### 7.3.8.6 Direct PWM Mode

In direct PWM mode, all active channels are turned on and off and are synchronized with the input PWM signal.

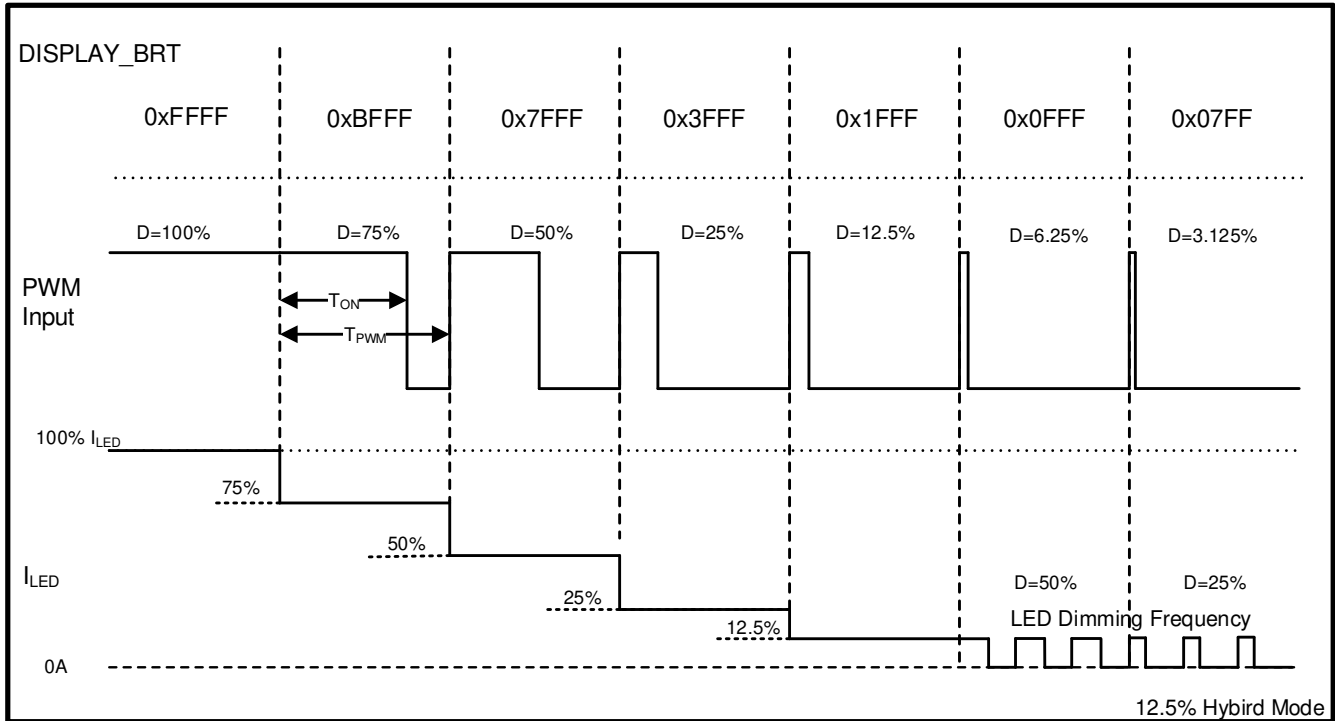

图 7-12. Direct PWM Dimming Diagram

### 7.3.8.7 Sloper

An optional sloper function makes the transition from one brightness value to another optically smooth. By default the advanced sloper is enabled with a 200-ms linear sloper duration. Transition time between two brightness values is programmed with the SLOPE\_SELECT[2:0] bits (when 000, sloper is disabled). With advanced sloper enabled the brightness changes are further smoothed to be more pleasing to the human eye. Advanced slope is enabled with ADV\_SLOPE\_ENABLE register bit.

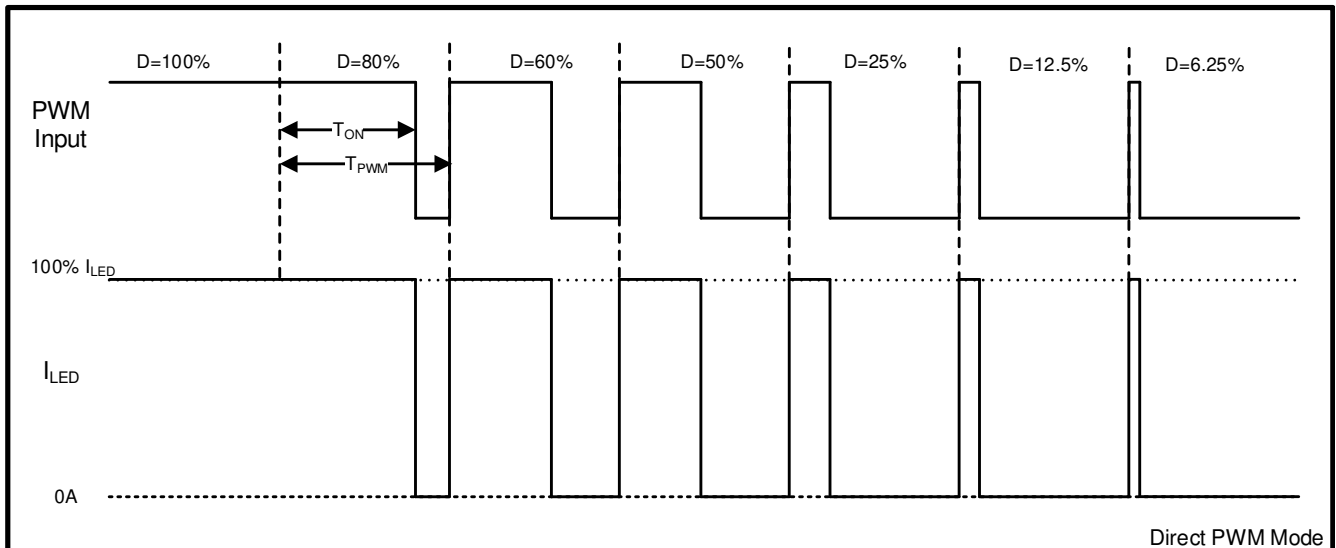

图 7-13. Brightness Sloper

### 7.3.8.8 PWM Detector Hysteresis

PWM detector has an internal hysteresis function. It means when PWM input is used (except direct PWM mode), PWM output duty cycle will change only when PWM input on-time changes by more than 6.4 $\mu$ s. This is to avoid the PWM duty cycle sampling error due to the onboard PWM signal's rising/falling time.

### 7.3.8.9 Dither

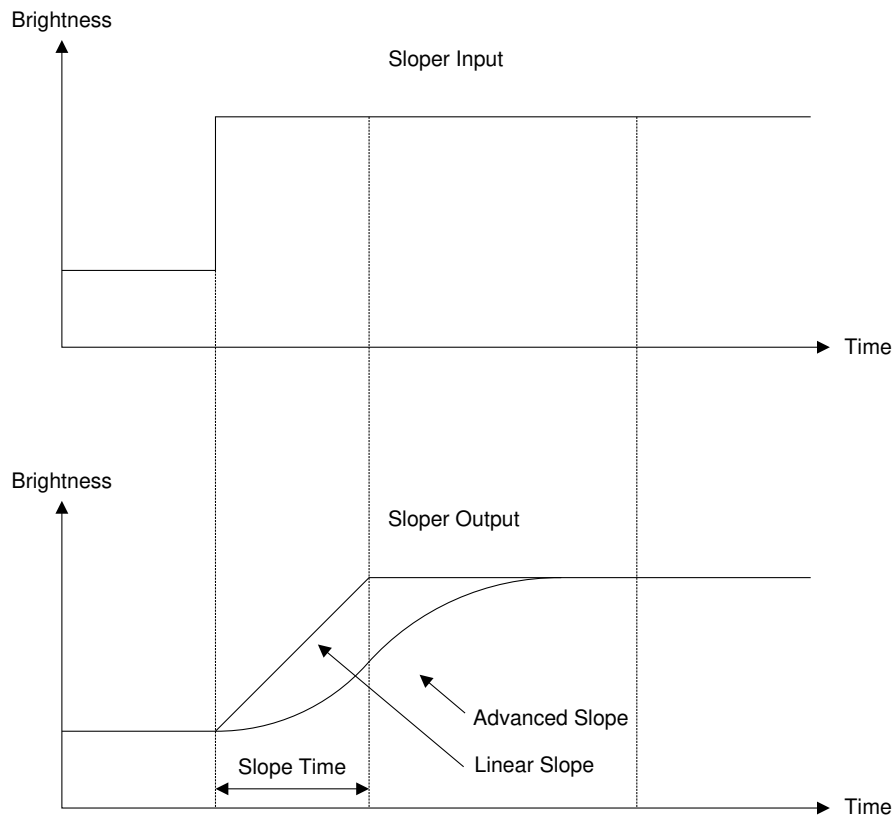
The number of brightness steps when using LED output PWM dimming is equal to the 20-MHz oscillator frequency divided by the LED PWM frequency (set by PWM\_FSET resistor). The PWM duty cycle dither is a function the LP8864S-Q1 uses to increase the number of brightness dimming steps beyond this oscillator clock limitation. The dither function modulates the LED driver output duty cycle over time to create more possible average brightness levels. The DITHER\_SELECT[3:0] register bits control the level of dither, disabled, 1, 2, 3 or 4 bits using the I2C interface. By default the dither is disabled.

When the 1-bit dither is selected, to support higher brightness resolution, the width of every second PWM pulse could be increased by one LSB (one 20-MHz clock period). When the 3-bit dither is selected, within a sequence of 8 PWM periods the number of pulses with increased length varies depending on the dither value: dither value 000 - all 8 pulses at default length; 001 - one of the 8 pulses is longer; 010 - two of the 8 pulses are longer, and so forth, until at 111 - seven of the 8 pulses have increased length. 图 7-14 shows one example of PWM output dither.



图 7-14. PWM Dither Example

The dither block also helps in low brightness scenario when dimming ratio is limited by LED PWM output frequency and the LED output pulse is less than the minimum pulse width (200 ns). In such scenario, the dither block will skip some of the PWM pulses to reduce the brightness further, enabling high dimming ratio. The end result is that the LED PWM frequency is reduced as more and more minimum pulses are skipped or dithered out. At the same time, dither block will also guarantee that the minimum LED PWM frequency is not less than 152 Hz to ensure no brightness flickering. 图 7-15 shows how the dither works in low brightness scenario.

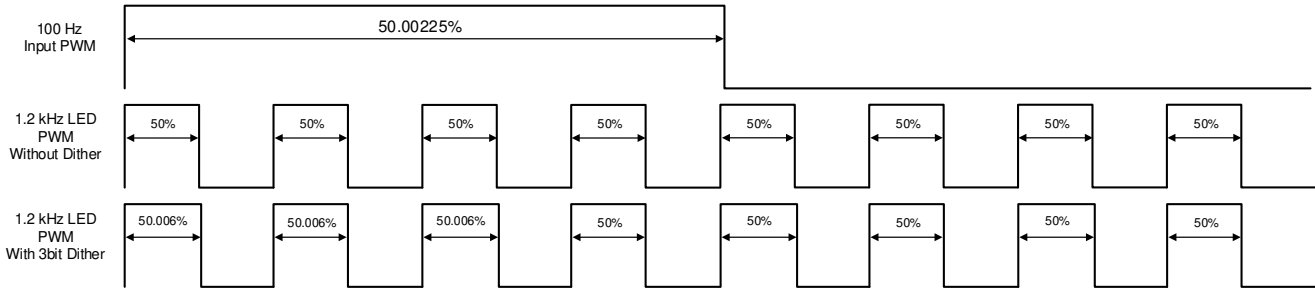

图 7-15. Minimum Brightness Dither Example

### 7.3.9 Protection and Fault Detections

The LP8864S-Q1 device includes fault detections for LED open, short and short-to-GND conditions, boost input undervoltage, overvoltage and overcurrent, boost output overvoltage and overcurrent, VDD undervoltage, die overtemperature and external components. The host can monitor the status of the faults in registers SUPPLY\_FAULT\_STATUS, BOOST\_FAULT\_STATUS and LED\_STATUS.

#### 7.3.9.1 Supply Faults

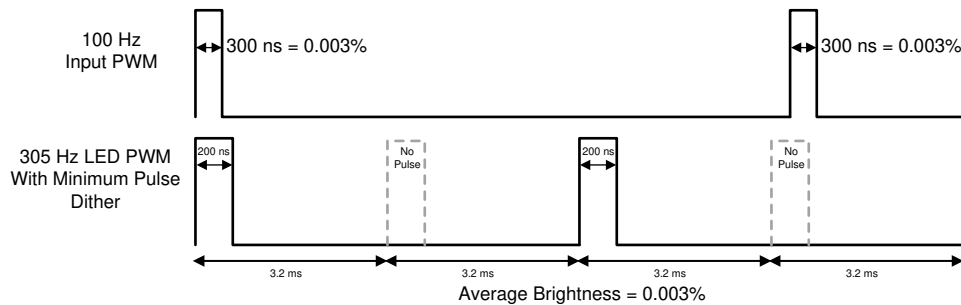
##### 7.3.9.1.1 $V_{IN}$ Undervoltage Faults (VINUVLO)

The LP8864S-Q1 device supports  $V_{IN}$  undervoltage and overvoltage protection. The undervoltage threshold is programmable through external resistor divider on UVLO pin. If during operation of the LP8864S-Q1 device, the UVLO pin voltage falls below the UVLO falling level (0.787 V typical), the boost, LED outputs, and power-line FET will be turned off, and the device will enter STANDBY mode. The VINUVLO\_STATUS bit is also set in the SUPPLY\_FAULT\_STATUS register, and the INT pin is triggered. When the UVLO voltage rises above the rising threshold level the LP8864S-Q1 exits STANDBY and begins the start-up sequence.



图 7-16.  $V_{IN}$  UVLO Setting Circuit

The following equation is used to calculate the UVLO threshold for  $V_{IN}$  rising edge:

$$V_{IN_{UVLO\_RISING}} = \left( \frac{R_4}{R_5} + 1 \right) \times V_{IN_{UVLO\_TH}} \quad (16)$$

where

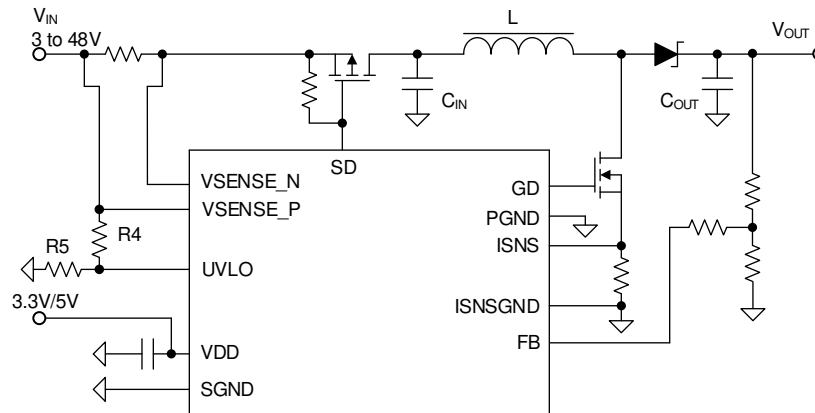
- $V_{IN_{UVLO\_TH}} = 0.787 \text{ V}$

The hysteresis of UVLO threshold can be designed and calculated with the following equation.

$$V_{IN_{HYST}} = R_4 \times I_{UVLO} \quad (17)$$

where

- $I_{UVLO} = 5 \mu\text{A}$

So the following equation can be used for UVLO threshold for  $V_{IN}$  falling edge:

$$V_{IN_{UVLO\_FALLING}} = V_{IN_{UVLO\_RISING}} - V_{IN_{HYST}} \quad (18)$$

The bottom resistor,  $R_5$  of voltage divider is able to be disconnected to the GND through an additional external N-type of FET as 图 7-17. This design is to minimize the current leakage from  $V_{IN}$  in shutdown mode to extend the battery life.



图 7-17.  $V_{IN}$  UVLO Setting Circuit Without Current Leakage Path

### 7.3.9.1.2 $V_{IN}$ Overvoltage Faults (VINOVP)

The overvoltage threshold for  $V_{IN}$  rising edge is internal fixed at typical 43 V. If during LP8864S-Q1 operation, VSENSE\_P pin voltage rises above the OVP rising threshold, boost, LED outputs, and power-line FET will be turned off, and the device will enter STANDBY mode. The VINOVP\_STATUS bit will also be set in the SUPPLY\_FAULT\_STATUS register, and the INT pin will be triggered. When the VSENSE\_P pin voltage falls below the falling threshold level, the LP8864S-Q1 exits STANDBY and begins the start-up sequence.

### 7.3.9.1.3 $V_{DD}$ Undervoltage Faults (VDDUVLO)

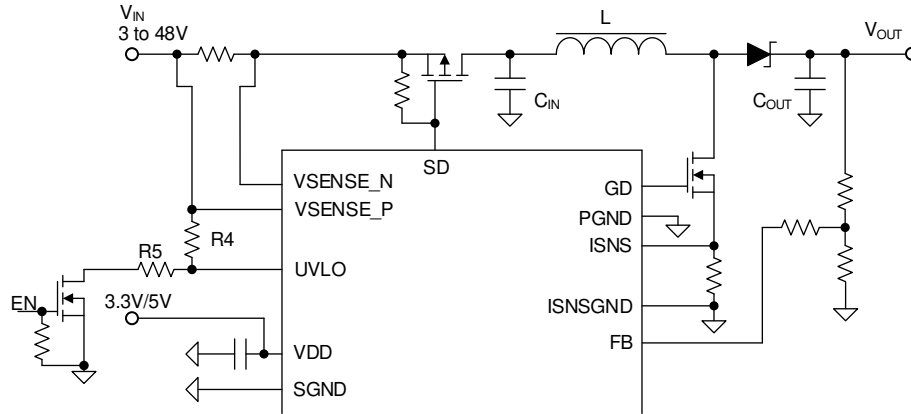
If during LP8864S-Q1 device operation VDD falls below VDDUVLO falling level, boost, power-line FET, and LED outputs are turned off, and the device enters STANDBY mode. The VDDUVLO\_STATUS fault bit will be set in the SUPPLY\_FAULT\_STATUS register, and the INT pin will be triggered. The LP8864S-Q1 restarts automatically to ACTIVE mode when  $V_{DD}$  rises above VDDUVLO rising threshold.

### 7.3.9.1.4 $V_{IN}$ OCP Faults (VINOCP)

If during LP8864S-Q1 device operation voltage drop on RISENSE resistor rises above 220 mV, boost, power-line FET, and LED outputs are turned off, and the device enters Fault Recovery mode and then attempt to restart 100 ms after fault occurs. The VINOCP\_STATUS fault bit are set in the SUPPLY\_FAULT\_STATUS register, and the INT pin is triggered.

$$I_{VIN\_OCP} = \frac{VIN_{OCP\_TH}}{R_{ISENSE}} \quad (19)$$

where

- $VIN_{OCP\_TH} = 220$  mV

#### 7.3.9.1.4.1 $VIN$ OCP Current Limit vs. Boost Cycle-by-Cycle Current Limit

$VIN$  OCP current limit is totally different from boost cycle-by-cycle current limit.

Boost cycle-by-cycle current limit is to protect the DC/DC components (inductor, schottky diode and switching MOSFET) in normal scenario, avoiding current running over their max limit. The normal scenario means when loading has sharp change or input voltage has sharp change. It won't trigger any device fault.

$VIN$  OCP current limit is to protect system from critical system hazard (e.g, inductor short, switching MOSFET short). It will trigger the device to shutdown all the LED channels and enter into fault recovery state.

$VIN$  OCP current limit should be always greater than boost cycle-by-cycle current limit. This means  $R_{ISENSE}$  should be always no smaller than  $R_{SENSE}$ .

### 7.3.9.1.5 Charge Pump Faults (CPCAP, CP)

If during LP8864S-Q1 device operation voltage of CPUMP pin falls below typical 4.2-V, boost, power-line FET, and LED outputs are turned off, and the device enters Fault Recovery mode and then attempt to restart 100 ms after fault occurs. The CP\_STATUS fault bit will be set in the SUPPLY\_FAULT\_STATUS register, and the INT pin are triggered.

If during LP8864S-Q1 device initialization, the charge pump fly capacitor is disconnected or shorted, charge pump are turned off. In result, boost, power-line FET, and LED outputs are turned off, and the device enters Fault Recovery mode and then attempt to restart 100 ms after fault occurs. Both CPCAP\_STATUS and CP\_STATUS fault bits are set in the SUPPLY\_FAULT\_STATUS register, and the INT pin are triggered.

### 7.3.9.1.6 CRC Error Faults (CRCERR)

If during LP8864S-Q1 device initialization, the factory default configuration for registers, options and trim bits are not corrected loaded from memory, LP8864S-Q1 keeps operating normally, unless other fault criteria is triggered. The CRCERR\_STATUS fault bit are set in the SUPPLY\_FAULT\_STATUS register and the INT pin are triggered.

## 7.3.9.2 Boost Faults

### 7.3.9.2.1 Boost Overvoltage Faults (BSTOVPL, BSTOVPH)

Boost overvoltage is detected if the FB pin voltage exceeds the  $V_{FB\_OVPL}$  threshold. When boost overvoltage is detected, BSTOVPL\_STATUS bit will be set in the BOOST\_FAULT\_STATUS register. The boost FET stops switching, and the output voltage will be automatically limited. If the BSTOVPL\_STATUS bit is continually set (that is, reappears after clearing), it may indicate an loop issue in the application. Boost overvoltage low is monitored during device Boost Softstart and Normal mode.

A second boost overvoltage high fault is detected if the FB pin voltage exceeds the  $V_{FB\_OVPH}$  threshold or the DISCHARGE pin voltage exceeds the  $V_{BST\_OVPH}$ . The LP8864S-Q1 device enters the fault recovery state to protect system damage from a high boost voltage. When boost overvoltage is detected, BSTOVPH\_STATUS bit is set in the BOOST\_FAULT\_STATUS register. A fault interrupt is also generated. The device enters Fault Recovery mode and then attempt to restart after 100 ms. Boost overvoltage high is monitored during Boost Softstart and Normal mode.

### 7.3.9.2.2 Boost Overcurrent Faults (BSTOCP)

Boost overcurrent is detected if the FB pin voltage drops below the  $V_{UVP}$  threshold for 110 ms. If the boost overcurrent timer expires before the output voltage recovers, the BSTOCP\_STATUS bit is set in the BOOST\_FAULT\_STATUS register. The fault recovery state is entered, and a fault interrupt is generated. The device will enter Fault Recovery mode and then attempt to restart after 100 ms. If the BSTOCP\_STATUS bit is permanently set, it may indicate an issue in the application. Boost overcurrent is monitored from the boost start, and fault may trigger during boost start-up.

### 7.3.9.2.3 LEDSET Resistor Missing Faults (LEDSET)

The LEDSET resistor missing or invalid is detected if the resistor is not assembled or not valid value as requested during the initialization. The LP8864S-Q1 device defaults to 4-channel/150-mA configuration if the LEDSET resistor is missing or invalid. The LEDSET\_STATUS fault bit is set in the BOOST\_FAULT\_STATUS register. The LEDSET resistor missing or invalid fault will not be monitored after initialization, so that the LP8864S-Q1 is operating in the configuration determined during initialization even though the LEDSET resistor is missing or invalid after initialization.

### 7.3.9.2.4 MODE Resistor Missing Faults (MODESEL)

The MODE resistor missing or invalid is detected if the resistor is not assembled or not valid value as requested during the initialization. LP8864S-Q1 defaults to phase-shift PWM mode with I2C address 0x3A if the MODE resistor is missing or invalid. The MODESEL\_STATUS fault bit will be set in the BOOST\_FAULT\_STATUS register. The MODE resistor missing or invalid fault is not monitored after initialization, so that the LP8864S-Q1 operates in the mode determined during initialization even though the MODE resistor is missing or invalid after initialization.

### 7.3.9.2.5 FSET Resistor Missing Faults (FSET)

The FSET resistor missing or invalid for both BOOST\_FSET and PWM\_FSET is detected if any one of them is not assembled or not a valid value as requested during the initialization. LP8864S-Q1 defaults the switching frequency of boost to 400 kHz if BOOST\_FSET resistor is missing or invalid, or PWM dimming frequency to 305 Hz if PWM\_FSET resistor is missing or invalid. The FSET\_STATUS fault bit is set in the BOOST\_FAULT\_STATUS register. The FSET resistor missing or invalid fault is not monitored after initialization, so that the LP8864S-Q1 device operates at the boost switching frequency and the PWM dimming frequency determined during initialization even though the FSET resistor is missing or invalid after initialization.

### 7.3.9.2.6 ISET Resistor Out of Range Faults (ISET)

If the ISET pin resistor is shorted to GND during normal operation, the maximum current for each LED channel can be calculated in [Equation 20](#):

$$I_{LED\_ISET\_FAULT} = I_{LED\_LIMIT} \times \left( \frac{LED\_CURRENT[11:0]}{4095} \right) \quad (20)$$

where

- $I_{LED\_LIMIT} = 280 \text{ mA}$

LED\_CURRENT[11:0] register will be automatically modified to 1/4 of latest programmed data. If it is not programmed after device enabling, the default value of LED\_CURRENT[11:0] register is 0xFFF and automatically modified to 0x3FF after the fault occurs. If ISET pin voltage returns back to above 1.1 V, the LED\_CURRENT[11:0] register data automatically returns to latest programmed data. The ISET\_STATUS fault bit will be set in the BOOST\_FAULT\_STATUS register and the INT pin is triggered.

### 7.3.9.2.7 Thermal Shutdown Faults (TSD)

If the die temperature of LP8864S-Q1 reaches the thermal shutdown threshold  $T_{SD}$ , the boost, power-line FET, and LED outputs on LP8864S-Q1 shuts down to protect the device from damage. Fault status bit TSD\_STATUS bit will be set, and the INT pin will be triggered. The device restarts the power-line FET, the boost, and LED outputs when temperature drops by TSD\_HYS amount.

## 7.3.9.3 LED Faults

### 7.3.9.3.1 Open LED Faults (OPEN\_LED)

During normal boost operation, boost voltage is raised if any of the used LED outputs falls below the LED\_DRV\_HEADROOM threshold level. Open LED fault is detected if boost output voltage has reached the maximum and at least one LED output is still below the threshold. The open string is then disconnected from the boost adaptive control loop and its output is disabled. Any LED fault sets the status bit LED\_STATUS and an interrupt is generated unless LED interrupt is disabled. The detail of open LED faults can be read from bits OPEN\_LED and LEDx\_FAULT ( $x = 1 \dots 4$ ). These bits maintain their value until device power-down. But the LED\_STATUS bit could be cleared by the interrupt clearing procedure. If a new LED fault is detected, LED\_STATUS is set and an interrupt generated again.



图 7-18. LED Open and Short Detection Logic

#### 7.3.9.3.2 Short LED Faults (SHORT\_LED)

Short LED fault is detected if one or more LED outputs are above the  $V_{LEDSHORT}$  typical 5.4 V and at least one LED output is inside the normal operation window (see 图 7-18). Shorted string is disconnected from the boost adaptive control loop and the LED PWM output is disabled. LED\_STATUS status bit is set and an interrupt generated similarly as in open LED case. Detailed shorted LED fault can be read from bits SHORT\_LED and LED<sub>x</sub>\_FAULT ( $x = 1..4$ ), indicating the faulty LED) in LED\_FAULT\_STATUS register.

In HUD application, when output channels are connected as groups and only one or two groups are active, one more special condition will trigger the short LED fault. This is when boost adaptive voltage comes to minimum and one of the LED channels voltage is still higher than  $V_{HEADROOM} + V_{HEADROOM\_HYS}$ .

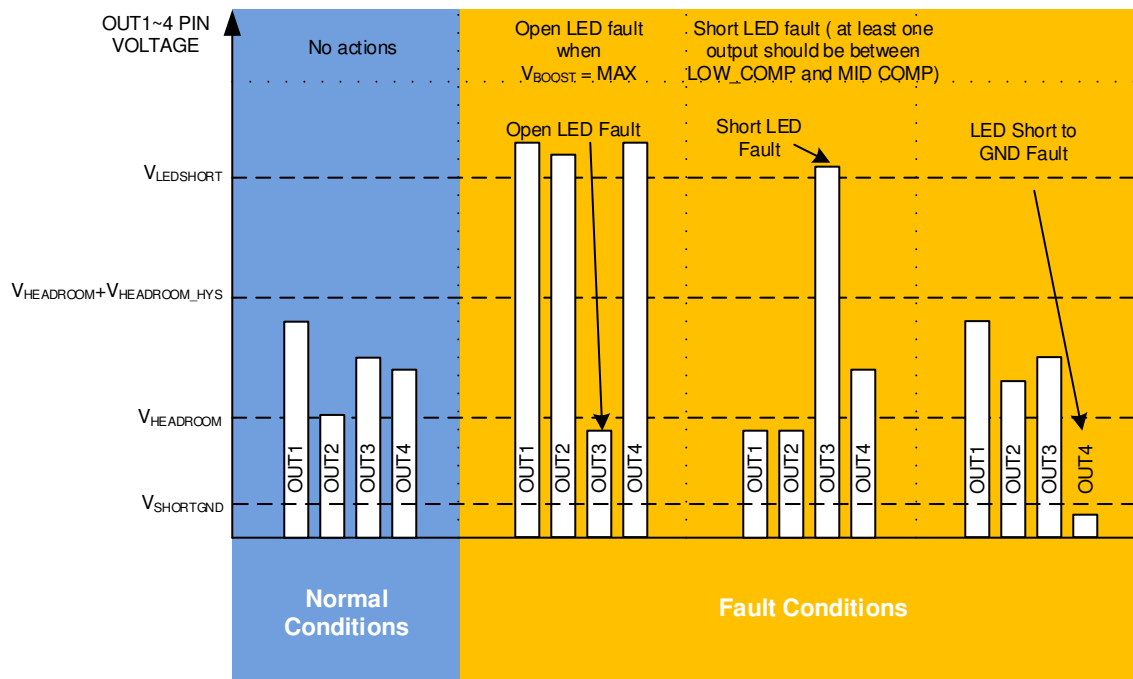
#### 7.3.9.3.3 LED Short to GND Faults (GND\_LED)

During boost soft start and normal boost operation, if LED output is lower than  $V_{SHORTGND}$  for 20 ms, device turns off the corresponding LED output channel and output a typical 6-mA current for 300- $\mu$ s period again. After this operation, if output voltage is still lower than  $V_{HEADROOM}$ , LED short to GND fault will be reported.

If LED short to GND is reported, boost, LED outputs and power-line FET is turned off, the device will enter Fault Recovery mode. LED\_STATUS bit is set and an interrupt generated similarly as in open LED case. LED short to GND fault reason can be read from bits LED\_GND and LED<sub>x</sub>\_FAULT ( $x = 1..4$ ) in LED\_FAULT\_STATUS register. These bits maintain their value until device powers are down while the LED\_STATUS bit is cleared by the interrupt clearing procedure.

#### 7.3.9.3.4 Invalid LED String Faults (INVSTRING)

During device initialization, any of un-used LED outputs pins are checked whether connected to GND or not. If they are not connected to GND as expected, the LP8864S-Q1 reports invalid string fault and tries to function normally if possible. The INVSTRING\_STATUS fault bit is set in the LED\_FAULT\_STATUS register, and the INT pin is triggered. The LEDSET resistor missing or invalid fault is not detected after initialization, so that the LP8864S-Q1 operates in the configuration determined during initialization even though the LEDSET resistor is missing or invalid after initialization.

#### **7.3.9.3.5 I2C Timeout Faults**

If chip receives I2C command without STOP signal for 500 ms, I2C communication block auto resets and waits for the next command. I2C\_ERROR\_STATUS fault bit is set in the LED\_FAULT\_STATUS register, and the INT pin is triggered.

### 7.3.9.4 Overview of the Fault and Protection Schemes

表 7-9. Fault and Protection Schemes

FAULT NAME	STATUS BIT	CONDITION	TRIGGER FAULT INTERRUPT	ENTER FAULT RECOVERY	ACTION
V <sub>IN</sub> undervoltage	VINUVLO_STATUS	UVLO voltage falls below 0.787 V.	Yes	Yes	Device goes to standby and then attempts to restart once the input voltage rises above threshold.
V <sub>IN</sub> overvoltage	VINOVP_STATUS	V <sub>IN</sub> voltage rises above 43 V.	Yes	Yes	Device goes to standby and waits until input voltage falls below threshold before restarting.
V <sub>DD</sub> undervoltage	VDDUVLO_STATUS	V <sub>DD</sub> level falls below VDDUVLO threshold.	Yes	No	Device restarts once VDD level rises above VDDUVLO threshold.
V <sub>IN</sub> overcurrent	VINOCP_STATUS	Voltage across R <sub>ISENSE</sub> exceeds 220 mV.	Yes	Yes	Device goes to Fault Recovery and then attempts to restart 100 ms after fault occurs.
Charge pump fault	CP_STATUS	Charge pump voltage level is abnormal.	Yes	Yes	Device goes to Fault Recovery and then attempts to restart 100 ms after fault occurs.
Charge pump components missing	CPCAP_STATUS	Charge pump is missing components.	Yes	No	Charge pump is disabled. Charge pump fault will be reported. Device tries to keep normal operation.
Boost sync clock invalid fault	BSTSYNC_STATUS	Device is enabled while a valid external SYNC clock is running. Then SYNC stops or changes to frequency < 75 kHz.	Yes	No	Defaults to internal clock frequency selected by BST_FSET resistor. If BST_SYNC input is held high then spread spectrum is enabled. If BST_SYNC input is held low then spread spectrum is disabled.
CRC error	CRCERR_STATUS	Factory default configuration for registers, options and trim bits are not correctly loaded from memory.	Yes	No	Device functions normally, if possible.
Boost OVP low	BSTOVFLOW_STATUS	FB pin voltage rises above V <sub>FB_OVPL</sub> level.	No	No	Boost stops switching until boost voltage level falls. The device remains in normal mode with LED drivers operational.
Boost OVP high	BSTOVPH_STATUS	FB pin voltage rises above V <sub>FB_OVPH</sub> level or DISCHARGE pin voltage rises above V <sub>BST_OVPH</sub> .	Yes	Yes	Device goes to Fault Recovery and waits until output voltage falls below threshold before restarting.
Boost overcurrent	BSTOCP_STATUS	FB pin voltages falls below V <sub>UVF</sub> level for 110 ms.	Yes	Yes	Device goes to Fault Recovery and then attempts to start 100 ms after fault occurs.
LEDSET detection fault	LEDSET_STATUS	LEDSET resistor missing or invalid.	No	No	Defaults to 4-channel / 150-mA configuration.
MODE detection fault	MODESEL_STATUS	MODE resistor missing or invalid.	No	No	Defaults to phase-shift PWM mode, I2C address is 0x3A.
FSET detection fault	FSET_STATUS	BST_FSET or PWM_FSET resistor are missing or an invalid value.	No	No	Device keeps operating at 400-kHz switching frequency for boost converter and 305 Hz for PWM dimming frequency.

表 7-9. Fault and Protection Schemes (continued)

FAULT NAME	STATUS BIT	CONDITION	TRIGGER FAULT INTERRUPT	ENTER FAULT RECOVERY	ACTION
ISET resistor fault	ISET_STATUS	ISET pin voltage is pulled down to below 1V due to ISET pin resistor shorted to GND	Yes	No	LED_CURRENT[11:0] is written to 0x3FF. Total LED current limited to 70 mA.
Thermal shutdown	TSD_STATUS	Junction temperature rises above $T_{SD}$ threshold.	Yes	Yes	Device goes to standby and then attempts to restart once die temperature falls below threshold.
Open LED string	LED_STATUS OPEN_LED	Headroom voltage on one or more channels is below minimum level and boost has adapted to maximum level.	Yes	No	Faulted LED string is disabled and removed from adaptive boost control loop. String is re-enabled next power cycle.
LED internal short	LED_STATUS_SHORT_LED	Headroom voltage on one or more channels is above the SHORTED_LED_THRESHOLD for > 5 ms while the headroom of at least one channel is still below this threshold.	Yes	No	Faulted LED string is disabled and removed from adaptive boost control loop. String is re-enabled next power cycle.
LED short to GND	LED_STATUS_GND_LED	During PL FET SOFT START, voltage of one or more used LED output is below $V_{HEADROOM}$ when small test current is injected. In BOOST_SU and Normal Stage, voltage of one or more used LED output is below $V_{SHORTGND}$ and keeps still when the corresponding channel is off and small test current is injected.	Yes	Yes	Device goes to Fault Recovery and then attempts to restart 100 ms after fault occurs.
Invalid LED string detected	INVSTRING_STATUS	Configured unused LED output is detected not short to GND.	Yes	No	Device functions normally, if possible.
I2C timeout	I2C_ERROR_STATUS	Device receives I2C command without STOP signal for 500 ms.	Yes	No	Device functions normally and waits for the next I2C command.

## 7.4 Device Functional Modes

### 7.4.1 State Diagram



图 7-19. State Machine Diagram

#### 7.4.2 Shutdown

When EN is pulled low, boost, power-line FET, and LED outputs are turned off, and the device tries to discharge the boost output for 400 ms. After this, the device is totally turned off.

#### 7.4.3 Device Initialization

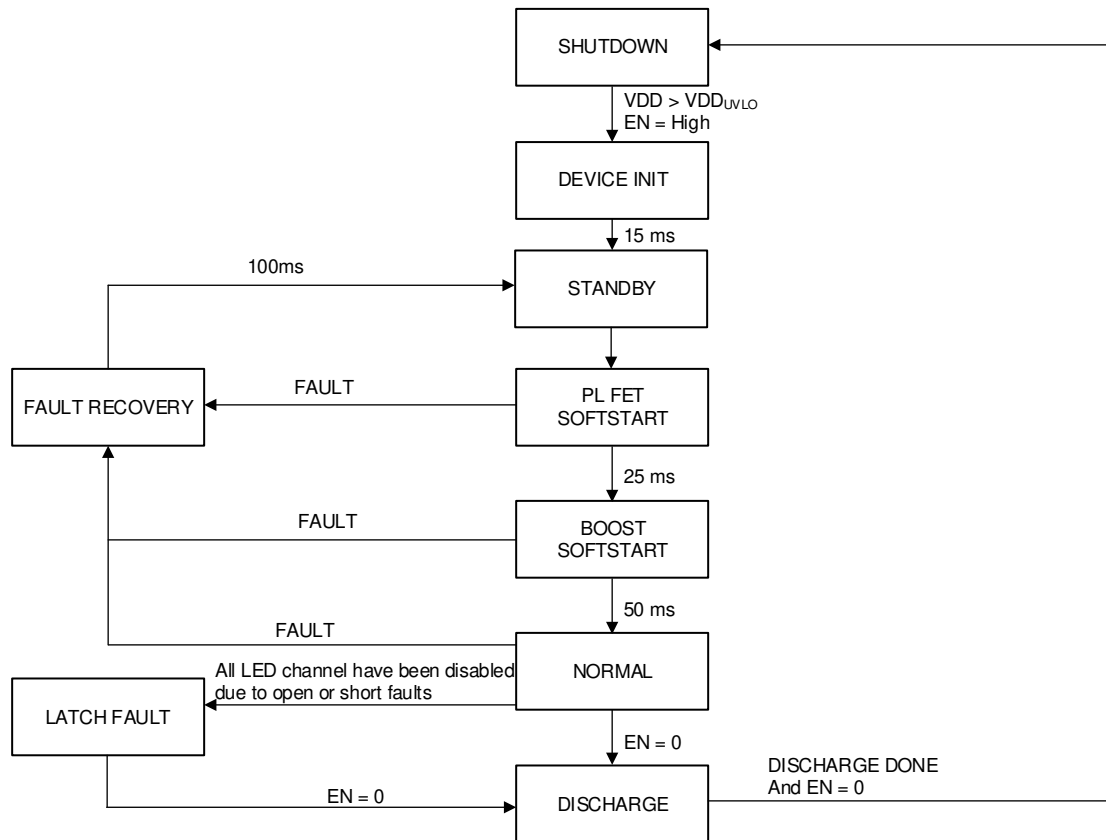
After POR is released device initialization begins. During this state the LDO is started up, EEPROM default and trim configurations are loaded, LEDSET, MODE, BOOST\_FSET and PWM\_FSET resistors are detected.

#### 7.4.4 Standby Mode

Starting from Standby mode, the device can be accessed with I2C to change any configuration registers.

Standby Mode is immediately switched to Power-line FET Soft Start mode if there's no fault.

#### 7.4.5 Power-line FET Soft Start

Power-line FET is gradually enabled during this 25-ms long state. Boost input and output capacitors are charged to  $V_{IN}$  level.  $V_{IN}$  faults for OCP, OVP, and UVP and fault for LED short to GND are enabled.

#### 7.4.6 Boost Start-Up

Boost voltage is ramped to initial boost voltage level with reduced current limit for 50 ms. All boost faults are now enabled.

#### 7.4.7 Normal Mode

LED drivers are enabled when brightness is greater than zero. All LED faults are active.

### 7.4.8 Fault Recovery

Some critical faults can trigger fault recover state. LED drivers, boost converter, and power-line FET are disabled for 100 ms, and the device attempts to restart from standby mode if EN is still high and brightness is greater than zero.

### 7.4.9 Latch Fault

If all LED strings are disabled due to faults then the LP8864S-Q1 enters the latch fault mode. This state can be exited only by pulling the EN pin low.

### 7.4.10 Start-Up Sequence



图 7-20. Start-Up Sequence Diagram

## 7.5 Programming

### 7.5.1 I2C-Compatible Interface

The LP8864S-Q1 device supports I2C interface to access and change the configuration. The 7-bit base slave address is 0x3A or 0x3B. The address could be configured through the resistor settings of MODE pin.

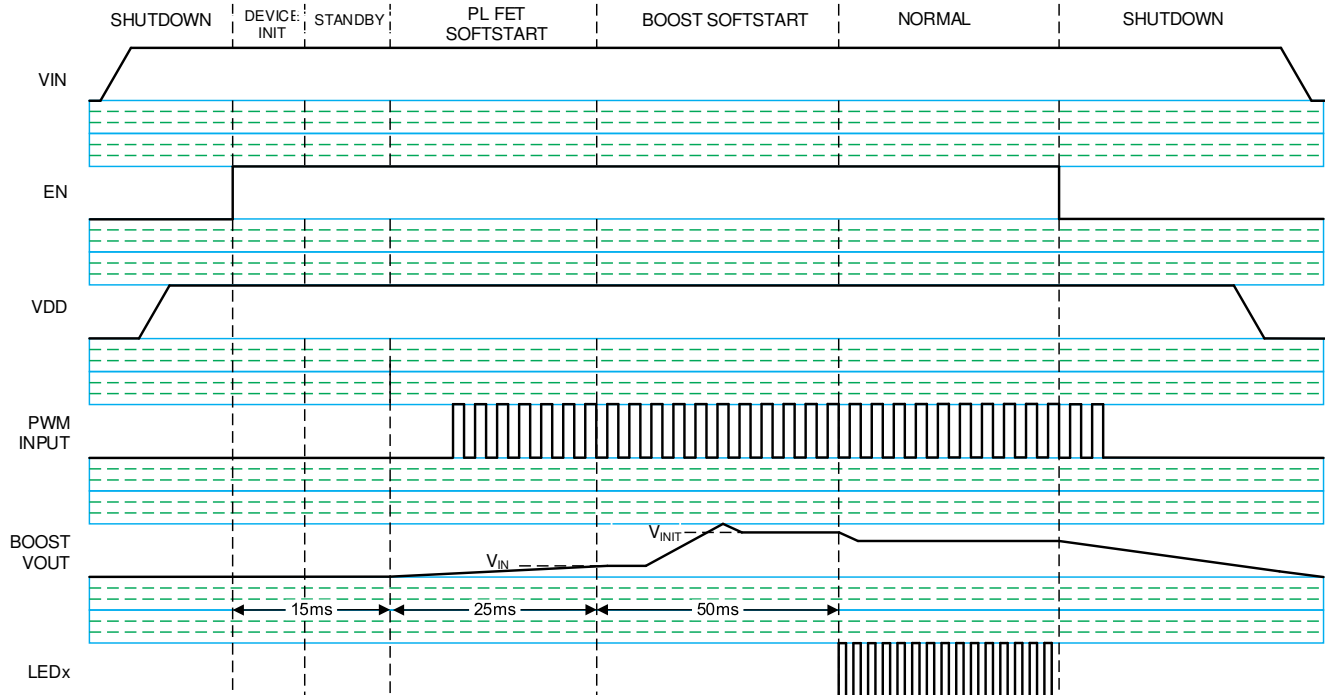
Write I2C transactions are made up of 4 bytes. The first byte includes the 7-bit slave address and Write bit. The 7-bit slave address selects the LP8864S-Q1 slave device. The second byte is eight bits register address. The last two bytes are the 16-bit register value.

Read I2C transactions are made up of 5 bytes. The first byte includes the 7-bit slave address and Write bit. The 7-bit slave address selects the LP8864S-Q1 slave device. The second byte is eight bits register address. The third byte includes the 7-bit slave address and Read bit. The last two bytes are the 16-bit register value returned from the slave.

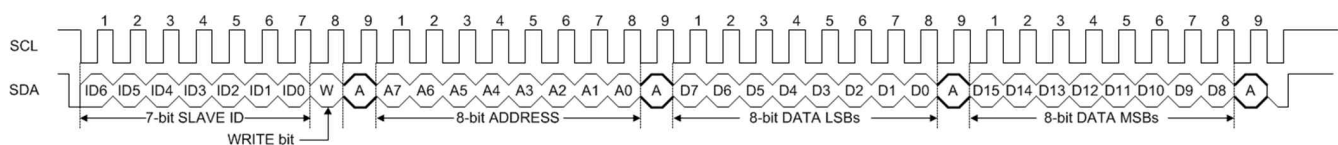

where

- W bit = 1

**图 7-21. I2C Write**

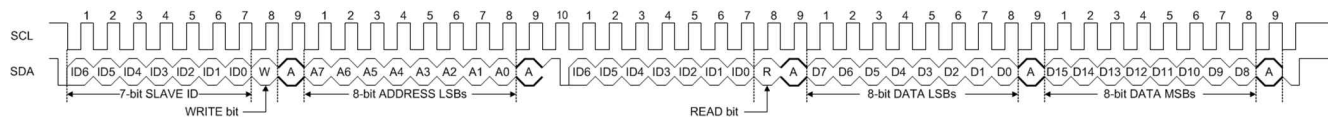

where

- R bit = 0
- W bit = 1

**图 7-22. I2C Read**

## 7.5.2 Programming Examples

### 7.5.2.1 General Configuration Registers

The LP8864S-Q1 does not require any serial interface configuration. It can be simply controlled with the EN pin and PWM pin. Most of the device configuration is accomplished using external resistor values. If I2C interface is available then extended configuration is possible. The configuration registers can be written from standby state to normal state as shown in [表 7-10](#).

**表 7-10. Configuration Registers**

REGISTER NAME	FUNCTION
ADV_SLOPE_ENABLE	Enables advance sloper S-shape smoothing function.
DITHER_SELECT	Selects up to 3 bits of PWM dither for added dimming resolution.
SLOPE_SELECT	Selects duration for linear brightness sloper.
BRT_MODE	Selects PWM pin or DISPLAY_BRT register for brightness control.
SPREAD_RANGE	Selects up to 2 bits boost switching frequency spread spectrum range.
SPREAD_MOD_FREQ	Selects up to 2 bits boost switching frequency spread spectrum modulation frequency.
SPREAD_PSEUDO_EN	Enables pseudo random modulation for boost switching spread spectrum frequency.

### 7.5.2.2 Clearing Fault Interrupts

The LP8864S-Q1 has an INT pin to alert the host when a fault occurs. If I2C interface is available, the Interrupt Fault Status registers can be read back to learn which fault(s) have been detected. These status bits are located in the SUPPLY\_STATUS, BOOST\_STATUS and LED\_STATUS registers. Each interrupt status has a STATUS bit and a CLEAR bit. To clear a fault interrupt status a 1 must be written to both the STATUS bit and CLEAR bit at the same time.

### 7.5.2.3 Disabling Fault Interrupts

By default, most of the LP8864S-Q1 faults trigger the INT pin. Each fault has two INT\_EN bits. These bits are located in the SUPPLY\_INT\_EN, BOOST\_INT\_EN, and LED\_INT\_EN registers. If the INT\_EN bit is read and returns 2b'10, the INT pin is triggered when that fault occurs. The fault interrupt can be disabled by writing 2b'01 to its INT\_EN bits, or it can be enabled by writing 2b'11 to its INT\_EN bits. There is also a GLOBAL fault interrupt that can be disabled to prevent any faults from triggering the INT pin.

### 7.5.2.4 Diagnostic Registers

The LP8864S-Q1 contains several diagnostic registers than can be read with the serial interface for debugging or additional device information. [表 7-11](#) is a summary of the available registers.

**表 7-11. Diagnostic Registers**

REGISTER NAME	FUNCTION
FSM_LIVE_STATUS	Current state of the functional state machine
PWM_INPUT_STATUS	Measured 16-bit duty cycle of the PWM pin input
LED_PWM_STATUS	16-bit LED PWM duty cycle from state machine
LED_CURRENT_STATUS	12-bit LED current DAC value from state machine
VBOOST_STATUS	10-bit value for adaptive boost voltage target — value is linear between VBOOST_MIN and VBOOST_MAX calculations
MODE_SEL_CFG	Dimming mode configuration from MODE detection
LED_STRING_CFG	LED string phase configuration from LEDSET detection
BOOST_FREQ_SEL	Boost switching frequency value from BST_FSET detection
PWM_FREQ_SEL	LED PWM frequency value from PWM_FSET detection

## 7.6 Register Maps

### 7.6.1 FullMap Registers

表 7-12 lists the memory-mapped registers for the FullMap registers. All register offset addresses not listed in 表 7-12 should be considered as reserved locations and the register contents should not be modified.

表 7-12. FULLMAP Registers

Offset	Acronym	Register Name	Section
00h	BRT_CONTROL	Display Brightness	<a href="#">Go</a>
02h	LED_CURR_CONFIG	LED Current	<a href="#">Go</a>
04h	USER_CONFIG1	User Config 1	<a href="#">Go</a>
06h	USER_CONFIG2	User Config 2	<a href="#">Go</a>
08h	SUPPLY_INT_EN	Supply Interrupt Enable	<a href="#">Go</a>
0Ah	BOOST_INT_EN	Boost Interrupt Enable	<a href="#">Go</a>
0Ch	LED_INT_EN	LED Interrupt Enable	<a href="#">Go</a>
0Eh	SUPPLY_STATUS	Supply Fault Status	<a href="#">Go</a>
10h	BOOST_STATUS	Boost Fault Status	<a href="#">Go</a>
12h	LED_STATUS	LED Fault Status	<a href="#">Go</a>
14h	FSM_DIAGNOSTICS	Device State Diagnostics	<a href="#">Go</a>
16h	PWM_INPUT_DIAGNOSTICS	PWM Input Diagnostics	<a href="#">Go</a>
18h	PWM_OUTPUT_DIAGNOSTICS	PWM Output Diagnostics	<a href="#">Go</a>
1Ah	LED_CURR_DIAGNOSTICS	LED Current Diagnostics	<a href="#">Go</a>
1Ch	ADAPT_BOOST_DIAGNOSTICS	Adaptive Boost Diagnostics	<a href="#">Go</a>
1Eh	AUTO_DETECT_DIAGNOSTICS	Auto Detect Diagnostics	<a href="#">Go</a>

Complex bit access types are encoded to fit into small table cells. 表 7-13 shows the codes that are used for access types in this section.

表 7-13. FullMap Access Type Codes

Access Type	Code	Description
Read Type		
R	R	Read
Write Type		
W	W	Write
Reset or Default Value		
- n		Value after reset or the default value

#### 7.6.1.1 BRT\_CONTROL Register (Offset = 00h) [reset = 0h]

BRT\_CONTROL is shown in 图 7-23 and described in 表 7-14.

Return to [Summary Table](#).

图 7-23. BRT\_CONTROL Register

15	14	13	12	11	10	9	8	7	6	5	4	3	2	1	0
DISPLAY_BRT															
R/W-0h															

表 7-14. BRT\_CONTROL Register Field Descriptions

Bit	Field	Type	Reset	Description
15-0	DISPLAY_BRT	R/W	0h	Display Brightness Register

### 7.6.1.2 LED\_CURR\_CONFIG Register (Offset = 02h) [reset = 0FFFh]

LED\_CURR\_CONFIG is shown in 图 7-24 and described in 表 7-15.

Return to [Summary Table](#).

图 7-24. LED\_CURR\_CONFIG Register

15	14	13	12	11	10	9	8	7	6	5	4	3	2	1	0
RESERVED				LED_CURRENT											
R/W-0h				R/W-FFFh											

表 7-15. LED\_CURR\_CONFIG Register Field Descriptions

Bit	Field	Type	Reset	Description
15-12	RESERVED	R/W	0h	These bits are reserved.
11-0	LED_CURRENT	R/W	FFFh	LED current control for all LED outputs

### 7.6.1.3 USER\_CONFIG1 Register (Offset = 04h) [reset = 8A3h]

USER\_CONFIG1 is shown in 图 7-25 and described in 表 7-16.

Return to [Summary Table](#).

图 7-25. GROUPING1 Register

15	14	13	12	11	10	9	8
RESERVED	SPREAD_PSEUDO_EN	SPREAD_MOD_FREQ	SPREAD_RANGE	BRT_MODE			
R/W-0h	R/W-0h	R/W-0h	R/W-2h	R/W-0h			
7	6	5	4	3	2	1	0
SLOPE_SELECT			DITHER_SELECT			ADV_SLOPE_ENABLE	RESERVED
R/W-5h			R/W-0h			R/W-1h	R/W-1h

表 7-16. USER\_CONFIG1 Register Field Descriptions

Bit	Field	Type	Reset	Description
15	RESERVED	R/W	0h	This bit is reserved.
14	SPREAD_PSEUDO_EN	R/W	0h	0h = Pseudo Random SS disabled 1h = Pseudo Random SS enabled
13-12	SPREAD_MOD_FREQ	R/W	0h	Boost spread spectrum modulation frequency 0h = 200 Hz 1h = 500 Hz 2h = 800 Hz 3h = 1.2 kHz
11-10	SPREAD_RANGE	R/W	2h	OSC_BST spread spectrum range 0h = 3.3% 1h = 4.3% 2h = 5.3% 3h = 7.2%

表 7-16. USER\_CONFIG1 Register Field Descriptions (continued)

Bit	Field	Type	Reset	Description
9-8	BRT_MODE	R/W	0h	Select PWM pin or DISPLAY_BRT register for brightness control 0h = Brightness controlled by PWM input 1h = Reserved 2h = Brightness controlled by DISPLAY_BRT register 3h = Reserved
7-5	SLOPE_SELECT	R/W	5h	Select duration for linear brightness sloper 0h = Disabled 1h = 1 ms 2h = 2 ms 3h = 50 ms 4h = 100 ms 5h = 200 ms 6h = 300 ms 7h = 500 ms Times are for linear slope mode. Advanced sloper will increase durations while adding additional smoothing to brightness transitions. 1 ms and 2 ms sloper times are intended to be used only in linear mode. 50 ms to 500 ms sloper durations may be used with or without advanced sloper function.
4-2	DITHER_SELECT	R/W	0h	Dither mode select 0h = Dither Disabled 1h = 1-bit Dither 2h = 2-bit Dither 3h = 3-bit Dither 4h = 4-bit Dither
1	ADV_SLOPE_ENABLE	R/W	1h	0h = Linear Sloping 1h = Advanced Sloping
0	RESERVED	R/W	1h	This bit is reserved.

7.6.1.4 USER\_CONFIG2 Register (Offset = 06h) [reset = 100h]

USER\_CONFIG2 is shown in 图 7-26 and described in 表 7-17.

Return to [Summary Table](#).

图 7-26. USER\_CONFIG2 Register

15	14	13	12	11	10	9	8
RESERVED							EN_LED_GND_DETECT
R/W-0h							R/W-1h
7	6	5	4	3	2	1	0
RESERVED	RESERVED	RESERVED	LED4_SHORT_DISABLE	LED3_SHORT_DISABLE	LED2_SHORT_DISABLE	LED1_SHORT_DISABLE	
R/W-0h	R/W-0h	R/W-0h	R/W-0h	R/W-0h	R/W-0h	R/W-0h	R/W-0h

表 7-17. USER\_CONFIG2 Register Field Descriptions

Bit	Field	Type	Reset	Description
15-9	RESERVED	R/W	0h	These bits are reserved.

表 7-17. USER\_CONFIG2 Register Field Descriptions (continued)

Bit	Field	Type	Reset	Description
8	EN_LED_GND_DETECT	R/W	1h	Enable LED short to ground detection during Boost_SS and normal stage 0h = Disable 1h = Enable
7-6	RESERVED	R/W	0h	These bits must write 0 for normal operation.
5	RESERVED	R/W	0h	This bit must write 0 for normal operation.
4	RESERVED	R/W	0h	This bit must write 0 for normal operation.
3	LED4_SHORT_DISABLE	R/W	0h	Disable LED string4 internal short fault. 0h = Enable 1h = Disable
2	LED3_SHORT_DISABLE	R/W	0h	Disable LED string3 internal short fault. 0h = Enable 1h = Disable
1	LED2_SHORT_DISABLE	R/W	0h	Disable LED string2 internal short fault. 0h = Enable 1h = Disable
0	LED1_SHORT_DISABLE	R/W	0h	Disable LED string1 internal short fault. 0h = Enable 1h = Disable

### 7.6.1.5 SUPPLY\_INT\_EN Register (Offset = 08h) [reset = 2AAAh]

SUPPLY\_INT\_EN is shown in 图 7-27 and described in 表 7-18.

Return to [Summary Table](#).

图 7-27. SUPPLY\_INT\_EN Register

15	14	13	12	11	10	9	8
RESERVED		BSTSYNC_INT_EN		CP_INT_EN		CPCAP_INT_EN	
R/W-0h		R/W-2h		R/W-2h		R/W-2h	
7	6	5	4	3	2	1	0
VINOCP_INT_EN		VDDUVLO_INT_EN		VINOVP_INT_EN		VINUVLO_INT_EN	
R/W-2h		R/W-2h		R/W-2h		R/W-2h	

表 7-18. SUPPLY\_INT\_EN Register Field Descriptions

Bit	Field	Type	Reset	Description
15-14	RESERVED	R/W	0h	These bits are reserved.
13-12	BSTSYNC_INT_EN	R/W	2h	Missing boost sync interrupt enable Read: 0h = Interrupt is currently disabled 2h = Interrupt is currently enabled Write: 1h = Disable interrupt 3h = Enable interrupt

表 7-18. SUPPLY\_INT\_EN Register Field Descriptions (continued)

Bit	Field	Type	Reset	Description
11-10	CP_INT_EN	R/W	2h	Charge pump interrupt enable Read: 0h = Interrupt is currently disabled 2h = Interrupt is currently enabled Write: 1h = Disable interrupt 3h = Enable interrupt
9-8	CPCAP_INT_EN	R/W	2h	Charge pump cap missing interrupt enable Read: 0h = Interrupt is currently disabled 2h = Interrupt is currently enabled Write: 1h = Disable interrupt 3h = Enable interrupt
7-6	VINOCP_INT_EN	R/W	2h	V <sub>IN</sub> over-current interrupt enable Read: 0h = Interrupt is currently disabled 2h = Interrupt is currently enabled Write: 1h = Disable interrupt 3h = Enable interrupt
5-4	VDDUVLO_INT_EN	R/W	2h	V <sub>DD</sub> under-voltage interrupt enable Read: 0h = Interrupt is currently disabled 2h = Interrupt is currently enabled Write: 1h = Disable interrupt 3h = Enable interrupt
3-2	VINOVP_INT_EN	R/W	2h	V <sub>IN</sub> over-voltage interrupt enable Read: 0h = Interrupt is currently disabled 2h = Interrupt is currently enabled Write: 1h = Disable interrupt 3h = Enable interrupt
1-0	VINUVLO_INT_EN	R/W	2h	V <sub>IN</sub> under-voltage interrupt enable Read: 0h = Interrupt is currently disabled 2h = Interrupt is currently enabled Write: 1h = Disable interrupt 3h = Enable interrupt

### 7.6.1.6 BOOST\_INT\_EN Register (Offset = 0Ah) [reset = A028h]

BOOST\_INT\_EN is shown in [图 7-28](#) and described in [表 7-19](#).

Return to [Summary Table](#).

图 7-28. BOOST\_INT\_EN Register

15	14	13	12	11	10	9	8
----	----	----	----	----	----	---	---

图 7-28. BOOST\_INT\_EN Register (continued)

TSD_INT_EN		ISET_INT_EN		LEDSET_INT_EN		MODE_INT_EN	
R/W-2h		R/W-2h		R/W-2h		R/W-2h	
7	6	5	4	3	2	1	0
FSET_INT_EN		BSTOCP_INT_EN		BSTOVPH_INT_EN		Reserved	
R/W-2h		R/W-2h		R/W-2h		R/W-0h	

表 7-19. BOOST\_INT\_EN Register Field Descriptions

Bit	Field	Type	Reset	Description
15-14	TSD_INT_EN	R/W	2h	Thermal shutdown interrupt enable Read: 0h = Interrupt is currently disabled 2h = Interrupt is currently enabled Write: 1h = Disable interrupt 3h = Enable interrupt
13-12	ISET_INT_EN	R/W	2h	ISET resistor short to ground interrupt enable Read: 0h = Interrupt is currently disabled 2h = Interrupt is currently enabled Write: 1h = Disable interrupt 3h = Enable interrupt
11-10	LEDSET_INT_EN	R/W	0h	Missing LEDSET resistor interrupt enable Read: 0h = Interrupt is currently disabled 2h = Interrupt is currently enabled Write: 1h = Disable interrupt 3h = Enable interrupt
9-8	MODE_INT_EN	R/W	0h	Missing MODE resistor interrupt enable Read: 0h = Interrupt is currently disabled 2h = Interrupt is currently enabled Write: 1h = Disable interrupt 3h = Enable interrupt
7-6	FSET_INT_EN	R/W	0h	Missing FSET resistor interrupt enable Read: 0h = Interrupt is currently disabled 2h = Interrupt is currently enabled Write: 1h = Disable interrupt 3h = Enable interrupt
5-4	BSTOCP_INT_EN	R/W	2h	Boost over-current interrupt enable Read: 0h = Interrupt is currently disabled 2h = Interrupt is currently enabled Write: 1h = Disable interrupt 3h = Enable interrupt

表 7-19. BOOST\_INT\_EN Register Field Descriptions (continued)

Bit	Field	Type	Reset	Description
3-2	BSTOVPH_INT_EN	R/W	2h	Boost over-voltage high interrupt enable Read: 0h = Interrupt is currently disabled 2h = Interrupt is currently enabled Write: 1h = Disable interrupt 3h = Enable interrupt
1-0	Reserved	R/W	0h	These bits are reserved.

7.6.1.7 LED\_INT\_EN Register (Offset = 0Ch) [reset = AAh]

LED\_INT\_EN is shown in 图 7-29 and described in 表 7-20.

Return to [Summary Table](#).

图 7-29. LED\_INT\_EN Register



表 7-20. LED\_INT\_EN Register Field Descriptions

Bit	Field	Type	Reset	Description
15-8	RESERVED	R/W	0h	These bits are reserved.
7-6	GLOBAL_INT_EN	R/W	2h	Global interrupt enable Read: 0h = Interrupt is currently disabled 2h = Interrupt is currently enabled Write: 1h = Disable interrupt 3h = Enable interrupt
5-4	I2C_ERROR_INT_EN	R/W	2h	I2C time out interrupt enable Read: 0h = Interrupt is currently disabled 2h = Interrupt is currently enabled Write: 1h = Disable interrupt 3h = Enable interrupt
3-2	INVSTRING_INT_EN	R/W	2h	Invalid LED string configuration interrupt enable Read: 0h = Interrupt is currently disabled 2h = Interrupt is currently enabled Write: 1h = Disable interrupt 3h = Enable interrupt

**表 7-20. LED\_INT\_EN Register Field Descriptions (continued)**

Bit	Field	Type	Reset	Description
1-0	LED_INT_EN	R/W	2h	LED open/internal short/short to GND interrupt enable Read: 0h = Interrupt is currently disabled 2h = Interrupt is currently enabled Write: 1h = Disable interrupt 3h = Enable interrupt

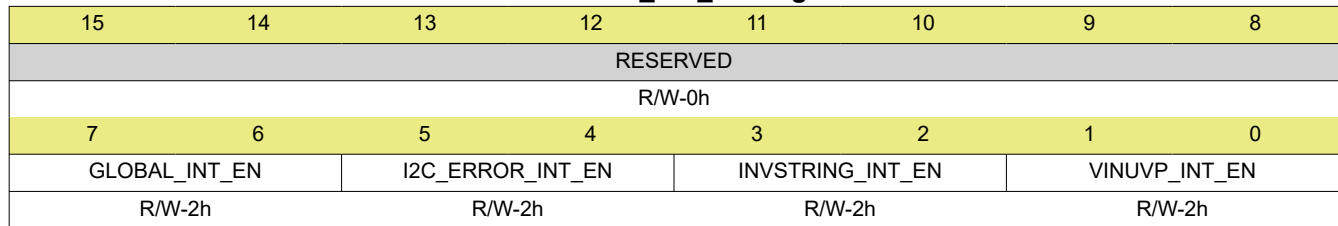
### 7.6.1.8 SUPPLY\_STATUS Register (Offset = 0Eh) [reset = 0h]

SUPPLY\_STATUS is shown in [图 7-30](#) and described in [表 7-21](#).

Return to [Summary Table](#).

**图 7-30. SUPPLY\_STATUS Register**

15	14	13	12	11	10	9	8
CRCERR_STAT US	CRCERR_CLE AR	BSTSYNC_STA TUS	BSTSYNC_CLE AR	CP_STATUS	CP_CLEAR	CPCAP_STATU S	CPCAP_CLEA R
R/W-0h	R/W-0h	R/W-0h	R/W-0h	R/W-0h	R/W-0h	R/W-0h	R/W-0h
7	6	5	4	3	2	1	0
VINOCP_STAT US	VINOCP_CLEA R	VDDUVLO_ST ATUS	VDDUVLO_CL EAR	VINOVP_STAT US	VINOVP_CLEA R	VINUUVLO_STA TUS	VINUUVLO_CLE AR
R/W-0h	R/W-0h	R/W-0h	R/W-0h	R/W-0h	R/W-0h	R/W-0h	R/W-0h

**表 7-21. SUPPLY\_STATUS Register Field Descriptions**

Bit	Field	Type	Reset	Description
15	CRCERR_STATUS	R/W	0h	CRC error fault status 0h = No fault 1h = Fault
14	CRCERR_CLEAR	R/W	0h	CRC error fault clear Write "1" to both Status bit and Clear bit at the same time to clear interrupt register status and interrupt pin status
13	BSTSYNC_STATUS	R/W	0h	Missing boost sync fault status 0h = No fault 1h = Fault
12	BSTSYNC_CLEAR	R/W	0h	Missing boost sync fault clear Write "1" to both Status bit and Clear bit at the same time to clear interrupt register status and interrupt pin status
11	CP_STATUS	R/W	0h	Charge pump fault status 0h = No fault 1h = Fault
10	CP_CLEAR	R/W	0h	Charge pump fault clear Write "1" to both Status bit and Clear bit at the same time to clear interrupt register status and interrupt pin status
9	CPCAP_STATUS	R/W	0h	Missing charge pump fault status 0h = No fault 1h = Fault

表 7-21. SUPPLY\_STATUS Register Field Descriptions (continued)

Bit	Field	Type	Reset	Description
8	CPCAP_CLEAR	R/W	0h	Missing charge pump fault clear Write "1" to both Status bit and Clear bit at the same time to clear interrupt register status and interrupt pin status
7	VINOCP_STATUS	R/W	0h	V <sub>IN</sub> over-current fault status 0h = No fault 1h = Fault
6	VINOCP_CLEAR	R/W	0h	V <sub>IN</sub> over-current fault clear Write "1" to both Status bit and Clear bit at the same time to clear interrupt register status and interrupt pin status
5	VDDUVLO_STATUS	R/W	0h	V <sub>DD</sub> under-voltage fault status 0h = No fault 1h = Fault
4	VDDUVLO_CLEAR	R/W	0h	V <sub>DD</sub> under-voltage fault clear Write "1" to both Status bit and Clear bit at the same time to clear interrupt register status and interrupt pin status
3	VINOVP_STATUS	R/W	0h	V <sub>IN</sub> over-voltage fault status 0h = No fault 1h = Fault
2	VINOVP_CLEAR	R/W	0h	V <sub>IN</sub> over-voltage fault clear Write "1" to both Status bit and Clear bit at the same time to clear interrupt register status and interrupt pin status
1	VINUVLO_STATUS	R/W	0h	V <sub>IN</sub> under-voltage fault status 0h = No fault 1h = Fault
0	VINUVLO_CLEAR	R/W	0h	V <sub>IN</sub> under-voltage fault clear Write "1" to both Status bit and Clear bit at the same time to clear interrupt register status and interrupt pin status

7.6.1.9 BOOST\_STATUS Register (Offset = 10h) [reset = 0h]

BOOST\_STATUS is shown in 图 7-31 and described in 表 7-22.

Return to [Summary Table](#).

图 7-31. BOOST\_STATUS Register

15	14	13	12	11	10	9	8
TSD_STATUS	TSD_CLEAR	ISSET_STATUS	ISSET_CLEAR	LEDSET_STAT US	LEDSET_CLEA R	MODESEL_ST ATUS	MODESEL_CL EAR
R/W-0h	R/W-0h	R/W-0h	R/W-0h	R/W-0h	R/W-0h	R/W-0h	R/W-0h
7	6	5	4	3	2	1	0
FSET_STATUS	FSET_CLEAR	BSTOCP_STAT US	BSTOCP_CLE AR	BSTOVPH_STA TUS	BSTOVPH_CL EAR	BSTOVPL_STA TUS	BSTOVPL_CLE AR
R/W-0h	R/W-0h	R/W-0h	R/W-0h	R/W-0h	R/W-0h	R/W-0h	R/W-0h

表 7-22. BOOST\_STATUS Register Field Descriptions

Bit	Field	Type	Reset	Description
15	TSD_STATUS	R/W	0h	Thermal shutdown fault status 0h = No fault 1h = Fault

**表 7-22. BOOST\_STATUS Register Field Descriptions (continued)**

Bit	Field	Type	Reset	Description
14	TSD_CLEAR	R/W	0h	Thermal shutdown fault clear Write "1" to both Status bit and Clear bit at the same time to clear interrupt register status and interrupt pin status
13	ISET_STATUS	R/W	0h	ISET resistor short to ground fault status 0h = No fault 1h = Fault
12	ISET_CLEAR	R/W	0h	ISET resistor short to ground fault clear Write "1" to both Status bit and Clear bit at the same time to clear interrupt register status and interrupt pin status
11	LEDSET_STATUS	R/W	0h	Missing LED resistor fault status 0h = No fault 1h = Fault
10	LEDSET_CLEAR	R/W	0h	Missing LED resistor fault clear Write "1" to both Status bit and Clear bit at the same time to clear interrupt register status and interrupt pin status
9	MODESEL_STATUS	R/W	0h	Missing MODE SEL resistor fault status 0h = No fault 1h = Fault
8	MODESEL_CLEAR	R/W	0h	Missing MODE SEL resistor fault clear Write "1" to both Status bit and Clear bit at the same time to clear interrupt register status and interrupt pin status
7	FSET_STATUS	R/W	0h	Missing boost FSET resistor fault status 0h = No fault 1h = Fault
6	FSET_CLEAR	R/W	0h	Missing boost FSET resistor fault clear Write "1" to both Status bit and Clear bit at the same time to clear interrupt register status and interrupt pin status
5	BSTOCP_STATUS	R/W	0h	Boost over-current fault status 0h = No fault 1h = Fault
4	BSTOCP_CLEAR	R/W	0h	Boost over-current fault clear Write "1" to both Status bit and Clear bit at the same time to clear interrupt register status and interrupt pin status
3	BSTOVPH_STATUS	R/W	0h	Boost OVP high fault status 0h = No fault 1h = Fault
2	BSTOVPH_CLEAR	R/W	0h	Boost OVP high fault clear Write "1" to both Status bit and Clear bit at the same time to clear interrupt register status and interrupt pin status
1	BSTOVPL_STATUS	R/W	0h	Boost OVP low fault status 0h = No fault 1h = Fault
0	BSTOVPL_CLEAR	R/W	0h	Boost OVP low fault clear Write "1" to both Status bit and Clear bit at the same time to clear interrupt register status

### 7.6.1.10 LED\_STATUS Register (Offset = 12h) [reset = 0h]

LED\_STATUS is shown in [图 7-32](#) and described in [表 7-23](#).

Return to [Summary Table](#).

**图 7-32. LED\_STATUS Register**

15		14		13		12		11		10		9		8	
RESERVED	I2C_ERROR_S TATUS	I2C_ERROR_C LEAR	INVSTRING_S TATUS	INVSTRING_C LEAR	LED_STATUS	LED_CLEAR	GND_LED								
R/W-0h	R/W-0h	R/W-0h	R/W-0h	R/W-0h	R/W-0h	R/W-0h	R/W-0h		R/W-0h		R/W-0h		R-0h		
7		6		5		4		3		2		1		0	
SHORT_LED	OPEN_LED	RESERVED	RESERVED	LED4_FAULT	LED3_FAULT	LED2_FAULT	LED1_FAULT								
R-0h	R-0h	R-0h	R-0h	R-0h	R-0h	R-0h	R-0h		R-0h		R-0h		R-0h		

**表 7-23. LED\_STATUS Register Field Descriptions**

Bit	Field	Type	Reset	Description
15	RESERVED	R/W	0h	This bit is reserved
14	I2C_ERROR_STATUS	R/W	0h	I2C time out fault status 0h = No fault 1h = Fault
13	I2C_ERROR_CLEAR	R/W	0h	I2C time out fault clear Write "1" to both Status bit and Clear bit at the same time to clear interrupt register status and interrupt pin status
12	INVSTRING_STATUS	R/W	0h	Invalid string configuration fault status 0h = No fault 1h = Fault
11	INVSTRING_CLEAR	R/W	0h	Invalid string configuration fault clear Write "1" to both Status bit and Clear bit at the same time to clear interrupt register status and interrupt pin status
10	LED_STATUS	R/W	0h	LED open/internal short/short to GND fault status 0h = No fault 1h = Fault
9	LED_CLEAR	R/W	0h	LED open/internal short/short to GND fault clear Write "1" to both Status bit and Clear bit at the same time to clear interrupt register status and interrupt pin status
8	GND_LED	R	0h	LED short to GND fault status 0h = No fault 1h = Fault
7	SHORT_LED	R	0h	LED internal short Status 0h = No Fault 1h = Fault Status is cleared with LED_STATUS bit
6	OPEN_LED	R	0h	LED open fault status 0h = No fault 1h = Fault Status is cleared with LED_STATUS bit
5	RESERVED	R	0h	This bit must write 0 for normal operation.
4	RESERVED	R	0h	This bit must write 0 for normal operation.

表 7-23. LED\_STATUS Register Field Descriptions (continued)

Bit	Field	Type	Reset	Description
3	LED4_FAULT	R	0h	LED 4 Status 0h = No Fault 1h = Fault
2	LED3_FAULT	R	0h	LED 3 Status 0h = No Fault 1h = Fault
1	LED2_FAULT	R	0h	LED 2 Status 0h = No Fault 1h = Fault
0	LED1_FAULT	R	0h	LED 1 Status 0h = No Fault 1h = Fault

#### 7.6.1.11 FSM\_DIAGNOSTICS Register (Offset = 14h) [reset = 0h]

FSM\_DIAGNOSTICS is shown in 图 7-33 and described in 表 7-24.

Return to [Summary Table](#).

图 7-33. FSM\_DIAGNOSTICS Register

15	14	13	12	11	10	9	8
RESERVED							
R-0h							
7	6	5	4	3	2	1	0
RESERVED				FSM_LIVE_STATUS			
R-0h				R-0h			

表 7-24. FSM\_DIAGNOSTICS Register Field Descriptions

Bit	Field	Type	Reset	Description
15-5	RESERVED	R	0h	These bits are reserved
4-0	FSM_LIVE_STATUS	R	0h	Current state of the functional state machine 0h = DISABLED 1h = LDO_STARTUP 2h = OTP_READ 3h = STANDBY 4h-Fh = BOOST_STARTUP 10h = NORMAL 11h = SHUTDOWN 12h = FAULT_RECOVERY 13h = ALL_LED_FAULT

#### 7.6.1.12 PWM\_INPUT\_DIAGNOSTICS Register (Offset = 16h) [reset = 0h]

PWM\_INPUT\_DIAGNOSTICS is shown in 图 7-34 and described in 表 7-25.

Return to [Summary Table](#).

图 7-34. PWM\_INPUT\_DIAGNOSTICS Register

15	14	13	12	11	10	9	8	7	6	5	4	3	2	1	0
PWM_INPUT_STATUS															

图 7-34. PWM\_INPUT\_DIAGNOSTICS Register (continued)

R-0h

表 7-25. PWM\_INPUT\_DIAGNOSTICS Register Field Descriptions

Bit	Field	Type	Reset	Description
15-0	PWM_INPUT_STATUS	R	0h	16-bit value for detected duty cycle of PWM input signal.

### 7.6.1.13 PWM\_OUTPUT\_DIAGNOSTICS Register (Offset = 18h) [reset = 0h]

PWM\_OUTPUT\_DIAGNOSTICS is shown in 图 7-35 and described in 表 7-26.

Return to [Summary Table](#).

图 7-35. PWM\_OUTPUT\_DIAGNOSTICS Register

15	14	13	12	11	10	9	8	7	6	5	4	3	2	1	0
PWM_OUTPUT_STATUS															
R-0h															

表 7-26. PWM\_OUTPUT\_DIAGNOSTICS Register Field Descriptions

Bit	Field	Type	Reset	Description
15-0	PWM_OUTPUT_STATUS	R	0h	16-bit value for configured duty cycle of PWM output signal.

### 7.6.1.14 LED\_CURR\_DIAGNOSTICS Register (Offset = 1Ah) [reset = 0h]

LED\_CURR\_DIAGNOSTICS is shown in 图 7-36 and described in 表 7-27.

Return to [Summary Table](#).

图 7-36. LED\_CURR\_DIAGNOSTICS Register

15	14	13	12	11	10	9	8
RESERVED				LED_CURRENT_STATUS			
R-0h				R-0h			
7	6	5	4	3	2	1	0
LED_CURRENT_STATUS							
R-0h							

表 7-27. LED\_CURR\_DIAGNOSTICS Register Field Descriptions

Bit	Field	Type	Reset	Description
15-12	RESERVED	R	0h	These bits are reserved.
11-0	LED_CURRENT_STATUS	R	0h	12-bit Current DAC Code that Brightness path is driving to OUT1-4 output.

### 7.6.1.15 ADAPT\_BOOST\_DIAGNOSTICS Register (Offset = 1Ch) [reset = 0h]

ADAPT\_BOOST\_DIAGNOSTICS is shown in 图 7-37 and described in 表 7-28.

Return to [Summary Table](#).

图 7-37. ADAPT\_BOOST\_DIAGNOSTICS Register

15	14	13	12	11	10	9	8
RESERVED				VBOOST_STATUS			
R-0h				R-0h			
7	6	5	4	3	2	1	0

图 7-37. ADAPT\_BOOST\_DIAGNOSTICS Register (continued)

VBOOST_STATUS
R-0h

表 7-28. ADAPT\_BOOST\_DIAGNOSTICS Register Field Descriptions

Bit	Field	Type	Reset	Description
15-11	RESERVED	R	0h	These bits are reserved.
10-0	VBOOST_STATUS	R	0h	11-bit Boost Voltage Code that Adaptive Voltage Control Loop sending to Analog Boost Block. In two-resistor method, Boost Output Voltage = $((1+R1/R2)*1.21V) + (R1*18.9nA*VBOOST\_STATUS)$

### 7.6.1.16 AUTO\_DETECT\_DIAGNOSTICS Register (Offset = 1Eh) [reset = 0h]

AUTO\_DETECT\_DIAGNOSTICS is shown in 图 7-38 and described in 表 7-29.

Return to [Summary Table](#).

图 7-38. AUTO\_DETECT\_DIAGNOSTICS Register

15	14	13	12	11	10	9	8
RESERVED	AUTO_PWM_FREQ_SEL			RESERVED	AUTO_LED_STRING_CFG		
R-0h	R-0h			R-1 1h	R-0h		
7	6	5	4	3	2	1	0
RESERVED		AUTO_BOOST_FREQ_SEL			MODE_SEL		
R-0h		R-0h			R-0h		

表 7-29. AUTO\_DETECT\_DIAGNOSTICS Register Field Descriptions

Bit	Field	Type	Reset	Description
15	RESERVED	R	0h	This bit is reserved
14-12	AUTO_PWM_FREQ_SEL	R	0h	LED PWM frequency value from PWM_SEL resistor detection 0h = 152 Hz 1h = 305 Hz 2h = 610 Hz 3h = 1221 Hz 4h = 2441 Hz 5h = 4883 Hz 6h = 9766 Hz 7h = 19531 Hz
11	RESERVED	R	1 1h	This bit is reserved
10-8	AUTO_LED_STRING_CFG	R	0h	LED string configuration from LED_SET resistor detection 0h = 4 separate strings 1h = 3 separate strings 2h = 2 separate strings 3h = 4 channel outputs connected in 2 groups to drive 2 strings 4h = 4 channel outputs connected together to drive 1 string
7-6	RESERVED	R	0h	These bits are reserved

表 7-29. AUTO\_DETECT\_DIAGNOSTICS Register Field Descriptions (continued)

Bit	Field	Type	Reset	Description
5-3	AUTO_BOOST_FREQ_SEL	R	0h	Boost switching frequency value from PWM_FSET resistor detection 0h = 100 kHz 1h = 200 kHz 2h = 303 kHz 3h = 400 kHz 4h = 500 kHz 5h = 1818 kHz 6h = 2000 kHz 7h = 2222 kHz
2-0	MODE_SEL	R	0h	LED dimming MODE value from MODE detection 0h = PWM mode, I2C address 0x3B 1h = 12.5% hybrid dimming mode, I2C address 0x3B 2h = Constant current mode, I2C address 0x3B 3h = Direct PWM, I2C address 0x3B 4h = PWM mode, I2C address 0x3A 5h = 12.5% hybrid dimming mode, I2C address 0x3A 6h = Constant current mode, I2C address 0x3A 7h = Direct PWM, I2C address 0x3A

## 8 Application and Implementation

### Note

以下应用部分中的信息不属于 TI 器件规格的范围，TI 不担保其准确性和完整性。TI 的客户应负责确定器件是否适用于其应用。客户应验证并测试其设计，以确保系统功能。

### 8.1 Application Information

The LP8864S-Q1 device is designed for automotive applications, and an input voltage  $V_{IN}$  is intended to be connected to the vehicle battery. Depending on the input voltage, the device may be used in either boost mode or SEPIC mode. The device is internally powered from the VDD pin, and voltage must be in 2.7-V to 5.5-V range. The device has flexible configurability through external components or by an I2C interface. If the VDD voltage is not high enough to drive an external nMOSFET gate, an internal charge pump must be used to power the gate driver (GD pin).

### 8.2 Typical Applications

#### 8.2.1 Full Feature Application for Display Backlight

图 8-1 shows a full application for the LP8864S-Q1 device in a boost topology. It supports 6 LED strings in display mode, each at 150 mA, with an automatic 60° phase shift. Brightness control register is used for LED dimming method through I2C communication. The charge pump is enabled for a 400-kHz boost switching frequency with spread spectrum.



图 8-1. Full Feature Application for Display Backlight

#### 8.2.1.1 Design Requirements

This typical LED-driver application is designed to meet the parameters listed in 表 8-1:

表 8-1. LP8864S-Q1 Full-Feature Design Parameters

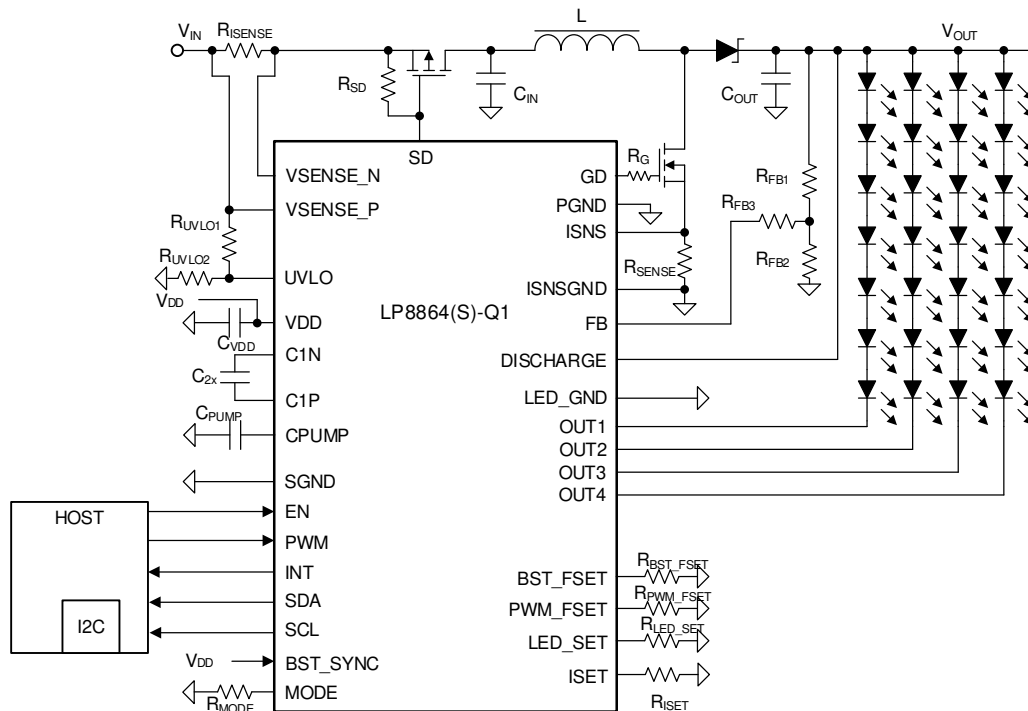
DESIGN PARAMETER	VALUE
VIN voltage range	5 V to 20 V (Quiescent Voltage)
VDD voltage	3.3 V

表 8-1. LP8864S-Q1 Full-Feature Design Parameters (continued)

DESIGN PARAMETER	VALUE
LED strings configuration	4 strings, 7 LEDs in series
Charge pump	Enabled
Brightness control	I2C
Output configuration	OUT1 to OUT4 are in phase shift mode (90°)
LED string current	150 mA
Boost frequency	400 kHz
Inductor	22 µH at 6.5-A saturation current
R <sub>ISENSE</sub>	20 m Ω
Power-line FET	Enabled
R <sub>SENSE</sub>	30 m Ω
Input/Output capacitors	C <sub>IN</sub> and C <sub>OUT</sub> : 1 × 33-µF electrolytic + 1 × 10-µF ceramic
Spread spectrum	Enabled
Discharge function	Enabled

### 8.2.1.2 Detailed Design Procedure

#### 8.2.1.2.1 Inductor Selection

There are a few things to consider when choosing an inductor: inductance, current rating, and DC resistance (DCR). 表 8-2 shows recommended inductor values for each operating frequency. The LP8864S-Q1 device automatically sets internal boost compensation controls depending on the selected switching frequency.

表 8-2. Inductance Values for Boost Switching Frequencies

SW FREQUENCY (kHz)	INDUCTANCE (µH)
100	47
200	33
303	22
400	22
500	22
1818	10
2000	10
2222	10

The current rating of inductor must be at least 25% higher than maximum boost switching current  $I_{SW(max)}$ , which can be calculated with Equation 21. TI recommends to use an inductor with low DCR to achieve good efficiency. Efficiency varies with load condition, switching frequency, and components. 80% can be used as a typical estimation. 65% efficiency needs to take into account in extreme condition.

$$I_{SW(max)} = \frac{\Delta I_L}{2} + \frac{I_{OUT(max)}}{1 - D} \quad (21)$$

where

- $\Delta I_L = V_{IN(min)} \times D / f_{SW} \times L$
- $D = 1 - V_{IN(min)} \times \eta / V_{OUT}$
- $I_{SW(max)}$ : Maximum switching current
- $\Delta I_L$ : Inductor ripple current
- $I_{OUT(max)}$ : Maximum output current
- D: Boost duty cycle
- $V_{IN(min)}$ : Minimum input voltage

- $f_{SW}$ : Minimum switching frequency of the converter
- L: Inductance
- $V_{OUT}$ : Output voltage
- $\eta$ : Efficiency of boost converter

#### 8.2.1.2.2 Output Capacitor Selection

Recommended voltage rating for output capacitors is 50% higher than maximum output voltage level. Capacitance value determines voltage ripple and boost stability. The DC-bias effect can reduce the effective capacitance significantly, by up to 80%, a consideration for capacitance value selection. The conservative target effective capacitance is 50  $\mu$ F to achieve good phase and gain margin levels. A design table in product webpage could be referred for the target effective capacitance in a certain application. TI recommends using 33- $\mu$ F Al-polymer electrolytic capacitor together with 10- $\mu$ F ceramic capacitors in parallel to reduce ripple, increase stability, and reduce ESR effect.

#### 8.2.1.2.3 Input Capacitor Selection

Recommended input capacitance is the same as output capacitance although input capacitors are not as critical to boost operation. Input capacitance can be reduced but must ensure enough filtering for input power.

#### 8.2.1.2.4 Charge Pump Output Capacitor

TI recommends a ceramic capacitor with at least 10-V voltage rating for the output capacitor of the charge pump. A 10- $\mu$ F capacitor can be used for most applications.

#### 8.2.1.2.5 Charge Pump Flying Capacitor

TI recommends a ceramic capacitor with at least 10-V voltage rating for the flying capacitor of the charge pump. One 2.2- $\mu$ F capacitor connecting C1P and C1N pins can be used for most applications.

#### 8.2.1.2.6 Output Diode

A Schottky diode must be used for the boost output diode. Current rating must be at least 25% higher than the maximum output current. Schottky diodes with a low forward drop and fast switching speeds are ideal for increasing efficiency. At maximum current, the forward voltage must be as low as possible; less than 0.5 V is recommended. Reverse breakdown voltage of the Schottky diode must be significantly larger than the output voltage, 25% higher voltage rating is recommended. Do not use ordinary rectifier diodes, because slow switching speeds and long recovery times cause efficiency and load regulation to suffer.

#### 8.2.1.2.7 Switching FET

Gate-drive voltage for the FET is 5V. Switching FET is a critical component for determining power efficiency of the boost converter. Several aspects need to be considered when selecting switching FET such as voltage and current rating,  $R_{DS(on)}$ , power dissipation, thermal resistance and rise/fall times. An N type MOSFET with at least 25% higher voltage rating than maximum output voltage must be used. Current rating of switching FET should be same or higher than inductor rating.  $R_{DS(on)}$  must be as low as possible, less than 20 m $\Omega$  is recommended. Thermal resistance ( $R_{\theta JA}$ ) must also be low to dissipate heat from power loss on switching FET. In most cases, a resistance is recommended between GD pin and Switching FET's gate terminal. It could be used to control the rising/falling time of the switching FET. This gate resistance could offer the flexibility of balancing between EMC performance and efficiency.

#### 8.2.1.2.8 Boost Sense Resistor

The  $R_{SENSE}$  resistor determines the boost overcurrent limit and is sensed every boost switching cycle. A high-power 20-m $\Omega$  resistor can be used for sensing the boost SW current and setting maximum current limit at 10 A (typical).  $R_{SENSE}$  can be increased to lower this limit and can be calculated with [Equation 22](#). In typical condition, to avoid too much efficiency loss on  $R_{SENSE}$  resistor, boost overcurrent limit is recommended to be set above 4A, therefore  $R_{SENSE}$  doesn't exceed 50 m $\Omega$ . Power rating can be calculated from the inductor current and sense resistor resistance value.

$$R_{\text{SENSE}} = \frac{200 \text{ mV}}{I_{\text{BOOST\_OCP}}} \quad (22)$$

where

- $R_{\text{SENSE}}$ : boost sense resistor ( $\text{m}\Omega$ )
- $I_{\text{BOOST\_OCP}}$ : boost overcurrent limit

#### 8.2.1.2.9 Power-Line FET

A power line FET can be used to disconnect input power from boost input to protect the LP8864S-Q1 device and boost components in case an overcurrent event occurs. A P type MOSFET is used for the power-line FET. Voltage rating must be at least 25% higher than maximum input voltage level. Low  $R_{\text{DS(ON)}}$  is important to reduce power loss on the FET — less than 20  $\text{m}\Omega$  is recommended. Current rating for the FET must be at least 25% higher than input peak current. Minimum Gate-to-Source voltage ( $V_{\text{GS}}$ ) to turn on transistor fully must be less than minimum input voltage; use a 20-k  $\Omega$  resistor between the pFET gate and source.

#### 8.2.1.2.10 Input Current Sense Resistor

A high-power resistor can be used for sensing the boost input current. Overcurrent condition is detected when the voltage across  $R_{\text{ISENSE}}$  reaches 220 mV. Typical 20-m  $\Omega$  sense resistor is used to set 11-A input current limit. Sense resistor value can be increased to lower overcurrent limit for application as needed. Power rating can be calculated from the input current and resistance value.

#### 8.2.1.2.11 Feedback Resistor Divider

Feedback resistors  $R_{\text{FB1}}$  and  $R_{\text{FB2}}$  determine the maximum boost output level. Output voltage can be calculated as in [Equation 23](#):

$$V_{\text{OUT\_MAX}} = \left( \frac{V_{\text{BG}}}{R_{\text{FB2}}} + I_{\text{SEL\_MAX}} \right) \times R_{\text{FB1}} + V_{\text{BG}} \quad (23)$$

where

- $V_{\text{BG}} = 1.21 \text{ V}$
- $I_{\text{SEL\_MAX}} = 38.7 \mu\text{A}$
- $R_{\text{FB1}} / R_{\text{FB2}}$  normal recommended range is 7~15

#### 8.2.1.2.12 Critical Components for Design

 [8-2](#) shows the critical part of circuitry: boost components, the LP8864S-Q1 internal charge pump for gate-driver powering, and powering/grounding of LP8864S-Q1. Schematic example is shown in [Figure 8-2](#).

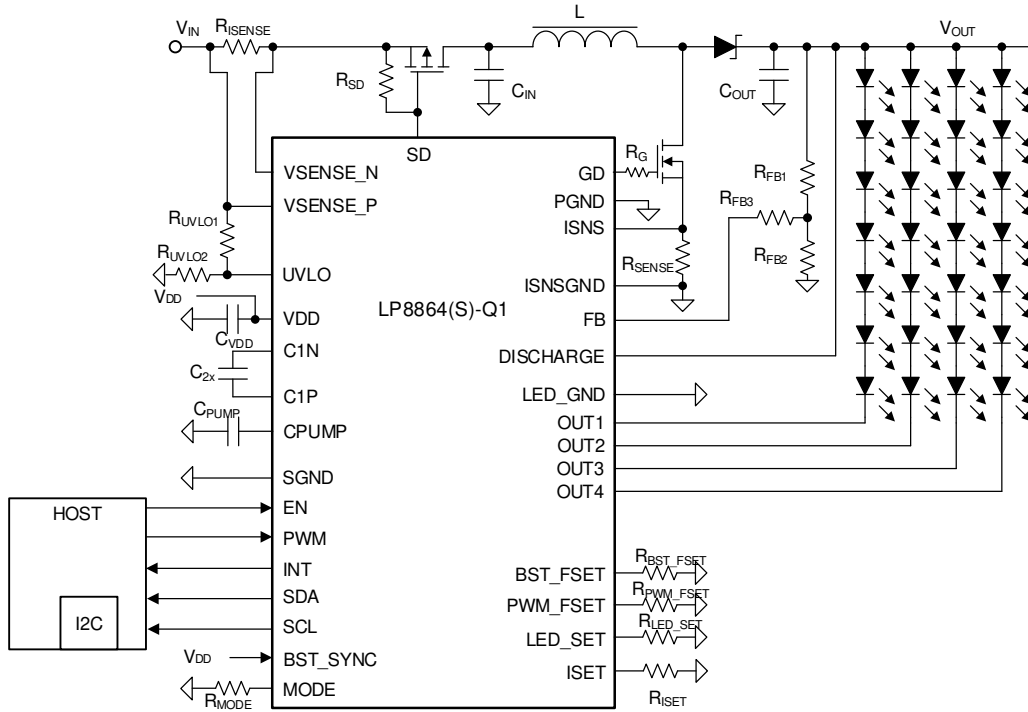

**图 8-2. Critical Components for Full Feature Design**

**表 8-3. Recommended Component Values for Full Feature Design Example**

REFERENCE DESIGNATOR	DESCRIPTION	NOTE
R <sub>ISENSE</sub>	20 mΩ, 3 W	Input current sensing resistor
R <sub>SD</sub>	20 kΩ, 0.1 W	Power-line FET gate pullup resistor
R <sub>SENSE</sub>	30 mΩ, 3 W	Boost current sensing resistor
R <sub>G</sub>	15 Ω, 0.1 W	Gate resistor to control the rising/falling time of nMOSFET for EMC
R <sub>UVLO1</sub>	76.8 kΩ, 0.1 W	These UVLO resistor settings set the VIN_UVLO rising voltage at 3.75 V, VIN_UVLO falling voltage at 3.35 V
R <sub>UVLO2</sub>	20.5 kΩ, 0.1 W	
R <sub>FB3</sub>	0 Ω, 0.1 W	Not needed unless 100-kΩ restrictions on resistors
R <sub>FB2</sub>	100 kΩ, 0.1 W	Bottom feedback divider resistor
R <sub>FB1</sub>	910 kΩ, 0.1 W	Top feedback divider resistor
R <sub>BST_FSET</sub>	3.92 kΩ, 0.1 W	Boost frequency set resistor (400 kHz)
R <sub>ISET</sub>	20.8 kΩ, 0.1 W	Current set resistor (150 mA per channel)
R <sub>PWM_FSET</sub>	17.8 kΩ, 0.1 W	Output PWM frequency set resistor (4.88kHz PWM frequency to avoid audible noise)
R <sub>MODE</sub>	3.92 kΩ, 0.1 W	Mode resistor (Phase-Shift PWM mode with 0x3B I2C address)
R <sub>LED_SET</sub>	3.92 kΩ, 0.1 W	LED_SET resistor (4channels configuration)
C <sub>PUMP</sub>	10-μF, 10-V ceramic	Charge-pump output capacitor
C <sub>2X</sub>	2.2-μF, 10-V ceramic	Flying capacitor
C <sub>VDD</sub>	4.7-μF + 0.1-μF, 10-V ceramic	VDD bypass capacitor
C <sub>IN</sub>	1 × 33-μF, 50-V electrolytic + 1 × 10-μF, 50-V ceramic	Boost input capacitor
C <sub>OUT</sub>	1 × 33-μF, 50-V electrolytic + 1 × 10-μF, 50-V ceramic	Boost output capacitor
L1	22- μ H saturation current 6.5 A	Boost inductor
D1	50 V, 6.5-A Schottky diode	Boost Schottky diode
Q1	60-V, 15-A nMOSFET	Boost nMOSFET
Q2	60-V, 15-A pMOSFET	Power-line FET

**8.2.1.3 Application Curves**

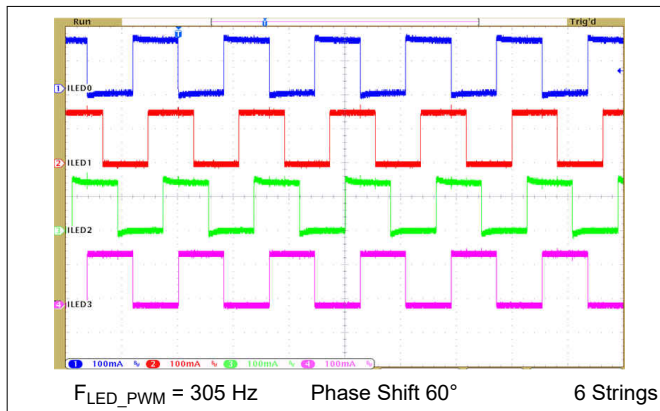

**图 8-3. LED String Currents Showing Phase Shift PWM Operation**

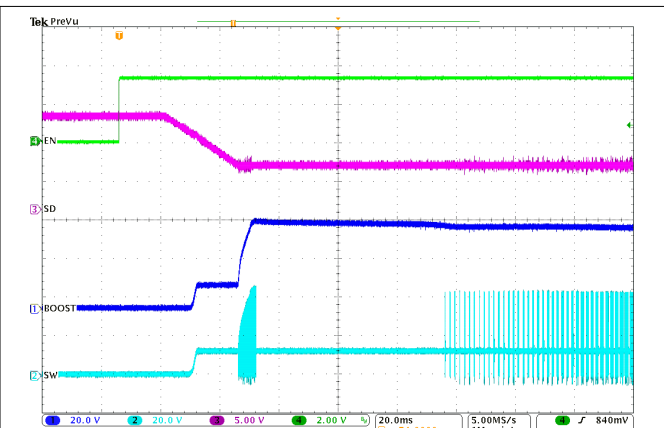

**图 8-4. Typical Start-Up**

### 8.2.2 Application with Basic/Minimal Operation

The LP8864S-Q1 needs only a few external components for basic functionality if material cost and PCB area for a solution need to be minimized. In this example LP8864S-Q1 is configured with external components and no I2C communication. The power-line FET is removed, as is input current sensing. Internal charge pump is not used, and all external synchronization functions and special features are disabled. The 33- $\mu$ F Al-polymer electrolytic capacitor is removed for PCB area and height limitation. And boost external compensation is used to compensate the removal of the 33- $\mu$ F Al-polymer electrolytic capacitor.



图 8-5. Minimal Solution/Minimum Components Application

### 8.2.2.1 Design Requirements

This typical LED-driver application is designed to meet the parameters listed in [表 8-4](#):

**表 8-4. LP8864S-Q1 Minimal Solution Design Parameters**

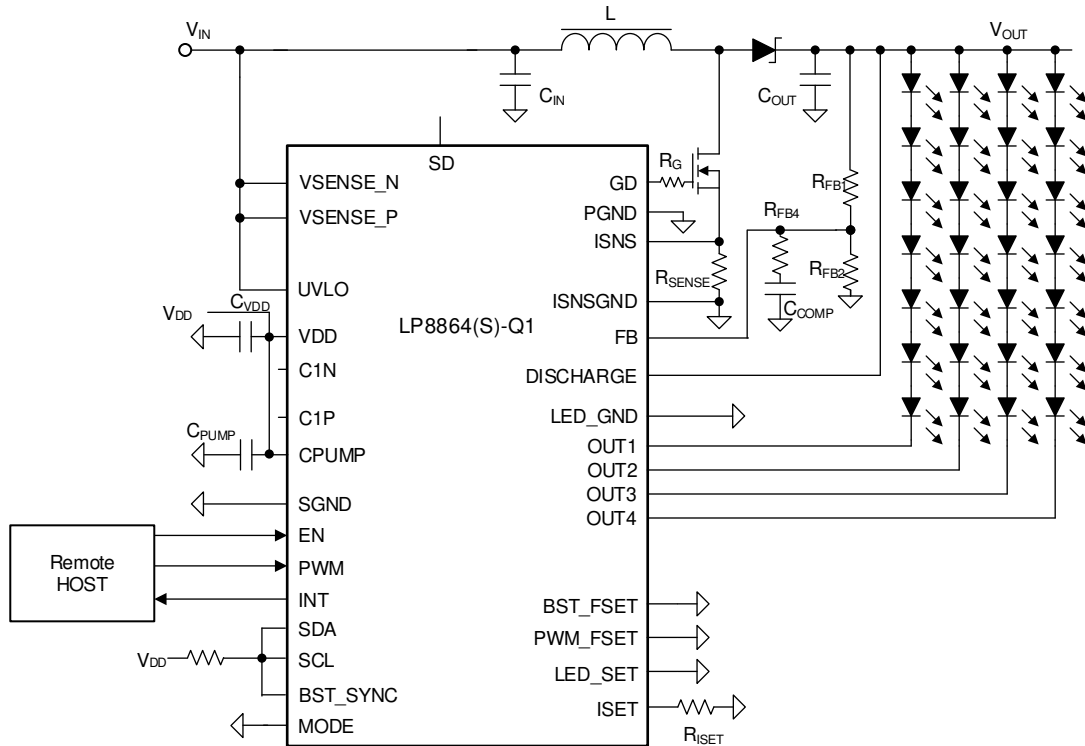
DESIGN PARAMETER	VALUE
VIN voltage range	3 V to 20 V (Quiescent Voltage)
VDD voltage	5 V
LED strings configuration	4 strings, 7 LEDs in series
Charge pump	Disabled
Brightness control	PWM
Output configuration	OUT1 to OUT4 are in phase shift mode (90°)
LED string current	120 mA
Boost frequency	400 kHz
Inductor	22 $\mu$ H at 6.5-A saturation current
R <sub>ISENSE</sub>	20 m $\Omega$
Power-line FET	Enabled
R <sub>SENSE</sub>	30 m $\Omega$
Input/Output capacitors	C <sub>IN</sub> and C <sub>OUT</sub> : 3 $\times$ 10- $\mu$ F ceramic
Spread spectrum	Enabled
Discharge function	Enabled

### 8.2.2.2 Detailed Design Procedure

See [Detailed Design Procedure](#).

### 8.2.2.3 Application Curves

See [Application Curves](#).

### 8.2.3 SEPIC Mode Application

When LED string voltage can be above and below the input voltage level, use the SEPIC configuration. In SEPIC mode, the SW pin detects a maximum voltage equal to the sum of the input and output voltages, a consideration when selecting components.



图 8-6. SEPIC Mode with Three LEDs in Series

### 8.2.3.1 Design Requirements

This typical LED-driver application is designed to meet the parameters listed in [表 8-5](#):

**表 8-5. LP8864S-Q1 SEPIC Mode Design Parameters**

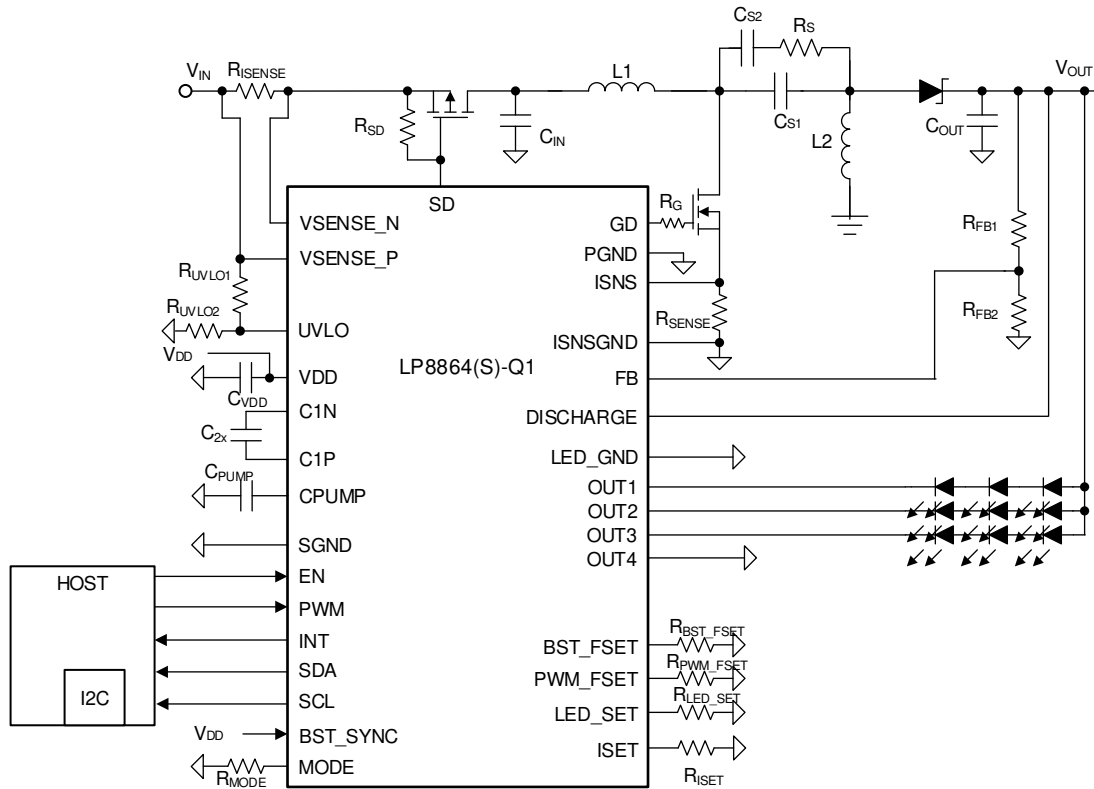
DESIGN PARAMETER	VALUE
V <sub>IN</sub> voltage range	4.5 V to 20 V (quiescent voltage)
V <sub>DD</sub> voltage	3.3 V
LED strings configuration	3 strings, 3 LEDs in series
Charge pump	Enabled
Brightness control	I2C
Output configuration	OUT1 to OUT3 are in phase shift PWM mode
LED string current	80 mA
Boost frequency	2.2 MHz
Inductor	10 µH at 4-A saturation current
R <sub>ISENSE</sub>	20 mΩ
Power-line FET	Enabled
R <sub>SENSE</sub>	50 mΩ
Input/Output capacitors	C <sub>IN</sub> and C <sub>OUT</sub> : 1 × 33-µF electrolytic + 1 × 10-µF ceramic
Spread spectrum	Enabled
Discharge function	Enabled

### 8.2.3.2 Detailed Design Procedure

#### 8.2.3.2.1 Inductor Selection

Inductance for both inductors can be selected from [表 8-6](#), depending on operating frequency for the application. Current rating is recommended to be at least 25% higher than maximum inductor peak current. Peak-to-peak ripple current can be estimated to be approximately 40% of the maximum input current and inductor peak current can be calculated with [Equation 24](#), [Equation 25](#), and [Equation 26](#):

**表 8-6. Inductance Values for SEPIC Switching Frequencies**

SW FREQUENCY (kHz)	INDUCTANCE (µH)
100	22
200	15
303	10
400	10
500	10
1818	4.7
2000	4.7
2222	4.7

$$I_{L1(\text{peak})} = I_{\text{OUT}} \times \frac{V_{\text{OUT}} + V_{\text{D}}}{V_{\text{IN}(\text{min})}} \times \left(1 + \frac{40\%}{2}\right) \quad (24)$$

where

- $I_{L1(\text{peak})}$ : Peak current for inductor 1
- $I_{\text{OUT}}$ : Maximum output current
- $V_{\text{OUT}}$ : Output voltage
- $V_{\text{D}}$ : Diode forward voltage drop
- $V_{\text{IN}(\text{min})}$ : Minimum input voltage

$$I_{L2(\text{peak})} = I_{\text{OUT}} \times \left(1 + \frac{40\%}{2}\right) \quad (25)$$

where

- $I_{L2(\text{peak})}$ : Peak current for inductor 2
- $I_{\text{OUT}}$ : Maximum output current

$$\Delta I_{\text{L}} = I_{\text{IN}} \times 40\% = I_{\text{OUT}} \times \frac{V_{\text{OUT}}}{V_{\text{IN}(\text{min})}} \times 40\% \quad (26)$$

where

- $\Delta I_{\text{L}}$ : Inductor ripple current
- $I_{\text{IN}}$ : Input current
- $V_{\text{OUT}}$ : Output voltage
- $V_{\text{IN}(\text{min})}$ : Minimum input voltage

#### 8.2.3.2.2 Coupling Capacitor Selection

The coupling capacitors  $C_s$  isolate the input from the output and provide protection against a shorted load. The selection of SEPIC capacitors,  $C_s$ , depends mostly on the RMS current, which can be calculated with [Equation 27](#). The capacitors must be rated for a large RMS current relative to the output power; TI recommends at least 25% higher rating for  $I_{\text{RMS}}$ . When using uncoupled inductors, use one 10- $\mu\text{F}$  ceramic capacitor in parallel with one 33- $\mu\text{F}$  electrolytic capacitor and series 2- $\Omega$  resistor. If coupled inductors are used, then use only one 10- $\mu\text{F}$  ceramic capacitor.

$$I_{C_s(\text{rms})} = I_{\text{OUT}} \times \sqrt{\frac{V_{\text{OUT}} + V_{\text{D}}}{V_{\text{IN}(\text{min})}}} \quad (27)$$

where

- $I_{C_s(\text{rms})}$ : RMS current of  $C_s$  capacitor
- $I_{\text{OUT}}$ : Output current
- $V_{\text{OUT}}$ : Output voltage
- $V_{\text{D}}$ : Diode forward voltage drop
- $V_{\text{IN}(\text{min})}$ : Minimum input voltage

#### 8.2.3.2.3 Output Capacitor Selection

See [Detailed Design Procedure](#).

#### 8.2.3.2.4 Input Capacitor Selection

See [Detailed Design Procedure](#).

### 8.2.3.2.5 Charge Pump Output Capacitor

See [Detailed Design Procedure](#).

### 8.2.3.2.6 Charge Pump Flying Capacitor

See [Detailed Design Procedure](#).

### 8.2.3.2.7 Switching FET

Gate-drive voltage for the FET is 5V. Use an N-type MOSFET for the switching FET. The switching FET for SEPIC mode sees a maximum voltage of  $V_{IN(max)} + V_{OUT}$ , 25% higher rating is recommended. Current rating is also recommended to be 25% higher than peak current, which can be calculated with [Equation 28](#).  $R_{DS(on)}$  must be as low as possible — less than 20 m $\Omega$  is recommended. Thermal resistance ( $R_{\theta JA}$ ) must also be low to dissipate heat from power loss on switching FET. Typical rise/fall time values recommended are less than 10 ns.

$$I_{Q1(peak)} = I_{L1(peak)} + I_{L2(peak)} \quad (28)$$

where

- $I_{Q1(peak)}$ : Peak current for switching FET
- $I_{L1(peak)}$ : Peak current for inductor 1
- $I_{L2(peak)}$ : Peak current for inductor 2 BOOST\_OCP

### 8.2.3.2.8 Output Diode

A Schottky diode must be used for the SEPIC output diode. Current rating must be at least 25% higher than the maximum current, which is the same as switch peak current. Schottky diodes with a low forward drop and fast switching speeds are ideal for increasing efficiency. At maximum current, the forward voltage must be as low as possible; TI recommends less than 0.5 V. Reverse breakdown voltage of the Schottky diode must be able to withstand  $V_{IN(max)} + V_{OUT(max)}$ ; at least 25% higher voltage rating is recommended. Do not use ordinary rectifier diodes, because slow switching speeds and long recovery times cause efficiency and load regulation to suffer.

### 8.2.3.2.9 Switching Sense Resistor

See [Detailed Design Procedure](#).

### 8.2.3.2.10 Power-Line FET

See [Detailed Design Procedure](#).

### 8.2.3.2.11 Input Current Sense Resistor

See [Detailed Design Procedure](#).

### 8.2.3.2.12 Feedback Resistor Divider

Feedback resistors  $R_{FB1}$  and  $R_{FB2}$  determine the maximum boost output level. Output voltage can be calculated as follows:

$$V_{OUT\_MAX} = \left( \frac{V_{BG}}{R_{FB2}} + I_{SEL\_MAX} \right) \times R_{FB1} + V_{BG} \quad (29)$$

where

- $V_{BG} = 1.21$  V
- $I_{SEL\_MAX} = 38.7$   $\mu$ A
- $R_{FB1} / R_{FB2}$  normal recommended range is 5~15 (recommended for SEPIC Mode)

### 8.2.3.2.13 Critical Components for Design

shows the critical part of circuitry: SEPIC components, the LP8864S-Q1 internal charge pump for gate-driver powering, and powering/grounding of LP8864S-Q1. Schematic example is shown below.

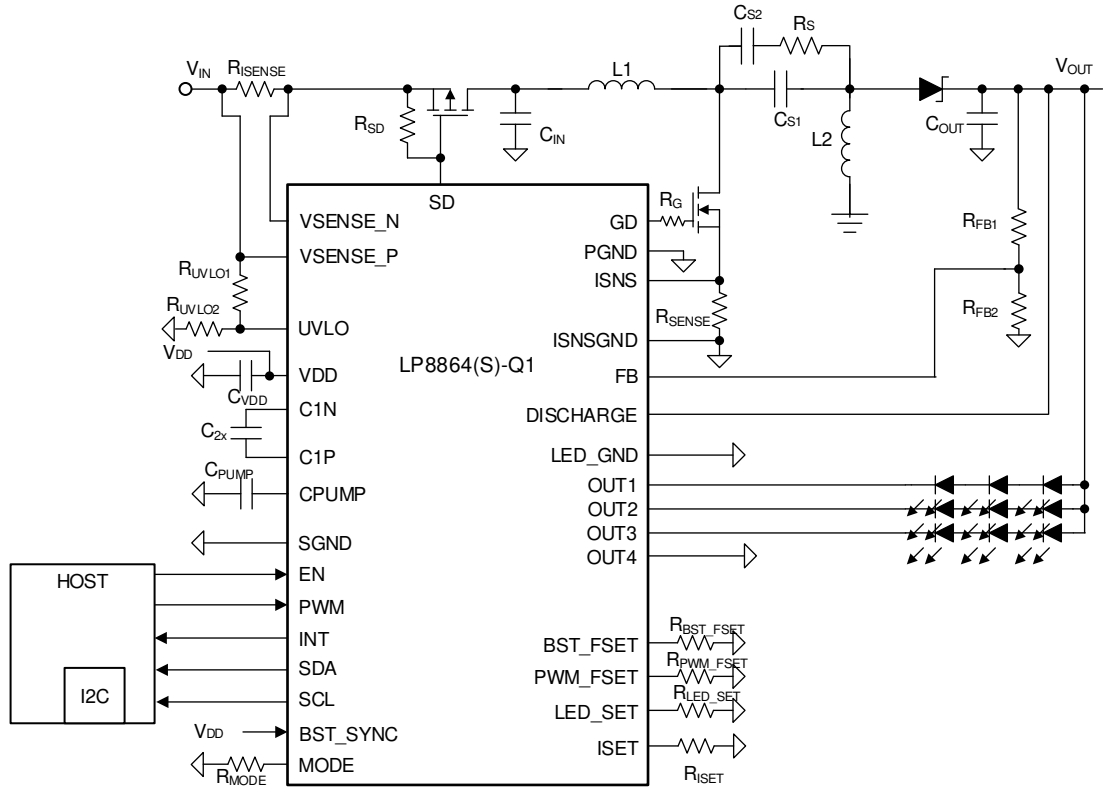

**图 8-7. SEPIC Mode with Three LEDs in Series**

表 8-7. Recommended Components for SEPIC Design Example

REFERENCE DESIGNATOR	DESCRIPTION	NOTE
R <sub>ISENSE</sub>	20 m $\Omega$ , 1 W	Input current sensing resistor
R <sub>SD</sub>	20 k $\Omega$ , 0.1 W	Power-line FET gate pullup resistor
R <sub>SENSE</sub>	50 m $\Omega$ , 1 W	Boost current sensing resistor
R <sub>G</sub>	15 $\Omega$ , 0.1 W	Gate resistor to control the rising/falling time of nMOSFET for EMC
R <sub>UVLO1</sub>	76.8 k $\Omega$ , 0.1 W	These UVLO resistor settings set the VIN_UVLO rising voltage at 3.75 V, VIN_UVLO falling voltage at 3.35 V
R <sub>UVLO2</sub>	20.5 k $\Omega$ , 0.1 W	
R <sub>FB2</sub>	60 k $\Omega$ , 0.1 W	Bottom feedback divider resistor
R <sub>FB1</sub>	330 k $\Omega$ , 0.1 W	Top feedback divider resistor
R <sub>BST_FSET</sub>	124 k $\Omega$ , 0.1 W	Boost frequency set resistor (2200 kHz)
R <sub>ISET</sub>	38.7 k $\Omega$ , 0.1 W	Current set resistor (80 mA per channel)
R <sub>PWM_FSET</sub>	4.75 k $\Omega$ , 0.1 W	Output PWM frequency set resistor (305-Hz PWM frequency)
R <sub>MODE</sub>	3.92 k $\Omega$ , 0.1 W	Mode resistor (Phase-Shift PWM mode with 0x3B I2C address)
R <sub>LED_SET</sub>	4.75 k $\Omega$ , 0.1 W	LED_SET resistor (3 channels configuration)
C <sub>PUMP</sub>	10- $\mu$ F, 10-V ceramic	Charge-pump output capacitor
C <sub>2X</sub>	2.2- $\mu$ F, 10-V ceramic	Flying capacitor
C <sub>VDD</sub>	4.7- $\mu$ F + 0.1- $\mu$ F, 10-V ceramic	VDD bypass capacitor
C <sub>IN</sub>	1 $\times$ 33- $\mu$ F, 50-V electrolytic + 1 $\times$ 10- $\mu$ F, 50-V ceramic	Boost input capacitor
C <sub>OUT</sub>	1 $\times$ 33- $\mu$ F, 50-V electrolytic + 1 $\times$ 10- $\mu$ F, 50-V ceramic	Boost output capacitor
C <sub>S1</sub>	10- $\mu$ F, 50-V ceramic	SEPIC coupling capacitor
C <sub>S2</sub>	33- $\mu$ F, 50-V electrolytic	SEPIC coupling capacitor
RS	2 $\Omega$ , 0.125 W	SEPIC resistor
L1	4.7- $\mu$ H saturation current 3 A	SEPIC inductor
L2	4.7- $\mu$ H saturation current 3 A	SEPIC inductor
D1	50-V 10-A Schottky diode	SEPIC Schottky diode
Q1	60-V, 25-A nMOSFET	SEPIC nMOSFET
Q2	60-V, 30-A pMOSFET	Power-line FET

### 8.2.3.3 Application Curves

See [Application Curves](#).

## 9 Power Supply Recommendations

The LP8864S-Q1 is designed to operate from a car battery. The V<sub>IN</sub> input must be protected from reverse voltage and voltage dump condition over 48 V. The impedance of the input supply rail must be low enough that the input current transient does not cause drop below VIN UVLO level. If the input supply is connected with long wires, additional bulk capacitance may be required in addition to normal input capacitor.

The voltage range for V<sub>DD</sub> is 3 V to 5.5 V. A ceramic capacitor must be placed as close as possible to the VDD pin. The boost gate driver is powered from the CPUMP pins. A ceramic capacitor must be placed as close to the CPUMP pins as possible.

## 10 Layout

### 10.1 Layout Guidelines

Figure 10-1 shows a layout recommendation for the LP8864S-Q1 used to illustrate the principles of good layout. This layout can be adapted to the actual application layout if and where possible. It is important that all boost components are close to each other and to the chip; the high-current traces must be wide enough. VDD must be as noise-free as possible. Place a  $V_{DD}$  bypass capacitor near the VDD and GND pins. A charge-pump capacitor, boost input capacitors, and boost output capacitors must have closest VIAs to GND. Place the charge-pump capacitors close to the device. The main points to guide the PCB layout design:

- Current loops need to be minimized:
  - For low frequency the minimal current loop can be achieved by placing the boost components as close as possible to each other. Input and output capacitor grounds need to be close to each other to minimize current loop size.
  - Minimal current loops for high frequencies can be achieved by making sure that the ground plane is intact under the current traces. High frequency return currents follow the route with minimum impedance, which is the route with minimum loop area, not necessarily the shortest path. Minimum loop area is formed when return current flows just under the *positive* current route in the ground plane, if the ground plane is intact under the route.
  - For high frequency the copper area capacitance must be taken into account. For example, the copper area for the drain of boost N-MOSFET is a tradeoff between capacitance and the cooling capacity of the components.
- GND plane must be intact under the high-current-boost traces to provide shortest possible return path and smallest possible current loops for high frequencies.
- Route boost output voltage ( $V_{OUT}$ ) to LEDs, FB pin & Discharge pin after output capacitors not straight from the diode cathode.
- FB network should be placed as close as possible to the FB pin, not near boost output
- A small bypass capacitor (TI recommends a 39-pF capacitor) could be placed close to the FB pin and GND to suppress high frequency noise
- VDD line must be separated from the high current supply path to the boost converter to prevent high frequency ripple affecting the chip behavior.
- Capacitor connected to charge pump output CPUMP is recommended to have 10- $\mu$ F capacitance. This capacitor must be as close as possible to CPUMP pin. This capacitor provides a greater peak current for gate driver and must be used even if the charge pump is disabled. If the charge pump is disabled, the VDD and CPUMP pins must be tied together.
- Input and output capacitors need low-impedance grounding (wide traces with many vias to GND plane).
- Input/output ceramic capacitors have DC-bias effect. If the output capacitance is too low, it can cause boost to become unstable under certain load conditions. DC bias characteristics should be obtained from the component manufacturer; DC bias is not taken into account on component tolerance.

## 10.2 Layout Example

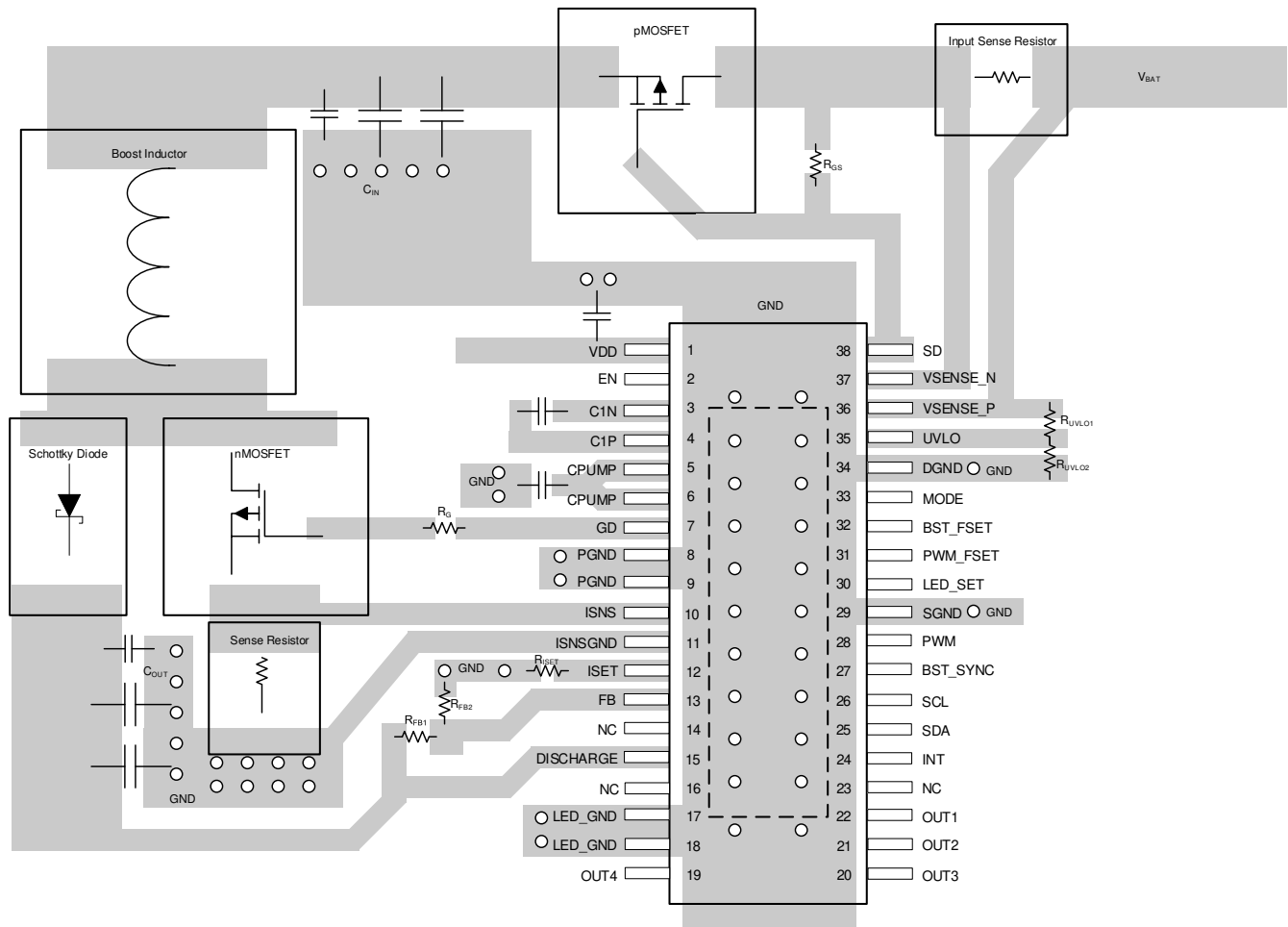

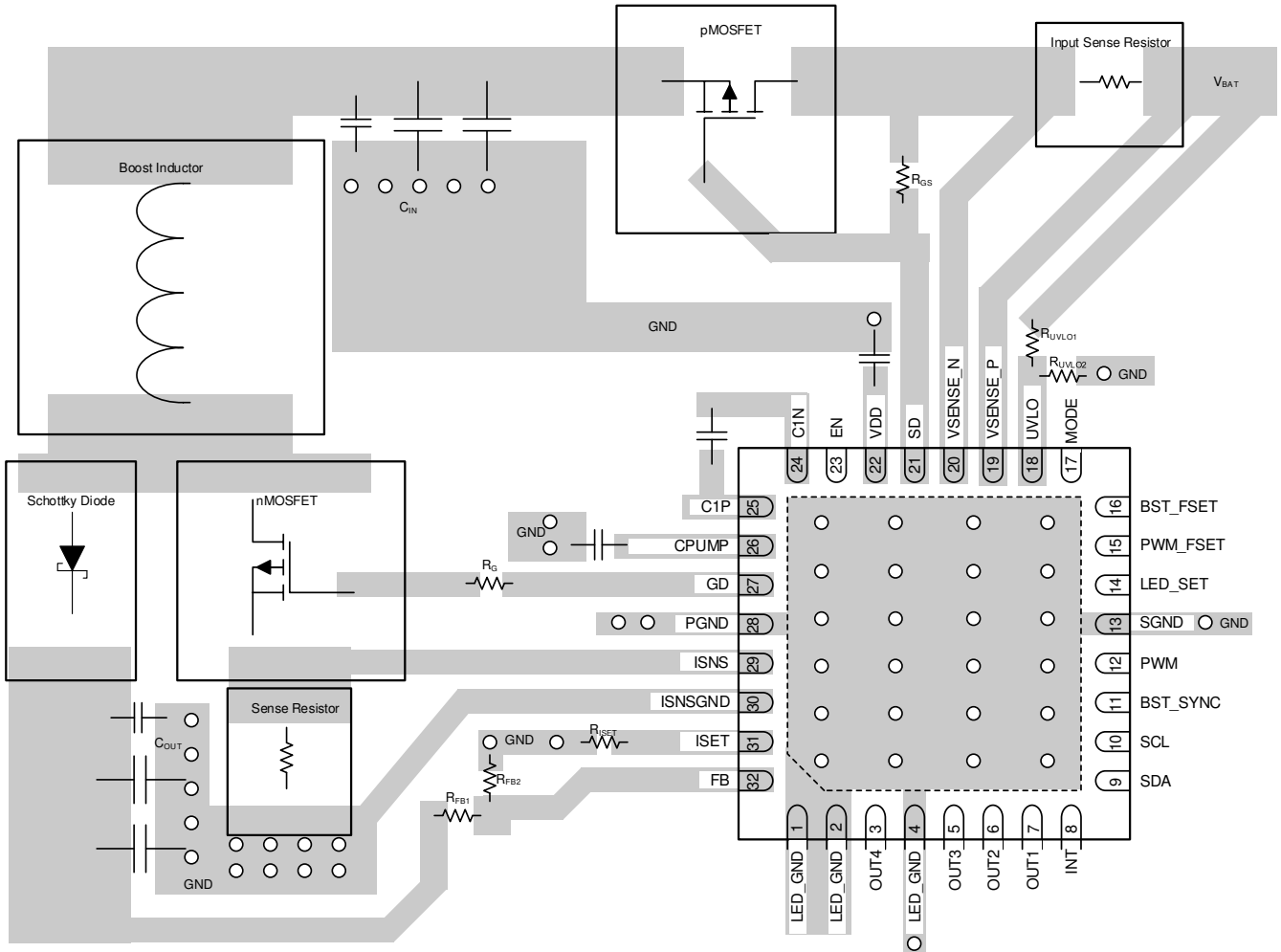

**图 10-1. LP8864S-Q1 Layout Guidelines**

## 11 Device and Documentation Support

### 11.1 Device Support

#### 11.1.1 第三方产品免责声明

TI 发布的与第三方产品或服务有关的信息，不能构成与此类产品或服务或保修的适用性有关的认可，不能构成此类产品或服务单独或与任何 TI 产品或服务一起的表示或认可。

#### 11.2 接收文档更新通知

要接收文档更新通知，请导航至 [ti.com](http://ti.com) 上的器件产品文件夹。点击 [订阅更新](#) 进行注册，即可每周接收产品信息更改摘要。有关更改的详细信息，请查看任何已修订文档中包含的修订历史记录。

#### 11.3 支持资源

TI E2E™ [支持论坛](#) 是工程师的重要参考资料，可直接从专家获得快速、经过验证的解答和设计帮助。搜索现有解答或提出自己的问题可获得所需的快速设计帮助。

链接的内容由各个贡献者“按原样”提供。这些内容并不构成 TI 技术规范，并且不一定反映 TI 的观点；请参阅 TI 的 [《使用条款》](#)。

#### 11.4 Trademarks

TI E2E™ is a trademark of Texas Instruments.

所有商标均为其各自所有者的财产。

#### 11.5 静电放电警告



静电放电 (ESD) 会损坏这个集成电路。德州仪器 (TI) 建议通过适当的预防措施处理所有集成电路。如果不遵守正确的处理和安装程序，可能会损坏集成电路。

ESD 的损坏小至导致微小的性能降级，大至整个器件故障。精密的集成电路可能更容易受到损坏，这是因为非常细微的参数更改都可能会导致器件与其发布的规格不相符。

#### 11.6 术语表

[TI 术语表](#) 本术语表列出并解释了术语、首字母缩略词和定义。

## 12 Mechanical, Packaging, and Orderable Information

The following pages include mechanical, packaging, and orderable information. This information is the most current data available for the designated devices. This data is subject to change without notice and revision of this document. For browser-based versions of this data sheet, refer to the left-hand navigation.

**PACKAGING INFORMATION**

Orderable Device	Status (1)	Package Type	Package Drawing	Pins	Package Qty	Eco Plan (2)	Lead finish/ Ball material (6)	MSL Peak Temp (3)	Op Temp (°C)	Device Marking (4/5)	Samples
LP8864SQDCPRQ1	ACTIVE	HTSSOP	DCP	38	2000	RoHS & Green	NIPDAU	Level-3-260C-168 HR	-40 to 125	LP8864SQ1	<a href="#">Samples</a>
LP8864SQRHBRQ1	ACTIVE	VQFN	RHB	32	3000	RoHS & Green	NIPDAU	Level-2-260C-1 YEAR	-40 to 125	LP8864S	<a href="#">Samples</a>

(1) The marketing status values are defined as follows:

**ACTIVE:** Product device recommended for new designs.

**LIFEBUY:** TI has announced that the device will be discontinued, and a lifetime-buy period is in effect.

**NRND:** Not recommended for new designs. Device is in production to support existing customers, but TI does not recommend using this part in a new design.

**PREVIEW:** Device has been announced but is not in production. Samples may or may not be available.

**OBSOLETE:** TI has discontinued the production of the device.

(2) **RoHS:** TI defines "RoHS" to mean semiconductor products that are compliant with the current EU RoHS requirements for all 10 RoHS substances, including the requirement that RoHS substance do not exceed 0.1% by weight in homogeneous materials. Where designed to be soldered at high temperatures, "RoHS" products are suitable for use in specified lead-free processes. TI may reference these types of products as "Pb-Free".

**RoHS Exempt:** TI defines "RoHS Exempt" to mean products that contain lead but are compliant with EU RoHS pursuant to a specific EU RoHS exemption.

**Green:** TI defines "Green" to mean the content of Chlorine (Cl) and Bromine (Br) based flame retardants meet JS709B low halogen requirements of <=1000ppm threshold. Antimony trioxide based flame retardants must also meet the <=1000ppm threshold requirement.

(3) MSL, Peak Temp. - The Moisture Sensitivity Level rating according to the JEDEC industry standard classifications, and peak solder temperature.

(4) There may be additional marking, which relates to the logo, the lot trace code information, or the environmental category on the device.

(5) Multiple Device Markings will be inside parentheses. Only one Device Marking contained in parentheses and separated by a "~" will appear on a device. If a line is indented then it is a continuation of the previous line and the two combined represent the entire Device Marking for that device.

(6) Lead finish/Ball material - Orderable Devices may have multiple material finish options. Finish options are separated by a vertical ruled line. Lead finish/Ball material values may wrap to two lines if the finish value exceeds the maximum column width.

**Important Information and Disclaimer:**The information provided on this page represents TI's knowledge and belief as of the date that it is provided. TI bases its knowledge and belief on information provided by third parties, and makes no representation or warranty as to the accuracy of such information. Efforts are underway to better integrate information from third parties. TI has taken and continues to take reasonable steps to provide representative and accurate information but may not have conducted destructive testing or chemical analysis on incoming materials and chemicals. TI and TI suppliers consider certain information to be proprietary, and thus CAS numbers and other limited information may not be available for release.

In no event shall TI's liability arising out of such information exceed the total purchase price of the TI part(s) at issue in this document sold by TI to Customer on an annual basis.



## TAPE AND REEL INFORMATION

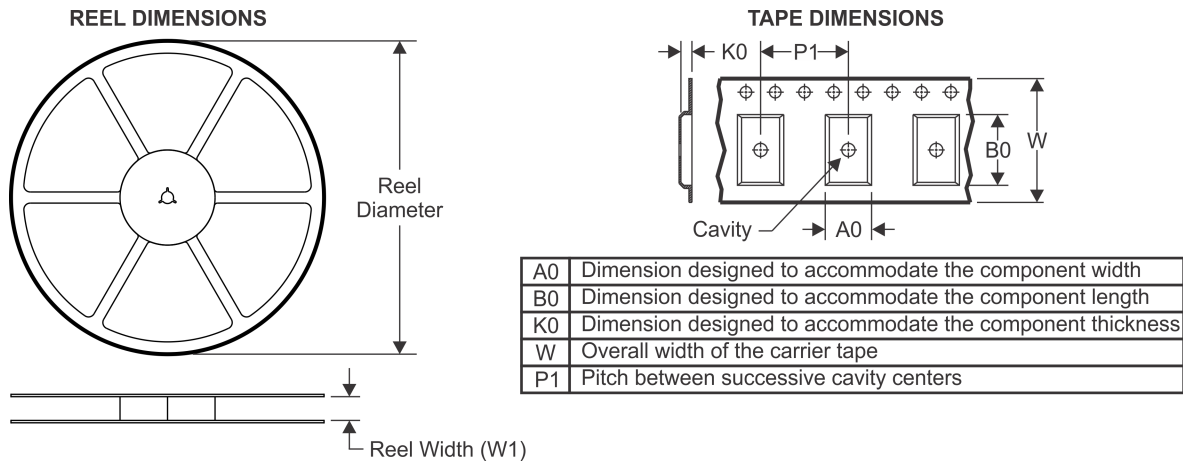

### QUADRANT ASSIGNMENTS FOR PIN 1 ORIENTATION IN TAPE

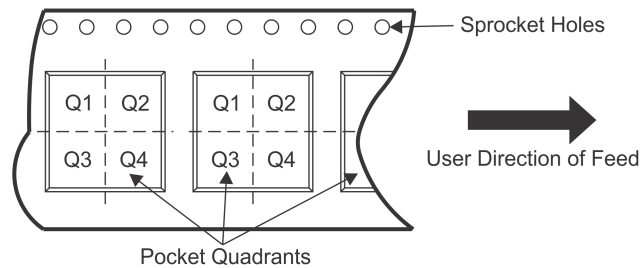

\*All dimensions are nominal

Device	Package Type	Package Drawing	Pins	SPQ	Reel Diameter (mm)	Reel Width W1 (mm)	A0 (mm)	B0 (mm)	K0 (mm)	P1 (mm)	W (mm)	Pin1 Quadrant
LP8864SQDCPRQ1	HTSSOP	DCP	38	2000	330.0	16.4	6.9	10.2	1.8	12.0	16.0	Q1
LP8864SQRHBRQ1	VQFN	RHB	32	3000	330.0	12.4	5.3	5.3	1.1	8.0	12.0	Q2

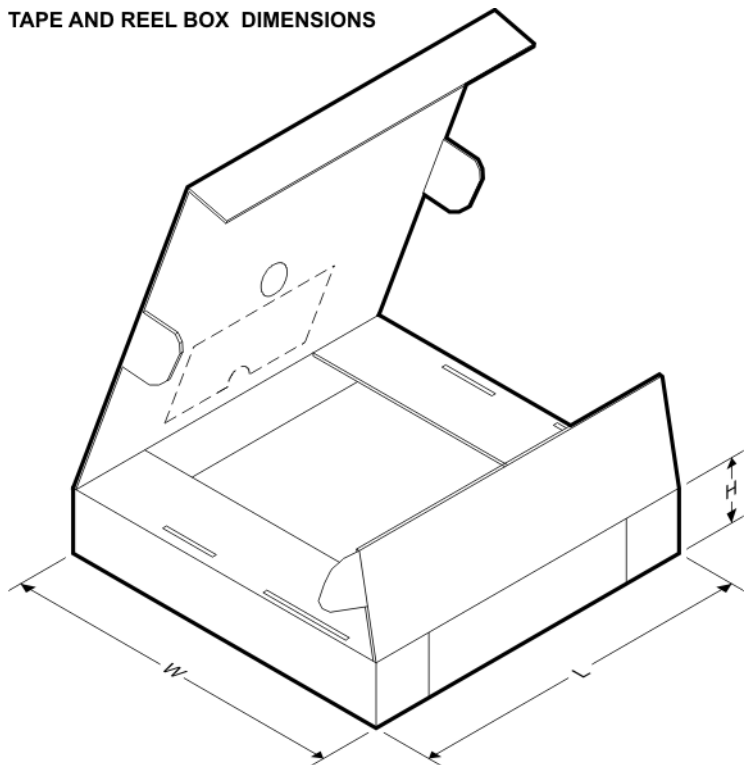
**TAPE AND REEL BOX DIMENSIONS**

\*All dimensions are nominal

Device	Package Type	Package Drawing	Pins	SPQ	Length (mm)	Width (mm)	Height (mm)
LP8864SQDCPRQ1	HTSSOP	DCP	38	2000	350.0	350.0	43.0
LP8864SQRHBRQ1	VQFN	RHB	32	3000	367.0	367.0	35.0

## GENERIC PACKAGE VIEW

**DCP 38**

**PowerPAD TSSOP - 1.2 mm max height**

4.4 x 9.7, 0.5 mm pitch

SMALL OUTLINE PACKAGE

This image is a representation of the package family, actual package may vary.  
Refer to the product data sheet for package details.

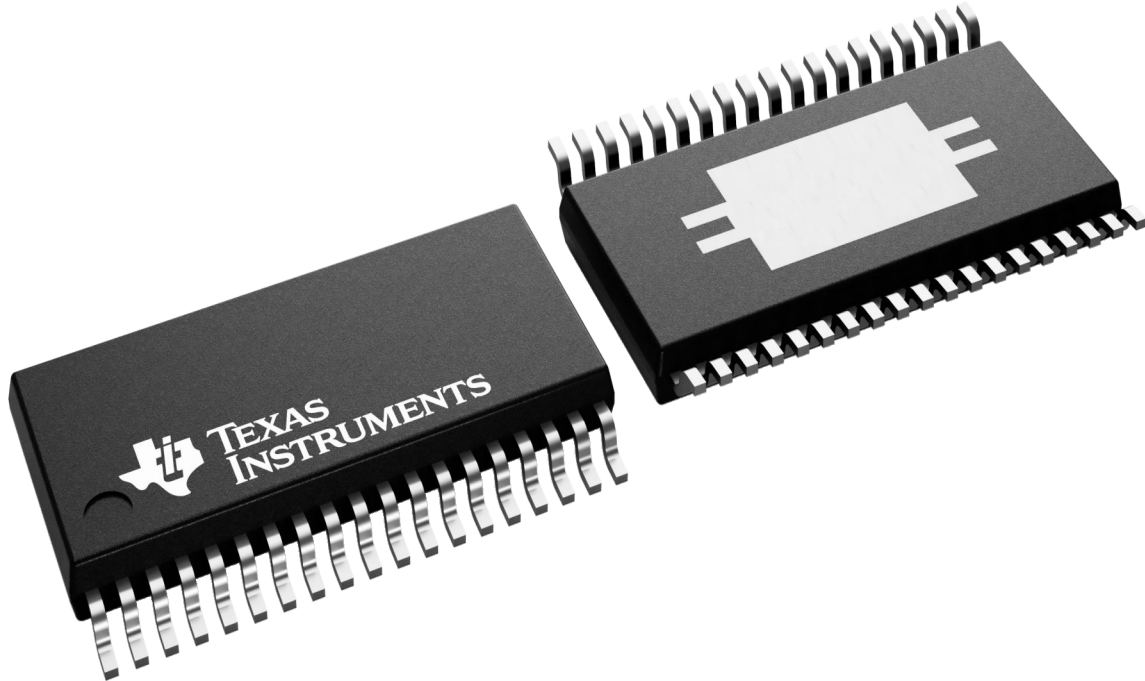

4224560/B

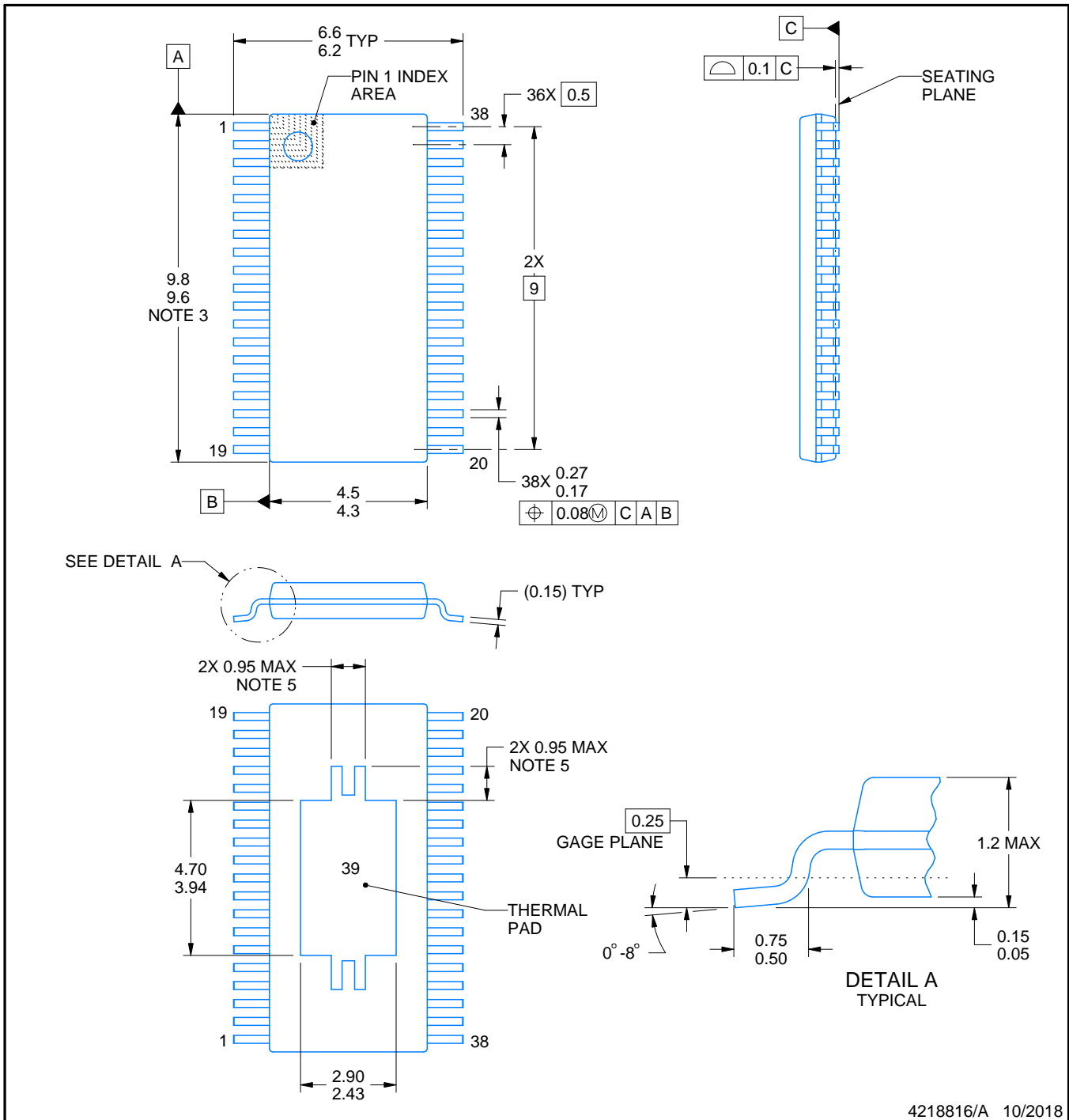
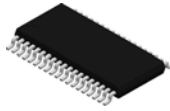

4218816/A 10/2018

NOTES:

PowerPAD is a trademark of Texas Instruments.

1. All linear dimensions are in millimeters. Any dimensions in parenthesis are for reference only. Dimensioning and tolerancing per ASME Y14.5M.
2. This drawing is subject to change without notice.
3. This dimension does not include mold flash, protrusions, or gate burrs. Mold flash, protrusions, or gate burrs shall not exceed 0.15 mm per side.
4. Reference JEDEC registration MO-153.
5. Features may differ or may not be present.

# EXAMPLE BOARD LAYOUT

DCP0038A

PowerPAD™ TSSOP - 1.2 mm max height

SMALL OUTLINE PACKAGE

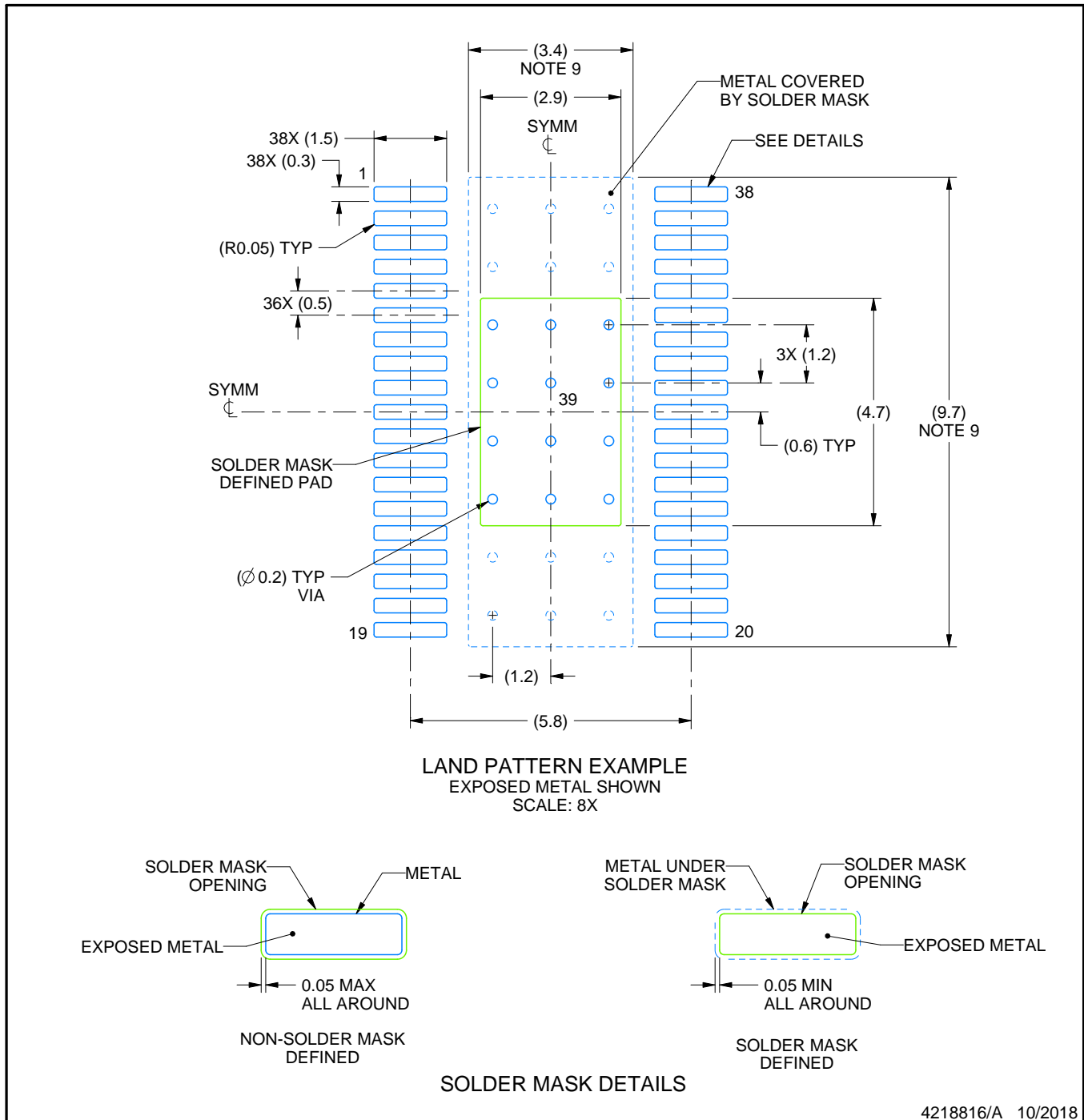

4218816/A 10/2018

NOTES: (continued)

- Publication IPC-7351 may have alternate designs.
- Solder mask tolerances between and around signal pads can vary based on board fabrication site.
- This package is designed to be soldered to a thermal pad on the board. For more information, see Texas Instruments literature numbers SLMA002 ([www.ti.com/lit/slma002](http://www.ti.com/lit/slma002)) and SLMA004 ([www.ti.com/lit/slma004](http://www.ti.com/lit/slma004)).
- Size of metal pad may vary due to creepage requirement.
- Vias are optional depending on application, refer to device data sheet. It is recommended that vias under paste be filled, plugged or tented.

# EXAMPLE STENCIL DESIGN

DCP0038A

PowerPAD™ TSSOP - 1.2 mm max height

SMALL OUTLINE PACKAGE

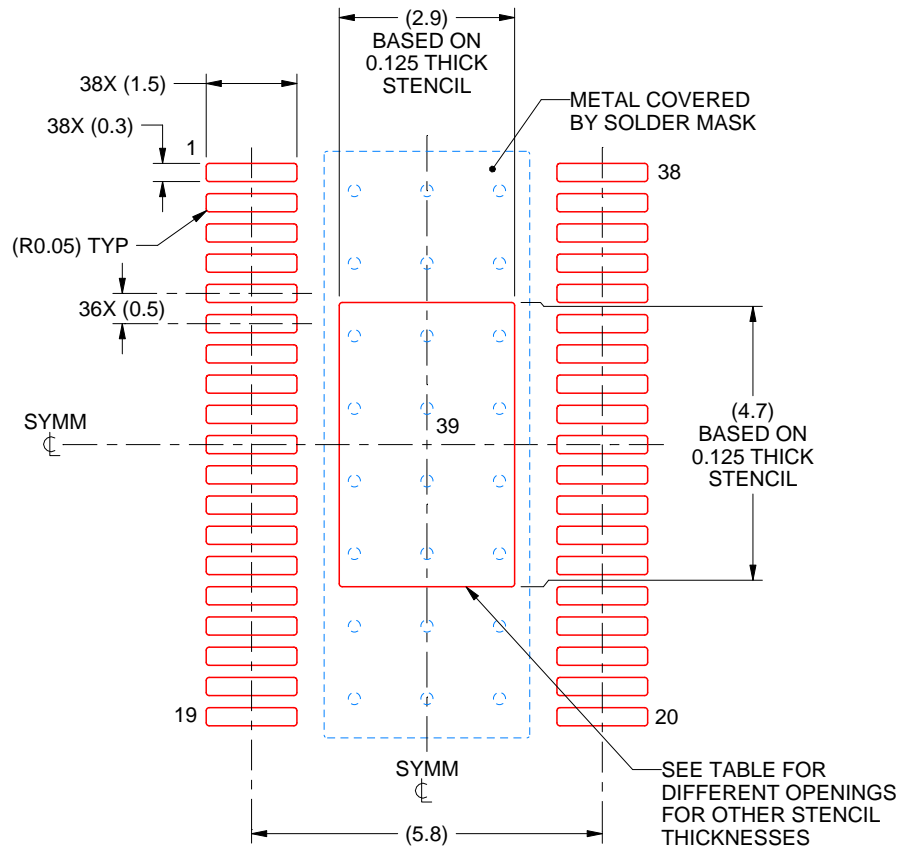

**SOLDER PASTE EXAMPLE**  
 BASED ON 0.125 mm THICK STENCIL  
 SCALE: 8X

STENCIL THICKNESS	SOLDER STENCIL OPENING
0.1	3.24 X 5.25
0.125	2.90 X 4.70 (SHOWN)
0.15	2.65 X 4.29
0.175	2.45 X 3.97

4218816/A 10/2018

NOTES: (continued)

11. Laser cutting apertures with trapezoidal walls and rounded corners may offer better paste release. IPC-7525 may have alternate design recommendations.
12. Board assembly site may have different recommendations for stencil design.

## GENERIC PACKAGE VIEW

**RHB 32**

**VQFN - 1 mm max height**

5 x 5, 0.5 mm pitch

PLASTIC QUAD FLATPACK - NO LEAD

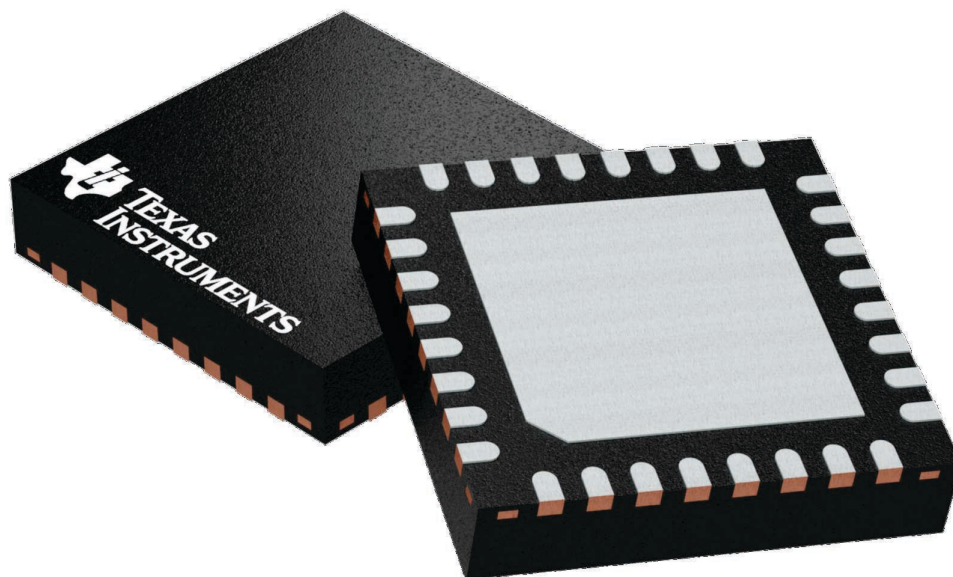

Images above are just a representation of the package family, actual package may vary.  
Refer to the product data sheet for package details.

4224745/A

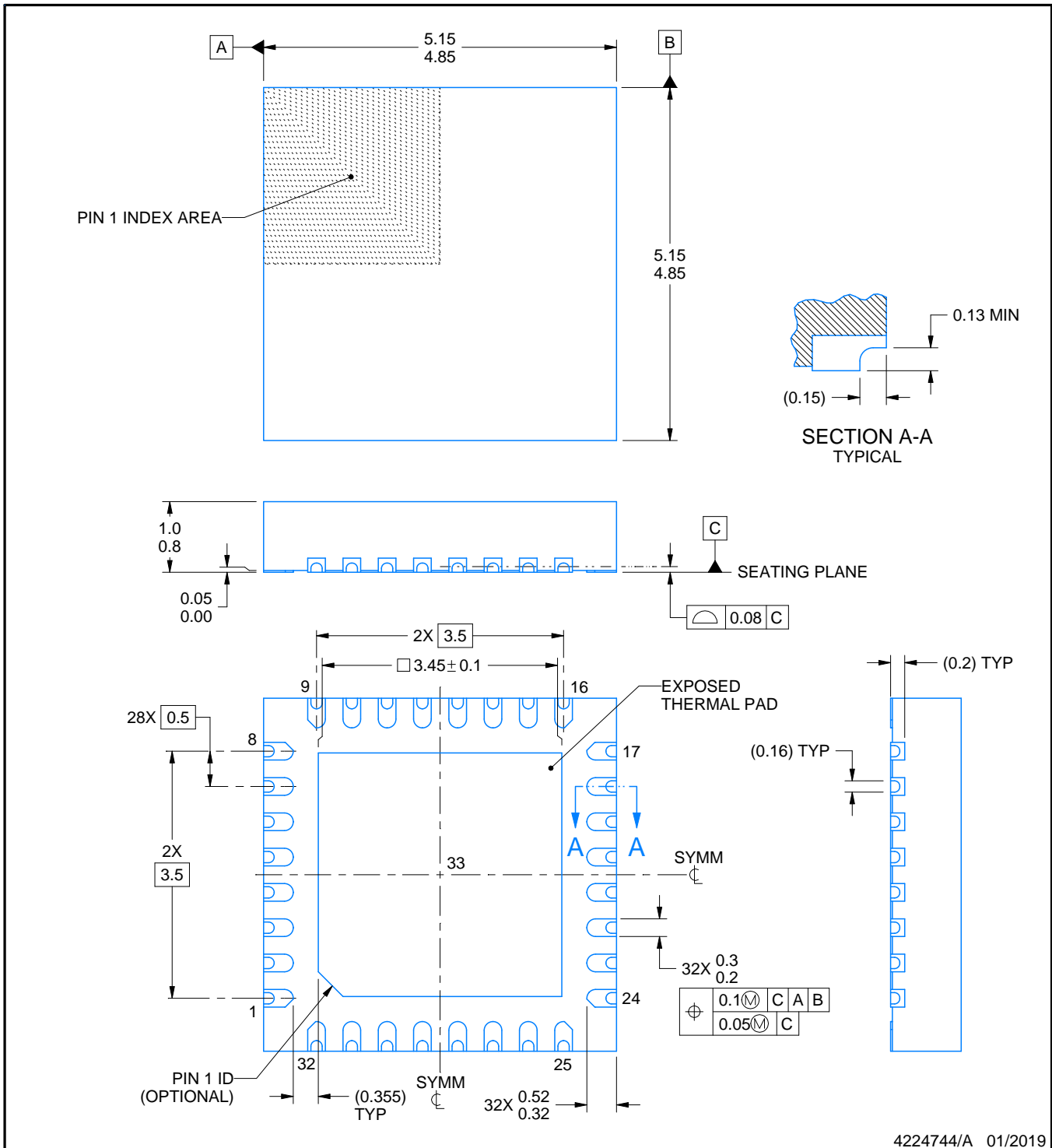
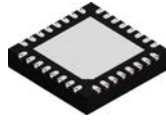

4224744/A 01/2019

NOTES:

1. All linear dimensions are in millimeters. Any dimensions in parenthesis are for reference only. Dimensioning and tolerancing per ASME Y14.5M.
2. This drawing is subject to change without notice.
3. The package thermal pad must be soldered to the printed circuit board for thermal and mechanical performance.

# EXAMPLE BOARD LAYOUT

RHB0032T

VQFN - 1 mm max height

PLASTIC QUAD FLATPACK - NO LEAD

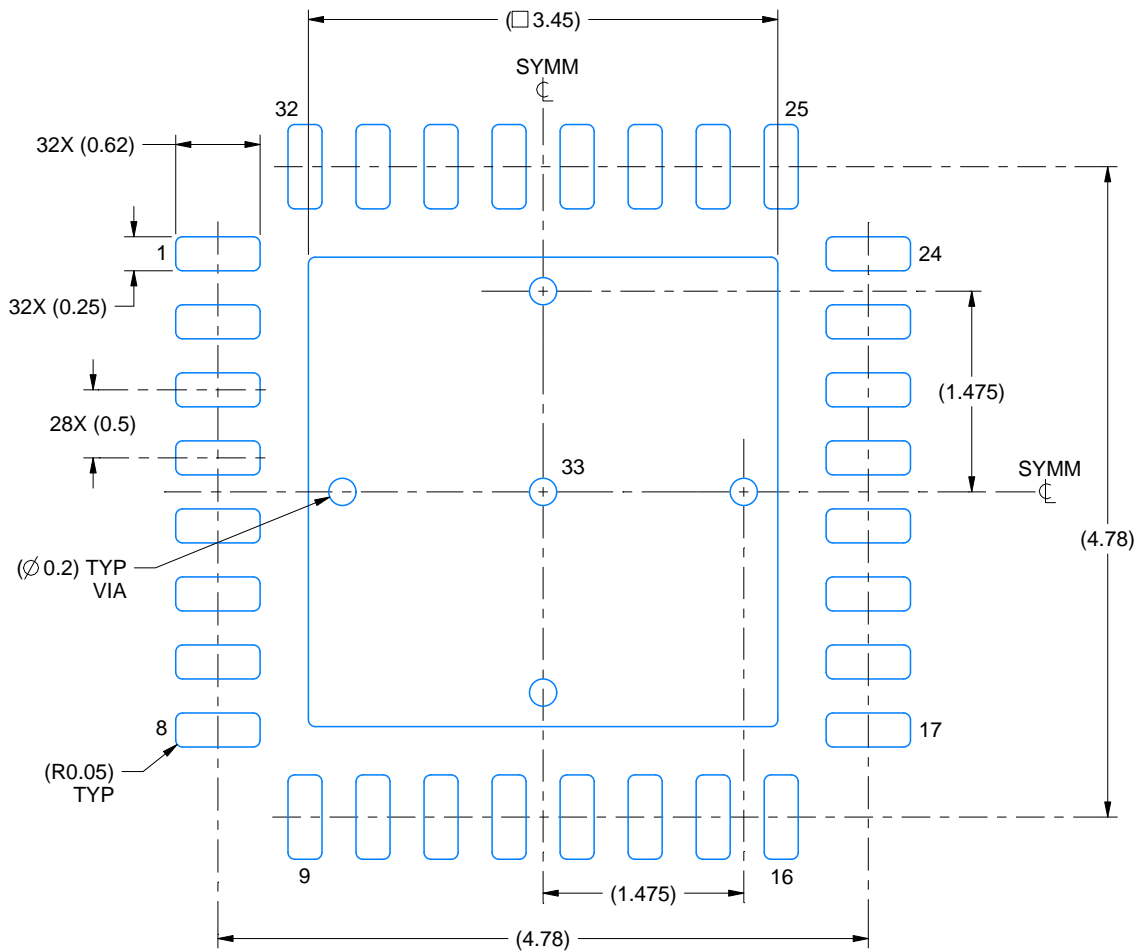

LAND PATTERN EXAMPLE  
EXPOSED METAL SHOWN  
SCALE:18X

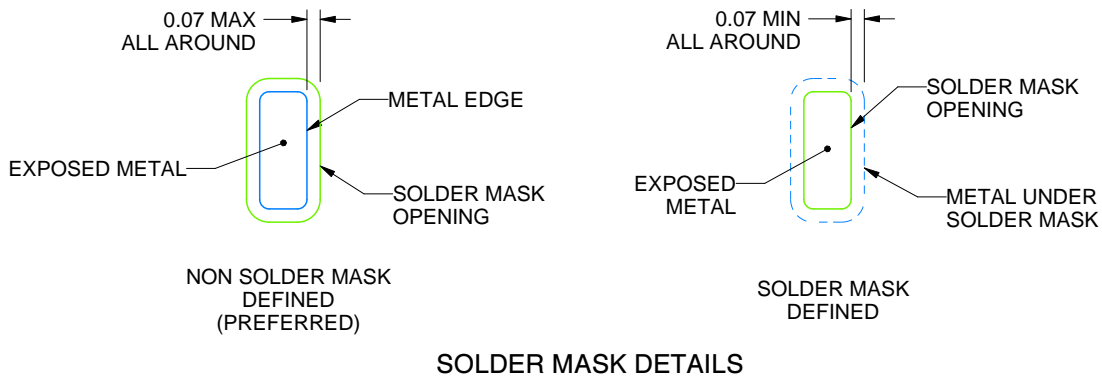

SOLDER MASK DETAILS

4224744/A 01/2019

NOTES: (continued)

- This package is designed to be soldered to a thermal pad on the board. For more information, see Texas Instruments literature number SLUA271 ([www.ti.com/lit/slua271](http://www.ti.com/lit/slua271)).
- Vias are optional depending on application, refer to device data sheet. If any vias are implemented, refer to their locations shown on this view. It is recommended that vias under paste be filled, plugged or tented.

# EXAMPLE STENCIL DESIGN

RHB0032T

VQFN - 1 mm max height

PLASTIC QUAD FLATPACK - NO LEAD

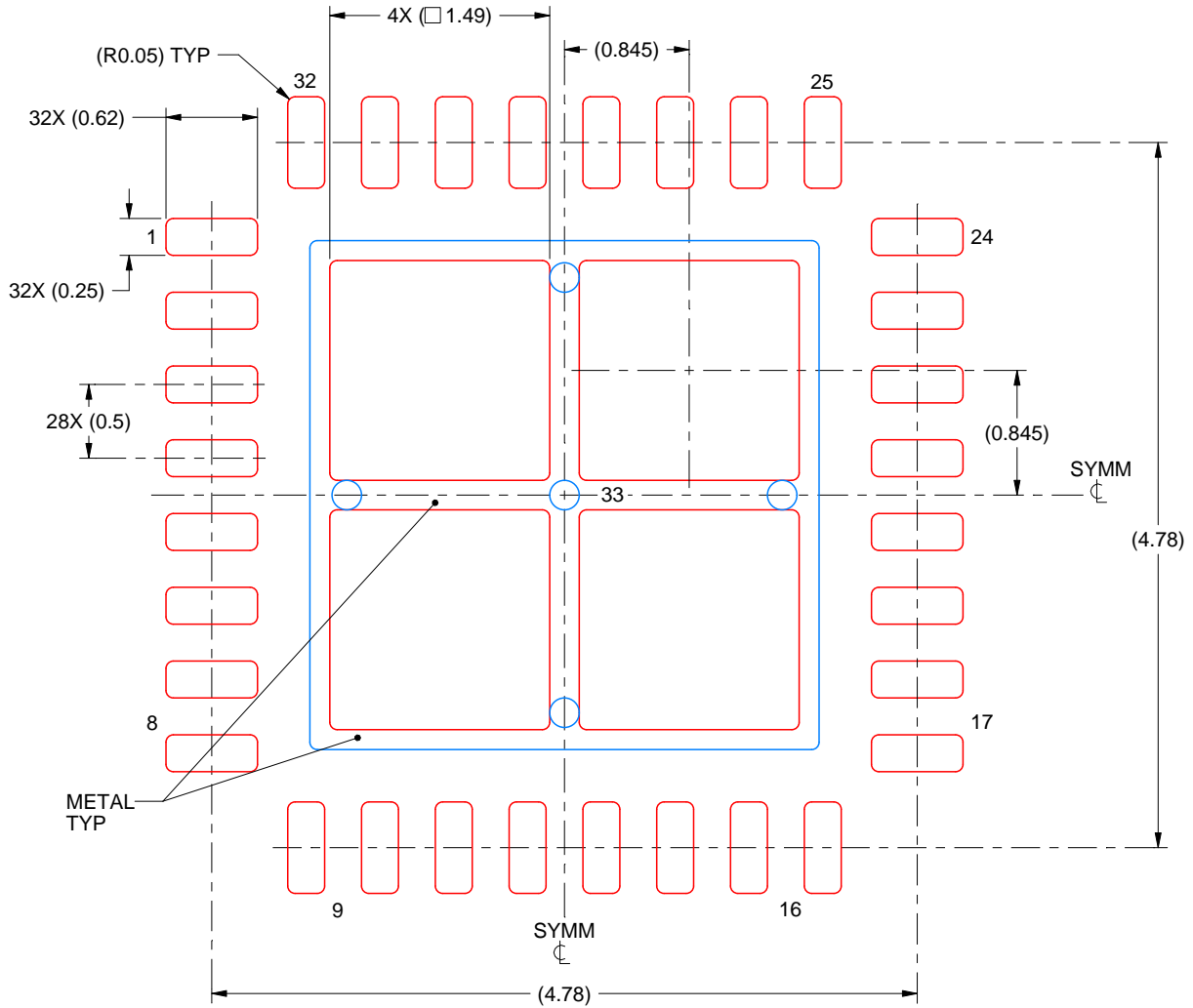

**SOLDER PASTE EXAMPLE**  
 BASED ON 0.125 mm THICK STENCIL

EXPOSED PAD 33:  
 75% PRINTED SOLDER COVERAGE BY AREA UNDER PACKAGE  
 SCALE:20X

4224744/A 01/2019

NOTES: (continued)

6. Laser cutting apertures with trapezoidal walls and rounded corners may offer better paste release. IPC-7525 may have alternate design recommendations.

## 重要声明和免责声明

TI“按原样”提供技术和可靠性数据（包括数据表）、设计资源（包括参考设计）、应用或其他设计建议、网络工具、安全信息和其他资源，不保证没有瑕疵且不做任何明示或暗示的担保，包括但不限于对适销性、某特定用途方面的适用性或不侵犯任何第三方知识产权的暗示担保。

这些资源可供使用 TI 产品进行设计的熟练开发人员使用。您将自行承担以下全部责任：(1) 针对您的应用选择合适的 TI 产品，(2) 设计、验证并测试您的应用，(3) 确保您的应用满足相应标准以及任何其他功能安全、信息安全、监管或其他要求。

这些资源如有变更，恕不另行通知。TI 授权您仅可将这些资源用于研发本资源所述的 TI 产品的应用。严禁对这些资源进行其他复制或展示。您无权使用任何其他 TI 知识产权或任何第三方知识产权。您应全额赔偿因在这些资源的使用中对 TI 及其代表造成的任何索赔、损害、成本、损失和债务，TI 对此概不负责。

TI 提供的产品受 [TI 的销售条款](#) 或 [ti.com](#) 上其他适用条款/TI 产品随附的其他适用条款的约束。TI 提供这些资源并不会扩展或以其他方式更改 TI 针对 TI 产品发布的适用的担保或担保免责声明。

TI 反对并拒绝您可能提出的任何其他或不同的条款。

邮寄地址：Texas Instruments, Post Office Box 655303, Dallas, Texas 75265  
Copyright © 2021，德州仪器 (TI) 公司