

MSP430FR599x, MSP430FR596x Mixed-Signal Microcontrollers

1 Features

- Embedded microcontroller
 - 16-bit RISC architecture up to 16-MHz clock
 - Up to 256KB of ferroelectric random access memory (FRAM)
 - Ultra-low-power writes
 - Fast write at 125 ns per word (64KB in 4 ms)
 - Flexible allocation of data and application code in memory
 - 10¹⁵ write cycle endurance
 - Radiation resistant and nonmagnetic
 - Wide supply voltage range from 3.6 V down to 1.8 V (minimum supply voltage is restricted by SVS levels, see the [SVS specifications](#))
- Optimized ultra-low-power modes
 - Active mode: 118 µA/MHz
 - Standby with VLO (LPM3): 500 nA
 - Standby with real-time clock (RTC) (LPM3.5): 350 nA (the RTC is clocked by a 3.7-pF crystal)
 - Shutdown (LPM4.5): 45 nA
- Low-energy accelerator (LEA) for signal processing (MSP430FR599x only)
 - Operation independent of CPU
 - 4KB of RAM shared with CPU
 - Efficient 256-point complex FFT: Up to 40x faster than Arm® Cortex®-M0+ core
- Intelligent digital peripherals
 - 32-bit hardware multiplier (MPY)
 - 6-channel internal DMA
 - RTC with calendar and alarm functions
 - Six 16-bit timers with up to seven capture/compare registers each
 - 32- and 16-bit cyclic redundancy check (CRC)
- High-performance analog
 - 16-channel analog comparator
 - 12-bit analog-to-digital converter (ADC) featuring window comparator, internal reference and sample-and-hold, up to 20 external input channels
- Multifunction input/output ports
 - All pins support capacitive-touch capability with no need for external components
 - Accessible bit-, byte-, and word-wise (in pairs)
 - Edge-selectable wake from LPM on all ports
 - Programmable pullup and pulldown on all ports
- Code security and encryption
 - 128- or 256-bit AES security encryption and decryption coprocessor
 - Random number seed for random number generation algorithms
 - IP encapsulation protects memory from external access
- Enhanced serial communication
 - Up to four eUSCI_A serial communication ports
 - UART with automatic baud-rate detection
 - IrDA encode and decode
 - Up to four eUSCI_B serial communication ports
 - I²C with multiple-slave addressing
 - Hardware UART or I²C bootloader (BSL)
- Flexible clock system
 - Fixed-frequency DCO with 10 selectable factory-trimmed frequencies
 - Low-power low-frequency internal clock source (VLO)
 - 32-kHz crystals (LFXT)
 - High-frequency crystals (HFXT)
- Development tools and software (also see [Tools and Software](#))
 - Development kits ([MSP-EXP430FR5994](#) LaunchPad™ development kit and [MSP-TS430PN80B](#) target socket board)
 - [MSP430Ware™](#) software for MSP430™ microcontrollers
- [Device Comparison](#) summarizes the available devices

2 Applications

- [Grid infrastructure](#)
- [Factory automation & control](#)
- [Building automation](#)
- [Wearable fitness & activity monitor](#)
- [Wearable electronics](#)



3 Description

The MSP430FR599x microcontrollers (MCUs) take low power and performance to the next level with the unique low-energy accelerator (LEA) for digital signal processing. This accelerator delivers 40x the performance of Arm® Cortex®-M0+ MCUs to help developers efficiently process data using complex functions such as FFT, FIR, and matrix multiplication. Implementation requires no DSP expertise with a free optimized DSP Library available. Additionally, with up to 256KB of unified memory with FRAM, these devices offer more space for advanced applications and flexibility for effortless implementation of over-the-air firmware updates.

The MSP ultra-low-power (ULP) FRAM microcontroller platform combines uniquely embedded FRAM and a holistic ultra-low-power system architecture, allowing system designers to increase performance while lowering energy consumption. FRAM technology combines the low-energy fast writes, flexibility, and endurance of RAM with the nonvolatile behavior of flash.

MSP430FR599x MCUs are supported by an extensive hardware and software ecosystem with reference designs and code examples to get your design started quickly. Development kits for the MSP430FR599x include the [MSP-EXP430FR5994 LaunchPad™ development kit](#) and the [MSP-TS430PN80B 80-pin target development board](#). TI also provides free [MSP430Ware™ software](#), which is available as a component of Code Composer Studio™ IDE desktop and cloud versions within TI Resource Explorer.

For complete module descriptions, see the [MSP430FR58xx](#), [MSP430FR59xx](#), and [MSP430FR6xx Family User's Guide](#).

Device Information

PART NUMBER ^{(1) (2)}	PACKAGE	BODY SIZE ⁽³⁾
MSP430FR5994IZVW	NFBGA (87)	6 mm × 6 mm
MSP430FR5994IPN	LQFP (80)	12 mm × 12 mm
MSP430FR5994IPM	LQFP (64)	10 mm × 10 mm
MSP430FR5994IRGZ	VQFN (48)	7 mm × 7 mm

- (1) For the most current part, package, and ordering information for all available devices, see the *Package Option Addendum* in [Section 12](#), or see the TI website at www.ti.com.
- (2) For a comparison of all available device variants, see [Section 6](#).
- (3) The sizes shown here are approximations. For the package dimensions with tolerances, see the *Mechanical Data* in [Section 12](#).

4 Functional Block Diagram

Figure 4-1 shows the functional block diagram of the devices.

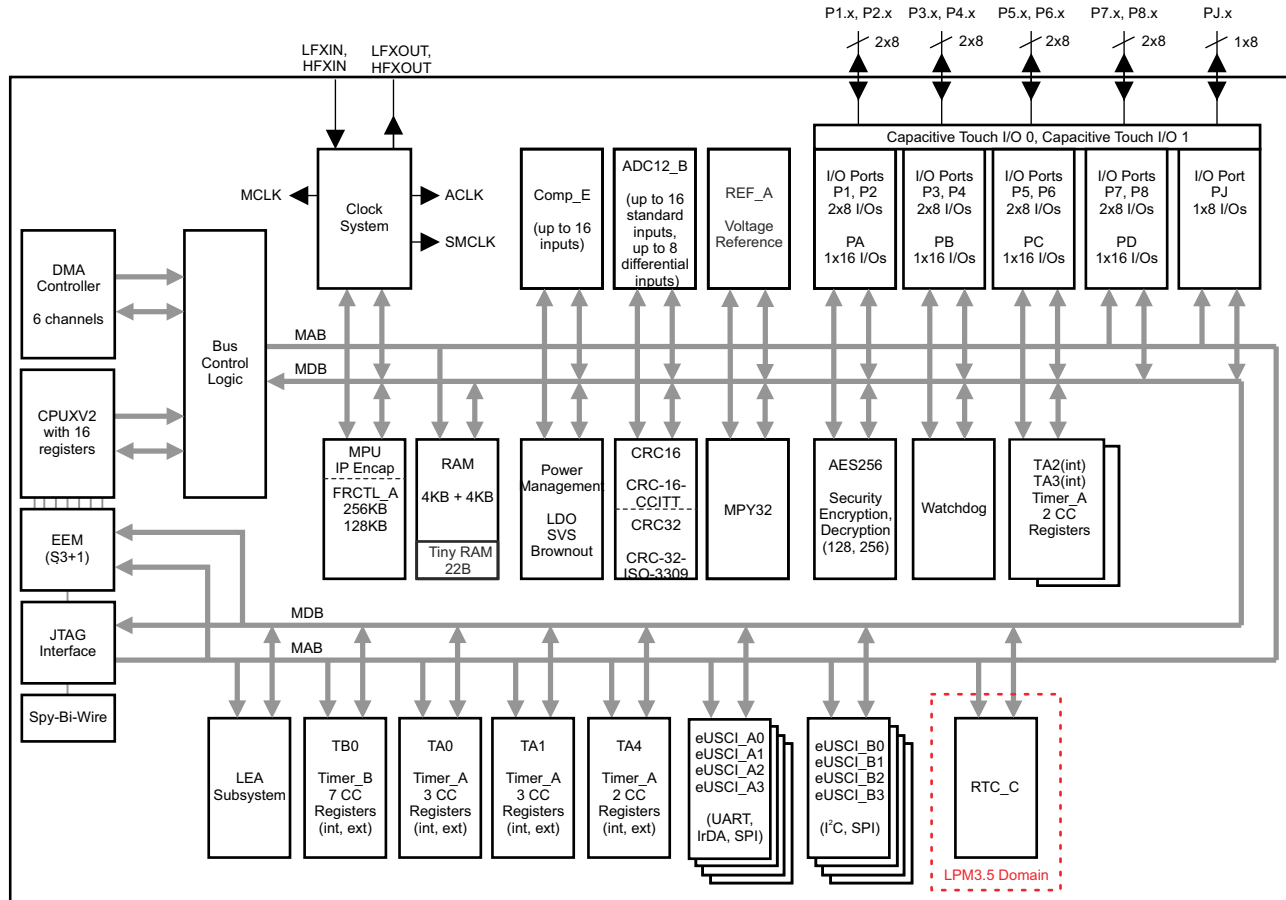

- A. The device has 8KB of RAM, and 4KB of the RAM is shared with the LEA subsystem. The CPU has priority over the LEA subsystem.
- B. The LEA subsystem is available on the MSP430FR599x MCUs only.

Figure 4-1. Functional Block Diagram

Table of Contents

1 Features	1	9.1 Overview.....	66
2 Applications	1	9.2 CPU.....	66
3 Description	2	9.3 Low-Energy Accelerator (LEA) for Signal Processing (MSP430FR599x Only).....	66
4 Functional Block Diagram	3	9.4 Operating Modes.....	67
5 Revision History	5	9.5 Interrupt Vector Table and Signatures.....	70
6 Device Comparison	7	9.6 Bootloader (BSL).....	73
6.1 Related Products.....	8	9.7 JTAG Operation.....	74
7 Terminal Configuration and Functions	9	9.8 FRAM Controller A (FRCTL_A).....	75
7.1 Pin Diagrams.....	9	9.9 RAM.....	75
7.2 Pin Attributes.....	14	9.10 Tiny RAM.....	75
7.3 Signal Descriptions.....	20	9.11 Memory Protection Unit (MPU) Including IP Encapsulation.....	75
7.4 Pin Multiplexing.....	28	9.12 Peripherals.....	76
7.5 Buffer Types.....	28	9.13 Input/Output Diagrams.....	86
7.6 Connection of Unused Pins.....	28	9.14 Device Descriptors (TLV).....	124
8 Specifications	29	9.15 Memory Map.....	127
8.1 Absolute Maximum Ratings.....	29	9.16 Identification.....	147
8.2 ESD Ratings.....	29	10 Applications, Implementation, and Layout	148
8.3 Recommended Operating Conditions.....	30	10.1 Device Connection and Layout Fundamentals.....	148
8.4 Active Mode Supply Current Into V_{CC} Excluding External Current.....	31	10.2 Peripheral- and Interface-Specific Design Information.....	151
8.5 Typical Characteristics, Active Mode Supply Currents.....	32	11 Device and Documentation Support	153
8.6 Low-Power Mode (LPM0, LPM1) Supply Currents Into V_{CC} Excluding External Current.....	32	11.1 Getting Started.....	153
8.7 Low-Power Mode (LPM2, LPM3, LPM4) Supply Currents (Into V_{CC}) Excluding External Current.....	33	11.2 Device Nomenclature.....	153
8.8 Low-Power Mode (LPMx.5) Supply Currents (Into V_{CC}) Excluding External Current.....	35	11.3 Tools and Software.....	154
8.9 Typical Characteristics, Low-Power Mode Supply Currents.....	36	11.4 Documentation Support.....	156
8.10 Typical Characteristics, Current Consumption per Module.....	37	11.5 Related Links.....	157
8.11 Thermal Packaging Characteristics.....	37	11.6 Support Resources.....	157
8.12 Timing and Switching Characteristics.....	38	11.7 Trademarks.....	157
9 Detailed Description	66	11.8 Electrostatic Discharge Caution.....	158
		11.9 Export Control Notice.....	158
		11.10 Glossary.....	158
		12 Mechanical, Packaging, and Orderable Information	159

5 Revision History

NOTE: Page numbers for previous revisions may differ from page numbers in the current version.

Changes from revision C to revision D

Changes from August 31, 2018 to January 15, 2021	Page
• Updated the numbering format for tables, figures, and cross references throughout the document.....	1
• Format updates and corrections to external links as needed.....	1
• Changed the column "FRAM Program + Information (KB)" in Section 6, Device Comparison	7
• Added ball L5 to the COUT signal on the ZVW package in Section 7.3, Signal Descriptions	20
• Added the note that begins "XT1CLK and VLOCLK can be active during LPM4..."	67
• Added the INTERRUPT VECTOR REGISTER column, moved register names from the INTERRUPT FLAG column, and corrected interrupt flag names as necessary in Table 9-4, Interrupt Sources, Flags, Vectors, and Signatures	70
• Corrected the interrupt flags for Port 4 to Port 8 in Table 9-4, Interrupt Sources, Flags, and Vectors	70
• Corrected the note on the P1DIR.x column for the UCB0SOMI/UCB0SCL row (changed eUSCI_A0 to eUSCI_B0) in Table 9-22, Port P1 (P1.6 and P1.7) Pin Functions	91
• Corrected the value of P5SEL1.5 (changed from 0 to 1) and P5SEL0.5 (from 1 to 0) for the N/A and DVSS rows on P5.5 in Table 9-31, Port P5 (P5.0 to P5.7) Pin Functions	106
• Corrected eUSCI module in the note "Direction controlled by eUSCI_B1 module" (changed from eUSCI_B0 to eUSCI_B1)	106

Changes from revision B to revision C

Changes from February 1, 2017 to August 30, 2018	Page
• Updated Section 6.1, Related Products	8
• Added note (1) to Section 8.12.1.2, SVS	38
• Corrected the value of P6SEL1.x (changed from 0 to 1) for the N/A and DVSS rows on P6.5, P6.6, and P6.7 in Table 9-32, Port P6 (P6.0 to P6.7) Pin Functions	108
• Changed capacitor value from 4.7 μ F to 470 nF in Figure 10-5, ADC12_B Grounding and Noise Considerations	151
• Changed capacitor value from 4.7 μ F to 470 nF in the last paragraph of Section 10.2.1.2, Design Requirements	151
• Updated text and figure in Section 11.2, Device Nomenclature	153

Changes from revision A to revision B

Changes from October 18, 2016 to January 31, 2017	Page
• Changed document status from Advance Information to Production Data.....	1
• Updated all electrical and timing specifications and typical characteristics graphs with production data.....	29

Changes from initial release to revision A

Changes from March 17, 2016 to October 17, 2016	Page
• Changed from <i>35x Faster</i> to <i>Up to 40x Faster</i> in the list item that starts "Efficient 256-Point Complex FFT..." in Section 1, Features	1
• Added Section 6.1, Related Products	8
• Added second row to t_{Sample} parameter in Section 8.12.9.2, 12-Bit ADC, Timing Parameters	58
• Removed ADC12DIV from equation for the t_{CONVERT} TYP time, because ADC12CLK is after division.....	58
• Added " $R_S < 10 \text{ k}\Omega$ " to the note that starts "Approximately 10 Tau (τ) are needed..." on Section 8.12.9.2, 12-Bit ADC, Timing Parameters	58

- Changed from "If the $\overline{\text{RST}}/\text{NMI}$ pin is unused...with a 2.2-nF pulldown capacitor" to "If the $\overline{\text{RST}}/\text{NMI}$ pin is unused...with a 10-nF pulldown capacitor" in [Section 10.1.4, Reset](#) 150
-

6 Device Comparison

Table 6-1 summarizes the available family members.

Table 6-1. Device Comparison

DEVICE ^{(1) (2)}	FRAM Program + Information (KB)	SRAM (KB)	CLOCK SYSTEM	LEA	ADC12_B (Channels)	Comp_E	Timer_A ⁽³⁾	Timer_B ⁽⁴⁾	eUSCI_A ⁽⁵⁾	eUSCI_B ⁽⁶⁾	AES	BSL	I/Os	PACKAGE
MSP430FR5994	256 + 0.5	8	DCO HFXT LFXT	Yes	20 external, 2 internal	16 ch.	3, 3 ⁽⁷⁾ 2, 2, 2 ⁽⁸⁾	7	4	4	Yes	UART	68	80 PN (LQFP) 87 ZVW (NFBGA)
					17 external, 2 internal				3	3			54	64 PM (LQFP)
					16 external, 2 internal				2	1			40	48 RGZ (VQFN)
MSP430FR5992	128 + 0.5	8	DCO HFXT LFXT	Yes	20 external, 2 internal	16 ch.	3, 3 ⁽⁷⁾ 2, 2, 2 ⁽⁸⁾	7	4	4	Yes	UART	68	80 PN (LQFP) 87 ZVW (NFBGA)
					17 external, 2 internal				3	3			54	64 PM (LQFP)
					16 external, 2 internal				2	1			40	48 RGZ (VQFN)
MSP430FR5964	256 + 0.5	8	DCO HFXT LFXT	No	20 external, 2 internal	16 ch.	3, 3 ⁽⁷⁾ 2, 2, 2 ⁽⁸⁾	7	4	4	Yes	UART	68	80 PN (LQFP) 87 ZVW (NFBGA)
					17 external, 2 internal				3	3			54	64 PM (LQFP)
					16 external, 2 internal				2	1			40	48 RGZ (VQFN)
MSP430FR5962	128 + 0.5	8	DCO HFXT LFXT	No	20 external, 2 internal	16 ch.	3, 3 ⁽⁷⁾ 2, 2, 2 ⁽⁸⁾	7	4	4	Yes	UART	68	80 PN (LQFP) 87 ZVW (NFBGA)
					17 external, 2 internal				3	3			54	64 PM (LQFP)
					16 external, 2 internal				2	1			40	48 RGZ (VQFN)
MSP430FR59941	256 + 0.5	8	DCO HFXT LFXT	Yes	20 external, 2 internal	16 ch.	3, 3 ⁽⁷⁾ 2, 2, 2 ⁽⁸⁾	7	4	4	Yes	I ² C	68	80 PN (LQFP) 87 ZVW (NFBGA)
					17 external, 2 internal				3	3			54	64 PM (LQFP)
					16 external, 2 internal				2	1			40	48 RGZ (VQFN)

- (1) For the most current package and ordering information, see the *Package Option Addendum* in Section 12, or see the TI website at www.ti.com.
- (2) Package drawings, standard packing quantities, thermal data, symbolization, and PCB design guidelines are available at www.ti.com/packaging.
- (3) Each number in the sequence represents an instantiation of Timer_A with its associated number of capture/compare registers and PWM output generators available. For example, a number sequence of 3, 5 would represent two instantiations of Timer_A, the first instantiation having 3 capture/compare registers and PWM output generators and the second instantiation having 5 capture/compare registers and PWM output generators, respectively.

- (4) Each number in the sequence represents an instantiation of Timer_B with its associated number of capture/compare registers and PWM output generators available. For example, a number sequence of 3, 5 would represent two instantiations of Timer_B, the first instantiation having 3 capture/compare registers and PWM output generators and the second instantiation having 5 capture/compare registers and PWM output generators, respectively.
- (5) eUSCI_A supports UART with automatic baud-rate detection, IrDA encode and decode, and SPI.
- (6) eUSCI_B supports I²C with multiple slave addresses and SPI.
- (7) Timers TA0 and TA1 provide internal and external capture/compare inputs and internal and external PWM outputs.
- (8) Timers TA2 and TA3 provide only internal capture/compare inputs and only internal PWM outputs (if any). Timer TA4 provides internal and external capture/compare inputs and internal and external PWM outputs.
Note: TA4 in the RGZ package provides only internal capture/compare inputs and only internal PWM outputs.

6.1 Related Products

For information about other devices in this family of products or related products, see the following links.

[16-bit and 32-bit microcontrollers](#)

High-performance, low-power solutions to enable the autonomous future

[Products for MSP430 ultra-low-power sensing & measurement MCUs](#)

One platform. One ecosystem. Endless possibilities.

[Reference designs for MSP430FR5994](#)

Find reference designs leveraging the best in TI technology – from analog and power management to embedded processors.

7 Terminal Configuration and Functions

7.1 Pin Diagrams

Figure 7-1 shows the bottom view of the pinout of the 87-pin ZVW package, and Figure 7-2 shows the top view of the pinout.

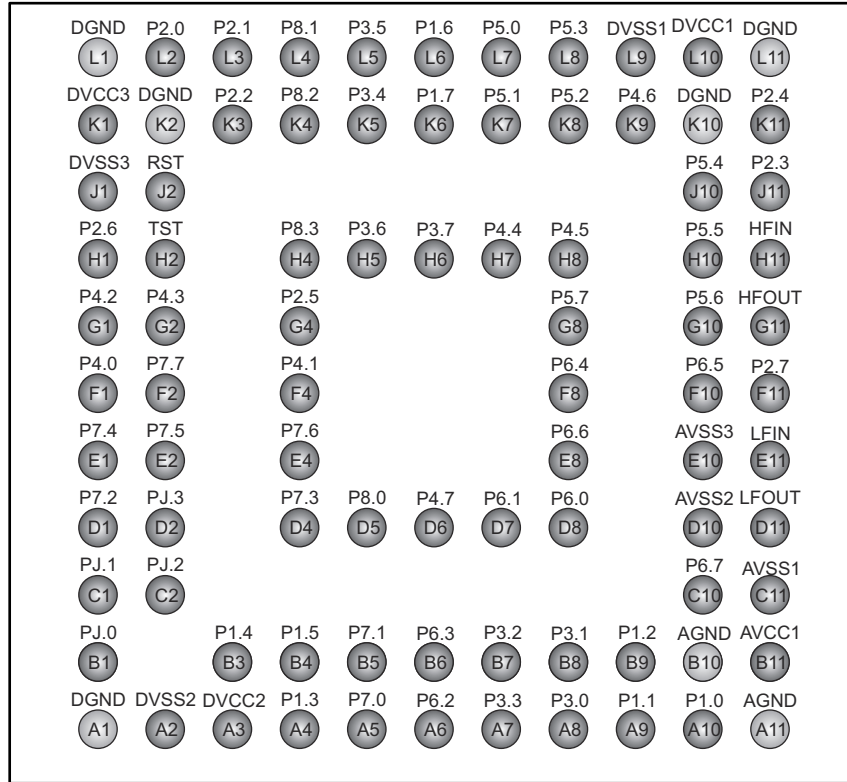

On devices with UART BSL: P2.0 is BSLTX, P2.1 is BSLRX
 On devices with I²C BSL: P1.6 is BSLSDA, P1.7 is BSLSCL

Figure 7-1. 87-Pin ZVW Package (Bottom View)

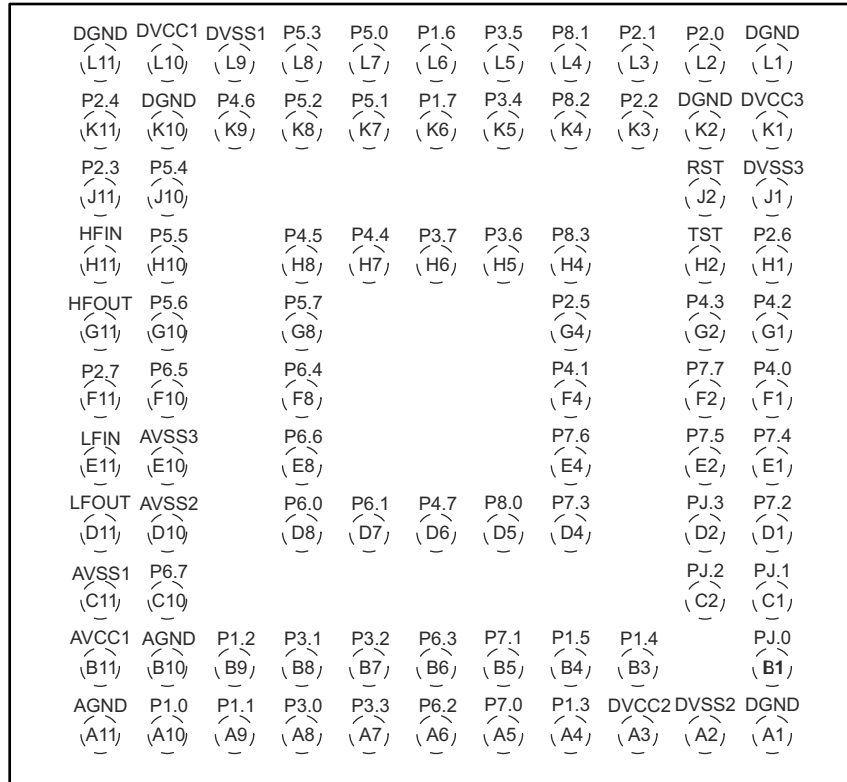
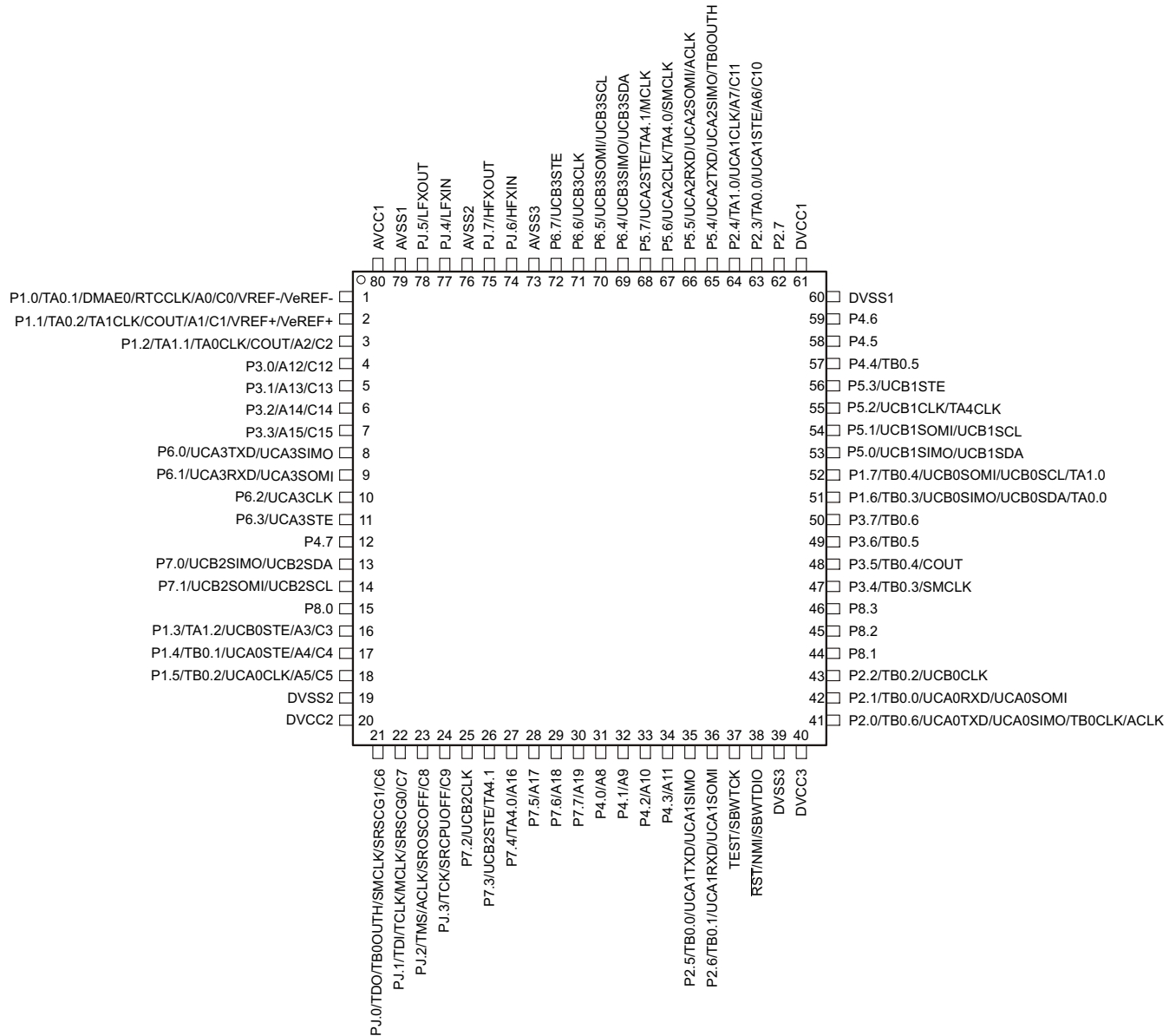

Figure 7-2. 87-Pin ZVW Package (Top View)

Figure 7-3 shows the pinout of the 80-pin PN package.



On devices with UART BSL: P2.0 is BSLTX, P2.1 is BSLRX
On devices with I²C BSL: P1.6 is BSLSDA, P1.7 is BSLSCL

Figure 7-3. 80-Pin PN Package (Top View)

Figure 7-4 shows the pinout of the 64-pin PM package.

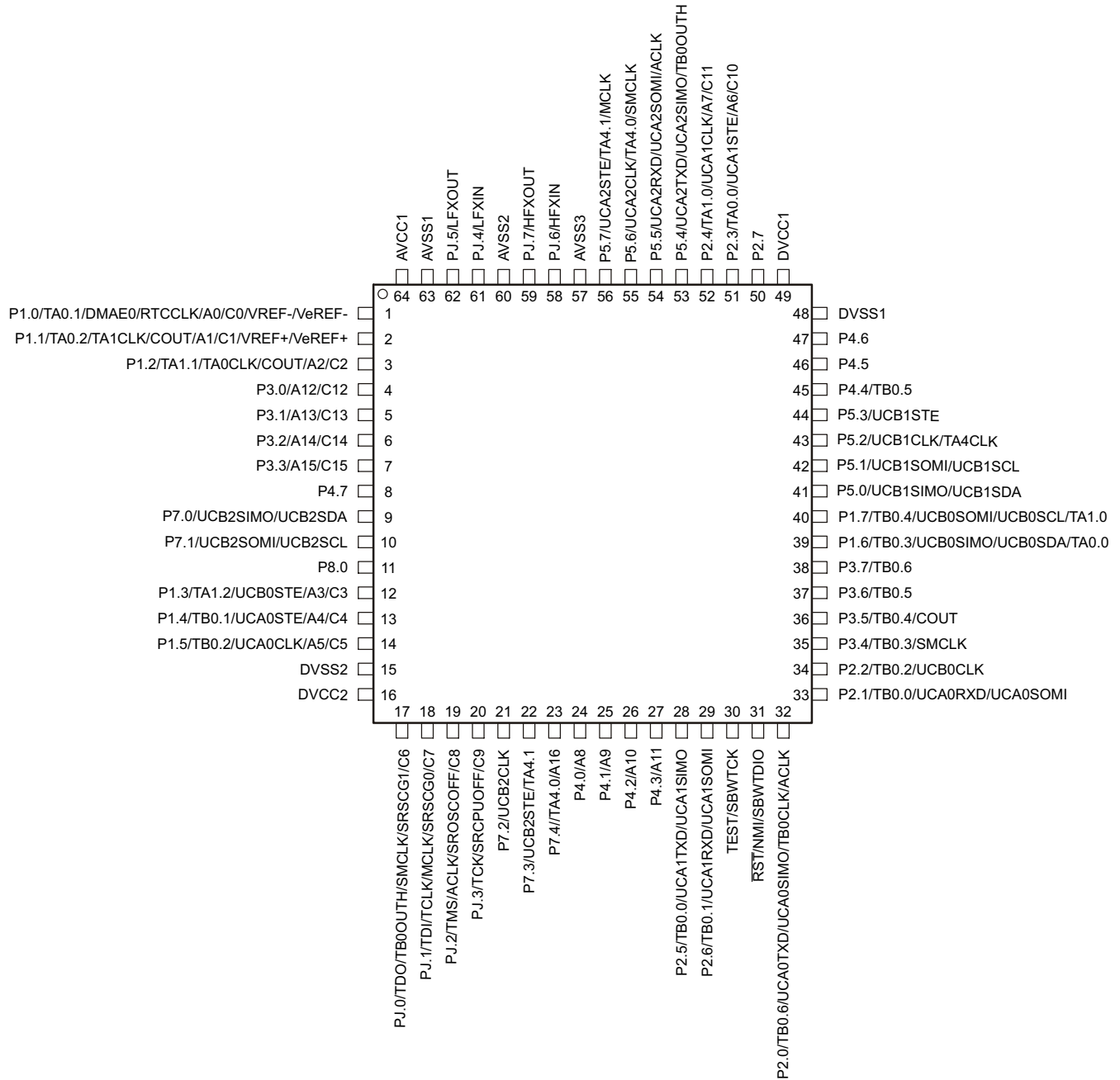
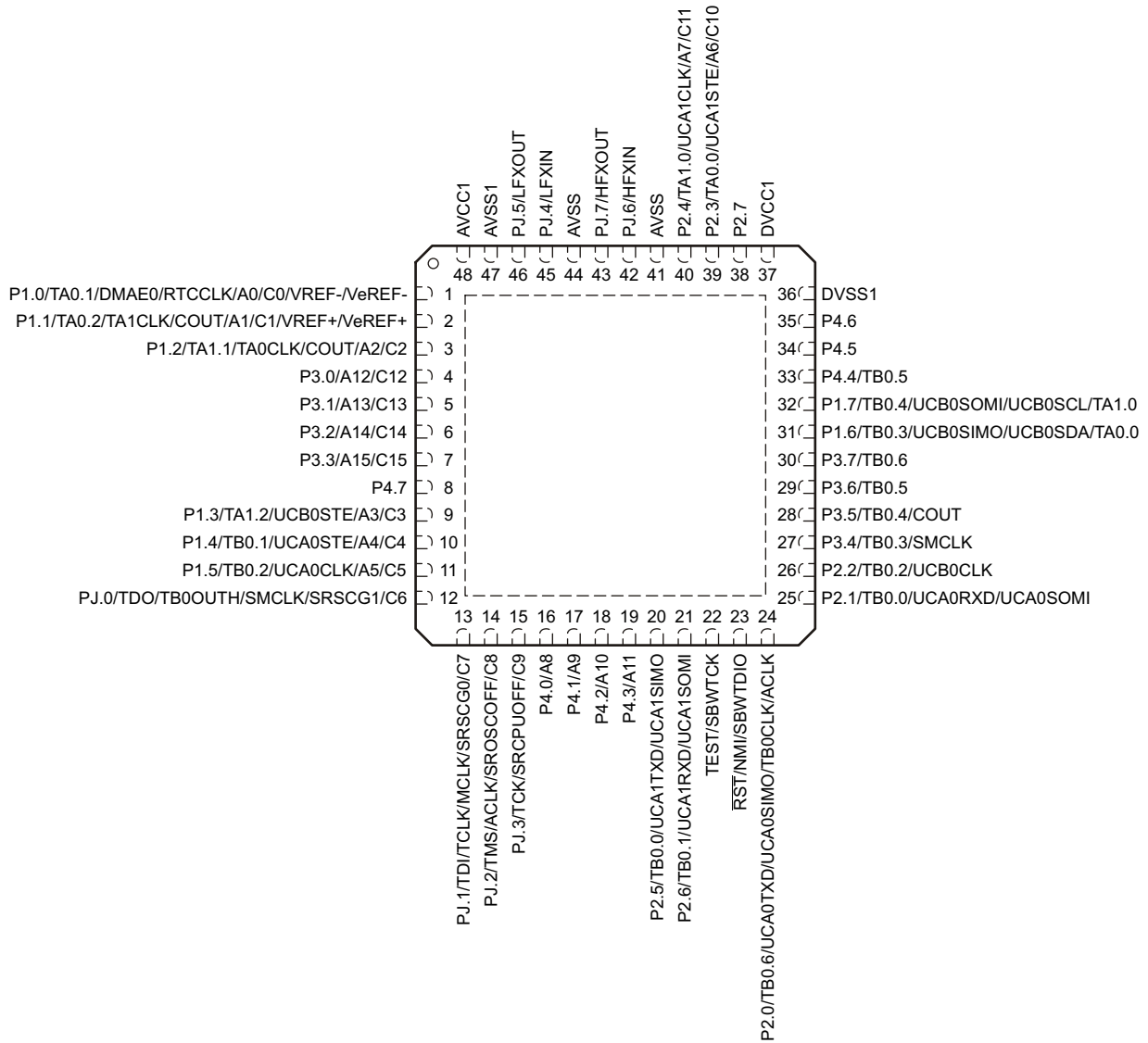

Figure 7-5 shows the pinout of the 48-pin RGZ package.



TI recommends connecting the QFN thermal pad to V_{SS} .
 On devices with UART BSL: P2.0 is BSLTX, P2.1 is BSLRX
 On devices with I²C BSL: P1.6 is BSLSDA, P1.7 is BSLSCL

Figure 7-5. 48-Pin RGZ Package (Top View)

7.2 Pin Attributes

Table 7-1 summarizes the attributes of the pins.

Table 7-1. Pin Attributes

PIN NUMBER ⁽¹⁾				SIGNAL NAME ^{(2) (3)}	SIGNAL TYPE ⁽⁴⁾	BUFFER TYPE ⁽⁵⁾	POWER SOURCE ⁽⁶⁾	RESET STATE AFTER BOR ⁽⁷⁾
PN	PM	RGZ	ZVW					
1	1	1	A10	P1.0	I/O	LVC MOS	DVCC	OFF
				TA0.1	I/O	LVC MOS	DVCC	–
				DMAE0	I	LVC MOS	DVCC	–
				RTCCLK	O	LVC MOS	DVCC	–
				A0	I	Analog	DVCC	–
				C0	I	Analog	DVCC	–
				VREF-	O	Analog	DVCC	–
				VeREF-	I	Analog	DVCC	–
2	2	2	A9	P1.1	I/O	LVC MOS	DVCC	OFF
				TA0.2	I/O	LVC MOS	DVCC	–
				TA1CLK	I	LVC MOS	DVCC	–
				COUT	O	LVC MOS	DVCC	–
				A1	I	Analog	DVCC	–
				C1	I	Analog	DVCC	–
				VREF+	O	Analog	DVCC	–
				VeREF+	I	Analog	DVCC	–
3	3	3	B9	P1.2	I/O	LVC MOS	DVCC	OFF
				TA1.1	I/O	LVC MOS	DVCC	–
				TA0CLK	I	LVC MOS	DVCC	–
				COUT	O	LVC MOS	DVCC	–
				A2	I	Analog	DVCC	–
				C2	I	Analog	DVCC	–
4	4	4	A8	P3.0	I/O	LVC MOS	DVCC	OFF
				A12	I	Analog	DVCC	–
				C12	I	Analog	DVCC	–
5	5	5	B8	P3.1	I/O	LVC MOS	DVCC	–
				A13	I	Analog	DVCC	–
				C13	I	Analog	DVCC	–
6	6	6	B7	P3.2	I/O	LVC MOS	DVCC	OFF
				A14	I	Analog	DVCC	–
				C14	I	Analog	DVCC	–
7	7	7	A7	P3.3	I/O	LVC MOS	DVCC	OFF
				A15	I	Analog	DVCC	–
				C15	I	Analog	DVCC	–
8	–	–	D8	P6.0	I/O	LVC MOS	DVCC	OFF
				UCA3TXD	O	LVC MOS	DVCC	–
				UCA3SIMO	I/O	LVC MOS	DVCC	–
9	–	–	D7	P6.1	I/O	LVC MOS	DVCC	OFF
				UCA3RXD	I	LVC MOS	DVCC	–
				UCA3SOMI	I/O	LVC MOS	DVCC	–

Table 7-1. Pin Attributes (continued)

PIN NUMBER ⁽¹⁾				SIGNAL NAME ^{(2) (3)}	SIGNAL TYPE ⁽⁴⁾	BUFFER TYPE ⁽⁵⁾	POWER SOURCE ⁽⁶⁾	RESET STATE AFTER BOR ⁽⁷⁾
PN	PM	RGZ	ZVW					
10	–	–	A6	P6.2	I/O	LVC MOS	DVCC	OFF
				UCA3CLK	I/O	LVC MOS	DVCC	–
11	–	–	B6	P6.3	I/O	LVC MOS	DVCC	OFF
				UCA3STE	I/O	LVC MOS	DVCC	–
12	8	8	D6	P4.7	I/O	LVC MOS	DVCC	OFF
13	9	–	A5	P7.0	I/O	LVC MOS	DVCC	OFF
				UCB2SIMO	I/O	LVC MOS	DVCC	–
				UCB2SDA	I/O	LVC MOS	DVCC	–
14	10	–	B5	P7.1	I/O	LVC MOS	DVCC	OFF
				UCB2SOMI	I/O	LVC MOS	DVCC	–
				UCB2SCL	I/O	LVC MOS	DVCC	–
15	11	–	D5	P8.0	I/O	LVC MOS	DVCC	OFF
16	12	9	A4	P1.3	I/O	LVC MOS	DVCC	OFF
				TA1.2	I/O	LVC MOS	DVCC	–
				UCB0STE	I/O	LVC MOS	DVCC	–
				A3	I	Analog	DVCC	–
				C3	I	Analog	DVCC	–
17	13	10	B3	P1.4	I/O	LVC MOS	DVCC	OFF
				TB0.1	I/O	LVC MOS	DVCC	–
				UCA0STE	I/O	LVC MOS	DVCC	–
				A4	I	Analog	DVCC	–
				C4	I	Analog	DVCC	–
18	14	11	B4	P1.5	I/O	LVC MOS	DVCC	OFF
				TB0.2	I/O	LVC MOS	DVCC	–
				UCA0CLK	I/O	LVC MOS	DVCC	–
				A5	I	Analog	DVCC	–
				C5	I	Analog	DVCC	–
19	15	–	A2	DVSS2	P	Power	–	N/A
20	16	–	A3	DVCC2	P	Power	–	N/A
21	17	12	B1	PJ.0	I/O	LVC MOS	DVCC	OFF
				TDO	O	LVC MOS	DVCC	–
				TB0OUTH	I	LVC MOS	DVCC	–
				SMCLK	O	LVC MOS	DVCC	–
				SRSCG1	O	LVC MOS	DVCC	–
				C6	I	Analog	DVCC	–
22	18	13	C1	PJ.1	I/O	LVC MOS	DVCC	OFF
				TDI	I	LVC MOS	DVCC	–
				TCLK	I	LVC MOS	DVCC	–
				MCLK	O	LVC MOS	DVCC	–
				SRSCG0	O	LVC MOS	DVCC	–
				C7	I	Analog	DVCC	–

Table 7-1. Pin Attributes (continued)

PIN NUMBER ⁽¹⁾				SIGNAL NAME ^{(2) (3)}	SIGNAL TYPE ⁽⁴⁾	BUFFER TYPE ⁽⁵⁾	POWER SOURCE ⁽⁶⁾	RESET STATE AFTER BOR ⁽⁷⁾
PN	PM	RGZ	ZVW					
23	19	14	C2	PJ.2	I/O	LVC MOS	DVCC	OFF
				TMS	I	LVC MOS	DVCC	–
				ACLK	O	LVC MOS	DVCC	–
				SROSCOFF	O	LVC MOS	DVCC	–
				C8	I	Analog	DVCC	–
24	20	15	D2	PJ.3	I/O	LVC MOS	DVCC	OFF
				TCK	I	LVC MOS	DVCC	–
				SRCPUOFF	O	LVC MOS	DVCC	–
				C9	I	Analog	DVCC	–
25	21	–	D1	P7.2	I/O	LVC MOS	DVCC	OFF
				UCB2CLK	I/O	LVC MOS	DVCC	–
26	22	–	D4	P7.3	I/O	LVC MOS	DVCC	OFF
				UCB2STE	I/O	LVC MOS	DVCC	–
				TA4.1	I/O	LVC MOS	DVCC	–
27	23	–	E1	P7.4	I/O	LVC MOS	DVCC	OFF
				TA4.0	I/O	LVC MOS	DVCC	–
				A16	I	Analog	DVCC	–
28	–	–	E2	P7.5	I/O	LVC MOS	DVCC	OFF
				A17	I	Analog	DVCC	–
29	–	–	E4	P7.6	I/O	LVC MOS	DVCC	OFF
				A18	I	Analog	DVCC	–
30	–	–	F2	P7.7	I/O	LVC MOS	DVCC	OFF
				A19	I	Analog	DVCC	–
31	24	16	F1	P4.0	I/O	LVC MOS	DVCC	OFF
				A8	I	Analog	DVCC	–
32	25	17	F4	P4.1	I/O	LVC MOS	DVCC	OFF
				A9	I	Analog	DVCC	–
33	26	18	G1	P4.2	I/O	LVC MOS	DVCC	OFF
				A10	I	Analog	DVCC	–
34	27	19	G2	P4.3	I/O	LVC MOS	DVCC	OFF
				A11	I	Analog	DVCC	–
35	28	20	G4	P2.5	I/O	LVC MOS	DVCC	OFF
				TB0.0	I/O	LVC MOS	DVCC	–
				UCA1TXD	O	LVC MOS	DVCC	–
				UCA1SIMO	I/O	LVC MOS	DVCC	–
36	29	21	H1	P2.6	I/O	LVC MOS	DVCC	OFF
				TB0.1	O	LVC MOS	DVCC	–
				UCA1RXD	I	LVC MOS	DVCC	–
				UCA1SOMI	I/O	LVC MOS	DVCC	–
37	30	22	H2	TEST	I	LVC MOS	DVCC	OFF
				SBWTCK	I	LVC MOS	DVCC	–
38	31	23	J2	RST	I	LVC MOS	DVCC	OFF
				NMI	I	LVC MOS	DVCC	–
				SBWTDIO	I/O	LVC MOS	DVCC	–

Table 7-1. Pin Attributes (continued)

PIN NUMBER ⁽¹⁾				SIGNAL NAME ^{(2) (3)}	SIGNAL TYPE ⁽⁴⁾	BUFFER TYPE ⁽⁵⁾	POWER SOURCE ⁽⁶⁾	RESET STATE AFTER BOR ⁽⁷⁾
PN	PM	RGZ	ZVW					
39	–	–	J1	DVSS3	P	Power	–	N/A
40	–	–	K1	DVCC3	P	Power	–	N/A
41	32	24	L2	P2.0	I/O	LVC MOS	DVCC	OFF
				TB0.6	I/O	LVC MOS	DVCC	–
				UCA0TXD	O	LVC MOS	DVCC	–
				BSLTX	O	LVC MOS	DVCC	–
				UCA0SIMO	I/O	LVC MOS	DVCC	–
				TB0CLK	I	LVC MOS	DVCC	–
				ACLK	O	LVC MOS	DVCC	–
42	33	25	L3	P2.1	I/O	LVC MOS	DVCC	OFF
				TB0.0	I/O	LVC MOS	DVCC	–
				UCA0RXD	I	LVC MOS	DVCC	–
				BSLRX	I	LVC MOS	DVCC	–
				UCA0SOMI	I/O	LVC MOS	DVCC	–
43	34	26	K3	P2.2	I/O	LVC MOS	DVCC	OFF
				TB0.2	O	LVC MOS	DVCC	–
				UCB0CLK	I/O	LVC MOS	DVCC	–
44	–	–	L4	P8.1	I/O	LVC MOS	DVCC	OFF
45	–	–	K4	P8.2	I/O	LVC MOS	DVCC	OFF
46	–	–	H4	P8.3	I/O	LVC MOS	DVCC	OFF
47	35	27	K5	P3.4	I/O	LVC MOS	DVCC	OFF
				TB0.3	I/O	LVC MOS	DVCC	–
				SMCLK	O	LVC MOS	DVCC	–
48	36	28	L5	P3.5	I/O	LVC MOS	DVCC	OFF
				TB0.4	I/O	LVC MOS	DVCC	–
				COUT	O	LVC MOS	DVCC	–
49	37	29	H5	P3.6	I/O	LVC MOS	DVCC	OFF
				TB0.5	I/O	LVC MOS	DVCC	–
50	38	30	H6	P3.7	I/O	LVC MOS	DVCC	OFF
				TB0.6	I/O	LVC MOS	DVCC	–
51	39	31	L6	P1.6	I/O	LVC MOS	DVCC	OFF
				TB0.3	I/O	LVC MOS	DVCC	–
				UCB0SIMO	I/O	LVC MOS	DVCC	–
				UCB0SDA	I/O	LVC MOS	DVCC	–
				BSLSDA	I/O	LVC MOS	DVCC	–
				TA0.0	I/O	LVC MOS	DVCC	–
52	40	32	K6	P1.7	I/O	LVC MOS	DVCC	OFF
				TB0.4	I/O	LVC MOS	DVCC	–
				UCB0SOMI	I/O	LVC MOS	DVCC	–
				UCB0SCL	I/O	LVC MOS	DVCC	–
				BSLSCL	I/O	LVC MOS	DVCC	–
				TA1.0	I/O	LVC MOS	DVCC	–

Table 7-1. Pin Attributes (continued)

PIN NUMBER ⁽¹⁾				SIGNAL NAME ^{(2) (3)}	SIGNAL TYPE ⁽⁴⁾	BUFFER TYPE ⁽⁵⁾	POWER SOURCE ⁽⁶⁾	RESET STATE AFTER BOR ⁽⁷⁾
PN	PM	RGZ	ZVW					
53	41	–	L7	P5.0	I/O	LVC MOS	DVCC	OFF
				UCB1SIMO	I/O	LVC MOS	DVCC	–
				UCB1SDA	I/O	LVC MOS	DVCC	–
54	42	–	K7	P5.1	I/O	LVC MOS	DVCC	OFF
				UCB1SOMI	I/O	LVC MOS	DVCC	–
				UCB1SCL	I/O	LVC MOS	DVCC	–
55	43	–	K8	P5.2	I/O	LVC MOS	DVCC	OFF
				UCB1CLK	I/O	LVC MOS	DVCC	–
				TA4CLK	I	LVC MOS	DVCC	–
56	44	–	L8	P5.3	I/O	LVC MOS	DVCC	OFF
				UCB1STE	I/O	LVC MOS	DVCC	–
57	45	33	H7	P4.4	I/O	LVC MOS	DVCC	OFF
				TB0.5	I/O	LVC MOS	DVCC	–
58	46	34	H8	P4.5	I/O	LVC MOS	DVCC	OFF
59	47	35	K9	P4.6	I/O	LVC MOS	DVCC	OFF
60	48	36	L9	DVSS1	P	Power	–	N/A
61	49	37	L10	DVCC1	P	Power	–	N/A
62	50	38	F11	P2.7	I/O	LVC MOS	DVCC	OFF
63	51	39	J11	P2.3	I/O	LVC MOS	DVCC	OFF
				TA0.0	I/O	LVC MOS	DVCC	–
				UCA1STE	I/O	LVC MOS	DVCC	–
				A6	I	Analog	DVCC	–
				C10	I	Analog	DVCC	–
64	52	40	K11	P2.4	I/O	LVC MOS	DVCC	OFF
				TA1.0	I/O	LVC MOS	DVCC	–
				UCA1CLK	I/O	LVC MOS	DVCC	–
				A7	I	Analog	DVCC	–
				C11	I	Analog	DVCC	–
65	53	–	J10	P5.4	I/O	LVC MOS	DVCC	OFF
				UCA2TXD	O	LVC MOS	DVCC	–
				UCA2SIMO	I/O	LVC MOS	DVCC	–
				TB0OUTH	I	LVC MOS	DVCC	–
66	54	–	H10	P5.5	I/O	LVC MOS	DVCC	OFF
				UCA2RXD	I	LVC MOS	DVCC	–
				UCA2SOMI	I/O	LVC MOS	DVCC	–
				ACLK	O	LVC MOS	DVCC	–
67	55	–	G10	P5.6	I/O	LVC MOS	DVCC	OFF
				UCA2CLK	I/O	LVC MOS	DVCC	–
				TA4.0	I/O	LVC MOS	DVCC	–
				SMCLK	O	LVC MOS	DVCC	–
68	56	–	G8	P5.7	I/O	LVC MOS	DVCC	OFF
				UCA2STE	I/O	LVC MOS	DVCC	–
				TA4.1	I/O	LVC MOS	DVCC	–
				MCLK	O	LVC MOS	DVCC	–

Table 7-1. Pin Attributes (continued)

PIN NUMBER ⁽¹⁾				SIGNAL NAME ^{(2) (3)}	SIGNAL TYPE ⁽⁴⁾	BUFFER TYPE ⁽⁵⁾	POWER SOURCE ⁽⁶⁾	RESET STATE AFTER BOR ⁽⁷⁾
PN	PM	RGZ	ZVW					
69	–	–	F8	P6.4	I/O	LVC MOS	DVCC	OFF
				UCB3SIMO	I/O	LVC MOS	DVCC	–
				UCB3SDA	I/O	LVC MOS	DVCC	–
70	–	–	F10	P6.5	I/O	LVC MOS	DVCC	OFF
				UCB3SOMI	I/O	LVC MOS	DVCC	–
				UCB3SCL	I/O	LVC MOS	DVCC	–
71	–	–	E8	P6.6	I/O	LVC MOS	DVCC	OFF
				UCB3CLK	I/O	LVC MOS	DVCC	–
72	–	–	C10	P6.7	I/O	LVC MOS	DVCC	OFF
				UCB3STE	I/O	LVC MOS	DVCC	–
73	57	41	E10	AVSS3	P	Power	–	N/A
74	58	42	H11	PJ.6	I/O	LVC MOS	DVCC	–
				HFXIN	I	Analog	DVCC	–
75	59	43	G11	PJ.7	I/O	LVC MOS	DVCC	OFF
				HFXOUT	O	Analog	DVCC	–
76	60	44	D10	AVSS2	P	Power	–	N/A
77	61	45	E11	PJ.4	I/O	LVC MOS	DVCC	OFF
				LFXIN	I	Analog	DVCC	–
78	62	46	D11	PJ.5	I/O	LVC MOS	DVCC	OFF
				LFXOUT	O	Analog	DVCC	–
79	63	47	C11	AVSS1	P	Power	–	N/A
80	64	48	B11	AVCC1	P	Power	–	N/A
–	–	–	A1	DGND	P	Power	–	N/A
–	–	–	A11	AGND	P	Power	–	N/A
–	–	–	B10	AGND	P	Power	–	N/A
–	–	–	K2	DGND	P	Power	–	N/A
–	–	–	K10	DGND	P	Power	–	N/A
–	–	–	L1	DGND	P	Power	–	N/A
–	–	–	L11	DGND	P	Power	–	N/A
–	–	Pad	–	QFN Pad	P	Power	–	N/A

(1) N/A = not available

(2) The signal that is listed first for each pin is the reset default pin name.

(3) Signal Types: I = Input, O = Output, I/O = Input or Output.

(4) Buffer Types: LVC MOS, Analog, or Power (see [Table 7-3](#) for details)

(5) To determine the pin mux encodings for each pin, see [Section 9.13](#).

(6) The power source shown in this table is the I/O power source, which may differ from the module power source.

(7) Reset States:

OFF = High impedance with Schmitt-trigger input and pullup or pulldown (if available) disabled

N/A = Not applicable

7.3 Signal Descriptions

Section 7.3 describes the signals for all device variants and package options.

Table 7-2. Signal Descriptions

FUNCTION	SIGNAL NAME	PIN NO. ⁽¹⁾				PIN TYPE ⁽²⁾	DESCRIPTION
		ZVW	PN	PM	RGZ		
ADC	A0	A10	1	1	1	I	ADC analog input A0
	A1	A9	2	2	2	I	ADC analog input A1
	A2	B9	3	3	3	I	ADC analog input A2
	A3	A4	16	12	9	I	ADC analog input A3
	A4	B3	17	13	10	I	ADC analog input A4
	A5	B4	18	14	11	I	ADC analog input A5
	A6	J11	63	51	39	I	ADC analog input A6
	A7	K11	64	52	40	I	ADC analog input A7
	A8	F1	31	24	16	I	ADC analog input A8
	A9	F4	32	25	17	I	ADC analog input A9
	A10	G1	33	26	18	I	ADC analog input A10
	A11	G2	34	27	19	I	ADC analog input A11
	A12	A8	4	4	4	I	ADC analog input A12
	A13	B8	5	5	5	I	ADC analog input A13
	A14	B7	6	6	6	I	ADC analog input A14
	A15	A7	7	7	7	I	ADC analog input A15
	A16	E1	27	23	–	I	ADC analog input A16
	A17	E2	28	–	–	I	ADC analog input A17
	A18	E4	29	–	–	I	ADC analog input A18
	A19	F2	30	–	–	I	ADC analog input A19
	VREF+	A9	2	2	2	O	Output of positive reference voltage
	VREF-	A10	1	1	1	O	Output of negative reference voltage
	VeREF+	A9	2	2	2	I	Input for an external positive reference voltage to the ADC
	VeREF-	A10	1	1	1	I	Input for an external negative reference voltage to the ADC
BSL (I ² C)	BSLSCL	K6	52	40	32	I/O	I ² C BSL clock
	BSLSDA	L6	51	39	31	I/O	I ² C BSL data
BSL (UART)	BSLRX	L3	42	33	25	I	UART BSL receive
	BSLTX	L2	41	32	24	O	UART BSL transmit
Clock	ACLK	C2	23	19	14	O	ACLK output
		H10	41	32	24		
			66	54			
	HFXIN	H11	74	58	42	I	Input for high-frequency crystal oscillator HFXT
	HFXOUT	G11	75	59	43	O	Output for high-frequency crystal oscillator HFXT
	LFXIN	E11	77	61	45	I	Input for low-frequency crystal oscillator LFXT
LFXOUT	D11	78	62	46	O	Output of low-frequency crystal oscillator LFXT	
MCLK	C1	22	18	13	O	MCLK output	
	G8	68	56				
SMCLK		B1	21	17	12	O	SMCLK output
		G10	47	35	27		
			67	55			

Table 7-2. Signal Descriptions (continued)

FUNCTION	SIGNAL NAME	PIN NO. ⁽¹⁾				PIN TYPE ⁽²⁾	DESCRIPTION
		ZVW	PN	PM	RGZ		
Comparator	C0	A10	1	1	1	I	Comparator input C0
	C1	A9	2	2	2	I	Comparator input C1
	C2	B9	3	3	3	I	Comparator input C2
	C3	A4	16	12	9	I	Comparator input C3
	C4	B3	17	13	10	I	Comparator input C4
	C5	B4	18	14	11	I	Comparator input C5
	C6	B1	21	17	12	I	Comparator input C6
	C7	C1	22	18	13	I	Comparator input C7
	C8	C2	23	19	14	I	Comparator input C8
	C9	D2	24	20	15	I	Comparator input C9
	C10	J11	63	51	39	I	Comparator input C10
	C11	K11	64	52	40	I	Comparator input C11
	C12	A8	4	4	4	I	Comparator input C12
	C13	B8	5	5	5	I	Comparator input C13
	C14	B7	6	6	6	I	Comparator input C14
	C15	A7	7	7	7	I	Comparator input C15
	COUT	A9 B9 L5	2 3 48	2 3 36	2 3 28	O	Comparator output
DMA	DMAE0	A10	1	1	1	I	External DMA trigger
Debug	SBWTCK	H2	37	30	22	I	Spy-Bi-Wire input clock
	SBWTDIO	J2	38	31	23	I/O	Spy-Bi-Wire data input/output
	SRCPUOFF	D2	24	20	15	O	Low-power debug: CPU Status register bit CPUOFF
	SROSCOFF	C2	23	19	14	O	Low-power debug: CPU Status register bit OSCOFF
	SRSCG0	C1	22	18	13	O	Low-power debug: CPU Status register bit SCG0
	SRSCG1	B1	21	17	12	O	Low-power debug: CPU Status register bit SCG1
	TCK	D2	24	20	15	I	Test clock
	TCLK	C1	22	18	13	I	Test clock input
	TDI	C1	22	18	13	I	Test data input
	TDO	B1	21	17	12	O	Test data output port
	TEST	H2	37	30	22	I	Test mode pin – select digital I/O on JTAG pins
	TMS	C2	23	19	14	I	Test mode select

Table 7-2. Signal Descriptions (continued)

FUNCTION	SIGNAL NAME	PIN NO. ⁽¹⁾				PIN TYPE ⁽²⁾	DESCRIPTION
		ZVW	PN	PM	RGZ		
GPIO	P1.0	A10	1	1	1	I/O	General-purpose digital I/O with port interrupt and wake up from LPMx.5
	P1.1	A9	2	2	2	I/O	General-purpose digital I/O with port interrupt and wake up from LPMx.5
	P1.2	B9	3	3	3	I/O	General-purpose digital I/O with port interrupt and wake up from LPMx.5
	P1.3	A4	16	12	9	I/O	General-purpose digital I/O with port interrupt and wake up from LPMx.5
	P1.4	B3	17	13	10	I/O	General-purpose digital I/O with port interrupt and wake up from LPMx.5
	P1.5	B4	18	14	11	I/O	General-purpose digital I/O with port interrupt and wake up from LPMx.5
	P1.6	L6	51	39	31	I/O	General-purpose digital I/O with port interrupt and wake up from LPMx.5
	P1.7	K6	52	40	32	I/O	General-purpose digital I/O with port interrupt and wake up from LPMx.5
GPIO	P2.0	L2	41	32	24	I/O	General-purpose digital I/O with port interrupt and wake up from LPMx.5
	P2.1	L3	42	33	25	I/O	General-purpose digital I/O with port interrupt and wake up from LPMx.5
	P2.2	K3	43	34	26	I/O	General-purpose digital I/O with port interrupt and wake up from LPMx.5
	P2.3	J11	63	51	39	I/O	General-purpose digital I/O with port interrupt and wake up from LPMx.5
	P2.4	K11	64	52	40	I/O	General-purpose digital I/O with port interrupt and wake up from LPMx.5
	P2.5	G4	35	28	20	I/O	General-purpose digital I/O with port interrupt and wake up from LPMx.5
	P2.6	H1	36	29	21	I/O	General-purpose digital I/O with port interrupt and wake up from LPMx.5
	P2.7	F11	62	50	38	I/O	General-purpose digital I/O with port interrupt and wake up from LPMx.5
GPIO	P3.0	A8	4	4	4	I/O	General-purpose digital I/O with port interrupt and wake up from LPMx.5
	P3.1	B8	5	5	5	I/O	General-purpose digital I/O with port interrupt and wake up from LPMx.5
	P3.2	B7	6	6	6	I/O	General-purpose digital I/O with port interrupt and wake up from LPMx.5
	P3.3	A7	7	7	7	I/O	General-purpose digital I/O with port interrupt and wake up from LPMx.5
	P3.4	K5	47	35	27	I/O	General-purpose digital I/O with port interrupt and wake up from LPMx.5
	P3.5	L5	48	36	28	I/O	General-purpose digital I/O with port interrupt and wake up from LPMx.5
	P3.6	H5	49	37	29	I/O	General-purpose digital I/O with port interrupt and wake up from LPMx.5
	P3.7	H6	50	38	30	I/O	General-purpose digital I/O with port interrupt and wake up from LPMx.5

Table 7-2. Signal Descriptions (continued)

FUNCTION	SIGNAL NAME	PIN NO. ⁽¹⁾				PIN TYPE ⁽²⁾	DESCRIPTION
		ZVW	PN	PM	RGZ		
GPIO	P4.0	F1	31	24	16	I/O	General-purpose digital I/O with port interrupt and wake up from LPMx.5
	P4.1	F4	32	25	17	I/O	General-purpose digital I/O with port interrupt and wake up from LPMx.5
	P4.2	G1	33	26	18	I/O	General-purpose digital I/O with port interrupt and wake up from LPMx.5
	P4.3	G2	34	27	19	I/O	General-purpose digital I/O with port interrupt and wake up from LPMx.5
	P4.4	H7	57	45	33	I/O	General-purpose digital I/O with port interrupt and wake up from LPMx.5
	P4.5	H8	58	46	34	I/O	General-purpose digital I/O with port interrupt and wake up from LPMx.5
	P4.6	K9	59	47	35	I/O	General-purpose digital I/O with port interrupt and wake up from LPMx.5
	P4.7	D6	12	8	8	I/O	General-purpose digital I/O with port interrupt and wake up from LPMx.5
GPIO	P5.0	L7	53	41	–	I/O	General-purpose digital I/O with port interrupt and wake up from LPMx.5
	P5.1	K7	54	42	–	I/O	General-purpose digital I/O with port interrupt and wake up from LPMx.5
	P5.2	K8	55	43	–	I/O	General-purpose digital I/O with port interrupt and wake up from LPMx.5
	P5.3	L8	56	44	–	I/O	General-purpose digital I/O with port interrupt and wake up from LPMx.5
	P5.4	J10	65	53	–	I/O	General-purpose digital I/O with port interrupt and wake up from LPMx.5
	P5.5	H10	66	54	–	I/O	General-purpose digital I/O with port interrupt and wake up from LPMx.5
	P5.6	G10	67	55	–	I/O	General-purpose digital I/O with port interrupt and wake up from LPMx.5
	P5.7	G8	68	56	–	I/O	General-purpose digital I/O with port interrupt and wake up from LPMx.5
GPIO	P6.0	D8	8	–	–	I/O	General-purpose digital I/O with port interrupt and wake up from LPMx.5
	P6.1	D7	9	–	–	I/O	General-purpose digital I/O with port interrupt and wake up from LPMx.5
	P6.2	A6	10	–	–	I/O	General-purpose digital I/O with port interrupt and wake up from LPMx.5
	P6.3	B6	11	–	–	I/O	General-purpose digital I/O with port interrupt and wake up from LPMx.5
	P6.4	F8	69	–	–	I/O	General-purpose digital I/O with port interrupt and wake up from LPMx.5
	P6.5	F10	70	–	–	I/O	General-purpose digital I/O with port interrupt and wake up from LPMx.5
	P6.6	E8	71	–	–	I/O	General-purpose digital I/O with port interrupt and wake up from LPMx.5
	P6.7	C10	72	–	–	I/O	General-purpose digital I/O with port interrupt and wake up from LPMx.5

Table 7-2. Signal Descriptions (continued)

FUNCTION	SIGNAL NAME	PIN NO. ⁽¹⁾				PIN TYPE ⁽²⁾	DESCRIPTION
		ZVW	PN	PM	RGZ		
GPIO	P7.0	A5	13	9	–	I/O	General-purpose digital I/O with port interrupt and wake up from LPMx.5
	P7.1	B5	14	10	–	I/O	General-purpose digital I/O with port interrupt and wake up from LPMx.5
	P7.2	D1	25	21	–	I/O	General-purpose digital I/O with port interrupt and wake up from LPMx.5
	P7.3	D4	26	22	–	I/O	General-purpose digital I/O with port interrupt and wake up from LPMx.5
	P7.4	E1	27	23	–	I/O	General-purpose digital I/O with port interrupt and wake up from LPMx.5
	P7.5	E2	28	–	–	I/O	General-purpose digital I/O with port interrupt and wake up from LPMx.5
	P7.6	E4	29	–	–	I/O	General-purpose digital I/O with port interrupt and wake up from LPMx.5
	P7.7	F2	30	–	–	I/O	General-purpose digital I/O with port interrupt and wake up from LPMx.5
GPIO	P8.0	D5	15	11	–	I/O	General-purpose digital I/O with port interrupt and wake up from LPMx.5
	P8.1	L4	44	–	–	I/O	General-purpose digital I/O with port interrupt and wake up from LPMx.5
	P8.2	K4	45	–	–	I/O	General-purpose digital I/O with port interrupt and wake up from LPMx.5
	P8.3	H4	46	–	–	I/O	General-purpose digital I/O with port interrupt and wake up from LPMx.5
GPIO	PJ.0	B1	21	17	12	I/O	General-purpose digital I/O
	PJ.1	C1	22	18	13	I/O	General-purpose digital I/O
	PJ.2	C2	23	19	14	I/O	General-purpose digital I/O
	PJ.3	D2	24	20	15	I/O	General-purpose digital I/O
	PJ.4	E11	77	61	45	I/O	General-purpose digital I/O
	PJ.5	D11	78	62	46	I/O	General-purpose digital I/O
	PJ.6	H11	74	58	42	I/O	General-purpose digital I/O
	PJ.7	G11	75	59	43	I/O	General-purpose digital I/O
I ² C	UCB0SCL	K6	52	40	32	I/O	I ² C clock – eUSCI_B0 I ² C mode
	UCB0SDA	L6	51	39	31	I/O	I ² C data – eUSCI_B0 I ² C mode
	UCB1SCL	K7	54	42	–	I/O	I ² C clock – eUSCI_B1 I ² C mode
	UCB1SDA	L7	53	41	–	I/O	I ² C data – eUSCI_B1 I ² C mode
	UCB2SCL	B5	14	10	–	I/O	I ² C clock – eUSCI_B2 I ² C mode
	UCB2SDA	A5	13	9	–	I/O	I ² C data – eUSCI_B2 I ² C mode
	UCB3SCL	F10	70	–	–	I/O	I ² C clock – eUSCI_B3 I ² C mode
	UCB3SDA	F8	69	–	–	I/O	I ² C data – eUSCI_B3 I ² C mode

Table 7-2. Signal Descriptions (continued)

FUNCTION	SIGNAL NAME	PIN NO. ⁽¹⁾				PIN TYPE ⁽²⁾	DESCRIPTION
		ZVW	PN	PM	RGZ		
Power	AGND	B10 A11	–	–	–	P	Analog ground
	AVCC1	B11	80	64	48	P	Analog power supply
	AVSS1	C11	79	63	47	P	Analog ground supply
	AVSS2	D10	76	60	44	P	Analog ground supply
	AVSS3	E10	73	57	41	P	Analog ground supply
	DGND	A1 K2 K10 L1 L11	–	–	–	P	Digital ground
	DVCC1	L10	61	49	37	P	Digital power supply
	DVCC2	A3	20	16	–	P	Digital power supply
	DVCC3	K1	40	–	–	P	Digital power supply
	DVSS1	L9	60	48	36	P	Digital ground supply
	DVSS2	A2	19	15	–	P	Digital ground supply
	DVSS3	J1	39	–	–	P	Digital ground supply
	QFN Pad	–	–	–	Pad	P	QFN package exposed thermal pad. TI recommends connection to V _{SS} .
RTC	RTCCLK	A10	1	1	1	O	RTC clock calibration output (not available on MSP430FR5x5x devices)

Table 7-2. Signal Descriptions (continued)

FUNCTION	SIGNAL NAME	PIN NO. ⁽¹⁾				PIN TYPE ⁽²⁾	DESCRIPTION
		ZVW	PN	PM	RGZ		
SPI	UCA0CLK	B4	18	14	11	I/O	Clock signal input – eUSCI_A0 SPI slave mode Clock signal output – eUSCI_A0 SPI master mode
	UCA0SIMO	L2	41	32	24	I/O	Slave in/master out – eUSCI_A0 SPI mode
	UCA0SOMI	L3	42	33	25	I/O	Slave out/master in – eUSCI_A0 SPI mode
	UCA0STE	B3	17	13	10	I/O	Slave transmit enable – eUSCI_A0 SPI mode
	UCA1CLK	K11	64	52	40	I/O	Clock signal input – eUSCI_A1 SPI slave mode Clock signal output – eUSCI_A1 SPI master mode
	UCA1SIMO	G4	35	28	20	I/O	Slave in/master out – eUSCI_A1 SPI mode
	UCA1SOMI	H1	36	29	21	I/O	Slave out/master in – eUSCI_A1 SPI mode
	UCA1STE	J11	63	51	39	I/O	Slave transmit enable – eUSCI_A1 SPI mode
	UCA2CLK	G10	67	55	–	I/O	Clock signal input – eUSCI_A2 SPI slave mode Clock signal output – eUSCI_A2 SPI master mode
	UCA2SIMO	J10	65	53	–	I/O	Slave in/master out – eUSCI_A2 SPI mode
	UCA2SOMI	H10	66	54	–	I/O	Slave out/master in – eUSCI_A2 SPI mode
	UCA2STE	G8	68	56	–	I/O	Slave transmit enable – eUSCI_A2 SPI mode
	UCA3CLK	A6	10	–	–	I/O	Clock signal input – eUSCI_A3 SPI slave mode Clock signal output – eUSCI_A3 SPI master mode
	UCA3SIMO	D8	8	–	–	I/O	Slave in/master out – eUSCI_A3 SPI mode
	UCA3SOMI	D7	9	–	–	I/O	Slave out/master in – eUSCI_A3 SPI mode
	UCA3STE	B6	11	–	–	I/O	Slave transmit enable – eUSCI_A3 SPI mode
	UCB0CLK	K3	43	34	26	I/O	Clock signal input – eUSCI_B0 SPI slave mode Clock signal output – eUSCI_B0 SPI master mode
	UCB0SIMO	L6	51	39	31	I/O	Slave in/master out – eUSCI_B0 SPI mode
	UCB0SOMI	K6	52	40	32	I/O	Slave out/master in – eUSCI_B0 SPI mode
	UCB0STE	A4	16	12	9	I/O	Slave transmit enable – eUSCI_B0 SPI mode
	UCB1CLK	K8	55	43	–	I/O	Clock signal input – eUSCI_B1 SPI slave mode Clock signal output – eUSCI_B1 SPI master mode
	UCB1SIMO	L7	53	41	–	I/O	Slave in/master out – eUSCI_B1 SPI mode
	UCB1SOMI	K7	54	42	–	I/O	Slave out/master in – eUSCI_B1 SPI mode
	UCB1STE	L8	56	44	–	I/O	Slave transmit enable – eUSCI_B1 SPI mode
	UCB2CLK	D1	25	21	–	I/O	Clock signal input – eUSCI_B2 SPI slave mode Clock signal output – eUSCI_B2 SPI master mode
	UCB2SIMO	A5	13	9	–	I/O	Slave in/master out – eUSCI_B2 SPI mode
	UCB2SOMI	B5	14	10	–	I/O	Slave out/master in – eUSCI_B2 SPI mode
	UCB2STE	D4	26	22	–	I/O	Slave transmit enable – eUSCI_B2 SPI mode
UCB3CLK	E8	71	–	–	I/O	Clock signal input – eUSCI_B3 SPI slave mode Clock signal output – eUSCI_B3 SPI master mode	
UCB3SIMO	F8	69	–	–	I/O	Slave in/master out – eUSCI_B3 SPI mode	
UCB3SOMI	F10	70	–	–	I/O	Slave out/master in – eUSCI_B3 SPI mode	
UCB3STE	C10	72	–	–	I/O	Slave transmit enable – eUSCI_B3 SPI mode	
System	NMI	J2	38	31	23	I	Nonmaskable interrupt input
	RST	J2	38	31	23	I	Reset input active low

Table 7-2. Signal Descriptions (continued)

FUNCTION	SIGNAL NAME	PIN NO. ⁽¹⁾				PIN TYPE ⁽²⁾	DESCRIPTION
		ZVW	PN	PM	RGZ		
Timer	TA0.0	L6	51	39	31	I/O	TA0 CCR0 capture: CCI0A input, compare: Out0
	TA0.0	J11	63	51	39	I/O	TA0 CCR0 capture: CCI0B input, compare: Out0
	TA0.1	A10	1	1	1	I/O	TA0 CCR1 capture: CCI1A input, compare: Out1
	TA0.2	A9	2	2	2	I/O	TA0 CCR2 capture: CCI2A input, compare: Out2
	TA0CLK	B9	3	3	3	I	TA0 input clock
	TA1.0	K6	52	40	32	I/O	TA1 CCR0 capture: CCI0A input, compare: Out0
	TA1.0	K11	64	52	40	I/O	TA1 CCR0 capture: CCI0B input, compare: Out0
	TA1.1	B9	3	3	3	I/O	TA1 CCR1 capture: CCI1A input, compare: Out1
	TA1.2	A4	16	12	9	I/O	TA1 CCR2 capture: CCI2A input, compare: Out2
	TA1CLK	A9	2	2	2	I	TA1 input clock
	TA4.0	E1	27	23	–	I/O	TA4 CCR0 capture: CCI0B input, compare: Out0
	TA4.0	G10	67	55	–	I/O	TA4 CCR0 capture: CCI0A input, compare: Out0
	TA4.1	D4	26	22	–	I/O	TA4CCR1 capture: CCI1B input, compare: Out1
	TA4.1	G8	68	56	–	I/O	TA4 CCR1 capture: CCI1A input, compare: Out1
	TA4CLK	K8	55	43	–	I	TA4 input clock
	TB0.0	G4	35	28	20	I/O	TB0 CCR0 capture: CCI0B input, compare: Out0
	TB0.0	L3	42	33	25	I/O	TB0 CCR0 capture: CCI0A input, compare: Out0
	TB0.1	B3	17	13	10	I/O	TB0 CCR1 capture: CCI1A input, compare: Out1
	TB0.1	H1	36	29	21	O	TB0 CCR1 compare: Out1
	TB0.2	B4	18	14	11	I/O	TB0 CCR2 capture: CCI2A input, compare: Out2
	TB0.2	K3	43	34	26	O	TB0 CCR2 compare: Out2
	TB0.3	K5	47	35	27	I/O	TB0 CCR3 capture: CCI3A input, compare: Out3
	TB0.3	L6	51	39	31	I/O	TB0 CCR3 capture: CCI3B input, compare: Out3
	TB0.4	L5	48	36	28	I/O	TB0 CCR4 capture: CCI4A input, compare: Out4
	TB0.4	K6	52	40	32	I/O	TB0 CCR4 capture: CCI4B input, compare: Out4
	TB0.5	H5	49	37	29	I/O	TB0 CCR5 capture: CCI5A input, compare: Out5
	TB0.5	H7	57	45	33	I/O	TB0CCR5 capture: CCI5B input, compare: Out5
	TB0.6	L2	41	32	24	I/O	TB0 CCR6 capture: CCI6B input, compare: Out6
	TB0.6	H6	50	38	30	I/O	TB0 CCR6 capture: CCI6A input, compare: Out6
	TB0CLK	L2	41	32	24	I	TB0 clock input
TB0OUTH	B1 J10	21 65	17 53	12	I	Switch all PWM outputs high impedance input – TB0	
UART	UCA0RXD	L3	42	33	25	I	Receive data – eUSCI_A0 UART mode
	UCA0TXD	L2	41	32	24	O	Transmit data – eUSCI_A0 UART mode
	UCA1RXD	H1	36	29	21	I	Receive data – eUSCI_A1 UART mode
	UCA1TXD	G4	35	28	20	O	Transmit data – eUSCI_A1 UART mode
	UCA2RXD	H10	66	54	–	I	Receive data – eUSCI_A2 UART mode
	UCA2TXD	J10	65	53	–	O	Transmit data – eUSCI_A2 UART mode
	UCA3RXD	D7	9	–	–	I	Receive data – eUSCI_A3 UART mode
	UCA3TXD	D8	8	–	–	O	Transmit data – eUSCI_A3 UART mode

(1) N/A = not available

(2) I = input, O = output, P = power

7.4 Pin Multiplexing

Pin multiplexing for these devices is controlled by both register settings and operating modes (for example, if the device is in test mode). For details of the settings for each pin and schematics of the multiplexed ports, see [Section 9.13](#).

7.5 Buffer Types

[Table 7-3](#) describes the buffer types that are referenced in [Table 7-1](#).

Table 7-3. Buffer Type

BUFFER TYPE (STANDARD)	NOMINAL VOLTAGE	HYSTERESIS	PU OR PD ⁽¹⁾	NOMINAL PU OR PD STRENGTH (μA) ⁽¹⁾	OUTPUT DRIVE STRENGTH (mA) ⁽¹⁾	COMMENTS
Analog ⁽²⁾	3.0 V	No	N/A	N/A	N/A	See analog modules in Section 8 for details
LVC MOS	3.0 V	Yes ⁽³⁾	Programmable	See Section 8.12.5	See Section 8.12.5.3	
Power (DVCC) ⁽⁴⁾	3.0 V	No	N/A	N/A	N/A	SVS enables hysteresis on DVCC
Power (AVCC) ⁽⁴⁾	3.0 V	No	N/A	N/A	N/A	
Power (DVSS and AVSS) ⁽⁴⁾	0 V	No	N/A	N/A	N/A	

- (1) N/A = not applicable
- (2) This is a switch, not a buffer.
- (3) Only for input pins
- (4) This is supply input, not a buffer.

7.6 Connection of Unused Pins

[Table 7-4](#) lists the correct termination of all unused pins.

Table 7-4. Connection of Unused Pins

PIN ⁽¹⁾	POTENTIAL	COMMENT
AVCC	DV _{CC}	
AVSS	DV _{SS}	
Px.0 to Px.7	Open	Switched to port function, output direction (PxDIR.n = 1)
RST/NMI	DV _{CC} or V _{CC}	47-kΩ pullup or internal pullup selected with 10-nF (2.2 nF ⁽²⁾) pulldown
PJ.0/TDO PJ.1/TDI PJ.2/TMS PJ.3/TCK	Open	The JTAG pins are shared with general-purpose I/O function (PJ.x). If not being used, these should be switched to port function, output direction. When used as JTAG pins, these pins should remain open.
TEST	Open	This pin always has an internal pulldown enabled.

- (1) For any unused pin with a secondary function that is shared with general-purpose I/O, follow the guidelines for the Px.0 to Px.7 pins.
- (2) The pulldown capacitor should not exceed 2.2 nF when using devices with Spy-Bi-Wire interface in Spy-Bi-Wire mode or in 4-wire JTAG mode with TI tools like FET interfaces or GANG programmers.

8 Specifications

8.1 Absolute Maximum Ratings

over operating free-air temperature range (unless otherwise noted)⁽¹⁾

	MIN	MAX	UNIT
Voltage applied at DVCC and AVCC pins to V_{SS}	-0.3	4.1	V
Voltage difference between DVCC and AVCC pins ⁽¹⁾		±0.3	V
Voltage applied to any pin ⁽²⁾	-0.3	$V_{CC} + 0.3\text{ V}$ (4.1 V Max)	V
Diode current at any device pin		±2	mA
Storage temperature, T_{stg} ⁽³⁾	-40	125	°C

- (1) Voltage differences between DVCC and AVCC exceeding the specified limits may cause malfunction of the device including erroneous writes to RAM and FRAM.
- (2) All voltages referenced to V_{SS} .
- (3) Higher temperature may be applied during board soldering according to the current JEDEC J-STD-020 specification with peak reflow temperatures not higher than classified on the device label on the shipping boxes or reels.

8.2 ESD Ratings

		VALUE	UNIT
$V_{(ESD)}$ Electrostatic discharge	Human-body model (HBM), per ANSI/ESDA/JEDEC JS-001 ⁽¹⁾	±1000	V
	Charged-device model (CDM), per JEDEC specification JESD22-C101 ⁽²⁾	±250	

- (1) JEDEC document JEP155 states that 500-V HBM allows safe manufacturing with a standard ESD control process. Pins listed as ±1000 V may actually have higher performance.
- (2) JEDEC document JEP157 states that 250-V CDM allows safe manufacturing with a standard ESD control process. Pins listed as ±250 V may actually have higher performance.

8.3 Recommended Operating Conditions

TYP data are based on $V_{CC} = 3.0\text{ V}$ and $T_A = 25^\circ\text{C}$, unless otherwise noted

		MIN	NOM	MAX	UNIT
V_{CC}	Supply voltage range applied at all DVCC and AVCC pins ^{(1) (2) (3)}	1.8 ⁽⁶⁾		3.6	V
V_{SS}	Supply voltage applied at all DVSS and AVSS pins.		0		V
T_A	Operating free-air temperature	-40		85	°C
T_J	Operating junction temperature	-40		85	°C
C_{DVCC}	Capacitor value at DVCC ⁽⁴⁾	1–20%			µF
f_{SYSTEM}	Processor frequency (maximum MCLK frequency) ⁽⁵⁾	No FRAM wait states (NWAITSx = 0)		8 ⁽⁸⁾	MHz
		With FRAM wait states (NWAITSx = 1) ⁽⁷⁾		16 ⁽⁹⁾	
f_{ACLK}	Maximum ACLK frequency			50	kHz
f_{SMCLK}	Maximum SMCLK frequency			16 ⁽⁹⁾	MHz

- (1) TI recommends powering AVCC and DVCC pins from the same source. At a minimum, during power up, power down, and device operation, the voltage difference between AVCC and DVCC must not exceed the limits specified under *Absolute Maximum Ratings*. Exceeding the specified limits may cause malfunction of the device including erroneous writes to RAM and FRAM.
- (2) Fast supply voltage changes can trigger a BOR reset even within the recommended supply voltage range. To avoid unwanted BOR resets, the supply voltage must change by less than 0.05 V per microsecond ($\pm 0.05\text{ V}/\mu\text{s}$). Following the data sheet recommendation for capacitor C_{DVCC} should limit the slopes accordingly.
- (3) Modules may have a different supply voltage range specification. See the specification of the respective module in this data sheet.
- (4) For each supply pin pair (DVCC and DVSS, AVCC and AVSS), place a low-ESR ceramic capacitor of 100 nF (minimum) as close as possible (within a few millimeters) to the respective pin pairs.
- (5) Modules may have a different maximum input clock specification. See the specification of the respective module in this data sheet.
- (6) The minimum supply voltage is defined by the supervisor SVS levels. See the PMM SVS threshold parameters for the exact values.
- (7) Wait states only occur on actual FRAM accesses; that is, on FRAM cache misses. RAM and peripheral accesses are always executed without wait states.
- (8) DCO settings and HF crystals with a typical value less than or equal to the specified MAX value are permitted.
- (9) DCO settings and HF crystals with a typical value less than or equal to the specified MAX value are permitted. If a clock sources with a higher typical value is used, the clock must be divided in the clock system.

8.4 Active Mode Supply Current Into V_{CC} Excluding External Current

over recommended operating free-air temperature (unless otherwise noted)⁽¹⁾ ⁽²⁾ (see [Figure 8-1](#))

PARAMETER	EXECUTION MEMORY	V _{CC}	FREQUENCY (f _{MCLK} = f _{SMCLK})										UNIT
			1 MHz 0 WAIT STATES (NWAITSx = 0)		4 MHz 0 WAIT STATES (NWAITSx = 0)		8 MHz 0 WAIT STATES (NWAITSx = 0)		12 MHz 1 WAIT STATE (NWAITSx = 1)		16 MHz 1 WAIT STATE (NWAITSx = 1)		
			TYP	MAX	TYP	MAX	TYP	MAX	TYP	MAX	TYP	MAX	
I _{AM, FRAM_UNI} (Unified memory) ⁽³⁾	FRAM	3.0 V	225		665		1275		1550		1970		μA
I _{AM, FRAM(0%)} ⁽⁴⁾ ⁽⁵⁾	FRAM 0% cache hit ratio	3.0 V	420		1455		2850		2330		3000		μA
I _{AM, FRAM(50%)} ⁽⁴⁾ ⁽⁵⁾	FRAM 50% cache hit ratio	3.0 V	275		855		1650		1770		2265		μA
I _{AM, FRAM(66%)} ⁽⁴⁾ ⁽⁵⁾	FRAM 66% cache hit ratio	3.0 V	220		650		1240		1490		1880		μA
I _{AM, FRAM(75%)} ⁽⁴⁾ ⁽⁵⁾	FRAM 75% cache hit ratio	3.0 V	192	261	535		1015	1170	1290	1490	1620	1870	μA
I _{AM, FRAM(100%)} ⁽⁴⁾ ⁽⁵⁾	FRAM 100% cache hit ratio	3.0 V	125		255		450		670		790		μA
I _{AM, RAM} ⁽⁶⁾ ⁽⁵⁾	RAM	3.0 V	140		325		590		880		1070		μA
I _{AM, RAM only} ⁽⁷⁾ ⁽⁵⁾	RAM	3.0 V	90	182	280		540		830		1020	1313	μA

- (1) All inputs are tied to 0 V or to V_{CC}. Outputs do not source or sink any current.
- (2) Characterized with program executing typical data processing.
 $f_{ACLK} = 32768$ Hz, $f_{MCLK} = f_{SMCLK} = f_{DCO}$ at specified frequency, except for 12 MHz. For 12 MHz, $f_{DCO} = 24$ MHz and $f_{MCLK} = f_{SMCLK} = f_{DCO} / 2$.
 At MCLK frequencies above 8 MHz, the FRAM requires wait states. When wait states are required, the effective MCLK frequency ($f_{MCLK,eff}$) decreases. The effective MCLK frequency also depends on the cache hit ratio. SMCLK is not affected by the number of wait states or the cache hit ratio.
 The following equation can be used to compute $f_{MCLK,eff}$:
 $f_{MCLK,eff} = f_{MCLK} / [\text{wait states} \times (1 - \text{cache hit ratio}) + 1]$
 For example, with 1 wait state and 75% cache hit ratio $f_{MCLK,eff} = f_{MCLK} / [1 \times (1 - 0.75) + 1] = f_{MCLK} / 1.25$.
- (3) Represents typical program execution. Program and data reside entirely in FRAM. All execution is from FRAM.
- (4) Program resides in FRAM. Data resides in SRAM. Average current dissipation varies with cache hit-to-miss ratio as specified. Cache hit ratio represents number cache accesses divided by the total number of FRAM accesses. For example, a 75% ratio implies three of every four accesses is from cache, and the remaining are FRAM accesses.
- (5) See [Figure 8-1](#) for typical curves. The characteristic equation shown in the graph is computed using the least squares method for best linear fit using the typical data shown in [Section 8.4](#).
- (6) Program and data reside entirely in RAM. All execution is from RAM.
- (7) Program and data reside entirely in RAM. All execution is from RAM. FRAM is off.

8.5 Typical Characteristics, Active Mode Supply Currents

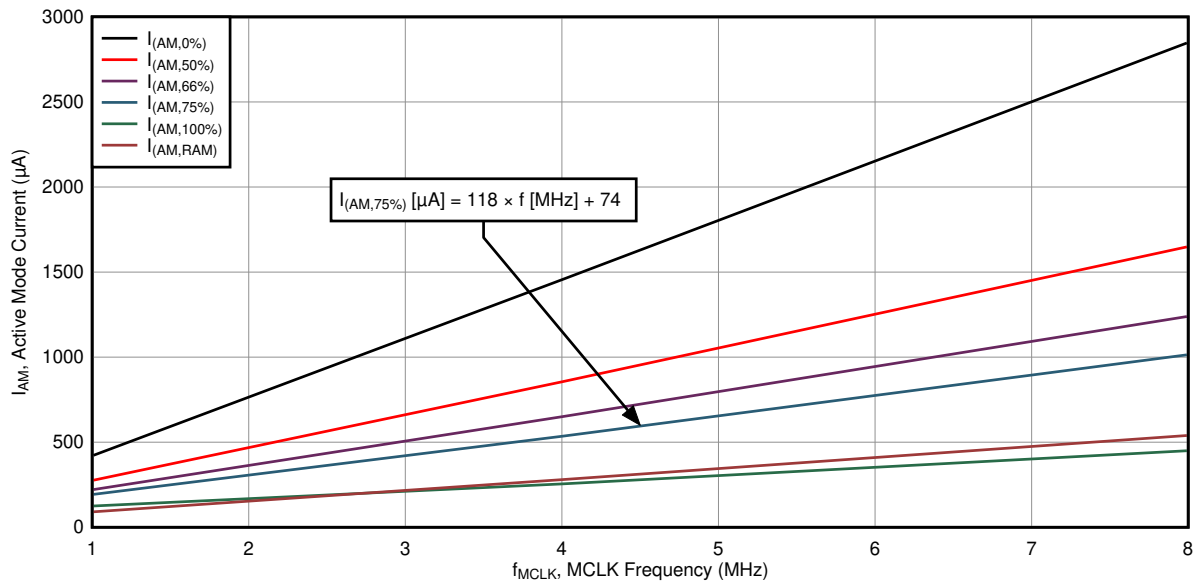

Figure 8-1. Typical Active Mode Supply Currents, No Wait States

8.6 Low-Power Mode (LPM0, LPM1) Supply Currents Into V_{CC} Excluding External Current

over recommended operating free-air temperature (unless otherwise noted)^{(1) (2)}

PARAMETER	V _{CC}	FREQUENCY (f _{SMCLK})										UNIT
		1 MHz		4 MHz		8 MHz		12 MHz		16 MHz		
		TYP	MAX	TYP	MAX	TYP	MAX	TYP	MAX	TYP	MAX	
I _{LPM0}	2.2 V	75		105		165		240		220		μA
	3.0 V	85	135	115		175		250		240	290	
I _{LPM1}	2.2 V	40		65		130		215		195		μA
	3.0 V	40	67	65		130		215		195	222	

(1) All inputs are tied to 0 V or to V_{CC}. Outputs do not source or sink any current.

(2) Current for watchdog timer clocked by SMCLK included.

f_{ACLK} = 32768 Hz, f_{MCLK} = 0 MHz, f_{SMCLK} = f_{DCO} at specified frequency - except for 12 MHz: here f_{DCO}=24MHz and f_{SMCLK} = f_{DCO} / 2.

8.7 Low-Power Mode (LPM2, LPM3, LPM4) Supply Currents (Into V_{CC}) Excluding External Current

over recommended ranges of supply voltage and operating free-air temperature (unless otherwise noted) ⁽¹⁾ (see [Figure 8-2](#) and [Figure 8-3](#))

PARAMETER	V_{CC}	-40°C		25°C		60°C		85°C		UNIT
		TYP	MAX	TYP	MAX	TYP	MAX	TYP	MAX	
$I_{LPM2,XT12}$ Low-power mode 2, 12-pF crystal ⁽²⁾ (3) (4)	2.2 V	0.8		1.3		4.1		10.8		μA
	3.0 V	0.8		1.3		4.1		10.8		
$I_{LPM2,XT3.7}$ Low-power mode 2, 3.7-pF crystal ⁽²⁾ (5) (4)	2.2 V	0.6		1.2		4.0		10.7		μA
	3.0 V	0.6		1.2		4.0		10.7		
$I_{LPM2,VLO}$ Low-power mode 2, VLO, includes SVS ⁽⁶⁾	2.2 V	0.5		1.0		3.8		10.5		μA
	3.0 V	0.5		1.0		3.8		10.5		
$I_{LPM3,XT12}$ Low-power mode 3, 12-pF crystal, includes SVS ⁽²⁾ (3) (7)	2.2 V	0.8		1.0		2.2		4.5		μA
	3.0 V	0.8		1.0		2.2		4.5		
$I_{LPM3,XT3.7}$ Low-power mode 3, 3.7-pF crystal, excludes SVS ⁽²⁾ (5) (8) (also see Figure 8-2)	2.2 V	0.5		0.7		2.1		4.4		μA
	3.0 V	0.5		0.7		2.1		4.4		
$I_{LPM3,VLO}$ Low-power mode 3, VLO, excludes SVS ⁽⁹⁾	2.2 V	0.4		0.5		1.9		4.2		μA
	3.0 V	0.4		0.5		1.9		4.2		
$I_{LPM3,VLO, RAMoff}$ Low-power mode 3, VLO, excludes SVS, RAM powered down completely ⁽⁹⁾	2.2 V	0.36		0.47		1.4		2.6		μA
	3.0 V	0.36		0.47		1.4		2.6		
$I_{LPM4,SVS}$ Low-power mode 4, includes SVS ⁽¹⁰⁾	2.2 V	0.5		0.6		1.9		4.3		μA
	3.0 V	0.5		0.6		1.9		4.3		
I_{LPM4} Low-power mode 4, excludes SVS ⁽¹¹⁾	2.2 V	0.3		0.4		1.7		4.0		μA
	3.0 V	0.3		0.4		1.7		4.0		
$I_{LPM4,RAMoff}$ Low-power mode 4, excludes SVS, RAM powered down completely ⁽¹¹⁾	2.2 V	0.3		0.37		1.2		2.5		μA
	3.0 V	0.3		0.37		1.2		2.5		
$I_{IDLE,GroupA}$ Additional idle current if one or more modules from Group A (see Table 9-3) are activated in LPM3 or LPM4	3.0 V			0.02				0.3		μA
$I_{IDLE,GroupB}$ Additional idle current if one or more modules from Group B (see Table 9-3) are activated in LPM3 or LPM4	3.0 V			0.02				0.35		μA
$I_{IDLE,GroupC}$ Additional idle current if one or more modules from Group C (see Table 9-3) are activated in LPM3 or LPM4	3.0 V			0.02				0.38		μA

- (1) All inputs are tied to 0 V or to V_{CC} . Outputs do not source or sink any current.
- (2) Not applicable for devices with HF crystal oscillator only.
- (3) Characterized with a Micro Crystal MS1V-T1K crystal with a load capacitance of 12.5 pF. The internal and external load capacitance are chosen to closely match the required 12.5 pF load.
- (4) Low-power mode 2, crystal oscillator test conditions:
Current for watchdog timer clocked by ACLK and RTC clocked by XT1 included. Current for brownout and SVS included.
CPUOFF = 1, SCG0 = 0 SCG1 = 1, OSCOFF = 0 (LPM2),
 $f_{XT1} = 32768$ Hz, $f_{ACLK} = f_{XT1}$, $f_{MCLK} = f_{SMCLK} = 0$ MHz
- (5) Characterized with a Seiko SSP-T7-FL (SMD) crystal with a load capacitance of 3.7 pF. The internal and external load capacitance are chosen to closely match the required 3.7-pF load.
- (6) Low-power mode 2, VLO test conditions:
Current for watchdog timer clocked by ACLK included. RTC disabled (RTCHOLD = 1). Current for brownout and SVS included.
CPUOFF = 1, SCG0 = 0 SCG1 = 1, OSCOFF = 0 (LPM2),
 $f_{XT1} = 0$ Hz, $f_{ACLK} = f_{VLO}$, $f_{MCLK} = f_{SMCLK} = 0$ MHz
- (7) Low-power mode 3, 12-pF crystal including SVS test conditions:
Current for watchdog timer clocked by ACLK and RTC clocked by XT1 included. Current for brownout and SVS included (SVSHE = 1).
CPUOFF = 1, SCG0 = 1 SCG1 = 1, OSCOFF = 0 (LPM3),

$f_{XT1} = 32768 \text{ Hz}$, $f_{ACLK} = f_{XT1}$, $f_{MCLK} = f_{SMCLK} = 0 \text{ MHz}$

Activating additional peripherals increases the current consumption due to active supply current contribution and due to additional idle current. See the idle currents specified for the respective peripheral groups.

- (8) Low-power mode 3, 3.7-pF crystal excluding SVS test conditions:
Current for watchdog timer clocked by ACLK and RTC clocked by XT1 included. Current for brownout included. SVS disabled (SVSHE = 0).
CPUOFF = 1, SCG0 = 1 SCG1 = 1, OSCOFF = 0 (LPM3),
 $f_{XT1} = 32768 \text{ Hz}$, $f_{ACLK} = f_{XT1}$, $f_{MCLK} = f_{SMCLK} = 0 \text{ MHz}$
Activating additional peripherals increases the current consumption due to active supply current contribution and due to additional idle current. See the idle currents specified for the respective peripheral groups.
- (9) Low-power mode 3, VLO excluding SVS test conditions:
Current for watchdog timer clocked by ACLK included. RTC disabled (RTCHOLD = 1). RAM disabled (RCCTL0 = 5A55h). Current for brownout included. SVS disabled (SVSHE = 0).
CPUOFF = 1, SCG0 = 1 SCG1 = 1, OSCOFF = 0 (LPM3),
 $f_{XT1} = 0 \text{ Hz}$, $f_{ACLK} = f_{VLO}$, $f_{MCLK} = f_{SMCLK} = 0 \text{ MHz}$
Activating additional peripherals increases the current consumption due to active supply current contribution and due to additional idle current. See the idle currents specified for the respective peripheral groups.
- (10) Low-power mode 4 including SVS test conditions:
Current for brownout and SVS included (SVSHE = 1).
CPUOFF = 1, SCG0 = 1 SCG1 = 1, OSCOFF = 1 (LPM4),
 $f_{XT1} = 0 \text{ Hz}$, $f_{ACLK} = 0 \text{ Hz}$, $f_{MCLK} = f_{SMCLK} = 0 \text{ MHz}$
Activating additional peripherals increases the current consumption due to active supply current contribution and due to additional idle current. See the idle currents specified for the respective peripheral groups.
- (11) Low-power mode 4 excluding SVS test conditions:
Current for brownout included. SVS disabled (SVSHE = 0). RAM disabled (RCCTL0 = 5A55h).
CPUOFF = 1, SCG0 = 1 SCG1 = 1, OSCOFF = 1 (LPM4),
 $f_{XT1} = 0 \text{ Hz}$, $f_{ACLK} = 0 \text{ Hz}$, $f_{MCLK} = f_{SMCLK} = 0 \text{ MHz}$
Activating additional peripherals increases the current consumption due to active supply current contribution and due to additional idle current. See the idle currents specified for the respective peripheral groups.

8.8 Low-Power Mode (LPMx.5) Supply Currents (Into V_{CC}) Excluding External Current

over recommended ranges of supply voltage and operating free-air temperature (unless otherwise noted)⁽¹⁾(see [Figure 8-4](#) and [Figure 8-5](#))

PARAMETER	V _{CC}	-40°C		25°C		60°C		85°C		UNIT
		TYP	MAX	TYP	MAX	TYP	MAX	TYP	MAX	
I _{LPM3.5,XT12} Low-power mode 3.5, 12-pF crystal including SVS ^{(2) (3) (4)}	2.2 V	0.45		0.5		0.55		0.75		μA
	3.0 V	0.45		0.5		0.55		0.75		
I _{LPM3.5,XT3.7} Low-power mode 3.5, 3.7-pF crystal excluding SVS ^{(2) (5) (6)}	2.2 V	0.3		0.35		0.4		0.65		μA
	3.0 V	0.3		0.35		0.4		0.65		
I _{LPM4.5,SVS} Low-power mode 4.5, including SVS ⁽⁷⁾	2.2 V	0.23		0.25		0.28		0.4		μA
	3.0 V	0.23		0.25		0.28		0.4		
I _{LPM4.5} Low-power mode 4.5, excluding SVS ⁽⁸⁾	2.2 V	0.035		0.045		0.075		0.15		μA
	3.0 V	0.035		0.045		0.075		0.15		

- (1) All inputs are tied to 0 V or to VCC. Outputs do not source or sink any current
- (2) Not applicable for devices with HF crystal oscillator only.
- (3) Characterized with a Micro Crystal MS1V-T1K crystal with a load capacitance of 12.5 pF. The internal and external load capacitance are chosen to closely match the required 12.5 pF load.
- (4) Low-power mode 3.5, 1-pF crystal including SVS test conditions:
Current for RTC clocked by XT1 included. Current for brownout and SVS included (SVSHE = 1). Core regulator disabled.
PMMREGOFF = 1; CPUOFF = 1, SCG0 = 1 SCG1 = 1, OSCOFF = 1 (LPMx.5),
f_{XT1} = 32768 Hz, f_{ACLK} = f_{XT1}, f_{MCLK} = f_{SMCLK} = 0 MHz
- (5) Characterized with a Seiko SSP-T7-FL (SMD) crystal with a load capacitance of 3.7 pF. The internal and external load capacitance are chosen to closely match the required 3.7-pF load.
- (6) Low-power mode 3.5, 3.7-pF crystal excluding SVS test conditions:
Current for RTC clocked by XT1 included. Current for brownout included. SVS disabled (SVSHE = 0). Core regulator disabled.
PMMREGOFF = 1; CPUOFF = 1, SCG0 = 1 SCG1 = 1, OSCOFF = 1 (LPMx.5),
f_{XT1} = 32768 Hz, f_{ACLK} = f_{XT1}, f_{MCLK} = f_{SMCLK} = 0 MHz
- (7) Low-power mode 4.5 including SVS test conditions:
Current for brownout and SVS included (SVSHE = 1). Core regulator disabled.
PMMREGOFF = 1; CPUOFF = 1, SCG0 = 1 SCG1 = 1, OSCOFF = 1 (LPMx.5),
f_{XT1} = 0 Hz, f_{ACLK} = 0 Hz, f_{MCLK} = f_{SMCLK} = 0 MHz
- (8) Low-power mode 4.5 excluding SVS test conditions:
Current for brownout included. SVS disabled (SVSHE = 0). Core regulator disabled.
PMMREGOFF = 1; CPUOFF = 1, SCG0 = 1 SCG1 = 1, OSCOFF = 1 (LPMx.5),
f_{XT1} = 0 Hz, f_{ACLK} = 0 Hz, f_{MCLK} = f_{SMCLK} = 0 MHz

8.9 Typical Characteristics, Low-Power Mode Supply Currents

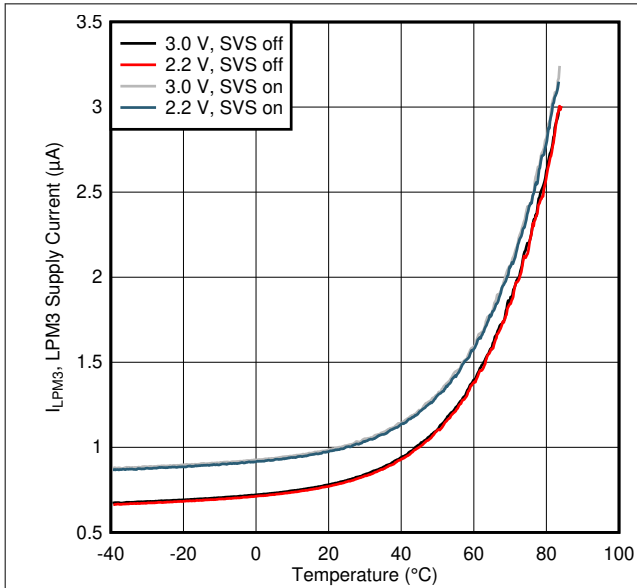

Figure 8-2. LPM3 Supply Current vs Temperature

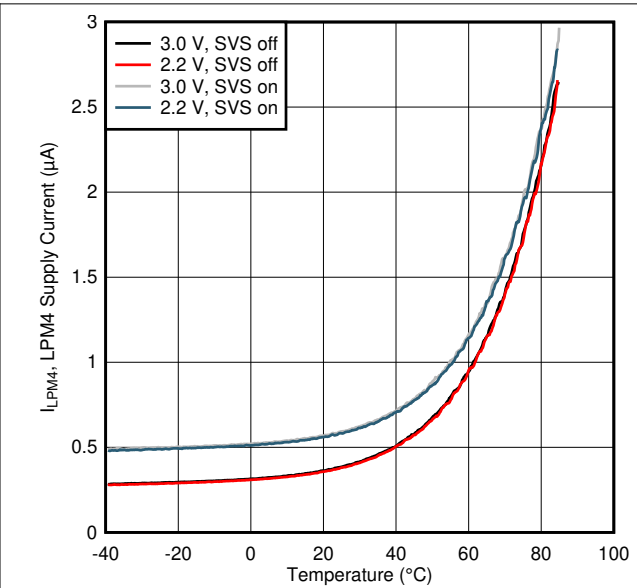

Figure 8-3. LPM4 Supply Current vs Temperature

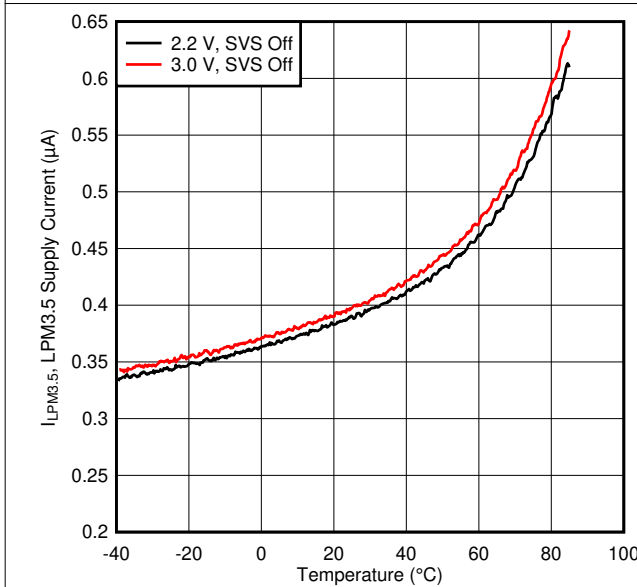

Figure 8-4. LPM3.5 Supply Current vs Temperature

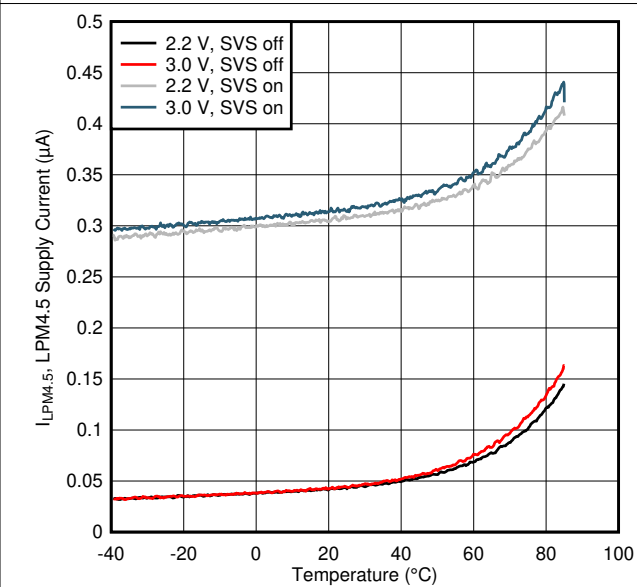

Figure 8-5. LPM4.5 Supply Current vs Temperature

8.10 Typical Characteristics, Current Consumption per Module

MODULE	TEST CONDITIONS ⁽¹⁾	REFERENCE CLOCK	MIN	TYP	MAX	UNIT
Timer_A		Module input clock		3		μA/MHz
Timer_B		Module input clock		5		μA/MHz
eUSCI_A	UART mode	Module input clock		6.3		μA/MHz
eUSCI_A	SPI mode	Module input clock		4		μA/MHz
eUSCI_B	SPI mode	Module input clock		4		μA/MHz
eUSCI_B	I ² C mode, 100 kbaud	Module input clock		4		μA/MHz
RTC_C		32 kHz		100		nA
MPY	Only from start to end of operation	MCLK		28		μA/MHz
CRC16	Only from start to end of operation	MCLK		3.3		μA/MHz
CRC32	Only from start to end of operation	MCLK		3.3		μA/MHz
LEA	256 Point Complex FFT, Data = nonzero	MCLK		86		μA/MHz
	256 Point Complex FFT, Data = zero			66		

(1) For other module currents not listed here, see the module-specific parameter sections.

8.11 Thermal Packaging Characteristics

THERMAL METRIC ^{(1) (2)}		PACKAGE	VALUE	UNIT
R _{θJA}	Junction-to-ambient thermal resistance, still air	QFN-48 (RGZ)	27.5	°C/W
R _{θJC(TOP)}	Junction-to-case (top) thermal resistance		12.5	°C/W
R _{θJB}	Junction-to-board thermal resistance		4.4	°C/W
Ψ _{JB}	Junction-to-board thermal characterization parameter		4.4	°C/W
Ψ _{JT}	Junction-to-top thermal characterization parameter		0.2	°C/W
R _{θJC(BOTTOM)}	Junction-to-case (bottom) thermal resistance		0.8	°C/W
R _{θJA}	Junction-to-ambient thermal resistance, still air	QFP-64 (PM)	53.2	°C/W
R _{θJC(TOP)}	Junction-to-case (top) thermal resistance		14.3	°C/W
R _{θJB}	Junction-to-board thermal resistance		24.7	°C/W
Ψ _{JB}	Junction-to-board thermal characterization parameter		24.4	°C/W
Ψ _{JT}	Junction-to-top thermal characterization parameter		0.6	°C/W
R _{θJA}	Junction-to-ambient thermal resistance, still air	QFP-80 (PN)	47.9	°C/W
R _{θJC(TOP)}	Junction-to-case (top) thermal resistance		13.0	°C/W
R _{θJB}	Junction-to-board thermal resistance		22.5	°C/W
Ψ _{JB}	Junction-to-board thermal characterization parameter		22.2	°C/W
Ψ _{JT}	Junction-to-top thermal characterization parameter		0.6	°C/W
R _{θJA}	Junction-to-ambient thermal resistance, still air	BGA-87 (ZVW)	60.6	°C/W
R _{θJC(TOP)}	Junction-to-case (top) thermal resistance		18.1	°C/W
R _{θJB}	Junction-to-board thermal resistance		31.8	°C/W
Ψ _{JB}	Junction-to-board thermal characterization parameter		30.1	°C/W
Ψ _{JT}	Junction-to-top thermal characterization parameter		0.7	°C/W

(1) For more information about traditional and new thermal metrics, see [Semiconductor and IC Package Thermal Metrics](#).

(2) These values are based on a JEDEC-defined 2S2P system (with the exception of the Theta JC (R_{θJC}) value, which is based on a JEDEC-defined 1S0P system) and will change based on environment and application. For more information, see these EIA/JEDEC standards:

- JESD51-2, *Integrated Circuits Thermal Test Method Environmental Conditions - Natural Convection (Still Air)*
- JESD51-3, *Low Effective Thermal Conductivity Test Board for Leaded Surface Mount Packages*
- JESD51-7, *High Effective Thermal Conductivity Test Board for Leaded Surface Mount Packages*
- JESD51-9, *Test Boards for Area Array Surface Mount Package Thermal Measurements*

8.12 Timing and Switching Characteristics

8.12.1 Power Supply Sequencing

TI recommends powering AVCC and DVCC pins from the same source. At a minimum, during power up, power down, and device operation, the voltage difference between AVCC and DVCC must not exceed the limits specified in [Section 8.1](#). Exceeding the specified limits may cause malfunction of the device including erroneous writes to RAM and FRAM.

[Section 8.12.1.1](#) lists the power ramp requirements.

8.12.1.1 Brownout and Device Reset Power Ramp Requirements

over recommended ranges of supply voltage and operating free-air temperature (unless otherwise noted)

PARAMETER		TEST CONDITIONS	MIN	MAX	UNIT
V _{VCC_BOR-}	Brownout power-down level ⁽¹⁾	dDV _{CC} /dt < 3 V/s	0.73	1.66	V
V _{VCC_BOR+}	Brownout power-up level ⁽¹⁾	dDV _{CC} /dt < 3 V/s ⁽²⁾	0.79	1.75	V

- (1) Fast supply voltage changes can trigger a BOR reset even within the recommended supply voltage range. To avoid unwanted BOR resets, the supply voltage must change by less than 0.05 volts per microsecond (± 0.05 V/ μ s). Following the data sheet recommendation for capacitor C_{DVCC} should limit the slopes accordingly.
- (2) The brownout levels are measured with a slowly changing supply.

[Section 8.12.1.2](#) lists the supply voltage supervisor characteristics.

8.12.1.2 SVS

over recommended ranges of supply voltage and operating free-air temperature (unless otherwise noted)

PARAMETER		TEST CONDITIONS	MIN	TYP	MAX	UNIT
I _{SVSH_LPM}	SVS _H current consumption, low power modes			170	300	nA
V _{SVSH-}	SVS _H power-down level ⁽¹⁾		1.75	1.80	1.85	V
V _{SVSH+}	SVS _H power-up level ⁽¹⁾		1.77	1.88	1.99	V
V _{SVSH_hys}	SVS _H hysteresis		40		150	mV
t _{PD,SVSH,AM}	SVS _H propagation delay, active mode	dV _{VCC} /dt = -10 mV/ μ s			10	μ s

- (1) For additional information, see the [Dynamic Voltage Scaling Power Solution for MSP430 Devices With Single-Channel LDO Reference Design](#).

8.12.2 Reset Timing

[Section 8.12.2.1](#) lists the input requirements of the reset pin.

8.12.2.1 Reset Input

over recommended ranges of supply voltage and operating free-air temperature (unless otherwise noted)

		V _{CC}	MIN	MAX	UNIT
t _(RST)	External reset pulse duration on $\overline{\text{RST}}$ ⁽¹⁾	2.2 V, 3.0 V	2		μ s

- (1) Not applicable if $\overline{\text{RST}}$ /NMI pin configured as NMI.

8.12.3 Clock Specifications

LFXTCLK (see [Section 8.12.3.1](#)) is a low-frequency oscillator that can be used either with low-frequency 32768-Hz watch crystals, standard crystals, resonators, or external clock sources in the 50 kHz or below range. When in bypass mode, LFXTCLK can be driven with an external square-wave signal.

8.12.3.1 Low-Frequency Crystal Oscillator, LFXT

over recommended ranges of supply voltage and operating free-air temperature (unless otherwise noted)

PARAMETER ⁽¹⁾	TEST CONDITIONS	V _{CC}	MIN	TYP	MAX	UNIT
I _{VCC,LFXT} Current consumption	f _{OSC} = 32768 Hz, LFXTBYPASS = 0, LFXTDRIVE = {0}, T _A = 25°C, C _{L,eff} = 3.7 pF, ESR ≈ 44 kΩ	3.0 V		180		nA
	f _{OSC} = 32768 Hz, LFXTBYPASS = 0, LFXTDRIVE = {1}, T _A = 25°C, C _{L,eff} = 6 pF, ESR ≈ 40 kΩ			185		
	f _{OSC} = 32768 Hz, LFXTBYPASS = 0, LFXTDRIVE = {2}, T _A = 25°C, C _{L,eff} = 9 pF, ESR ≈ 40 kΩ			225		
	f _{OSC} = 32768 Hz, LFXTBYPASS = 0, LFXTDRIVE = {3}, T _A = 25°C, C _{L,eff} = 12.5 pF, ESR ≈ 40 kΩ			330		
f _{LFXT} LFXT oscillator crystal frequency	LFXTBYPASS = 0			32768		Hz
DC _{LFXT} LFXT oscillator duty cycle	Measured at ACLK, f _{LFXT} = 32768 Hz		30%		70%	
f _{LFXT,SW} LFXT oscillator logic-level square-wave input frequency	LFXTBYPASS = 1 ^{(2) (3)}		10.5	32.768	50	kHz
DC _{LFXT, SW} LFXT oscillator logic-level square-wave input duty cycle	LFXTBYPASS = 1		30%		70%	
O _{A,LFXT} Oscillation allowance for LF crystals ⁽⁴⁾	LFXTBYPASS = 0, LFXTDRIVE = {1}, f _{LFXT} = 32768 Hz, C _{L,eff} = 6 pF			210		kΩ
	LFXTBYPASS = 0, LFXTDRIVE = {3}, f _{LFXT} = 32768 Hz, C _{L,eff} = 12.5 pF			300		
C _{LFXIN} Integrated load capacitance at LFXIN terminal ^{(5) (6)}				2		pF
C _{LFXOUT} Integrated load capacitance at LFXOUT terminal ^{(5) (6)}				2		pF
t _{START,LFXT} Start-up time ⁽⁷⁾	f _{OSC} = 32768 Hz LFXTBYPASS = 0, LFXTDRIVE = {0}, T _A = 25°C, C _{L,eff} = 3.7 pF,	3.0 V		800		ms
	f _{OSC} = 32768 Hz LFXTBYPASS = 0, LFXTDRIVE = {3}, T _A = 25°C, C _{L,eff} = 12.5 pF	3.0 V		1000		
f _{Fault,LFXT} Oscillator fault frequency ^{(8) (9)}			0		3500	Hz

- (1) To improve EMI on the LFXT oscillator, the following guidelines should be observed.
 - Keep the trace between the device and the crystal as short as possible.
 - Design a good ground plane around the oscillator pins.
 - Prevent crosstalk from other clock or data lines into oscillator pins LFXIN and LFXOUT.
 - Avoid running PCB traces underneath or adjacent to the LFXIN and LFXOUT pins.
 - Use assembly materials and processes that avoid any parasitic load on the oscillator LFXIN and LFXOUT pins.
 - If conformal coating is used, ensure that it does not induce capacitive or resistive leakage between the oscillator pins.
- (2) When LFXTBYPASS is set, LFXT circuits are automatically powered down. Input signal is a digital square wave with parametrics defined in the Schmitt-trigger Inputs section of this datasheet. Duty cycle requirements are defined by DC_{LFXT, SW}.
- (3) Maximum frequency of operation of the entire device cannot be exceeded.
- (4) Oscillation allowance is based on a safety factor of 5 for recommended crystals. The oscillation allowance is a function of the LFXTDRIVE settings and the effective load. In general, comparable oscillator allowance can be achieved based on the following guidelines, but should be evaluated based on the actual crystal selected for the application:

- For LFXTDRIVE = {0}, $C_{L,eff} = 3.7 \text{ pF}$
 - For LFXTDRIVE = {1}, $C_{L,eff} = 6 \text{ pF}$
 - For LFXTDRIVE = {2}, $6 \text{ pF} \leq C_{L,eff} \leq 9 \text{ pF}$
 - For LFXTDRIVE = {3}, $9 \text{ pF} \leq C_{L,eff} \leq 12.5 \text{ pF}$
- (5) This represents all the parasitic capacitance present at the LFXIN and LFXOUT terminals, respectively, including parasitic bond and package capacitance. The effective load capacitance, $C_{L,eff}$ can be computed as $C_{IN} \times C_{OUT} / (C_{IN} + C_{OUT})$, where C_{IN} and C_{OUT} are the total capacitance at the LFXIN and LFXOUT terminals, respectively.
 - (6) Requires external capacitors at both terminals to meet the effective load capacitance specified by crystal manufacturers. Recommended effective load capacitance values supported are 3.7 pF, 6 pF, 9 pF, and 12.5 pF. Maximum shunt capacitance of 1.6 pF. The PCB adds additional capacitance, so it must also be considered in the overall capacitance. Verify that the recommended effective load capacitance of the selected crystal is met.
 - (7) Includes startup counter of 1024 clock cycles.
 - (8) Frequencies above the MAX specification do not set the fault flag. Frequencies between the MIN and MAX specification may set the flag. A static condition or stuck at fault condition will set the flag.
 - (9) Measured with logic-level input frequency but also applies to operation with crystals.

HFXTCLK (see [Section 8.12.3.2](#)) is a high-frequency oscillator that can be used with standard crystals or resonators in the 4-MHz to 24-MHz range. When in bypass mode, HFXTCLK can be driven with an external square-wave signal.

8.12.3.2 High-Frequency Crystal Oscillator, HFXT

over recommended ranges of supply voltage and operating free-air temperature (unless otherwise noted)

PARAMETER ⁽¹⁾	TEST CONDITIONS	V _{CC}	MIN	TYP	MAX	UNIT
I _{DVCC,HFXT} HFXT oscillator crystal current HF mode at typical ESR	f _{OSC} = 4 MHz, HFXTBYPASS = 0, HFXTDRIVE = 0, HFFREQ = 1 ⁽²⁾ , T _A = 25°C, C _{L,eff} = 18 pF, typical ESR, C _{shunt}	3.0 V		75		μA
	f _{OSC} = 8 MHz, HFXTBYPASS = 0, HFXTDRIVE = 1, HFFREQ = 1, T _A = 25°C, C _{L,eff} = 18 pF, typical ESR, C _{shunt}			120		
	f _{OSC} = 16 MHz, HFXTBYPASS = 0, HFXTDRIVE = 2, HFFREQ = 2, T _A = 25°C C _{L,eff} = 18 pF, typical ESR, C _{shunt}			190		
	f _{OSC} = 24 MHz HFXTBYPASS = 0, HFXTDRIVE = 3, HFFREQ = 3, T _A = 25°C C _{L,eff} = 18 pF, typical ESR, C _{shunt}			250		
f _{HFXT} HFXT oscillator crystal frequency, crystal mode	HFXTBYPASS = 0, HFFREQ = 1 ⁽²⁾ ⁽³⁾		4		8	MHz
	HFXTBYPASS = 0, HFFREQ = 2 ⁽³⁾		8.01		16	
	HFXTBYPASS = 0, HFFREQ = 3 ⁽³⁾		16.01		24	
DC _{HFXT} HFXT oscillator duty cycle.	Measured at SMCLK, f _{HFXT} = 16 MHz		40%	50%	60%	
f _{HFXT,SW} HFXT oscillator logic-level square-wave input frequency, bypass mode	HFXTBYPASS = 1, HFFREQ = 0 ⁽⁴⁾ ⁽³⁾		0.9		4	MHz
	HFXTBYPASS = 1, HFFREQ = 1 0 ⁽⁴⁾ ⁽³⁾		4.01		8	
	HFXTBYPASS = 1, HFFREQ = 20 ⁽⁴⁾ ⁽³⁾		8.01		16	
	HFXTBYPASS = 1, HFFREQ = 3 0 ⁽⁴⁾ ⁽³⁾		16.01		24	
DC _{HFXT, SW} HFXT oscillator logic-level square-wave input duty cycle	HFXTBYPASS = 1		40%		60%	

8.12.3.2 High-Frequency Crystal Oscillator, HFXT (continued)

over recommended ranges of supply voltage and operating free-air temperature (unless otherwise noted)

PARAMETER ⁽¹⁾		TEST CONDITIONS	V _{CC}	MIN	TYP	MAX	UNIT
O _{A,HFXT}	Oscillation allowance for HFXT crystals ⁽⁵⁾	HFXTBYPASS = 0, HFXTDRIVE = 0, HFFREQ = 1 ⁽²⁾ , f _{HFXT,HF} = 4 MHz, C _{L,eff} = 16 pF			450		Ω
		HFXTBYPASS = 0, HFXTDRIVE = 1, HFFREQ = 1, f _{HFXT,HF} = 8 MHz, C _{L,eff} = 16 pF			320		
		HFXTBYPASS = 0, HFXTDRIVE = 2, HFFREQ = 2, f _{HFXT,HF} = 16 MHz, C _{L,eff} = 16 pF			200		
		HFXTBYPASS = 0, HFXTDRIVE = 3, HFFREQ = 3, f _{HFXT,HF} = 24 MHz, C _{L,eff} = 16 pF			200		
t _{START,HFXT}	Startup time ⁽⁶⁾	f _{OSC} = 4 MHz, HFXTBYPASS = 0, HFXTDRIVE = 0, HFFREQ = 1, T _A = 25°C, C _{L,eff} = 16 pF	3.0 V		1.6		ms
		f _{OSC} = 24 MHz, HFXTBYPASS = 0, HFXTDRIVE = 3, HFFREQ = 3, T _A = 25°C, C _{L,eff} = 16 pF			0.6		
C _{HFXIN}	Integrated load capacitance at HFXIN terminal ^{(7) (8)}				2		pF
C _{HFXOUT}	Integrated load capacitance at HFXOUT terminal ^{(7) (8)}				2		pF
f _{Fault,HFXT}	Oscillator fault frequency ^{(9) (10)}			0		800	kHz

- (1) To improve EMI on the HFXT oscillator the following guidelines should be observed.
 - Keep the traces between the device and the crystal as short as possible.
 - Design a good ground plane around the oscillator pins.
 - Prevent crosstalk from other clock or data lines into oscillator pins HFXIN and HFXOUT.
 - Avoid running PCB traces underneath or adjacent to the HFXIN and HFXOUT pins.
 - Use assembly materials and processes that avoid any parasitic load on the oscillator HFXIN and HFXOUT pins.
 - If conformal coating is used, ensure that it does not induce capacitive or resistive leakage between the oscillator pins.
- (2) HFFREQ = {0} is not supported for HFXT crystal mode of operation.
- (3) Maximum frequency of operation of the entire device cannot be exceeded.
- (4) When HFXTBYPASS is set, HFXT circuits are automatically powered down. Input signal is a digital square wave with parametrics defined in the Schmitt-trigger Inputs section of this datasheet. Duty cycle requirements are defined by DC_{HFXT, SW}.
- (5) Oscillation allowance is based on a safety factor of 5 for recommended crystals.
- (6) Includes startup counter of 1024 clock cycles.
- (7) This represents all the parasitic capacitance present at the HFXIN and HFXOUT terminals, respectively, including parasitic bond and package capacitance. The effective load capacitance, C_{L,eff} can be computed as C_{IN} × C_{OUT} / (C_{IN} + C_{OUT}), where C_{IN} and C_{OUT} is the total capacitance at the HFXIN and HFXOUT terminals, respectively.
- (8) Requires external capacitors at both terminals to meet the effective load capacitance specified by crystal manufacturers. Recommended effective load capacitance values supported are 14 pF, 16 pF, and 18 pF. Maximum shunt capacitance of 7 pF. The PCB adds additional capacitance, so it must also be considered in the overall capacitance. Verify that the recommended effective load capacitance of the selected crystal is met.
- (9) Frequencies above the MAX specification do not set the fault flag. Frequencies between the MIN and MAX might set the flag. A static condition or stuck at fault condition will set the flag.
- (10) Measured with logic-level input frequency but also applies to operation with crystals.

The DCO (see Section 8.12.3.3) is an internal digitally controlled oscillator (DCO) with selectable frequencies.

8.12.3.3 DCO

over recommended ranges of supply voltage and operating free-air temperature (unless otherwise noted)

PARAMETER		TEST CONDITIONS	V _{CC}	MIN	TYP	MAX	UNIT
f _{DCO1}	DCO frequency range 1 MHz, trimmed	Measured at SMCLK, divide by 1, DCORSEL = 0, DCOFSEL = 0, DCORSEL = 1, DCOFSEL = 0			1	±3.5%	MHz
f _{DCO2.7}	DCO frequency range 2.7 MHz, trimmed	Measured at SMCLK, divide by 1, DCORSEL = 0, DCOFSEL = 1			2.667	±3.5%	MHz
f _{DCO3.5}	DCO frequency range 3.5 MHz, trimmed	Measured at SMCLK, divide by 1, DCORSEL = 0, DCOFSEL = 2			3.5	±3.5%	MHz
f _{DCO4}	DCO frequency range 4 MHz, trimmed	Measured at SMCLK, divide by 1 DCORSEL = 0, DCOFSEL = 3			4	±3.5%	MHz
f _{DCO5.3}	DCO frequency range 5.3 MHz, trimmed	Measured at SMCLK, divide by 1, DCORSEL = 0, DCOFSEL = 4, DCORSEL = 1, DCOFSEL = 1			5.333	±3.5%	MHz
f _{DCO7}	DCO frequency range 7 MHz, trimmed	Measured at SMCLK, divide by 1, DCORSEL = 0, DCOFSEL = 5, DCORSEL = 1, DCOFSEL = 2			7	±3.5%	MHz
f _{DCO8}	DCO frequency range 8 MHz, trimmed	Measured at SMCLK, divide by 1, DCORSEL = 0, DCOFSEL = 6, DCORSEL = 1, DCOFSEL = 3			8	±3.5%	MHz
f _{DCO16}	DCO frequency range 16 MHz, trimmed	Measured at SMCLK, divide by 1, DCORSEL = 1, DCOFSEL = 4			16	±3.5%	MHz
f _{DCO21}	DCO frequency range 21 MHz, trimmed	Measured at SMCLK, divide by 2, DCORSEL = 1, DCOFSEL = 5			21	±3.5%	MHz
f _{DCO24}	DCO frequency range 24 MHz, trimmed	Measured at SMCLK, divide by 2, DCORSEL = 1, DCOFSEL = 6			24	±3.5%	MHz
f _{DCO,DC}	Duty cycle	Measured at SMCLK, divide by 1, No external divide, all DCORSEL and DCOFSEL settings except DCORSEL = 1 with DCOFSEL = 5, and DCORSEL = 1 with DCOFSEL = 6		48%	50%	52%	
t _{DCO, JITTER}	DCO jitter	Based on f _{signal} = 10 kHz and DCO used for 12-bit SAR ADC sampling source. This achieves greater than 74-dB SNR due to jitter (that is, limited by ADC performance).			2	3	ns
df _{DCO} /dT	DCO temperature drift ⁽¹⁾		3.0 V		0.01		%/°C

(1) Calculated using the box method: (MAX(−40°C to 85°C) - MIN(−40°C to 85°C)) / MIN(−40°C to 85°C) / (85°C - (−40°C))

8.12.3.4 Internal Very-Low-Power Low-Frequency Oscillator (VLO)

over recommended ranges of supply voltage and operating free-air temperature (unless otherwise noted)

PARAMETER		TEST CONDITIONS	V _{CC}	MIN	TYP	MAX	UNIT
I _{VLO}	Current consumption				100		nA
f _{VLO}	VLO frequency ⁽¹⁾	Measured at ACLK		6	9.4	14	kHz
df _{VLO} /dT	VLO frequency temperature drift	Measured at ACLK ⁽²⁾			0.2		%/°C
df _{VLO} /dV _{CC}	VLO frequency supply voltage drift	Measured at ACLK ⁽³⁾			0.7		%/V
f _{VLO,DC}	Duty cycle	Measured at ACLK		40%	50%	60%	

(1) VLO frequency may decrease in LPM3 or LPM4 mode. The typical ratio of VLO frequencies (LPM3/4 to AM) is 85%.

(2) Calculated using the box method: (MAX(−40°C to 85°C) - MIN(−40°C to 85°C)) / MIN(−40°C to 85°C) / (85°C - (−40°C))

(3) Calculated using the box method: (MAX(1.8 V to 3.6 V) - MIN(1.8 V to 3.6 V)) / MIN(1.8 V to 3.6 V) / (3.6 V - 1.8 V)

The module oscillator (MODOSC) is an internal low-power oscillator with 5-MHz typical frequency (see [Section 8.12.3.5](#)).

8.12.3.5 Module Oscillator (MODOSC)

over recommended ranges of supply voltage and operating free-air temperature (unless otherwise noted)

PARAMETER		TEST CONDITIONS	MIN	TYP	MAX	UNIT
I_{MODOSC}	Current consumption	Enabled		25		μA
f_{MODOSC}	MODOSC frequency		4.0	4.8	5.4	MHz
f_{MODOSC}/dT	MODOSC frequency temperature drift ⁽¹⁾			0.08		%/°C
f_{MODOSC}/dV_{CC}	MODOSC frequency supply voltage drift ⁽²⁾			1.4		%/V
DC_{MODOSC}	Duty cycle	Measured at SMCLK, divide by 1	40%	50%	60%	

(1) Calculated using the box method: $(MAX(-40^{\circ}C \text{ to } 85^{\circ}C) - MIN(-40^{\circ}C \text{ to } 85^{\circ}C)) / MIN(-40^{\circ}C \text{ to } 85^{\circ}C) / (85^{\circ}C - (-40^{\circ}C))$

(2) Calculated using the box method: $(MAX(1.8 \text{ V to } 3.6 \text{ V}) - MIN(1.8 \text{ V to } 3.6 \text{ V})) / MIN(1.8 \text{ V to } 3.6 \text{ V}) / (3.6 \text{ V} - 1.8 \text{ V})$

8.12.4 Wake-up Characteristics

[Section 8.12.4.1](#) lists the wake-up times.

8.12.4.1 Wake-up Times From Low-Power Modes and Reset

over recommended ranges of supply voltage and operating free-air temperature (unless otherwise noted) (see [Figure 8-6](#) and [Figure 8-7](#))

PARAMETER		TEST CONDITIONS	V_{CC}	MIN	TYP	MAX	UNIT
$t_{WAKE-UP \text{ FRAM}}$	(Additional) wake-up time to activate the FRAM in AM if previously disabled by the FRAM controller or from an LPM if immediate activation is selected for wakeup				6	10	μs
$t_{WAKE-UP \text{ LPM0}}$	Wake-up time from LPM0 to active mode ⁽¹⁾		2.2 V, 3.0 V			400 ns + 1.5 / f_{DCO}	
$t_{WAKE-UP \text{ LPM1}}$	Wake-up time from LPM1 to active mode ⁽¹⁾		2.2 V, 3.0 V		6		μs
$t_{WAKE-UP \text{ LPM2}}$	Wake-up time from LPM2 to active mode ⁽¹⁾		2.2 V, 3.0 V		6		μs
$t_{WAKE-UP \text{ LPM3}}$	Wake-up time from LPM3 to active mode ⁽¹⁾		2.2 V, 3.0 V		6.6 + 2.0 / f_{DCO}	9.6 + 2.5 / f_{DCO}	μs
$t_{WAKE-UP \text{ LPM4}}$	Wake-up time from LPM4 to active mode ⁽¹⁾		2.2 V, 3.0 V		6.6 + 2.0 / f_{DCO}	9.6 + 2.5 / f_{DCO}	μs
$t_{WAKE-UP \text{ LPM3.5}}$	Wake-up time from LPM3.5 to active mode ⁽²⁾		2.2 V, 3.0 V		250	350	μs
$t_{WAKE-UP \text{ LPM4.5}}$	Wake-up time from LPM4.5 to active mode ⁽²⁾	SVSHE = 1	2.2 V, 3.0 V		250	350	μs
		SVSHE = 0	2.2 V, 3.0 V		0.4	0.8	ms
$t_{WAKE-UP \text{ RST}}$	Wake-up time from a \overline{RST} pin triggered reset to active mode ⁽²⁾		2.2 V, 3.0 V		300	403	μs
$t_{WAKE-UP \text{ BOR}}$	Wake-up time from power-up to active mode ⁽²⁾		2.2 V, 3.0 V		0.5	1	ms

(1) The wake-up time is measured from the edge of an external wake-up signal (for example, port interrupt or wake-up event) to the first externally observable MCLK clock edge with MCLKREQEN = 1. This time includes the activation of the FRAM during wake up. With MCLKREQEN = 0, the externally observable MCLK clock is gated one additional cycle.

(2) The wake-up time is measured from the edge of an external wake-up signal (for example, port interrupt or wake-up event) until the first instruction of the user program is executed.

8.12.4.2 Typical Characteristics, Average LPM Currents vs Wake-up Frequency

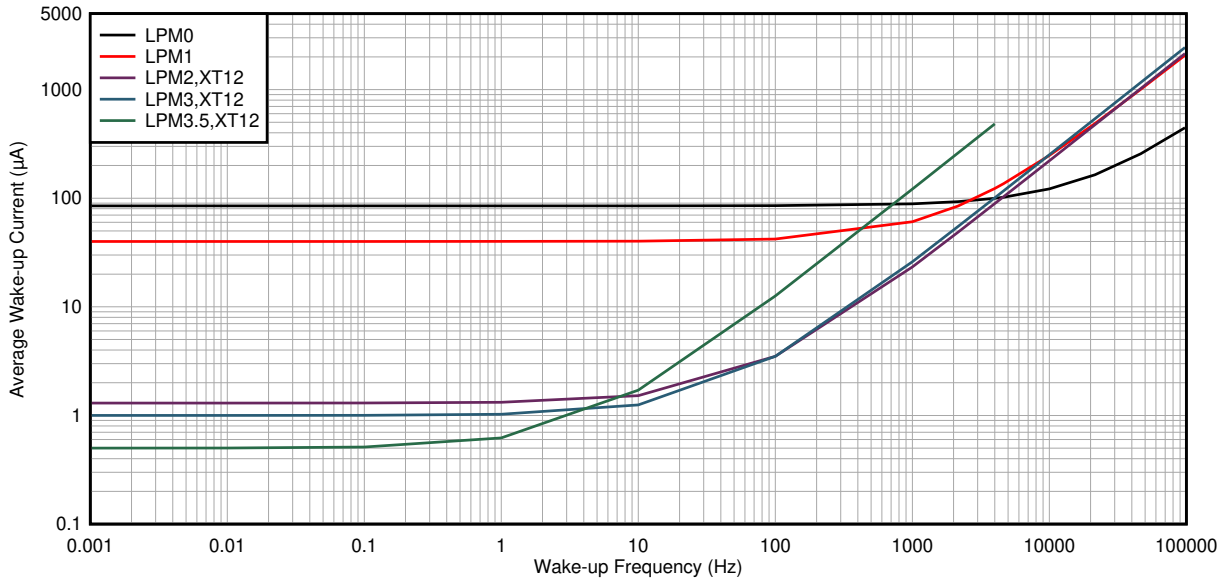

The average wake-up current does not include the energy required in active mode; for example, for an interrupt service routine (ISR) or to reconfigure the device.

Figure 8-6. Average LPM Currents vs Wake-up Frequency at 25°C

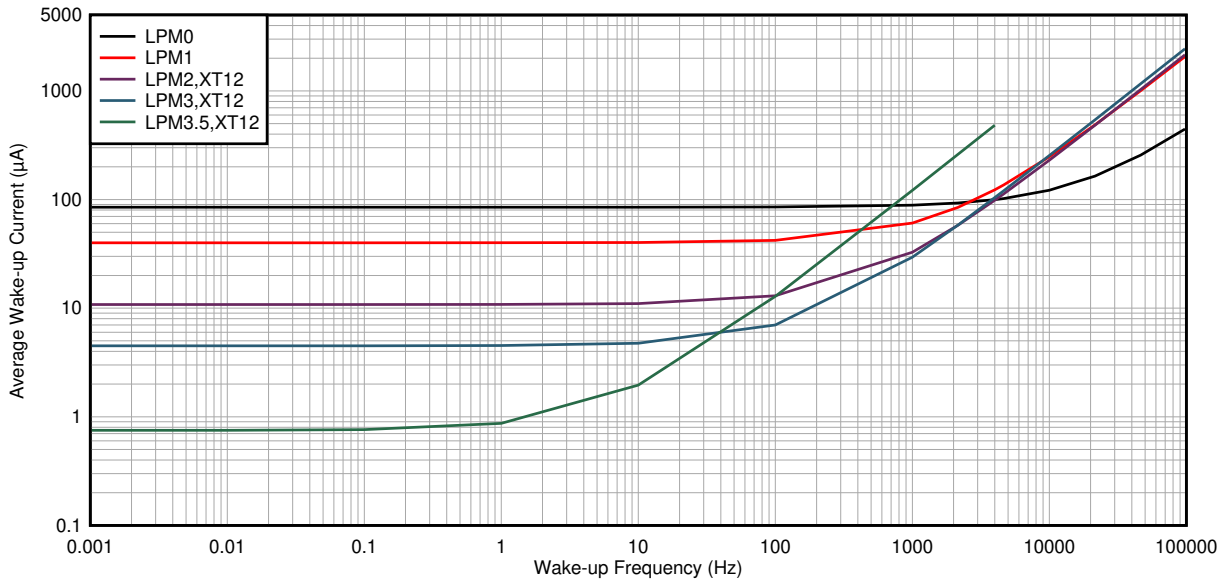

The average wake-up current does not include the energy required in active mode; for example, for an ISR or to reconfigure the device.

Figure 8-7. Average LPM Currents vs Wake-up Frequency at 85°C

8.12.4.3 Typical Wake-up Charge

Section 8.12.4.3 lists the typical charge required to wake up from LPM or reset.

PARAMETER ⁽¹⁾		TEST CONDITIONS	MIN	TYP	MAX	UNIT
Q _{WAKE-UP FRAM}	Charge used for activating the FRAM in AM or during wake-up from LPM0 if previously disabled by the FRAM controller.			16.5		nAs
Q _{WAKE-UP LPM0}	Charge used for wake-up from LPM0 to active mode (with FRAM active)			3.8		nAs
Q _{WAKE-UP LPM1}	Charge used for wake-up from LPM1 to active mode (with FRAM active)			21		nAs
Q _{WAKE-UP LPM2}	Charge used for wake-up from LPM2 to active mode (with FRAM active)			22		nAs
Q _{WAKE-UP LPM3}	Charge used for wake-up from LPM3 to active mode (with FRAM active)			25		nAs
Q _{WAKE-UP LPM4}	Charge used for wake-up from LPM4 to active mode (with FRAM active)			25		nAs
Q _{WAKE-UP LPM3.5}	Charge used for wake-up from LPM3.5 to active mode ⁽²⁾			121		nAs
Q _{WAKE-UP LPM4.5}	Charge used for wake-up from LPM4.5 to active mode ⁽²⁾	SVSHE = 1		123		nAs
		SVSHE = 0		121		
Q _{WAKE-UP-RESET}	Charge used for reset from RST or BOR event to active mode ⁽²⁾			102		nAs

- (1) Charge used during the wake-up time from a given low-power mode to active mode. This does not include the energy required in active mode (for example, for an ISR).
- (2) Charge required until start of user code. This does not include the energy required to reconfigure the device.

8.12.5 Digital I/Os

Section 8.12.5.1 lists the characteristics of the digital inputs.

8.12.5.1 Digital Inputs

over recommended ranges of supply voltage and operating free-air temperature (unless otherwise noted)

PARAMETER		TEST CONDITIONS	V _{CC}	MIN	TYP	MAX	UNIT
V _{IT+}	Positive-going input threshold voltage		2.2 V	1.2		1.65	V
			3.0 V	1.65		2.25	
V _{IT-}	Negative-going input threshold voltage		2.2 V	0.55		1.00	V
			3.0 V	0.75		1.35	
V _{hys}	Input voltage hysteresis (V _{IT+} – V _{IT-})		2.2 V	0.44		0.98	V
			3.0 V	0.60		1.30	
R _{Pull}	Pullup or pulldown resistor	For pullup: V _{IN} = V _{SS} , For pulldown: V _{IN} = V _{CC}		20	35	50	kΩ
C _{I,dig}	Input capacitance, digital only port pins	V _{IN} = V _{SS} or V _{CC}			3		pF
C _{I,ana}	Input capacitance, port pins with shared analog functions ⁽¹⁾	V _{IN} = V _{SS} or V _{CC}			5		pF
I _{lkg(Px.y)}	High-impedance input leakage current	See ⁽²⁾ ⁽³⁾	2.2 V, 3.0 V	-20		+20	nA
t _(int)	External interrupt timing (external trigger pulse duration to set interrupt flag) ⁽⁴⁾	Ports with interrupt capability (see the Functional Block Diagram and Signal Descriptions)	2.2 V, 3.0 V	20			ns
t _(RST)	External reset pulse duration on $\overline{\text{RST}}$ ⁽⁵⁾		2.2 V, 3.0 V	2			μs

- (1) If the port pins PJ.4/LFXIN and PJ.5/LFXOUT are used as digital I/Os, they are connected by a 4-pF capacitor and a 35-MΩ resistor in series. At frequencies of approximately 1 kHz and lower, the 4-pF capacitor can add to the pin capacitance of PJ.4/LFXIN and/or PJ.5/LFXOUT.
- (2) The input leakage current is measured with V_{SS} or V_{CC} applied to the corresponding pins, unless otherwise noted.
- (3) The input leakage of the digital port pins is measured individually. The port pin is selected for input and the pullup or pulldown resistor is disabled.
- (4) An external signal sets the interrupt flag every time the minimum interrupt pulse duration t_(int) is met. It may be set by trigger signals shorter than t_(int).
- (5) Not applicable if RST/NMI pin configured as NMI .

Section 8.12.5.2 lists the characteristics of the digital outputs.

8.12.5.2 Digital Outputs

over recommended ranges of supply voltage and operating free-air temperature (unless otherwise noted)

PARAMETER	TEST CONDITIONS	V _{CC}	MIN	TYP	MAX	UNIT
V _{OH} High-level output voltage (see Figure 8-10 and Figure 8-11)	I _(OHmax) = -1 mA ⁽¹⁾	2.2 V	V _{CC} - 0.25		V _{CC}	V
	I _(OHmax) = -3 mA ⁽²⁾		V _{CC} - 0.60		V _{CC}	
	I _(OHmax) = -2 mA ⁽¹⁾	3.0 V	V _{CC} - 0.25		V _{CC}	
	I _(OHmax) = -6 mA ⁽²⁾		V _{CC} - 0.60		V _{CC}	
V _{OL} Low-level output voltage (see Figure 8-8 and Figure 8-9)	I _(OLmax) = 1 mA ⁽¹⁾	2.2 V	V _{SS}		V _{SS} + 0.25	V
	I _(OLmax) = 3 mA ⁽²⁾		V _{SS}		V _{SS} + 0.60	
	I _(OLmax) = 2 mA ⁽¹⁾	3.0 V	V _{SS}		V _{SS} + 0.25	
	I _(OLmax) = 6 mA ⁽²⁾		V _{SS}		V _{SS} + 0.60	
f _{Px,y} Port output frequency (with load) ⁽³⁾	C _L = 20 pF, R _L ⁽⁴⁾ ⁽⁵⁾	2.2 V	16			MHz
		3.0 V	16			
f _{Port_CLK} Clock output frequency ⁽³⁾	ACLK, MCLK, or SMCLK at configured output port, C _L = 20 pF ⁽⁵⁾	2.2 V	16			MHz
		3.0 V	16			
t _{rise,dig} Port output rise time, digital only port pins	C _L = 20 pF	2.2 V		4	15	ns
		3.0 V		3	15	
t _{fall,dig} Port output fall time, digital only port pins	C _L = 20 pF	2.2 V		4	15	ns
		3.0 V		3	15	
t _{rise,ana} Port output rise time, port pins with shared analog functions	C _L = 20 pF	2.2 V		6	15	ns
		3.0 V		4	15	
t _{fall,ana} Port output fall time, port pins with shared analog functions	C _L = 20 pF	2.2 V		6	15	ns
		3.0 V		4	15	

- (1) The maximum total current, I_(OHmax) and I_(OLmax), for all outputs combined should not exceed ±48 mA to hold the maximum voltage drop specified.
- (2) The maximum total current, I_(OHmax) and I_(OLmax), for all outputs combined should not exceed ±100 mA to hold the maximum voltage drop specified.
- (3) The port can output frequencies at least up to the specified limit, and it might support higher frequencies.
- (4) A resistive divider with 2 × R1 and R1 = 1.6 kΩ between V_{CC} and V_{SS} is used as load. The output is connected to the center tap of the divider. C_L = 20 pF is connected from the output to V_{SS}.
- (5) The output voltage reaches at least 10% and 90% V_{CC} at the specified toggle frequency.

8.12.5.3 Typical Characteristics, Digital Outputs at 3.0 V and 2.2 V

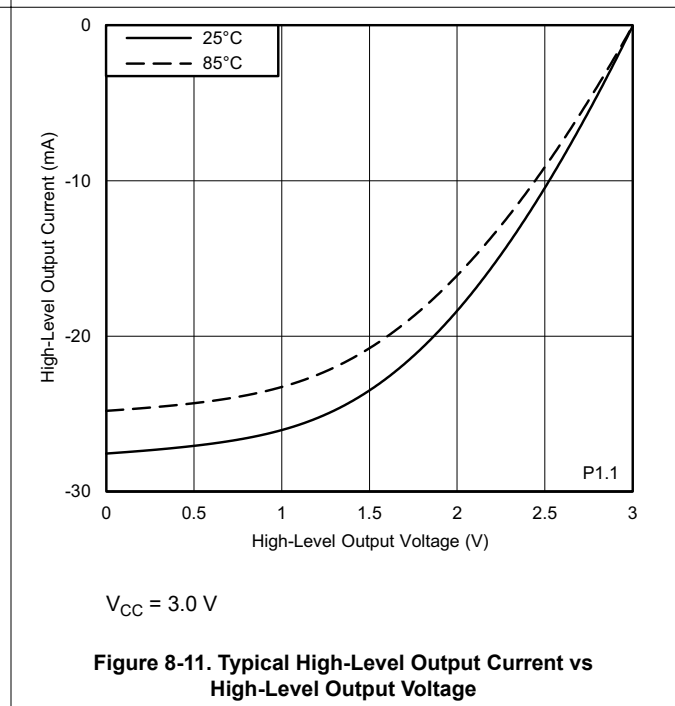
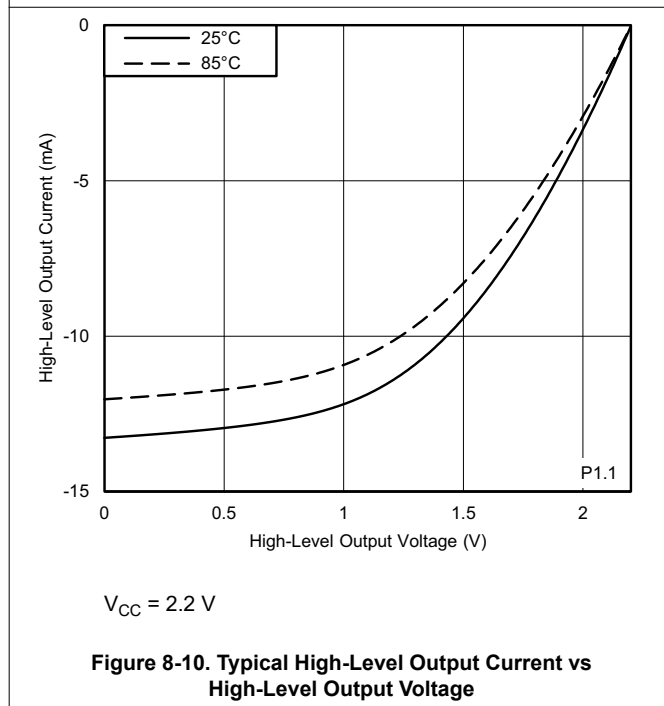
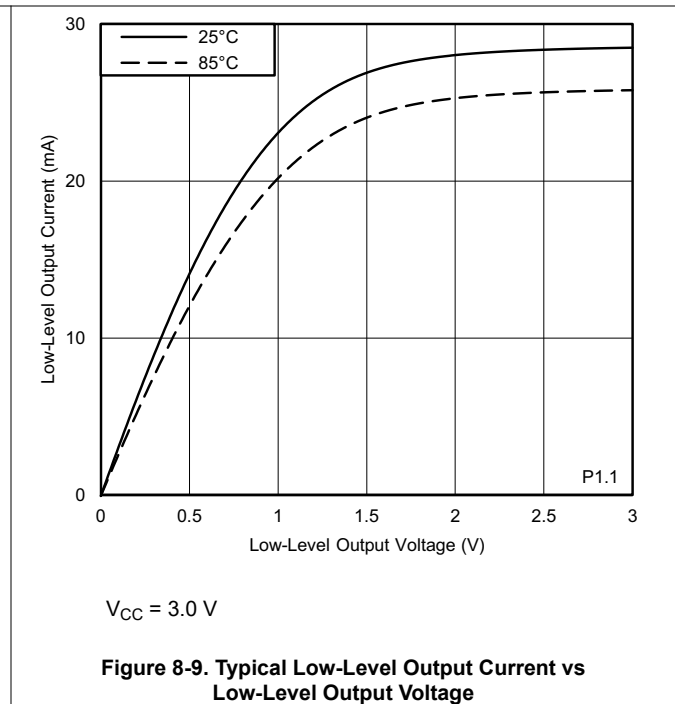
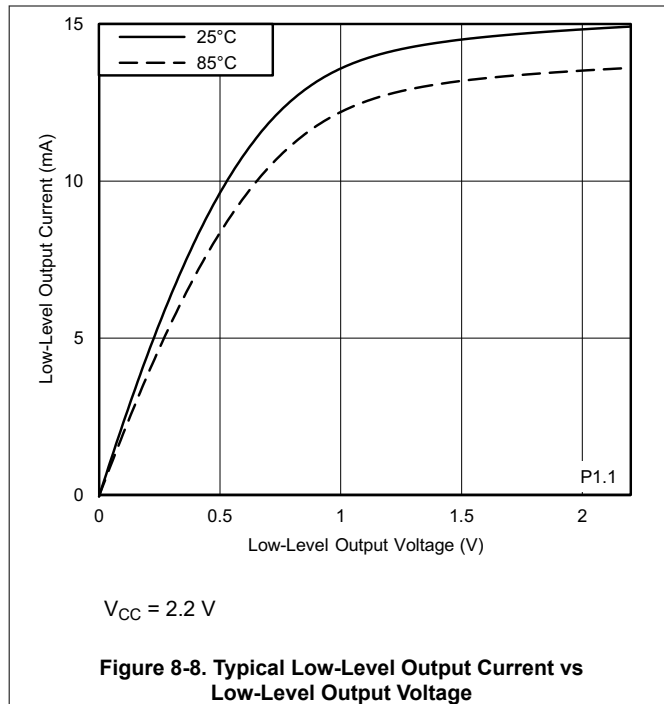

8.12.5.4 Pin-Oscillator Frequency, Ports Px

over recommended ranges of supply voltage and operating free-air temperature (unless otherwise noted)

PARAMETER		TEST CONDITIONS	V_{CC}	MIN	TYP	MAX	UNIT
$f_{oPx,y}$	Pin-oscillator frequency (see Figure 8-12 and Figure 8-13)	Px.y, $C_L = 10\text{ pF}^{(1)}$	3.0 V		1200		kHz
		Px.y, $C_L = 20\text{ pF}^{(1)}$	3.0 V		650		kHz

(1) C_L is the external load capacitance connected from the output to V_{SS} and includes all parasitic effects such as PCB traces.

8.12.5.5 Typical Characteristics, Pin-Oscillator Frequency

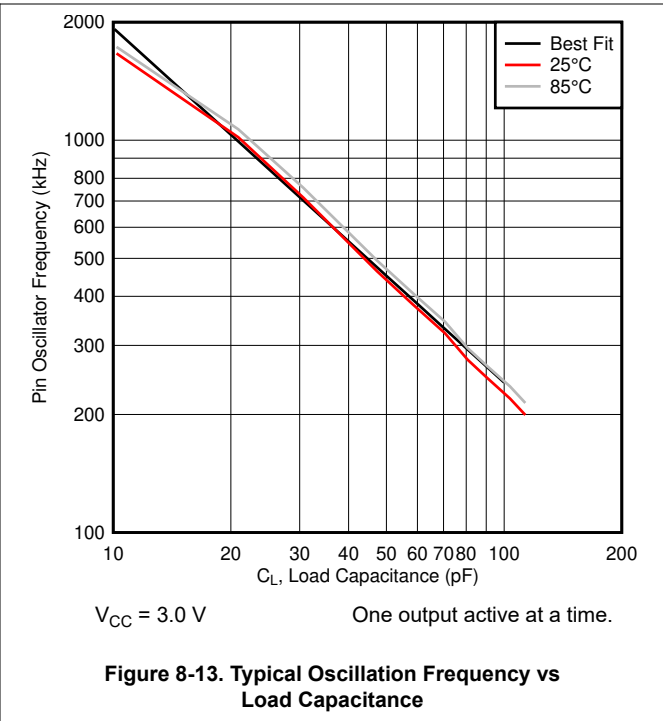
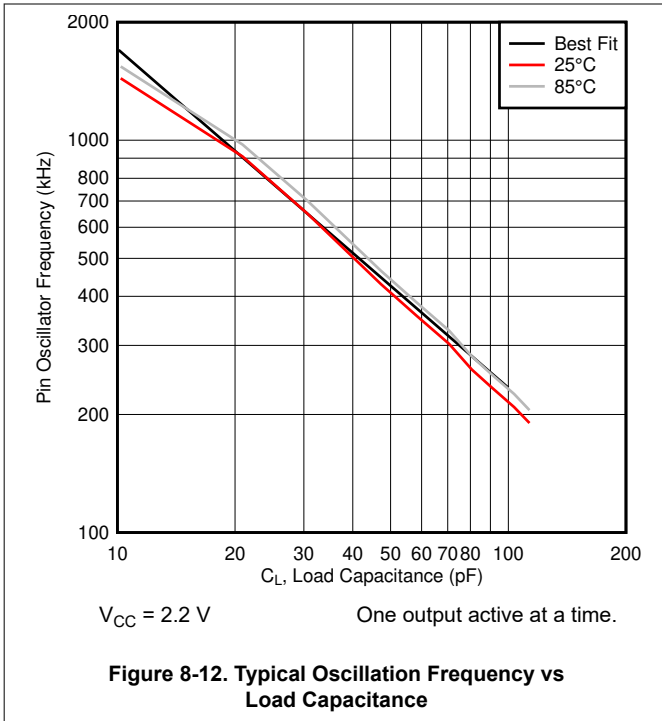

8.12.6 LEA (Low-Energy Accelerator) (MSP430FR599x Only)

The LEA module is a hardware engine designed for operations that involve vector-based signal processing. [Section 8.12.6.1](#) lists the performance characteristics of the LEA module.

8.12.6.1 Low Energy Accelerator Performance

over recommended ranges of supply voltage and operating free-air temperature (unless otherwise noted)

PARAMETER		TEST CONDITIONS		MIN	TYP	MAX	UNIT
f_{LEA}	Frequency for specified performance	MCLK			16		MHz
W_LEA_FFT	LEA subsystem energy on fast Fourier transform	Complex FFT 128-point Q.15 with random data in LEA-RAM	$V_{Core} = 3\text{ V}$, MCLK = 16 MHz		350		nJ
W_LEA_FIR	LEA subsystem energy on finite impulse response	Real FIR on random Q.31 data with 128 taps on 24 points	$V_{Core} = 3\text{ V}$, MCLK = 16 MHz		2.6		μJ
W_LEA_ADD	LEA subsystem energy on additions	On 32 Q.31 elements with random value out of LEA-RAM with linear address increment	$V_{Core} = 3\text{ V}$, MCLK = 16 MHz		6.6		nJ

8.12.7 Timer_A and Timer_B

Timer_A and Timer_B are 16-bit timers and counters with multiple capture/compare registers. [Section 8.12.7.1](#) lists the Timer_A characteristics, and [Section 8.12.7.2](#) lists the Timer_B characteristics.

8.12.7.1 Timer_A

over recommended ranges of supply voltage and operating free-air temperature (unless otherwise noted)

PARAMETER		TEST CONDITIONS	V_{CC}	MIN	MAX	UNIT
f_{TA}	Timer_A input clock frequency	Internal: SMCLK or ACLK, External: TACLK, Duty cycle = 50% \pm 10%	2.2 V, 3.0 V		16	MHz
$t_{TA,cap}$	Timer_A capture timing	All capture inputs, minimum pulse duration required for capture	2.2 V, 3.0 V	20		ns

8.12.7.2 Timer_B

over recommended ranges of supply voltage and operating free-air temperature (unless otherwise noted)

PARAMETER		TEST CONDITIONS	V_{CC}	MIN	MAX	UNIT
f_{TB}	Timer_B input clock frequency	Internal: SMCLK or ACLK, External: TBCLK, Duty cycle = 50% \pm 10%	2.2 V, 3.0 V		16	MHz
$t_{TB,cap}$	Timer_B capture timing	All capture inputs, minimum pulse duration required for capture	2.2 V, 3.0 V	20		ns

8.12.8 eUSCI

The enhanced universal serial communication interface (eUSCI) supports multiple serial communication modes with one hardware module. The eUSCI_A module supports UART and SPI modes. The eUSCI_B module supports I²C and SPI modes.

Section 8.12.8.1 lists the UART clock frequencies.

8.12.8.1 eUSCI (UART Mode) Clock Frequency

over recommended ranges of supply voltage and operating free-air temperature (unless otherwise noted)

PARAMETER		TEST CONDITIONS	MIN	MAX	UNIT
f _{eUSCI}	eUSCI input clock frequency	Internal: SMCLK or ACLK, External: UCLK, Duty cycle = 50% ±10%		16	MHz
f _{BITCLK}	BITCLK clock frequency (equals baud rate in MBaud)			4	MHz

Section 8.12.8.2 lists the UART operating characteristics.

8.12.8.2 eUSCI (UART Mode)

over recommended ranges of supply voltage and operating free-air temperature (unless otherwise noted)

PARAMETER		TEST CONDITIONS	V _{CC}	MIN	MAX	UNIT
t _t	UART receive deglitch time ⁽¹⁾	UCGLITx = 0	2.2 V, 3.0 V	5	30	ns
		UCGLITx = 1		20	90	
		UCGLITx = 2		35	160	
		UCGLITx = 3		50	220	

- (1) Pulses on the UART receive input (UCxRX) shorter than the UART receive deglitch time are suppressed. Thus the selected deglitch time can limit the maximum useable baud rate. To ensure that pulses are correctly recognized, their duration should exceed the maximum specification of the deglitch time.

Section 8.12.8.3 lists the SPI master mode clock frequencies.

8.12.8.3 eUSCI (SPI Master Mode) Clock Frequency

over recommended ranges of supply voltage and operating free-air temperature (unless otherwise noted)

PARAMETER		TEST CONDITIONS	MIN	MAX	UNIT
f_{eUSCI}	eUSCI input clock frequency	Internal: SMCLK or ACLK, Duty cycle = 50% \pm 10%		16	MHz

Section 8.12.8.4 lists the SPI master mode operating characteristics.

8.12.8.4 eUSCI (SPI Master Mode)

over recommended ranges of supply voltage and operating free-air temperature (unless otherwise noted)⁽¹⁾

PARAMETER		TEST CONDITIONS	V _{CC}	MIN	TYP	MAX	UNIT
$t_{STE,LEAD}$	STE lead time, STE active to clock	UCSTEM = 1, UCMODEx = 01 or 10		1			UCxCLK cycles
$t_{STE,LAG}$	STE lag time, Last clock to STE inactive	UCSTEM = 1, UCMODEx = 01 or 10		1			
$t_{STE,ACC}$	STE access time, STE active to SIMO data out	UCSTEM = 0, UCMODEx = 01 or 10	2.2 V, 3.0 V			60	ns
$t_{STE,DIS}$	STE disable time, STE inactive to SOMI high impedance	UCSTEM = 0, UCMODEx = 01 or 10	2.2 V, 3.0 V			80	ns
$t_{SU,MI}$	SOMI input data setup time		2.2 V	40			ns
			3.0 V	40			
$t_{HD,MI}$	SOMI input data hold time		2.2 V	0			ns
			3.0 V	0			
$t_{VALID,MO}$	SIMO output data valid time ⁽²⁾	UCLK edge to SIMO valid, C _L = 20 pF	2.2 V			11	ns
			3.0 V			10	
$t_{HD,MO}$	SIMO output data hold time ⁽³⁾	C _L = 20 pF	2.2 V		0		ns
			3.0 V		0		

- (1) $f_{UCxCLK} = 1/2 t_{LO/Hi}$ with $t_{LO/Hi} = \max(t_{VALID,MO}(eUSCI) + t_{SU,SI}(Slave), t_{SU,MI}(eUSCI) + t_{VALID,SO}(Slave))$
 For the slave parameters $t_{SU,SI}(Slave)$ and $t_{VALID,SO}(Slave)$, see the SPI parameters of the attached slave.
- (2) Specifies the time to drive the next valid data to the SIMO output after the output changing UCLK clock edge. See the timing diagrams in [Figure 8-14](#) and [Figure 8-15](#).
- (3) Specifies how long data on the SIMO output is valid after the output changing UCLK clock edge. Negative values indicate that the data on the SIMO output can become invalid before the output changing clock edge observed on UCLK. See the timing diagrams in [Figure 8-14](#) and [Figure 8-15](#).

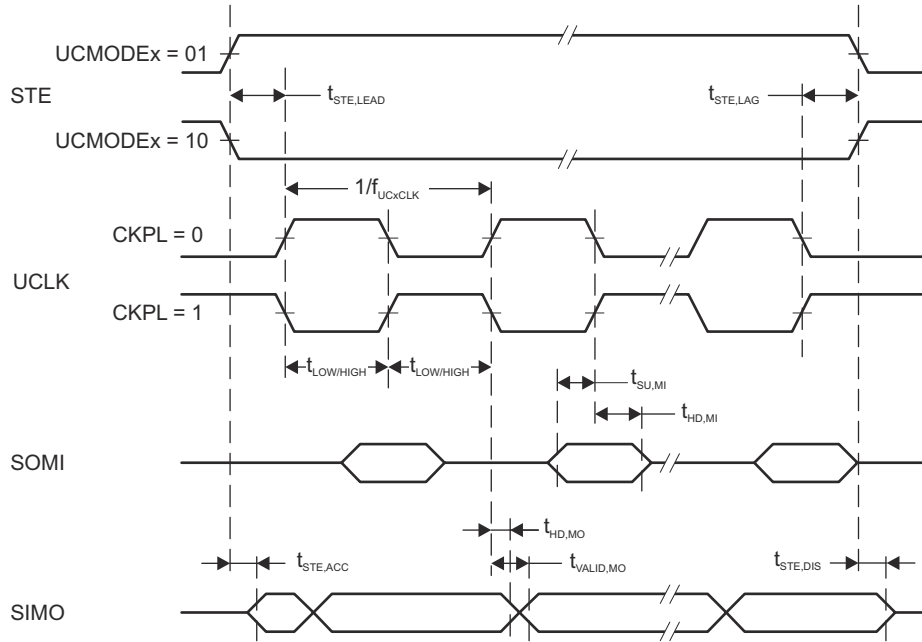

Figure 8-14. SPI Master Mode, CKPH = 0

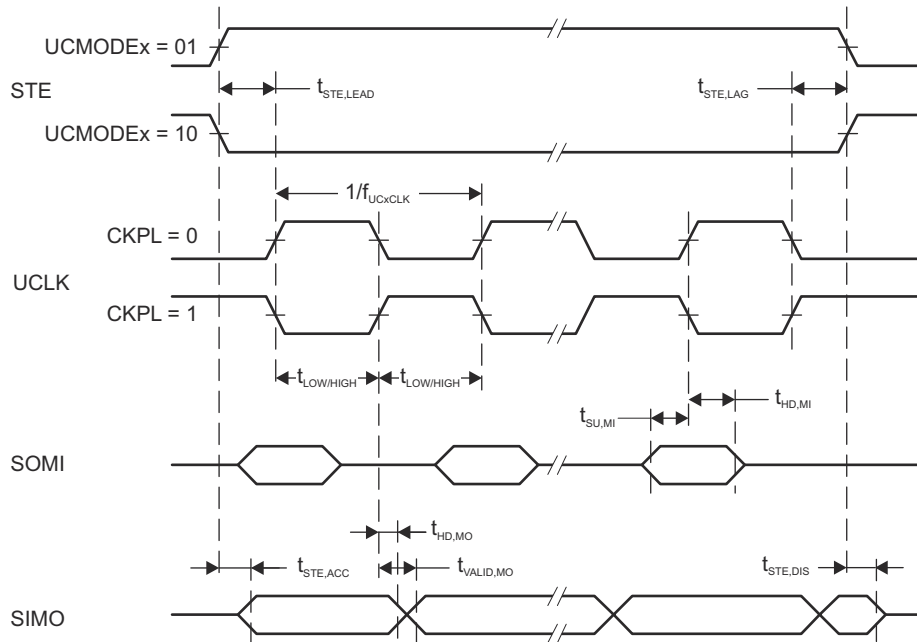

Figure 8-15. SPI Master Mode, CKPH = 1

Section 8.12.8.5 lists the SPI slave mode operating characteristics.

8.12.8.5 eUSCI (SPI Slave Mode)

over recommended ranges of supply voltage and operating free-air temperature (unless otherwise noted)⁽¹⁾

PARAMETER		TEST CONDITIONS	V _{CC}	MIN	MAX	UNIT
t _{STE,LEAD}	STE lead time, STE active to clock		2.2 V	45		ns
			3.0 V	40		
t _{STE,LAG}	STE lag time, Last clock to STE inactive		2.2 V	2		ns
			3.0 V	3		
t _{STE,ACC}	STE access time, STE active to SOMI data out		2.2 V		45	ns
			3.0 V		40	
t _{STE,DIS}	STE disable time, STE inactive to SOMI high impedance		2.2 V		50	ns
			3.0 V		45	
t _{SU,SI}	SIMO input data setup time		2.2 V	4		ns
			3.0 V	4		
t _{HD,SI}	SIMO input data hold time		2.2 V	7		ns
			3.0 V	7		
t _{VALID,SO}	SOMI output data valid time ⁽²⁾	UCLK edge to SOMI valid, C _L = 20 pF	2.2 V		35	ns
			3.0 V		35	
t _{HD,SO}	SOMI output data hold time ⁽³⁾	C _L = 20 pF	2.2 V	0		ns
			3.0 V	0		

- (1) $f_{UCXCLK} = 1/2 t_{LO/Hi}$ with $t_{LO/Hi} \geq \max(t_{VALID,MO(Master)} + t_{SU,SI(eUSCI)}, t_{SU,MI(Master)} + t_{VALID,SO(eUSCI)})$
 For the master parameters $t_{SU,MI(Master)}$ and $t_{VALID,MO(Master)}$, see the SPI parameters of the attached master.
- (2) Specifies the time to drive the next valid data to the SOMI output after the output changing UCLK clock edge. See the timing diagrams in [Figure 8-16](#) and [Figure 8-17](#).
- (3) Specifies how long data on the SOMI output is valid after the output changing UCLK clock edge. See the timing diagrams in [Figure 8-16](#) and [Figure 8-17](#).

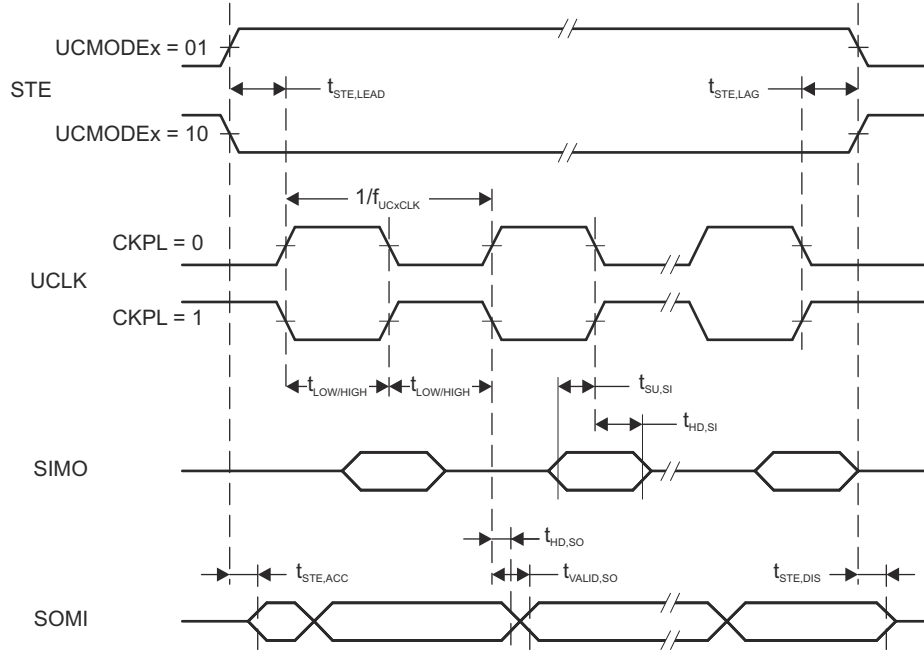

Figure 8-16. SPI Slave Mode, CKPH = 0

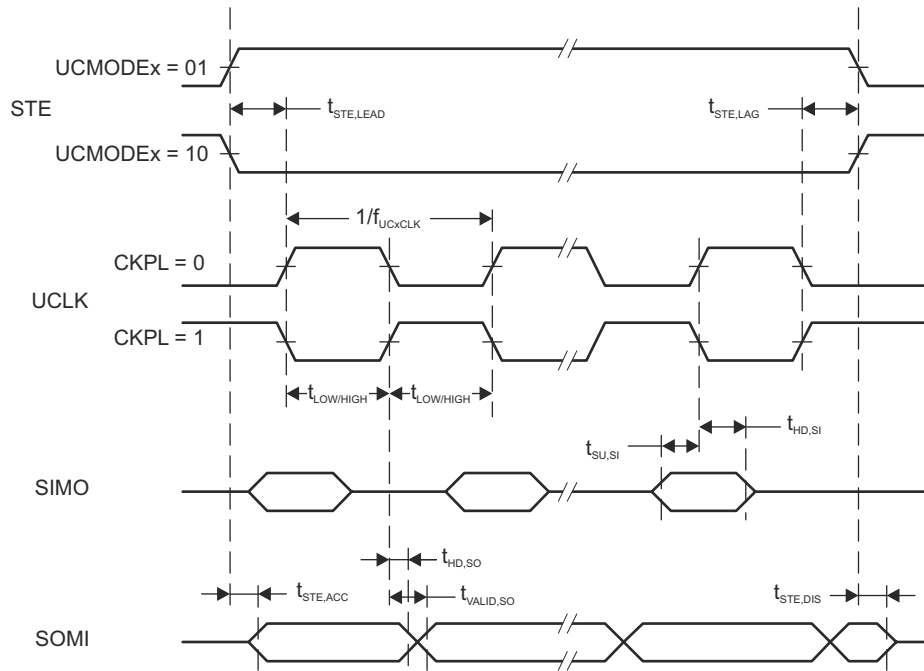

Figure 8-17. SPI Slave Mode, CKPH = 1

Section 8.12.8.6 lists the I²C mode operating characteristics.

8.12.8.6 eUSCI (I²C Mode)

over recommended ranges of supply voltage and operating free-air temperature (unless otherwise noted) (see Figure 8-18)

PARAMETER		TEST CONDITIONS	V _{CC}	MIN	TYP	MAX	UNIT
f _{eUSCI}	eUSCI input clock frequency	Internal: SMCLK or ACLK, External: UCLK, Duty cycle = 50% ±10%				16	MHz
f _{SCL}	SCL clock frequency		2.2 V, 3.0 V	0		400	kHz
t _{HD,STA}	Hold time (repeated) START	f _{SCL} = 100 kHz f _{SCL} > 100 kHz	2.2 V, 3.0 V	4.0 0.6			μs
t _{SU,STA}	Setup time for a repeated START	f _{SCL} = 100 kHz f _{SCL} > 100 kHz	2.2 V, 3.0 V	4.7 0.6			μs
t _{HD,DAT}	Data hold time		2.2 V, 3.0 V	0			ns
t _{SU,DAT}	Data setup time		2.2 V, 3.0 V	100			ns
t _{SU,STO}	Setup time for STOP	f _{SCL} = 100 kHz f _{SCL} > 100 kHz	2.2 V, 3.0 V	4.0 0.6			μs
t _{SP}	Pulse duration of spikes suppressed by input filter	UCGLITx = 0	2.2 V, 3.0 V	50		250	ns
		UCGLITx = 1		25	125		
		UCGLITx = 2		12.5	62.5		
		UCGLITx = 3		6.3	31.5		
t _{TIMEOUT}	Clock low time-out	UCCLTOx = 1	2.2 V, 3.0 V		27		ms
		UCCLTOx = 2			30		
		UCCLTOx = 3			33		

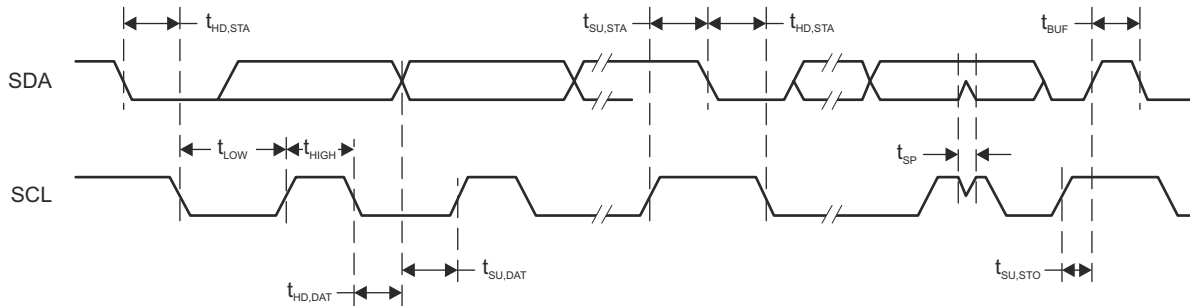

Figure 8-18. I²C Mode Timing

8.12.9 ADC12_B

The ADC12_B module supports fast 12-bit analog-to-digital conversions. The module implements a 12-bit SAR core, sample select control, and up to 32 independent conversion-and-control buffers. The conversion-and-control buffer allows up to 32 independent analog-to-digital converter (ADC) samples to be converted and stored without any CPU intervention.

Section 8.12.9.1 lists the power supply and input range conditions.

8.12.9.1 12-Bit ADC, Power Supply and Input Range Conditions

over recommended ranges of supply voltage and operating free-air temperature (unless otherwise noted)

PARAMETER		TEST CONDITIONS	V _{CC}	MIN	NOM	MAX	UNIT
V _(Ax)	Analog input voltage range ⁽¹⁾	All ADC12 analog input pins Ax		0		AVCC	V
I _(ADC12_B) single-ended mode	Operating supply current into AVCC plus DVCC terminals ^{(2) (3)}	f _{ADC12CLK} = MODCLK, ADC12ON = 1, ADC12PWRMD = 0, ADC12DIF = 0, REFON = 0, ADC12SHTx = 0, ADC12DIV = 0	3.0 V		145	199	μA
			2.2 V		140	190	
I _(ADC12_B) differential mode	Operating supply current into AVCC plus DVCC terminals ^{(2) (3)}	f _{ADC12CLK} = MODCLK, ADC12ON = 1, ADC12PWRMD = 0, ADC12DIF = 1, REFON = 0, ADC12SHTx = 0, ADC12DIV = 0	3.0 V		175	245	μA
			2.2 V		170	230	
I _(ADC12_B) single-ended low-power mode	Operating supply current into AVCC plus DVCC terminals ^{(2) (3)}	f _{ADC12CLK} = MODCLK / 4, ADC12ON = 1, ADC12PWRMD = 1, ADC12DIF = 0, REFON = 0, ADC12SHTx = 0, ADC12DIV = 0	3.0 V		85	125	μA
			2.2 V		83	120	
I _(ADC12_B) differential low-power mode	Operating supply current into AVCC plus DVCC terminals ^{(2) (3)}	f _{ADC12CLK} = MODCLK / 4, ADC12ON = 1, ADC12PWRMD = 1, ADC12DIF = 1, REFON = 0, ADC12SHTx = 0, ADC12DIV = 0	3.0 V		110	165	μA
			2.2 V		109	160	
C _i	Input capacitance	Only one terminal Ax can be selected at one time	2.2 V		10	15	pF
R _i	Input MUX ON-resistance	0 V ≤ V _(Ax) ≤ AV _{CC}	>2 V		0.5	4	kΩ
			<2 V		1	10	

- (1) The analog input voltage range must be within the selected reference voltage range V_{R+} to V_{R-} for valid conversion results.
- (2) The internal reference supply current is not included in current consumption parameter I_(ADC12_B).
- (3) Approximately 60% (typical) of the total current into the AVCC and DVCC terminals is from AVCC.

Section 8.12.9.2 lists the timing parameters.

8.12.9.2 12-Bit ADC, Timing Parameters

over recommended ranges of supply voltage and operating free-air temperature (unless otherwise noted)

PARAMETER		TEST CONDITIONS	MIN	TYP	MAX	UNIT
f _{ADC12CLK}	Frequency for specified performance	For specified performance of ADC12 linearity parameters with ADC12PWRMD = 0. If ADC12PWRMD = 1, the maximum is 1/4 of the value shown here.	0.45		5.4	MHz
f _{ADC12CLK}	Frequency for reduced performance	Linearity parameters have reduced performance		32.768		kHz
f _{ADC12OSC}	Internal oscillator ⁽³⁾	ADC12DIV = 0, f _{ADC12CLK} = f _{ADC12OSC} from MODCLK	4	4.8	5.4	MHz
t _{CONVERT}	Conversion time	REFON = 0, Internal oscillator, f _{ADC12CLK} = f _{ADC12OSC} from MODCLK, ADC12WINC = 0	2.6		3.5	μs
		External f _{ADC12CLK} from ACLK, MCLK, or SMCLK, ADC12SSEL ≠ 0		(2)		
t _{ADC12ON}	Turnon settling time of the ADC	See (1)			100	ns
t _{ADC12OFF}	Time ADC must be off before it can be turned on again	t _{ADC12OFF} must be met to make sure that t _{ADC12ON} time holds	100			ns
t _{Sample}	Sampling time	R _S = 400 Ω, R _I = 4 kΩ, C _I = 15 pF, C _{pext} = 8 pF ⁽⁴⁾	All pulse sample mode (ADC12SHP = 1) and extended sample mode (ADC12SHP = 0) with buffered reference (ADC12VRSEL = 0x1, 0x3, 0x5, 0x7, 0x9, 0xB, 0xD, 0xF)		1	μs
			Extended sample mode (ADC12SHP = 0) with unbuffered reference (ADC12VRSEL = 0x0, 0x2, 0x4, 0x6, 0xC, 0xE)		(5)	

- (1) The condition is that the error in a conversion started after t_{ADC12ON} is less than ±0.5 LSB. The reference and input signal are already settled.
- (2) 14 × 1 / f_{ADC12CLK}. If ADC12WINC = 1 then 15 × 1 / f_{ADC12CLK}
- (3) The ADC12OSC is sourced directly from MODOSC inside the UCS.
- (4) Approximately 10 Tau (τ) are needed to get an error of less than ±0.5 LSB: t_{sample} = ln(2ⁿ⁺²) × (R_S + R_I) × (C_I + C_{pext}), where n = ADC resolution = 12, R_S = external source resistance, C_{pext} = external parasitic capacitance.
- (5) 6 × 1/f_{ADC12CLK}

Section 8.12.9.3 lists the linearity parameters.

8.12.9.3 12-Bit ADC, Linearity Parameters

over recommended ranges of supply voltage and operating free-air temperature (unless otherwise noted)

PARAMETER		TEST CONDITIONS	MIN	TYP	MAX	UNIT
E _I	Integral linearity error (INL) for differential input	With external voltage reference (ADC12VRSEL = 0x2, 0x3, 0x4, 0x14, 0x15), 1.2 V ≤ (V _{R+} – V _{R-}) ≤ AV _{CC}			±1.8	LSB
	Integral linearity error (INL) for single-ended inputs				±2.2	
E _D	Differential linearity error (DNL)	With external voltage reference (ADC12VRSEL = 0x2, 0x3, 0x4, 0x14, 0x15)	-0.99		+1.0	LSB
E _O	Offset error ^{(1) (2)}	ADC12VRSEL = 0x1 without TLV calibration, TLV calibration data can be used to improve the parameter ⁽³⁾		±0.5	±1.5	mV
E _G	Gain error	With internal voltage reference VREF = 2.5 V (ADC12VRSEL = 0x1, 0x7, 0x9, 0xB, or 0xD)		±0.2%	±1.7%	LSB
		With internal voltage reference VREF = 1.2 V (ADC12VRSEL = 0x1, 0x7, 0x9, 0xB, or 0xD)		±0.2%	±2.5%	
		With external voltage reference without internal buffer (ADC12VRSEL = 0x2 or 0x4) without TLV calibration, V _{R+} = 2.5 V, V _{R-} = AVSS		±1	±3	
		With external voltage reference with internal buffer (ADC12VRSEL = 0x3), V _{R+} = 2.5 V, V _{R-} = AVSS		±2	±27	
E _T	Total unadjusted error	With internal voltage reference VREF = 2.5 V (ADC12VRSEL = 0x1, 0x7, 0x9, 0xB, or 0xD)		±0.2%	±1.8%	LSB
		With internal voltage reference VREF = 1.2 V (ADC12VRSEL = 0x1, 0x7, 0x9, 0xB, or 0xD)		±0.2%	±2.6%	
		With external voltage reference without internal buffer (ADC12VRSEL = 0x2 or 0x4) without TLV calibration, V _{R+} = 2.5 V, V _{R-} = AVSS		±1	±5	
		With external voltage reference with internal buffer (ADC12VRSEL = 0x3), V _{R+} = 2.5 V, V _{R-} = AVSS		±1	±28	

(1) Offset is measured as the input voltage (at which ADC output transitions from 0 to 1) minus 0.5 LSB.

(2) Offset increases as I_R drop increases when V_{R-} is AVSS.

(3) For details, see the *Device Descriptor Table* section in the [MSP430FR58xx](#), [MSP430FR59xx](#), [MSP430FR68xx](#), and [MSP430FR69xx Family User's Guide](#).

8.12.9.4 12-Bit ADC, Dynamic Performance With External Reference

over recommended ranges of supply voltage and operating free-air temperature (unless otherwise noted)

PARAMETER		TEST CONDITIONS	MIN	TYP	MAX	UNIT
Resolution	Number of no missing code output-code bits		12			bits
SNR	Signal-to-noise with differential inputs	V _{R+} = 2.5 V, V _{R-} = AVSS		71		dB
	Signal-to-noise with single-ended inputs	V _{R+} = 2.5 V, V _{R-} = AVSS		70		
ENOB	Effective number of bits with differential inputs ⁽¹⁾	V _{R+} = 2.5 V, V _{R-} = AVSS		11.4		bits
	Effective number of bits with single-ended inputs ⁽¹⁾	V _{R+} = 2.5 V, V _{R-} = AVSS		11.1		
	Effective number of bits with 32.768-kHz clock (reduced performance) ⁽¹⁾	Reduced performance with f _{ADC12CLK} from ACLK, LFXT 32.768 kHz, V _{R+} = 2.5 V, V _{R-} = AVSS		10.9		

(1) ENOB = (SINAD – 1.76) / 6.02

Section 8.12.9.5 lists the dynamic performance characteristics when using an internal reference.

8.12.9.5 12-Bit ADC, Dynamic Performance With Internal Reference

over recommended ranges of supply voltage and operating free-air temperature (unless otherwise noted)

PARAMETER		TEST CONDITIONS	MIN	TYP	MAX	UNIT
Resolution	Number of no missing code output code bits		12			bits
SNR	Signal-to-noise with differential inputs	$V_{R+} = 2.5\text{ V}, V_{R-} = AV_{SS}$		70		dB
	Signal-to-noise with single-ended inputs	$V_{R+} = 2.5\text{ V}, V_{R-} = AV_{SS}$		69		
ENOB	Effective number of bits with differential inputs ⁽¹⁾	$V_{R+} = 2.5\text{ V}, V_{R-} = AV_{SS}$		11.4		bits
	Effective number of bits with single-ended inputs ⁽¹⁾	$V_{R+} = 2.5\text{ V}, V_{R-} = AV_{SS}$		11.0		
	Effective number of bits with 32.768-kHz clock (reduced performance) ⁽¹⁾	Reduced performance with $f_{ADC12CLK}$ from ACLK LFXT 32.768 kHz, $V_{R+} = 2.5\text{ V}, V_{R-} = AV_{SS}$		10.9		

(1) $ENOB = (SINAD - 1.76) / 6.02$

Section 8.12.9.6 lists the temperature sensor and built-in V1/2 characteristics.

8.12.9.6 12-Bit ADC, Temperature Sensor and Built-In V_{1/2}

over recommended ranges of supply voltage and operating free-air temperature (unless otherwise noted)

PARAMETER		TEST CONDITIONS	MIN	TYP	MAX	UNIT
V _{SENSOR}	Temperature sensor voltage ^{(1) (2)} (see Figure 8-19)	ADC12ON = 1, ADC12TCMAP = 1, $T_A = 0^\circ\text{C}$		700		mV
TC _{SENSOR}	See ⁽²⁾	ADC12ON = 1, ADC12TCMAP = 1		2.5		mV/°C
t _{SENSOR(sample)}	Sample time required if ADCTCMAP = 1 and channel (MAX - 1) is selected ⁽³⁾	ADC12ON = 1, ADC12TCMAP = 1, Error of conversion result ≤ 1 LSB	30			μs
V _{1/2}	AVCC voltage divider for ADC12BATMAP = 1 on MAX input channel	ADC12ON = 1, ADC12BATMAP = 1	47.5%	50%	52.5%	
I _{V 1/2}	Current for battery monitor during sample time	ADC12ON = 1, ADC12BATMAP = 1		38	72	μA
t _{V 1/2 (sample)}	Sample time required if ADC12BATMAP = 1 and channel MAX is selected ⁽⁴⁾	ADC12ON = 1, ADC12BATMAP = 1	1.7			μs

- (1) The temperature sensor offset can be as much as $\pm 30^\circ\text{C}$. TI recommends a single-point calibration to minimize the offset error of the built-in temperature sensor.
- (2) The device descriptor structure contains calibration values for $30^\circ\text{C} \pm 3^\circ\text{C}$ and $85^\circ\text{C} \pm 3^\circ\text{C}$ for each of the available reference voltage levels. The sensor voltage can be computed as $V_{SENSE} = TC_{SENSOR} \times (\text{Temperature, } ^\circ\text{C}) + V_{SENSOR}$, where TC_{SENSOR} and V_{SENSOR} can be computed from the calibration values for higher accuracy.
- (3) The typical equivalent impedance of the sensor is 250 k Ω . The sample time required includes the sensor on time (t_{SENSOR(on)}).
- (4) The on time (t_{V1/2(on)}) is included in the sampling time (t_{V1/2(sample)}); no additional on time is needed.

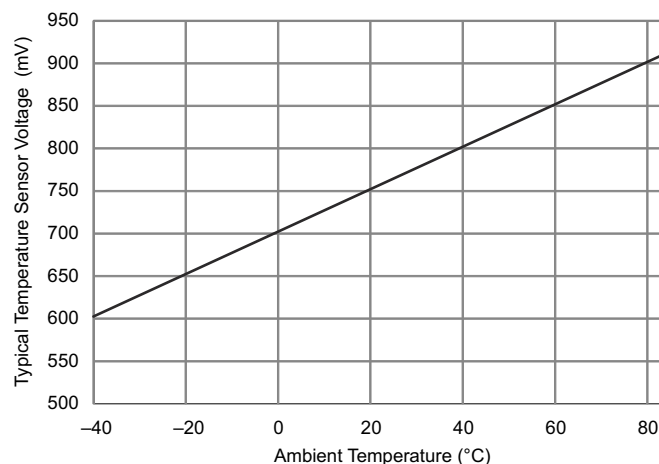

Figure 8-19. Typical Temperature Sensor Voltage

Section 8.12.9.7 lists the external reference characteristics.

8.12.9.7 12-Bit ADC, External Reference

over recommended ranges of supply voltage and operating free-air temperature (unless otherwise noted)⁽¹⁾

PARAMETER		TEST CONDITIONS	MIN	MAX	UNIT
V_{R+}	Positive external reference voltage input V_{eREF+} or V_{eREF-} based on ADC12VRSEL bit	$V_{R+} > V_{R-}$	1.2	V_{AVCC}	V
V_{R-}	Negative external reference voltage input V_{eREF+} or V_{eREF-} based on ADC12VRSEL bit	$V_{R+} > V_{R-}$	0	1.2	V
$V_{R+} - V_{R-}$	Differential external reference voltage input	$V_{R+} > V_{R-}$	1.2	V_{AVCC}	V
I_{VeREF+} , I_{VeREF-}	Static input current singled-ended input mode	$1.2\text{ V} \leq V_{eREF+} \leq V_{AVCC}$, $V_{eREF-} = 0\text{ V}$ $f_{ADC12CLK} = 5\text{ MHz}$, $ADC12SHTx = 1h$, $ADC12DIF = 0$, $ADC12PWRMD = 0$		± 10	μA
		$1.2\text{ V} \leq V_{eREF+} \leq V_{AVCC}$, $V_{eREF-} = 0\text{ V}$ $f_{ADC12CLK} = 5\text{ MHz}$, $ADC12SHTx = 8h$, $ADC12DIF = 0$, $ADC12PWRMD = 01$		± 2.5	
I_{VeREF+} , I_{VeREF-}	Static input current differential input mode	$1.2\text{ V} \leq V_{eREF+} \leq V_{AVCC}$, $V_{eREF-} = 0\text{ V}$ $f_{ADC12CLK} = 5\text{ MHz}$, $ADC12SHTx = 1h$, $ADC12DIF = 1$, $ADC12PWRMD = 0$		± 20	μA
		$1.2\text{ V} \leq V_{eREF+} \leq V_{AVCC}$, $V_{eREF-} = 0\text{ V}$ $f_{ADC12CLK} = 5\text{ MHz}$, $ADC12SHTx = 8h$, $ADC12DIF = 1$, $ADC12PWRMD = 1$		± 5	
I_{VeREF+}	Peak input current with single-ended input	$0\text{ V} \leq V_{eREF+} \leq V_{AVCC}$, $ADC12DIF = 0$		1.5	mA
I_{VeREF+}	Peak input current with differential input	$0\text{ V} \leq V_{eREF+} \leq V_{AVCC}$, $ADC12DIF = 1$		3	mA
$C_{VeREF+/-}$	Capacitance at V_{eREF+} or V_{eREF-} terminal	See ⁽²⁾	10		μF

- (1) The external reference is used during ADC conversion to charge and discharge the capacitance array. The input capacitance, C_i , is also the dynamic load for an external reference during conversion. The dynamic impedance of the reference supply should follow the recommendations on analog-source impedance to allow the charge to settle for 12-bit accuracy.
- (2) Two decoupling capacitors, 10 μF and 470 nF, should be connected to V_{eREF} to decouple the dynamic current required for an external reference source if it is used for the ADC12_B. Also see the [MSP430FR58xx](#), [MSP430FR59xx](#), [MSP430FR68xx](#), and [MSP430FR69xx Family User's Guide](#).

8.12.10 Reference

The reference module (REF) generates all of the critical reference voltages that can be used by various analog peripherals in a given device. The heart of the reference system is the bandgap from which all other references are derived by unity or noninverting gain stages. The REFGEN subsystem consists of the bandgap, the bandgap bias, and the noninverting buffer stage, which generates the three primary voltage reference available in the system (1.2 V, 2.0 V, and 2.5 V).

Section 8.12.10.1 lists the operating characteristics of the built-in reference.

8.12.10.1 REF, Built-In Reference

over recommended ranges of supply voltage and operating free-air temperature (unless otherwise noted)

PARAMETER	TEST CONDITIONS	V _{CC}	MIN	TYP	MAX	UNIT	
V _{REF+}	Positive built-in reference voltage output	REFVSEL = {2} for 2.5 V, REFON = 1	2.7 V	2.5	±1.5%	V	
		REFVSEL = {1} for 2.0 V, REFON = 1	2.2 V	2.0	±1.5%		
		REFVSEL = {0} for 1.2 V, REFON = 1	1.8 V	1.2	±1.8%		
Noise	RMS noise at VREF ⁽¹⁾	From 0.1 Hz to 10 Hz, REFVSEL = {0}		30	130	μV	
V _{OS_BUF_INT}	VREF ADC BUF_INT buffer offset ⁽³⁾	T _A = 25°C, ADC on, REFVSEL = {0}, REFON = 1, REFOUT = 0	-16		+16	mV	
V _{OS_BUF_EXT}	VREF ADC BUF_EXT buffer offset ⁽²⁾	T _A = 25°C, REFVSEL = {0}, REFOUT = 1, REFON = 1 or ADC on	-16		+16	mV	
AV _{CC(min)}	AVCC minimum voltage, Positive built-in reference active	REFVSEL = {0} for 1.2 V		1.8		V	
		REFVSEL = {1} for 2.0 V		2.2			
		REFVSEL = {2} for 2.5 V		2.7			
I _{REF+}	Operating supply current into AVCC terminal ⁽⁴⁾	REFON = 1	3 V	19	26	μA	
I _{REF+_ADC_BUF}	Operating supply current into AVCC terminal ⁽⁴⁾	ADC on, REFOUT = 0, REFVSEL = {0, 1, 2}, ADC12PWRMD = 0,	3 V		247	400	μA
		ADC on, REFOUT = 1, REFVSEL = {0, 1, 2}, ADC12PWRMD = 0			1053	1820	
		ADC on, REFOUT = 0, REFVSEL = {0, 1, 2}, ADC12PWRMD = 1			153	240	
		ADC on, REFOUT = 1, REFVSEL = {0, 1, 2}, ADC12PWRMD = 1			581	1030	
		ADC OFF, REFON = 1, REFOUT = 1, REFVSEL = {0, 1, 2}			1105	1890	
I _{O(VREF+)}	VREF maximum load current, VREF+ terminal	REFVSEL = {0, 1, 2}, AV _{CC} = AV _{CC(min)} for each reference level, REFON = REFOUT = 1		-1000		10	μA
ΔV _{out} /ΔI _{O(VREF+)}	Load-current regulation, VREF+ terminal	REFVSEL = {0, 1, 2}, I _{O(VREF+)} = +10 μA or -1000 μA AV _{CC} = AV _{CC(min)} for each reference level, REFON = REFOUT = 1				1500	μV/mA
C _{VREF+/-}	Capacitance at VREF+ and VREF- terminals	REFON = REFOUT = 1		0		100	pF
TC _{REF+}	Temperature coefficient of built-in reference	REFVSEL = {0, 1, 2}, REFON = REFOUT = 1, T _A = -40°C to 85°C ⁽⁵⁾		24		50	ppm/K
PSRR _{DC}	Power supply rejection ratio (DC)	AV _{CC} = AV _{CC(min)} to AV _{CC(max)} , T _A = 25°C, REFVSEL = {0, 1, 2}, REFON = REFOUT = 1		100		400	μV/V
PSRR _{AC}	Power supply rejection ratio (AC)	dAV _{CC} = 0.1 V at 1 kHz		3.0			mV/V
t _{SETTLE}	Settling time of reference voltage ⁽⁶⁾	AV _{CC} = AV _{CC(min)} to AV _{CC(max)} , REFVSEL = {0, 1, 2}, REFON = 0 → 1		40		80	μs

8.12.10.1 REF, Built-In Reference (continued)

over recommended ranges of supply voltage and operating free-air temperature (unless otherwise noted)

PARAMETER		TEST CONDITIONS	V _{CC}	MIN	TYP	MAX	UNIT
T _{buf_settle}	Settling time of ADC reference voltage buffer ⁽⁶⁾	AV _{CC} = AV _{CC(min)} to AV _{CC(max)} , REFVSEL = {0, 1, 2}, REFON = 1 (internal note should be for buf_int REFOUT=0 or buf_ext=1)			0.4	2	μs

- (1) Internal reference noise affects ADC performance when ADC uses internal reference. See [Designing With the MSP430FR58xx, FR59xx, FR68xx, and FR69xx ADC](#) for details on optimizing ADC performance for your application with the choice of internal or external reference.
- (2) Buffer offset affects ADC gain error and thus total unadjusted error.
- (3) Buffer offset affects ADC gain error and thus total unadjusted error.
- (4) The internal reference current is supplied through the AV_{CC} terminal.
- (5) Calculated using the box method: (MAX(−40°C to 85°C) – MIN(−40°C to 85°C)) / MIN(−40°C to 85°C)/(85°C – (−40°C)).
- (6) The condition is that the error in a conversion started after t_{REFON} is less than ±0.5 LSB.

8.12.11 Comparator

The COMP_E module supports precision slope analog-to-digital conversions, supply voltage supervision, and monitoring of external analog signals. [Section 8.12.11.1](#) lists the comparator characteristics.

8.12.11.1 Comparator_E

over recommended ranges of supply voltage and operating free-air temperature (unless otherwise noted)

PARAMETER		TEST CONDITIONS	V _{CC}	MIN	TYP	MAX	UNIT	
I _{AVCC_COMP}	Comparator operating supply current into AV _{CC} , excludes reference resistor ladder	CEPW _{RMD} = 00, CEON = 1, CERS _x = 00 (fast)	2.2 V, 3.0 V		12	16	μA	
		CEPW _{RMD} = 01, CEON = 1, CERS _x = 00 (medium)			10	14		
		CEPW _{RMD} = 10, CEON = 1, CERS _x = 00 (slow), T _A = 30°C			0.1	0.3		
		CEPW _{RMD} = 10, CEON = 1, CERS _x = 00 (slow), T _A = 85°C			0.3	1.3		
I _{AVCC_COMP_REF}	Quiescent current of Comparator and resistor ladder into AV _{CC} , including REF module current	CEPW _{RMD} = 10, CEREF _{Lx} = 01, CERS _x = 10, CEON = 1, REFON = 0	2.2 V, 3.0 V	CEREF _{ACC} = 0		31	38	μA
		CEREF _{ACC} = 1			16	19		
V _{REF}	Reference voltage level	CERS _x = 11, CEREF _{Lx} = 01, CEREF _{ACC} = 0	1.8 V	1.152	1.2	1.248	V	
		CERS _x = 11, CEREF _{Lx} = 10, CEREF _{ACC} = 0	2.2 V	1.92	2.0	2.08		
		CERS _x = 11, CEREF _{Lx} = 11, CEREF _{ACC} = 0	2.7 V	2.40	2.5	2.60		
		CERS _x = 11, CEREF _{Lx} = 01, CEREF _{ACC} = 1	1.8 V	1.10	1.2	1.245		
		CERS _x = 11, CEREF _{Lx} = 10, CEREF _{ACC} = 1	2.2 V	1.90	2.0	2.08		
		CERS _x = 11, CEREF _{Lx} = 11, CEREF _{ACC} = 1	2.7 V	2.35	2.5	2.60		
V _{IC}	Common mode input range			0		V _{CC} – 1	V	
V _{OFFSET}	Input offset voltage	CEPW _{RMD} = 00		−16		16	mV	
		CEPW _{RMD} = 01		−12		12		
		CEPW _{RMD} = 10		−37		37		
C _{IN}	Input capacitance	CEPW _{RMD} = 00 or CEPW _{RMD} = 01			10		pF	
		CEPW _{RMD} = 10			10			

8.12.11.1 Comparator_E (continued)

over recommended ranges of supply voltage and operating free-air temperature (unless otherwise noted)

PARAMETER		TEST CONDITIONS		V _{CC}	MIN	TYP	MAX	UNIT
R _{SIN}	Series input resistance	On (switch closed)			1		3	kΩ
		Off (switch open)			50			MΩ
t _{PD}	Propagation delay, response time	CEF = 0, Overdrive ≥ 20 mV	CEPWRMD = 00		193		330	ns
			CEPWRMD = 01		230		400	
			CEPWRMD = 10		5		15	μs
t _{PD,filter}	Propagation delay with filter active	CEPWRMD = 00 or 01, CEF = 1, Overdrive ≥ 20 mV	CEFDLY = 00		700		1000	ns
			CEFDLY = 01		1.0		1.9	
			CEFDLY = 10		2.0		3.7	μs
			CEFDLY = 11		4.0		7.7	
t _{EN_CMP}	Comparator enable time	CEON = 0 → 1, V _{IN+} and V _{IN-} from pins, Overdrive ≥ 20 mV	CEPWRMD = 00		0.9		1.5	μs
			CEPWRMD = 01		0.9		1.5	
			CEPWRMD = 10		15		65	
t _{EN_CMP_VREF}	Comparator and reference ladder and reference voltage enable time	CEON = 0 → 1, CEREF _{FLX} = 10, CERS _x = 10 or 11, CEREF ₀ = CEREF ₁ = 0x0F, REFON = 0			120		220	μs
t _{EN_CMP_RL}	Comparator and reference ladder enable time	CEON = 0 → 1, CEREF _{FLX} = 10, CERS _x = 10, REFON = 1, CEREF ₀ = CEREF ₁ = 0x0F			10		30	μs
V _{CE_REF}	Reference voltage for a given tap	V _{IN} = reference into resistor ladder (n = 0 to 31)			$\frac{V_{IN} \times (n + 0.5)}{32}$	$\frac{V_{IN} \times (n + 1)}{32}$	$\frac{V_{IN} \times (n + 1.5)}{32}$	V

8.12.12 FRAM

FRAM is a nonvolatile memory that reads and writes like standard SRAM. The FRAM can be read in a similar fashion to SRAM and needs no special requirements. Similarly, any writes to unprotected segments can be written in the same fashion as SRAM.

Section 8.12.12.1 lists the operating characteristics of the FRAM.

8.12.12.1 FRAM

over recommended ranges of supply voltage and operating free-air temperature (unless otherwise noted)

PARAMETER		TEST CONDITIONS	MIN	TYP	MAX	UNIT
Read and write endurance			10 ¹⁵			cycles
t _{Retention}	Data retention duration	T _J = 25°C	100			years
		T _J = 70°C	40			
		T _J = 85°C	10			
I _{WRITE}	Current to write into FRAM		I _{READ} ⁽¹⁾		nA	
I _{ERASE}	Erase current		n/a ⁽²⁾		nA	
t _{WRITE}	Write time		t _{READ} ⁽³⁾		ns	
t _{READ}	Read time	NWAITS _x = 0	1 / f _{SYSTEM} ⁽⁴⁾		ns	
		NWAITS _x = 1	2 / f _{SYSTEM} ⁽⁴⁾			

(1) Writing to FRAM does not require a setup sequence or additional power when compared to reading from FRAM. The FRAM read current (I_{READ}) is included in the active mode current consumption, I_{AM,FRAM}.

(2) FRAM does not require a special erase sequence.

(3) Writing into FRAM is as fast as reading.

(4) The maximum read (and write) speed is specified by f_{SYSTEM} using the appropriate wait state settings (NWAITS_x).

8.12.13 Emulation and Debug

The MSP family supports the standard JTAG interface, which requires four signals for sending and receiving data. The JTAG signals are shared with general-purpose I/Os. The TEST/SBWTCK pin is used to enable the connection of external development tools with the device through Spy-Bi-Wire or JTAG debug protocols. The connection is usually enabled when the TEST/SBWTCK is high. When the connection is enabled, the device enters a debug mode. In the debug mode, the times for entry to and wake up from low-power modes may be different compared to normal operation. Pay careful attention to the real-time behavior when using low-power modes with the device connected to a development tool.

Section 8.12.13.1 lists the JTAG and Spy-Bi-Wire interface characteristics.

8.12.13.1 JTAG and Spy-Bi-Wire Interface

over recommended ranges of supply voltage and operating free-air temperature (unless otherwise noted)

PARAMETER		V _{CC}	MIN	TYP	MAX	UNIT
I _{JTAG}	Supply current adder when JTAG active (but not clocked)	2.2 V, 3.0 V		40	100	μA
f _{SBW}	Spy-Bi-Wire input frequency	2.2 V, 3.0 V	0		10	MHz
t _{SBW,Low}	Spy-Bi-Wire low clock pulse duration	2.2 V, 3.0 V	0.04		15	μs
t _{SBW,En}	Spy-Bi-Wire enable time (TEST high to acceptance of first clock edge) ⁽¹⁾	2.2 V, 3.0 V			110	μs
t _{SBW,Rst}	Spy-Bi-Wire return to normal operation time		15		100	μs
f _{TCK}	TCK input frequency, 4-wire JTAG ⁽²⁾	2.2 V	0		16	MHz
		3.0 V	0		16	
R _{internal}	Internal pulldown resistance on TEST	2.2 V, 3.0 V	20	35	50	kΩ
f _{TCLK}	TCLK and MCLK frequency during JTAG access, no FRAM access (limited by f _{SYSTEM})				16	MHz
t _{TCLK,Low/High}	TCLK low or high clock pulse duration, no FRAM access				25	ns
f _{TCLK,FRAM}	TCLK and MCLK frequency during JTAG access, including FRAM access (limited by f _{SYSTEM} with no FRAM wait states)				4	MHz
t _{TCLK,FRAM,Low/High}	TCLK low or high clock pulse duration, including FRAM accesses				100	ns

- (1) Tools that access the Spy-Bi-Wire and the BSL interfaces must wait for the t_{SBW,En} time after the first transition of the TEST/SBWTCK pin (low to high), before the second transition of the pin (high to low) during the entry sequence.
- (2) f_{TCK} may be restricted to meet the timing requirements of the module selected.

9 Detailed Description

9.1 Overview

The TI MSP430FR59xx family of ultra-low-power microcontrollers consists of several devices featuring different sets of peripherals. The architecture, combined with seven low-power modes, is optimized to achieve extended battery life for example in portable measurement applications. The device features a powerful 16-bit RISC CPU, 16-bit registers, and constant generators that contribute to maximum code efficiency.

The device is an MSP430FR59xx family device with Low-Energy Accelerator (LEA) (available only on the MSP430FR599x MCUs), up to six 16-bit timers, up to eight eUSCs that support UART, SPI, and I²C, a comparator, a hardware multiplier, an AES accelerator, a 6-channel DMA, an RTC module with alarm capabilities, up to 67 I/O pins, and a high-performance 12-bit ADC.

9.2 CPU

The MSP430 CPU has a 16-bit RISC architecture that is highly transparent to the application. All operations, other than program-flow instructions, are performed as register operations in conjunction with seven addressing modes for source operand and four addressing modes for destination operand.

The CPU is integrated with 16 registers that provide reduced instruction execution time. The register-to-register operation execution time is one cycle of the CPU clock.

Four of the registers, R0 to R3, are dedicated as program counter, stack pointer, status register, and constant generator, respectively. The remaining registers are general-purpose registers.

Peripherals are connected to the CPU using data, address, and control buses. The peripherals can be managed with all instructions.

The instruction set consists of the original 51 instructions with three formats and seven address modes and additional instructions for the expanded address range. Each instruction can operate on word and byte data.

9.3 Low-Energy Accelerator (LEA) for Signal Processing (MSP430FR599x Only)

The LEA module is a hardware engine designed for operations that involve vector-based signal processing, such as FIR, IIR, and FFT. The subsystem offers fast performance and low energy consumption when performing vector-based digital signal processing computations; for performance benchmarks comparing the LEA module to using the CPU or other processors, see [Benchmarking the Signal Processing Capabilities of the Low-Energy Accelerator on MSP MCUs](#).

The LEA module requires MCLK to be operational; therefore, the subsystem can run only in active mode or LPM0 (see [Table 9-1](#)). While the LEA module is running, the LEA data operations are performed on a shared 4KB of RAM out of the 8KB of total RAM (see [Table 9-41](#)). This shared RAM can also be used by the regular application. The MSP CPU and the LEA module can run simultaneously and independently unless they access the same system RAM.

Direct access to LEA registers is not supported, and TI recommends using the optimized [Digital Signal Processing \(DSP\) Library for MSP Microcontrollers](#) for the operations that the LEA module supports.

9.4 Operating Modes

The MCU has one active mode and seven software selectable low-power modes of operation. An interrupt event can wake up the device from low-power modes LPM0 through LPM4, service the request, and restore back to the low-power mode on return from the interrupt program. Low-power modes LPM3.5 and LPM4.5 disable the core supply to minimize power consumption.

Note

XT1CLK and VLOCLK can be active during LPM4 if requested by low-frequency peripherals such as RTC or WDT.

Table 9-1. Operating Modes

MODE	AM		LPM0	LPM1	LPM2	LPM3	LPM4	LPM3.5	LPM4.5	
	ACTIVE	ACTIVE, FRAM OFF ⁽¹⁾	CPU OFF ⁽²⁾	CPU OFF	STANDBY	STANDBY	OFF	RTC ONLY	SHUTDOWN WITH SVS	SHUTDOWN WITHOUT SVS
Maximum system clock	16 MHz		16 MHz	16 MHz	50 kHz	50 kHz	0 ⁽³⁾	50 kHz	0 ⁽³⁾	
Typical current consumption, T _A = 25°C	120 µA/MHz	65 µA/MHz	92 µA at 1 MHz	40 µA at 1 MHz	1.0 µA	0.7 µA	0.5 µA	0.45 µA	0.3 µA	0.07 µA
Typical wake-up time	N/A		Instant	6 µs	6 µs	7 µs	7 µs	250 µs	250 µs	400 µs
Wake-up events	N/A		All	All	LF RTC I/O Comp	LF RTC I/O Comp	I/O Comp	RTC I/O	I/O	
CPU	On		Off	Off	Off	Off	Off	Reset	Reset	
LEA (MSP430FR599x only)	On		On ⁽⁴⁾ Off	Off	Off	Off	Off	Reset	Reset	
FRAM	On	Off ⁽¹⁾	Standby (or off ⁽¹⁾)	Off	Off	Off	Off	Off	Off	
High-frequency peripherals ⁽⁵⁾	Available		Available	Available	Off	Off	Off	Reset	Reset	
Low-frequency peripherals ⁽⁵⁾	Available		Available	Available	Available	Available ⁽⁶⁾	Off	RTC	Reset	
Unlocked peripherals ⁽⁵⁾	Available		Available	Available	Available	Available ⁽⁶⁾	Available ⁽⁶⁾	Reset	Reset	
MCLK	On		On ⁽⁴⁾ Off	Off	Off	Off	Off	Off	Off	
SMCLK	Optional ⁽⁷⁾		Optional ⁽⁷⁾	Optional ⁽⁷⁾	Off	Off	Off	Off	Off	
ACLK	On		On	On	On	On	Off	Off	Off	
Full retention	Yes		Yes	Yes	Yes	Yes	Yes	No	No	
SVS	Always		Always	Always	Optional ⁽⁸⁾	Optional ⁽⁸⁾	optional ⁽⁸⁾	Optional ⁽⁸⁾	On ⁽⁹⁾	Off ⁽¹⁰⁾
Brownout	Always		Always	Always	Always	Always	Always	Always	Always	

- (1) FRAM disabled in FRAM controller A
- (2) Disabling the FRAM through the FRAM controller A allows the application to lower the LPM current consumption but the wake-up time increases when FRAM is accessed (for example, to fetch an interrupt vector). For a wake up that does not access FRAM (for example, a DMA transfer to RAM) the wake-up time is not increased.
- (3) All clocks disabled
- (4) Only while the LEA module is performing the task enabled by CPU during AM. The LEA module cannot be enabled in LPM0.
- (5) See [Section 9.4.1](#) for a detailed description of high-frequency, low-frequency, and unlocked peripherals.
- (6) See [Section 9.4.2](#), which describes the use of peripherals in LPM3 and LPM4.

- (7) Controlled by SMCLKOFF
- (8) Activate SVS (SVSHE = 1) results in higher current consumption. SVS is not included in typical current consumption.
- (9) SVSHE = 1
- (10) SVSHE = 0

9.4.1 Peripherals in Low-Power Modes

Peripherals can be in different states that impact the achievable power modes of the device. The states depend on the operational modes of the peripherals (see [Table 9-2](#)). The states are:

- A peripheral is in a *high-frequency state* if it requires or uses a clock with a "high" frequency of more than 50 kHz.
- A peripheral is in a *low-frequency state* if it requires or uses a clock with a "low" frequency of 50 kHz or less.
- A peripheral is in an *unlocked state* if it does not require or use an internal clock.

If the CPU requests a power mode that does not support the current state of all active peripherals, the device does not enter the requested power mode, but it does enter a power mode that still supports the current state of the peripherals, except if an external clock is used. If an external clock is used, the application must use the correct frequency range for the requested power mode.

Table 9-2. Peripheral States

PERIPHERAL	IN HIGH-FREQUENCY STATE ⁽¹⁾	IN LOW-FREQUENCY STATE ⁽²⁾	IN UNLOCKED STATE ⁽³⁾
WDT	Clocked by SMCLK	Clocked by ACLK	Not applicable
DMA ⁽⁴⁾	Not applicable	Not applicable	Waiting for a trigger
RTC_C	Not applicable	Clocked by LFXT	Not applicable
Timer_A TAx	Clocked by SMCLK or clocked by external clock >50 kHz	Clocked by ACLK or clocked by external clock ≤50 kHz	Clocked by external clock ≤50 kHz
Timer_B TBx	Clocked by SMCLK or clocked by external clock >50 kHz	Clocked by ACLK or clocked by external clock ≤50 kHz	Clocked by external clock ≤50 kHz
eUSCI_Ax in UART mode	Clocked by SMCLK	Clocked by ACLK	Waiting for first edge of START bit.
eUSCI_Ax in SPI master mode	Clocked by SMCLK	Clocked by ACLK	Not applicable
eUSCI_Ax in SPI slave mode	Clocked by external clock >50 kHz	Clocked by external clock ≤50 kHz	Clocked by external clock ≤50 kHz
eUSCI_Bx in I ² C master mode	Clocked by SMCLK or clocked by external clock >50 kHz	Clocked by ACLK or clocked by external clock ≤50 kHz	Not applicable
eUSCI_Bx in I ² C slave mode	Clocked by external clock >50 kHz	Clocked by external clock ≤50 kHz	Waiting for START condition or clocked by external clock ≤50 kHz
eUSCI_Bx in SPI master mode	Clocked by SMCLK	Clocked by ACLK	Not applicable
eUSCI_Bx in SPI slave mode	Clocked by external clock >50 kHz	Clocked by external clock ≤50 kHz	Clocked by external clock ≤50 kHz
ADC12_B	Clocked by SMCLK or by MODOSC	Clocked by ACLK	Waiting for a trigger
REF_A	Not applicable	Not applicable	Always
COMP_E	Not applicable	Not applicable	Always
CRC ⁽⁵⁾	Not applicable	Not applicable	Not applicable
MPY ⁽⁵⁾	Not applicable	Not applicable	Not applicable
AES ⁽⁵⁾	Not applicable	Not applicable	Not applicable

- (1) Peripherals are in a state that requires or uses a clock with a "high" frequency of more than 50 kHz
- (2) Peripherals are in a state that requires or uses a clock with a "low" frequency of 50 kHz or less.
- (3) Peripherals are in a state that does not require or does not use an internal clock.
- (4) The DMA always transfers data in active mode but can wait for a trigger in any low-power mode. A DMA trigger during a low-power mode causes a temporary transition into active mode for the time of the transfer.
- (5) This peripheral operates during active mode only and will delay the transition into a low-power mode until its operation is completed.

9.4.2 Idle Currents of Peripherals in LPM3 and LPM4

Most peripherals can be operational in LPM3 if clocked by ACLK. Some modules are operational in LPM4, because they do not require a clock to operate (for example, the comparator). Activating a peripheral in LPM3 or LPM4 increases the current consumption due to its active supply current contribution but also due to an additional idle current. To reduce the idle current adder, certain peripherals are grouped together (see [Table 9-3](#)). To achieve optimal current consumption, use modules within one group and limit the number of groups with active modules. Modules not listed in [Table 9-3](#) are either already included in the standard LPM3 current consumption or cannot be used in LPM3 or LPM4.

The idle current adder is very small at room temperature (25°C) but increases at high temperatures (85°C). See the I_{IDLE} current parameters in [Section 8](#) for details.

Table 9-3. Peripheral Groups

GROUP A	GROUP B	GROUP C
Timer TA1	Timer TA0	Timer TA4
Timer TA2	Timer TA3	eUSCI_A2
Timer TB0	Comparator	eUSCI_A3
eUSCI_A0	ADC12_B	eUSCI_B1
eUSCI_A1	REF_A	eUSCI_B2
eUSCI_B0		eUSCI_B3

9.5 Interrupt Vector Table and Signatures

The interrupt vectors, the power-up start address and signatures are in the address range 0FFFFh to 0FF80h. [Figure 9-1](#) summarizes the content of this address range.

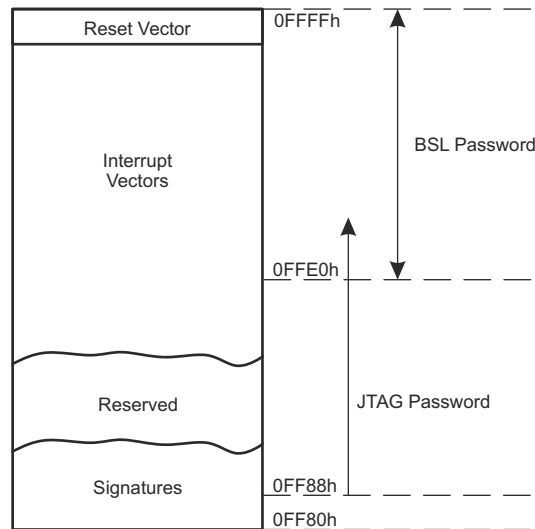

Figure 9-1. Interrupt Vectors, Signatures and Passwords

The power-up start address or reset vector is at 0FFFFh to 0FFFEh. This location contains a 16-bit address pointing to the start address of the application program.

The interrupt vectors start at 0FFFDh and extend to lower addresses. Each vector contains the 16-bit address of the appropriate interrupt-handler instruction sequence. [Table 9-4](#) shows the device specific interrupt vector locations.

The vectors programmed into the address range from 0FFFFh to 0FFE0h are used as BSL password (if enabled by the corresponding signature).

The signatures are at 0FF80h and extend to higher addresses. Signatures are evaluated during device start-up. [Table 9-5](#) lists the device-specific signature locations.

A JTAG password can be programmed starting at address 0FF88h and extending to higher addresses. The password can extend into the interrupt vector locations using the interrupt vector addresses as additional bits for the password. The length of the JTAG password depends on the JTAG signature.

See the *System Resets, Interrupts, and Operating Modes, System Control Module (SYS)* chapter in the *MSP430FR58xx, MSP430FR59xx, and MSP430FR6xx Family User's Guide* for details.

Table 9-4. Interrupt Sources, Flags, and Vectors

INTERRUPT SOURCE	INTERRUPT FLAG	INTERRUPT VECTOR REGISTER	SYSTEM INTERRUPT	WORD ADDRESS	PRIORITY
System Reset Power up, brownout, supply supervisor External reset, \overline{RST} Watchdog time-out (watchdog mode) WDT, FRCTL MPU, CS, PMM password violation FRAM uncorrectable bit error detection MPU segment violation Software POR, BOR	SVSHIFG PMMRSTIFG WDTIFG WDTPW, FRCTLPW, MPUPW, CSPW, PMMPW UBDIFG MPUSEGIIFG, MPUSEG1IFG, MPUSEG2IFG, MPUSEG3IFG PMMPORIFG, PMMBORIFG	SYSRSTIV ⁽¹⁾	Reset	0FFFEh	Highest
System NMI Vacant memory access ⁽²⁾ JTAG mailbox FRAM access time error FRAM write protection error FRAM bit error detection MPU segment violation	VMAIFG JMBINIFG, JMBOUTIFG ACCTEIFG WPIFG CBDIFG, UBDIFG MPUSEGIIFG, MPUSEG1IFG, MPUSEG2IFG, MPUSEG3IFG	SYSSNIV ⁽¹⁾	(Non)maskable ⁽³⁾	0FFFCh	
User NMI External NMI Oscillator fault	NMIIFG OFIFG	SYSUNIV ⁽¹⁾	(Non)maskable ⁽³⁾	0FFFAh	
Comparator_E	CEIFG, CEIIFG	CEIV ⁽¹⁾	Maskable	0FFF8h	
TB0	TB0CCR0 CCIFG		Maskable	0FFF6h	
TB0	TB0CCR1 CCIFG to TB0CCR6 CCIFG, TB0CTL.TBIFG	TB0IV ⁽¹⁾	Maskable	0FFF4h	
Watchdog timer (interval timer mode)	WDTIFG		Maskable	0FFF2h	
eUSCI_A0 receive or transmit	UCRXIFG, UCTXIFG (SPI mode) UCSTTIFG, UCTXCPITIFG, UCRXIFG, UCTXIFG (UART mode)	UCA0IV ⁽¹⁾	Maskable	0FFF0h	
eUSCI_B0 receive or transmit	UCRXIFG, UCTXIFG (SPI mode) UCALIFG, UCNACKIFG, UCSTTIFG, UCSTPIFG, UCRXIFG0, UCTXIFG0, UCRXIFG1, UCTXIFG1, UCRXIFG2, UCTXIFG2, UCRXIFG3, UCTXIFG3, UCCNTIFG, UCBIT9IFG (I ² C mode)	UCB0IV ⁽¹⁾	Maskable	0FFEEh	
ADC12_B ⁽⁴⁾	ADC12IFG0 to ADC12IFG31, ADC12LOIFG, ADC12INIFG, ADC12HIIFG, ADC12RDYIFG, ADC21OVIFG, ADC12TOVIFG	ADC12IV ⁽¹⁾	Maskable	0FFECh	

Table 9-4. Interrupt Sources, Flags, and Vectors (continued)

INTERRUPT SOURCE	INTERRUPT FLAG	INTERRUPT VECTOR REGISTER	SYSTEM INTERRUPT	WORD ADDRESS	PRIORITY
TA0	TA0CCR0 CCIFG		Maskable	0FFEAh	
TA0	TA0CCR1 CCIFG, TA0CCR2 CCIFG, TA0CTL.TAIFG	TA0IV ⁽¹⁾	Maskable	0FFE8h	
eUSCI_A1 receive or transmit	UCRXIFG, UCTXIFG (SPI mode) UCSTTIFG, UCTXCPITFG, UCRXIFG, UCTXIFG (UART mode)	UCA1IV ⁽¹⁾	Maskable	0FFE6h	
DMA	DMA0CTL.DMAIFG, DMA1CTL.DMAIFG, DMA2CTL.DMAIFG	DMAIV ⁽¹⁾	Maskable	0FFE4h	
TA1	TA1CCR0 CCIFG		Maskable	0FFE2h	
TA1	TA1CCR1 CCIFG, TA1CCR2 CCIFG, TA1CTL.TAIFG	TA1IV ⁽¹⁾	Maskable	0FFE0h	
I/O port P1	P1IFG.0 to P1IFG.7	P1IV ⁽¹⁾	Maskable	0FFDEh	
TA2	TA2CCR0 CCIFG		Maskable	0FFDCh	
TA2	TA2CCR1 CCIFG, TA2CTL.TAIFG	TA2IV ⁽¹⁾	Maskable	0FFDAh	
I/O port P2	P2IFG.0 to P2IFG.7	P2IV ⁽¹⁾	Maskable	0FFD8h	
TA3	TA3CCR0 CCIFG		Maskable	0FFD6h	
TA3	TA3CCR1 CCIFG, TA3CTL.TAIFG	TA3IV ⁽¹⁾	Maskable	0FFD4h	
I/O port P3	P3IFG.0 to P3IFG.7	P3IV ⁽¹⁾	Maskable	0FFD2h	
I/O port P4	P4IFG.0 to P4IFG.7	P4IV ⁽¹⁾	Maskable	0FFD0h	
RTC_C	RTCRDYIFG, RTCTEVIFG, RTCAIFG, RT0PSIFG, RT1PSIFG, RTCOFIFG	RTCIV ⁽¹⁾	Maskable	0FFCEh	
AES	AESRDYIFG		Maskable	0FFCCh	
TA4	TA4CCR0 CCIFG		Maskable	0FFCAh	
TA4	TA4CCR1 CCIFG, TA4CTL.TAIFG	TA4IV ⁽¹⁾	Maskable	0FFC8h	
I/O port P5	P5IFG.0 to P5IFG.7	P5IV ⁽¹⁾	Maskable	0FFC6h	
I/O port P6	P6IFG.0 to P6IFG.7	P6IV ⁽¹⁾	Maskable	0FFC4h	
eUSCI_A2 receive or transmit	UCRXIFG, UCTXIFG (SPI mode)	UCA2IV ⁽¹⁾	Maskable	0FFC2h	
	UCSTTIFG, UCTXCPITFG, UCRXIFG, UCTXIFG (UART mode)				
eUSCI_A3 receive or transmit	UCRXIFG, UCTXIFG (SPI mode)	UCA3IV ⁽¹⁾	Maskable	0FFC0h	
	UCSTTIFG, UCTXCPITFG, UCRXIFG, UCTXIFG (UART mode)				
eUSCI_B1 receive or transmit	UCRXIFG, UCTXIFG (SPI mode)	UCB1IV ⁽¹⁾	Maskable	0FFBEh	
	UCALIFG, UCNACKIFG, UCSTTIFG, UCSTPIFG, UCRXIFG0, UCTXIFG0, UCRXIFG1, UCTXIFG1, UCRXIFG2, UCTXIFG2, UCRXIFG3, UCTXIFG3, UCCNTIFG, UCBIT9IFG (I ² C mode)				
eUSCI_B2 receive or transmit	UCRXIFG, UCTXIFG (SPI mode)	UCB2IV ⁽¹⁾	Maskable	0FFBCh	
	UCALIFG, UCNACKIFG, UCSTTIFG, UCSTPIFG, UCRXIFG0, UCTXIFG0, UCRXIFG1, UCTXIFG1, UCRXIFG2, UCTXIFG2, UCRXIFG3, UCTXIFG3, UCCNTIFG, UCBIT9IFG (I ² C mode)				
eUSCI_B3 receive or transmit	UCRXIFG, UCTXIFG (SPI mode)	UCB3IV ⁽¹⁾	Maskable	0FFBAh	
	UCALIFG, UCNACKIFG, UCSTTIFG, UCSTPIFG, UCRXIFG0, UCTXIFG0, UCRXIFG1, UCTXIFG1, UCRXIFG2, UCTXIFG2, UCRXIFG3, UCTXIFG3, UCCNTIFG, UCBIT9IFG (I ² C mode)				

Table 9-4. Interrupt Sources, Flags, and Vectors (continued)

INTERRUPT SOURCE	INTERRUPT FLAG	INTERRUPT VECTOR REGISTER	SYSTEM INTERRUPT	WORD ADDRESS	PRIORITY
I/O port P7	P7IFG.0 to P7IFG.7	P7IV ⁽¹⁾	Maskable	0FFB8h	
I/O port P8	P8IFG.0 to P8IFG.7	P8IV ⁽¹⁾	Maskable	0FFB6h	
LEA (MSP430FR599x only)	CMDIFG, SDIIFG, OORIFG, TIFG, COVLIFG	LEAIV ⁽¹⁾	Maskable	0FFB4h	Lowest

- (1) Multiple source flags
- (2) A reset is generated if the CPU tries to fetch instructions from peripheral space.
- (3) (Non)maskable: the individual interrupt enable bit can disable an interrupt event, but the general interrupt enable bit cannot disable it.
- (4) Only on devices with ADC, otherwise reserved.

Table 9-5. Signatures

SIGNATURE	WORD ADDRESS
IP Encapsulation Signature 2	0FF8Ah
IP Encapsulation Signature 1 ⁽¹⁾	0FF88h
BSL Signature 2	0FF86h
BSL Signature 1	0FF84h
JTAG Signature 2	0FF82h
JTAG Signature 1	0FF80h

- (1) Must not contain 0AAAAh if used as the JTAG password.

9.6 Bootloader (BSL)

The BSL can program the FRAM or RAM using a UART serial interface (FRxxxx devices) or an I²C interface (FRxxxx1 devices). Access to the device memory through the BSL is protected by a user-defined password. [Table 9-6](#) lists the pins that are required to use the BSL. BSL entry requires a specific entry sequence on the RST/NMI/SBWTIO and TEST/SBWTCK pins. For a complete description of the features of the BSL and its implementation, see the [MSP430 FRAM Devices Bootloader \(BSL\) User's Guide](#). Visit [Bootloader \(BSL\) for MSP low-power microcontrollers](#) for more information.

Table 9-6. BSL Pin Requirements and Functions

DEVICE SIGNAL	BSL FUNCTION
RST/NMI/SBWTIO	Entry sequence signal
TEST/SBWTCK	Entry sequence signal
P2.0	Devices with UART BSL (FRxxxx): Data transmit
P2.1	Devices with UART BSL (FRxxxx): Data receive
P1.6	Devices with I ² C BSL (FRxxxx1): Data
P1.7	Devices with I ² C BSL (FRxxxx1): Clock
DVCC	Power supply
DVSS	Ground supply

9.7 JTAG Operation

9.7.1 JTAG Standard Interface

The MSP family supports the standard JTAG interface, which requires four signals for sending and receiving data. The JTAG signals are shared with general-purpose I/O. The TEST/SBWTCK pin is used to enable the JTAG signals. In addition to these signals, the $\overline{\text{RST}}$ /NMI/SBWDIO is required to interface with MSP development tools and device programmers. [Table 9-7](#) lists the JTAG pin requirements. For further details on interfacing to development tools and device programmers, see the [MSP430 Hardware Tools User's Guide](#). For a complete description of the features of the JTAG interface and its implementation, see [MSP430 Programming With the JTAG Interface](#).

Table 9-7. JTAG Pin Requirements and Functions

DEVICE SIGNAL	DIRECTION	FUNCTION
PJ.3/TCK	IN	JTAG clock input
PJ.2/TMS	IN	JTAG state control
PJ.1/TDI/TCLK	IN	JTAG data input, TCLK input
PJ.0/TDO	OUT	JTAG data output
TEST/SBWTCK	IN	Enable JTAG pins
$\overline{\text{RST}}$ /NMI/SBWDIO	IN	External reset
DVCC		Power supply
DVSS		Ground supply

9.7.2 Spy-Bi-Wire Interface

In addition to the standard JTAG interface, the MSP family supports the two wire Spy-Bi-Wire interface. Spy-Bi-Wire can be used to interface with MSP development tools and device programmers. The Spy-Bi-Wire interface pin requirements are shown in [Table 9-8](#). For further details on interfacing to development tools and device programmers, see the [MSP430 Hardware Tools User's Guide](#). For a complete description of the features of the JTAG interface and its implementation, see [MSP430 Programming With the JTAG Interface](#).

Table 9-8. Spy-Bi-Wire Pin Requirements and Functions

DEVICE SIGNAL	DIRECTION	FUNCTION
TEST/SBWTCK	IN	Spy-Bi-Wire clock input
$\overline{\text{RST}}$ /NMI/SBWDIO	IN, OUT	Spy-Bi-Wire data input and output
DVCC		Power supply
DVSS		Ground supply

9.8 FRAM Controller A (FRCTL_A)

The FRAM can be programmed through the JTAG port, Spy-Bi-Wire (SBW), the BSL, or in system by the CPU (also see [Table 9-45](#) for control and configuration registers). Features of the FRAM include:

- Ultra-low-power ultra-fast-write nonvolatile memory
- Byte and word access capability
- Programmable wait state generation
- Error correction coding (ECC)

Note

Wait States

For MCLK frequencies > 8 MHz, wait states must be configured following the flow described in the "Wait State Control" section of the *FRAM Controller A (FRCTL_A)* chapter in the [MSP430FR58xx, MSP430FR59xx, and MSP430FR6xx Family User's Guide](#).

For important software design information regarding FRAM including but not limited to partitioning the memory layout according to application-specific code, constant, and data space requirements, the use of FRAM to optimize application energy consumption, and the use of the Memory Protection Unit (MPU) to maximize application robustness by protecting the program code against unintended write accesses, see [MSP430™ FRAM Technology – How To and Best Practices](#).

9.9 RAM

The RAM is made up of three sectors: Sector 0 = 2KB, Sector 1 = 2KB, and Sector 2 = 4KB (shared with the LEA module). Each sector can be individually powered down in LPM3 and LPM4 to save leakage. Data is lost when sectors are powered down in LPM3 and LPM4. See [Table 9-47](#) for control and configuration registers.

9.10 Tiny RAM

Tiny RAM provides 22 bytes of RAM in addition to the complete RAM (see [Table 9-41](#)). This memory is always available, even in LPM3 and LPM4, while the complete RAM can be powered down in LPM3 and LPM4. Tiny RAM can be used to hold data or a very small stack when the complete RAM is powered down in LPM3 and LPM4. No memory is available in LPMx.5.

9.11 Memory Protection Unit (MPU) Including IP Encapsulation

The FRAM can be protected by the MPU from inadvertent CPU execution, read access, or write access. See [Table 9-67](#) for control and configuration registers. Features of the MPU include:

- IP encapsulation with programmable boundaries in steps of 1KB (prevents reads from "outside"; for example, through JTAG or by non-IP software).
- Main memory partitioning is programmable up to three segments in steps of 1KB.
- Access rights of each segment can be individually selected (main and information memory).
- Access violation flags with interrupt capability for easy servicing of access violations.

9.12 Peripherals

Peripherals are connected to the CPU through data, address, and control buses. The peripherals can be managed using all instructions. For complete module descriptions, see the [MSP430FR58xx](#), [MSP430FR59xx](#), and [MSP430FR6xx Family User's Guide](#).

9.12.1 Digital I/O

Up to nine 8-bit I/O ports are implemented (see [Table 9-52](#) through [Table 9-56](#) for control and configuration registers):

- All individual I/O bits are independently programmable.
- Any combination of input, output, and interrupt conditions is possible.
- Programmable pullup or pulldown on all ports.
- Edge-selectable interrupt and LPM3.5 and LPM4.5 wake-up input capability is available for all pins of ports P1 to P8.
- Read and write access to port control registers is supported by all instructions.
- Ports can be accessed byte-wise or word-wise in pairs.
- All pins of ports P1 to P8, and PJ support capacitive touch functionality.
- No cross-currents during start-up.

Note

Configuration of Digital I/Os After BOR Reset

To prevent any cross currents during start-up of the device, all port pins are high-impedance with Schmitt triggers and their module functions disabled. To enable the I/O functionality after a BOR reset, first configure the ports and then clear the LOCKLPM5 bit. For details, see the *Configuration After Reset* section of the *Digital I/O* chapter in the [MSP430FR58xx](#), [MSP430FR59xx](#), and [MSP430FR6xx Family User's Guide](#).

9.12.2 Oscillator and Clock System (CS)

The clock system includes support for a 32-kHz watch-crystal oscillator XT1 (LF), an internal very-low-power low-frequency oscillator (VLO), an integrated internal digitally controlled oscillator (DCO), and a high-frequency crystal oscillator XT2 (HF). The clock system module is designed to meet the requirements of both low system cost and low power consumption. A fail-safe mechanism exists for all crystal sources. See [Table 9-49](#) for control and configuration registers.

The clock system module provides the following clock signals:

- Auxiliary clock (ACLK). ACLK can be sourced from a 32-kHz watch crystal (LFXT1), the internal VLO, or a digital external low-frequency (<50 kHz) clock source.
- Main clock (MCLK), the system clock used by the CPU. MCLK can be sourced from a high-frequency crystal (HFXT2), the internal DCO, a 32-kHz watch crystal (LFXT1), the internal VLO, or a digital external clock source.
- Sub-Main clock (SMCLK), the subsystem clock used by the peripheral modules. SMCLK can be sourced by same sources made available to MCLK.

9.12.3 Power-Management Module (PMM)

The PMM includes an integrated voltage regulator that supplies the core voltage to the device. The PMM also includes supply voltage supervisor (SVS) and brownout protection. The brownout circuit provides the proper internal reset signal to the device during power on and power off. The SVS circuitry detects if the supply voltage drops below a safe level and below a user-selectable level. SVS circuitry is available on the primary and core supplies. See [Table 9-44](#) for control and configuration registers.

9.12.4 Hardware Multiplier (MPY)

The multiplication operation is supported by a dedicated peripheral module. The module performs operations with 32-, 24-, 16-, and 8-bit operands. The module supports signed multiplication, unsigned multiplication, signed multiply-and-accumulate, and unsigned multiply-and-accumulate operations. See [Table 9-65](#) for control and configuration registers.

9.12.5 Real-Time Clock (RTC_C)

The RTC_C module contains an integrated real-time clock (RTC) with the following features:

- Calendar mode with leap year correction
- General-purpose counter mode

The internal calendar compensates for months with fewer than 31 days and includes leap year correction. The RTC_C also supports flexible alarm functions and offset-calibration hardware. RTC operation is available in LPM3.5 modes to minimize power consumption. See [Table 9-64](#) for control and configuration registers.

9.12.6 Watchdog Timer (WDT_A)

The primary function of the WDT_A module is to perform a controlled system restart if a software problem occurs. If the selected time interval expires, a system reset is generated. If the watchdog function is not needed in an application, the module can be configured as an interval timer and can generate interrupts at selected time intervals. [Table 9-9](#) lists the clocks that can source WDT_A. See [Table 9-48](#) for control and configuration registers.

Table 9-9. WDT_A Clocks

WDTSEL	NORMAL OPERATION (WATCHDOG AND INTERVAL TIMER MODE)
00	SMCLK
01	ACLK
10	VLOCLK
11	LFMODCLK

9.12.7 System Module (SYS)

The SYS module manages many of the system functions within the device. These include power-on reset (POR) and power-up clear (PUC) handling, NMI source selection and management, reset interrupt vector generators (see [Table 9-10](#)), bootloader (BSL) entry mechanisms, and configuration management (device descriptors). The SYS module also includes a data exchange mechanism through JTAG called a JTAG mailbox that can be used in the application. See [Table 9-50](#) for control and configuration registers.

Table 9-10. System Module Interrupt Vector Registers

INTERRUPT VECTOR REGISTER	ADDRESS	INTERRUPT EVENT	VALUE	PRIORITY
SYSRSTIV, System Reset	019Eh	No interrupt pending	00h	
		Brownout (BOR)	02h	Highest
		RSTIFG RST/NMI (BOR)	04h	
		PMMSWBOR software BOR (BOR)	06h	
		LPMx.5 wake up (BOR)	08h	
		Security violation (BOR)	0Ah	
		Reserved	0Ch	
		SVSHIFG SVSH event (BOR)	0Eh	
		Reserved	10h	
		Reserved	12h	
		PMMSWPOR software POR (POR)	14h	
		WDTIFG watchdog timeout (PUC)	16h	
		WDTPW password violation (PUC)	18h	
		FRCTLPW password violation (PUC)	1Ah	
		Uncorrectable FRAM bit error detection (PUC)	1Ch	
		Peripheral area fetch (PUC)	1Eh	
		PMMPW PMM password violation (PUC)	20h	
		MPUPW MPU password violation (PUC)	22h	
		CSPW CS password violation (PUC)	24h	
		MPUSEGIIFG encapsulated IP memory segment violation (PUC)	26h	
		MPUSEGIIFG information memory segment violation (PUC)	28h	
MPUSEG1IFG segment 1 memory violation (PUC)	2Ah			
MPUSEG2IFG segment 2 memory violation (PUC)	2Ch			
MPUSEG3IFG segment 3 memory violation (PUC)	2Eh			
Reserved	30h to 3Eh	Lowest		
SYSSNIV, System NMI	019Ch	No interrupt pending	00h	
		Reserved	02h	Highest
		Uncorrectable FRAM bit error detection	04h	
		FRAM access time error	06h	
		MPUSEGIIFG encapsulated IP memory segment violation	08h	
		MPUSEGIIFG information memory segment violation	0Ah	
		MPUSEG1IFG segment 1 memory violation	0Ch	
		MPUSEG2IFG segment 2 memory violation	0Eh	
		MPUSEG3IFG segment 3 memory violation	10h	
		VMAIFG vacant memory access	12h	
		JMBINIFG JTAG mailbox input	14h	
		JMBOUTIFG JTAG mailbox output	16h	
		Correctable FRAM bit error detection	18h	
		FRAM write protection detection	1Ah	
		LEA time-out fault ⁽¹⁾	1Ch	
		LEA command fault ⁽¹⁾	1Eh	Lowest

Table 9-10. System Module Interrupt Vector Registers (continued)

INTERRUPT VECTOR REGISTER	ADDRESS	INTERRUPT EVENT	VALUE	PRIORITY
SYSUNIV, User NMI	019Ah	No interrupt pending	00h	
		NMIIFG NMI pin	02h	Highest
		OFIFG oscillator fault	04h	
		Reserved	06h	
		Reserved	08h	
		Reserved	0Ah to 1Eh	Lowest

(1) Reserved on MSP430FR596x.

9.12.8 DMA Controller

The DMA controller allows movement of data from one memory address to another without CPU intervention. For example, the DMA controller can be used to move data from the ADC12_B conversion memory to RAM. Using the DMA controller can increase the throughput of peripheral modules. The DMA controller reduces system power consumption by allowing the CPU to remain in sleep mode, without having to awaken to move data to or from a peripheral. See [Table 9-66](#) for control and configuration registers. [Table 9-11](#) lists the available DMA triggers.

Table 9-11. DMA Trigger Assignments

TRIGGER (1)	CHANNEL 0	CHANNEL 1	CHANNEL 2	CHANNEL 3	CHANNEL 4	CHANNEL 5
0	DMAREQ	DMAREQ	DMAREQ	DMAREQ	DMAREQ	DMAREQ
1	TA0CCR0 CCIFG	TA0CCR0 CCIFG	TA0CCR0 CCIFG	TA0CCR0 CCIFG	TA0CCR0 CCIFG	TA0CCR0 CCIFG
2	TA0CCR2 CCIFG	TA0CCR2 CCIFG	TA0CCR2 CCIFG	TA0CCR2 CCIFG	TA0CCR2 CCIFG	TA0CCR2 CCIFG
3	TA1CCR0 CCIFG	TA1CCR0 CCIFG	TA1CCR0 CCIFG	TA1CCR0 CCIFG	TA1CCR0 CCIFG	TA1CCR0 CCIFG
4	TA1CCR2 CCIFG	TA1CCR2 CCIFG	TA1CCR2 CCIFG	TA1CCR2 CCIFG	TA1CCR2 CCIFG	TA1CCR2 CCIFG
5	TA2CCR0 CCIFG	TA2CCR0 CCIFG	TA2CCR0 CCIFG	TA2CCR0 CCIFG	TA2CCR0 CCIFG	TA2CCR0 CCIFG
6	TA3CCR0 CCIFG	TA3CCR0 CCIFG	TA3CCR0 CCIFG	TA3CCR0 CCIFG	TA3CCR0 CCIFG	TA3CCR0 CCIFG
7	TB0CCR0 CCIFG	TB0CCR0 CCIFG	TB0CCR0 CCIFG	TB0CCR0 CCIFG	TB0CCR0 CCIFG	TB0CCR0 CCIFG
8	TB0CCR2 CCIFG	TB0CCR2 CCIFG	TB0CCR2 CCIFG	TB0CCR2 CCIFG	TB0CCR2 CCIFG	TB0CCR2 CCIFG
9	TA4CCR0 CCIFG	TA4CCR0 CCIFG	TA4CCR0 CCIFG	TA4CCR0 CCIFG	TA4CCR0 CCIFG	TA4CCR0 CCIFG
10	Reserved	Reserved	Reserved	Reserved	Reserved	Reserved
11	AES Trigger 0	AES Trigger 0	AES Trigger 0	AES Trigger 0	AES Trigger 0	AES Trigger 0
12	AES Trigger 1	AES Trigger 1	AES Trigger 1	AES Trigger 1	AES Trigger 1	AES Trigger 1
13	AES Trigger 2	AES Trigger 2	AES Trigger 2	AES Trigger 2	AES Trigger 2	AES Trigger 2
14	UCA0RXIFG	UCA0RXIFG	UCA0RXIFG	UCA2RXIFG	UCA2RXIFG	UCA2RXIFG
15	UCA0TXIFG	UCA0TXIFG	UCA0TXIFG	UCA2TXIFG	UCA2TXIFG	UCA2TXIFG
16	UCA1RXIFG	UCA1RXIFG	UCA1RXIFG	UCA3RXIFG	UCA3RXIFG	UCA3RXIFG
17	UCA1TXIFG	UCA1TXIFG	UCA1TXIFG	UCA3TXIFG	UCA3TXIFG	UCA3TXIFG
18	UCB0RXIFG (SPI) UCB0RXIFG0 (I ² C)	UCB0RXIFG (SPI) UCB0RXIFG0 (I ² C)	UCB0RXIFG (SPI) UCB0RXIFG0 (I ² C)	UCB1RXIFG (SPI) UCB1RXIFG0 (I ² C)	UCB2RXIFG (SPI) UCB2RXIFG0 (I ² C)	UCB3RXIFG (SPI) UCB3RXIFG0 (I ² C)
19	UCB0TXIFG (SPI) UCB0TXIFG0 (I ² C)	UCB0TXIFG (SPI) UCB0TXIFG0 (I ² C)	UCB0TXIFG (SPI) UCB0TXIFG0 (I ² C)	UCB1TXIFG (SPI) UCB1TXIFG0 (I ² C)	UCB2TXIFG (SPI) UCB2TXIFG0 (I ² C)	UCB3TXIFG (SPI) UCB3TXIFG0 (I ² C)
20	UCB0RXIFG1 (I ² C)	UCB0RXIFG1 (I ² C)	UCB0RXIFG1 (I ² C)	UCB1RXIFG1 (I ² C)	UCB2RXIFG1 (I ² C)	UCB3RXIFG1 (I ² C)
21	UCB0TXIFG1 (I ² C)	UCB0TXIFG1 (I ² C)	UCB0TXIFG1 (I ² C)	UCB1TXIFG1 (I ² C)	UCB2TXIFG1 (I ² C)	UCB3TXIFG1 (I ² C)
22	UCB0RXIFG2 (I ² C)	UCB0RXIFG2 (I ² C)	UCB0RXIFG2 (I ² C)	UCB1RXIFG2 (I ² C)	UCB2RXIFG2 (I ² C)	UCB3RXIFG2 (I ² C)
23	UCB0TXIFG2 (I ² C)	UCB0TXIFG2 (I ² C)	UCB0TXIFG2 (I ² C)	UCB1TXIFG2 (I ² C)	UCB2TXIFG2 (I ² C)	UCB3TXIFG2 (I ² C)
24	UCB0RXIFG3 (I ² C)	UCB0RXIFG3 (I ² C)	UCB0RXIFG3 (I ² C)	UCB1RXIFG3 (I ² C)	UCB2RXIFG3 (I ² C)	UCB3RXIFG3 (I ² C)
25	UCB0TXIFG3 (I ² C)	UCB0TXIFG3 (I ² C)	UCB0TXIFG3 (I ² C)	UCB1TXIFG3 (I ² C)	UCB2TXIFG3 (I ² C)	UCB3TXIFG3 (I ² C)
26	ADC12 end of conversion	ADC12 end of conversion	ADC12 end of conversion	ADC12 end of conversion	ADC12 end of conversion	ADC12 end of conversion
27	LEA ready ⁽²⁾	LEA ready ⁽²⁾	LEA ready ⁽²⁾	LEA ready ⁽²⁾	LEA ready ⁽²⁾	LEA ready ⁽²⁾

Table 9-11. DMA Trigger Assignments (continued)

TRIGGER (1)	CHANNEL 0	CHANNEL 1	CHANNEL 2	CHANNEL 3	CHANNEL 4	CHANNEL 5
28	Reserved	Reserved	Reserved	Reserved	Reserved	Reserved
29	MPY ready	MPY ready	MPY ready	MPY ready	MPY ready	MPY ready
30	DMA2IFG	DMA0IFG	DMA1IFG	DMA5IFG	DMA3IFG	DMA4IFG
31	DMAE0	DMAE0	DMAE0	DMAE0	DMAE0	DMAE0

- (1) If a reserved trigger source is selected, no trigger is generated.
 (2) Reserved on MSP430FR596x.

9.12.9 Enhanced Universal Serial Communication Interface (eUSCI)

The eUSCI modules are used for serial data communication. The eUSCI module supports synchronous communication protocols such as SPI (3 pin or 4 pin) and I²C, and asynchronous communication protocols such as UART, enhanced UART with automatic baud-rate detection, and IrDA.

The eUSCI_An module provides support for SPI (3 pin or 4 pin), UART, enhanced UART, and IrDA.

The eUSCI_Bn module provides support for SPI (3 pin or 4 pin) and I²C.

Up to four eUSCI_A modules and up to four eUSCI_B modules are implemented. See [Table 9-68](#) through [Table 9-75](#) for control and configuration registers.

9.12.10 TA0, TA1, and TA4

TA0, TA1, and TA4 are 16-bit timers and counters (Timer_A type) with three (TA0 and TA1) or two (TA4) capture/compare registers each. Each timer can support multiple captures or compares, PWM outputs, and interval timing (see [Table 9-12](#), [Table 9-13](#), and [Table 9-14](#)). Each timer has extensive interrupt capabilities. Interrupts may be generated from the counter on overflow conditions and from each of the capture/compare registers. See [Table 9-57](#), [Table 9-58](#), and [Table 9-76](#) for control and configuration registers.

Table 9-12. TA0 Signal Connections

INPUT PORT PIN	DEVICE INPUT SIGNAL	MODULE INPUT SIGNAL	MODULE BLOCK	MODULE OUTPUT SIGNAL	DEVICE OUTPUT SIGNAL	OUTPUT PORT PIN
P1.2	TA0CLK	TACLK	Timer	N/A	N/A	
	ACLK (internal)	ACLK				
	SMCLK (internal)	SMCLK				
P1.2	$\overline{\text{TA0CLK}}$	INCLK				
P1.6	TA0.0	CC10A	CCR0	TA0	TA0.0	P1.6
P2.3	TA0.0	CC10B				P2.3
	DVSS	GND				
	DVCC	V _{CC}				
P1.0	TA0.1	CC11A	CCR1	TA1	TA0.1	P1.0
	COUT (internal)	CC11B				ADC12(internal) ⁽¹⁾ ADC12SHSx = {1}
	DVSS	GND				
	DVCC	V _{CC}				
P1.1	TA0.2	CC12A	CCR2	TA2	TA0.2	P1.1
	ACLK (internal)	CC12B				
	DVSS	GND				
	DVCC	V _{CC}				

- (1) Only on devices with ADC

Table 9-13. TA1 Signal Connections

INPUT PORT PIN	DEVICE INPUT SIGNAL	MODULE INPUT SIGNAL	MODULE BLOCK	MODULE OUTPUT SIGNAL	DEVICE OUTPUT SIGNAL	OUTPUT PORT PIN
P1.1	TA1CLK	TACLK	Timer	N/A	N/A	
	ACLK (internal)	ACLK				
	SMCLK (internal)	SMCLK				
P1.1	$\overline{\text{TA1CLK}}$	INCLK				
P1.7	TA1.0	CCI0A	CCR0	TA0	TA1.0	P1.7
P2.4	TA1.0	CCI0B				P2.4
	DVSS	GND				
	DVCC	V _{CC}				
P1.2	TA1.1	CCI1A	CCR1	TA1	TA1.1	P1.2
	COOUT (internal)	CCI1B				ADC12(internal) ⁽¹⁾ ADC12SHSx = {4}
	DVSS	GND				
	DVCC	V _{CC}				
P1.3	TA1.2	CCI2A	CCR2	TA2	TA1.2	P1.3
	ACLK (internal)	CCI2B				
	DVSS	GND				
	DVCC	V _{CC}				

(1) Only on devices with ADC

Table 9-14. TA4 Signal Connections

INPUT PORT PIN	DEVICE INPUT SIGNAL	MODULE INPUT SIGNAL	MODULE BLOCK	MODULE OUTPUT SIGNAL	DEVICE OUTPUT SIGNAL	OUTPUT PORT PIN
P5.2	TA4CLK	TACLK	Timer	N/A	N/A	
	ACLK (internal)	ACLK				
	SMCLK (internal)	SMCLK				
P5.2	$\overline{\text{TA4CLK}}$	INCLK				
P5.6	TA4.0	CCI0A	CCR0	TA0	TA4.0	
P7.4	TA4.0	CCI0B				
	DVSS	GND				
	DVCC	V _{CC}				
P5.7	TA4.1	CCI1A	CCR1	TA1	TA4.1	
P7.3	TA4.1	CCI1B				ADC12(internal) ⁽¹⁾ ADC12SHSx = {7}
	DVSS	GND				
	DVCC	V _{CC}				

9.12.11 TA2 and TA3

TA2 and TA3 are 16-bit timers and counters (Timer_A type) with two capture/compare registers each and with internal connections only. Each timer can support multiple captures or compares, PWM outputs, and interval timing (see [Table 9-15](#) and [Table 9-16](#)). Each timer has extensive interrupt capabilities. Interrupts may be generated from the counter on overflow conditions and from each of the capture/compare registers. See [Table 9-60](#) and [Table 9-62](#) for control and configuration registers.

Table 9-15. TA2 Signal Connections

DEVICE INPUT SIGNAL	MODULE INPUT NAME	MODULE BLOCK	MODULE OUTPUT SIGNAL	DEVICE OUTPUT SIGNAL
COUT (internal)	TACLK	Timer	N/A	
ACLK (internal)	ACLK			
SMCLK (internal)	SMCLK			
From Capacitive Touch I/O 0 (internal)	INCLK			
TA3 CCR0 output (internal)	CCI0A	CCR0	TA0	TA3 CCI0A input
ACLK (internal)	CCI0B			
DVSS	GND			
DVCC	V _{CC}			
From Capacitive Touch I/O 0 (internal)	CCI1A	CCR1	TA1	ADC12(internal) ⁽¹⁾ ADC12SHSx = {5}
COUT (internal)	CCI1B			
DVSS	GND			
DVCC	V _{CC}			

(1) Only on devices with ADC

Table 9-16. TA3 Signal Connections

DEVICE INPUT SIGNAL	MODULE INPUT NAME	MODULE BLOCK	MODULE OUTPUT SIGNAL	DEVICE OUTPUT SIGNAL
COUT (internal)	TACLK	Timer	N/A	
ACLK (internal)	ACLK			
SMCLK (internal)	SMCLK			
From Capacitive Touch I/O 1 (internal)	INCLK			
TA2 CCR0 output (internal)	CCI0A	CCR0	TA0	TA2 CCI0A input
ACLK (internal)	CCI0B			
DVSS	GND			
DVCC	V _{CC}			
From Capacitive Touch I/O 1 (internal)	CCI1A	CCR1	TA1	ADC12(internal) ⁽¹⁾ ADC12SHSx = {6}
COUT (internal)	CCI1B			
DVSS	GND			
DVCC	V _{CC}			

(1) Only on devices with ADC

9.12.12 TB0

TB0 is a 16-bit timer and counter (Timer_B type) with seven capture/compare registers. TB0 can support multiple captures or compares, PWM outputs, and interval timing (see [Table 9-17](#)). TB0 has extensive interrupt capabilities. Interrupts may be generated from the counter on overflow conditions and from each of the capture/compare registers. See [Table 9-59](#) for control and configuration registers.

Table 9-17. TB0 Signal Connections

INPUT PORT PIN	DEVICE INPUT SIGNAL	MODULE INPUT SIGNAL	MODULE BLOCK	MODULE OUTPUT SIGNAL	DEVICE OUTPUT SIGNAL	OUTPUT PORT PIN
P2.0	TB0CLK	TBCLK	Timer	N/A	N/A	
	ACLK (internal)	ACLK				
	SMCLK (internal)	SMCLK				
P2.0	$\overline{\text{TB0CLK}}$	INCLK				
P2.1	TB0.0	CCI0A	CCR0	TB0	TB0.0	P2.1
P2.5	TB0.0	CCI0B				P2.5
	DVSS	GND				ADC12 (internal) ⁽¹⁾ ADC12SHSx = {2}
	DVCC	V _{CC}				
P1.4	TB0.1	CCI1A	CCR1	TB1	TB0.1	P1.4
	COU _T (internal)	CCI1B				P2.6
	DVSS	GND				ADC12 (internal) ⁽¹⁾ ADC12SHSx = {3}
	DVCC	V _{CC}				
P1.5	TB0.2	CCI2A	CCR2	TB2	TB0.2	P1.5
	ACLK (internal)	CCI2B				P2.2
	DVSS	GND				
	DVCC	V _{CC}				
P3.4	TB0.3	CCI3A	CCR3	TB3	TB0.3	P3.4
P1.6	TB0.3	CCI3B				P1.6
	DVSS	GND				
	DVCC	V _{CC}				
P3.5	TB0.4	CCI4A	CCR4	TB4	TB0.4	P3.5
P1.7	TB0.4	CCI4B				P1.7
	DVSS	GND				
	DVCC	V _{CC}				
P3.6	TB0.5	CCI5A	CCR5	TB5	TB0.5	P3.6
P4.4	TB0.5	CCI5B				P4.4
	DVSS	GND				
	DVCC	V _{CC}				
P3.7	TB0.6	CCI6A	CCR6	TB6	TB0.6	P3.7
P2.0	TB0.6	CCI6B				P2.0
	DVSS	GND				
	DVCC	V _{CC}				

(1) Only on devices with ADC

9.12.13 ADC12_B

The ADC12_B module supports fast 12-bit analog-to-digital conversions with differential and single-ended inputs. The module implements a 12-bit SAR core, sample select control, a reference generator, and a conversion result buffer. A window comparator with lower and upper limits allows CPU-independent result monitoring with three window comparator interrupt flags. See [Table 9-77](#) for control and configuration registers.

[Table 9-18](#) summarizes the available external trigger sources.

[Table 9-19](#) lists the available multiplexing between internal and external analog inputs.

Table 9-18. ADC12_B Trigger Signal Connections

ADC12SHSx		CONNECTED TRIGGER SOURCE
BINARY	DECIMAL	
000	0	Software (ADC12SC)
001	1	TA0 CCR1 output
010	2	TB0 CCR0 output
011	3	TB0 CCR1 output
100	4	TA1 CCR1 output
101	5	TA2 CCR1 output
110	6	TA3 CCR1 output
111	7	TA4 CCR1 output

Table 9-19. ADC12_B External and Internal Signal Mapping

CONTROL BIT IN ADC12CTL3 REGISTER	EXTERNAL ADC INPUT (CONTROL BIT = 0)	INTERNAL ADC INPUT (CONTROL BIT = 1)
ADC12BATMAP	A31	Battery monitor
ADC12TCMAP	A30	Temperature sensor
ADC12CH0MAP	A29	N/A ⁽¹⁾
ADC12CH1MAP	A28	N/A ⁽¹⁾
ADC12CH2MAP	A27	N/A ⁽¹⁾
ADC12CH3MAP	A26	N/A ⁽¹⁾

(1) N/A = No internal signal is available on this device.

9.12.14 Comparator_E

The primary function of the Comparator_E module is to support precision slope analog-to-digital conversions, battery voltage supervision, and monitoring of external analog signals. See [Table 9-78](#) for control and configuration registers.

9.12.15 CRC16

The CRC16 module produces a signature based on a sequence of entered data values and can be used for data checking purposes. The CRC16 module signature is based on the CRC-CCITT standard. See [Table 9-46](#) for control and configuration registers.

9.12.16 CRC32

The CRC32 module produces a signature based on a sequence of entered data values and can be used for data checking purposes. The CRC32 signature is based on the ISO 3309 standard. See [Table 9-79](#) for control and configuration registers.

9.12.17 AES256 Accelerator

The AES accelerator module performs encryption and decryption of 128-bit data with 128-, 192-, or 256-bit keys according to the Advanced Encryption Standard (AES) (FIPS PUB 197) in hardware. See [Table 9-80](#) for control and configuration registers.

9.12.18 True Random Seed

The Device Descriptor Information (TLV) section contains a 128-bit true random seed that can be used to implement a deterministic random number generator.

9.12.19 Shared Reference (REF)

The REF module generates all critical reference voltages that can be used by the various analog peripherals in the device.

9.12.20 Embedded Emulation

9.12.20.1 Embedded Emulation Module (EEM) (S Version)

The EEM supports real-time in-system debugging. The S version of the EEM has the following features:

- Three hardware triggers or breakpoints on memory access
- One hardware trigger or breakpoint on CPU register write access
- Up to four hardware triggers can be combined to form complex triggers or breakpoints
- One cycle counter
- Clock control on module level

9.12.20.2 EnergyTrace++ Technology

The devices implement circuitry to support EnergyTrace++ technology. The EnergyTrace++ technology allows you to observe information about the internal states of the microcontroller. These states include the CPU program counter (PC), the ON or OFF status of the peripherals and the system clocks (regardless of the clock source), and the low-power mode currently in use. These states can always be read by a debug tool, even when the microcontroller sleeps in LPMx.5 modes.

The activity of the following modules can be observed:

- LEA is running (MSP430FR599x only).
- MPY is calculating.
- WDT is counting.
- RTC is counting.
- ADC: a sequence, sample, or conversion is active.
- REF: REFBG or REFGEN active and BG in static mode.
- COMP is on.
- AES is encrypting or decrypting.
- eUSCI_A0 is transferring (receiving or transmitting) data.
- eUSCI_A1 is transferring (receiving or transmitting) data.
- eUSCI_A2 is transferring (receiving or transmitting) data.
- eUSCI_A3 is transferring (receiving or transmitting) data.
- eUSCI_B0 is transferring (receiving or transmitting) data.
- eUSCI_B1 is transferring (receiving or transmitting) data.
- eUSCI_B2 is transferring (receiving or transmitting) data.
- eUSCI_B3 is transferring (receiving or transmitting) data.
- TB0 is counting.
- TA0 is counting.
- TA1 is counting.
- TA2 is counting.
- TA3 is counting.
- TA4 is counting.

9.13 Input/Output Diagrams

9.13.1 Capacitive Touch Functionality on Ports P1 to P8, and PJ

All port pins provide the Capacitive Touch functionality (see [Figure 9-2](#)). The Capacitive Touch functionality is controlled using the Capacitive Touch I/O control registers CAPTIO0CTL and CAPTIO1CTL as described in the [MSP430FR58xx, MSP430FR59xx, and MSP430FR6xx Family User's Guide](#). The Capacitive Touch functionality is not shown in the individual pin schematics in the following sections.

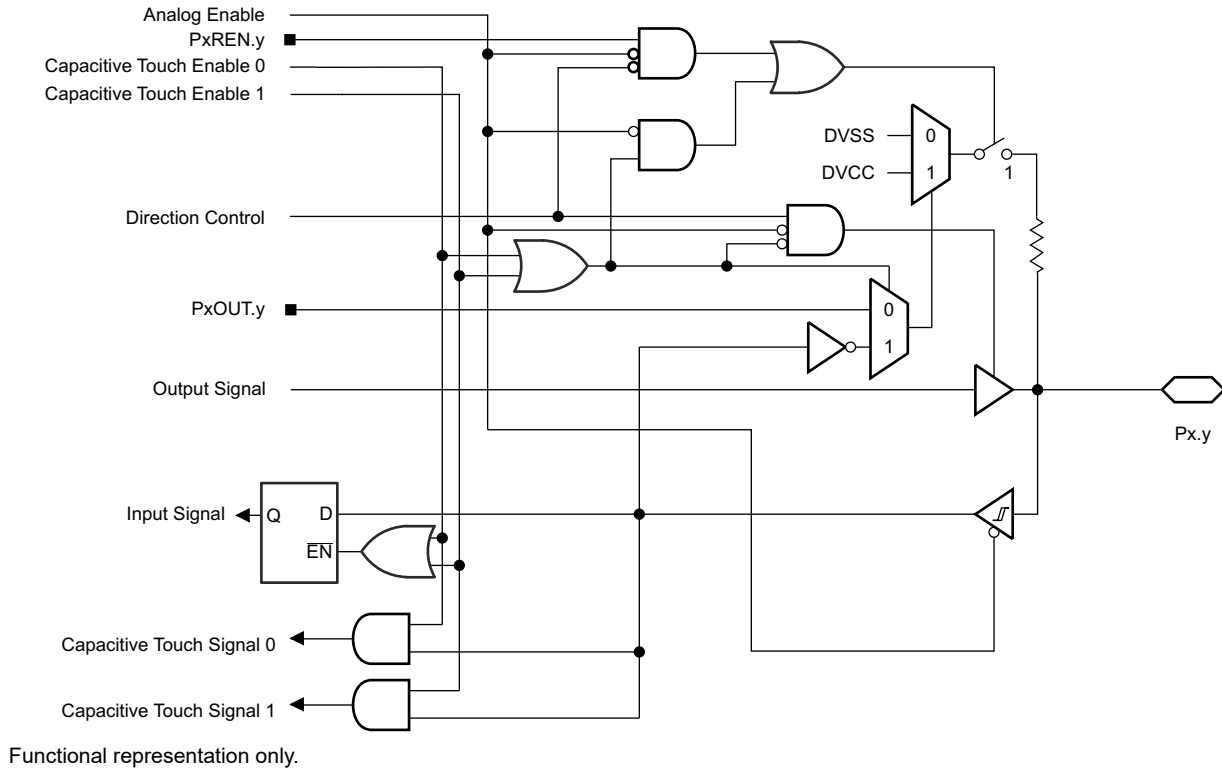
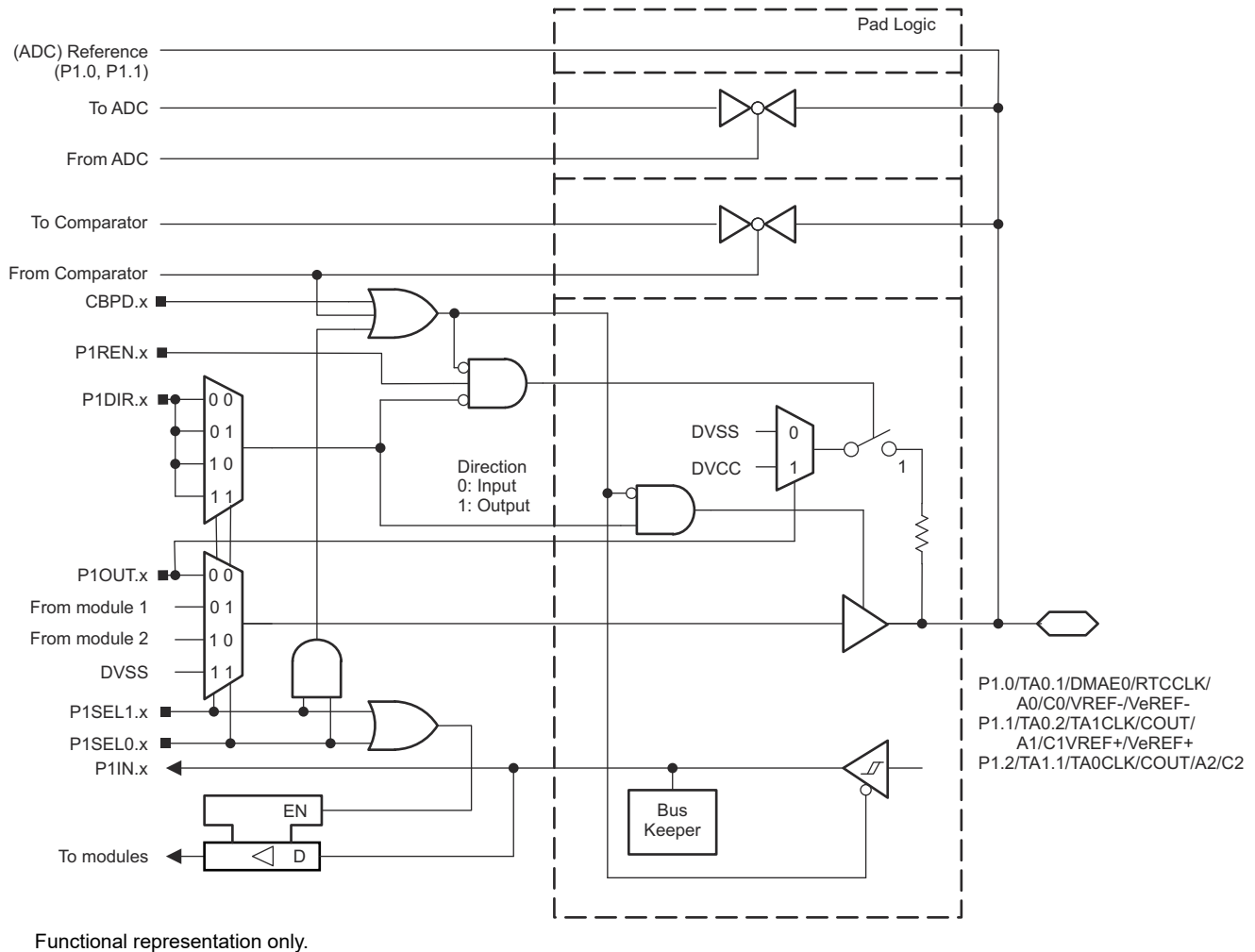

Figure 9-2. Capacitive Touch Functionality on Ports

9.13.2 Port P1 (P1.0 to P1.2) Input/Output With Schmitt Trigger

Figure 9-3 shows the port diagram. Table 9-20 summarizes the selection of the pin functions.



Functional representation only.

Figure 9-3. Port P1 (P1.0 to P1.2) Diagram

Table 9-20. Port P1 (P1.0 to P1.2) Pin Functions

PIN NAME (P1.x)	x	FUNCTION	CONTROL BITS AND SIGNALS ⁽¹⁾		
			P1DIR.x	P1SEL1.x	P1SEL0.x
P1.0/TA0.1/DMAE0/RTCCLK/A0/C0/ VREF-/VeREF-	0	P1.0 (I/O)	0 = Input, 1 = Output	0	0
		TA0.CCI1A	0	0	1
		TA0.1	1		
		DMAE0	0	1	0
		RTCCLK ⁽⁴⁾	1		
		A0, C0, VREF-, VeREF- ^{(2) (3)}	X	1	1
P1.1/TA0.2/TA1CLK/COUT/A1/C1/ VREF +/VeREF+	1	P1.1 (I/O)	0 = Input, 1 = Output	0	0
		TA0.CCI2A	0	0	1
		TA0.2	1		
		TA1CLK	0	1	0
		COUT ⁽⁵⁾	1		
		A1, C1, VREF+, VeREF+ ^{(2) (3)}	X	1	1
P1.2/TA1.1/TA0CLK/COUT/A2/C2	2	P1.2 (I/O)	0 = Input, 1 = Output	0	0
		TA1.CCI1A	0	0	1
		TA1.1	1		
		TA0CLK	0	1	0
		COUT ⁽⁵⁾	1		
		A2, C2 ^{(2) (3)}	X	1	1

- (1) X = Don't care
- (2) Setting P1SEL1.x and P1SEL0.x disables the output driver and the input Schmitt trigger to prevent parasitic cross currents when applying analog signals.
- (3) Setting the CEPDx bit of the comparator disables the output driver and the input Schmitt trigger to prevent parasitic cross currents when applying analog signals. Selecting the Cx input pin to the comparator multiplexer with the input select bits in the comparator module automatically disables output driver and input buffer for that pin, regardless of the state of the associated CEPDx bit.
- (4) Do not use this pin as RTCCLK output if the DMAE0 functionality is used on any other pin. Select an alternate RTCCLK output pin.
- (5) Do not use this pin as COUT output if the TA1CLK functionality is used on any other pin. Select an alternate COUT output pin.

9.13.3 Port P1 (P1.3 to P1.5) Input/Output With Schmitt Trigger

Figure 9-4 shows the port diagram. Table 9-21 summarizes the selection of the pin functions.

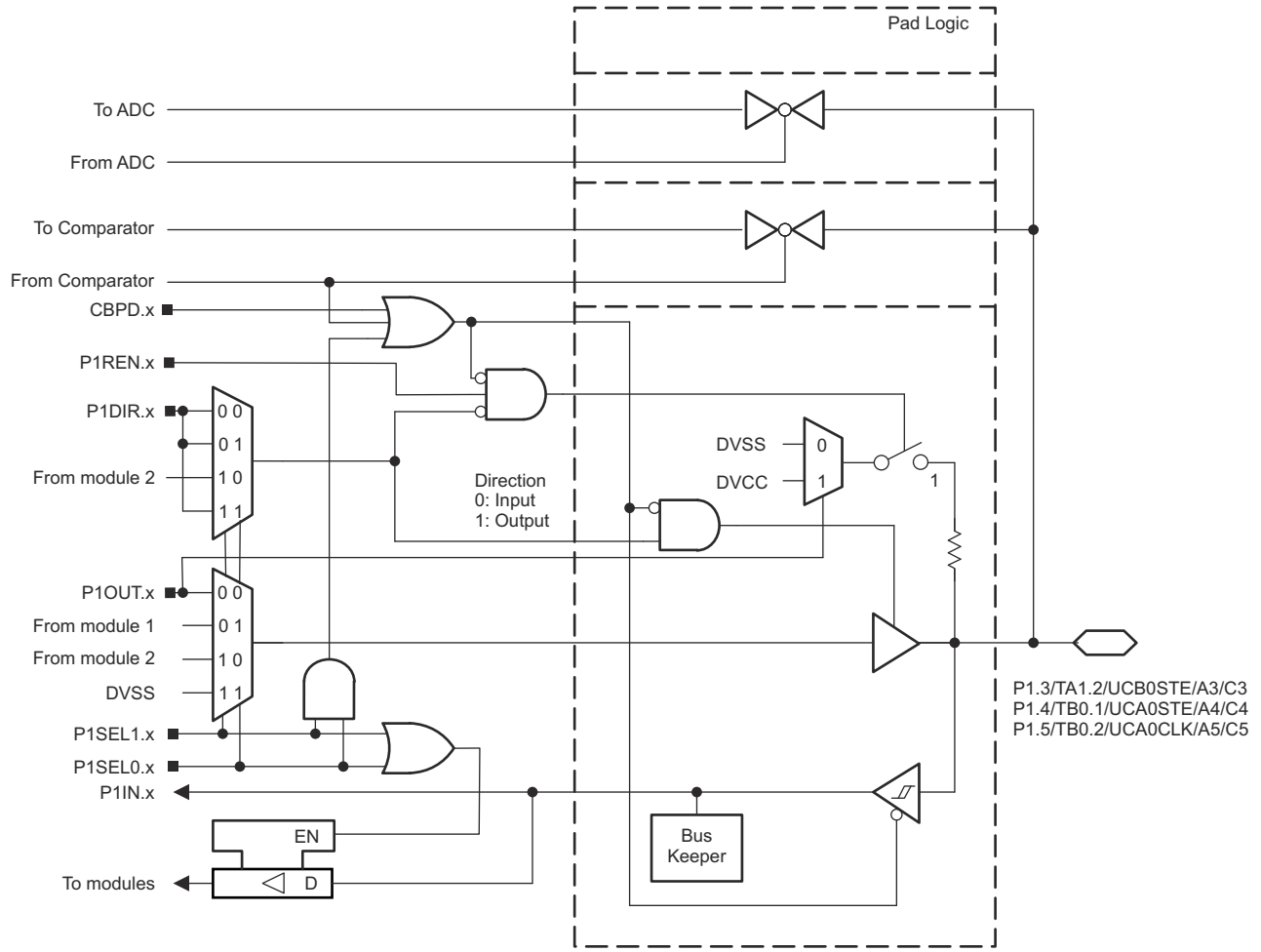

Functional representation only.

Figure 9-4. Port P1 (P1.3 to P1.5) Diagram

Table 9-21. Port P1 (P1.3 to P1.5) Pin Functions

PIN NAME (P1.x)	x	FUNCTION	CONTROL BITS AND SIGNALS ⁽¹⁾		
			P1DIR.x	P1SEL1.x	P1SEL0.x
P1.3/TA1.2/UCB0STE/A3/C3	3	P1.3 (I/O)	0 = Input, 1 = Output	0	0
		TA1.CCI2A	0	0	1
		TA1.2	1		
		UCB0STE	X ⁽²⁾	1	0
		A3, C3 ^{(4) (5)}	X	1	1
P1.4/TB0.1/UCA0STE/A4/C4	4	P1.4 (I/O)	0 = Input, 1 = Output	0	0
		TB0.CCI1A	0	0	1
		TB0.1	1		
		UCA0STE	X ⁽³⁾	1	0
		A4, C4 ^{(4) (5)}	X	1	1
P1.5/TB0.2/UCA0CLK/A5/C5	5	P1.5 (I/O)	0 = Input, 1 = Output	0	0
		TB0.CCI2A	0	0	1
		TB0.2	1		
		UCA0CLK	X ⁽³⁾	1	0
		A5, C5 ^{(4) (5)}	X	1	1

- (1) X = Don't care
- (2) Direction controlled by eUSCI_B0 module.
- (3) Direction controlled by eUSCI_A0 module.
- (4) Setting P1SEL1.x and P1SEL0.x disables the output driver and the input Schmitt trigger to prevent parasitic cross currents when applying analog signals.
- (5) Setting the CEPDx bit of the comparator disables the output driver and the input Schmitt trigger to prevent parasitic cross currents when applying analog signals. Selecting the Cx input pin to the comparator multiplexer with the input select bits in the comparator module automatically disables output driver and input buffer for that pin, regardless of the state of the associated CEPDx bit.

9.13.4 Port P1 (P1.6 and P1.7) Input/Output With Schmitt Trigger

Figure 9-5 shows the port diagram. Table 9-22 summarizes the selection of the pin functions.

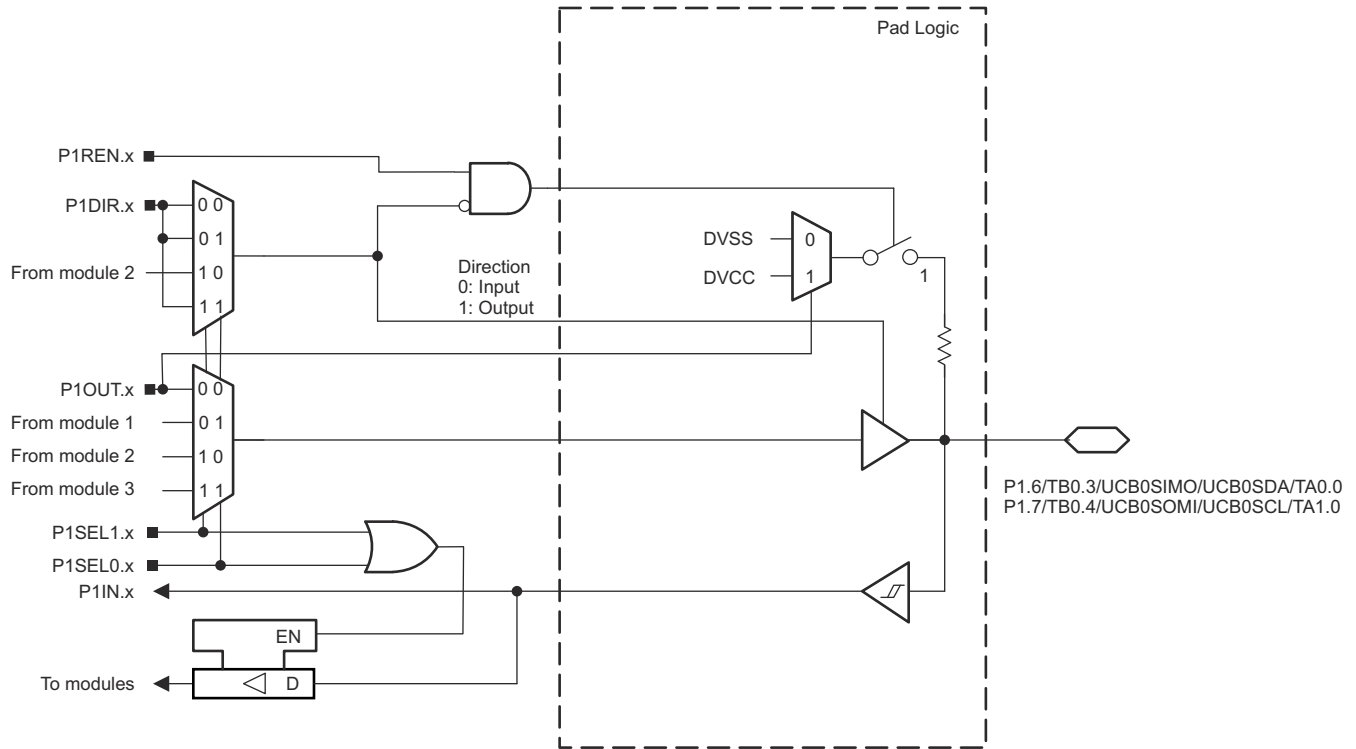

Functional representation only.

Figure 9-5. Port P1 (P1.6 and P1.7) Diagram

Table 9-22. Port P1 (P1.6 and P1.7) Pin Functions

PIN NAME (P1.x)	x	FUNCTION	CONTROL BITS AND SIGNALS ⁽¹⁾		
			P1DIR.x	P1SEL1.x	P1SEL0.x
P1.6/TB0.3/UCB0SIMO/UCB0SDA/TA0.0	6	P1.6 (I/O)	0 = Input, 1 = Output	0	0
		TB0.CCI3B	0	0	1
		TB0.3	1		
		UCB0SIMO/UCB0SDA	X ⁽²⁾	1	0
		TA0.CCI0A	0	1	1
		TA0.0	1		
P1.7/TB0.4/UCB0SOMI/UCB0SCL/TA1.0	7	P1.7 (I/O)	0 = Input, 1 = Output	0	0
		TB0.CCI4B	0	0	1
		TB0.4	1		
		UCB0SOMI/UCB0SCL	X ⁽²⁾	1	0
		TA1.CCI0A	0	1	1
		TA1.0	1		

(1) X = Don't care

(2) Direction controlled by eUSCI_B0 module.

9.13.5 Port P2 (P2.0 to P2.2) Input/Output With Schmitt Trigger

Figure 9-6 shows the port diagram. Table 9-23 summarizes the selection of the pin functions.

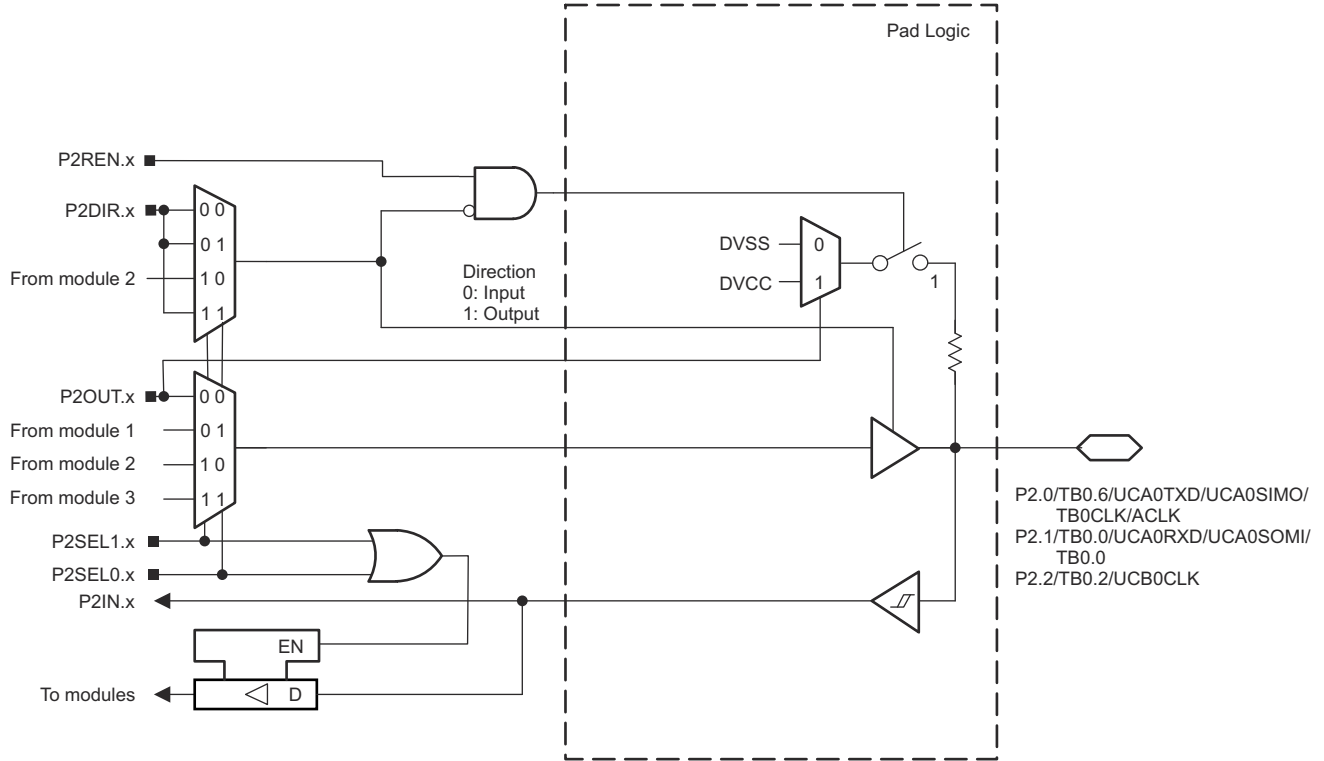

Functional representation only.

Figure 9-6. Port P2 (P2.0 to P2.2) Diagram

Table 9-23. Port P2 (P2.0 to P2.2) Pin Functions

PIN NAME (P2.x)	x	FUNCTION	CONTROL BITS AND SIGNALS ⁽¹⁾		
			P2DIR.x	P2SEL1.x	P2SEL0.x
P2.0/TB0.6/UCA0TXD/UCA0SIMO/ TB0CLK/ACLK	0	P2.0 (I/O)	0 = Input, 1 = Output	0	0
		TB0.CCI6B	0	0	1
		TB0.6	1		
		UCA0TXD/UCA0SIMO	X ⁽²⁾	1	0
		TB0CLK	0	1	1
		ACLK ⁽⁴⁾	1		
P2.1/TB0.0/UCA0RXD/UCA0SOMI	1	P2.1 (I/O)	0 = Input, 1 = Output	0	0
		TB0.CCI0A	0	X	1
		TB0.0	1		
		UCA0RXD/UCA0SOMI	X ⁽²⁾	1	0
P2.2/TB0.2/UCB0CLK	2	P2.2 (I/O)	0 = Input, 1 = Output	0	0
		N/A	0	0	1
		TB0.2	1		
		UCB0CLK	X ⁽³⁾	1	0
		N/A	0	1	1
		Internally tied to DVSS	1		

- (1) X = Don't care
(2) Direction controlled by eUSCI_A0 module.
(3) Direction controlled by eUSCI_B0 module.
(4) Do not use this pin as ACLK output if the TB0CLK functionality is used on any other pin. Select an alternate ACLK output pin.

9.13.6 Port P2 (P2.3 and P2.4) Input/Output With Schmitt Trigger

Figure 9-7 shows the port diagram. Table 9-24 summarizes the selection of the pin functions.

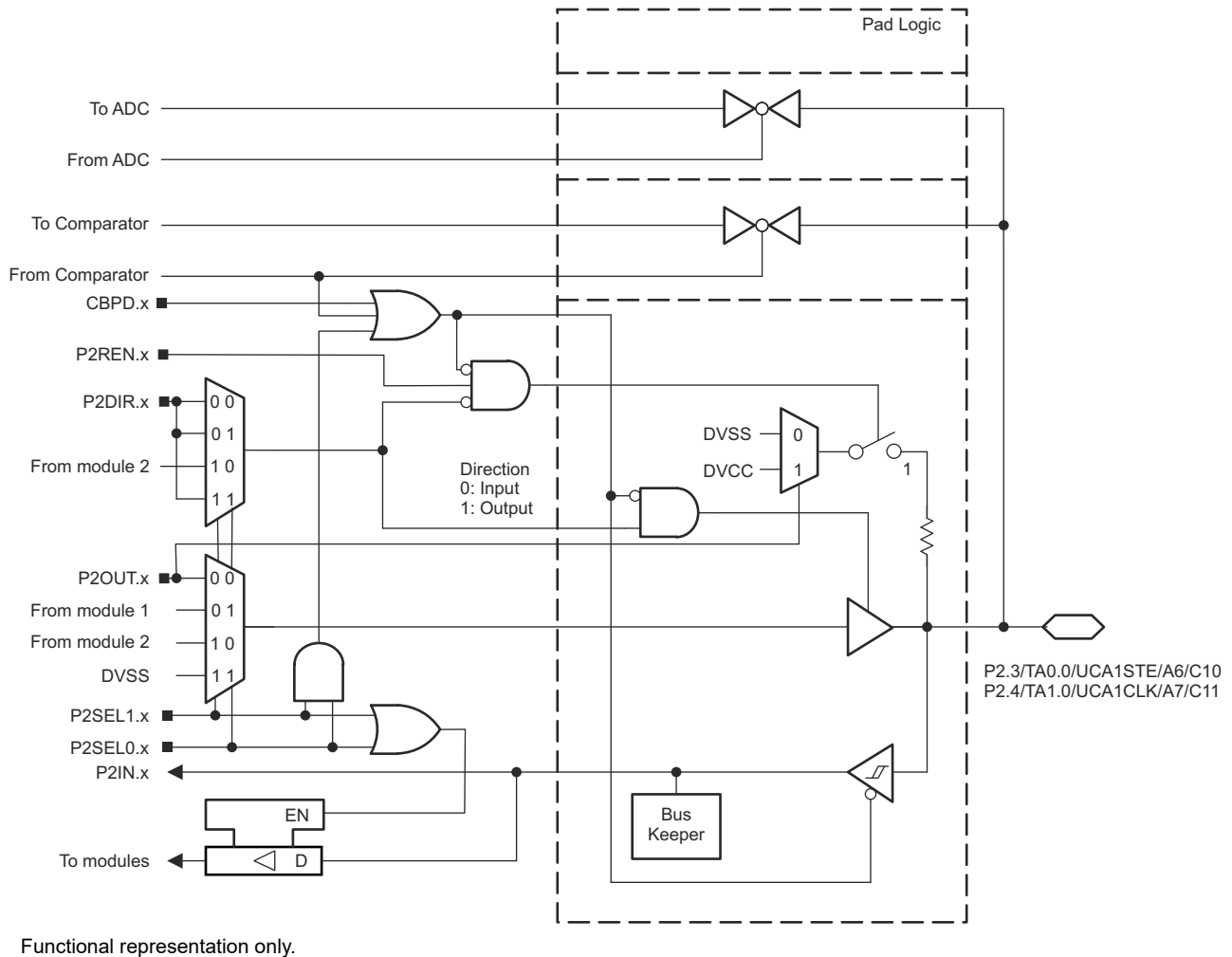

Functional representation only.

Figure 9-7. Port P2 (P2.3 and P2.4) Diagram

Table 9-24. Port P2 (P2.3 and P2.4) Pin Functions

PIN NAME (P2.x)	x	FUNCTION	CONTROL BITS AND SIGNALS ⁽¹⁾		
			P2DIR.x	P2SEL1.x	P2SEL0.x
P2.3/TA0.0/UCA1STE/A6/C10	3	P2.3 (I/O)	0 = Input, 1 = Output	0	0
		TA0.CCI0B	0	0	1
		TA0.0	1		
		UCA1STE	X ⁽²⁾	1	0
		A6, C10 ^{(3) (4)}	X	1	1
P2.4/TA1.0/UCA1CLK/A7/C11	4	P2.4 (I/O)	0 = Input, 1 = Output	0	0
		TA1.CCI0B	0	0	1
		TA1.0	1		
		UCA1CLK	X ⁽²⁾	1	0
		A7, C11 ^{(3) (4)}	X	1	1

- (1) X = Don't care
- (2) Direction controlled by eUSCI_A1 module.
- (3) Setting P2SEL1.x and P2SEL0.x disables the output driver and the input Schmitt trigger to prevent parasitic cross currents when applying analog signals.
- (4) Setting the CEPDx bit of the comparator disables the output driver and the input Schmitt trigger to prevent parasitic cross currents when applying analog signals. Selecting the Cx input pin to the comparator multiplexer with the input select bits in the comparator module automatically disables output driver and input buffer for that pin, regardless of the state of the associated CEPDx bit.

9.13.7 Port P2 (P2.5 and P2.6) Input/Output With Schmitt Trigger

Figure 9-8 shows the port diagram. Table 9-25 summarizes the selection of the pin functions.

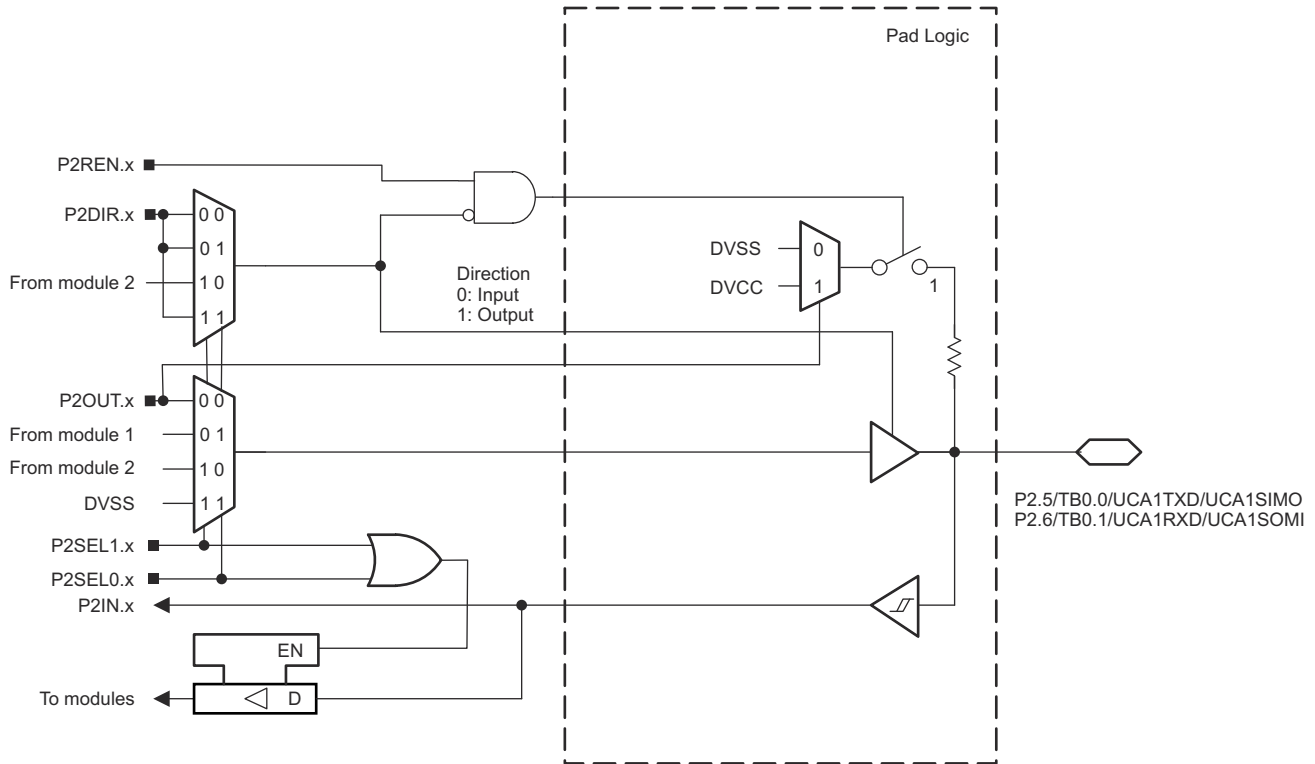

Functional representation only.

Figure 9-8. Port P2 (P2.5 and P2.6) Diagram

Table 9-25. Port P2 (P2.5 and P2.6) Pin Functions

PIN NAME (P2.x)	x	FUNCTION	CONTROL BITS AND SIGNALS ⁽¹⁾		
			P2DIR.x	P2SEL1.x	P2SEL0.x
P2.5/TB0.0/UCA1TXD/UCA1SIMO	5	P2.5(I/O)	0 = Input, 1 = Output	0	0
		TB0.CCI0B	0	0	1
		TB0.0	1		
		UCA1TXD/UCA1SIMO	X ⁽²⁾	1	0
		N/A	0	1	1
		Internally tied to DVSS	1		
P2.6/TB0.1/UCA1RXD/UCA1SOMI	6	P2.6(I/O)	0 = Input, 1 = Output	0	0
		N/A	0	0	1
		TB0.1	1		
		UCA1RXD/UCA1SOMI	X ⁽²⁾	1	0
		N/A	0	1	1
		Internally tied to DVSS	1		

(1) X = Don't care

(2) Direction controlled by eUSCI_A1 module.

9.13.8 Port P2 (P2.7) Input/Output With Schmitt Trigger

Figure 9-9 shows the port diagram. Table 9-26 summarizes the selection of the pin functions.

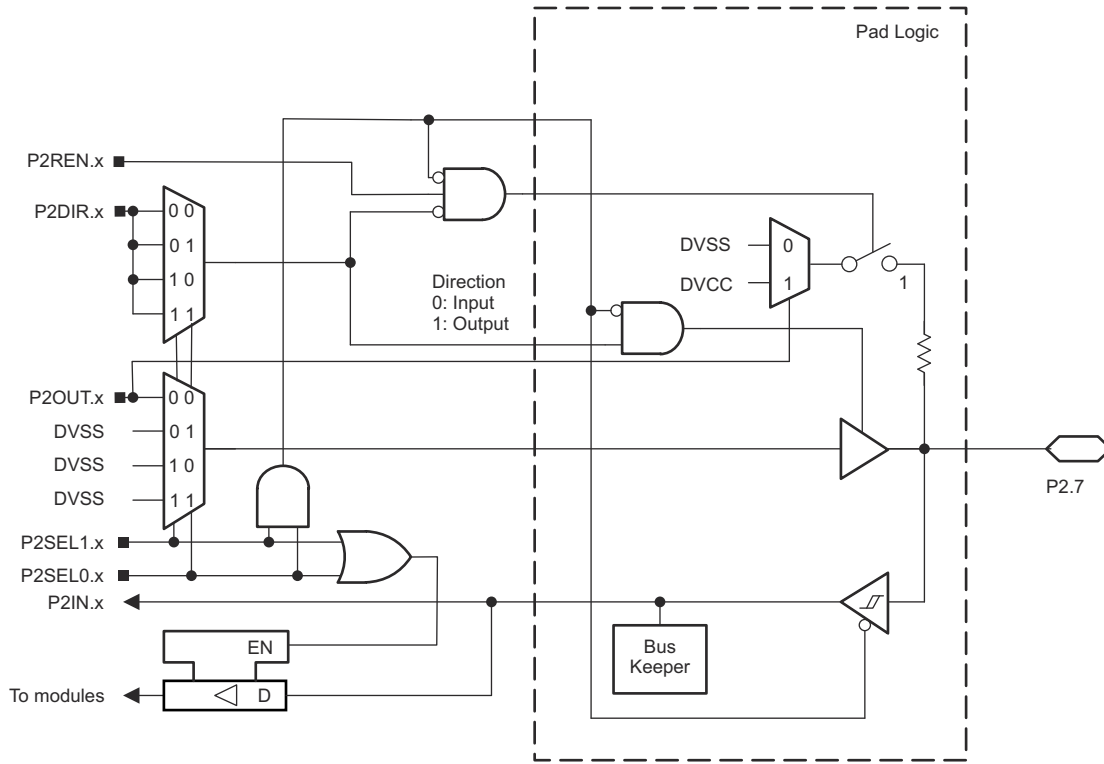

Functional representation only.

Figure 9-9. Port P2 (P2.7) Diagram

Table 9-26. Port P2 (P2.7) Pin Functions

PIN NAME (P2.x)	x	FUNCTION	CONTROL BITS AND SIGNALS ⁽¹⁾		
			P2DIR.x	P2SEL1.x	P2SEL0.x
P2.7	7	P2.7(I/O)	0 = Input, 1 = Output	0	0
		N/A	0	0	1
		Internally tied to DVSS	1		
		N/A	0	1	X
		Internally tied to DVSS	1		

(1) X = Don't care

9.13.9 Port P3 (P3.0 to P3.3) Input/Output With Schmitt Trigger

Figure 9-10 shows the port diagram. Table 9-27 summarizes the selection of the pin functions.

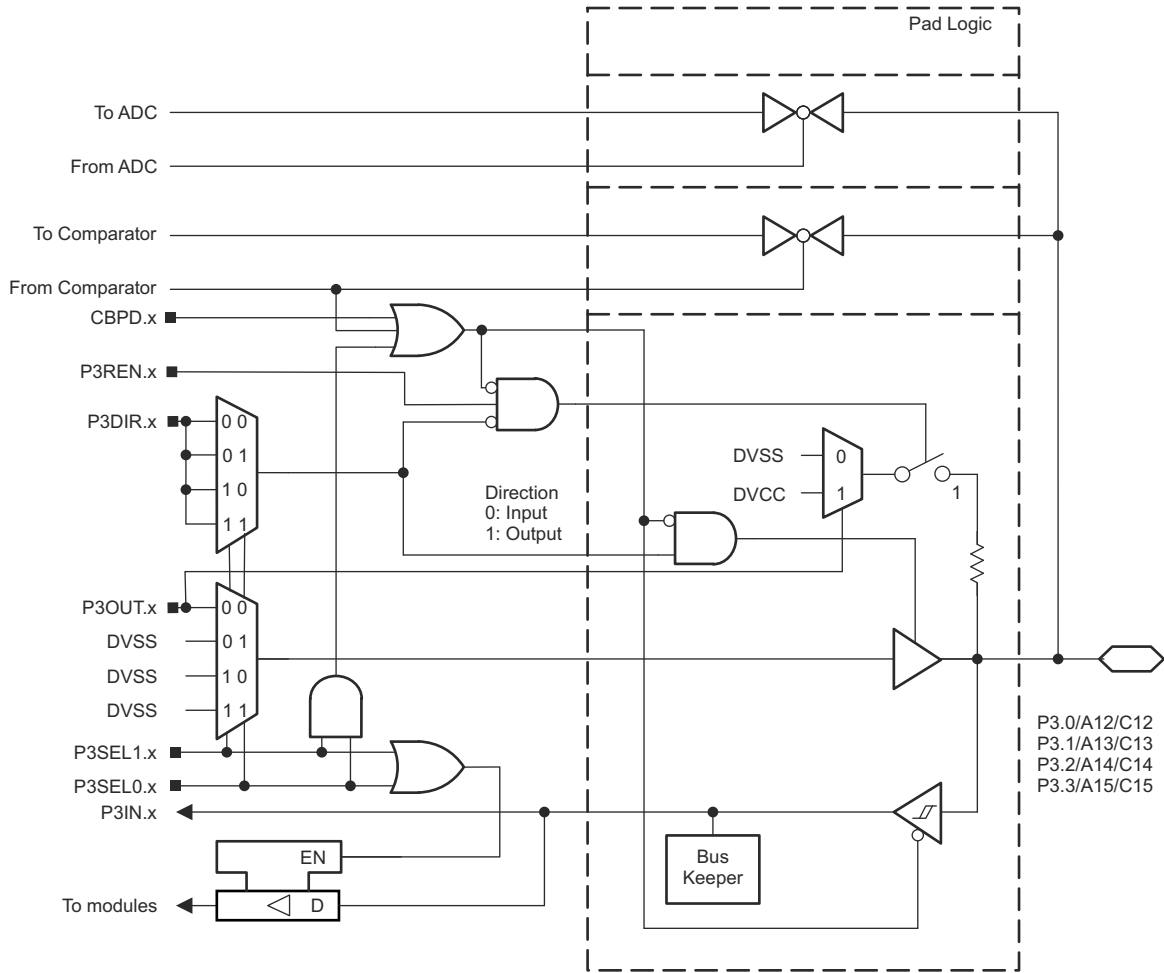

Functional representation only.

Figure 9-10. Port P3 (P3.0 to P3.3) Diagram

Table 9-27. Port P3 (P3.0 to P3.3) Pin Functions

PIN NAME (P3.x)	x	FUNCTION	CONTROL BITS AND SIGNALS ⁽¹⁾		
			P3DIR.x	P3SEL1.x	P3SEL0.x
P3.0/A12/C12	0	P3.0 (I/O)	0 = Input, 1 = Output	0	0
		N/A	0	0	1
		Internally tied to DVSS	1		
		N/A	0	1	0
		Internally tied to DVSS	1		
		A12/C12 ^{(2) (3)}	X	1	1
P3.1/A13/C13	1	P3.1 (I/O)	0 = Input, 1 = Output	0	0
		N/A	0	0	1
		Internally tied to DVSS	1		
		N/A	0	1	0
		Internally tied to DVSS	1		
		A13/C13 ^{(2) (3)}	X	1	1
P3.2/A14/C14	2	P3.2 (I/O)	0 = Input, 1 = Output	0	0
		N/A	0	0	1
		Internally tied to DVSS	1		
		N/A	0	1	0
		Internally tied to DVSS	1		
		A14/C14 ^{(2) (3)}	X	1	1
P3.3/A15/C15	3	P3.3 (I/O)	0 = Input, 1 = Output	0	0
		N/A	0	0	1
		Internally tied to DVSS	1		
		N/A	0	1	0
		Internally tied to DVSS	1		
		A15/C15 ^{(2) (3)}	X	1	1

(1) X = Don't care

(2) Setting P3SEL1.x and P3SEL0.x disables the output driver and the input Schmitt trigger to prevent parasitic cross currents when applying analog signals.

(3) Setting the CEPDx bit of the comparator disables the output driver and the input Schmitt trigger to prevent parasitic cross currents when applying analog signals. Selecting the Cx input pin to the comparator multiplexer with the input select bits in the comparator module automatically disables output driver and input buffer for that pin, regardless of the state of the associated CEPDx bit.

9.13.10 Port P3 (P3.4 to P3.7) Input/Output With Schmitt Trigger

Figure 9-11 shows the port diagram. Table 9-28 summarizes the selection of the pin functions.

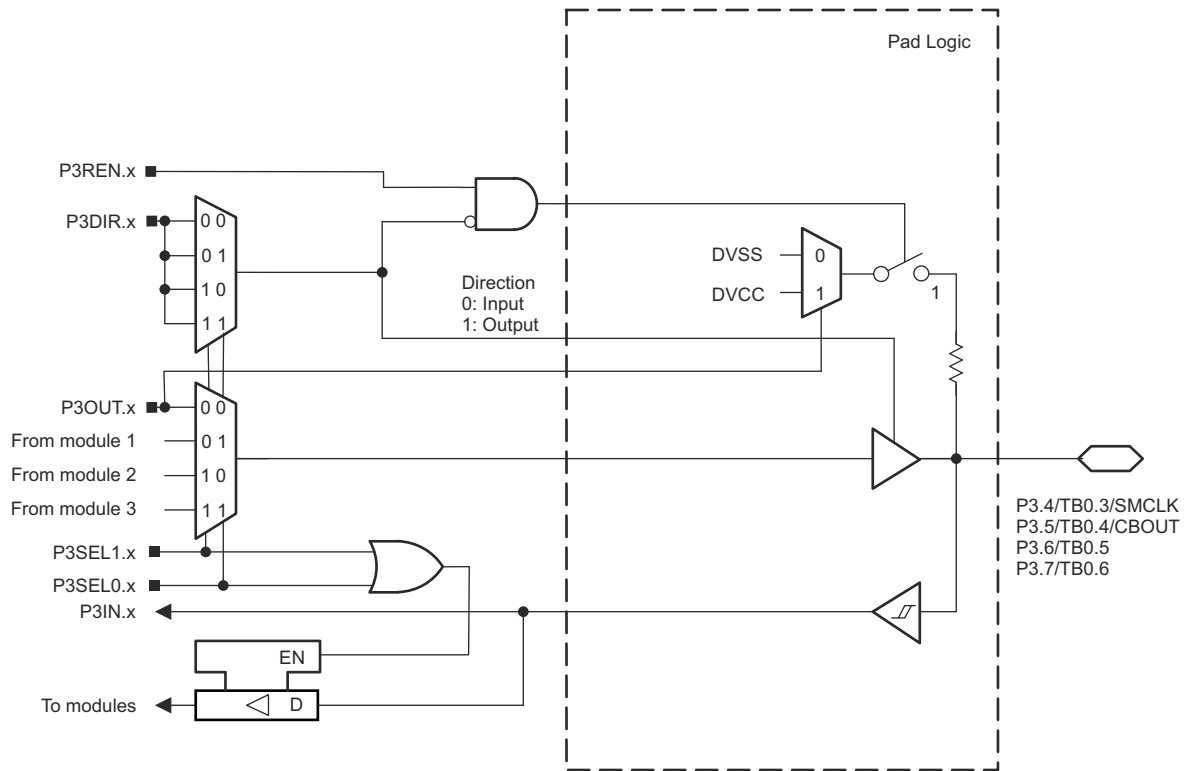

Functional representation only.

Figure 9-11. Port P3 (P3.4 to P3.7) Diagram

Table 9-28. Port P3 (P3.4 to P3.7) Pin Functions

PIN NAME (P3.x)	x	FUNCTION	CONTROL BITS AND SIGNALS ⁽¹⁾		
			P3DIR.x	P3SEL1.x	P3SEL0.x
P3.4/TB0.3/SMCLK	4	P3.4 (I/O)	0 = Input, 1 = Output	0	0
		TB0.CCI3A	0	0	1
		TB0.3	1		
		N/A	0	1	X
		SMCLK	1		
P3.5/TB0.4/COU2	5	P3.5 (I/O)	0 = Input, 1 = Output	0	0
		TB0.CCI4A	0	0	1
		TB0.4	1		
		N/A	0	1	X
		COU2	1		
P3.6/TB0.5	6	P3.6 (I/O)	0 = Input, 1 = Output	0	0
		TB0.CCI5A	0	0	1
		TB0.5	1		
		N/A	0	1	X
		Internally tied to DVSS	1		
P3.7/TB0.6	7	P3.7 (I/O)	0 = Input, 1 = Output	0	0
		TB0.CCI6A	0	0	1
		TB0.6	1		
		N/A	0	1	X
		Internally tied to DVSS	1		

(1) X = Don't care

9.13.11 Port P4 (P4.0 to P4.3) Input/Output With Schmitt Trigger

Figure 9-12 shows the port diagram. Table 9-29 summarizes the selection of the pin functions.

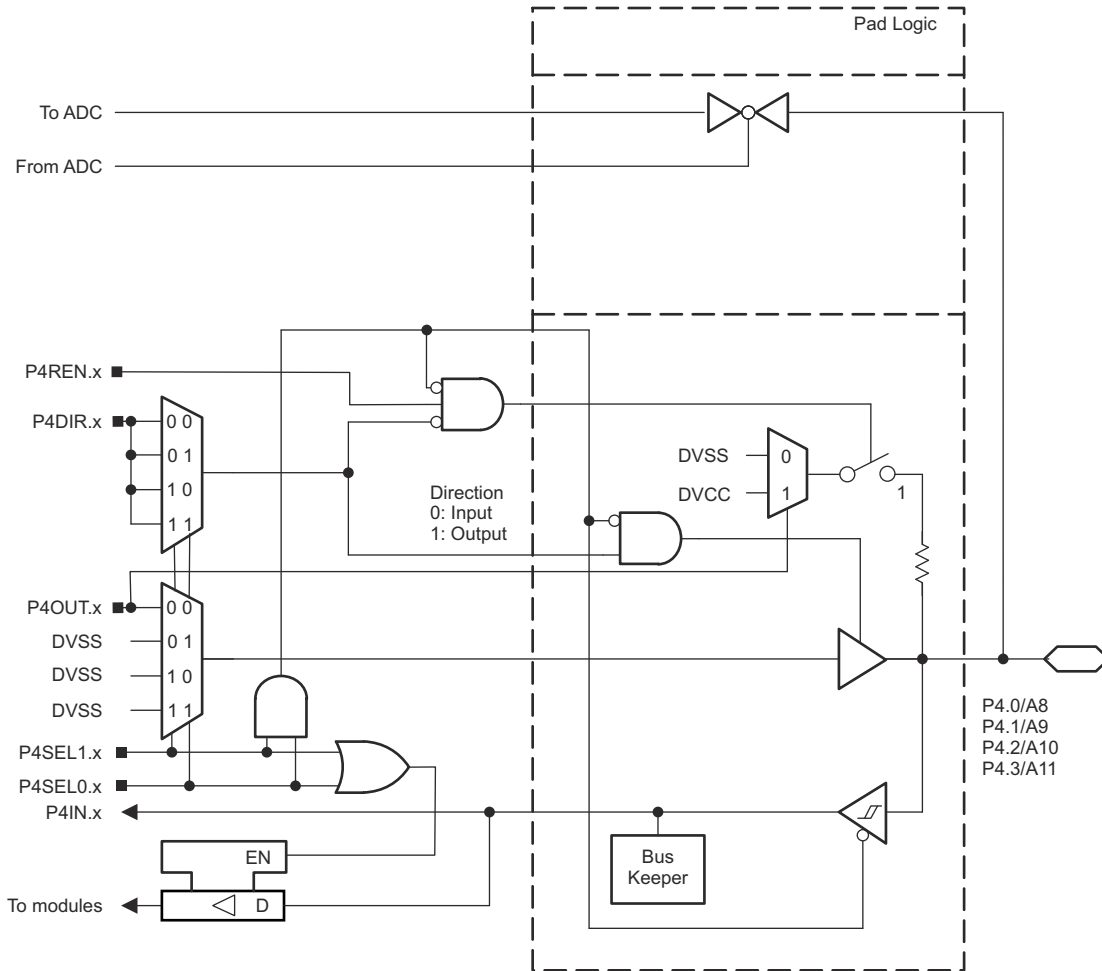

Functional representation only.

Figure 9-12. Port P4 (P4.0 to P4.3) Diagram

Table 9-29. Port P4 (P4.0 to P4.3) Pin Functions

PIN NAME (P4.x)	x	FUNCTION	CONTROL BITS AND SIGNALS ⁽¹⁾		
			P4DIR.x	P4SEL1.x	P4SEL0.x
P4.0/A8	0	P4.0 (I/O)	0 = Input, 1 = Output	0	0
		N/A	0	0	1
		Internally tied to DVSS	1		
		N/A	0	1	0
		Internally tied to DVSS	1		
		A8 ⁽²⁾	X	1	1
P4.1/A9	1	P4.1 (I/O)	0 = Input, 1 = Output	0	0
		N/A	0	0	1
		Internally tied to DVSS	1		
		N/A	0	1	0
		Internally tied to DVSS	1		
		A9 ⁽²⁾	X	1	1
P4.2/A10	2	P4.2 (I/O)	0 = Input, 1 = Output	0	0
		N/A	0	0	1
		Internally tied to DVSS	1		
		N/A	0	1	0
		Internally tied to DVSS	1		
		A10 ⁽²⁾	X	1	1
P4.3/A11	3	P4.3 (I/O)	0 = Input, 1 = Output	0	0
		N/A	0	0	1
		Internally tied to DVSS	1		
		N/A	0	1	0
		Internally tied to DVSS	1		
		A11 ⁽²⁾	X	1	1

(1) X = Don't care

(2) Setting P4SEL1.x and P4SEL0.x disables the output driver and the input Schmitt trigger to prevent parasitic cross currents when applying analog signals.

9.13.12 Port P4 (P4.4 to P4.7) Input/Output With Schmitt Trigger

Figure 9-13 shows the port diagram. Table 9-30 summarizes the selection of the pin functions.

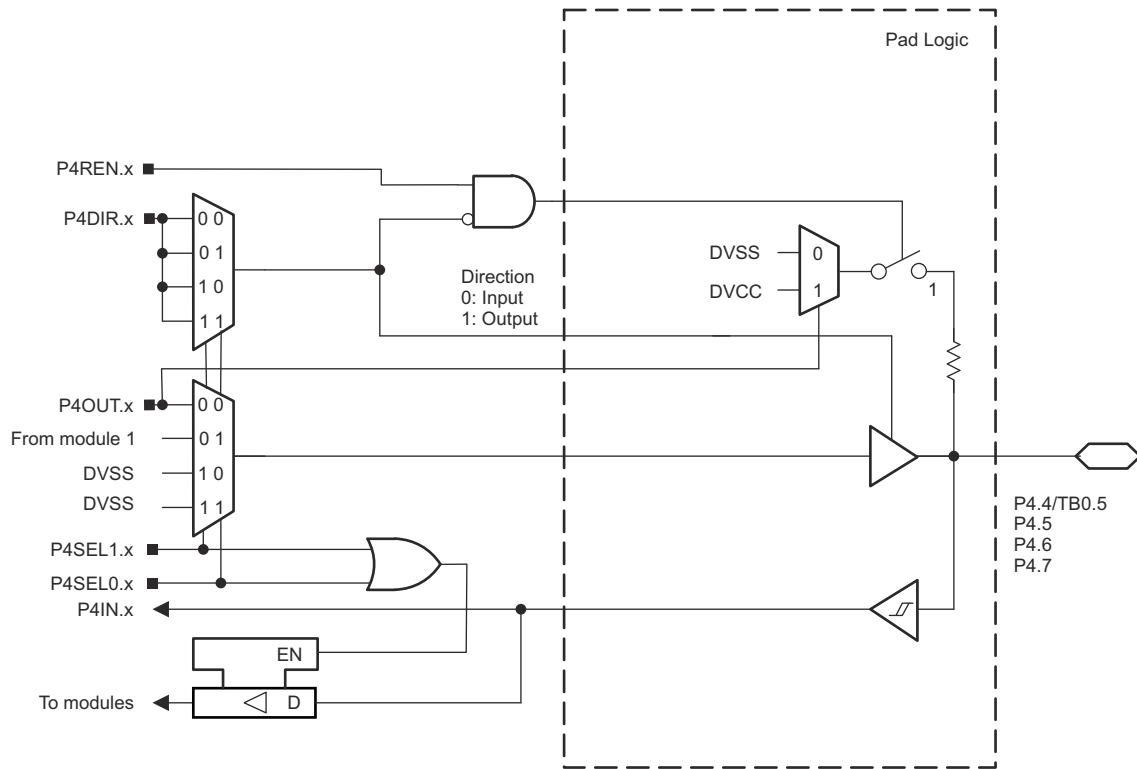

Functional representation only.

Figure 9-13. Port P4 (P4.4 to P4.7) Diagram

Table 9-30. Port P4 (P4.4 to P4.7) Pin Functions

PIN NAME (P4.x)	x	FUNCTION	CONTROL BITS AND SIGNALS ⁽¹⁾		
			P4DIR.x	P4SEL1.x	P4SEL0.x
P4.4/TB0.5	4	P4.4 (I/O)	0 = Input, 1 = Output	0	0
		TB0.CCI5B	0	0	1
		TB0.5	1		
		N/A	0	1	X
		Internally tied to DVSS	1		
P4.5	5	P4.5 (I/O)	0 = Input, 1 = Output	0	0
		N/A	0	0	1
		Internally tied to DVSS	1		
		N/A	0	1	X
		Internally tied to DVSS	1		
P4.6	6	P4.6 (I/O)	0 = Input, 1 = Output	0	0
		N/A	0	0	1
		Internally tied to DVSS	1		
		N/A	0	1	X
		Internally tied to DVSS	1		
P4.7	7	P4.7 (I/O)	0 = Input, 1 = Output	0	0
		N/A	0	0	1
		Internally tied to DVSS	1		
		N/A	0	1	X
		Internally tied to DVSS	1		

(1) X = Don't care

9.13.13 Port P5 (P5.0 to P5.7) Input/Output With Schmitt Trigger

Figure 9-14 shows the port diagram. Table 9-31 summarizes the selection of the pin functions.

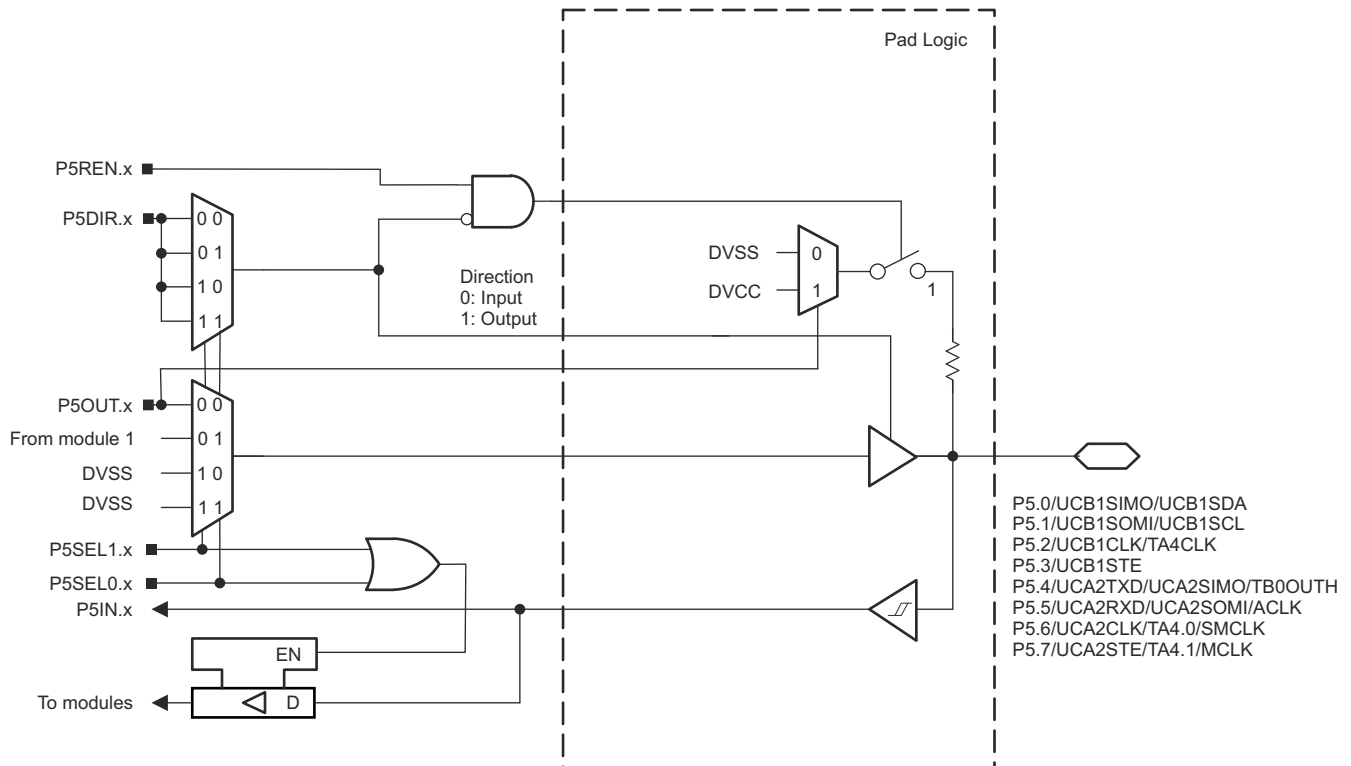

Functional representation only.

Figure 9-14. Port P5 (P5.0 to P5.7) Diagram

Table 9-31. Port P5 (P5.0 to P5.7) Pin Functions

PIN NAME (P5.x)	x	FUNCTION	CONTROL BITS AND SIGNALS ⁽¹⁾		
			P5DIR.x	P5SEL1.x	P5SEL0.x
P5.0/UCB1SIMO/UCB1SDA	0	P5.0 (I/O)	0 = Input, 1 = Output	0	0
		UCB1SIMO/UCB1SDA	X ⁽²⁾	0	1
		N/A	0	1	X
		Internally tied to DVSS	1		
P5.1/UCB1SOMI/UCB1SCL	1	P5.1 (I/O)	0 = Input, 1 = Output	0	0
		UCB1SOMI/UCB1SCL	X ⁽²⁾	0	1
		N/A	0	1	X
		Internally tied to DVSS	1		
P5.2/UCB1CLK/TA4CLK	2	P5.2 (I/O)	0 = Input, 1 = Output	0	0
		UCB1CLK	X ⁽²⁾	0	1
		TA4CLK	0	1	0
		Internally tied to DVSS	1		
		N/A	0	1	1
		Internally tied to DVSS	1		

Table 9-31. Port P5 (P5.0 to P5.7) Pin Functions (continued)

PIN NAME (P5.x)	x	FUNCTION	CONTROL BITS AND SIGNALS ⁽¹⁾		
			P5DIR.x	P5SEL1.x	P5SEL0.x
P5.3/UCB1STE	3	P5.3 (I/O)	0 = Input, 1 = Output	0	0
		UCB1STE	X ⁽²⁾	0	1
		N/A	0	1	1
		Internally tied to DVSS	1		
P5.4/UCA2TXD/UCA2SIMO/ TB0OUTH	4	P5.4 (I/O)	0 = Input, 1 = Output	0	0
		UCA2TXD/UCA2SIMO	X ⁽³⁾	0	1
		N/A	0	1	0
		Internally tied to DVSS	1		
		TB0OUTH	0	1	1
		Internally tied to DVSS	1		
P5.5/UCA2RXD/UCA2SOMI/ ACLK	5	P5.5 (I/O)	0 = Input, 1 = Output	0	0
		UCA2RXD/UCA2SOMI	X ⁽³⁾	0	1
		N/A	0	1	0
		Internally tied to DVSS	1		
		N/A	0	1	1
		ACLK	1		
P5.6/UCA2CLK/TA4.0/SMCLK	6	P5.6 (I/O)	0 = Input, 1 = Output	0	0
		UCA2CLK	X ⁽³⁾	0	1
		TA4.CCI0A	0	1	0
		TA4.0	1		
		N/A	0	1	1
		SMCLK	1		
P5.7/UCA2STE/TA4.1/MCLK	7	P5.7 (I/O)	0 = Input, 1 = Output	0	0
		UCA2STE	X ⁽³⁾	0	1
		TA4.CCI1A	0	1	0
		TA4.1	1		
		NA	0	1	1
		MCLK	1		

(1) X = Don't care

(2) Direction controlled by eUSCI_B1 module.

(3) Direction controlled by eUSCI_A2 module.

9.13.14 Port P6 (P6.0 to P6.7) Input/Output With Schmitt Trigger

Figure 9-15 shows the port diagram. Table 9-32 summarizes the selection of the pin functions.

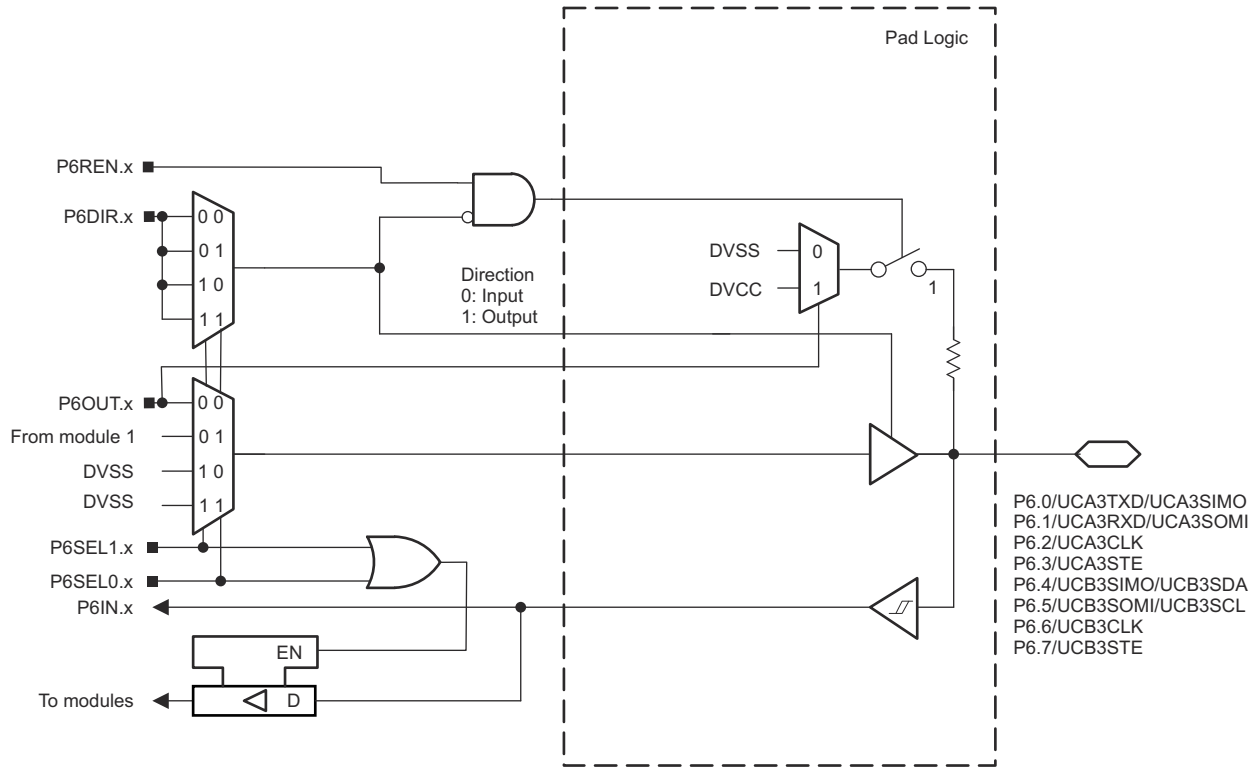

Functional representation only.

Figure 9-15. Port P6 (P6.0 to P6.7) Diagram

Table 9-32. Port P6 (P6.0 to P6.7) Pin Functions

PIN NAME (P6.x)	x	FUNCTION	CONTROL BITS AND SIGNALS ⁽¹⁾		
			P6DIR.x	P6SEL1.x	P6SEL0.x
P6.0/UCA3TXD/UCA3SIMO	0	P6.0 (I/O)	0 = Input, 1 = Output	0	0
		UCA3TXD/UCA3SIMO	X ⁽³⁾	0	1
		N/A	0	1	X
		Internally tied to DVSS	1		
P6.1/UCA3RXD/UCA3SOMI	1	P6.1 (I/O)	0 = Input, 1 = Output	0	0
		UCA3RXD/UCA3SOMI	X ⁽³⁾	0	1
		N/A	0	1	X
		Internally tied to DVSS	1		
P6.2/UCA3CLK	2	P6.2 (I/O)	0 = Input, 1 = Output	0	0
		UCA3CLK	X ⁽³⁾	0	1
		N/A	0	1	X
		Internally tied to DVSS	1		
P6.3/UCA3STE	3	P6.3 (I/O)	0 = Input, 1 = Output	0	0
		UCA3STE	X ⁽³⁾	0	1
		N/A	0	1	X
		Internally tied to DVSS	1		
P6.4/UCB3SIMO/UCB3SDA	4	P6.4 (I/O)	0 = Input, 1 = Output	0	0
		UCB3SIMO/UCB3SDA	X ⁽²⁾	0	1
		N/A	0	1	X
		Internally tied to DVSS	1		
P6.5/UCB3SOMI/UCB3SCL	5	P6.5 (I/O)	0 = Input, 1 = Output	0	0
		UCB3SOMI/UCB3SCL	X ⁽²⁾	0	1
		N/A	0	1	X
		Internally tied to DVSS	1		
P6.6/UCB3CLK	6	P6.6 (I/O)	0 = Input, 1 = Output	0	0
		UCB3CLK	X ⁽²⁾	0	1
		N/A	0	1	X
		Internally tied to DVSS	1		
P6.7/UCB3STE	7	P6.7 (I/O)	0 = Input, 1 = Output	0	0
		UCB3STE	X ⁽²⁾	0	1
		N/A	0	1	X
		Internally tied to DVSS	1		

(1) X = Don't care

(2) Direction controlled by eUSCI_B3 module.

(3) Direction controlled by eUSCI_A3 module.

9.13.15 Port P7 (P7.0 to P7.3) Input/Output With Schmitt Trigger

Figure 9-16 shows the port diagram. Table 9-33 summarizes the selection of the pin functions.

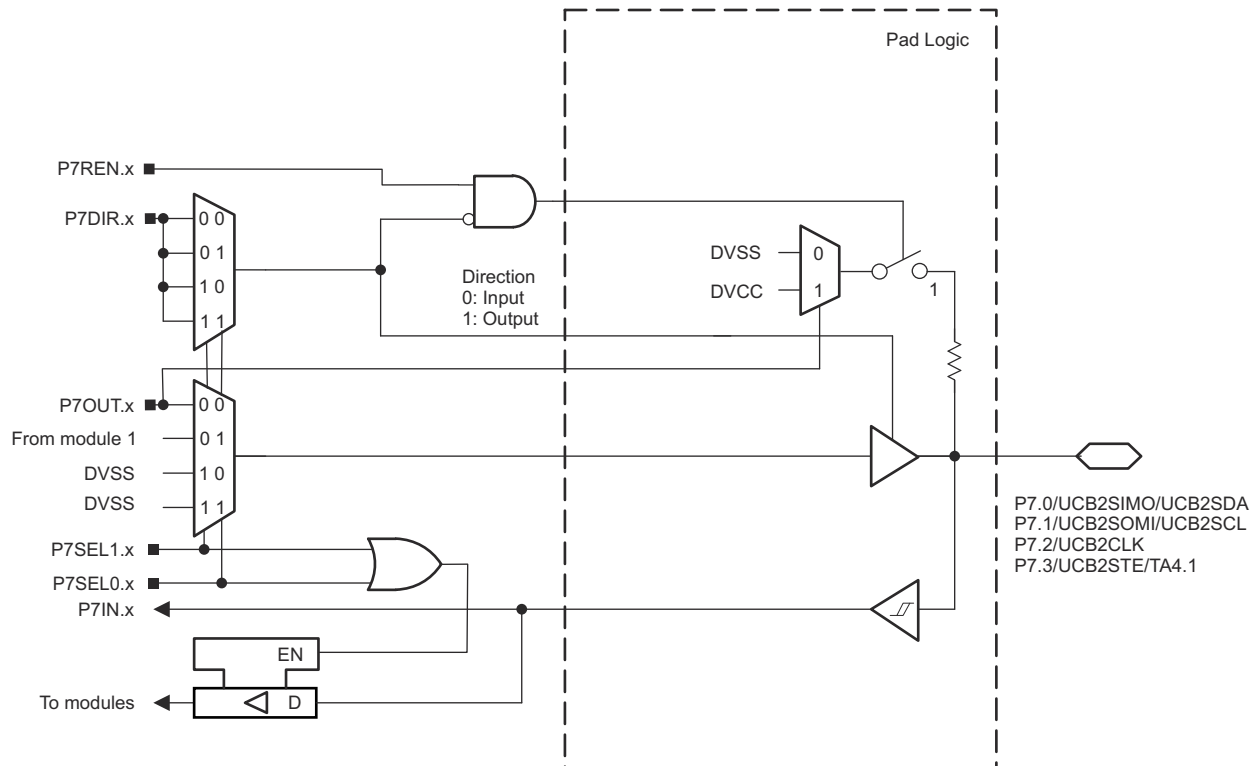

Functional representation only.

Figure 9-16. Port P7 (P7.0 to P7.3) Diagram

Table 9-33. Port P7 (P7.0 to P7.3) Pin Functions

PIN NAME (P7.x)	x	FUNCTION	CONTROL BITS AND SIGNALS ⁽¹⁾		
			P7DIR.x	P7SEL1.x	P7SEL0.x
P7.0/UCB2SIMO/UCB2SDA	0	P7.0 (I/O)	0 = Input, 1 = Output	0	0
		UCB2SIMO/UCB2SDA	X ⁽²⁾	0	1
		N/A	0	1	X
		Internally tied to DVSS	1		
P7.1/UCB2SOMI/UCB2SCL	1	P7.1 (I/O)	0 = Input, 1 = Output	0	0
		UCB2SOMI/UCB2SCL	X ⁽²⁾	0	1
		N/A	0	1	X
		Internally tied to DVSS	1		
P7.2/UCB2CLK	2	P7.2 (I/O)	0 = Input, 1 = Output	0	0
		UCB2CLK	X ⁽²⁾	0	1
		N/A	0	1	X
		Internally tied to DVSS	1		
P7.3/UCB2STE/TA4.1	3	P7.3 (I/O)	0 = Input, 1 = Output	0	0
		UCB2STE	X ⁽²⁾	0	1
		TA4.CC1B	0	1	0
		TA4.1	1		
		N/A	0	1	1
		Internally tied to DVSS	1		

(1) X = Don't care

(2) Direction controlled by eUSCI_B2 module.

9.13.16 Port P7 (P7.4 to P7.7) Input/Output With Schmitt Trigger

Figure 9-17 shows the port diagram. Table 9-34 summarizes the selection of the pin functions.

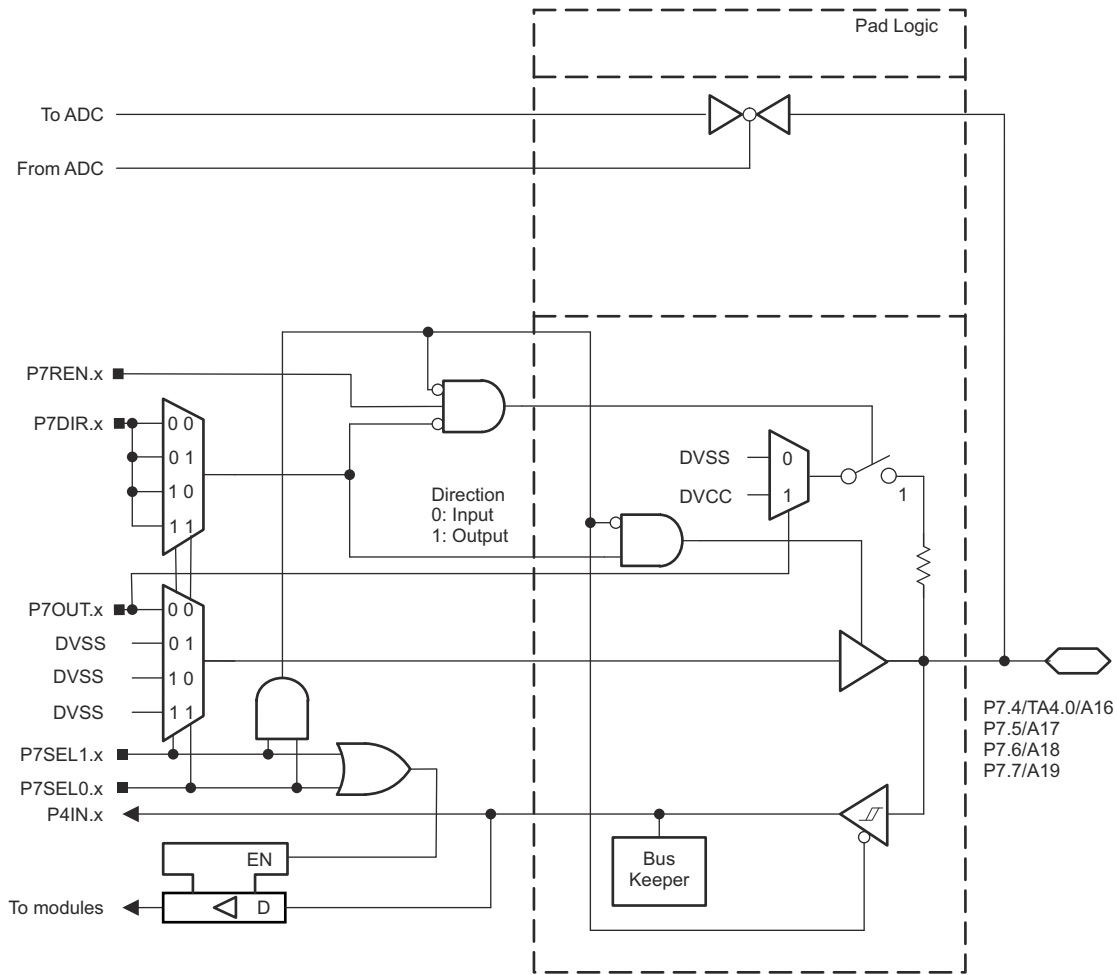

Functional representation only.

Figure 9-17. Port P7 (P7.3 to P7.7) Diagram

Table 9-34. Port P7 (P7.3 to P7.7) Pin Functions

PIN NAME (P7.x)	x	FUNCTION	CONTROL BITS AND SIGNALS ⁽¹⁾		
			P7DIR.x	P7SEL1.x	P7SEL0.x
P7.4/TA4.0/A16	4	P7.4 (I/O)	0 = Input, 1 = Output	0	0
		N/A	0	0	1
		Internally tied to DVSS	1		
		TA4.CCI0B	0	1	0
		TA4.0	1		
		A16 ⁽²⁾	X	1	1
P7.5/A17	5	P7.5 (I/O)	0 = Input, 1 = Output	0	0
		N/A	0	0	1
		Internally tied to DVSS	1		
		N/A	0	1	0
		Internally tied to DVSS	1		
		A17 ⁽²⁾	X	1	1
P7.6/A18	6	P7.6 (I/O)	0 = Input, 1 = Output	0	0
		N/A	0	0	1
		Internally tied to DVSS	1		
		N/A	0	1	0
		Internally tied to DVSS	1		
		A18 ⁽²⁾	X	1	1
P7.7/A19	7	P7.7 (I/O)	0 = Input, 1 = Output	0	0
		N/A	0	0	1
		Internally tied to DVSS	1		
		N/A	0	1	0
		Internally tied to DVSS	1		
		A19 ⁽²⁾	X	1	1

(1) X = Don't care

(2) Setting P7SEL1.x and P7SEL0.x disables the output driver and the input Schmitt trigger to prevent parasitic cross currents when applying analog signals.

9.13.17 Port P8 (P8.0 to P8.3) Input/Output With Schmitt Trigger

Figure 9-18 shows the port diagram. Table 9-35 summarizes the selection of the pin functions.

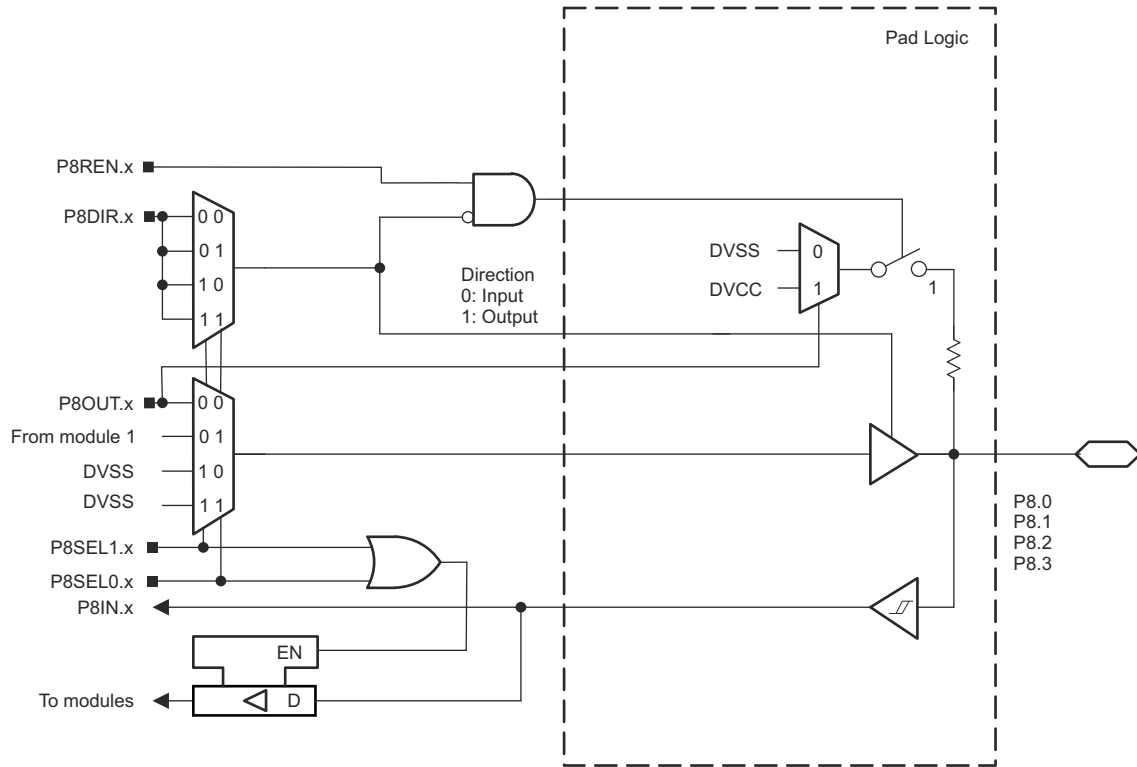

Functional representation only.

Figure 9-18. Port P8 (P8.0 to P8.3) Diagram

Table 9-35. Port P8 (P8.0 to P8.3) Pin Functions

PIN NAME (P8.x)	x	FUNCTION	CONTROL BITS AND SIGNALS ⁽¹⁾		
			P8DIR.x	P8SEL1.x	P8SEL0.x
P8.0	0	P8.0(I/O)	0 = Input, 1 = Output	0	0
		N/A	0	0	1
		Internally tied to DVSS	1		
		N/A	0	1	X
		Internally tied to DVSS	1		
P8.1	1	P8.1 (I/O)	0 = Input, 1 = Output	0	0
		N/A	0	0	1
		Internally tied to DVSS	1		
		N/A	0	1	X
		Internally tied to DVSS	1		
P8.2	2	P8.2 (I/O)	0 = Input, 1 = Output	0	0
		N/A	0	0	1
		Internally tied to DVSS	1		
		N/A	0	1	X
		Internally tied to DVSS	1		
P8.3	3	P8.3 (I/O)	0 = Input, 1 = Output	0	0
		N/A	0	0	1
		Internally tied to DVSS	1		
		N/A	0	1	X
		Internally tied to DVSS	1		

(1) X = Don't care

9.13.18 Port PJ (PJ.4 and PJ.5) Input/Output With Schmitt Trigger

Figure 9-19 and Figure 9-20 show the port diagrams. Table 9-36 summarizes the selection of the pin functions.

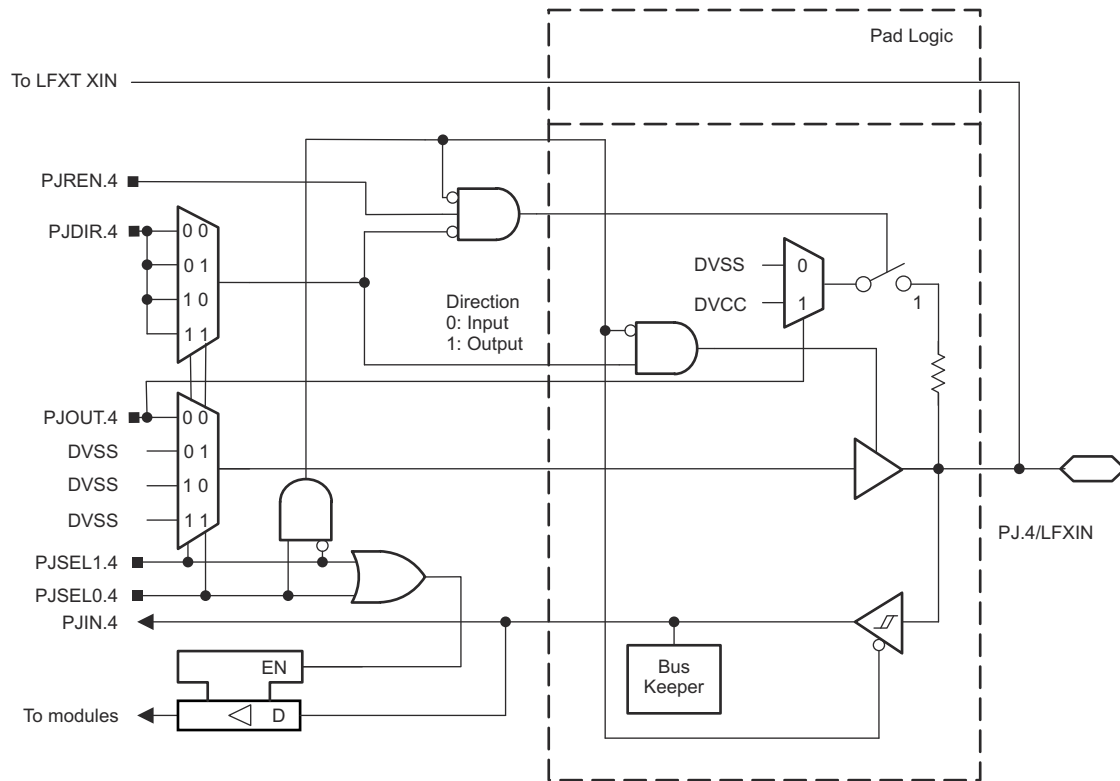

Functional representation only.

Figure 9-19. Port PJ (PJ.4) Diagram

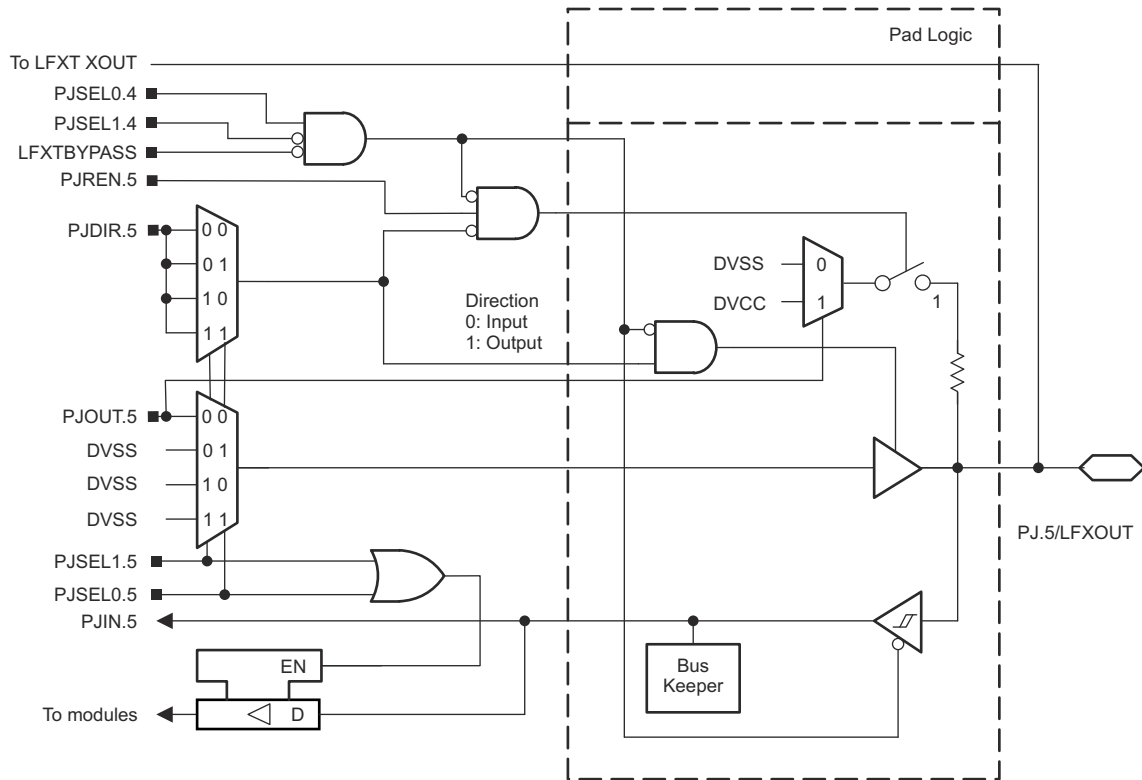

Functional representation only.

Figure 9-20. Port PJ (PJ.5) Diagram

Table 9-36. Port PJ (PJ.4 and PJ.5) Pin Functions

PIN NAME (PJ.x)	x	FUNCTION	CONTROL BITS AND SIGNALS ⁽¹⁾					LFXT BYPASS
			PJDIR.x	PJSEL1.5	PJSEL0.5	PJSEL1.4	PJSEL0.4	
PJ.4/LFXIN	4	PJ.4 (I/O)	0 = Input, 1 = Output	X	X	0	0	X
		N/A	0	X	X	1	X	X
		Internally tied to DVSS	1					
		LFXIN crystal mode ⁽³⁾	X	X	X	0	1	0
		LFXIN bypass mode ⁽³⁾	X	X	X	0	1	1
PJ.5/LFXOUT	5	PJ.5 (I/O)	0 = Input, 1 = Output	0	0	0	0	0
						1	X	
						X	X	
		N/A	0	See ⁽²⁾	See ⁽²⁾	0	0	0
						1	X	
						X	X	
		Internally tied to DVSS	1	See ⁽²⁾	See ⁽²⁾	0	0	0
						1	X	
						X	X	
		LFXOUT crystal mode ⁽³⁾	X	X	X	0	1	0

- (1) X = Don't care
- (2) If PJSEL0.5 = 1 or PJSEL1.5 = 1, the general-purpose I/O functionality is disabled. No input function is available. Configured as output, the pin is actively pulled to zero.
- (3) If PJSEL1.4 = 0 and PJSEL0.4 = 1, the general-purpose I/O is disabled. When LFXTBYPASS = 0, PJ.4 and PJ.5 are configured for crystal operation and PJSEL1.5 and PJSEL0.5 are don't care. When LFXTBYPASS = 1, PJ.4 is configured for bypass operation and PJ.5 is configured as general-purpose I/O.
- (4) When PJ.4 is configured in bypass mode, PJ.5 is configured as general-purpose I/O.

9.13.19 Port PJ (PJ.6 and PJ.7) Input/Output With Schmitt Trigger

Figure 9-21 and Figure 9-22 show the port diagrams. Table 9-37 summarizes the selection of the pin functions.

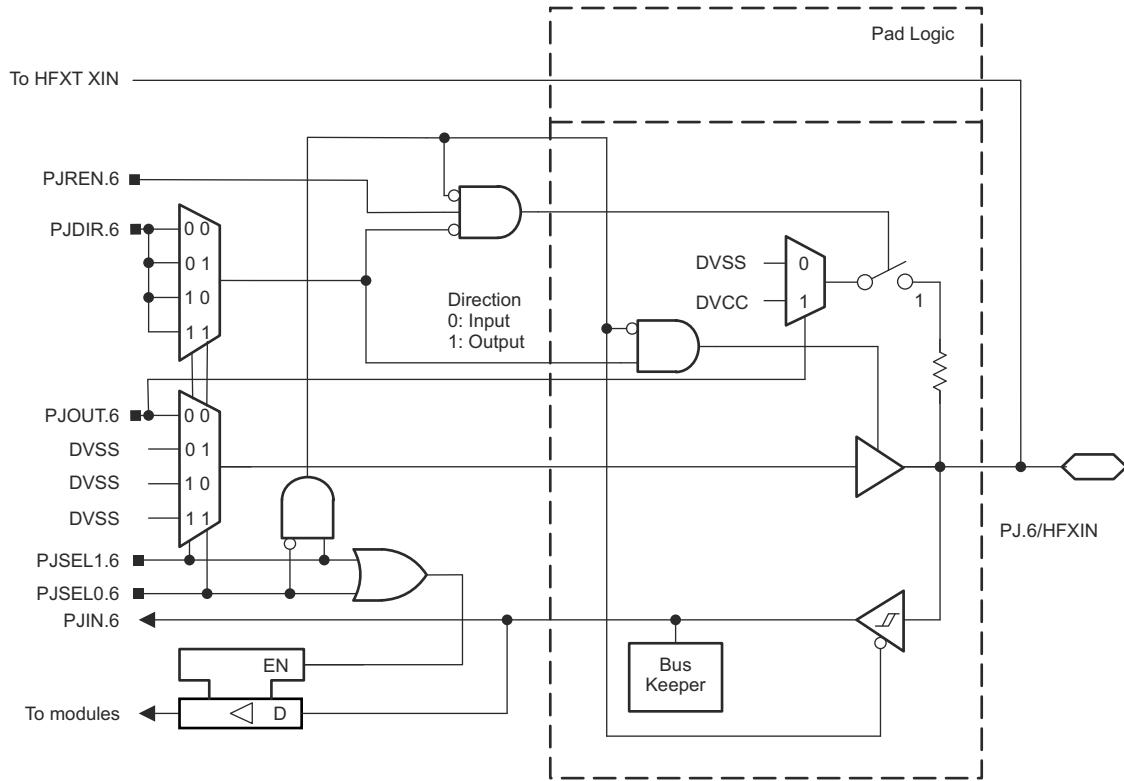

Functional representation only.

Figure 9-21. Port PJ (PJ.6) Diagram

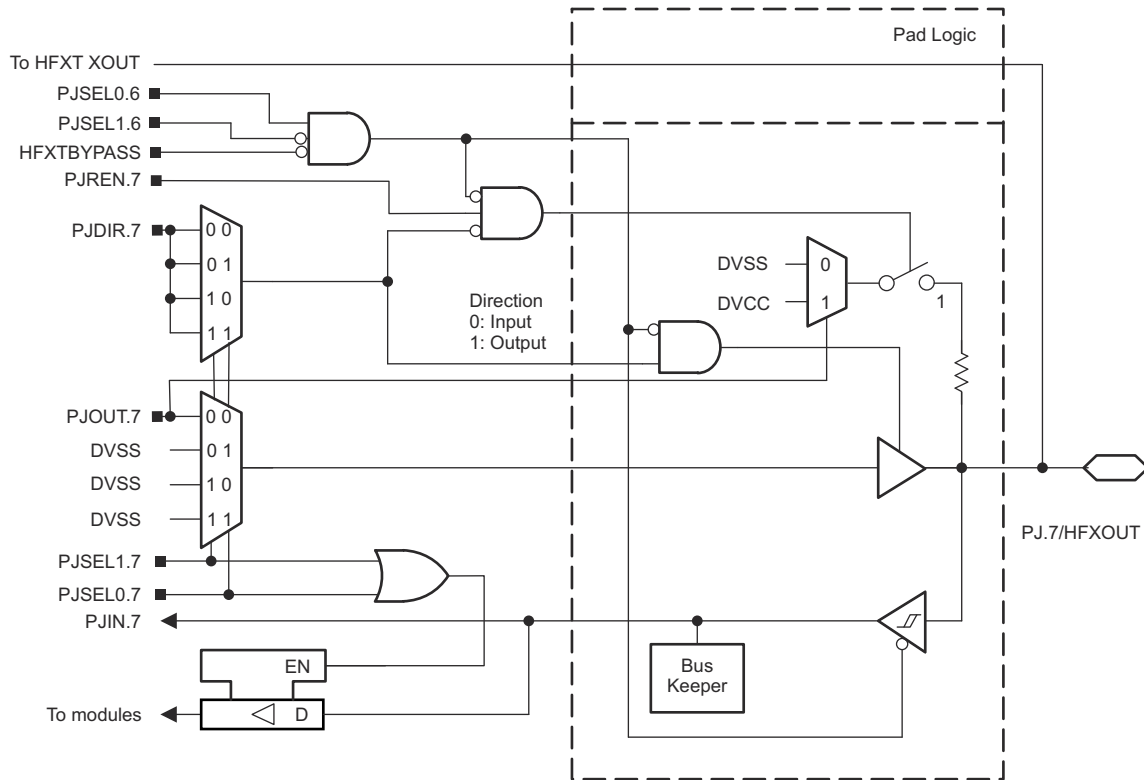

Functional representation only.

Figure 9-22. Port PJ (PJ.7) Diagram

Table 9-37. Port PJ (PJ.6 and PJ.7) Pin Functions

PIN NAME (PJ.x)	x	FUNCTION	CONTROL BITS AND SIGNALS ⁽¹⁾					
			PJDIR.x	PJSEL1.7	PJSEL0.7	PJSEL1.6	PJSEL0.6	HFXTBYPASS
PJ.6/HFXIN	6	PJ.6 (I/O)	0 = Input, 1 = Output	X	X	0	0	X
		N/A	0	X	X	1	X	X
		Internally tied to DVSS	1					
		HFXIN crystal mode ⁽³⁾	X	X	X	0	1	0
		HFXIN bypass mode ⁽³⁾	X	X	X	0	1	1
PJ.7/HFXOUT	7	PJ.7 (I/O) ⁽²⁾	0 = Input, 1 = Output	0	0	0	0	0
						1	X	
						X	X	1 ⁽⁴⁾
		N/A	0	See ⁽²⁾	See ⁽²⁾	0	0	0
						1	X	
						X	X	1 ⁽⁴⁾
		Internally tied to DVSS	1	See ⁽²⁾	See ⁽²⁾	0	0	0
						1	X	
						X	X	1 ⁽⁴⁾
HFXOUT crystal mode ⁽³⁾	X	X	X	0	1	0		

(1) X = Don't care

(2) With PJSEL0.7 = 1 or PJSEL1.7 = 1 the general-purpose I/O functionality is disabled. No input function is available. Configured as output the pin is actively pulled to zero.

(3) Setting PJSEL1.6 = 0 and PJSEL0.6 = 1 causes the general-purpose I/O to be disabled. When HFXTBYPASS = 0, PJ.6 and PJ.7 are configured for crystal operation and PJSEL1.6 and PJSEL0.7 are do not care. When HFXTBYPASS = 1, PJ.6 is configured for bypass operation and PJ.7 is configured as general-purpose I/O.

(4) When PJ.6 is configured in bypass mode, PJ.7 is configured as general-purpose I/O.

9.13.20 Port PJ (PJ.0 to PJ.3) JTAG Pins TDO, TMS, TCK, TDI/TCLK, Input/Output With Schmitt Trigger

Figure 9-23 shows the port diagram. Table 9-38 summarizes the selection of the pin functions.

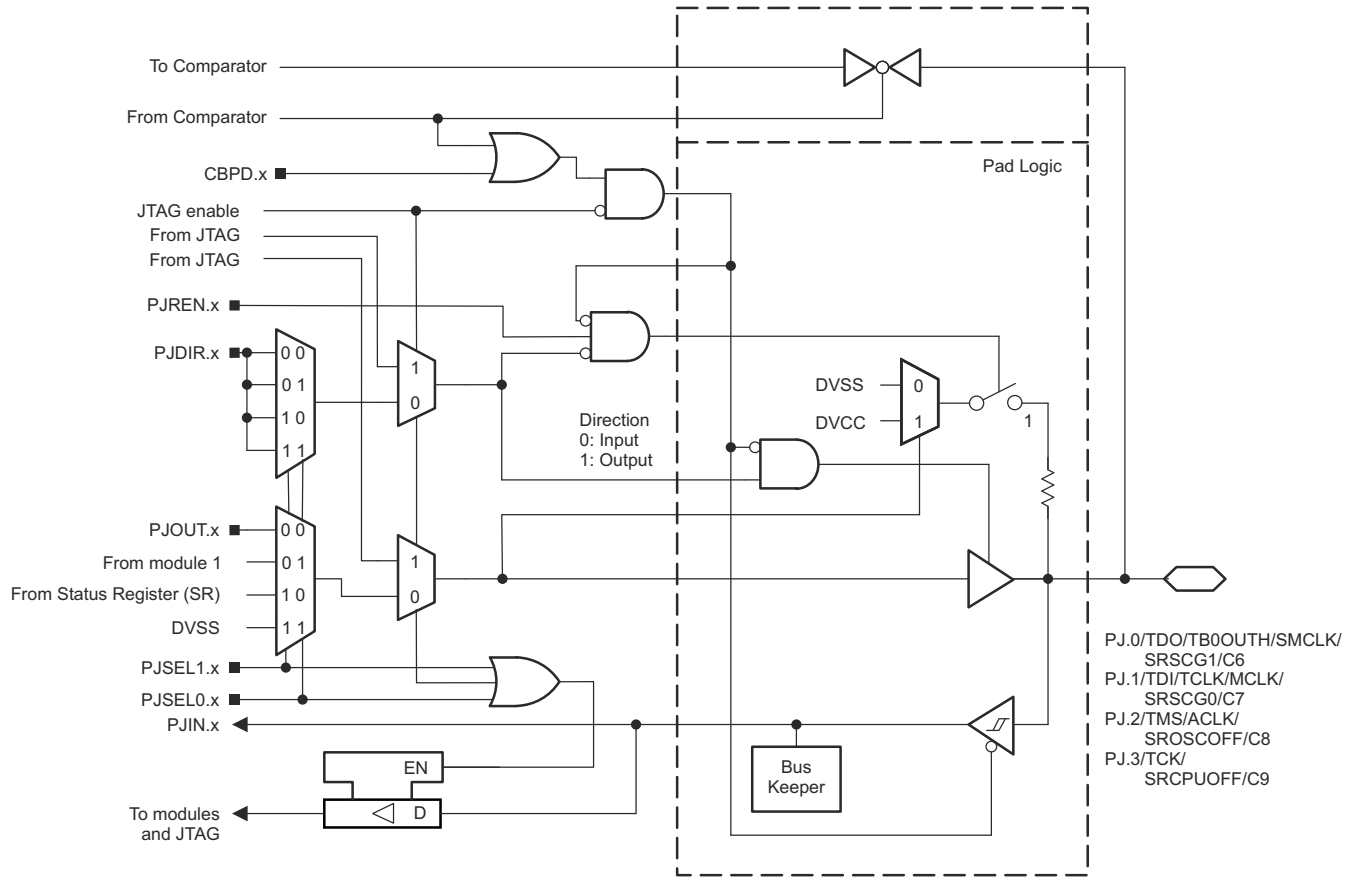

Functional representation only.

Figure 9-23. Port PJ (PJ.0 to PJ.3) Diagram

Table 9-38. Port PJ (PJ.0 to PJ.3) Pin Functions

PIN NAME (PJ.x)	x	FUNCTION	CONTROL BITS OR SIGNALS ⁽¹⁾			
			PJDIR.x	PJSEL1.x	PJSEL0.x	CEPDx (Cx)
PJ.0/TDO/TB0OUTH/ SMCLK/SRSCG1/C6	0	PJ.0 (I/O) ⁽²⁾	0 = Input, 1 = Output	0	0	0
		TDO ⁽³⁾	X	X	X	0
		TB0OUTH	0	0	1	0
		SMCLK ⁽⁶⁾	1			
		N/A	0	1	0	0
		CPU Status Register Bit SCG1	1			
		N/A	0	1	1	0
		Internally tied to DVSS	1			
		C6 ⁽⁵⁾	X	X	X	1

Table 9-38. Port PJ (PJ.0 to PJ.3) Pin Functions (continued)

PIN NAME (PJ.x)	x	FUNCTION	CONTROL BITS OR SIGNALS ⁽¹⁾			
			PJDIR.x	PJSEL1.x	PJSEL0.x	CEPDx (Cx)
PJ.1/TDI/TCLK/MCLK/ SRSCG0/C7	1	PJ.1 (I/O) ⁽²⁾	0 = Input, 1 = Output	0	0	0
		TDI/TCLK ^{(3) (4)}	X	X	X	0
		N/A	0	0	1	0
		MCLK	1			
		N/A	0	1	0	0
		CPU Status Register Bit SCG0	1			
		N/A	0	1	1	0
		Internally tied to DVSS	1			
		C7 ⁽⁵⁾	X	X	X	1
PJ.2/TMS/ACLK/ SROSCOFF/C8	2	PJ.2 (I/O) ⁽²⁾	0 = Input, 1 = Output	0	0	0
		TMS ^{(3) (4)}	X	X	X	0
		N/A	0	0	1	0
		ACLK	1			
		N/A	0	1	0	0
		CPU Status Register Bit OSCOFF	1			
		N/A	0	1	1	0
		Internally tied to DVSS	1			
		C8 ⁽⁵⁾	X	X	X	1
PJ.3/TCK/SRCPUOFF/C9	3	PJ.3 (I/O) ⁽²⁾	0 = Input, 1 = Output	0	0	0
		TCK ^{(3) (4)}	X	X	X	0
		N/A	0	0	1	0
		Internally tied to DVSS	1			
		N/A	0	1	0	0
		CPU Status Register Bit CPUOFF	1			
		N/A	0	1	1	0
		Internally tied to DVSS	1			
		C9 ⁽⁵⁾	X	X	X	1

(1) X = Don't care

(2) Default condition

(3) The pin direction is controlled by the JTAG module. JTAG mode selection is made through the SYS module or by the Spy-Bi-Wire four-wire entry sequence. Neither PJSEL1.x and PJSEL0.x nor CEPDx bits have an effect in these cases.

(4) In JTAG mode, pullups are activated automatically on TMS, TCK, and TDI/TCLK. PJREN.x are don't care.

(5) Setting the CEPDx bit of the comparator disables the output driver and the input Schmitt trigger to prevent parasitic cross currents when applying analog signals. Selecting the Cx input pin to the comparator multiplexer with the input select bits in the comparator module automatically disables the output driver and input buffer for that pin, regardless of the state of the associated CEPDx bit.

(6) Do not use this pin as SMCLK output if the TB0OUTH functionality is used on any other pin. Select an alternate SMCLK output pin.

9.14 Device Descriptors (TLV)

Table 9-40 lists the contents of the device descriptor tag-length-value (TLV) structure for MSP430FR59xx(1) devices including AES. Table 9-39 summarizes the Device IDs of the MSP430FR59xx(1) devices.

Table 9-39. Device IDs

DEVICE	PACKAGE	DEVICE ID	
		01A05h	01A04h
MSP430FR5994	ZVW, PN, PM, and RGZ	0x82	0xA1
MSP430FR59941	ZVW, PN, PM, and RGZ	0x82	0xA2
MSP430FR5992	ZVW, PN, PM, and RGZ	0x82	0xA3
MSP430FR5964	ZVW, PN, PM, and RGZ	0x82	0xA4
MSP430FR5962	ZVW, PN, PM, and RGZ	0x82	0xA6

Table 9-40. Device Descriptor Table

DESCRIPTION ⁽¹⁾		MSP430FR59xx (UART BSL)		MSP430FR59941 (I ² C BSL)	
		ADDRESS	VALUE	ADDRESS	VALUE
Info Block	Info Length	01A00h	06h	01A00h	06h
	CRC Length	01A01h	06h	01A01h	06h
	CRC Value	01A02h	Per unit	01A02h	Per unit
		01A03h	Per unit	01A03h	Per unit
	Device ID	01A04h	See Table 9-39	01A04h	See Table 9-39
		01A05h			
	Hardware Revision	01A06h	Per unit	01A06h	Per unit
Firmware Revision	01A07h	Per unit	01A07h	Per unit	
Die Record	Die Record Tag	01A08h	08h	01A08h	08h
	Die Record length	01A09h	0Ah	01A09h	0Ah
	Lot/Wafer ID	01A0Ah	Per unit	01A0Ah	Per unit
		01A0Bh	Per unit	01A0Bh	Per unit
		01A0Ch	Per unit	01A0Ch	Per unit
		01A0Dh	Per unit	01A0Dh	Per unit
	Die X Position	01A0Eh	Per unit	01A0Eh	Per unit
		01A0Fh	Per unit	01A0Fh	Per unit
	Die Y Position	01A10h	Per unit	01A10h	Per unit
		01A11h	Per unit	01A11h	Per unit
	Test Results	01A12h	Per unit	01A12h	Per unit
01A13h		Per unit	01A13h	Per unit	

Table 9-40. Device Descriptor Table (continued)

DESCRIPTION ⁽¹⁾		MSP430FR59xx (UART BSL)		MSP430FR59941 (I ² C BSL)	
		ADDRESS	VALUE	ADDRESS	VALUE
ADC12 Calibration	ADC12 Calibration Tag	01A14h	11h	01A14h	11h
	ADC12 Calibration Length	01A15h	10h	01A15h	10h
	ADC Gain Factor ⁽²⁾	01A16h	Per unit	01A16h	Per unit
		01A17h	Per unit	01A17h	Per unit
	ADC Offset ⁽³⁾	01A18h	Per unit	01A18h	Per unit
		01A19h	Per unit	01A19h	Per unit
	ADC 1.2-V Reference Temperature Sensor 30°C	01A1Ah	Per unit	01A1Ah	Per unit
		01A1Bh	Per unit	01A1Bh	Per unit
	ADC 1.2-V Reference Temperature Sensor 85°C	01A1Ch	Per unit	01A1Ch	Per unit
		01A1Dh	Per unit	01A1Dh	Per unit
	ADC 2.0-V Reference Temperature Sensor 30°C	01A1Eh	Per unit	01A1Eh	Per unit
		01A1Fh	Per unit	01A1Fh	Per unit
	ADC 2.0-V Reference Temperature Sensor 85°C	01A20h	Per unit	01A20h	Per unit
		01A21h	Per unit	01A21h	Per unit
ADC 2.5-V Reference Temperature Sensor 30°C	01A22h	Per unit	01A22h	Per unit	
	01A23h	Per unit	01A23h	Per unit	
ADC 2.5-V Reference Temperature Sensor 85°C	01A24h	Per unit	01A24h	Per unit	
	01A25h	Per unit	01A25h	Per unit	
REF Calibration	REF Calibration Tag	01A26h	12h	01A26h	12h
	REF Calibration Length	01A27h	06h	01A27h	06h
	REF 1.2-V Reference	01A28h	Per unit	01A28h	Per unit
		01A29h	Per unit	01A29h	Per unit
	REF 2.0-V Reference	01A2Ah	Per unit	01A2Ah	Per unit
		01A2Bh	Per unit	01A2Bh	Per unit
REF 2.5-V Reference	01A2Ch	Per unit	01A2Ch	Per unit	
	01A2Dh	Per unit	01A2Dh	Per unit	
Random Number	128-Bit Random Number Tag	01A2Eh	15h	01A2Eh	15h
	Random Number Length	01A2Fh	10h	01A2Fh	10h
	128-Bit Random Number ⁽⁴⁾	01A30h	Per unit	01A30h	Per unit
		01A31h	Per unit	01A31h	Per unit
		01A32h	Per unit	01A32h	Per unit
		01A33h	Per unit	01A33h	Per unit
		01A34h	Per unit	01A34h	Per unit
		01A35h	Per unit	01A35h	Per unit
		01A36h	Per unit	01A36h	Per unit
		01A37h	Per unit	01A37h	Per unit
		01A38h	Per unit	01A38h	Per unit
		01A39h	Per unit	01A39h	Per unit
		01A3Ah	Per unit	01A3Ah	Per unit
		01A3Bh	Per unit	01A3Bh	Per unit
		01A3Ch	Per unit	01A3Ch	Per unit
		01A3Dh	Per unit	01A3Dh	Per unit
01A3Eh	Per unit	01A3Eh	Per unit		
01A3Fh	Per unit	01A3Fh	Per unit		

Table 9-40. Device Descriptor Table (continued)

DESCRIPTION ⁽¹⁾		MSP430FR59xx (UART BSL)		MSP430FR59941 (I ² C BSL)	
		ADDRESS	VALUE	ADDRESS	VALUE
BSL Configuration	BSL Tag	01A40h	1Ch	01A40h	1Ch
	BSL Length	01A41h	02h	01A41h	02h
	BSL Interface	01A42h	00h	01A42h	01h
	BSL Interface Configuration	01A43h	00h	01A43h	48h

- (1) NA = Not applicable, Per unit = content can differ among individual units
- (2) ADC Gain: the gain correction factor is measured at room temperature using a 2.5-V external voltage reference without internal buffer (ADC12VRSEL = 0x2, 0x4, or 0xE). Other settings (for example, using internal reference) can result in different correction factors.
- (3) ADC Offset: the offset correction factor is measured at room temperature using ADC12VRSEL= 0x2 or 0x4, an external reference, V_{R+} = external 2.5 V, V_{R-} = AVSS.
- (4) 128-Bit Random Number: The random number is generated during production test using Microsoft's CryptGenRandom() function.

9.15 Memory Map

Table 9-41 summarizes the memory map for all device variants.

Table 9-41. Memory Organization

(1)		MSP430FR5994, MSP430FR5964	MSP430FR5992, MSP430FR5962
Memory (FRAM) Main: interrupt vectors and signatures Main: code memory	Total size	256KB 00FFFFh to 00FF80h 043FFFh to 004000h	128KB 00FFFFh to 00FF80h 0023FFFh to 004000h
RAM (shared with LEA on MSP430FR599x)		4KB 003BFFh to 002C00h	4KB 003BFFh to 002C00h
RAM		4KB 002BFFh to 001C00h	4KB 002BFFh to 001C00h
Device descriptor (TLV) (FRAM)		256 bytes 001AFFh to 001A00h	256 bytes 001AFFh to 001A00h
Information memory (FRAM)	Info A	128 bytes 0019FFh to 001980h	128 bytes 0019FFh to 001980h
	Info B	128 bytes 00197Fh to 001900h	128 bytes 00197Fh to 001900h
	Info C	128 bytes 0018FFh to 001880h	128 bytes 0018FFh to 001880h
	Info D	128 bytes 00187Fh to 001800h	128 bytes 00187Fh to 001800h
Bootloader (BSL) memory (ROM)	BSL 3	512 bytes 0017FFh to 001600h	512 bytes 0017FFh to 001600h
	BSL 2	512 bytes 0015FFh to 001400h	512 bytes 0015FFh to 001400h
	BSL 1	512 bytes 0013FFh to 001200h	512 bytes 0013FFh to 001200h
	BSL 0	512 bytes 0011FFh to 001000h	512 bytes 0011FFh to 001000h
Peripherals	Size	4KB 000FFFh to 000020h	4KB 000FFFh to 000020h
Tiny RAM	Size	22 bytes 000001Fh to 00000Ah	22 bytes 000001Fh to 00000Ah
Reserved	Size	10 bytes 000009h to 000000h	10 bytes 000009h to 000000h

(1) All address space not listed is considered vacant memory.

9.15.1 Peripheral File Map

Table 9-42 lists the base address and offset range for the supported module registers. For complete module register descriptions, see the [MSP430FR58xx](#), [MSP430FR59xx](#), and [MSP430FR6xx Family User's Guide](#).

Table 9-42. Peripherals

MODULE NAME	BASE ADDRESS	OFFSET ADDRESS RANGE
Special Functions (see Table 9-43)	0100h	000h to 01Fh
PMM (see Table 9-44)	0120h	000h to 01Fh
FRAM Controller A (see Table 9-45)	0140h	000h to 00Fh
CRC16 (see Table 9-46)	0150h	000h to 007h
RAM Controller (see Table 9-47)	0158h	000h to 00Fh
Watchdog (see Table 9-48)	015Ch	000h to 001h
CS (see Table 9-49)	0160h	000h to 00Fh
SYS (see Table 9-50)	0180h	000h to 01Fh
Shared Reference (see Table 9-51)	01B0h	000h to 001h
Port P1, P2 (see Table 9-52)	0200h	000h to 01Fh
Port P3, P4 (see Table 9-53)	0220h	000h to 01Fh
Port P5, P6 (see Table 9-54)	0240h	000h to 01Fh
Port P7, P8 (see Table 9-55)	0260h	000h to 01Fh
Port PJ (see Table 9-56)	0320h	000h to 01Fh
TA0 (see Table 9-57)	0340h	000h to 02Fh
TA1 (see Table 9-58)	0380h	000h to 02Fh
TB0 (see Table 9-59)	03C0h	000h to 02Fh
TA2 (see Table 9-60)	0400h	000h to 02Fh
Capacitive Touch I/O 0 (see Table 9-61)	0430h	000h to 00Fh
TA3 (see Table 9-62)	0440h	000h to 02Fh
Capacitive Touch I/O 1 (see Table 9-63)	0470h	000h to 00Fh
Real-Time Clock (RTC_C) (see Table 9-64)	04A0h	000h to 01Fh
32-Bit Hardware Multiplier (see Table 9-65)	04C0h	000h to 02Fh
DMA General Control (see Table 9-66)	0500h	000h to 00Fh
DMA Channel 0 (see Table 9-66)	0510h	000h to 00Fh
DMA Channel 1 (see Table 9-66)	0520h	000h to 00Fh
DMA Channel 2 (see Table 9-66)	0530h	000h to 00Fh
DMA Channel 3 (see Table 9-66)	0540h	000h to 00Fh
DMA Channel 4 (see Table 9-66)	0550h	000h to 00Fh
DMA Channel 5 (see Table 9-66)	0560h	000h to 00Fh
MPU Control (see Table 9-67)	05A0h	000h to 00Fh
eUSCI_A0 (see Table 9-68)	05C0h	000h to 01Fh
eUSCI_A1 (see Table 9-69)	05E0h	000h to 01Fh
eUSCI_A2 (see Table 9-70)	0600h	000h to 01Fh
eUSCI_A3 (see Table 9-71)	0620h	000h to 01Fh
eUSCI_B0 (see Table 9-72)	0640h	000h to 02Fh
eUSCI_B1 (see Table 9-73)	0680h	000h to 02Fh
eUSCI_B2 (see Table 9-74)	06C0h	000h to 02Fh
eUSCI_B3 (see Table 9-75)	0700h	000h to 02Fh
TA4 (see Table 9-76)	07C0h	000h to 02Fh
ADC12_B (see Table 9-77)	0800h	000h to 09Fh

Table 9-42. Peripherals (continued)

MODULE NAME	BASE ADDRESS	OFFSET ADDRESS RANGE
Comparator_E (see Table 9-78)	08C0h	000h to 00Fh
CRC32 (see Table 9-79)	0980h	000h to 02Fh
AES (see Table 9-80)	09C0h	000h to 00Fh
LEA ⁽¹⁾ (MSP430FR599x only)	0A80h	000h to 07Fh

- (1) Direct access to LEA registers is not supported, and TI recommends using the optimized [Digital Signal Processing \(DSP\) Library for MSP Microcontrollers](#) for the operations that the LEA module supports.

Table 9-43. Special Function Registers (Base Address: 0100h)

REGISTER DESCRIPTION	ACRONYM	OFFSET
SFR interrupt enable	SFRIE1	00h
SFR interrupt flag	SFRIFG1	02h
SFR reset pin control	SFRRPCR	04h

Table 9-44. PMM Registers (Base Address: 0120h)

REGISTER DESCRIPTION	ACRONYM	OFFSET
PMM control 0	PMMCTL0	00h
PMM interrupt flags	PMMIFG	0Ah
PM5 control 0	PM5CTL0	10h

Table 9-45. FRAM Controller A (FRCTL_A) Control Registers (Base Address: 0140h)

REGISTER DESCRIPTION	ACRONYM	OFFSET
FRAM control 0	FRCTL0	00h
General control 0	GCCTL0	04h
General control 1	GCCTL1	06h

Table 9-46. CRC16 Registers (Base Address: 0150h)

REGISTER DESCRIPTION	ACRONYM	OFFSET
CRC data input	CRC16DI	00h
CRC data input reverse byte	CRCDIRB	02h
CRC initialization and result	CRCINIRES	04h
CRC result reverse byte	CRCRESR	06h

Table 9-47. RAM Controller Registers (Base Address: 0158h)

REGISTER DESCRIPTION	ACRONYM	OFFSET
RAM controller control 0	RCCTL0	00h

Table 9-48. Watchdog Registers (Base Address: 015Ch)

REGISTER DESCRIPTION	ACRONYM	OFFSET
Watchdog timer control	WDTCTL	00h

Table 9-49. CS Registers (Base Address: 0160h)

REGISTER DESCRIPTION	ACRONYM	OFFSET
CS control 0	CSCTL0	00h
CS control 1	CSCTL1	02h
CS control 2	CSCTL2	04h
CS control 3	CSCTL3	06h
CS control 4	CSCTL4	08h
CS control 5	CSCTL5	0Ah
CS control 6	CSCTL6	0Ch

Table 9-50. SYS Registers (Base Address: 0180h)

REGISTER DESCRIPTION	ACRONYM	OFFSET
System control	YSCTL	00h
JTAG mailbox control	SYSJMBC	06h
JTAG mailbox input 0	SYSJMBI0	08h
JTAG mailbox input 1	SYSJMBI1	0Ah
JTAG mailbox output 0	SYSJMBO0	0Ch
JTAG mailbox output 1	SYSJMBO1	0Eh
User NMI vector generator	SYSUNIV	1Ah
System NMI vector generator	SYSSNIV	1Ch
Reset vector generator	SYSRSTIV	1Eh

Table 9-51. Shared Reference Registers (Base Address: 01B0h)

REGISTER DESCRIPTION	ACRONYM	OFFSET
Shared reference control	REFCTL	00h

Table 9-52. Port P1, P2 Registers (Base Address: 0200h)

REGISTER DESCRIPTION	ACRONYM	OFFSET
Port P1 input	P1IN	00h
Port P1 output	P1OUT	02h
Port P1 direction	P1DIR	04h
Port P1 resistor enable	P1REN	06h
Port P1 selection 0	P1SEL0	0Ah
Port P1 selection 1	P1SEL1	0Ch
Port P1 interrupt vector word	P1IV	0Eh
Port P1 complement selection	P1SELC	16h
Port P1 interrupt edge select	P1IES	18h
Port P1 interrupt enable	P1IE	1Ah
Port P1 interrupt flag	P1IFG	1Ch
Port P2 input	P2IN	01h
Port P2 output	P2OUT	03h
Port P2 direction	P2DIR	05h
Port P2 resistor enable	P2REN	07h
Port P2 selection 0	P2SEL0	0Bh
Port P2 selection 1	P2SEL1	0Dh
Port P2 complement selection	P2SELC	17h
Port P2 interrupt vector word	P2IV	1Eh
Port P2 interrupt edge select	P2IES	19h
Port P2 interrupt enable	P2IE	1Bh
Port P2 interrupt flag	P2IFG	1Dh

Table 9-53. Port P3, P4 Registers (Base Address: 0220h)

REGISTER DESCRIPTION	ACRONYM	OFFSET
Port P3 input	P3IN	00h
Port P3 output	P3OUT	02h
Port P3 direction	P3DIR	04h
Port P3 resistor enable	P3REN	06h
Port P3 selection 0	P3SEL0	0Ah
Port P3 selection 1	P3SEL1	0Ch
Port P3 interrupt vector word	P3IV	0Eh
Port P3 complement selection	P3SELC	16h
Port P3 interrupt edge select	P3IES	18h
Port P3 interrupt enable	P3IE	1Ah
Port P3 interrupt flag	P3IFG	1Ch
Port P4 input	P4IN	01h
Port P4 output	P4OUT	03h
Port P4 direction	P4DIR	05h
Port P4 resistor enable	P4REN	07h
Port P4 selection 0	P4SEL0	0Bh
Port P4 selection 1	P4SEL1	0Dh
Port P4 complement selection	P4SELC	17h
Port P4 interrupt vector word	P4IV	1Eh
Port P4 interrupt edge select	P4IES	19h
Port P4 interrupt enable	P4IE	1Bh
Port P4 interrupt flag	P4IFG	1Dh

Table 9-54. Port P5, P6 Registers (Base Address: 0240h)

REGISTER DESCRIPTION	ACRONYM	OFFSET
Port P5 input	P5IN	00h
Port P5 output	P5OUT	02h
Port P5 direction	P5DIR	04h
Port P5 resistor enable	P5REN	06h
Port P5 selection 0	P5SEL0	0Ah
Port P5 selection 1	P5SEL1	0Ch
Port P5 interrupt vector word	P5IV	0Eh
Port P5 complement selection	P5SELC	16h
Port P5 interrupt edge select	P5IES	18h
Port P5 interrupt enable	P5IE	1Ah
Port P5 interrupt flag	P5IFG	1Ch
Port P6 input	P6IN	01h
Port P6 output	P6OUT	03h
Port P6 direction	P6DIR	05h
Port P6 resistor enable	P6REN	07h
Port P6 selection 0	P6SEL0	0Bh
Port P6 selection 1	P6SEL1	0Dh
Port P6 complement selection	P6SELC	17h
Port P6 interrupt vector word	P6IV	1Eh
Port P6 interrupt edge select	P6IES	19h
Port P6 interrupt enable	P6IE	1Bh
Port P6 interrupt flag	P6IFG	1Dh

Table 9-55. Port P7, P8 Registers (Base Address: 0260h)

REGISTER DESCRIPTION	ACRONYM	OFFSET
Port P7 input	P7IN	00h
Port P7 output	P7OUT	02h
Port P7 direction	P7DIR	04h
Port P7 resistor enable	P7REN	06h
Port P7 selection 0	P7SEL0	0Ah
Port P7 selection 1	P7SEL1	0Ch
Port P7 interrupt vector word	P7IV	0Eh
Port P7 complement selection	P7SELC	16h
Port P7 interrupt edge select	P7IES	18h
Port P7 interrupt enable	P7IE	1Ah
Port P7 interrupt flag	P7IFG	1Ch
Port P8 input	P8IN	01h
Port P8 output	P8OUT	03h
Port P8 direction	P8DIR	05h
Port P8 resistor enable	P8REN	07h
Port P8 selection 0	P8SEL0	0Bh
Port P8 selection 1	P8SEL1	0Dh
Port P8 complement selection	P8SELC	17h
Port P8 interrupt vector word	P8IV	1Eh
Port P8 interrupt edge select	P8IES	19h
Port P8 interrupt enable	P8IE	1Bh
Port P8 interrupt flag	P8IFG	1Dh

Table 9-56. Port PJ Registers (Base Address: 0320h)

REGISTER DESCRIPTION	ACRONYM	OFFSET
Port PJ input	PJIN	00h
Port PJ output	PJOUT	02h
Port PJ direction	PJDIR	04h
Port PJ resistor enable	PJREN	06h
Port PJ selection 0	PJSEL0	0Ah
Port PJ selection 1	PJSEL1	0Ch
Port PJ complement selection	PJSELC	16h

Table 9-57. TA0 Registers (Base Address: 0340h)

REGISTER DESCRIPTION	ACRONYM	OFFSET
TA0 control	TA0CTL	00h
Capture/compare control 0	TA0CCTL0	02h
Capture/compare control 1	TA0CCTL1	04h
Capture/compare control 2	TA0CCTL2	06h
TA0 counter	TA0R	10h
Capture/compare 0	TA0CCR0	12h
Capture/compare 1	TA0CCR1	14h
Capture/compare 2	TA0CCR2	16h
TA0 expansion 0	TA0EX0	20h
TA0 interrupt vector	TA0IV	2Eh

Table 9-58. TA1 Registers (Base Address: 0380h)

REGISTER DESCRIPTION	ACRONYM	OFFSET
TA1 control	TA1CTL	00h
Capture/compare control 0	TA1CCTL0	02h
Capture/compare control 1	TA1CCTL1	04h
Capture/compare control 2	TA1CCTL2	06h
TA1 counter	TA1R	10h
Capture/compare 0	TA1CCR0	12h
Capture/compare 1	TA1CCR1	14h
Capture/compare 2	TA1CCR2	16h
TA1 expansion 0	TA1EX0	20h
TA1 interrupt vector	TA1IV	2Eh

Table 9-59. TB0 Registers (Base Address: 03C0h)

REGISTER DESCRIPTION	ACRONYM	OFFSET
TB0 control	TB0CTL	00h
Capture/compare control 0	TB0CCTL0	02h
Capture/compare control 1	TB0CCTL1	04h
Capture/compare control 2	TB0CCTL2	06h
Capture/compare control 3	TB0CCTL3	08h
Capture/compare control 4	TB0CCTL4	0Ah
Capture/compare control 5	TB0CCTL5	0Ch
Capture/compare control 6	TB0CCTL6	0Eh
TB0 counter	TB0R	10h
Capture/compare 0	TB0CCR0	12h
Capture/compare 1	TB0CCR1	14h
Capture/compare 2	TB0CCR2	16h
Capture/compare 3	TB0CCR3	18h
Capture/compare 4	TB0CCR4	1Ah
Capture/compare 5	TB0CCR5	1Ch
Capture/compare 6	TB0CCR6	1Eh
TB0 expansion 0	TB0EX0	20h
TB0 interrupt vector	TB0IV	2Eh

Table 9-60. TA2 Registers (Base Address: 0400h)

REGISTER DESCRIPTION	ACRONYM	OFFSET
TA2 control	TA2CTL	00h
Capture/compare control 0	TA2CCTL0	02h
Capture/compare control 1	TA2CCTL1	04h
TA2 counter	TA2R	10h
Capture/compare 0	TA2CCR0	12h
Capture/compare 1	TA2CCR1	14h
TA2 expansion 0	TA2EX0	20h
TA2 interrupt vector	TA2IV	2Eh

Table 9-61. Capacitive Touch I/O 0 Registers (Base Address: 0430h)

REGISTER DESCRIPTION	ACRONYM	OFFSET
Capacitive Touch I/O 0 control	CAPTIO0CTL	0Eh

Table 9-62. TA3 Registers (Base Address: 0440h)

REGISTER DESCRIPTION	ACRONYM	OFFSET
TA3 control	TA3CTL	00h
Capture/compare control 0	TA3CCTL0	02h
Capture/compare control 1	TA3CCTL1	04h
TA3 counter	TA3R	10h
Capture/compare 0	TA3CCR0	12h
Capture/compare 1	TA3CCR1	14h
TA3 expansion 0	TA3EX0	20h
TA3 interrupt vector	TA3IV	2Eh

Table 9-63. Capacitive Touch I/O 1 Registers (Base Address: 0470h)

REGISTER DESCRIPTION	ACRONYM	OFFSET
Capacitive Touch I/O 1 control	CAPTIO1CTL	0Eh

Table 9-64. RTC_C Registers (Base Address: 04A0h)

REGISTER DESCRIPTION	ACRONYM	OFFSET
RTC control 0	RTCCTL0	00h
RTC password	RTCPWD	01h
RTC control 1	RTCCTL1	02h
RTC control 3	RTCCTL3	03h
RTC offset calibration	RTCOCAL	04h
RTC temperature compensation	RTCTCMP	06h
RTC prescaler 0 control	RTCPS0CTL	08h
RTC prescaler 1 control	RTCPS1CTL	0Ah
RTC prescaler 0	RTCPS0	0Ch
RTC prescaler 1	RTCPS1	0Dh
RTC interrupt vector word	RTCIV	0Eh
RTC seconds/counter 1	RTCSEC/RTCNT1	10h
RTC minutes/counter 2	RTCMIN/RTCNT2	11h
RTC hours/counter 3	RTCHOUR/RTCNT3	12h
RTC day of week/counter 4	RTCDOW/RTCNT4	13h
RTC days	RTCDAY	14h
RTC month	RTCMON	15h
RTC year	RTCYEAR	16h
RTC alarm minutes	RTCAMIN	18h
RTC alarm hours	RTCAHOUR	19h
RTC alarm day of week	RTCADOW	1Ah
RTC alarm days	RTCADAY	1Bh
Binary-to-BCD conversion	BIN2BCD	1Ch
BCD-to-binary conversion	BCD2BIN	1Eh

Table 9-65. 32-Bit Hardware Multiplier Registers (Base Address: 04C0h)

REGISTER DESCRIPTION	ACRONYM	OFFSET
16-bit operand 1 – multiply	MPY	00h
16-bit operand 1 – signed multiply	MPYS	02h
16-bit operand 1 – multiply accumulate	MAC	04h
16-bit operand 1 – signed multiply accumulate	MACS	06h
16-bit operand 2	OP2	08h
16 × 16 result low word	RESLO	0Ah
16 × 16 result high word	RESHI	0Ch
16 × 16 sum extension	SUMEXT	0Eh
32-bit operand 1 – multiply low word	MPY32L	10h
32-bit operand 1 – multiply high word	MPY32H	12h
32-bit operand 1 – signed multiply low word	MPYS32L	14h
32-bit operand 1 – signed multiply high word	MPYS32H	16h
32-bit operand 1 – multiply accumulate low word	MAC32L	18h
32-bit operand 1 – multiply accumulate high word	MAC32H	1Ah
32-bit operand 1 – signed multiply accumulate low word	MACS32L	1Ch
32-bit operand 1 – signed multiply accumulate high word	MACS32H	1Eh
32-bit operand 2 – low word	OP2L	20h
32-bit operand 2 – high word	OP2H	22h
32 × 32 result 0 – least significant word	RES0	24h
32 × 32 result 1	RES1	26h
32 × 32 result 2	RES2	28h
32 × 32 result 3 – most significant word	RES3	2Ah
MPY32 control 0	MPY32CTL0	2Ch

**Table 9-66. DMA Registers (Base Address DMA General Control: 0500h,
Channel 0: 0510h, Channel 1: 0520h, Channel 2: 0530h,
Channel 3: 0540h, Channel 4: 0550h, Channel 5: 0560h)**

REGISTER DESCRIPTION	ACRONYM	OFFSET
DMA channel 0 control	DMA0CTL	00h
DMA channel 0 source address low	DMA0SAL	02h
DMA channel 0 source address high	DMA0SAH	04h
DMA channel 0 destination address low	DMA0DAL	06h
DMA channel 0 destination address high	DMA0DAH	08h
DMA channel 0 transfer size	DMA0SZ	0Ah
DMA channel 1 control	DMA1CTL	00h
DMA channel 1 source address low	DMA1SAL	02h
DMA channel 1 source address high	DMA1SAH	04h
DMA channel 1 destination address low	DMA1DAL	06h
DMA channel 1 destination address high	DMA1DAH	08h
DMA channel 1 transfer size	DMA1SZ	0Ah
DMA channel 2 control	DMA2CTL	00h
DMA channel 2 source address low	DMA2SAL	02h
DMA channel 2 source address high	DMA2SAH	04h
DMA channel 2 destination address low	DMA2DAL	06h
DMA channel 2 destination address high	DMA2DAH	08h
DMA channel 2 transfer size	DMA2SZ	0Ah
DMA channel 3 control	DMA3CTL	00h
DMA channel 3 source address low	DMA3SAL	02h
DMA channel 3 source address high	DMA3SAH	04h
DMA channel 3 destination address low	DMA3DAL	06h
DMA channel 3 destination address high	DMA3DAH	08h
DMA channel 3 transfer size	DMA3SZ	0Ah
DMA channel 4 control	DMA4CTL	00h
DMA channel 4 source address low	DMA4SAL	02h
DMA channel 4 source address high	DMA4SAH	04h
DMA channel 4 destination address low	DMA4DAL	06h
DMA channel 4 destination address high	DMA4DAH	08h
DMA channel 4 transfer size	DMA4SZ	0Ah
DMA channel 5 control	DMA5CTL	00h
DMA channel 5 source address low	DMA5SAL	02h
DMA channel 5 source address high	DMA5SAH	04h
DMA channel 5 destination address low	DMA5DAL	06h
DMA channel 5 destination address high	DMA5DAH	08h
DMA channel 5 transfer size	DMA5SZ	0Ah
DMA module control 0	DMACTL0	00h
DMA module control 1	DMACTL1	02h
DMA module control 2	DMACTL2	04h
DMA module control 3	DMACTL3	06h
DMA module control 4	DMACTL4	08h
DMA interrupt vector	DMAIV	0Eh

Table 9-67. MPU Control Registers (Base Address: 05A0h)

REGISTER DESCRIPTION	ACRONYM	OFFSET
MPU control 0	MPUCTL0	00h
MPU control 1	MPUCTL1	02h
MPU segmentation border 2	MPUSEGB2	04h
MPU segmentation border 1	MPUSEGB1	06h
MPU access management	MPUSAM	08h
MPU IP control 0	MPUIPC0	0Ah
MPU IP encapsulation segment border 2	MPUIPSEGB2	0Ch
MPU IP encapsulation segment border 1	MPUIPSEGB1	0Eh

Table 9-68. eUSCI_A0 Registers (Base Address: 05C0h)

REGISTER DESCRIPTION	ACRONYM	OFFSET
eUSCI_A control word 0	UCA0CTLW0	00h
eUSCI_A control word 1	UCA0CTLW1	02h
eUSCI_A baud rate 0	UCA0BR0	06h
eUSCI_A baud rate 1	UCA0BR1	07h
eUSCI_A modulation control	UCA0MCTLW	08h
eUSCI_A status word	UCA0STATW	0Ah
eUSCI_A receive buffer	UCA0RXBUF	0Ch
eUSCI_A transmit buffer	UCA0TXBUF	0Eh
eUSCI_A LIN control	UCA0ABCTL	10h
eUSCI_A IrDA transmit control	UCA0IRTCTL	12h
eUSCI_A IrDA receive control	UCA0IRRCTL	13h
eUSCI_A interrupt enable	UCA0IE	1Ah
eUSCI_A interrupt flags	UCA0IFG	1Ch
eUSCI_A interrupt vector word	UCA0IV	1Eh

Table 9-69. eUSCI_A1 Registers (Base Address:05E0h)

REGISTER DESCRIPTION	ACRONYM	OFFSET
eUSCI_A control word 0	UCA1CTLW0	00h
eUSCI_A control word 1	UCA1CTLW1	02h
eUSCI_A baud rate 0	UCA1BR0	06h
eUSCI_A baud rate 1	UCA1BR1	07h
eUSCI_A modulation control	UCA1MCTLW	08h
eUSCI_A status word	UCA1STATW	0Ah
eUSCI_A receive buffer	UCA1RXBUF	0Ch
eUSCI_A transmit buffer	UCA1TXBUF	0Eh
eUSCI_A LIN control	UCA1ABCTL	10h
eUSCI_A IrDA transmit control	UCA1IRTCTL	12h
eUSCI_A IrDA receive control	UCA1IRRCTL	13h
eUSCI_A interrupt enable	UCA1IE	1Ah
eUSCI_A interrupt flags	UCA1IFG	1Ch
eUSCI_A interrupt vector word	UCA1IV	1Eh

Table 9-70. eUSCI_A2 Registers (Base Address:0600h)

REGISTER DESCRIPTION	ACRONYM	OFFSET
eUSCI_A control word 0	UCA2CTLW0	00h
eUSCI_A control word 1	UCA2CTLW1	02h
eUSCI_A baud rate 0	UCA2BR0	06h
eUSCI_A baud rate 1	UCA2BR1	07h
eUSCI_A modulation control	UCA2MCTLW	08h
eUSCI_A status word	UCA2STATW	0Ah
eUSCI_A receive buffer	UCA2RXBUF	0Ch
eUSCI_A transmit buffer	UCA2TXBUF	0Eh
eUSCI_A LIN control	UCA2ABCTL	10h
eUSCI_A IrDA transmit control	UCA2IRTCTL	12h
eUSCI_A IrDA receive control	UCA2IRRCTL	13h
eUSCI_A interrupt enable	UCA2IE	1Ah
eUSCI_A interrupt flags	UCA2IFG	1Ch
eUSCI_A interrupt vector word	UCA2IV	1Eh

Table 9-71. eUSCI_A3 Registers (Base Address:0620h)

REGISTER DESCRIPTION	ACRONYM	OFFSET
eUSCI_A control word 0	UCA3CTLW0	00h
eUSCI_A control word 1	UCA3CTLW1	02h
eUSCI_A baud rate 0	UCA3BR0	06h
eUSCI_A baud rate 1	UCA3BR1	07h
eUSCI_A modulation control	UCA3MCTLW	08h
eUSCI_A status word	UCA3STATW	0Ah
eUSCI_A receive buffer	UCA3RXBUF	0Ch
eUSCI_A transmit buffer	UCA3TXBUF	0Eh
eUSCI_A LIN control	UCA3ABCTL	10h
eUSCI_A IrDA transmit control	UCA3IRTCTL	12h
eUSCI_A IrDA receive control	UCA3IRRCTL	13h
eUSCI_A interrupt enable	UCA3IE	1Ah
eUSCI_A interrupt flags	UCA3IFG	1Ch
eUSCI_A interrupt vector word	UCA3IV	1Eh

Table 9-72. eUSCI_B0 Registers (Base Address: 0640h)

REGISTER DESCRIPTION	ACRONYM	OFFSET
eUSCI_B control word 0	UCB0CTLW0	00h
eUSCI_B control word 1	UCB0CTLW1	02h
eUSCI_B bit rate 0	UCB0BR0	06h
eUSCI_B bit rate 1	UCB0BR1	07h
eUSCI_B status word	UCB0STATW	08h
eUSCI_B byte counter threshold	UCB0TBCNT	0Ah
eUSCI_B receive buffer	UCB0RXBUF	0Ch
eUSCI_B transmit buffer	UCB0TXBUF	0Eh
eUSCI_B I2C own address 0	UCB0I2COA0	14h
eUSCI_B I2C own address 1	UCB0I2COA1	16h
eUSCI_B I2C own address 2	UCB0I2COA2	18h
eUSCI_B I2C own address 3	UCB0I2COA3	1Ah
eUSCI_B received address	UCB0ADDRX	1Ch
eUSCI_B address mask	UCB0ADDMASK	1Eh
eUSCI I2C slave address	UCB0I2CSA	20h
eUSCI interrupt enable	UCB0IE	2Ah
eUSCI interrupt flags	UCB0IFG	2Ch
eUSCI interrupt vector word	UCB0IV	2Eh

Table 9-73. eUSCI_B1 Registers (Base Address: 0680h)

REGISTER DESCRIPTION	ACRONYM	OFFSET
eUSCI_B control word 0	UCB1CTLW0	00h
eUSCI_B control word 1	UCB1CTLW1	02h
eUSCI_B bit rate 0	UCB1BR0	06h
eUSCI_B bit rate 1	UCB1BR1	07h
eUSCI_B status word	UCB1STATW	08h
eUSCI_B byte counter threshold	UCB1TBCNT	0Ah
eUSCI_B receive buffer	UCB1RXBUF	0Ch
eUSCI_B transmit buffer	UCB1TXBUF	0Eh
eUSCI_B I2C own address 0	UCB1I2COA0	14h
eUSCI_B I2C own address 1	UCB1I2COA1	16h
eUSCI_B I2C own address 2	UCB1I2COA2	18h
eUSCI_B I2C own address 3	UCB1I2COA3	1Ah
eUSCI_B received address	UCB1ADDRX	1Ch
eUSCI_B address mask	UCB1ADDMASK	1Eh
eUSCI I2C slave address	UCB1I2CSA	20h
eUSCI interrupt enable	UCB1IE	2Ah
eUSCI interrupt flags	UCB1IFG	2Ch
eUSCI interrupt vector word	UCB1IV	2Eh

Table 9-74. eUSCI_B2 Registers (Base Address: 06C0h)

REGISTER DESCRIPTION	ACRONYM	OFFSET
eUSCI_B control word 0	UCB2CTLW0	00h
eUSCI_B control word 1	UCB2CTLW1	02h
eUSCI_B bit rate 0	UCB2BR0	06h
eUSCI_B bit rate 1	UCB2BR1	07h
eUSCI_B status word	UCB2STATW	08h
eUSCI_B byte counter threshold	UCB2TBCNT	0Ah
eUSCI_B receive buffer	UCB2RXBUF	0Ch
eUSCI_B transmit buffer	UCB2TXBUF	0Eh
eUSCI_B I2C own address 0	UCB2I2COA0	14h
eUSCI_B I2C own address 1	UCB2I2COA1	16h
eUSCI_B I2C own address 2	UCB2I2COA2	18h
eUSCI_B I2C own address 3	UCB2I2COA3	1Ah
eUSCI_B received address	UCB2ADDRX	1Ch
eUSCI_B address mask	UCB2ADDMASK	1Eh
eUSCI I2C slave address	UCB2I2CSA	20h
eUSCI interrupt enable	UCB2IE	2Ah
eUSCI interrupt flags	UCB2IFG	2Ch
eUSCI interrupt vector word	UCB2IV	2Eh

Table 9-75. eUSCI_B3 Registers (Base Address: 0700h)

REGISTER DESCRIPTION	ACRONYM	OFFSET
eUSCI_B control word 0	UCB3CTLW0	00h
eUSCI_B control word 1	UCB3CTLW1	02h
eUSCI_B bit rate 0	UCB3BR0	06h
eUSCI_B bit rate 1	UCB3BR1	07h
eUSCI_B status word	UCB3STATW	08h
eUSCI_B byte counter threshold	UCB3TBCNT	0Ah
eUSCI_B receive buffer	UCB3RXBUF	0Ch
eUSCI_B transmit buffer	UCB3TXBUF	0Eh
eUSCI_B I2C own address 0	UCB3I2COA0	14h
eUSCI_B I2C own address 1	UCB3I2COA1	16h
eUSCI_B I2C own address 2	UCB3I2COA2	18h
eUSCI_B I2C own address 3	UCB3I2COA3	1Ah
eUSCI_B received address	UCB3ADDRX	1Ch
eUSCI_B address mask	UCB3ADDMASK	1Eh
eUSCI I2C slave address	UCB3I2CSA	20h
eUSCI interrupt enable	UCB3IE	2Ah
eUSCI interrupt flags	UCB3IFG	2Ch
eUSCI interrupt vector word	UCB3IV	2Eh

Table 9-76. TA4 Registers (Base Address: 07C0h)

REGISTER DESCRIPTION	ACRONYM	OFFSET
TA4 control	TA4CTL	00h
Capture/compare control 0	TA4CCTL0	02h
Capture/compare control 1	TA4CCTL1	04h
TA4 counter	TA4R	10h
Capture/compare 0	TA4CCR0	12h
Capture/compare 1	TA4CCR1	14h
TA4 expansion 0	TA4EX0	20h
TA4 interrupt vector	TA4IV	2Eh

Table 9-77. ADC12_B Registers (Base Address: 0800h)

REGISTER DESCRIPTION	ACRONYM	OFFSET
ADC12_B control 0	ADC12CTL0	00h
ADC12_B control 1	ADC12CTL1	02h
ADC12_B control 2	ADC12CTL2	04h
ADC12_B control 3	ADC12CTL3	06h
ADC12_B window comparator low threshold register	ADC12LO	08h
ADC12_B window comparator high threshold register	ADC12HI	0Ah
ADC12_B interrupt flag register 0	ADC12IFGR0	0Ch
ADC12_B interrupt flag register 1	ADC12IFGR1	0Eh
ADC12_B interrupt flag register 2	ADC12IFGR2	10h
ADC12_B interrupt enable register 0	ADC12IER0	12h
ADC12_B interrupt enable register 1	ADC12IER1	14h
ADC12_B interrupt enable register 2	ADC12IER2	16h
ADC12_B interrupt vector	ADC12IV	18h
ADC12_B memory control 0	ADC12MCTL0	20h
ADC12_B memory control 1	ADC12MCTL1	22h
ADC12_B memory control 2	ADC12MCTL2	24h
ADC12_B memory control 3	ADC12MCTL3	26h
ADC12_B memory control 4	ADC12MCTL4	28h
ADC12_B memory control 5	ADC12MCTL5	2Ah
ADC12_B memory control 6	ADC12MCTL6	2Ch
ADC12_B memory control 7	ADC12MCTL7	2Eh
ADC12_B memory control 8	ADC12MCTL8	30h
ADC12_B memory control 9	ADC12MCTL9	32h
ADC12_B memory control 10	ADC12MCTL10	34h
ADC12_B memory control 11	ADC12MCTL11	36h
ADC12_B memory control 12	ADC12MCTL12	38h
ADC12_B memory control 13	ADC12MCTL13	3Ah
ADC12_B memory control 14	ADC12MCTL14	3Ch
ADC12_B memory control 15	ADC12MCTL15	3Eh
ADC12_B memory control 16	ADC12MCTL16	40h
ADC12_B memory control 17	ADC12MCTL17	42h
ADC12_B memory control 18	ADC12MCTL18	44h
ADC12_B memory control 19	ADC12MCTL19	46h
ADC12_B memory control 20	ADC12MCTL20	48h
ADC12_B memory control 21	ADC12MCTL21	4Ah

Table 9-77. ADC12_B Registers (Base Address: 0800h) (continued)

REGISTER DESCRIPTION	ACRONYM	OFFSET
ADC12_B memory control 22	ADC12MCTL22	4Ch
ADC12_B memory control 23	ADC12MCTL23	4Eh
ADC12_B memory control 24	ADC12MCTL24	50h
ADC12_B memory control 25	ADC12MCTL25	52h
ADC12_B memory control 26	ADC12MCTL26	54h
ADC12_B memory control 27	ADC12MCTL27	56h
ADC12_B memory control 28	ADC12MCTL28	58h
ADC12_B memory control 29	ADC12MCTL29	5Ah
ADC12_B memory control 30	ADC12MCTL30	5Ch
ADC12_B memory control 31	ADC12MCTL31	5Eh
ADC12_B memory 0	ADC12MEM0	60h
ADC12_B memory 1	ADC12MEM1	62h
ADC12_B memory 2	ADC12MEM2	64h
ADC12_B memory 3	ADC12MEM3	66h
ADC12_B memory 4	ADC12MEM4	68h
ADC12_B memory 5	ADC12MEM5	6Ah
ADC12_B memory 6	ADC12MEM6	6Ch
ADC12_B memory 7	ADC12MEM7	6Eh
ADC12_B memory 8	ADC12MEM8	70h
ADC12_B memory 9	ADC12MEM9	72h
ADC12_B memory 10	ADC12MEM10	74h
ADC12_B memory 11	ADC12MEM11	76h
ADC12_B memory 12	ADC12MEM12	78h
ADC12_B memory 13	ADC12MEM13	7Ah
ADC12_B memory 14	ADC12MEM14	7Ch
ADC12_B memory 15	ADC12MEM15	7Eh
ADC12_B memory 16	ADC12MEM16	80h
ADC12_B memory 17	ADC12MEM17	82h
ADC12_B memory 18	ADC12MEM18	84h
ADC12_B memory 19	ADC12MEM19	86h
ADC12_B memory 20	ADC12MEM20	88h
ADC12_B memory 21	ADC12MEM21	8Ah
ADC12_B memory 22	ADC12MEM22	8Ch
ADC12_B memory 23	ADC12MEM23	8Eh
ADC12_B memory 24	ADC12MEM24	90h
ADC12_B memory 25	ADC12MEM25	92h
ADC12_B memory 26	ADC12MEM26	94h
ADC12_B memory 27	ADC12MEM27	96h
ADC12_B memory 28	ADC12MEM28	98h
ADC12_B memory 29	ADC12MEM29	9Ah
ADC12_B memory 30	ADC12MEM30	9Ch
ADC12_B memory 31	ADC12MEM31	9Eh

Table 9-78. Comparator_E Registers (Base Address: 08C0h)

REGISTER DESCRIPTION	ACRONYM	OFFSET
Comparator_E control 0	CECTL0	00h
Comparator_E control 1	CECTL1	02h
Comparator_E control 2	CECTL2	04h
Comparator_E control 3	CECTL3	06h
Comparator_E interrupt	CEINT	0Ch
Comparator_E interrupt vector word	CEIV	0Eh

Table 9-79. CRC32 Registers (Base Address: 0980h)

REGISTER DESCRIPTION	ACRONYM	OFFSET
CRC32 data input	CRC32DIW0	00h
Reserved		02h
Reserved		04h
CRC32 data input reverse	CRC32DIRBW0	06h
CRC32 initialization and result word 0	CRC32INIRESW0	08h
CRC32 initialization and result word 1	CRC32INIRESW1	0Ah
CRC32 result reverse word 1	CRC32RESRW1	0Ch
CRC32 result reverse word 0	CRC32RESRW0	0Eh
CRC16 data input	CRC16DIW0	10h
Reserved		12h
Reserved		14h
CRC16 data input reverse	CRC16DIRBW0	16h
CRC16 initialization and result word 0	CRC16INIRESW0	18h
Reserved		1Ah
Reserved		1Ch
CRC16 result reverse word 0	CRC16RESRW0	1Eh
Reserved		20h
Reserved		22h
Reserved		24h
Reserved		26h
Reserved		28h
Reserved		2Ah
Reserved		2Ch
Reserved		2Eh

Table 9-80. AES Accelerator Registers (Base Address: 09C0h)

REGISTER DESCRIPTION	ACRONYM	OFFSET
AES accelerator control 0	AESACTL0	00h
Reserved		02h
AES accelerator status	AESASTAT	04h
AES accelerator key	AESAKEY	06h
AES accelerator data in	AESADIN	008h
AES accelerator data out	AESADOUT	00Ah
AES accelerator XORed data in	AESAXDIN	00Ch
AES accelerator XORed data in (no trigger)	AESAXIN	00Eh

9.16 Identification

9.16.1 Revision Identification

The device revision information is shown as part of the top-side marking on the device package. The device-specific errata sheet describes these markings. For links to all of the errata sheets for the devices in this data sheet, see [Section 11.4](#).

The hardware revision is also stored in the Device Descriptor structure in the Info Block section. For details on this value, see the Hardware Revision entry in [Section 9.14](#).

9.16.2 Device Identification

The device type can be identified from the top-side marking on the device package. The device-specific errata sheet describes these markings. For links to all of the errata sheets for the devices in this data sheet, see [Section 11.4](#).

A device identification value is also stored in the Device Descriptor structure in the Info Block section. For details on this value, see the Device ID entry in [Section 9.14](#).

9.16.3 JTAG Identification

Programming through the JTAG interface, including reading and identifying the JTAG ID, is described in detail in [MSP430 Programming With the JTAG Interface](#).

10 Applications, Implementation, and Layout

Note

Information in the following Applications section is not part of the TI component specification, and TI does not warrant its accuracy or completeness. TI's customers are responsible for determining suitability of components for their purposes. Customers should validate and test their design implementation to confirm system functionality.

10.1 Device Connection and Layout Fundamentals

This section discusses the recommended guidelines when designing with the MSP MCU. These guidelines are to make sure that the device has proper connections for powering, programming, debugging, and optimum analog performance.

10.1.1 Power Supply Decoupling and Bulk Capacitors

TI recommends connecting a combination of a 1- μ F plus a 100-nF low-ESR ceramic decoupling capacitor to each AVCC and DVCC pin. Higher-value capacitors may be used but can impact supply rail ramp-up time. Decoupling capacitors must be placed as close as possible to the pins that they decouple (within a few millimeters). Additionally, TI recommends separated grounds with a single-point connection for better noise isolation from digital to analog circuits on the board and to achieve high analog accuracy.

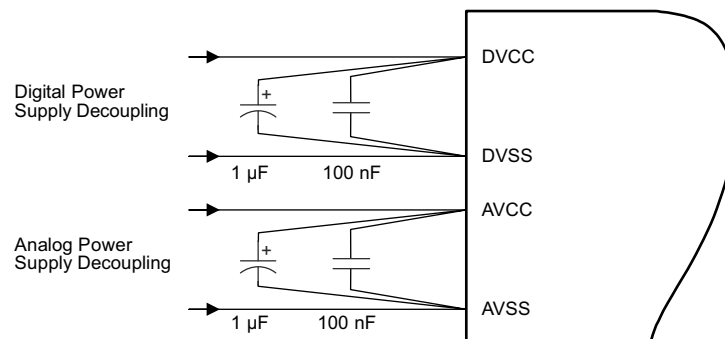

Figure 10-1. Power Supply Decoupling

10.1.2 External Oscillator

Depending on the device variant (see [Section 6](#)), the device can support a low-frequency crystal (32 kHz) on the LFXT pins, a high-frequency crystal on the HFXT pins, or both. External bypass capacitors for the crystal oscillator pins are required.

It is also possible to apply digital clock signals to the LFXIN and HFXIN input pins that meet the specifications of the respective oscillator if the appropriate LFXTBYPASS or HFXTBYPASS mode is selected. In this case, the associated LFXOUT and HFXOUT pins can be used for other purposes. If they are left unused, they must be terminated according to [Section 7.6](#).

[Figure 10-2](#) shows a typical connection diagram.

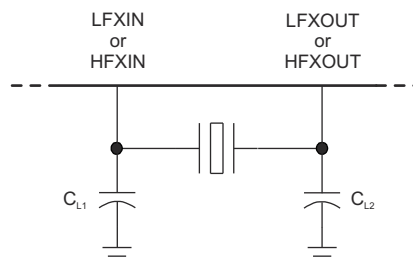

Figure 10-2. Typical Crystal Connection

See [MSP430 32-kHz Crystal Oscillators](#) for more information on selecting, testing, and designing a crystal oscillator with the MSP MCUs.

10.1.3 JTAG

With the proper connections, the debugger and a hardware JTAG interface (such as the MSP-FET or MSP-FET430UIF) can be used to program and debug code on the target board. In addition, the connections also support the MSP-GANG production programmers, thus providing an easy way to program prototype boards, if desired. [Figure 10-3](#) shows the connections between the 14-pin JTAG connector and the target device required to support in-system programming and debugging for 4-wire JTAG communication. [Figure 10-4](#) shows the connections for 2-wire JTAG mode (Spy-Bi-Wire).

The connections for the MSP-FET and MSP-FET430UIF interface modules and the MSP-GANG are identical. Both can supply VCC to the target board (through pin 2). In addition, the MSP-FET and MSP-FET430UIF interface modules and MSP-GANG have a VCC sense feature that, if used, requires an alternate connection (pin 4 instead of pin 2). The VCC-sense feature senses the local VCC present on the target board (that is, a battery or other local power supply) and adjusts the output signals accordingly. [Figure 10-3](#) and [Figure 10-4](#) show a jumper block that supports both scenarios of supplying VCC to the target board. If this flexibility is not required, the desired VCC connections may be hard-wired to eliminate the jumper block. Pins 2 and 4 must not be connected at the same time.

For additional design information regarding the JTAG interface, see the [MSP430 Hardware Tools User's Guide](#).

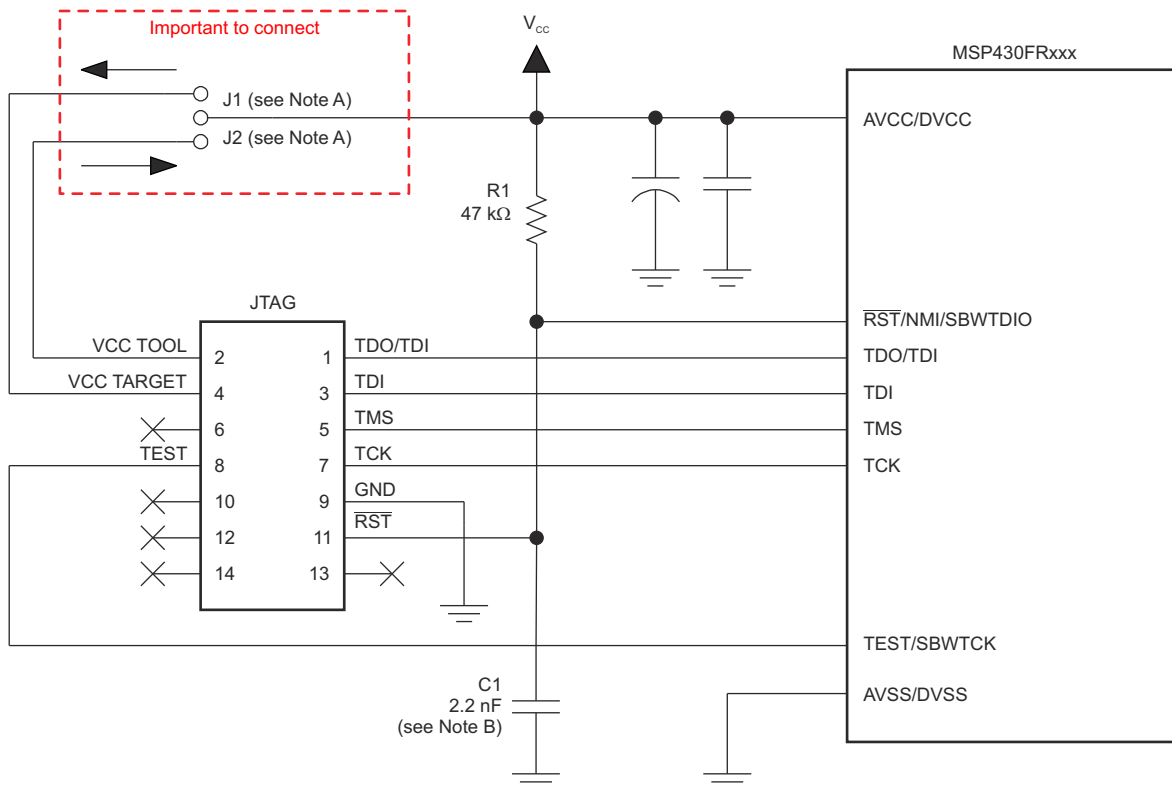

Copyright © 2016, Texas Instruments Incorporated

- A. If a local target power supply is used, make connection J1. If power from the debug or programming adapter is used, make connection J2.
- B. The upper limit for C1 is 2.2 nF when using current TI tools.

Figure 10-3. Signal Connections for 4-Wire JTAG Communication

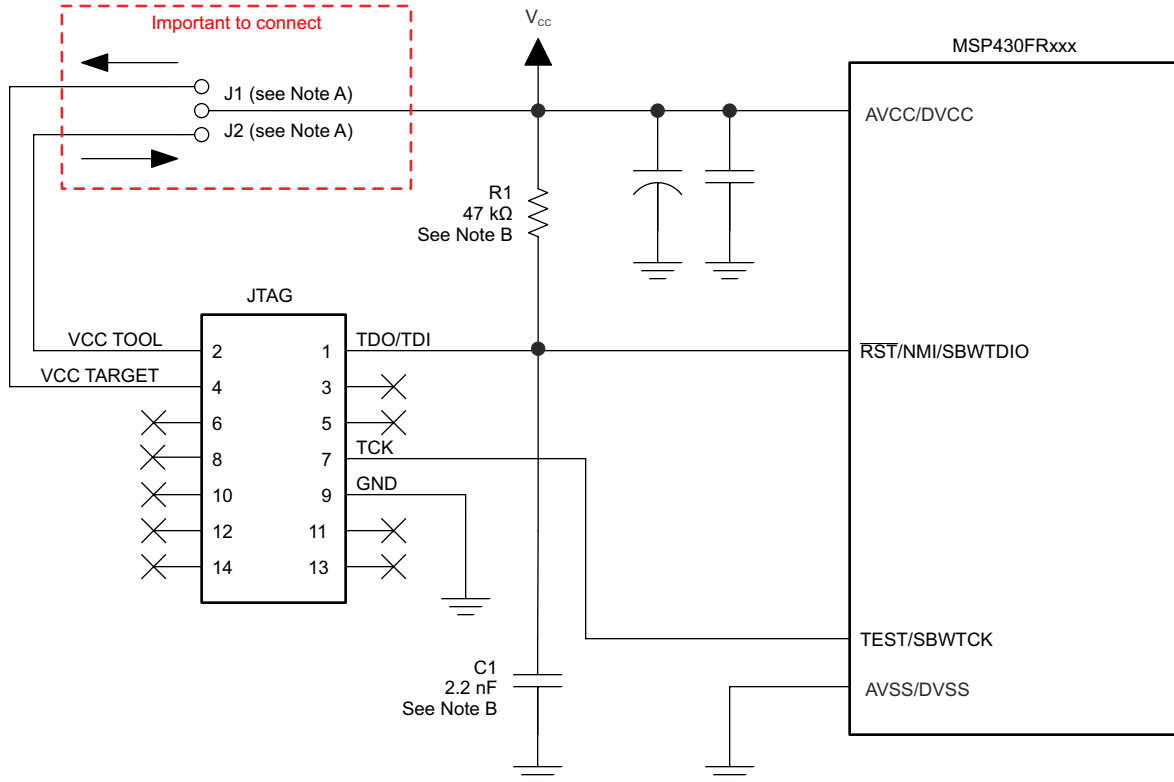

Copyright © 2016, Texas Instruments Incorporated

- Make connection J1 if a local target power supply is used, or make connection J2 if the target is powered from the debug or programming adapter.
- The device $\overline{\text{RST}}/\text{NMI}/\text{SBWT DIO}$ pin is used in 2-wire mode for bidirectional communication with the device during JTAG access, and any capacitance that is attached to this signal may affect the ability to establish a connection with the device. The upper limit for C1 is 2.2 nF when using current TI tools.

Figure 10-4. Signal Connections for 2-Wire JTAG Communication (Spy-Bi-Wire)

10.1.4 Reset

The reset pin can be configured as a reset function (default) or as an NMI function in the SFRRPCR register.

In reset mode, the $\overline{\text{RST}}/\text{NMI}$ pin is active low, and a pulse applied to this pin that meets the reset timing specifications generates a BOR-type device reset.

Setting SYSNMI causes the $\overline{\text{RST}}/\text{NMI}$ pin to be configured as an external NMI source. The external NMI is edge sensitive, and its edge is selectable by SYSNMIIES. Setting the NMIIE enables the interrupt of the external NMI. When an external NMI event occurs, the NMIIFG is set.

The $\overline{\text{RST}}/\text{NMI}$ pin can have either a pullup or pulldown that is enabled or not. SYSRSTUP selects either pullup or pulldown, and SYSRSTRE causes the pullup (default) or pulldown to be enabled (default) or not. If the $\overline{\text{RST}}/\text{NMI}$ pin is unused, it is required either to select and enable the internal pullup or to connect an external 47-kΩ pullup resistor to the $\overline{\text{RST}}/\text{NMI}$ pin with a 10-nF pulldown capacitor. The pulldown capacitor should not exceed 2.2 nF when using devices with Spy-Bi-Wire interface in Spy-Bi-Wire mode or in 4-wire JTAG mode with TI tools like FET interfaces or GANG programmers.

See the [MSP430FR58xx](#), [MSP430FR59xx](#), and [MSP430FR6xx Family User's Guide](#) for more information on the referenced control registers and bits.

10.1.5 Unused Pins

For details on the connection of unused pins, see [Section 7.6](#).

10.1.6 General Layout Recommendations

- Proper grounding and short traces for external crystal to reduce parasitic capacitance. See [MSP430 32-kHz Crystal Oscillators](#) for recommended layout guidelines.
- Proper bypass capacitors on DVCC, AVCC, and reference pins if used.
- Avoid routing any high-frequency signal close to an analog signal line. For example, keep digital switching signals such as PWM or JTAG signals away from the oscillator circuit.
- Proper ESD level protection should be considered to protect the device from unintended high-voltage electrostatic discharge. See [MSP430 System-Level ESD Considerations](#) for guidelines.

10.1.7 Do's and Don'ts

TI recommends powering AVCC and DVCC pins from the same source. At a minimum, during power up, power down, and device operation, the voltage difference between AVCC and DVCC must not exceed the limits specified in [Section 8.1](#). Exceeding the specified limits may cause malfunction of the device, including erroneous writes to RAM and FRAM.

10.2 Peripheral- and Interface-Specific Design Information

10.2.1 ADC12_B Peripheral

10.2.1.1 Partial Schematic

[Figure 10-5](#) shows the recommended decoupling circuit when an external voltage reference is used. The internal reference module has a maximum drive current as specified in the $I_{O(VREF+)}$ parameter of the REF module.

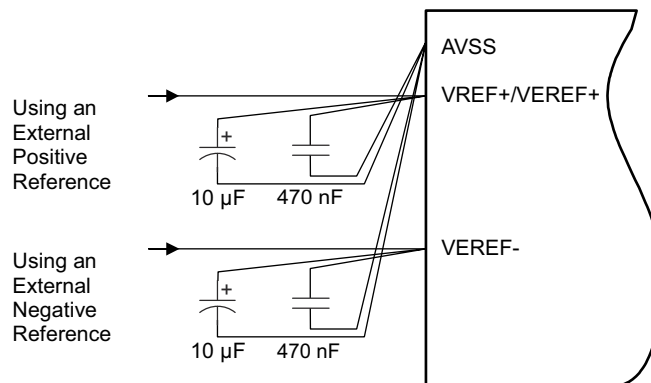

Figure 10-5. ADC12_B Grounding and Noise Considerations

10.2.1.2 Design Requirements

As with any high-resolution ADC, the appropriate printed-circuit-board layout and grounding techniques should be followed to eliminate ground loops, unwanted parasitic effects, and noise.

Ground loops are formed when return current from the ADC flows through paths that are common with other analog or digital circuitry. If care is not taken, this current can generate small, unwanted offset voltages that can add to or subtract from the reference or input voltages of the ADC. The general guidelines in [Section 10.1.1](#), combined with the connections shown in [Section 10.2.1.1](#), prevent these offsets.

In addition to grounding, ripple and noise spikes on the power-supply lines that are caused by digital switching or switching power supplies can corrupt the conversion result. TI recommends a noise-free design using separate analog and digital ground planes with a single-point connection to achieve high accuracy.

The reference voltage must be a stable voltage for accurate measurements. The capacitor values that are selected in the general guidelines filter out the high- and low-frequency ripple before the reference voltage enters the device. In this case, the 10-µF capacitor is used to buffer the reference pin and filter any low-frequency ripple. A 470-nF bypass capacitor filters out any high-frequency noise.

10.2.1.3 Detailed Design Procedure

For additional design information, see [Designing With the MSP430FR58xx, FR59xx, FR68xx, and FR69xx ADC](#).

10.2.1.4 Layout Guidelines

Components that are shown in the partial schematic (see [Figure 10-5](#)) should be placed as close as possible to the respective device pins. Avoid long traces, because they add additional parasitic capacitance, inductance, and resistance on the signal.

Avoid routing analog input signals close to a high-frequency pin (for example, a high-frequency PWM), because the high-frequency switching can be coupled into the analog signal.

If differential mode is used for the ADC12_B, the analog differential input signals must be routed closely together to minimize the effect of noise on the resulting signal.

11 Device and Documentation Support

11.1 Getting Started

For more information on the MSP family of microcontrollers and the tools and libraries that are available to help with your development, visit the [MSP430 ultra-low-power sensing & measurement MCUs overview](#).

11.2 Device Nomenclature

To designate the stages in the product development cycle, TI assigns prefixes to the part numbers of all MSP MCU devices. Each MSP MCU commercial family member has one of two prefixes: MSP or XMS. These prefixes represent evolutionary stages of product development from engineering prototypes (XMS) through fully qualified production devices (MSP).

XMS – Experimental device that is not necessarily representative of the final device's electrical specifications

MSP – Fully qualified production device

XMS devices are shipped against the following disclaimer:

"Developmental product is intended for internal evaluation purposes."

MSP devices have been characterized fully, and the quality and reliability of the device have been demonstrated fully. TI's standard warranty applies.

Predictions show that prototype devices (XMS) have a greater failure rate than the standard production devices. TI recommends that these devices not be used in any production system because their expected end-use failure rate still is undefined. Only qualified production devices are to be used.

TI device nomenclature also includes a suffix with the device family name. This suffix indicates the temperature range, package type, and distribution format. [Figure 11-1](#) provides a legend for reading the complete device name.

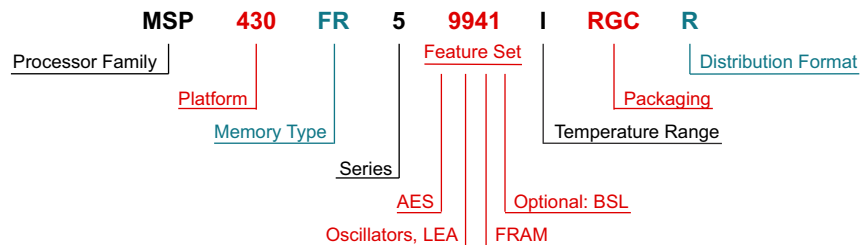

Processor Family	MSP = Mixed Signal Processor XMS = Experimental Silicon			
Platform	430 = TI's 16-bit MSP430 Low-Power Microcontroller Platform			
Memory Type	FR = FRAM			
Series	5 = Up to 16 MHz without LCD			
Feature Set	First Digit: AES 9 = AES	Second Digit: Oscillators, LEA 9 = HFXT/LFXT and LEA 6 = HFXT/LFXT	Third Digit: FRAM (KB) 4 = 256 2 = 128	Optional Fourth Digit: BSL 1 = 1°C No value = UART
Temperature Range	I = -40°C to 85°C			
Packaging	www.ti.com/packaging			
Distribution Format	T = Small reel R = Large reel No markings = Tube or tray			

Figure 11-1. Device Nomenclature

11.3 Tools and Software

All MSP microcontrollers are supported by a wide variety of software and hardware development tools. Tools are available from TI and various third parties. See them all at [MSP430 ultra-low-power MCUs – Design & development](#).

Table 11-1 lists the debug features supported in the hardware of the MSP430FR599x and MSP430FR596x MCUs. See the [Code Composer Studio™ IDE for MSP430™ MCUs User's Guide](#) for details on the available hardware features.

Table 11-1. Debug Features

MSP ARCHITECTURE	4-WIRE JTAG	2-WIRE JTAG	BREAK-POINTS (N)	RANGE BREAK-POINTS	CLOCK CONTROL	STATE SEQUENCER	TRACE BUFFER	LPMx.5 DEBUGGING SUPPORT	EnergyTrace++ TECHNOLOGY
MSP430Xv2	Yes	Yes	3	Yes	Yes	No	No	Yes	Yes

EnergyTrace™ technology is supported with Code Composer Studio IDE version 6.0 and newer. It requires specialized debugger circuitry, which is supported with the second-generation onboard eZ-FET flash emulation tool and second-generation stand-alone MSP-FET JTAG emulator. See the following documents for detailed information:

[MSP430 Advanced Power Optimizations: ULP Advisor™ and EnergyTrace™ Technology](#)

[Advanced Debugging Using the Enhanced Emulation Module \(EEM\) With Code Composer Studio™ IDE](#)

[MSP430™ Hardware Tools User's Guide](#)

Design Kits and Evaluation Modules

[MSP430FR5994 LaunchPad™ Development Kit](#)

The MSP-EXP430FR5994 LaunchPad Development Kit is an easy-to-use Evaluation Module (EVM) for the MSP430FR5994 microcontroller (MCU). It contains everything needed to start developing on the ultra-low-power MSP430FRx FRAM microcontroller platform, including an onboard debug probe for programming, debugging, and energy measurements.

[80-pin Target Development Board and MSP-FET Programmer Bundle for MSP430F599x MCUs](#)

The target socket boards allow easy programming and debugging of the device using JTAG. They also feature header pinouts for prototyping. Target socket boards are orderable individually or as a kit with the JTAG programmer and debugger included.

[80-pin Target Development Board for MSP430F599x MCUs](#)

The MSP-TS430PN80B is a stand-alone 80-pin ZIF socket target board that is used to program and debug the MSP430 MCU in-system through the JTAG interface or the Spy Bi-Wire (2-wire JTAG) protocol.

Software

[MSP430Ware™ Software](#)

MSP430Ware software is a collection of code examples, data sheets, and other design resources for all MSP430 devices delivered in a convenient package. In addition to providing a complete collection of existing MSP430 MCU design resources, MSP430Ware software also includes a high-level API called MSP Driver Library. This library makes it easy to program MSP430 hardware. MSP430Ware software is available as a component of CCS or as a stand-alone package.

[MSP430FR599x, MSP430FR596x Code Examples](#)

C code examples are available for every MSP device that configures each of the integrated peripherals for various application needs.

[Capacitive Touch Software Library](#)

Free C libraries for enabling capacitive touch capabilities on MSP430 MCUs. The library features several capacitive touch implementations including the RO and RC method. In addition to the full C code libraries, hardware design considerations are also provided as a simple guide for including capacitive touch into any MSP430 MCU-based application.

[MSP EnergyTrace Technology](#)

EnergyTrace technology for MSP430 microcontrollers is an energy-based code analysis tool that measures and displays the application's energy profile and helps to optimize it for ultra-low-power consumption.

[MSP Driver Library](#)

Driver Library's abstracted API keeps you above the bits and bytes of the MSP430 hardware by providing easy-to-use function calls. Thorough documentation is delivered through a helpful API Guide, which includes details on each function call and the recognized parameters. Developers can use Driver Library functions to write complete projects with minimal overhead.

[Digital Signal Processing Library](#)

The Texas Instruments Digital Signal Processing library is a set of highly optimized functions to perform many common signal processing operations on fixed-point numbers for MSP430™ and MSP432™ microcontrollers. This function set is typically used for applications where processing-intensive transforms are done in real-time for minimal energy and with very high accuracy. This library's optimal utilization of the MSP families' intrinsic hardware for fixed-point math allows for significant performance gains.

[FRAM Embedded Software Utilities for MSP Ultra-Low-Power Microcontrollers](#)

The FRAM Utilities is designed to grow as a collection of embedded software utilities that leverage the ultra-low-power and virtually unlimited write endurance of FRAM. The utilities are available for MSP430FRxx FRAM microcontrollers and provide example code to help start application development. Included utilities include Compute Through Power Loss (CTPL). CTPL is utility API set that enables ease of use with LPMx.5 low-power modes and a powerful shutdown mode that allows an application to save and restore critical system components when a power loss is detected.

Development Tools

[Code Composer Studio Integrated Development Environment for MSP Microcontrollers](#)

Code Composer Studio is an integrated development environment (IDE) that supports all MSP microcontroller devices. Code Composer Studio comprises a suite of embedded software utilities used to develop and debug embedded applications. It includes an optimizing C/C++ compiler, source code editor, project build environment, debugger, profiler, and many other features.

[Uniflash Standalone Flash Tool for TI Microcontrollers](#)

CCS Uniflash is a stand-alone tool used to program on-chip flash memory on TI MCUs and on-board flash memory for Sitara processors. Uniflash has a GUI, command line, and scripting interface. CCS Uniflash is available free of charge.

[MSP MCU Programmer and Debugger](#)

The MSP-FET is a powerful emulation development tool – often called a debug probe – that allows users to quickly begin application development on MSP low-power microcontrollers (MCU). Creating MCU software usually requires downloading the resulting binary program to the MSP device for validation and debugging. The MSP-FET provides a debug communication pathway between a host computer and the target MSP.

MSP-GANG Production Programmer

The MSP Gang Programmer is an MSP430 or MSP432 device programmer that can program up to eight identical MSP430 or MSP432 Flash or FRAM devices at the same time. The MSP Gang Programmer connects to a host PC using a standard RS-232 or USB connection and provides flexible programming options that allow the user to fully customize the process. The MSP Gang Programmer is provided with an expansion board, called the Gang Splitter, that implements the interconnections between the MSP Gang Programmer and multiple target devices.

11.4 Documentation Support

The following documents describe the MSP430FR599x and MSP430FR596x MCUs. Copies of these documents are available on the Internet at www.ti.com.

Receiving notification of document updates

To receive notification of documentation updates—including silicon errata—go to the product folder for your device on ti.com (for links to the product folders, see [Section 11.5](#)). In the upper right corner, click the "Alert me" button. This registers you to receive a weekly digest of product information that has changed (if any). For change details, check the revision history of any revised document.

Errata

[MSP430FR5994 Device Erratasheet](#)

Describes the known exceptions to the functional specifications.

[MSP430FR59941 Device Erratasheet](#)

Describes the known exceptions to the functional specifications.

[MSP430FR5992 Device Erratasheet](#)

Describes the known exceptions to the functional specifications.

[MSP430FR5964 Device Erratasheet](#)

Describes the known exceptions to the functional specifications.

[MSP430FR5962 Device Erratasheet](#)

Describes the known exceptions to the functional specifications.

User's Guides

[MSP430FR58xx, MSP430FR59xx, and MSP430FR6xx Family User's Guide](#)

Detailed description of all modules and peripherals available in this device family.

[MSP430 FRAM Device Bootloader \(BSL\) User's Guide](#)

The bootloader (BSL) on MSP430 MCUs lets users communicate with embedded memory in the MSP430 MCU during the prototyping phase, final production, and in service. Both the programmable memory (FRAM) and the data memory (RAM) can be modified as required.

[MSP430 Programming With the JTAG Interface](#)

This document describes the functions that are required to erase, program, and verify the memory module of the MSP430 flash-based and FRAM-based microcontroller families using the JTAG communication port. In addition, it describes how to program the JTAG access security fuse that is available on all MSP430 devices. This document describes device access using both the standard 4-wire JTAG interface and the 2-wire JTAG interface, which is also referred to as Spy-Bi-Wire (SBW).

MSP430 Hardware Tools User's Guide

This manual describes the hardware of the TI MSP-FET430 Flash Emulation Tool (FET). The FET is the program development tool for the MSP430 ultra-low-power microcontroller. Both available interface types, the parallel port interface and the USB interface, are described.

Application Reports

MSP430 32-kHz Crystal Oscillators

Selection of the right crystal, correct load circuit, and proper board layout are important for a stable crystal oscillator. This application report summarizes crystal oscillator function and explains the parameters to select the correct crystal for MSP430 ultra-low-power operation. In addition, hints and examples for correct board layout are given. The document also contains detailed information on the possible oscillator tests to ensure stable oscillator operation in mass production.

MSP430 System-Level ESD Considerations

System-level ESD has become increasingly demanding with silicon technology scaling towards lower voltages and the need for designing cost-effective and ultra-low-power components. This application report addresses three different ESD topics to help board designers and OEMs understand and design robust system-level designs: (1) Component-level ESD testing and system-level ESD testing; (2) General design guidelines for system-level ESD protection at different levels; (3) Introduction to System Efficient ESD Design (SEED).

MSP430™ FRAM Technology – How To and Best Practices

FRAM is a nonvolatile memory technology that behaves similar to SRAM while enabling a whole host of new applications, but also changing the way firmware should be designed. This application report outlines the how to and best practices of using FRAM technology in MSP430 MCUs from an embedded software development perspective. It discusses how to implement a memory layout according to application-specific code, constant, data space requirements, the use of FRAM to optimize application energy consumption, and the use of the Memory Protection Unit (MPU) to maximize application robustness by protecting the program code against unintended write accesses.

11.5 Related Links

Table 11-2 lists quick access links. Categories include technical documents, support and community resources, tools and software, and quick access to sample or buy.

Table 11-2. Related Links

PARTS	PRODUCT FOLDER	ORDER NOW	TECHNICAL DOCUMENTS	TOOLS & SOFTWARE	SUPPORT & COMMUNITY
MSP430FR5994	Click here	Click here	Click here	Click here	Click here
MSP430FR59941	Click here	Click here	Click here	Click here	Click here
MSP430FR5992	Click here	Click here	Click here	Click here	Click here
MSP430FR5964	Click here	Click here	Click here	Click here	Click here
MSP430FR5962	Click here	Click here	Click here	Click here	Click here

11.6 Support Resources

TI E2E™ [support forums](#) are an engineer's go-to source for fast, verified answers and design help — straight from the experts. Search existing answers or ask your own question to get the quick design help you need.

Linked content is provided "AS IS" by the respective contributors. They do not constitute TI specifications and do not necessarily reflect TI's views; see TI's [Terms of Use](#).

11.7 Trademarks

LaunchPad™, MSP430Ware™, MSP430™, Code Composer Studio™, EnergyTrace™, MSP432™, and TI E2E™ are trademarks of Texas Instruments.

Arm® and Cortex® are registered trademarks of Arm Limited.

All trademarks are the property of their respective owners.

11.8 Electrostatic Discharge Caution



This integrated circuit can be damaged by ESD. Texas Instruments recommends that all integrated circuits be handled with appropriate precautions. Failure to observe proper handling and installation procedures can cause damage.

ESD damage can range from subtle performance degradation to complete device failure. Precision integrated circuits may be more susceptible to damage because very small parametric changes could cause the device not to meet its published specifications.

11.9 Export Control Notice

Recipient agrees to not knowingly export or re-export, directly or indirectly, any product or technical data (as defined by the U.S., EU, and other Export Administration Regulations) including software, or any controlled product restricted by other applicable national regulations, received from disclosing party under nondisclosure obligations (if any), or any direct product of such technology, to any destination to which such export or re-export is restricted or prohibited by U.S. or other applicable laws, without obtaining prior authorization from U.S. Department of Commerce and other competent Government authorities to the extent required by those laws.

11.10 Glossary

TI Glossary This glossary lists and explains terms, acronyms, and definitions.

12 Mechanical, Packaging, and Orderable Information

The following pages include mechanical, packaging, and orderable information. This information is the most current data available for the designated devices. This data is subject to change without notice and revision of this document. For browser-based versions of this data sheet, refer to the left-hand navigation.

PACKAGING INFORMATION

Orderable Device	Status (1)	Package Type	Package Drawing	Pins	Package Qty	Eco Plan (2)	Lead finish/ Ball material (6)	MSL Peak Temp (3)	Op Temp (°C)	Device Marking (4/5)	Samples
MSP430FR5962IPMR	ACTIVE	LQFP	PM	64	1000	RoHS & Green	NIPDAU	Level-3-260C-168 HR	-40 to 85	FR5962	Samples
MSP430FR5962IPNR	ACTIVE	LQFP	PN	80	1000	RoHS & Green	NIPDAU	Level-3-260C-168 HR	-40 to 85	FR5962	Samples
MSP430FR5962IRGZR	ACTIVE	VQFN	RGZ	48	2500	RoHS & Green	NIPDAU	Level-3-260C-168 HR	-40 to 85	FR5962	Samples
MSP430FR5962IZVWR	ACTIVE	NFBGA	ZVW	87	1000	RoHS & Green	SNAGCU	Level-3-260C-168 HR	-40 to 85	FR5962	Samples
MSP430FR5964IPMR	ACTIVE	LQFP	PM	64	1000	RoHS & Green	NIPDAU	Level-3-260C-168 HR	-40 to 85	FR5964	Samples
MSP430FR5964IPNR	ACTIVE	LQFP	PN	80	1000	RoHS & Green	NIPDAU	Level-3-260C-168 HR	-40 to 85	FR5964	Samples
MSP430FR5964IRGZR	ACTIVE	VQFN	RGZ	48	2500	RoHS & Green	NIPDAU	Level-3-260C-168 HR	-40 to 85	FR5964	Samples
MSP430FR5964IZVWR	ACTIVE	NFBGA	ZVW	87	1000	RoHS & Green	SNAGCU	Level-3-260C-168 HR	-40 to 85	FR5964	Samples
MSP430FR5992IPMR	ACTIVE	LQFP	PM	64	1000	RoHS & Green	NIPDAU	Level-3-260C-168 HR	-40 to 85	FR5992	Samples
MSP430FR5992IPNR	ACTIVE	LQFP	PN	80	1000	RoHS & Green	NIPDAU	Level-3-260C-168 HR	-40 to 85	FR5992	Samples
MSP430FR5992IRGZR	ACTIVE	VQFN	RGZ	48	2500	RoHS & Green	NIPDAU	Level-3-260C-168 HR	-40 to 85	FR5992	Samples
MSP430FR5992IZVWR	ACTIVE	NFBGA	ZVW	87	1000	RoHS & Green	SNAGCU	Level-3-260C-168 HR	-40 to 85	FR5992	Samples
MSP430FR59941IPM	ACTIVE	LQFP	PM	64	160	RoHS & Green	NIPDAU	Level-3-260C-168 HR	-40 to 85	FR59941	Samples
MSP430FR59941IPMR	ACTIVE	LQFP	PM	64	1000	RoHS & Green	NIPDAU	Level-3-260C-168 HR	-40 to 85	FR59941	Samples
MSP430FR59941IPN	ACTIVE	LQFP	PN	80	119	RoHS & Green	NIPDAU	Level-3-260C-168 HR	-40 to 85	FR59941	Samples
MSP430FR59941IPNR	ACTIVE	LQFP	PN	80	1000	RoHS & Green	NIPDAU	Level-3-260C-168 HR	-40 to 85	FR59941	Samples
MSP430FR59941IRGZR	ACTIVE	VQFN	RGZ	48	2500	RoHS & Green	NIPDAU	Level-3-260C-168 HR	-40 to 85	FR59941	Samples
MSP430FR59941IRGZT	ACTIVE	VQFN	RGZ	48	250	RoHS & Green	NIPDAU	Level-3-260C-168 HR	-40 to 85	FR59941	Samples
MSP430FR59941IZVW	ACTIVE	NFBGA	ZVW	87	250	RoHS & Green	SNAGCU	Level-3-260C-168 HR	-40 to 85	FR59941	Samples
MSP430FR59941IZVWR	ACTIVE	NFBGA	ZVW	87	1000	RoHS & Green	SNAGCU	Level-3-260C-168 HR	-40 to 85	FR59941	Samples

Orderable Device	Status (1)	Package Type	Package Drawing	Pins	Package Qty	Eco Plan (2)	Lead finish/ Ball material (6)	MSL Peak Temp (3)	Op Temp (°C)	Device Marking (4/5)	Samples
MSP430FR5994IPM	ACTIVE	LQFP	PM	64	160	RoHS & Green	NIPDAU	Level-3-260C-168 HR	-40 to 85	FR5994	Samples
MSP430FR5994IPMR	ACTIVE	LQFP	PM	64	1000	RoHS & Green	NIPDAU	Level-3-260C-168 HR	-40 to 85	FR5994	Samples
MSP430FR5994IPN	ACTIVE	LQFP	PN	80	119	RoHS & Green	NIPDAU	Level-3-260C-168 HR	-40 to 85	FR5994	Samples
MSP430FR5994IPNR	ACTIVE	LQFP	PN	80	1000	RoHS & Green	NIPDAU	Level-3-260C-168 HR	-40 to 85	FR5994	Samples
MSP430FR5994IRGZR	ACTIVE	VQFN	RGZ	48	2500	RoHS & Green	NIPDAU	Level-3-260C-168 HR	-40 to 85	FR5994	Samples
MSP430FR5994IRGZT	ACTIVE	VQFN	RGZ	48	250	RoHS & Green	NIPDAU	Level-3-260C-168 HR	-40 to 85	FR5994	Samples
MSP430FR5994IZVW	ACTIVE	NFBGA	ZVW	87	250	RoHS & Green	SNAGCU	Level-3-260C-168 HR	-40 to 85	FR5994	Samples
MSP430FR5994IZVWR	ACTIVE	NFBGA	ZVW	87	1000	RoHS & Green	SNAGCU	Level-3-260C-168 HR	-40 to 85	FR5994	Samples

(1) The marketing status values are defined as follows:

ACTIVE: Product device recommended for new designs.

LIFEBUY: TI has announced that the device will be discontinued, and a lifetime-buy period is in effect.

NRND: Not recommended for new designs. Device is in production to support existing customers, but TI does not recommend using this part in a new design.

PREVIEW: Device has been announced but is not in production. Samples may or may not be available.

OBSOLETE: TI has discontinued the production of the device.

(2) **RoHS:** TI defines "RoHS" to mean semiconductor products that are compliant with the current EU RoHS requirements for all 10 RoHS substances, including the requirement that RoHS substance do not exceed 0.1% by weight in homogeneous materials. Where designed to be soldered at high temperatures, "RoHS" products are suitable for use in specified lead-free processes. TI may reference these types of products as "Pb-Free".

RoHS Exempt: TI defines "RoHS Exempt" to mean products that contain lead but are compliant with EU RoHS pursuant to a specific EU RoHS exemption.

Green: TI defines "Green" to mean the content of Chlorine (Cl) and Bromine (Br) based flame retardants meet JS709B low halogen requirements of <=1000ppm threshold. Antimony trioxide based flame retardants must also meet the <=1000ppm threshold requirement.

(3) MSL, Peak Temp. - The Moisture Sensitivity Level rating according to the JEDEC industry standard classifications, and peak solder temperature.

(4) There may be additional marking, which relates to the logo, the lot trace code information, or the environmental category on the device.

(5) Multiple Device Markings will be inside parentheses. Only one Device Marking contained in parentheses and separated by a "~" will appear on a device. If a line is indented then it is a continuation of the previous line and the two combined represent the entire Device Marking for that device.

⁽⁶⁾ Lead finish/Ball material - Orderable Devices may have multiple material finish options. Finish options are separated by a vertical ruled line. Lead finish/Ball material values may wrap to two lines if the finish value exceeds the maximum column width.

Important Information and Disclaimer:The information provided on this page represents TI's knowledge and belief as of the date that it is provided. TI bases its knowledge and belief on information provided by third parties, and makes no representation or warranty as to the accuracy of such information. Efforts are underway to better integrate information from third parties. TI has taken and continues to take reasonable steps to provide representative and accurate information but may not have conducted destructive testing or chemical analysis on incoming materials and chemicals. TI and TI suppliers consider certain information to be proprietary, and thus CAS numbers and other limited information may not be available for release.

In no event shall TI's liability arising out of such information exceed the total purchase price of the TI part(s) at issue in this document sold by TI to Customer on an annual basis.

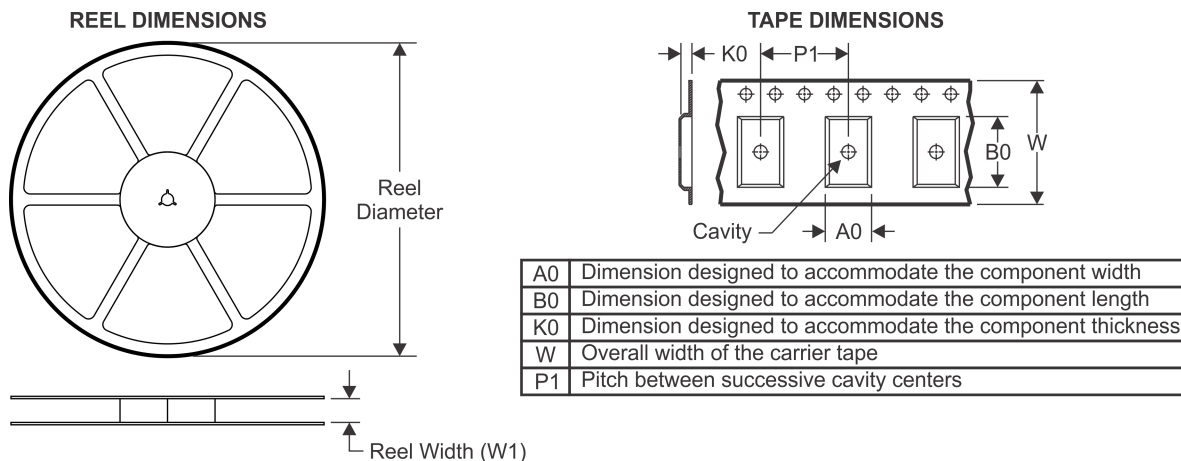
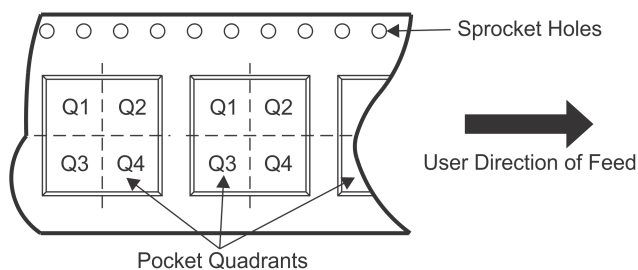
TAPE AND REEL INFORMATION

QUADRANT ASSIGNMENTS FOR PIN 1 ORIENTATION IN TAPE

*All dimensions are nominal

Device	Package Type	Package Drawing	Pins	SPQ	Reel Diameter (mm)	Reel Width W1 (mm)	A0 (mm)	B0 (mm)	K0 (mm)	P1 (mm)	W (mm)	Pin1 Quadrant
MSP430FR5962IPMR	LQFP	PM	64	1000	330.0	24.4	13.0	13.0	2.1	16.0	24.0	Q2
MSP430FR5962IPNR	LQFP	PN	80	1000	330.0	24.4	16.0	16.0	2.0	24.0	24.0	Q2
MSP430FR5962IRGZR	VQFN	RGZ	48	2500	330.0	16.4	7.3	7.3	1.1	12.0	16.0	Q2
MSP430FR5962IZVWR	NFBGA	ZVW	87	1000	330.0	16.4	6.3	6.3	1.5	12.0	16.0	Q1
MSP430FR5964IPMR	LQFP	PM	64	1000	330.0	24.4	13.0	13.0	2.1	16.0	24.0	Q2
MSP430FR5964IPNR	LQFP	PN	80	1000	330.0	24.4	16.0	16.0	2.0	24.0	24.0	Q2
MSP430FR5964IRGZR	VQFN	RGZ	48	2500	330.0	16.4	7.3	7.3	1.1	12.0	16.0	Q2
MSP430FR5964IZVWR	NFBGA	ZVW	87	1000	330.0	16.4	6.3	6.3	1.5	12.0	16.0	Q1
MSP430FR5992IPMR	LQFP	PM	64	1000	330.0	24.4	13.0	13.0	2.1	16.0	24.0	Q2
MSP430FR5992IPNR	LQFP	PN	80	1000	330.0	24.4	16.0	16.0	2.0	24.0	24.0	Q2
MSP430FR5992IRGZR	VQFN	RGZ	48	2500	330.0	16.4	7.3	7.3	1.1	12.0	16.0	Q2
MSP430FR5992IZVWR	NFBGA	ZVW	87	1000	330.0	16.4	6.3	6.3	1.5	12.0	16.0	Q1
MSP430FR59941IPMR	LQFP	PM	64	1000	330.0	24.4	13.0	13.0	2.1	16.0	24.0	Q2
MSP430FR59941IPNR	LQFP	PN	80	1000	330.0	24.4	16.0	16.0	2.0	24.0	24.0	Q2
MSP430FR59941IRGZR	VQFN	RGZ	48	2500	330.0	16.4	7.3	7.3	1.1	12.0	16.0	Q2
MSP430FR59941IRGZT	VQFN	RGZ	48	250	180.0	16.4	7.3	7.3	1.1	12.0	16.0	Q2
MSP430FR59941IZVWR	NFBGA	ZVW	87	1000	330.0	16.4	6.3	6.3	1.5	12.0	16.0	Q1
MSP430FR5994IPMR	LQFP	PM	64	1000	330.0	24.4	13.0	13.0	2.1	16.0	24.0	Q2

Device	Package Type	Package Drawing	Pins	SPQ	Reel Diameter (mm)	Reel Width W1 (mm)	A0 (mm)	B0 (mm)	K0 (mm)	P1 (mm)	W (mm)	Pin1 Quadrant
MSP430FR5994IPNR	LQFP	PN	80	1000	330.0	24.4	16.0	16.0	2.0	24.0	24.0	Q2
MSP430FR5994IRGZR	VQFN	RGZ	48	2500	330.0	16.4	7.3	7.3	1.1	12.0	16.0	Q2
MSP430FR5994IRGZT	VQFN	RGZ	48	250	180.0	16.4	7.3	7.3	1.1	12.0	16.0	Q2
MSP430FR5994IZVWR	NFBGA	ZVW	87	1000	330.0	16.4	6.3	6.3	1.5	12.0	16.0	Q1

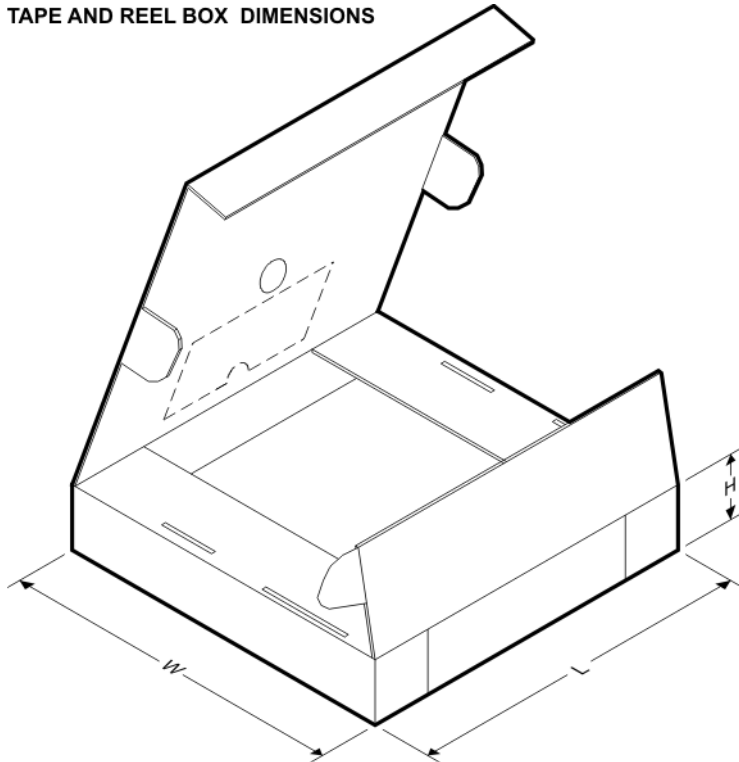
TAPE AND REEL BOX DIMENSIONS



*All dimensions are nominal

Device	Package Type	Package Drawing	Pins	SPQ	Length (mm)	Width (mm)	Height (mm)
MSP430FR5962IPMR	LQFP	PM	64	1000	336.6	336.6	41.3
MSP430FR5962IPNR	LQFP	PN	80	1000	367.0	367.0	55.0
MSP430FR5962IRGZR	VQFN	RGZ	48	2500	367.0	367.0	38.0
MSP430FR5962IZVWR	NFBGA	ZVW	87	1000	336.6	336.6	31.8
MSP430FR5964IPMR	LQFP	PM	64	1000	336.6	336.6	41.3
MSP430FR5964IPNR	LQFP	PN	80	1000	367.0	367.0	55.0
MSP430FR5964IRGZR	VQFN	RGZ	48	2500	367.0	367.0	38.0
MSP430FR5964IZVWR	NFBGA	ZVW	87	1000	336.6	336.6	31.8
MSP430FR5992IPMR	LQFP	PM	64	1000	336.6	336.6	41.3
MSP430FR5992IPNR	LQFP	PN	80	1000	367.0	367.0	55.0
MSP430FR5992IRGZR	VQFN	RGZ	48	2500	367.0	367.0	38.0
MSP430FR5992IZVWR	NFBGA	ZVW	87	1000	336.6	336.6	31.8
MSP430FR59941IPMR	LQFP	PM	64	1000	336.6	336.6	41.3

Device	Package Type	Package Drawing	Pins	SPQ	Length (mm)	Width (mm)	Height (mm)
MSP430FR59941IPNR	LQFP	PN	80	1000	367.0	367.0	55.0
MSP430FR59941IRGZR	VQFN	RGZ	48	2500	367.0	367.0	38.0
MSP430FR59941IRGZT	VQFN	RGZ	48	250	210.0	185.0	35.0
MSP430FR59941IZVWR	NFBGA	ZVW	87	1000	336.6	336.6	31.8
MSP430FR5994IPMR	LQFP	PM	64	1000	336.6	336.6	41.3
MSP430FR5994IPNR	LQFP	PN	80	1000	367.0	367.0	55.0
MSP430FR5994IRGZR	VQFN	RGZ	48	2500	367.0	367.0	38.0
MSP430FR5994IRGZT	VQFN	RGZ	48	250	210.0	185.0	35.0
MSP430FR5994IZVWR	NFBGA	ZVW	87	1000	336.6	336.6	31.8

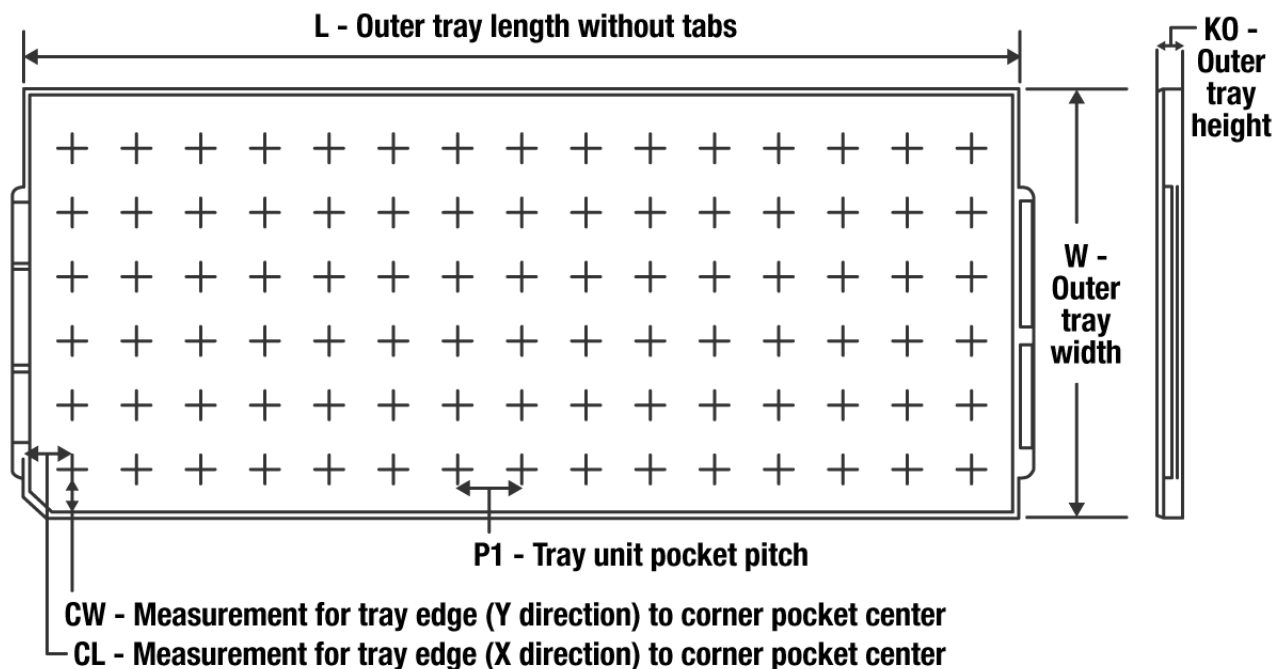
TRAY

Chamfer on Tray corner indicates Pin 1 orientation of packed units.

*All dimensions are nominal

Device	Package Name	Package Type	Pins	SPQ	Unit array matrix	Max temperature (°C)	L (mm)	W (mm)	K0 (µm)	P1 (mm)	CL (mm)	CW (mm)
MSP430FR59941IZVW	ZVW	NFBGA	87	250	10 x 25	150	315	135.9	7620	12.4	8.7	9
MSP430FR5994IZVW	ZVW	NFBGA	87	250	10 x 25	150	315	135.9	7620	12.4	8.7	9

PM0064A

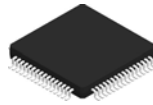

PACKAGE OUTLINE

LQFP - 1.6 mm max height

PLASTIC QUAD FLATPACK

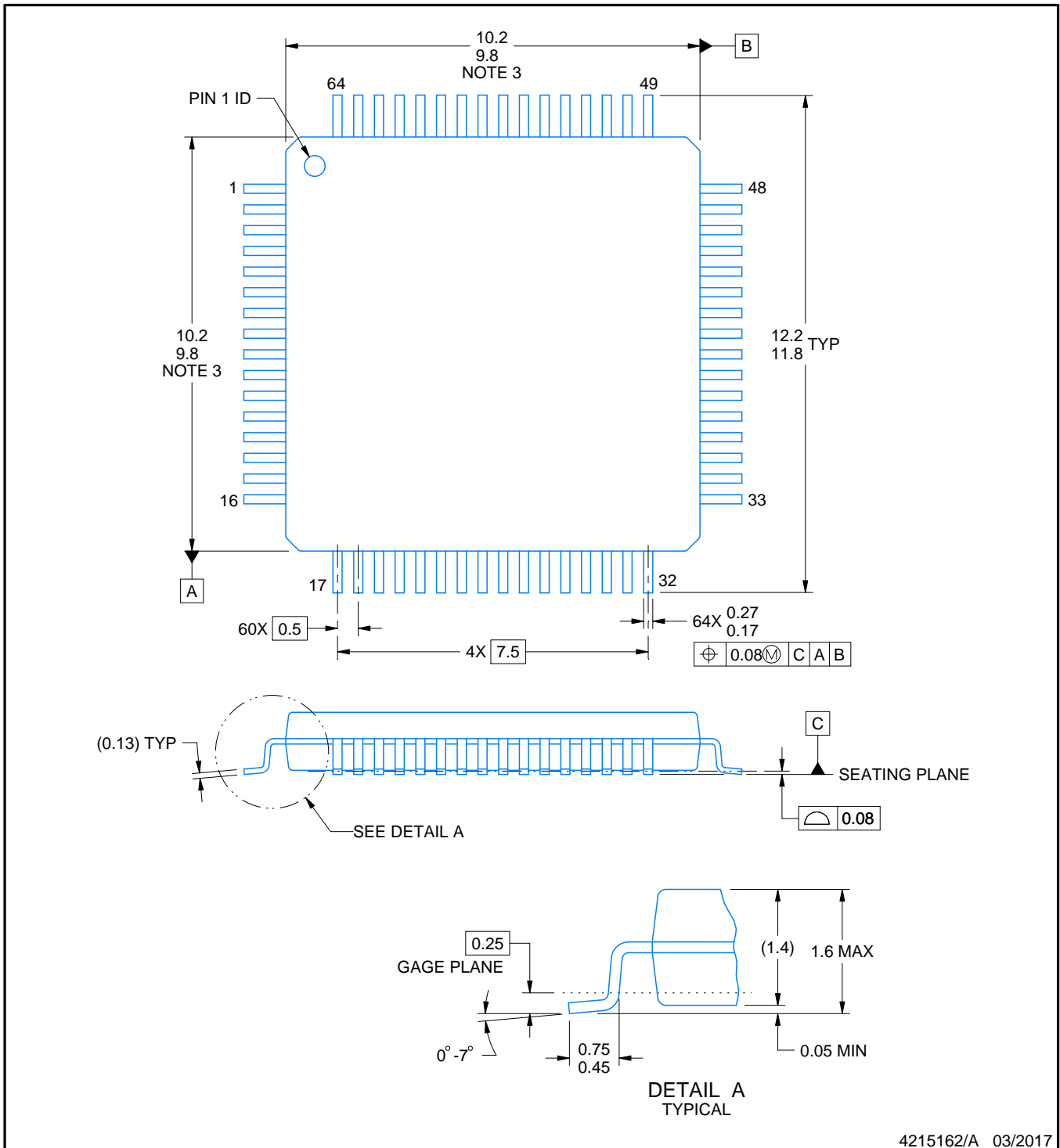

4215162/A 03/2017

NOTES:

1. All linear dimensions are in millimeters. Any dimensions in parenthesis are for reference only. Dimensioning and tolerancing per ASME Y14.5M.
2. This drawing is subject to change without notice.
3. This dimension does not include mold flash, protrusions, or gate burrs. Mold flash, protrusions, or gate burrs shall not exceed 0.15 mm per side.
4. Reference JEDEC registration MS-026.

EXAMPLE BOARD LAYOUT

PM0064A

LQFP - 1.6 mm max height

PLASTIC QUAD FLATPACK

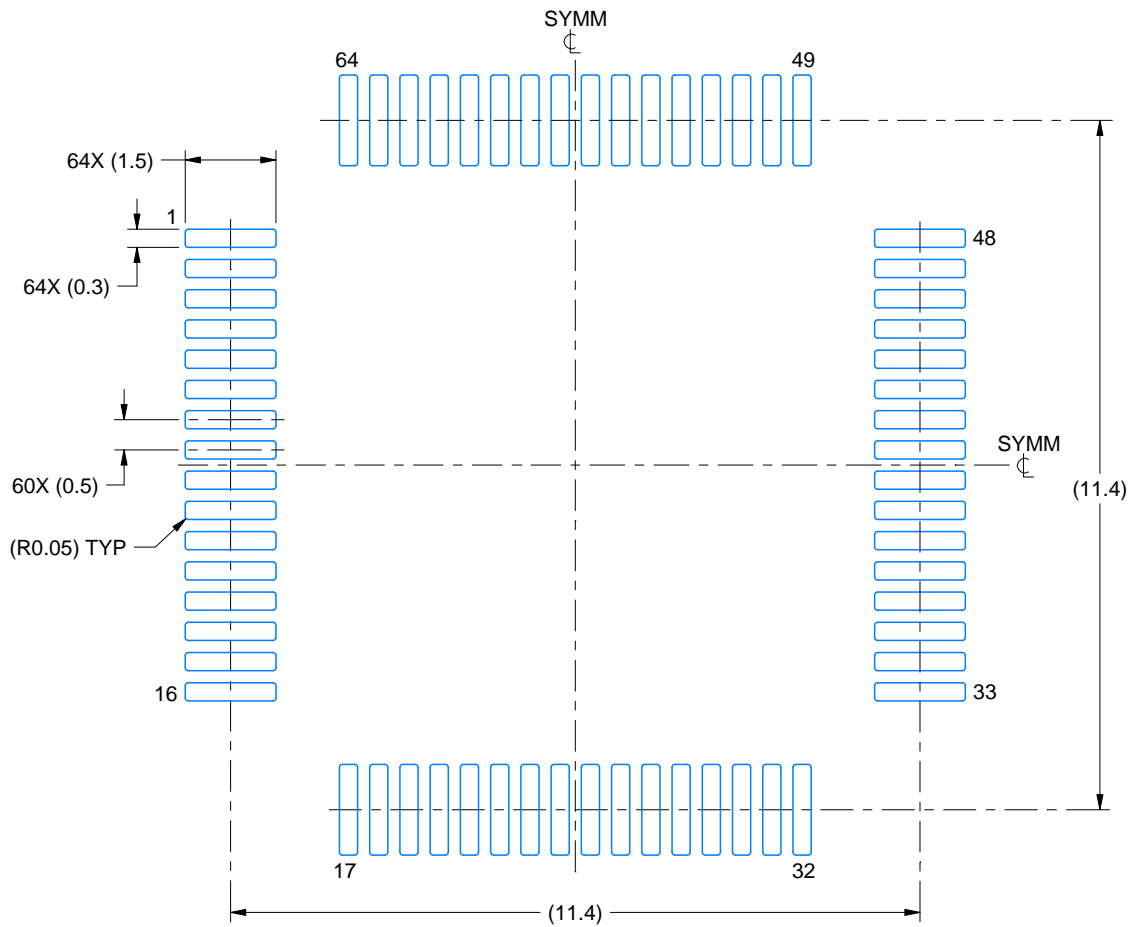

LAND PATTERN EXAMPLE
EXPOSED METAL SHOWN
SCALE:8X

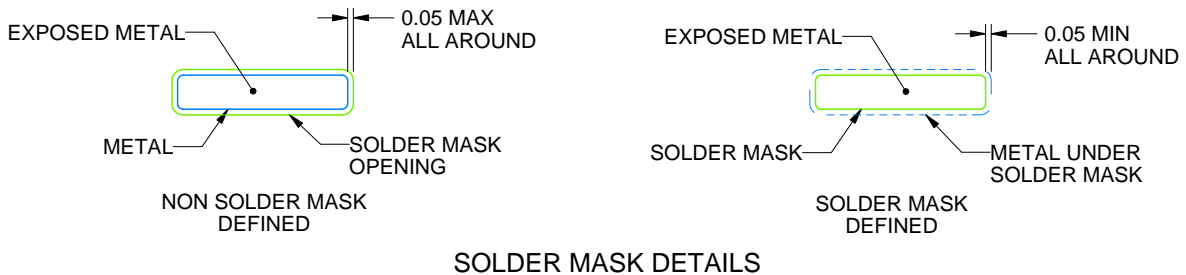

SOLDER MASK DETAILS

4215162/A 03/2017

NOTES: (continued)

5. Publication IPC-7351 may have alternate designs.
6. Solder mask tolerances between and around signal pads can vary based on board fabrication site.
7. For more information, see Texas Instruments literature number SLMA004 (www.ti.com/lit/slma004).

EXAMPLE STENCIL DESIGN

PM0064A

LQFP - 1.6 mm max height

PLASTIC QUAD FLATPACK

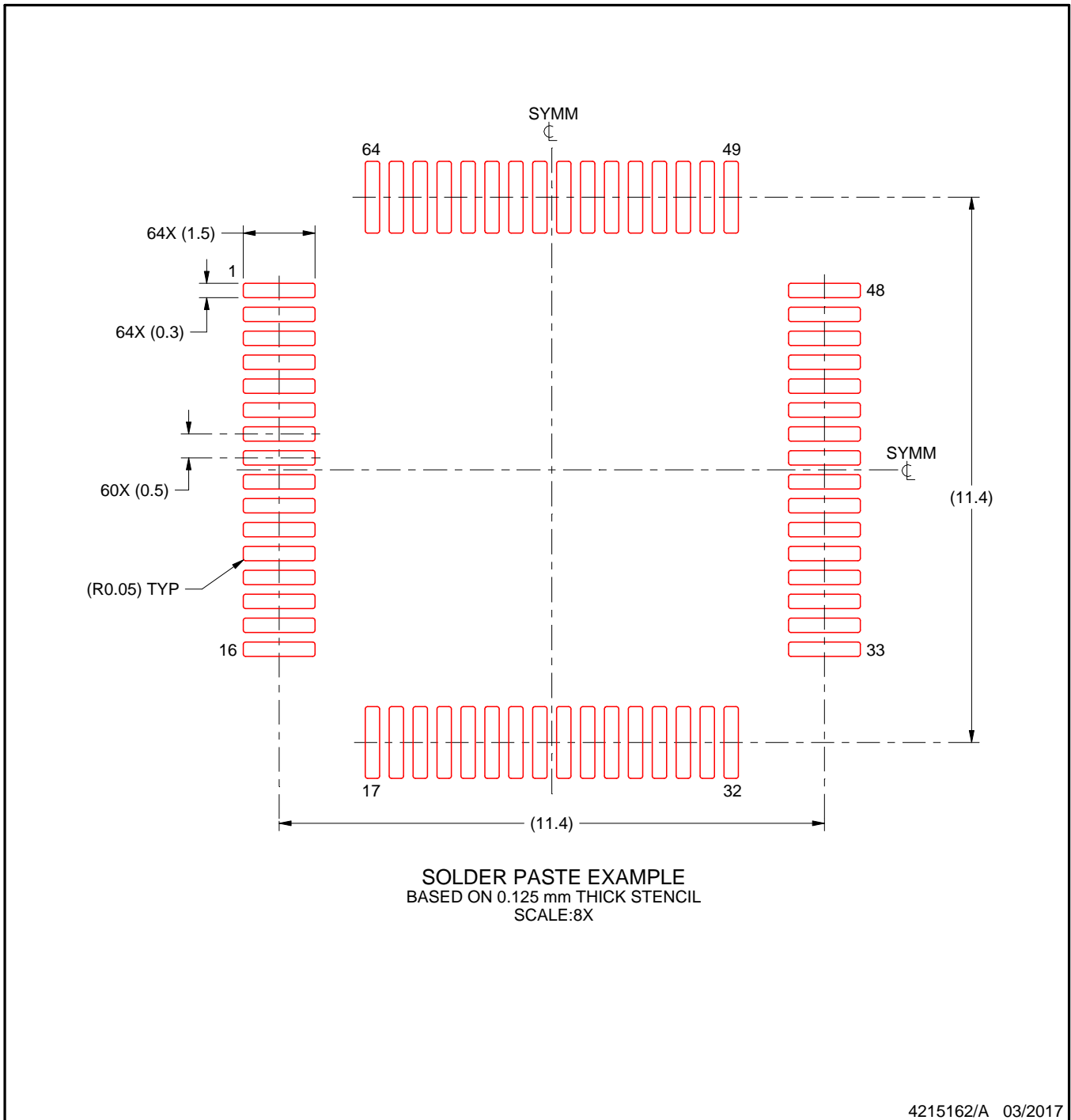

NOTES: (continued)

8. Laser cutting apertures with trapezoidal walls and rounded corners may offer better paste release. IPC-7525 may have alternate design recommendations.
9. Board assembly site may have different recommendations for stencil design.

GENERIC PACKAGE VIEW

RGZ 48

VQFN - 1 mm max height

7 x 7, 0.5 mm pitch

PLASTIC QUADFLAT PACK- NO LEAD

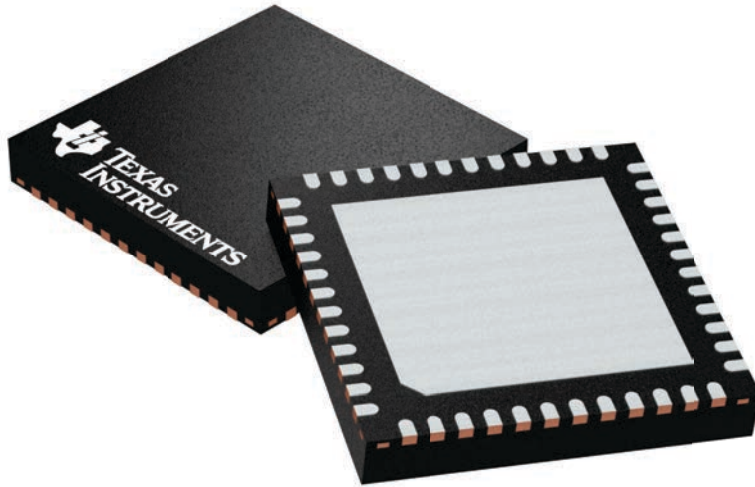

Images above are just a representation of the package family, actual package may vary.
Refer to the product data sheet for package details.

4224671/A

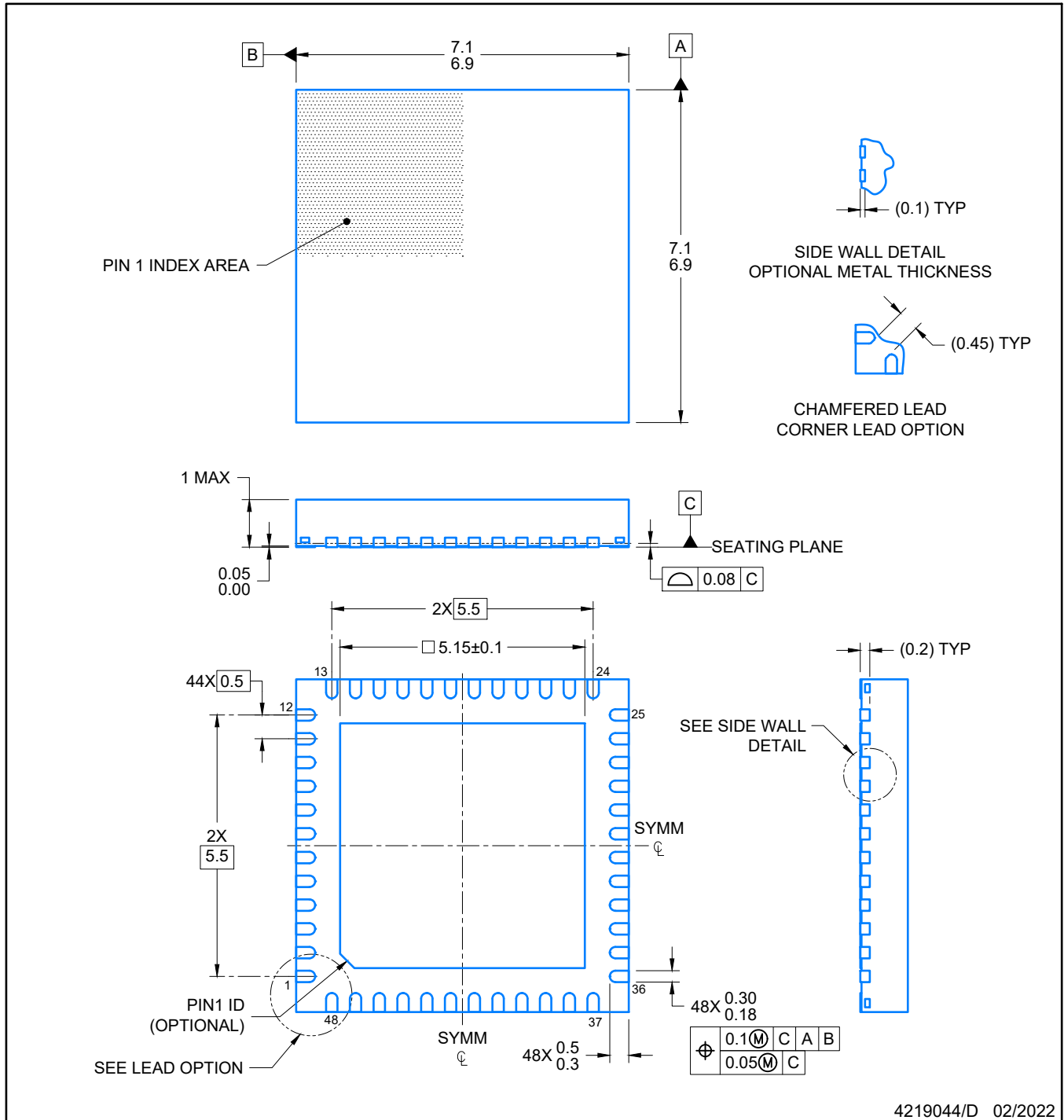

NOTES:

1. All linear dimensions are in millimeters. Any dimensions in parenthesis are for reference only. Dimensioning and tolerancing per ASME Y14.5M.
2. This drawing is subject to change without notice.
3. The package thermal pad must be soldered to the printed circuit board for optimal thermal and mechanical performance.

EXAMPLE BOARD LAYOUT

RGZ0048A

VQFN - 1 mm max height

PLASTIC QUADFLAT PACK- NO LEAD

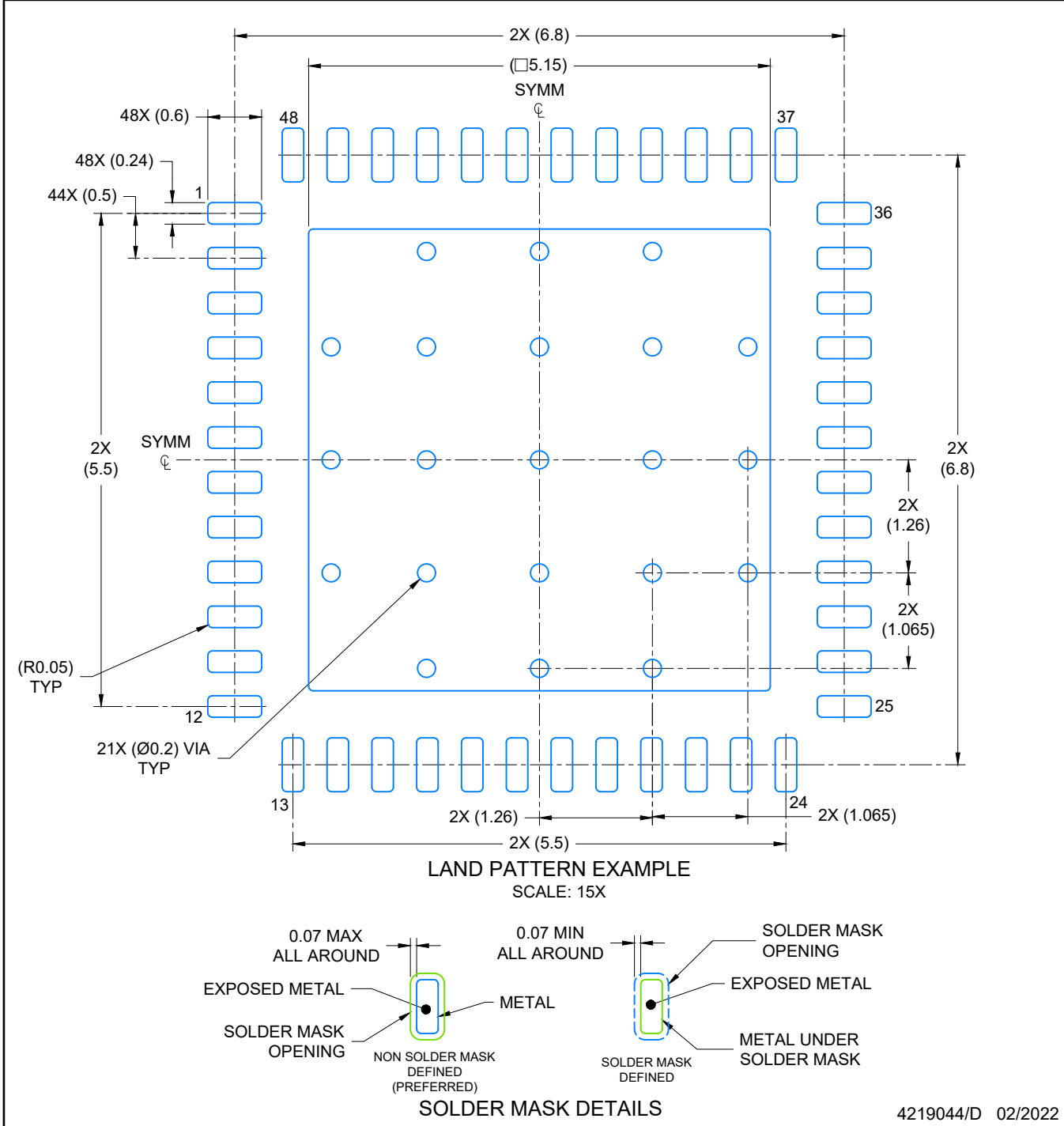

NOTES: (continued)

- 4. This package is designed to be soldered to a thermal pad on the board. For more information, see Texas Instruments literature number SLUA271 (www.ti.com/lit/slua271).
- 5. Vias are optional depending on application, refer to device data sheet. If any vias are implemented, refer to their locations shown on this view. It is recommended that vias under paste be filled, plugged or tented.

EXAMPLE STENCIL DESIGN

RGZ0048A

VQFN - 1 mm max height

PLASTIC QUADFLAT PACK- NO LEAD

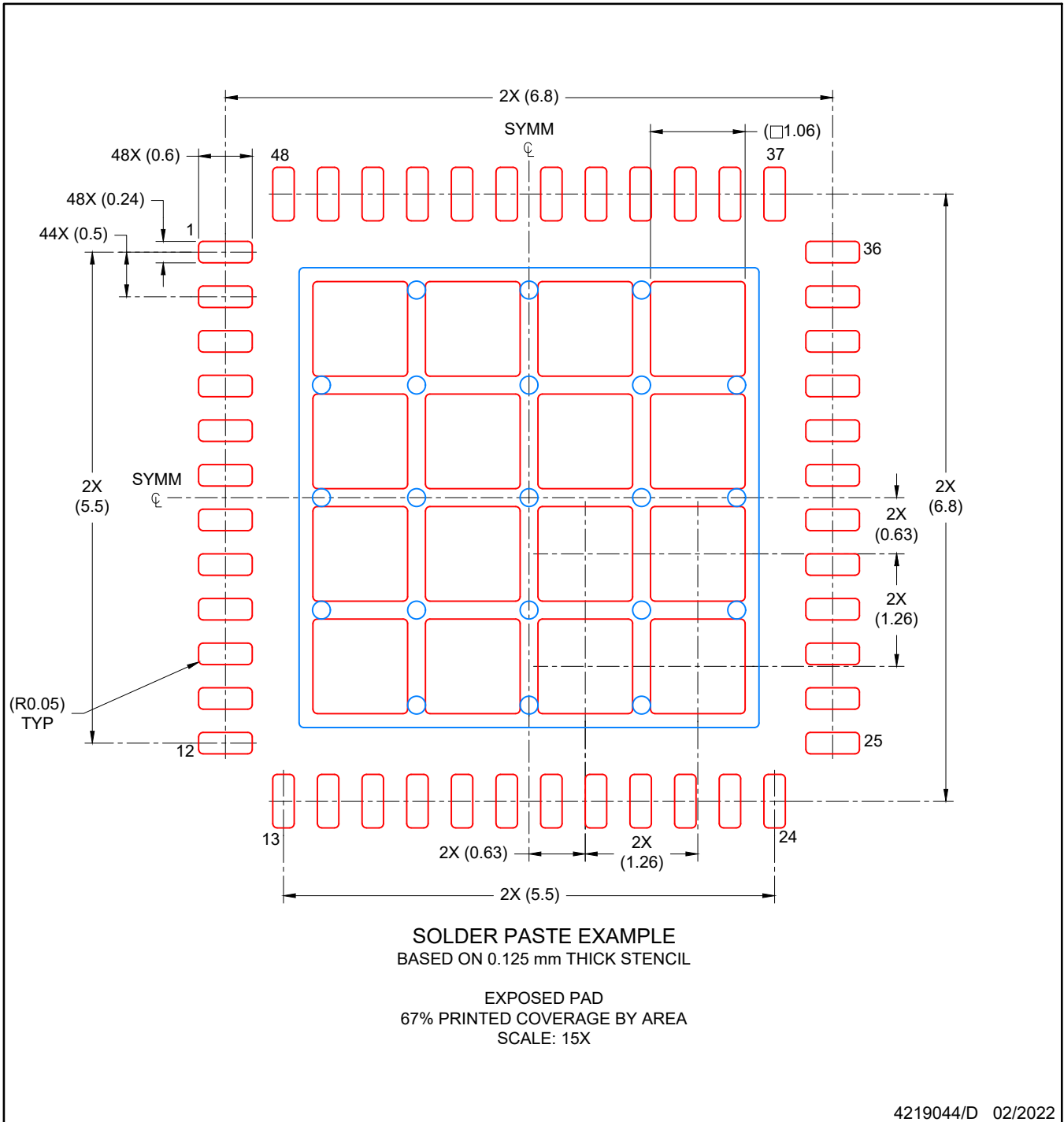

NOTES: (continued)

6. Laser cutting apertures with trapezoidal walls and rounded corners may offer better paste release. IPC-7525 may have alternate design recommendations.

PN (S-PQFP-G80)

PLASTIC QUAD FLATPACK

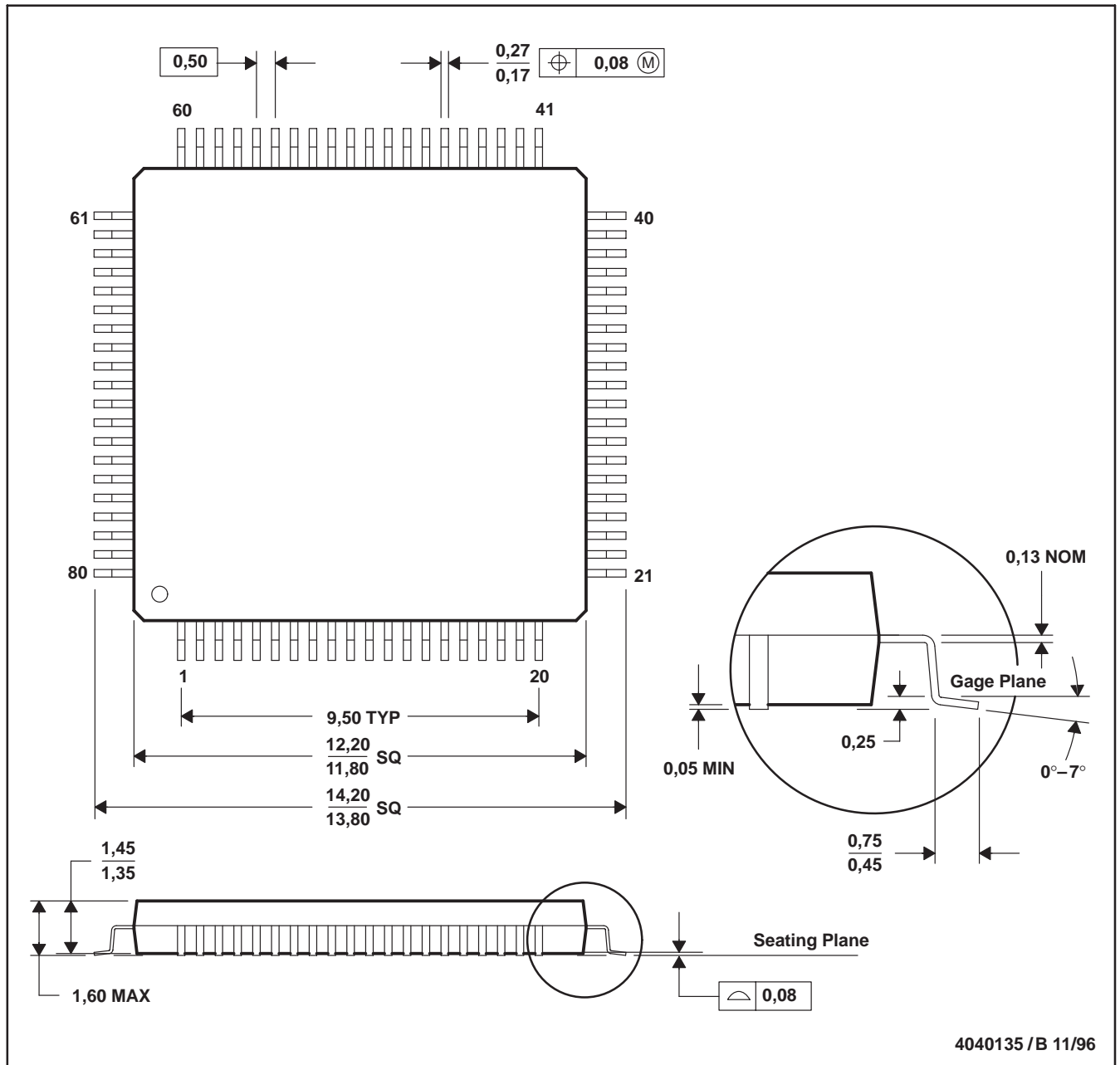

- NOTES: A. All linear dimensions are in millimeters.
 B. This drawing is subject to change without notice.
 C. Falls within JEDEC MS-026

MECHANICAL DATA

ZVW (S-PBGA-N87)

PLASTIC BALL GRID ARRAY

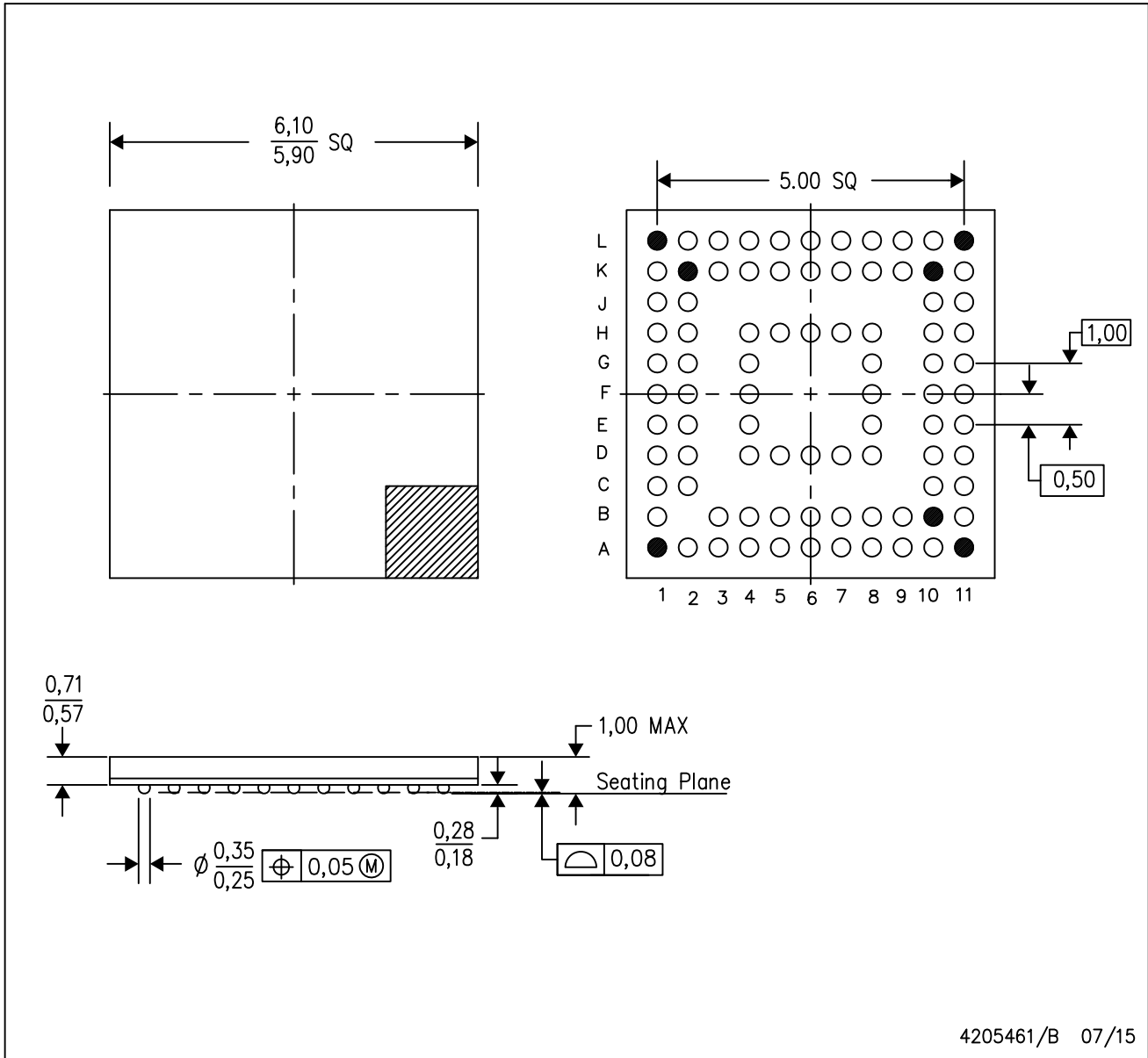

- NOTES:
- A. All linear dimensions are in millimeters.
 - B. This drawing is subject to change without notice.
 - C. nFBGA configuration.
 - D. A1, A11, L1, L11, B10, K2, K10 to be dummy balls.
 - E. This package is Pb-free.

IMPORTANT NOTICE AND DISCLAIMER

TI PROVIDES TECHNICAL AND RELIABILITY DATA (INCLUDING DATA SHEETS), DESIGN RESOURCES (INCLUDING REFERENCE DESIGNS), APPLICATION OR OTHER DESIGN ADVICE, WEB TOOLS, SAFETY INFORMATION, AND OTHER RESOURCES "AS IS" AND WITH ALL FAULTS, AND DISCLAIMS ALL WARRANTIES, EXPRESS AND IMPLIED, INCLUDING WITHOUT LIMITATION ANY IMPLIED WARRANTIES OF MERCHANTABILITY, FITNESS FOR A PARTICULAR PURPOSE OR NON-INFRINGEMENT OF THIRD PARTY INTELLECTUAL PROPERTY RIGHTS.

These resources are intended for skilled developers designing with TI products. You are solely responsible for (1) selecting the appropriate TI products for your application, (2) designing, validating and testing your application, and (3) ensuring your application meets applicable standards, and any other safety, security, regulatory or other requirements.

These resources are subject to change without notice. TI grants you permission to use these resources only for development of an application that uses the TI products described in the resource. Other reproduction and display of these resources is prohibited. No license is granted to any other TI intellectual property right or to any third party intellectual property right. TI disclaims responsibility for, and you will fully indemnify TI and its representatives against, any claims, damages, costs, losses, and liabilities arising out of your use of these resources.

TI's products are provided subject to [TI's Terms of Sale](#) or other applicable terms available either on ti.com or provided in conjunction with such TI products. TI's provision of these resources does not expand or otherwise alter TI's applicable warranties or warranty disclaimers for TI products.

TI objects to and rejects any additional or different terms you may have proposed.

Mailing Address: Texas Instruments, Post Office Box 655303, Dallas, Texas 75265
Copyright © 2022, Texas Instruments Incorporated