

## OPA1622 SoundPlus™ 高保真、双极输入音频运算放大器

### 1 特性

- 高保真音质
- 超低噪声：1kHz 时为  $2.8\text{nV}/\sqrt{\text{Hz}}$
- 超低总谐波失真 + 噪声 (THD+N)：-119dB (142mW/通道至 32Ω/通道)
- 宽增益带宽产品：32MHz (G = +1000)
- 高转换率：10V/μs
- 高容性负载驱动能力：> 600pF
- 高开环增益：136dB (600Ω 负载)
- 低静态电流：每通道 2.6mA
- 可降低喀哒和噼啪噪声的低功耗关断模式：每通道 5μA
- 短路保护
- 宽电源电压范围：±2V 至 ±18V
- 采用小型超薄小外形尺寸无引线 (VSON)-10 封装

### 2 应用

- 高保真 (HiFi) 耳机驱动器
- 专业音频设备
- 模数混合控制台
- 音频测试和测量
- 高端 蓝光碟™ 播放器
- 高端影音 (A/V) 接收器

### 3 说明

OPA1622 是一款双通道、双极输入、SoundPlus™ 音频运算放大器。该器件在 1kHz 频率下拥有  $2.8\text{nV}/\sqrt{\text{Hz}}$  的超低噪声密度和 -119.2dB 的超低 THD+N，同时还能够以 100mW 的输出功率驱动一个 32Ω 负载。OPA1622 具有极高的交流电源抑制比 (PSRR) 和共模抑制比 (CMRR) 技术规格，可消除来自电源的噪声，因此非常适合便携音频应用。此外，该器件还具有 +145mA/-130mA 的高输出驱动能力。

OPA1622 支持 ±2V 到 ±18V 的宽电源电压范围，每通道电源电流仅为 2.6mA。OPA1622 运算放大器的单位增益稳定，在宽范围负载条件下可保持出色的动态性能。OPA1622 具有关断模式，允许放大器从正常运行状态切换至一个待机电流典型值低于 5μA 的状态。此关断特性专门用于消除进入或退出关断模式时的喀哒和噼啪噪声。

OPA1622 内部采用独特布局，即使在过驱或过载条件下也可在通道间实现最低串扰和零交互。此器件的额定温度介于 -40°C 至 +125°C 之间。

器件信息(1)

器件型号	封装	封装尺寸 (标称值)
OPA1622	VSON (10)	3.00mm x 3.00mm

(1) 要了解所有可用封装，请参见数据表末尾的封装选项附录。

OPA1622 应用于高保真耳机驱动器

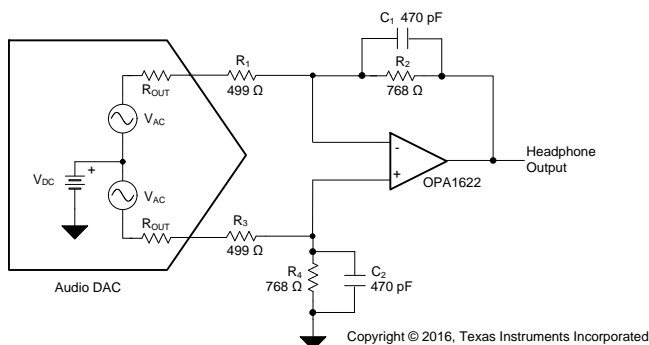

快速傅立叶变换 (FFT): 1kHz、32Ω 负载、50mW

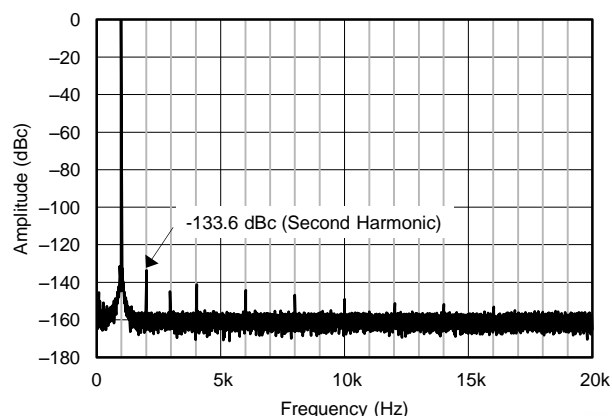

## 目录

<b>1</b>	特性 .....	<b>1</b>	7.4	Device Functional Modes.....	<b>17</b>
<b>2</b>	应用 .....	<b>1</b>	<b>8</b>	<b>Application and Implementation</b> .....	<b>19</b>
<b>3</b>	说明 .....	<b>1</b>	8.1	Application Information.....	<b>19</b>
<b>4</b>	修订历史记录 .....	<b>2</b>	8.2	Typical Application .....	<b>22</b>
<b>5</b>	<b>Pin Configuration and Functions</b> .....	<b>3</b>	<b>9</b>	<b>Power Supply Recommendations</b> .....	<b>26</b>
<b>6</b>	<b>Specifications</b> .....	<b>4</b>	<b>10</b>	<b>Layout</b> .....	<b>26</b>
6.1	Absolute Maximum Ratings .....	<b>4</b>	10.1	Layout Guidelines .....	<b>26</b>
6.2	ESD Ratings.....	<b>4</b>	10.2	Layout Example .....	<b>26</b>
6.3	Recommended Operating Conditions.....	<b>4</b>	<b>11</b>	器件和文档支持 .....	<b>27</b>
6.4	Thermal Information .....	<b>4</b>	11.1	器件支持 .....	<b>27</b>
6.5	Electrical Characteristics: .....	<b>5</b>	11.2	文档支持 .....	<b>27</b>
6.6	Typical Characteristics .....	<b>7</b>	11.3	社区资源 .....	<b>27</b>
<b>7</b>	<b>Detailed Description</b> .....	<b>14</b>	11.4	商标 .....	<b>27</b>
7.1	Overview .....	<b>14</b>	11.5	静电放电警告 .....	<b>28</b>
7.2	Functional Block Diagram .....	<b>14</b>	11.6	Glossary .....	<b>28</b>
7.3	Feature Description.....	<b>14</b>	<b>12</b>	机械、封装和可订购信息 .....	<b>28</b>

## 4 修订历史记录

<b>Changes from Revision A (November 2015) to Revision B</b>	<b>Page</b>
• 增加了 TI 参考设计 .....	<b>1</b>
• Changed pin number of V+ pin in <i>Pin Functions</i> table .....	<b>3</b>
• Changed format of <i>Supply voltage</i> parameter in <i>Recommended Operating Conditions</i> table .....	<b>4</b>

<b>Changes from Original (November 2015) to Revision A</b>	<b>Page</b>
• 已从“产品预览”更改为“量产数据” .....	<b>1</b>

## 5 Pin Configuration and Functions

**DRC Package  
10-Pin VSON  
Top View**

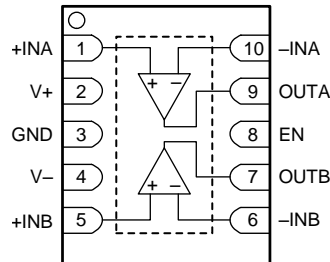

**Pin Functions**

PIN		I/O	DESCRIPTION
NAME	NO.		
GND	3	—	Connect to ground
EN	8	I	Shutdown (logic low), enable (logic high)
+IN A	1	I	Noninverting input, channel A
-IN A	10	I	Inverting input, channel A
+IN B	5	I	Noninverting input, channel B
-IN B	6	I	Inverting input, channel B
OUT A	9	O	Output, channel A
OUT B	7	O	Output, channel B
V+	2	—	Positive (highest) power supply
V-	4	—	Negative (lowest) power supply
Thermal pad			Exposed thermal die pad on underside; connect thermal die pad to V-. Soldering the thermal pad improves heat dissipation and provides specified performance.

## 6 Specifications

### 6.1 Absolute Maximum Ratings

 over operating free-air temperature range (unless otherwise noted)<sup>(1)</sup>

		MIN	MAX	UNIT
Voltage	Supply voltage, $V_S = (V+) - (V-)$		40	V
	Input voltage (signal inputs, enable, ground)	$(V-) - 0.5$	$(V+) + 0.5$	
	Input differential voltage		$\pm 0.5$	
Current	Input current (all pins except power-supply pins)		$\pm 10$	mA
	Output short-circuit <sup>(2)</sup>	Continuous		
Temperature	Operating, $T_A$	-55	125	°C
	Junction, $T_J$		200	
	Storage, $T_{stg}$	-65	150	

- (1) Stresses beyond those listed under *Absolute Maximum Ratings* may cause permanent damage to the device. These are stress ratings only, which do not imply functional operation of the device at these or any other conditions beyond those indicated under *Recommended Operating Conditions*. Exposure to absolute-maximum-rated conditions for extended periods may affect device reliability.
- (2) Short-circuit to  $V_S / 2$  (ground in symmetrical dual supply setups), one amplifier per package.

### 6.2 ESD Ratings

		VALUE	UNIT
$V_{(ESD)}$ Electrostatic discharge	Human-body model (HBM), per ANSI/ESDA/JEDEC JS-001 <sup>(1)</sup>	$\pm 4000$	V
	Charged-device model (CDM), per JEDEC specification JESD22-C101 <sup>(2)</sup>	$\pm 1500$	

- (1) JEDEC document JEP155 states that 500-V HBM allows safe manufacturing with a standard ESD control process.
- (2) JEDEC document JEP157 states that 250-V CDM allows safe manufacturing with a standard ESD control process.

### 6.3 Recommended Operating Conditions

over operating free-air temperature range (unless otherwise noted)

		MIN	NOM	MAX	UNIT
Supply voltage, $(V+) - (V-)$	Single-supply	4		36	V
	Dual-supply	$\pm 2$		$\pm 18$	
Specified temperature		-40		125	°C

### 6.4 Thermal Information

THERMAL METRIC <sup>(1)</sup>		OPA1622	UNIT
		DRC (SON)	
		10 PINS	
$R_{\theta JA}$	Junction-to-ambient thermal resistance	47.6	°C/W
$R_{\theta JC(top)}$	Junction-to-case (top) thermal resistance	58.1	°C/W
$R_{\theta JB}$	Junction-to-board thermal resistance	22.0	°C/W
$\Psi_{JT}$	Junction-to-top characterization parameter	0.9	°C/W
$\Psi_{JB}$	Junction-to-board characterization parameter	22.2	°C/W
$R_{\theta JC(bot)}$	Junction-to-case (bottom) thermal resistance	4.1	°C/W

- (1) For more information about traditional and new thermal metrics, see the *IC Package Thermal Metrics* application report, [SPRA953](#).

## 6.5 Electrical Characteristics:

at  $T_A = +25^\circ\text{C}$ ,  $V_S = \pm 2\text{ V}$  to  $\pm 18\text{ V}$ ,  $V_{CM} = V_{OUT} = \text{midsupply}$ , and  $R_L = 1\text{ k}\Omega$  (unless otherwise noted)

PARAMETER		TEST CONDITIONS	MIN	TYP	MAX	UNIT	
<b>AUDIO PERFORMANCE</b>							
THD+N	Total harmonic distortion + noise	$G = 1$ , $f = 1\text{ kHz}$ , $V_{OUT} = 3.5 V_{RMS}$ , $R_L = 2\text{ k}\Omega$ , 80-kHz measurement bandwidth	0.000024%				
				-132		dB	
		$G = 1$ , $f = 1\text{ kHz}$ , $V_{OUT} = 3.5 V_{RMS}$ , $R_L = 600\ \Omega$ , 80-kHz measurement bandwidth	0.000025%				
				-132		dB	
		$G = 1$ , $f = 1\text{ kHz}$ , $P_{OUT} = 10\text{ mW}$ , $R_L = 128\ \Omega$ , 80-kHz measurement bandwidth	0.000071%				
			-123		dB		
		$G = 1$ , $f = 1\text{ kHz}$ , $P_{OUT} = 10\text{ mW}$ , $R_L = 32\ \Omega$ , 80-kHz measurement bandwidth	0.000149%				
				-116		dB	
		$G = 1$ , $f = 1\text{ kHz}$ , $P_{OUT} = 10\text{ mW}$ , $R_L = 16\ \Omega$ , 80-kHz measurement bandwidth	0.000214%				
				-113		dB	
IMD	Intermodulation distortion	SMPTE/DIN two-tone, 4:1 (60 Hz and 7 kHz), $G = 1$ , $V_O = 3 V_{RMS}$ , $R_L = 2\text{ k}\Omega$ , 90-kHz measurement bandwidth	0.000018%				
				-135		dB	
		CCIF twin-tone (19 kHz and 20 kHz), $G = 1$ , $V_O = 3 V_{RMS}$ , $R_L = 2\text{ k}\Omega$ , 90-kHz measurement bandwidth	0.00005%				
				-126		dB	
<b>FREQUENCY RESPONSE</b>							
GBW	Gain-bandwidth product	$G = 1000$		32		MHz	
		$G = 1$		8			
SR	Slew rate	$G = -1$		10		V/ $\mu\text{s}$	
	Full-power bandwidth <sup>(1)</sup>	$V_O = 1 V_P$		1.6		MHz	
	Overload recovery time	$G = -10$		300		ns	
	Channel separation (dual)	$f = 1\text{ kHz}$		140		dB	
<b>NOISE</b>							
	Input voltage noise	$f = 20\text{ Hz}$ to $20\text{ kHz}$		2.1		$\mu\text{V}_{PP}$	
$e_n$	Input voltage noise density <sup>(2)</sup>	$f = 10\text{ Hz}$		10		$\text{nV}/\sqrt{\text{Hz}}$	
		$f = 100\text{ Hz}$		4			
		$f = 1\text{ kHz}$		2.8			
$i_n$	Input current noise density	$f = 10\text{ Hz}$		2.5		$\text{pA}/\sqrt{\text{Hz}}$	
		$f = 1\text{ kHz}$		0.8			
<b>OFFSET VOLTAGE</b>							
$V_{OS}$	Input offset voltage			$\pm 100$	$\pm 500$	$\mu\text{V}$	
		$T_A = -40^\circ\text{C}$ to $+125^\circ\text{C}$			$\pm 600$		
$dV_{OS}/dT$	Input offset voltage drift <sup>(2)</sup>	$T_A = -40^\circ\text{C}$ to $+125^\circ\text{C}$		0.5	2.5	$\mu\text{V}/^\circ\text{C}$	
PSRR	Power-supply rejection ratio			0.1	3	$\mu\text{V}/\text{V}$	
<b>INPUT BIAS CURRENT</b>							
$I_B$	Input bias current			1.2	2.0	$\mu\text{A}$	
		$T_A = -40^\circ\text{C}$ to $+125^\circ\text{C}$ <sup>(2)</sup>			2.2		
$I_{OS}$	Input offset current			$\pm 10$	$\pm 50$	nA	
		$T_A = -40^\circ\text{C}$ to $+125^\circ\text{C}$ <sup>(2)</sup>			$\pm 80$		
<b>INPUT VOLTAGE RANGE</b>							
$V_{CM}$	Common-mode voltage range		$(V-) + 1.5$		$(V+) - 1$	V	
CMRR	Common-mode rejection ratio	$(V-) + 1.5\text{ V} \leq V_{CM} \leq (V+) - 1\text{ V}$ , $T_A = -40^\circ\text{C}$ to $+125^\circ\text{C}$	110	127		dB	

(1) Full-power bandwidth =  $SR / (2\pi \times V_P)$ , where SR = slew rate.

(2) Specified by design and characterization.

**Electrical Characteristics: (continued)**

 at  $T_A = +25^\circ\text{C}$ ,  $V_S = \pm 2\text{ V to } \pm 18\text{ V}$ ,  $V_{CM} = V_{OUT} = \text{mid supply}$ , and  $R_L = 1\text{ k}\Omega$  (unless otherwise noted)

PARAMETER		TEST CONDITIONS	MIN	TYP	MAX	UNIT
<b>INPUT IMPEDANCE</b>						
	Differential		60k    0.8			$\Omega$    pF
	Common-mode		500M    0.9			$\Omega$    pF
<b>OPEN-LOOP GAIN</b>						
$A_{OL}$	Open-loop voltage gain	$(V-) + 2\text{ V} \leq V_O \leq (V+) - 2\text{ V}$ , $R_L = 32\ \Omega$ , $V_S = \pm 5\text{ V}$	114	120		dB
		$(V-) + 1.5\text{ V} \leq V_O \leq (V+) - 1.5\text{ V}$ , $R_L = 600\ \Omega$ , $V_S = \pm 18\text{ V}$	120	136		
<b>OUTPUT</b>						
$V_O$	Voltage output swing from rail	Positive rail	No load	800		mV
			$R_L = 600\ \Omega$	900		
		Negative rail	No load	800		
			$R_L = 600\ \Omega$	900		
$I_{OUT}$	Output current		See <a href="#">图 38</a> and <a href="#">图 39</a>		mA	
$Z_O$	Open-loop output impedance		See <a href="#">图 40</a>		$\Omega$	
$I_{SC}$	Short-circuit current	$V_S = \pm 18\text{ V}$	+145 / -130		mA	
$C_{LOAD}$	Capacitive load drive		See <a href="#">图 24</a>		pF	
<b>ENABLE PIN</b>						
$V_{IH}$	Logic high threshold		0.82		V	
		$T_A = -40^\circ\text{C to } +125^\circ\text{C}$	0.95			
$V_{IL}$	Logic low threshold		0.78		V	
		$T_A = -40^\circ\text{C to } +125^\circ\text{C}$	0.65			
$I_{IH}$	Input current	$V_{EN} = 1.8\text{ V}$	1.5		$\mu\text{A}$	
<b>POWER SUPPLY</b>						
$I_Q$	Quiescent current (per channel)	$V_{EN} = 2.0\text{ V}$ , $I_{OUT} = 0\text{ A}$		2.6	3.3	mA
			$T_A = -40^\circ\text{C to } +125^\circ\text{C}^{(2)}$	4.2		
		$V_{EN} = 0\text{ V}$ , $I_{OUT} = 0\text{ A}$	5	10	$\mu\text{A}$	

### 6.6 Typical Characteristics

at  $T_A = 25^\circ\text{C}$ ,  $V_S = \pm 18\text{ V}$ , and  $R_L = 2\text{ k}\Omega$  (unless otherwise noted)



图 1. Input Offset Voltage Histogram



图 2. Input Offset Voltage Drift Histogram

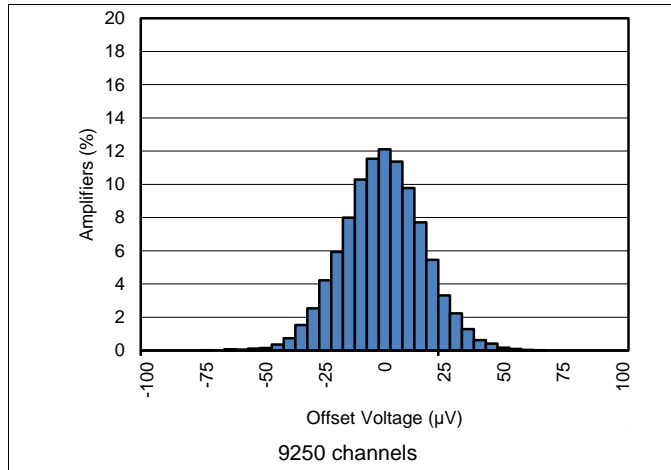

图 3. Input Offset Voltage vs Temperature

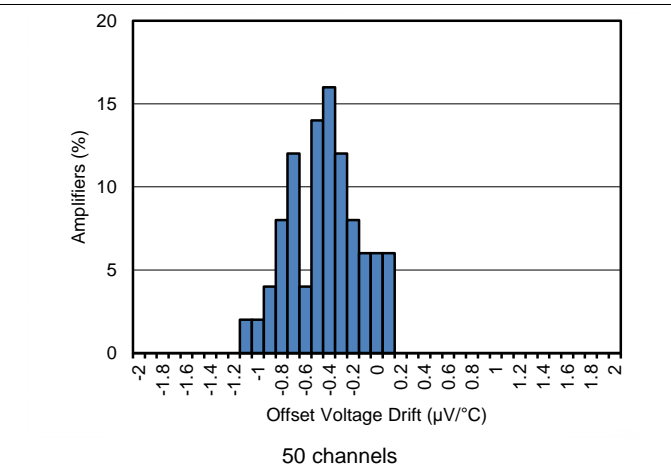

图 4. Input Offset Voltage vs Common-Mode Voltage

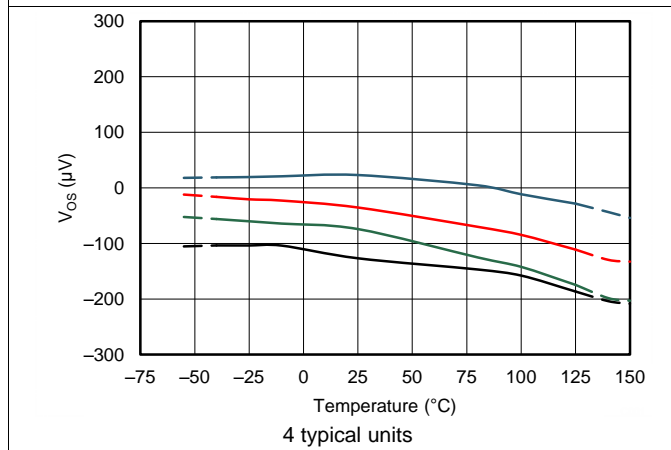

图 5. Input Voltage Noise Spectral Density vs Frequency

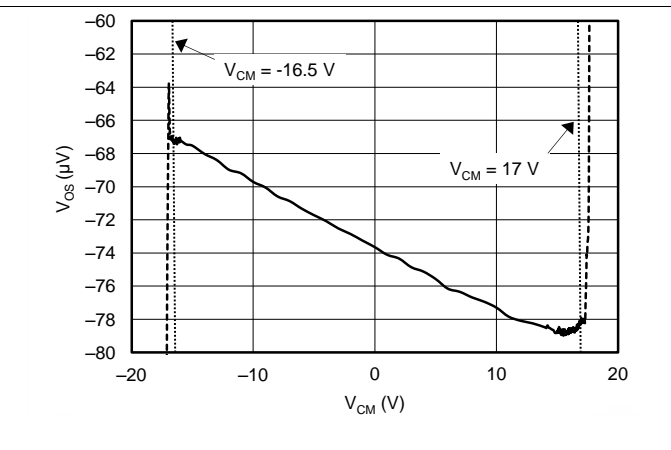

图 6. Input Current Noise Spectral Density vs Frequency

Typical Characteristics (接下页)

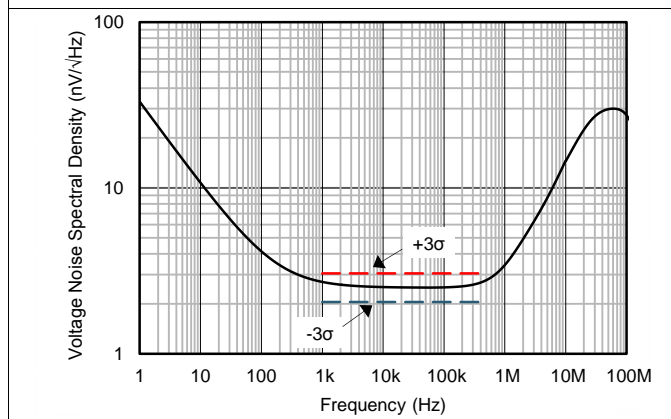
at  $T_A = 25^\circ\text{C}$ ,  $V_S = \pm 18\text{ V}$ , and  $R_L = 2\text{ k}\Omega$  (unless otherwise noted)

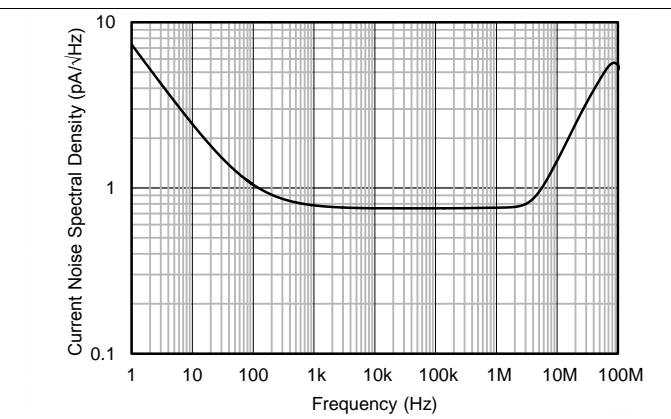

图 7. 0.1-Hz to 10-Hz Noise



图 8. Voltage Noise vs Source Resistance

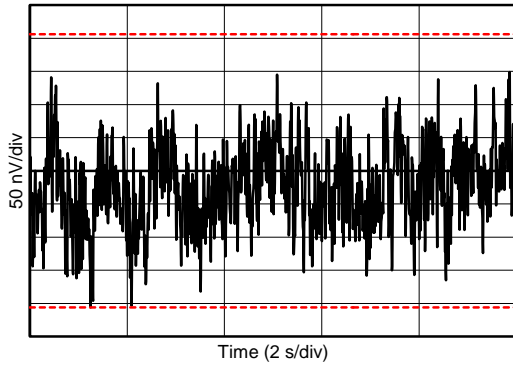

图 9. Maximum Output Voltage vs Frequency

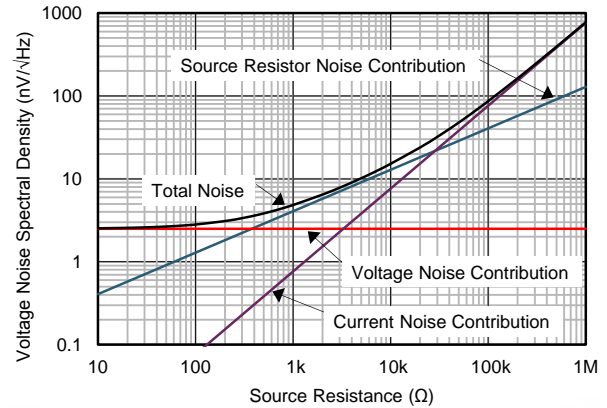

图 10. Open-Loop Gain and Phase vs Frequency

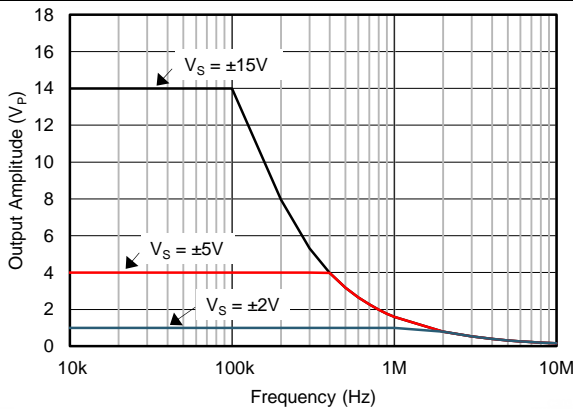

图 11. Open-Loop Gain vs Temperature

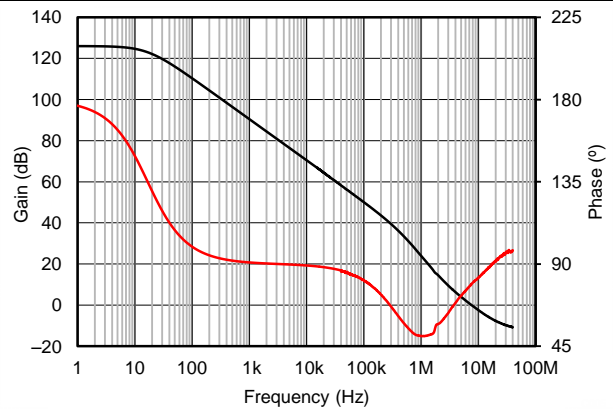

图 12. Open-Loop Gain vs Temperature

Typical Characteristics (接下页)

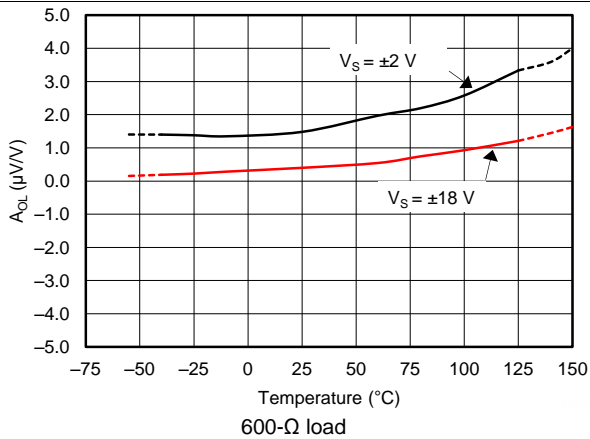
at  $T_A = 25^\circ\text{C}$ ,  $V_S = \pm 18\text{ V}$ , and  $R_L = 2\text{ k}\Omega$  (unless otherwise noted)

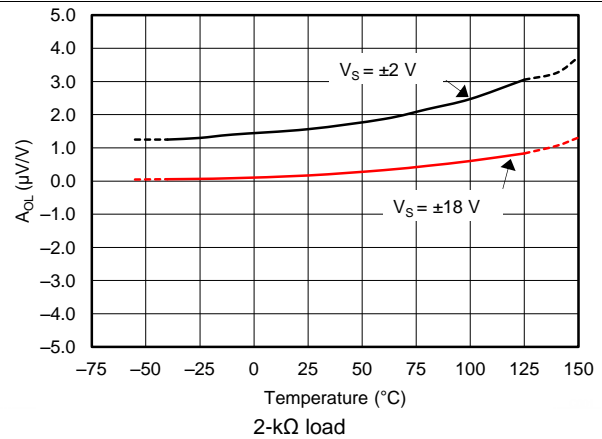

图 13. Closed-Loop Gain vs Frequency



图 14. THD+N Ratio vs Frequency

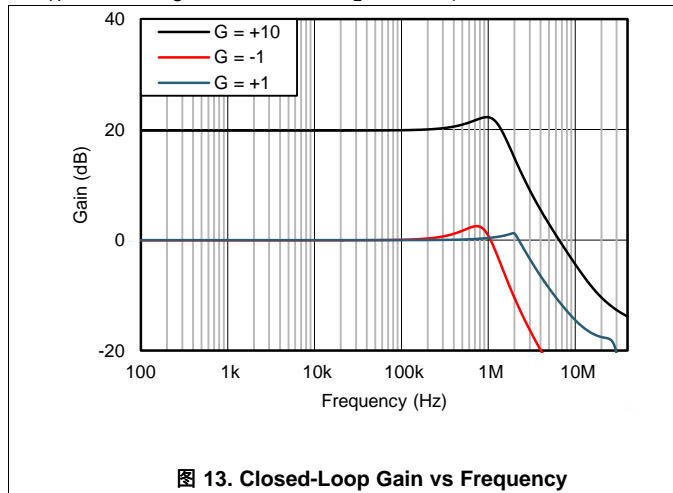

图 15. THD+N Ratio vs Frequency

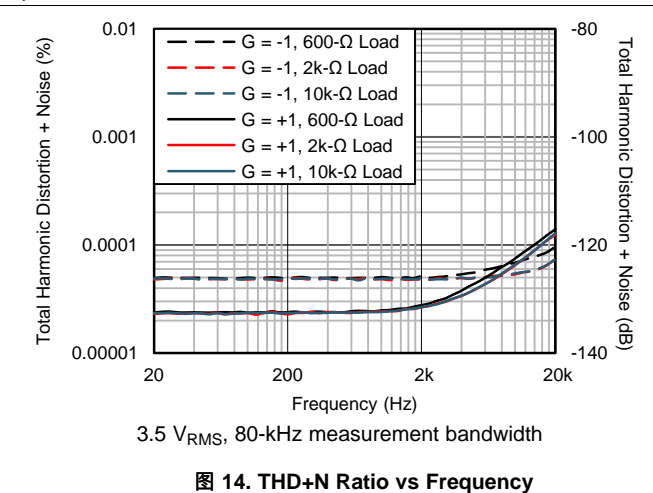

图 16. THD+N Ratio vs Output Amplitude

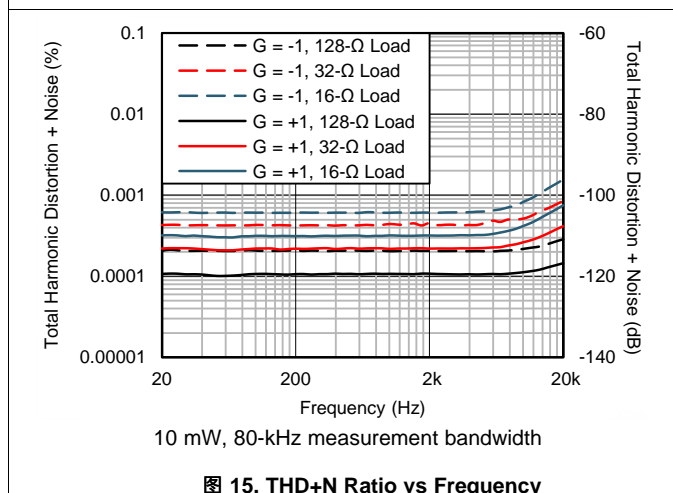

图 17. THD+N Ratio vs Output Amplitude

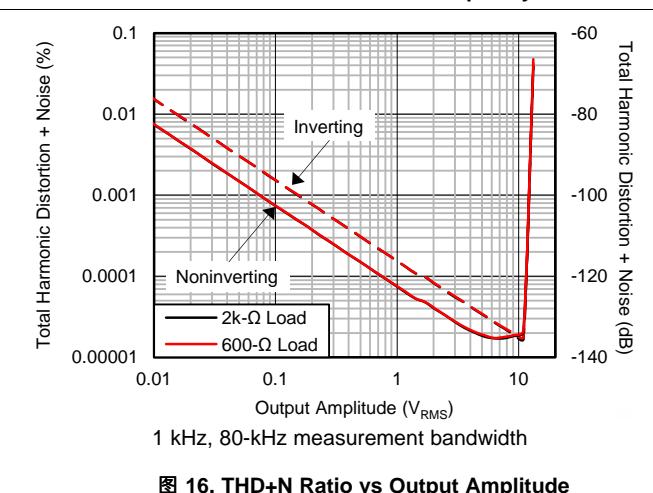

图 18. Intermodulation Distortion vs Output Amplitude

Typical Characteristics (接下页)

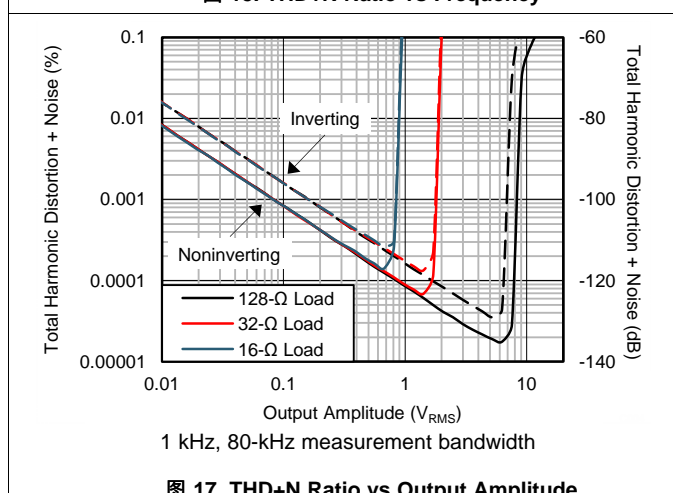
at  $T_A = 25^\circ\text{C}$ ,  $V_S = \pm 18\text{ V}$ , and  $R_L = 2\text{ k}\Omega$  (unless otherwise noted)

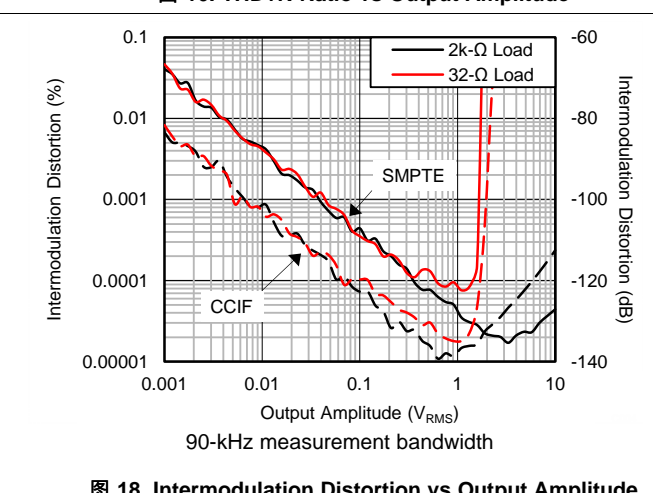

图 19. Channel Separation vs Frequency



图 20. PSRR vs Frequency (Referred to Input)

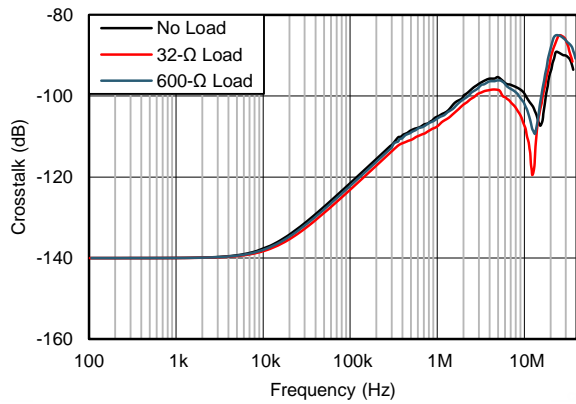

图 21. PSRR vs Temperature

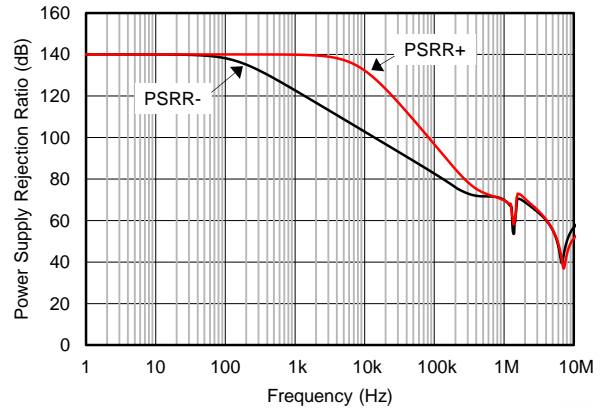

图 22. CMRR vs Frequency (Referred to Input)

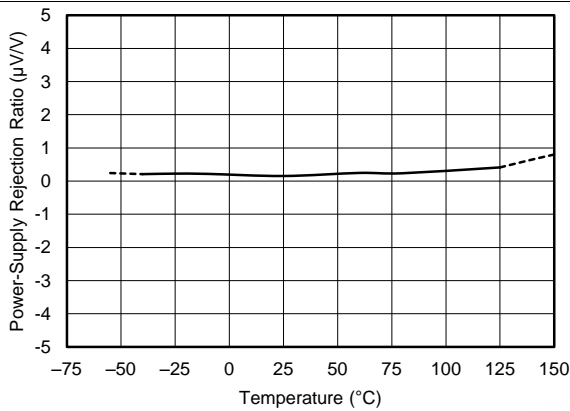

图 23. CMRR vs Temperature

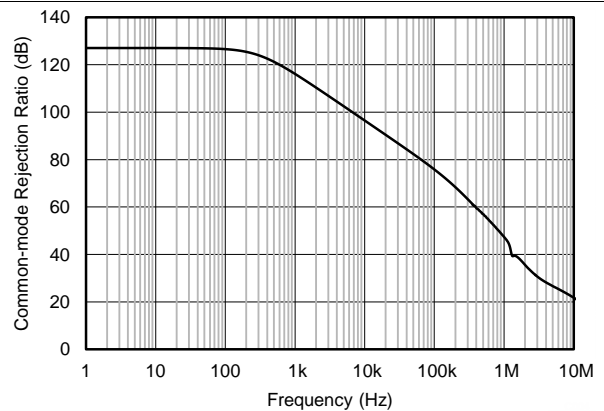

图 24. Phase Margin vs Capacitive Load

Typical Characteristics (接下页)

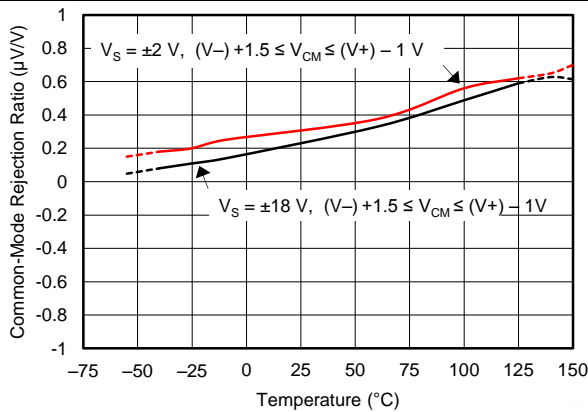
at  $T_A = 25^\circ\text{C}$ ,  $V_S = \pm 18\text{ V}$ , and  $R_L = 2\text{ k}\Omega$  (unless otherwise noted)

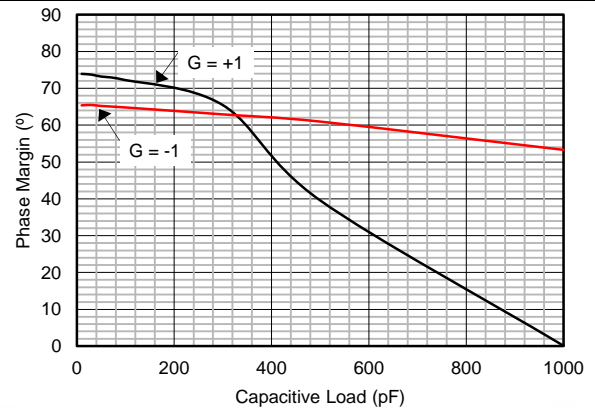
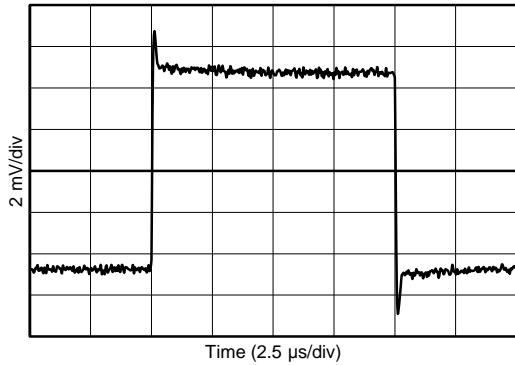

$G = 1, 10\text{ mV}$

图 25. Small-Signal Step Response

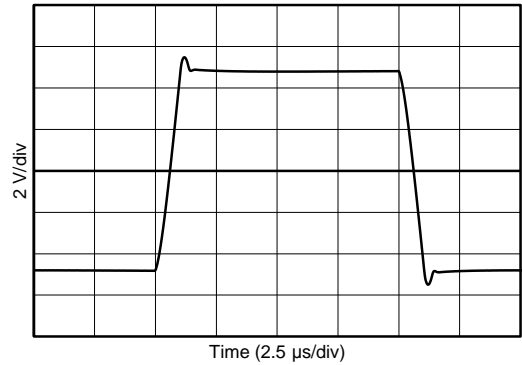

$G = 1, 10\text{ V}$

图 26. Large-Signal Step Response

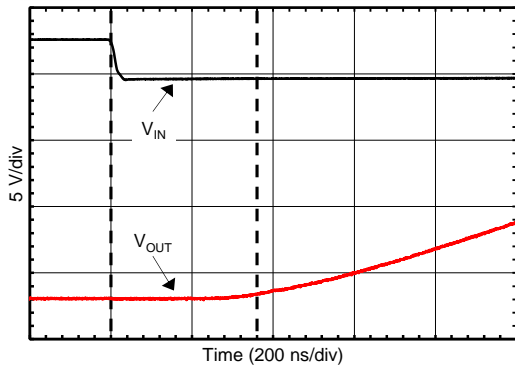

$G = -10$

图 27. Negative Overload Recovery

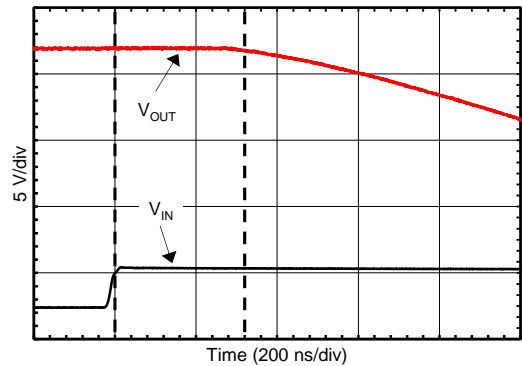

$G = -10$

图 28. Positive Overload Recovery



图 29. No Phase Reversal



图 30.  $I_B$  vs Temperature

Typical Characteristics (接下页)

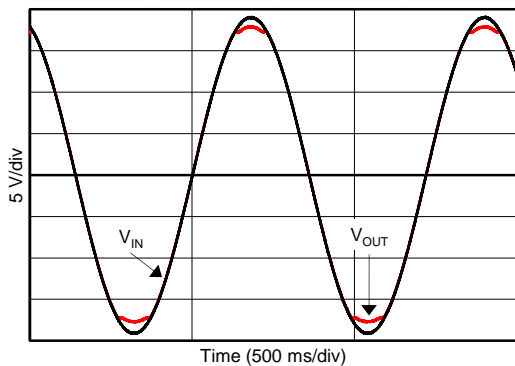
at  $T_A = 25^\circ\text{C}$ ,  $V_S = \pm 18\text{ V}$ , and  $R_L = 2\text{ k}\Omega$  (unless otherwise noted)

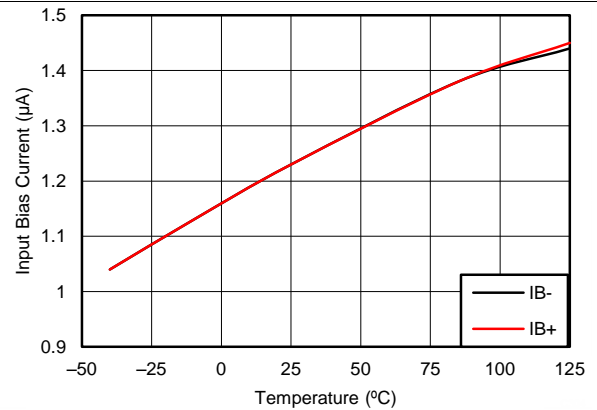

图 31.  $I_{OS}$  vs Temperature



图 32.  $I_B$  vs Common-Mode Voltage

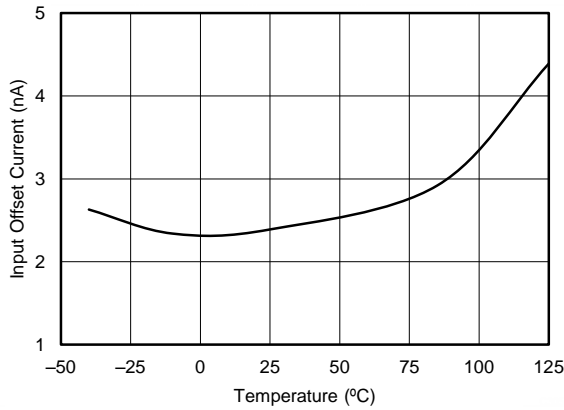

图 33.  $I_B$  vs Common-Mode Voltage

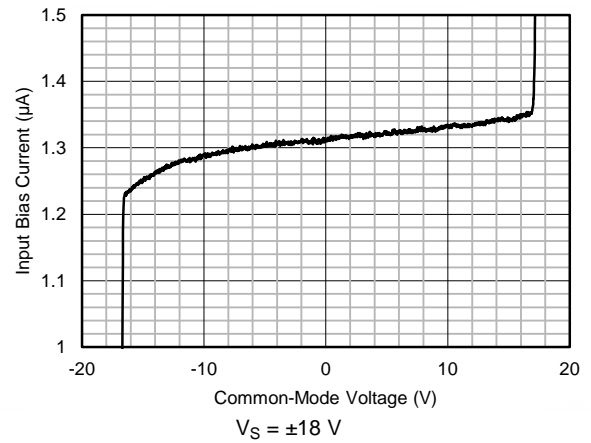

图 34. Quiescent Current vs Temperature

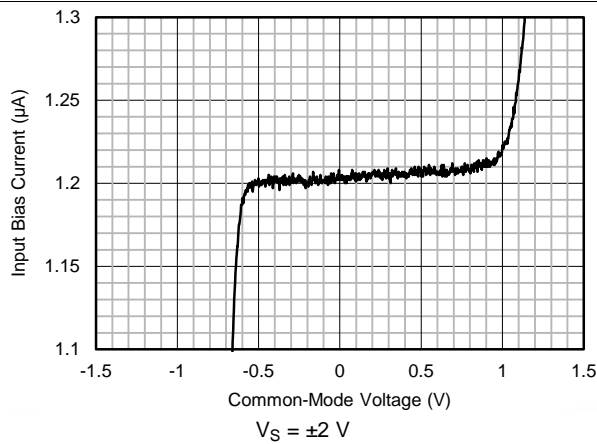

图 35. Quiescent Current vs Supply Voltage

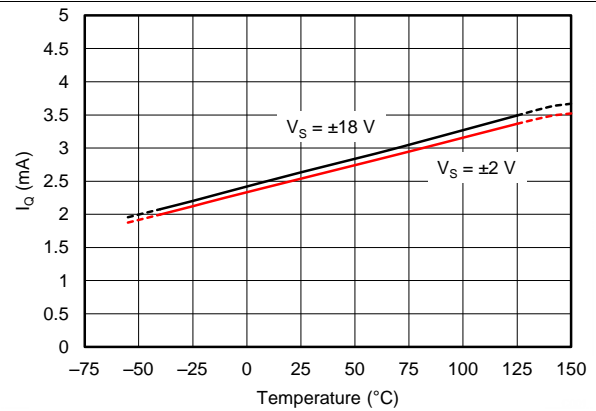

图 36. Quiescent Current vs Enable Voltage

Typical Characteristics (接下页)

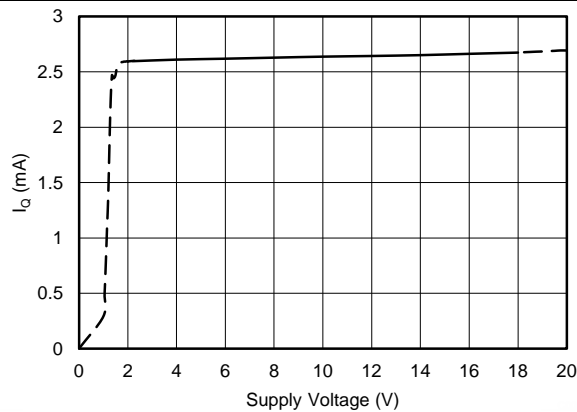
at  $T_A = 25^\circ\text{C}$ ,  $V_S = \pm 18\text{ V}$ , and  $R_L = 2\text{ k}\Omega$  (unless otherwise noted)

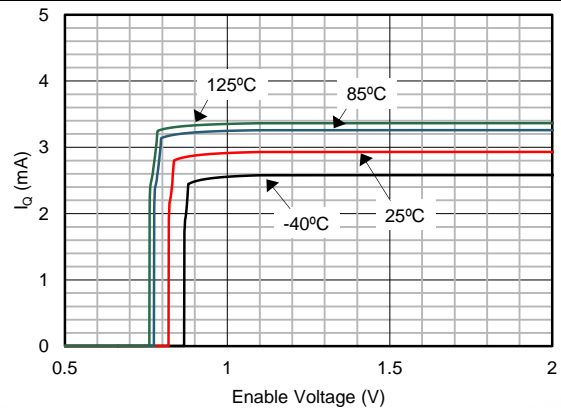

图 37. Short-Circuit Current vs Temperature



图 38. Positive Output Voltage vs Output Current

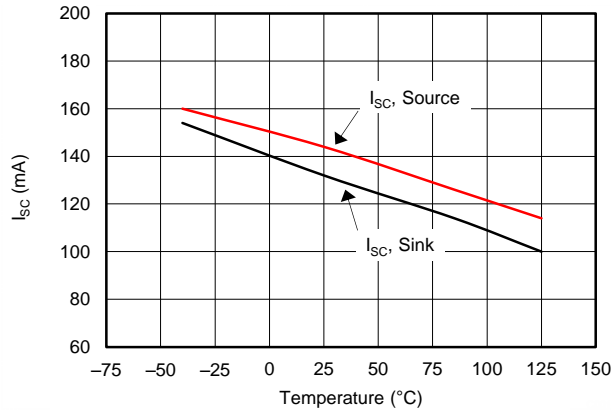

图 39. Negative Output Voltage vs Output Current

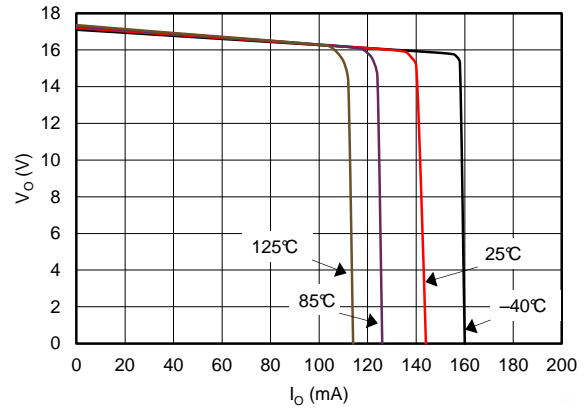

图 40. Open-Loop Output Impedance vs Frequency

## 7 Detailed Description

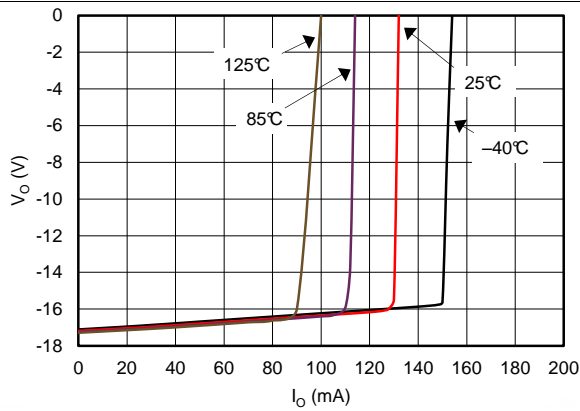
### 7.1 Overview

The OPA1622, dual, bipolar-input, audio operational amplifier uses a unique internal topology to deliver high output current with extremely low distortion while consuming minimal supply current. A single gain stage architecture, combining a high-gain transconductance input stage and a unity gain output stage, allows the OPA1622 to achieve an open-loop gain of 136 dB, even with 600-Ω loads.

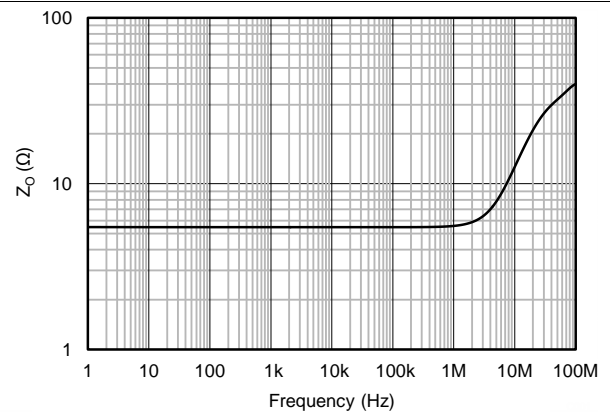
The output stage of the OPA1622 is designed specifically to source and sink large amounts of current without degrading amplifier linearity. High-order distortion harmonics, produced by output stage crossover distortion, are greatly reduced with this design. The OPA1622 output stage also provides exceptionally low open-loop output impedance that improves stability with capacitive loads and is protected against short-circuit events.

A separate enable circuit maintains control of the input and output stage when the amplifier is placed into its shutdown mode and limits transients at the amplifier output when transitioning to and from this state. The enable circuit features logic levels referenced to the amplifier ground pin. This configuration simplifies the interface between the amplifier and the ground-referenced GPIO pins of microcontrollers. The addition of a ground pin to the amplifier provides several additional benefits. For example, the compensation capacitor between the input and output stages of the OPA1622 is referenced to the ground pin, greatly improving PSRR.

### 7.2 Functional Block Diagram

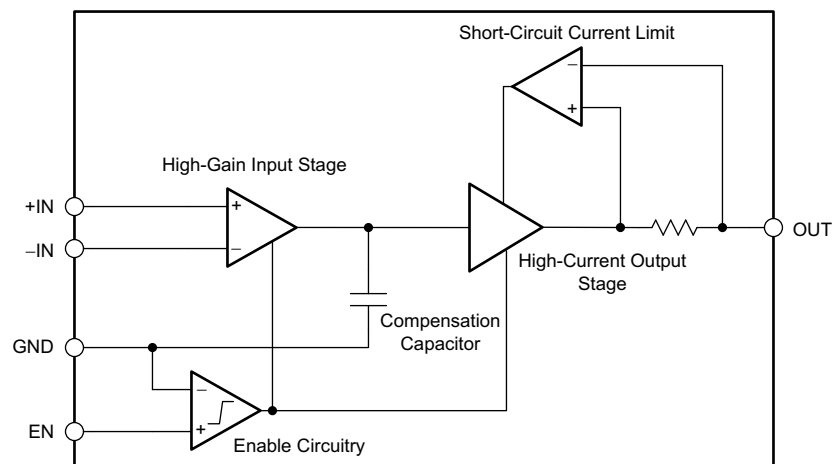

Copyright © 2016, Texas Instruments Incorporated

图 41. OPA1622 Simplified Schematic

### 7.3 Feature Description

#### 7.3.1 Power Dissipation

The OPA1622 is capable of high output current with power-supply voltages up to ±18 V. Internal power dissipation increases when operating at high supply voltages. The power dissipated in the op amp ( $P_{OPA}$ ) is calculated using 公式 1:

$$P_{OPA} = (V_+ - V_{OUT}) \times I_{OUT} = (V_+ - V_{OUT}) \times \frac{V_{OUT}}{R_L} \quad (1)$$

## Feature Description (接下页)

In order to calculate the worst-case power dissipation in the op amp, the ac and dc cases must be considered separately.

In the case of constant output current (dc) to a resistive load, the maximum power dissipation in the op amp occurs when the output voltage is half the positive supply voltage. This calculation assumes that the op amp is sourcing current from the positive supply to a grounded load. If the op amp sinks current from a grounded load, modify 公式 2 to include the negative supply voltage instead of the positive.

$$P_{\text{OPA(MAX\_DC)}} = P_{\text{OPA}} \left( \frac{V_+}{2} \right) = \frac{V_+^2}{4R_L} \quad (2)$$

The maximum power dissipation in the op amp for a sinusoidal output current (ac) to a resistive load occurs when the peak output voltage is  $2/\pi$  times the supply voltage, given symmetrical supply voltages:

$$P_{\text{OPA(MAX\_AC)}} = P_{\text{OPA}} \left( \frac{2V_+}{\pi} \right) = \frac{2 \cdot V_+^2}{\pi^2 \cdot R_L} \quad (3)$$

The dominant pathway for the OPA1622 to dissipate heat is through the package thermal pad and pins to the PCB. Copper leadframe construction used in the OPA1622 improves heat dissipation compared to conventional materials. PCB layout greatly affects thermal performance. Connect the OPA1622 package thermal pad to a copper pour at the most negative supply potential. This copper pour can be connected to a larger copper plane within the PCB using vias to improve power dissipation. 图 42 shows an analogous thermal circuit that can be used for approximating the junction temperature of the OPA1622. The power dissipated in the OPA1622 is represented by current source  $P_D$ ; the ambient temperature is represented by voltage source  $25^\circ\text{C}$ ; and the junction-to-board and board-to-ambient thermal resistances are represented by resistors  $\theta_{JB}$  and  $\theta_{BA}$ , respectively. The board-to-ambient thermal resistance is unique to every application. The sum of  $\theta_{JB}$  and  $\theta_{BA}$  is the junction-to-ambient thermal resistance of the system. The value for junction-to-ambient thermal resistance reported in the [Thermal Information](#) table is determined using the JEDEC standard test PCB. The voltages in the analogous thermal circuit at the points  $T_J$  and  $T_{PCB}$  represent the OPA1622 junction and PCB temperatures, respectively.



图 42. Approximate Thermal System Model of the OPA1622 Soldered to a PCB.

### 7.3.2 Thermal Shutdown

If the junction temperature of the OPA1622 exceeds  $175^\circ\text{C}$ , a thermal shutdown circuit disables the amplifier in order to protect the device from damage. The amplifier is automatically re-enabled after the junction temperature falls below approximately  $160^\circ\text{C}$ . If the condition that caused excessive power dissipation has not been removed, the amplifier oscillates between a shutdown and enabled state until the output fault is corrected.

## Feature Description (接下页)

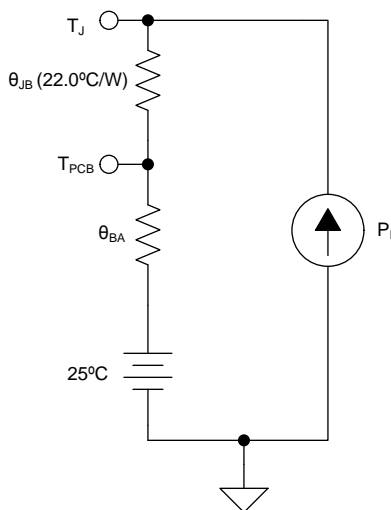
### 7.3.3 Enable Pin

The enable pin (EN) of the OPA1622 is used to toggle the amplifier enabled and disabled states. The logic levels defining these two states are:  $V_{EN} \leq 0.78 \text{ V}$  (shutdown mode), and  $V_{EN} \geq 0.82 \text{ V}$  (enabled). These threshold levels are referenced to the device ground pin. The enable pin can be driven by a GPIO pin from the system controller, discrete logic gates, or can be connected directly to the V+ supply. Do not leave the enable pin floating because the amplifier is prevented from being enabled. Likewise, do not place GPIO pins used to control the enable pin in a high-impedance state because this placement also prevents the amplifier from being enabled. A small current flows into the enable pin when a voltage is applied. Using the simplified internal schematic shown in 图 43, use 公式 4 to estimate the enable pin current:

$$I_{EN} = \frac{V_{EN} - 0.7 \text{ V}}{700 \text{ k}\Omega} \tag{4}$$

As illustrated in 图 43, the enable pin is protected by diodes to the amplifier power supplies. Do not connect the enable pin to voltages outside the limits defined in the *Specifications* section.



图 43. Enable Pin Simplified Internal Schematic

### 7.3.4 Ground Pin

The inclusion of a ground pin in the OPA1622 architecture allows the internal enable circuitry to be referenced to the system ground, eliminating the need for level shifting circuitry in many applications. The internal amplifier compensation capacitors are also referenced to this pin, greatly increasing the ac PSRR. For highest performance, connect the ground pin to a low-impedance reference point with minimal noise present. As shown in 图 43, the ground pin is protected by ESD diodes to the amplifier power supplies. Do not connect the ground pin to voltages outside the limits defined in the *Specifications* section.

### 7.3.5 Electrical Overstress

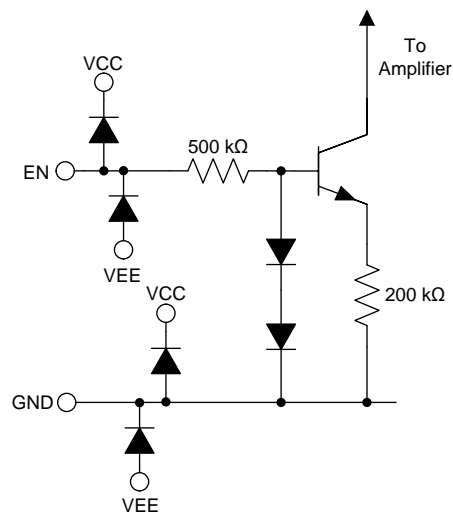
Designers often ask questions about the capability of an operational amplifier to withstand electrical overstress. These questions tend to focus on the device inputs, but can involve the supply voltage pins or even the output pin. Each of these different pin functions have electrical stress limits determined by the voltage breakdown characteristics of the particular semiconductor fabrication process and specific circuits connected to the pin. Additionally, internal electrostatic discharge (ESD) protection is built into these circuits to protect them from accidental ESD events both before and during product assembly.

Having a good understanding of this basic ESD circuitry and its relevance to an electrical overstress event is helpful. 图 44 shows the ESD circuits contained in the OPA1622. The ESD protection circuitry involves several current-steering diodes connected from the input and output pins and routed back to the internal power-supply lines, where they meet at an absorption device internal to the operational amplifier. This protection circuitry is intended to remain inactive during normal circuit operation.

Feature Description (接下页)



图 44. Equivalent Internal ESD Circuitry

7.3.6 Input Protection

The input pins of the OPA1622 are protected from excessive differential voltage with back-to-back diodes, as 图 45 shows. In most circuit applications, the input protection circuitry has no consequence. However, in low-gain or  $G = +1$  circuits, fast-ramping input signals can forward bias these diodes because the output of the amplifier cannot respond quickly enough to the input ramp. If the input signal is fast enough to create this forward-bias condition, the input signal current must be limited to 10 mA or less. If the input signal current is not inherently limited, use an input series resistor ( $R_I$ ) or a feedback resistor ( $R_F$ ) to limit the signal input current. This input series resistor degrades the low-noise performance of the OPA1622 and is examined in the [Noise Performance](#) section. 图 45 shows an example configuration when both current-limiting input and feedback resistors are used.

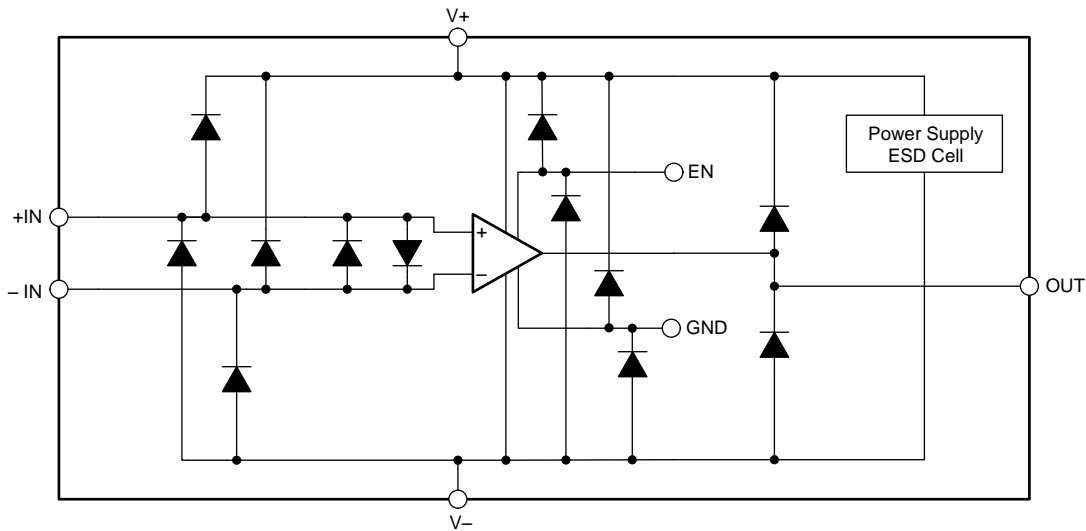

图 45. Pulsed Operation

7.4 Device Functional Modes

The OPA1622 has two operating modes determined by the voltage between the enable and ground pins: a shutdown mode ( $V_{EN} \leq 0.78V$ ) and an enabled mode ( $V_{EN} \geq 0.82V$ ). The measured datasheet performance parameters specified in the [Typical Characteristics](#) and [Specifications](#) sections are given with the amplifier in the enabled mode, unless otherwise noted.

## Device Functional Modes (接下页)

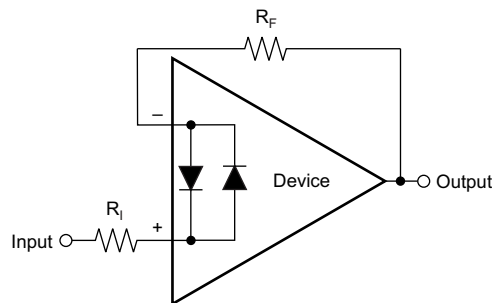
### 7.4.1 Shutdown Mode

When the enable pin voltage is below the logic low threshold, the OPA1622 enters a shutdown mode with minimal power consumption. In this state the output transistors of the amplifier are not powered on. However, do not consider the amplifier output to be high-impedance. Applying signals to the output of the OPA1622 while the device is in the shutdown mode can parasitically power the output stage, causing the OPA1622 output to draw current.

The OPA1622 enable circuitry limits transients at the output when transitioning into or out of shutdown mode. However, small output transients do still accompany this transition, as illustrated in 图 46 and 图 47. Note that in both figures the time scale is 1  $\mu$ s per division, indicating that the output transients are extremely brief in nature, and therefore not likely to be audible in headphone applications.

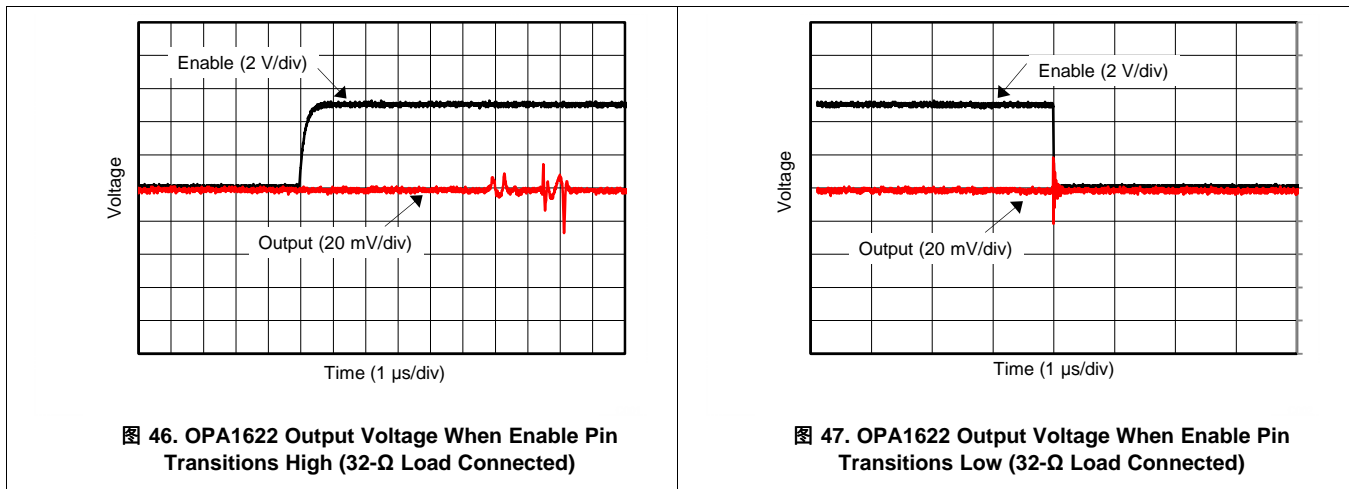

### 7.4.2 Output Transients During Power Up and Power Down

To minimize the possibility of output transients that might produce an audible *click* or *pop*, ramp the supply voltages for the OPA1622 symmetrically to their nominal values. Asymmetrical supply ramping can cause output transients during power up that can be audible in headphone applications. If possible, hold the enable pin low while the power supplies are ramping up or down. If the enable pin is not being independently controlled (for example, by a GPIO pin), use a voltage divider to hold the enable pin voltage below the logic-high threshold until the power supplies reach the specified minimum voltage, as shown in 图 48.



图 48. Voltage Divider Used to Hold Enable Low at Power-Up or Power-Down

## 8 Application and Implementation

### 注

Information in the following applications sections is not part of the TI component specification, and TI does not warrant its accuracy or completeness. TI's customers are responsible for determining suitability of components for their purposes. Customers should validate and test their design implementation to confirm system functionality.

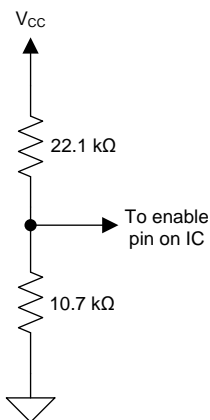
### 8.1 Application Information

The low noise and distortion of the OPA1622 make the device well suited for a variety of applications in professional and consumer audio products. However, these same performance metrics also make the OPA1622 useful for industrial, test-and-measurement, and data-acquisition applications. The example shown here is only one possible application where the OPA1622 provides exceptional performance.

#### 8.1.1 Noise Performance

图 49 shows the total circuit noise for varying source impedances with the op amp in a unity-gain configuration (no feedback resistor network, and therefore no additional noise contributions).

The OPA1622 is shown with total circuit noise calculated. The op amp contributes both a voltage noise component and a current noise component. The voltage noise is commonly modeled as a time-varying component of the offset voltage. The current noise is modeled as the time-varying component of the input bias current, and reacts with the source resistance to create a voltage component of noise. Therefore, the lowest noise op amp for a given application depends on the source impedance. For low source impedance, current noise is negligible, and voltage noise generally dominates. The low voltage and current noise of the OPA1622 op amp make the device an excellent choice for use in applications where the source impedance is less than 10 kΩ.

##### 8.1.1.1 Noise Calculations

The equations in 图 50 show the calculation of the total circuit noise using these parameters:

- $e_n$  = voltage noise
- $I_n$  = current noise
- $R_S$  = source impedance
- $k$  = Boltzmann's constant =  $1.38 \times 10^{-23}$  J/K
- $T$  = temperature in kelvins (K)

##### 8.1.1.2 Application Curve



图 49. Noise Performance of the OPA1622 in a Unity-Gain Buffer Configuration

## Application Information (接下页)

### 8.1.1.3 Basic Noise Calculations

Designing low-noise op amp circuits requires careful consideration of a variety of possible noise contributors, such as noise from the signal source, noise generated in the op amp, and noise from the feedback network resistors. The total noise of the circuit is the root sum squared combination of all noise components.

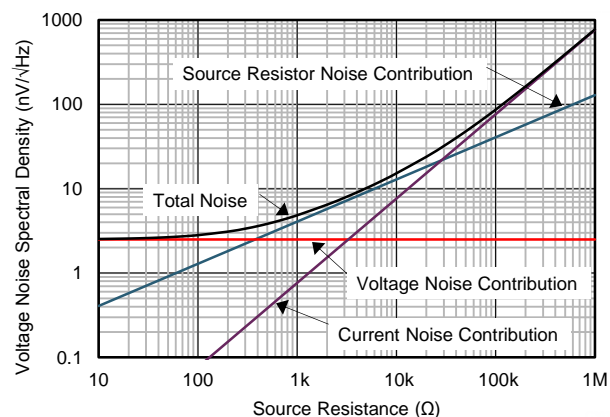
The resistive portion of the source impedance produces thermal noise proportional to the square root of the resistance. 图 49 plots this function. The source impedance is usually fixed; consequently, select the op amp and the feedback resistors to minimize the respective contributions to the total noise.

图 50 shows both inverting and noninverting op amp circuit configurations with gain. In circuit configurations with gain, the feedback network resistors also contribute noise.

The current noise of the op amp reacts with the feedback resistors to create additional noise components. Choose feedback resistor values that make these noise sources negligible. The equations for total noise are shown for both configurations.

#### Noise in Noninverting Gain Configuration

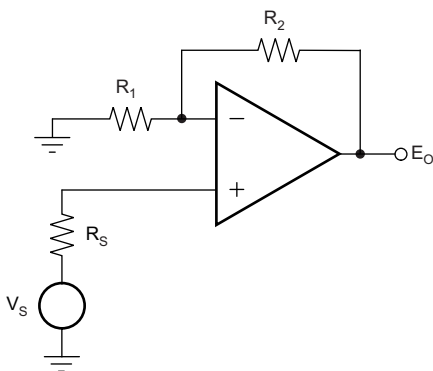

Noise at the output:

$$E_O^2 = \left[ 1 + \frac{R_2}{R_1} \right]^2 e_n^2 + e_1^2 + e_2^2 + (i_n R_2)^2 + e_S^2 + (i_n R_S)^2 \left[ 1 + \frac{R_2}{R_1} \right]^2$$

where

- $e_S = \sqrt{4kTR_S} \times \left[ 1 + \frac{R_2}{R_1} \right]$  = thermal noise of  $R_S$
- $e_1 = \sqrt{4kTR_1} \times \left[ \frac{R_2}{R_1} \right]$  = thermal noise of  $R_1$
- $e_2 = \sqrt{4kTR_2}$  = thermal noise of  $R_2$

#### Noise in Inverting Gain Configuration

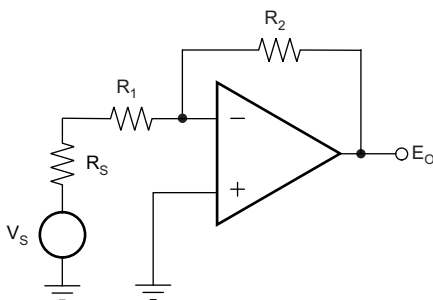

Noise at the output:

$$E_O^2 = \left[ 1 + \frac{R_2}{R_1 + R_S} \right]^2 e_n^2 + e_1^2 + e_2^2 + (i_n R_2)^2 + e_S^2$$

where

- $e_S = \sqrt{4kTR_S} \times \left[ \frac{R_2}{R_1 + R_S} \right]$  = thermal noise of  $R_S$
- $e_1 = \sqrt{4kTR_1} \times \left[ \frac{R_2}{R_1 + R_S} \right]$  = thermal noise of  $R_1$
- $e_2 = \sqrt{4kTR_2}$  = thermal noise of  $R_2$

For the OPA1622 at 1 kHz,  $e_n = 2.8 \text{ nV}/\sqrt{\text{Hz}}$  and  $i_n = 800 \text{ fA}/\sqrt{\text{Hz}}$ .

图 50. Noise Calculation in Gain Configurations

## Application Information (接下页)

### 8.1.2 Total Harmonic Distortion Measurements

The distortion produced by OPA1622 is below the measurement limit of many commercially-available distortion analyzers. However, a special test circuit, as shown in 图 51, can be used to extend the measurement capabilities.



图 51. Distortion Test Circuit

Consider op amp distortion an internal error source that is referred to the input. 图 51 shows a circuit that causes the op amp distortion to be 101 times (approximately 40 dB) greater than that normally produced by the op amp. The addition of  $R_3$  to the otherwise standard noninverting amplifier configuration alters the feedback factor or noise gain of the circuit. The closed-loop gain is unchanged, but the feedback available for error correction is reduced by a factor of 101, thus extending the resolution by 101. Note that the input signal and load applied to the op amp are the same as with conventional feedback without  $R_3$ . Keep the value of  $R_3$  small to minimize its effect on the distortion measurements.

Verify the validity of this technique by duplicating measurements at high gain or high frequency where the distortion is within the measurement capability of the test equipment.

## 8.2 Typical Application

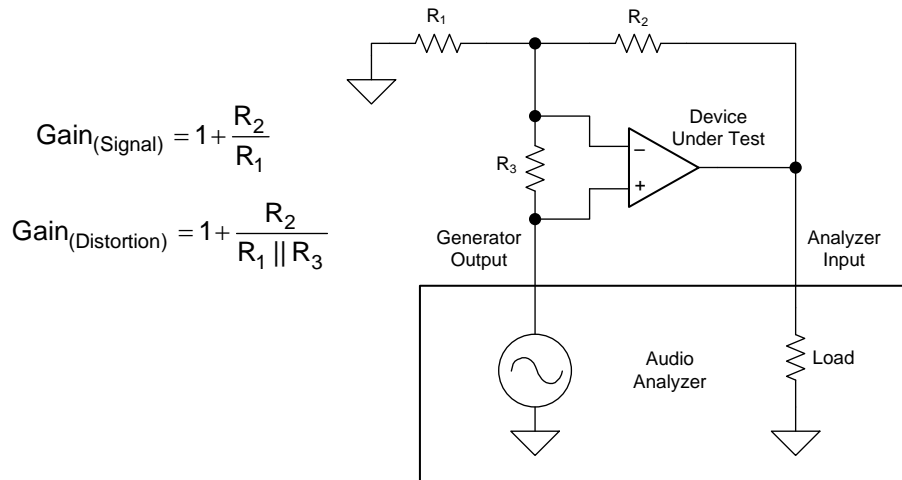
The low distortion and high output-current capabilities of the OPA1622 make this device an excellent choice for headphone-amplifier applications in portable or studio applications. These applications typically employ an audio digital-to-analog converter (DAC) and a separate headphone amplifier circuit connected to the DAC output. High-performance audio DACs can have an output signal that is either a varying current or voltage. Voltage output configurations require less external circuitry, and therefore have advantages in cost, power consumption, and solution size. However, these configurations can offer slightly lower performance than current output configurations. Differential outputs are standard on both types of DACs. Differential outputs double the output signal levels that can be delivered on a single, low-voltage supply, and also allow for even-harmonics common to both outputs to be cancelled by external circuitry. A simplified representation of a voltage-output audio DAC is shown in 图 52. Two ac voltage sources ( $V_{AC}$ ) deliver the output signal to the complementary outputs through their associated output impedances ( $R_{OUT}$ ). Both output signals have a dc component as well, represented by dc voltage source  $V_{DC}$ . The headphone amplifier circuit connected to the output of an audio DAC must convert the differential output into a single-ended signal and be capable of producing signals of sufficient amplitude at the headphones to achieve reasonable listening levels.



图 52. OPA1622 Used as a Headphone Amplifier for a Voltage-Output Audio DAC

### 8.2.1 Design Requirements

- $\pm 5$ -V power supplies
- 150-mW output power (32- $\Omega$  load)
- $< -115$ -dB THD+N at maximum output (32- $\Omega$  load)
- $< 0.01$ -dB magnitude deviation (20 Hz to 20 kHz)

### 8.2.2 Detailed Design Procedure

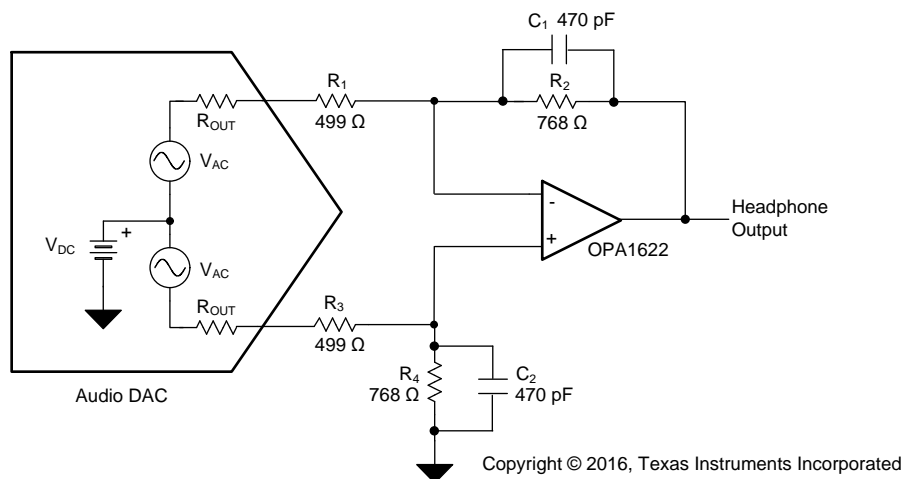
图 52 shows a schematic of a headphone amplifier circuit for voltage output DACs. An op amp is configured as a difference amplifier that converts the differential output voltage to single-ended. The values of the resistors in the difference amplifier circuit are determined by the specifications of the DAC, such as output voltage and output impedance, as well as the maximum output voltage desired at the headphone output. The op amp chosen must be capable of delivering the necessary current to the headphones and remain stable into typical headphone loads that can have capacitances as high as 400 pF. The following design process uses a hypothetical DAC with common values of output voltage and impedance for the design process. The specifications of the DAC are shown in 表 1:

表 1. Audio DAC Specifications Used for the Design Process

PARAMETER	VALUE
Maximum differential output voltage	2 $V_{RMS}$
Output impedance ( $R_{OUT}$ )	200 $\Omega$
Output dc offset	1.65 V

The gain of the difference amplifier in 图 52 is determined by the resistor values, and includes the output impedance of the DAC. For  $R_2 = R_4$  and  $R_1 = R_3$ , the output voltage of the headphone amplifier circuit is shown in 公式 5:

$$V_{OUT} = V_{DAC} \frac{R_2}{R_1 + R_{OUT}} \quad (5)$$

The output voltage required for headphones depends on the headphone impedance, as well as the headphone efficiency ( $\eta$ ), a measure of the sound pressure level (SPL, measured in dB) for a certain input power level (typically given at 1 mW). The headphone SPL at other power levels is calculated using 公式 6:

$$SPL(dB) = \eta + 10 \log \left( \frac{P_{IN}}{1 \text{ mW}} \right)$$

where

- $\eta$  = efficiency
  - $P_{IN}$  = input power to the headphones
- (6)

图 53 shows the input power required to produce certain SPLs for different headphone efficiencies. Typically, over-the-ear style headphones have lower efficiencies than in-ear types with 95 dB/mW being a common value.



图 53. Sound Pressure Level vs Input Power for Headphones of Various Efficiencies

In-ear headphones can have efficiencies of 115 dB/mW or greater, and therefore have much lower power requirements. The output power goal for this design is 150 mW; sufficient power to produce extremely loud sound pressure levels in a wide range of headphones. A 32-Ω headphone impedance is used for this requirement because 32 Ω is a very common value in headphones for portable applications. 公式 7 shows the voltage required for 32-Ω headphones:

$$V_O = \sqrt{P \times R} = \sqrt{150 \text{ mW} \times 32 \Omega} = 2.191 V_{RMS} \quad (7)$$

A tradeoff exists when selecting resistor values for this design. First, high resistor values contribute additional noise to the circuit, degrading the audio performance. However, extremely low resistor values draw excessive current from the DAC, increasing distortion. A value of 499 Ω is used for resistors  $R_1$  and  $R_3$  as a reasonable compromise between these two considerations. Resistor  $R_2$  and  $R_4$  can then be calculated as shown in 公式 8:

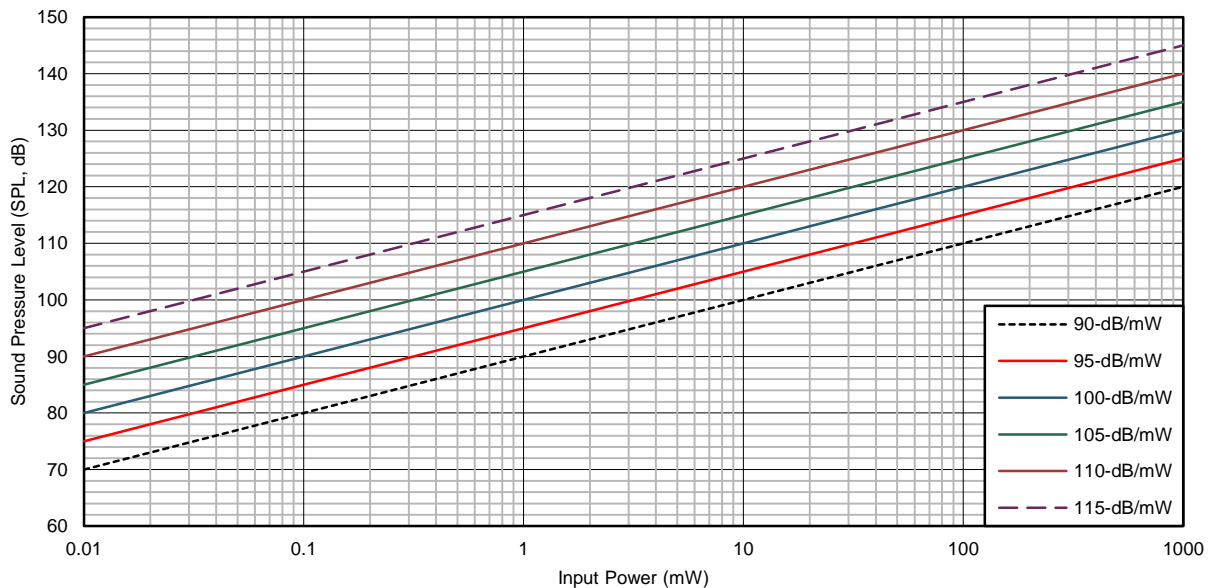
$$V_{OUT} = V_{DAC} \frac{R_2}{R_1 + R_{OUT}} \rightarrow 1.095 = \frac{R_2}{499 \Omega + 200 \Omega} \rightarrow R_2 = 765.4 \Omega \rightarrow 768 \Omega \quad (8)$$

In order to accommodate higher impedance headphones, increase the gain of the circuit to produce greater output voltages. However, increasing the gain also increases the noise of the circuit and limits the dynamic range of the circuit into lower impedance headphones. For this reason, some designers choose to select the headphone amplifier gain by using a switch.

Capacitors  $C_1$  and  $C_2$  limit the bandwidth of the circuit to prevent the unnecessary amplification of interfering signals. The maximum value of these capacitors is determined by the limitations on frequency response magnitude deviation detailed in the [Design Requirements](#) section.  $C_1$  and  $C_2$  combine with resistors  $R_2$  and  $R_4$  to form a pole, as shown in [公式 9](#):

$$f_p = \frac{1}{2\pi(R_2, R_4)(C_1, C_2)} \quad (9)$$

Calculate the minimum pole frequency allowable to meet the magnitude deviation requirements using [公式 10](#):

$$f_p \geq \frac{f}{\sqrt{\left(\frac{1}{G}\right)^2 - 1}} \geq \frac{20 \text{ kHz}}{\sqrt{\left(\frac{1}{0.999}\right)^2 - 1}} \geq 416.6 \text{ kHz}$$

where

- $G$  represents the gain in decimal for a  $-0.01$ -dB deviation at 20 kHz. (10)

Use [公式 11](#) to calculate the upper limit for the value of  $C_1$  and  $C_2$  in order to meet the goal for minimal magnitude deviation at 20 kHz.

$$C_1, C_2 \leq \frac{1}{2\pi(R_2, R_4)F_p} \leq \frac{1}{2\pi(768 \Omega)(416.6 \text{ kHz})} \leq 497 \text{ pF} \rightarrow 470 \text{ pF} \quad (11)$$

### 8.2.3 Application Curves

The circuit described in [图 52](#) is constructed using 0.1% tolerance thin-film resistors (0603 package) and surface-mount film capacitors. The performance of the circuit is measured using a high-performance audio analyzer and is displayed in [图 54](#) through [图 59](#). The maximum output power for three common headphone impedances is shown in [表 2](#)

**表 2. Maximum Output Power and THD+N Before Clipping for Common Headphone Impedances**

LOAD IMPEDANCE ( $\Omega$ )	MAXIMUM OUTPUT POWER BEFORE CLIPPING (mW)	THD+N AT MAXIMUM OUTPUT POWER (dB)
16	95	-114.2
32	150	-118.7
600	11.3	-119.4

The maximum output power delivered to low impedance headphone loads (16  $\Omega$  and 32  $\Omega$ ) is limited by the output current capabilities of the amplifier. For the 600- $\Omega$  case, the maximum power delivered is limited by the output voltage capability of the amplifier and depends greatly on the power-supply voltages used. [图 55](#) shows the maximum output voltage achievable for each load before the onset of clipping ( $\pm 5$ -V supplies), indicated by a sharp increase in distortion.

As more current is delivered by the output transistors of an amplifier, additional distortion is produced. At low frequencies, this distortion is corrected by the feedback loop of the amplifier. However, as the loop gain of the amplifier begins to decline at high frequencies, the overall distortion begins to climb. The unique output stage design of the OPA1622 greatly reduces the additional distortion at high frequency when delivering large currents, as shown in [图 56](#). High-ordered harmonics (above the 2nd and 3rd) are also kept to a minimal level at high output powers, as shown in [图 57](#) through [图 59](#).



图 54. Headphone Amplifier Transfer Function



图 55. THD+N vs Output Voltage for Headphone Loads

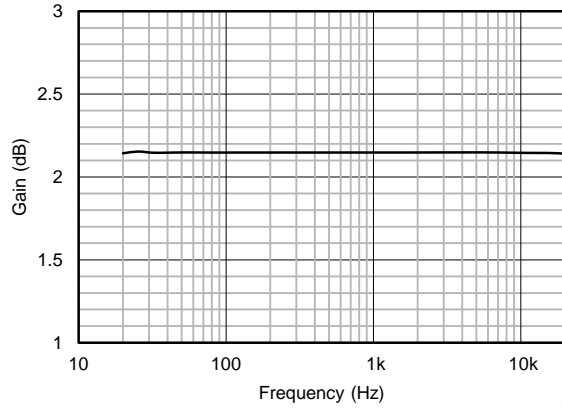

图 56. THD+N vs Frequency for Headphone Loads

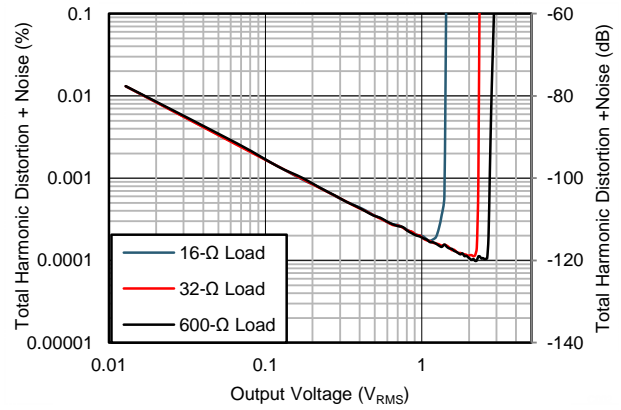

图 57. Output Spectrum

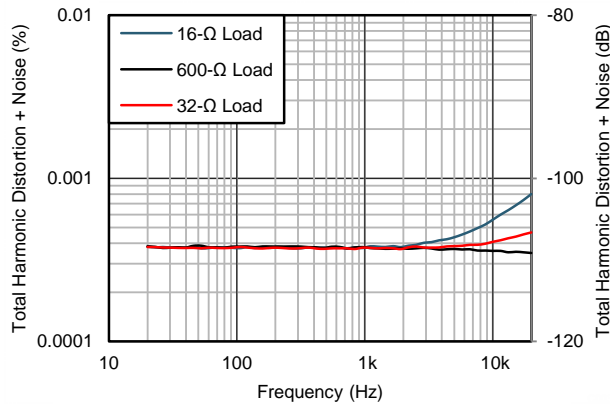

图 58. Output Spectrum

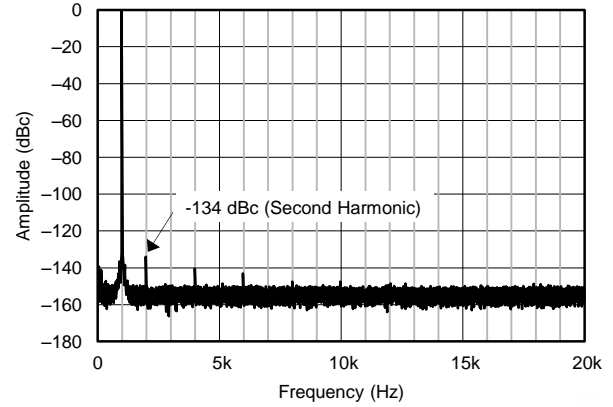

图 59. Output Spectrum

## 9 Power Supply Recommendations

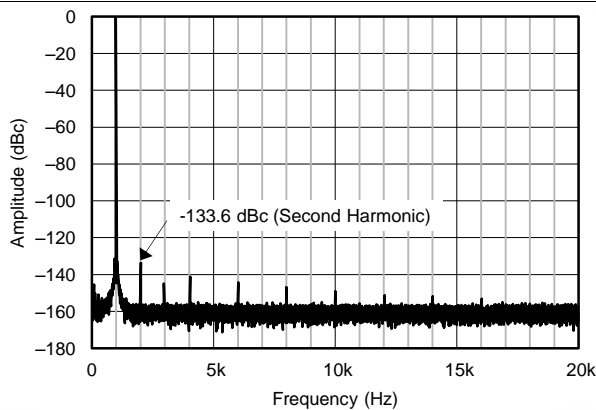
The OPA1622 op amp operates from  $\pm 2\text{-V}$  to  $\pm 18\text{-V}$  supplies, while maintaining excellent performance. However, some applications do not require equal positive and negative output voltage swing. With the OPA1622, power-supply voltages do not need to be equal. For example, the positive supply could be set to  $+25\text{ V}$  with the negative supply at  $-5\text{ V}$ .

In all cases, the common-mode voltage must be maintained within the specified range. Key parameters are specified over the temperature range of  $T_A = -40^\circ\text{C}$  to  $+125^\circ\text{C}$ . Parameters that vary with operating voltage or temperature are shown in the *Typical Characteristics* section.

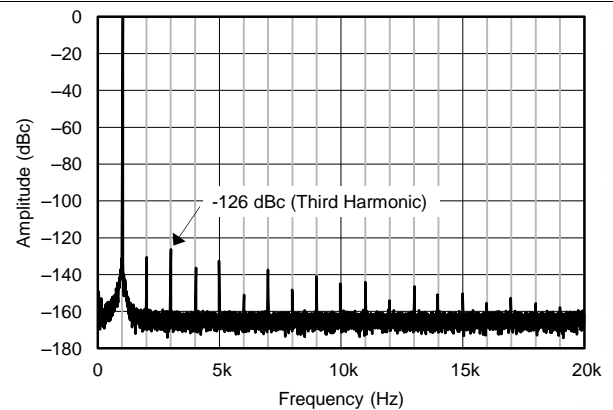
## 10 Layout

### 10.1 Layout Guidelines

For best operational performance of the device, use good printed circuit board (PCB) layout practices, including:

- Connect low-ESR,  $0.1\text{-}\mu\text{F}$  ceramic bypass capacitors between each supply pin and ground, placed as close to the device as possible. A single bypass capacitor from  $V+$  to ground is applicable for single-supply applications. The bypass capacitors are used to reduce the coupled noise by providing low-impedance power sources local to the analog circuitry, because noise can propagate into analog circuitry through the power pins of the circuit as a whole and the op amp specifically.
- Connect the IC ground pin to a low-impedance, low-noise, system reference point, such as an analog ground.
- Place the external components as close to the device as possible. As shown in [Figure 60](#), keep feedback resistors close to the inverting input to minimize parasitic capacitance and the feedback loop area.
- Keep the length of input traces as short as possible. Always remember that the input traces are the most sensitive part of the circuit.
- For proper amplifier function, connect the package thermal pad to the most negative supply voltage (VEE).

### 10.2 Layout Example

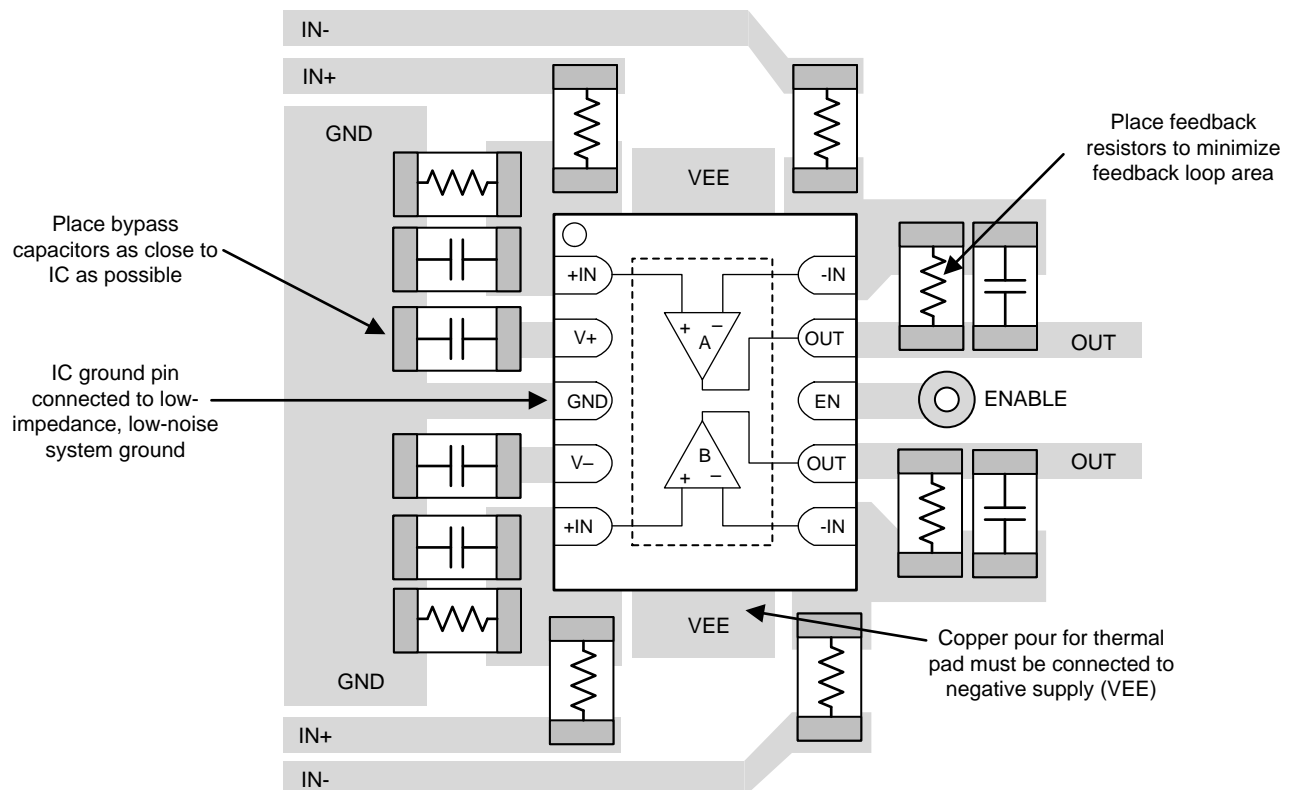

**图 60. Operational Amplifier Board Layout for a Difference Amplifier Configuration**

## 11 器件和文档支持

### 11.1 器件支持

#### 11.1.1 开发支持

##### 11.1.1.1 TINA-TI™ (免费下载)

TINA™是一款简单、功能强大且易于使用的电路仿真程序，此程序基于 SPICE 引擎。TINA-TI 是 TINA 软件的一款免费全功能版本，除了一系列无源和有源模型外，此版本软件还预先载入了一个宏模型库。TINA-TI 提供所有传统的 SPICE 直流、瞬态和频域分析，以及其他设计功能。

TINA-TI 可从 Analog eLab Design Center (模拟电子实验室设计中心) [免费下载](#)，它提供全面的后续处理能力，使得用户能够以多种方式形成结果。虚拟仪器提供选择输入波形和探测电路节点、电压和波形的功能，从而创建一个动态的快速入门工具。

---

#### 注

这些文件需要安装 TINA 软件 (由 DesignSoft™提供) 或者 TINA-TI 软件。请从 [TINA-TI 文件夹](#) 中下载免费的 TINA-TI 软件。

---

##### 11.1.1.2 TI 高精度设计

欲获取 TI 高精度设计，请访问 <http://www.ti.com.cn/ww/analog/precision-designs/>。TI 高精度设计是由 TI 公司高精度模拟应用专家创建的模拟解决方案，提供了许多实用电路的工作原理、组件选择、仿真、完整印刷电路板 (PCB) 电路原理图和布局布线、物料清单以及性能测量结果。

### 11.2 文档支持

#### 11.2.1 相关文章

相关文章如下：

- 《反馈曲线图定义运算放大器交流性能》，[SBOA015](#)
- 《电路板布局布线技巧》，[SLOA089](#)
- 《用于电压输出音频 DAC 的耳机放大器参考设计》，[TIDUAW1](#)
- 《面向耳机应用的差分放大器稳定化处理》，[SLYT630](#)
- 《降低 CMOS 模拟开关的失真度》，[SLYT612](#)

### 11.3 社区资源

The following links connect to TI community resources. Linked contents are provided "AS IS" by the respective contributors. They do not constitute TI specifications and do not necessarily reflect TI's views; see TI's [Terms of Use](#).

**TI E2E™ Online Community** *TI's Engineer-to-Engineer (E2E) Community*. Created to foster collaboration among engineers. At [e2e.ti.com](http://e2e.ti.com), you can ask questions, share knowledge, explore ideas and help solve problems with fellow engineers.

**Design Support** *TI's Design Support* Quickly find helpful E2E forums along with design support tools and contact information for technical support.

### 11.4 商标

SoundPlus, E2E are trademarks of Texas Instruments.

TINA-TI is a trademark of Texas Instruments, Inc and DesignSoft, Inc.

蓝光碟 is a trademark of Blu-ray Disc Association.

TINA, DesignSoft are trademarks of DesignSoft, Inc.

All other trademarks are the property of their respective owners.

## 11.5 静电放电警告



ESD 可能会损坏该集成电路。德州仪器 (TI) 建议通过适当的预防措施处理所有集成电路。如果不遵守正确的处理措施和安装程序，可能会损坏集成电路。

ESD 的损坏小至导致微小的性能降级，大至整个器件故障。精密的集成电路可能更容易受到损坏，这是因为非常细微的参数更改都可能会导致器件与其发布的规格不相符。

## 11.6 Glossary

[SLYZ022](#) — *TI Glossary*.

This glossary lists and explains terms, acronyms, and definitions.

## 12 机械、封装和可订购信息

以下页中包括机械、封装和可订购信息。这些信息是针对指定器件可提供的最新数据。这些数据会在无通知且不对本文档进行修订的情况下发生改变。欲获得该数据表的浏览器版本，请查阅左侧的导航栏。

## 重要声明

德州仪器(TI)及其下属子公司有权根据 JESD46 最新标准,对所提供的产品和服务进行更正、修改、增强、改进或其它更改,并有权根据 JESD48 最新标准中止提供任何产品和服务。客户在下订单前应获取最新的相关信息,并验证这些信息是否完整且是最新的。所有产品的销售都遵循在订单确认时所提供的TI 销售条款与条件。

TI 保证其所销售的组件的性能符合产品销售时 TI 半导体产品销售条件与条款的适用规范。仅在 TI 保证的范围内,且 TI 认为有必要时才会使用测试或其它质量控制技术。除非适用法律做出了硬性规定,否则没有必要对每种组件的所有参数进行测试。

TI 对应用帮助或客户产品设计不承担任何义务。客户应对其使用 TI 组件的产品和应用自行负责。为尽量减小与客户产品和应用相关的风险,客户应提供充分的设计与操作安全措施。

TI 不对任何 TI 专利权、版权、屏蔽作品权或其它与使用了 TI 组件或服务的组合设备、机器或流程相关的 TI 知识产权中授予的直接或隐含权限作出任何保证或解释。TI 所发布的与第三方产品或服务有关的信息,不能构成从 TI 获得使用这些产品或服务的许可、授权、或认可。使用此类信息可能需要获得第三方的专利权或其它知识产权方面的许可,或是 TI 的专利权或其它知识产权方面的许可。

对于 TI 的产品手册或数据表中 TI 信息的重要部分,仅在没有对内容进行任何篡改且带有相关授权、条件、限制和声明的情况下才允许进行复制。TI 对此类篡改过的文件不承担任何责任或义务。复制第三方的信息可能需要服从额外的限制条件。

在转售 TI 组件或服务时,如果对该组件或服务参数的陈述与 TI 标明的参数相比存在差异或虚假成分,则会失去相关 TI 组件或服务的所有明示或暗示授权,且这是不正当的、欺诈性商业行为。TI 对任何此类虚假陈述均不承担任何责任或义务。

客户认可并同意,尽管任何应用相关信息或支持仍可能由 TI 提供,但他们将独立负责满足与其产品及其在应用中使用的 TI 产品相关的所有法律、法规和安全相关要求。客户声明并同意,他们具备制定与实施安全措施所需的全部专业技术和知识,可预见故障的危险后果、监测故障及其后果、降低有可能造成人身伤害的故障的发生机率并采取适当的补救措施。客户将全额赔偿因在此类安全关键应用中使用任何 TI 组件而对 TI 及其代理造成的任何损失。

在某些场合中,为了推进安全相关应用有可能对 TI 组件进行特别的促销。TI 的目标是利用此类组件帮助客户设计和创立其特有的可满足适用的功能安全性标准和要求的终端产品解决方案。尽管如此,此类组件仍然服从这些条款。

TI 组件未获得用于 FDA Class III (或类似的生命攸关医疗设备)的授权许可,除非各方授权官员已经达成了专门管控此类使用的特别协议。

只有那些 TI 特别注明属于军用等级或“增强型塑料”的 TI 组件才是设计或专门用于军事/航空应用或环境的。购买者认可并同意,对并非指定面向军事或航空航天用途的 TI 组件进行军事或航空航天方面的应用,其风险由客户单独承担,并且由客户独立负责满足与此类使用相关的所有法律和法规要求。

TI 已明确指定符合 ISO/TS16949 要求的产品,这些产品主要用于汽车。在任何情况下,因使用非指定产品而无法达到 ISO/TS16949 要求, TI 不承担任何责任。

	产品		应用
数字音频	<a href="http://www.ti.com.cn/audio">www.ti.com.cn/audio</a>	通信与电信	<a href="http://www.ti.com.cn/telecom">www.ti.com.cn/telecom</a>
放大器和线性器件	<a href="http://www.ti.com.cn/amplifiers">www.ti.com.cn/amplifiers</a>	计算机及周边	<a href="http://www.ti.com.cn/computer">www.ti.com.cn/computer</a>
数据转换器	<a href="http://www.ti.com.cn/dataconverters">www.ti.com.cn/dataconverters</a>	消费电子	<a href="http://www.ti.com.cn/consumer-apps">www.ti.com.cn/consumer-apps</a>
DLP® 产品	<a href="http://www.dlp.com">www.dlp.com</a>	能源	<a href="http://www.ti.com.cn/energy">www.ti.com.cn/energy</a>
DSP - 数字信号处理器	<a href="http://www.ti.com.cn/dsp">www.ti.com.cn/dsp</a>	工业应用	<a href="http://www.ti.com.cn/industrial">www.ti.com.cn/industrial</a>
时钟和计时器	<a href="http://www.ti.com.cn/clockandtimers">www.ti.com.cn/clockandtimers</a>	医疗电子	<a href="http://www.ti.com.cn/medical">www.ti.com.cn/medical</a>
接口	<a href="http://www.ti.com.cn/interface">www.ti.com.cn/interface</a>	安防应用	<a href="http://www.ti.com.cn/security">www.ti.com.cn/security</a>
逻辑	<a href="http://www.ti.com.cn/logic">www.ti.com.cn/logic</a>	汽车电子	<a href="http://www.ti.com.cn/automotive">www.ti.com.cn/automotive</a>
电源管理	<a href="http://www.ti.com.cn/power">www.ti.com.cn/power</a>	视频和影像	<a href="http://www.ti.com.cn/video">www.ti.com.cn/video</a>
微控制器 (MCU)	<a href="http://www.ti.com.cn/microcontrollers">www.ti.com.cn/microcontrollers</a>		
RFID 系统	<a href="http://www.ti.com.cn/rfidsys">www.ti.com.cn/rfidsys</a>		
OMAP应用处理器	<a href="http://www.ti.com/omap">www.ti.com/omap</a>		
无线连通性	<a href="http://www.ti.com.cn/wirelessconnectivity">www.ti.com.cn/wirelessconnectivity</a>	德州仪器在线技术支持社区	<a href="http://www.deyisupport.com">www.deyisupport.com</a>

邮寄地址: 上海市浦东新区世纪大道1568号, 中建大厦32楼邮政编码: 200122  
Copyright © 2016, 德州仪器半导体技术(上海)有限公司

**PACKAGING INFORMATION**

Orderable Device	Status (1)	Package Type	Package Drawing	Pins	Package Qty	Eco Plan (2)	Lead finish/ Ball material (6)	MSL Peak Temp (3)	Op Temp (°C)	Device Marking (4/5)	Samples
OPA1622IDRCR	ACTIVE	VSON	DRC	10	3000	RoHS & Green	NIPDAU	Level-2-260C-1 YEAR	-40 to 125	O1622	<a href="#">Samples</a>
OPA1622IDRCT	ACTIVE	VSON	DRC	10	250	RoHS & Green	NIPDAU	Level-2-260C-1 YEAR	-40 to 125	O1622	<a href="#">Samples</a>

(1) The marketing status values are defined as follows:

**ACTIVE:** Product device recommended for new designs.

**LIFEBUY:** TI has announced that the device will be discontinued, and a lifetime-buy period is in effect.

**NRND:** Not recommended for new designs. Device is in production to support existing customers, but TI does not recommend using this part in a new design.

**PREVIEW:** Device has been announced but is not in production. Samples may or may not be available.

**OBSOLETE:** TI has discontinued the production of the device.

(2) **RoHS:** TI defines "RoHS" to mean semiconductor products that are compliant with the current EU RoHS requirements for all 10 RoHS substances, including the requirement that RoHS substance do not exceed 0.1% by weight in homogeneous materials. Where designed to be soldered at high temperatures, "RoHS" products are suitable for use in specified lead-free processes. TI may reference these types of products as "Pb-Free".

**RoHS Exempt:** TI defines "RoHS Exempt" to mean products that contain lead but are compliant with EU RoHS pursuant to a specific EU RoHS exemption.

**Green:** TI defines "Green" to mean the content of Chlorine (Cl) and Bromine (Br) based flame retardants meet JS709B low halogen requirements of <=1000ppm threshold. Antimony trioxide based flame retardants must also meet the <=1000ppm threshold requirement.

(3) MSL, Peak Temp. - The Moisture Sensitivity Level rating according to the JEDEC industry standard classifications, and peak solder temperature.

(4) There may be additional marking, which relates to the logo, the lot trace code information, or the environmental category on the device.

(5) Multiple Device Markings will be inside parentheses. Only one Device Marking contained in parentheses and separated by a "~" will appear on a device. If a line is indented then it is a continuation of the previous line and the two combined represent the entire Device Marking for that device.

(6) Lead finish/Ball material - Orderable Devices may have multiple material finish options. Finish options are separated by a vertical ruled line. Lead finish/Ball material values may wrap to two lines if the finish value exceeds the maximum column width.

**Important Information and Disclaimer:**The information provided on this page represents TI's knowledge and belief as of the date that it is provided. TI bases its knowledge and belief on information provided by third parties, and makes no representation or warranty as to the accuracy of such information. Efforts are underway to better integrate information from third parties. TI has taken and continues to take reasonable steps to provide representative and accurate information but may not have conducted destructive testing or chemical analysis on incoming materials and chemicals. TI and TI suppliers consider certain information to be proprietary, and thus CAS numbers and other limited information may not be available for release.

In no event shall TI's liability arising out of such information exceed the total purchase price of the TI part(s) at issue in this document sold by TI to Customer on an annual basis.



**TAPE AND REEL INFORMATION**

**QUADRANT ASSIGNMENTS FOR PIN 1 ORIENTATION IN TAPE**

\*All dimensions are nominal

Device	Package Type	Package Drawing	Pins	SPQ	Reel Diameter (mm)	Reel Width W1 (mm)	A0 (mm)	B0 (mm)	K0 (mm)	P1 (mm)	W (mm)	Pin1 Quadrant
OPA1622IDRCR	VSON	DRC	10	3000	330.0	12.4	3.3	3.3	1.1	8.0	12.0	Q2
OPA1622IDRCT	VSON	DRC	10	250	180.0	12.4	3.3	3.3	1.1	8.0	12.0	Q2

**TAPE AND REEL BOX DIMENSIONS**

\*All dimensions are nominal

Device	Package Type	Package Drawing	Pins	SPQ	Length (mm)	Width (mm)	Height (mm)
OPA1622IDRCR	VSON	DRC	10	3000	367.0	367.0	35.0
OPA1622IDRCT	VSON	DRC	10	250	210.0	185.0	35.0

## GENERIC PACKAGE VIEW

**DRC 10**

**VSON - 1 mm max height**

3 x 3, 0.5 mm pitch

PLASTIC SMALL OUTLINE - NO LEAD

This image is a representation of the package family, actual package may vary.  
Refer to the product data sheet for package details.

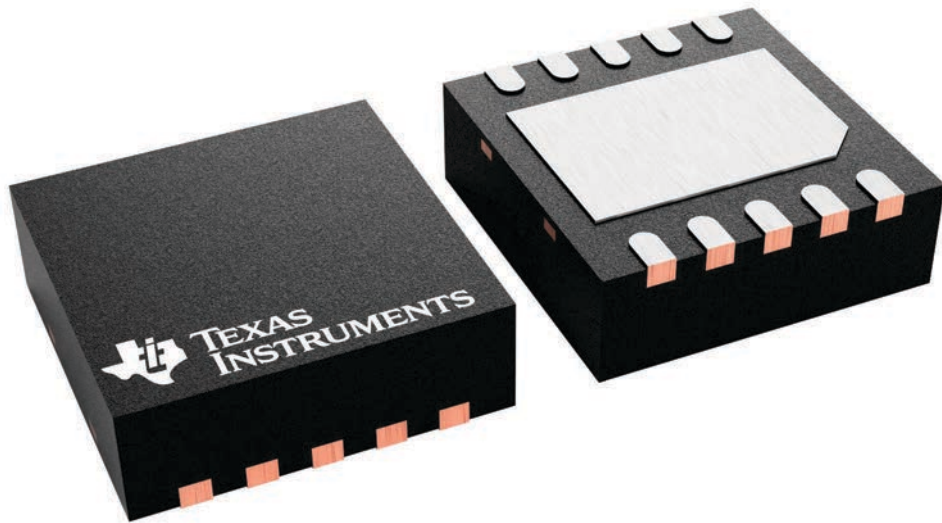

4226193/A



# EXAMPLE BOARD LAYOUT

DRC0010J

VSON - 1 mm max height

PLASTIC SMALL OUTLINE - NO LEAD

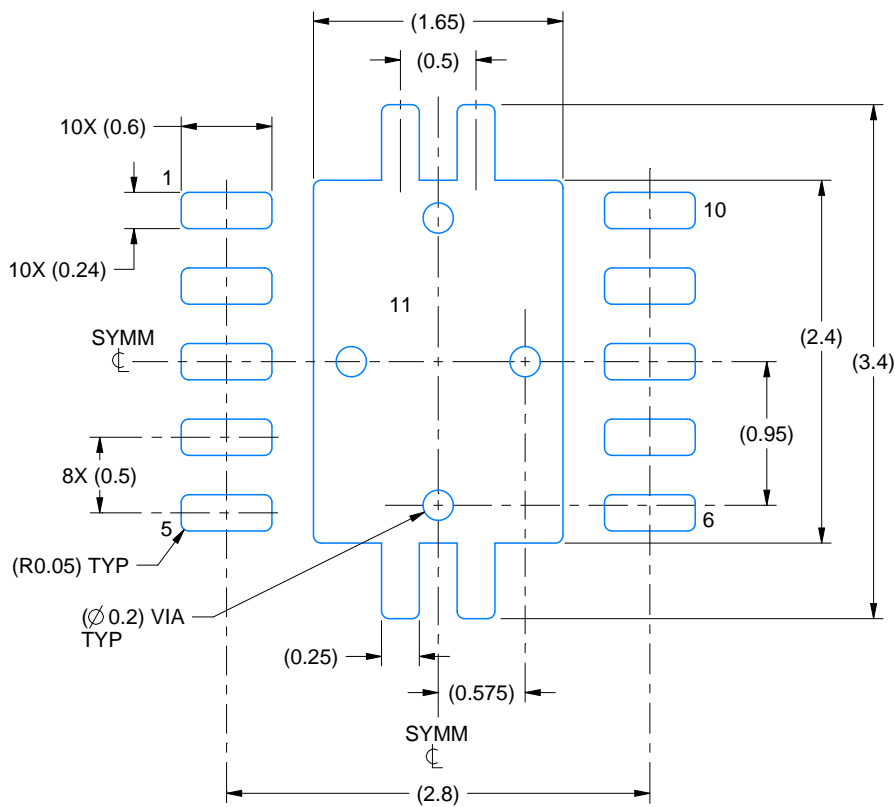

LAND PATTERN EXAMPLE  
EXPOSED METAL SHOWN  
SCALE:20X

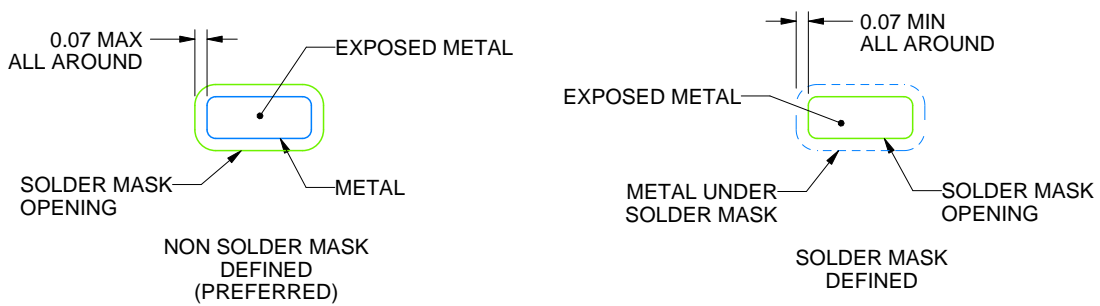

SOLDER MASK DETAILS

4218878/B 07/2018

NOTES: (continued)

4. This package is designed to be soldered to a thermal pad on the board. For more information, see Texas Instruments literature number SLUA271 ([www.ti.com/lit/sluea271](http://www.ti.com/lit/sluea271)).
5. Vias are optional depending on application, refer to device data sheet. If any vias are implemented, refer to their locations shown on this view. It is recommended that vias under paste be filled, plugged or tented.

# EXAMPLE STENCIL DESIGN

DRC0010J

VSON - 1 mm max height

PLASTIC SMALL OUTLINE - NO LEAD

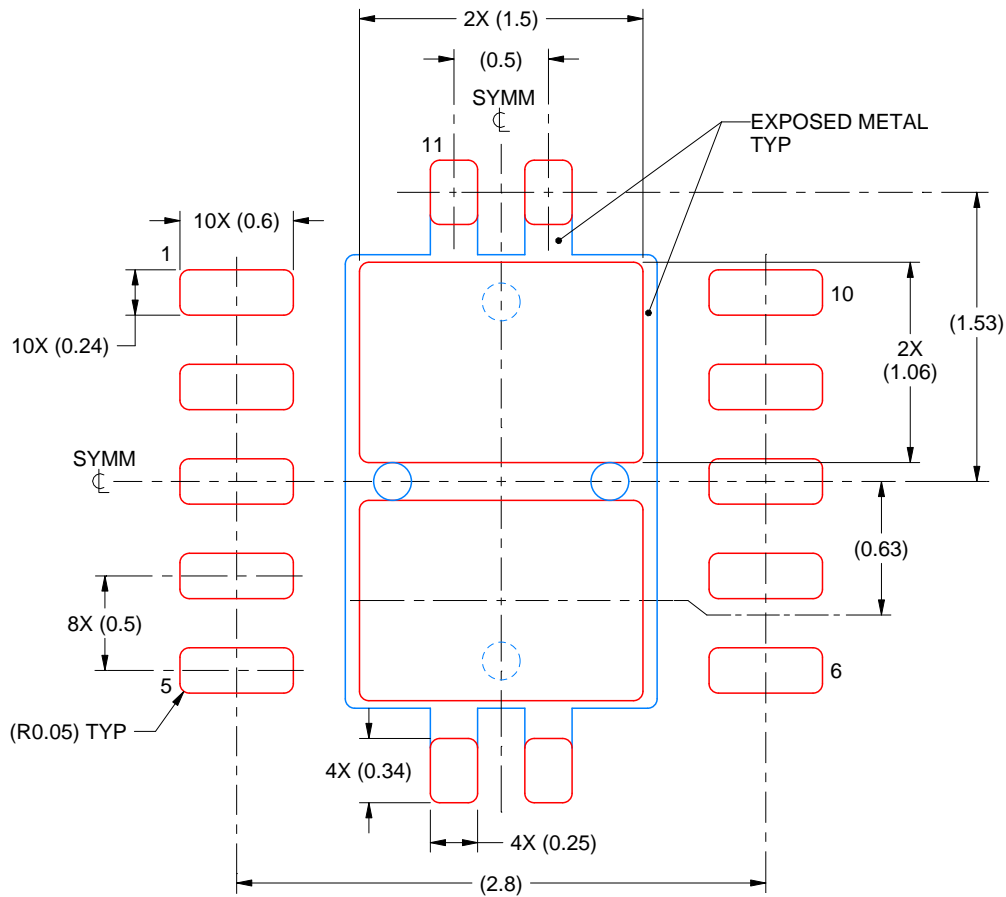

SOLDER PASTE EXAMPLE  
BASED ON 0.125 mm THICK STENCIL

EXPOSED PAD 11:  
80% PRINTED SOLDER COVERAGE BY AREA  
SCALE:25X

4218878/B 07/2018

NOTES: (continued)

6. Laser cutting apertures with trapezoidal walls and rounded corners may offer better paste release. IPC-7525 may have alternate design recommendations.

## 重要声明和免责声明

TI 均以“原样”提供技术性及其可靠性数据（包括数据表）、设计资源（包括参考设计）、应用或其他设计建议、网络工具、安全信息和其他资源，不保证其中不含任何瑕疵，且不做任何明示或暗示的担保，包括但不限于对适销性、适合某特定用途或不侵犯任何第三方知识产权的暗示担保。

所述资源可供专业开发人员应用TI 产品进行设计使用。您将对以下行为独自承担全部责任：(1) 针对您的应用选择合适的TI 产品；(2) 设计、验证并测试您的应用；(3) 确保您的应用满足相应标准以及任何其他安全、安保或其他要求。所述资源如有变更，恕不另行通知。TI 对您使用所述资源的授权仅限于开发资源所涉及TI 产品的相关应用。除此之外不得复制或展示所述资源，也不提供其它TI 或任何第三方的知识产权授权许可。如因使用所述资源而产生任何索赔、赔偿、成本、损失及债务等，TI 对此概不负责，并且您须赔偿由此对TI 及其代表造成的损害。

TI 所提供产品均受TI 的销售条款 (<http://www.ti.com.cn/zh-cn/legal/termsofsale.html>) 以及ti.com.cn上或随附TI产品提供的其他可适用条款的约束。TI提供所述资源并不扩展或以其他方式更改TI 针对TI 产品所发布的可适用的担保范围或担保免责声明。

邮寄地址：上海市浦东新区世纪大道 1568 号中建大厦 32 楼，邮政编码：200122

Copyright © 2020 德州仪器半导体技术（上海）有限公司