

OPA859-Q1 1.8GHz 单位带宽增益积、 $3.3\text{nV}/\sqrt{\text{Hz}}$ FET 输入放大器

1 特性

- 符合面向汽车应用的 AEC-Q100 标准：
 - 温度等级 1：-40°C 至 +125°C， T_A
- 高单位带宽增益积：1.8GHz
- 增益带宽积：900MHz
- 超低偏置电流 MOSFET 输入：10pA
- 低输入电压噪声： $3.3\text{nV}/\sqrt{\text{Hz}}$
- 压摆率：1150V/ μs
- 低输入电容：
 - 共模：0.6pF
 - 差动：0.2pF
- 宽输入共模范围：
 - 与正电源相差 1.4V
 - 包括负电源
- TIA 配置下的输出摆幅为 2.5V_{PP}
- 电源电压范围：3.3V 至 5.25V
- 静态电流：20.5mA
- 封装：8 引脚 WSON
- 温度范围：-40°C 至 +125°C

2 应用

- 汽车激光雷达
- 飞行时间 (ToF) 摄像头
- 光学时域反射法 (OTDR)
- 3D 扫描仪
- 激光测距
- 固态扫描激光雷达
- 光学 ToF 位置传感器
- 无人机视觉
- 硅光电倍增器 (SiPM) 缓冲放大器
- 光电倍增管后置放大器

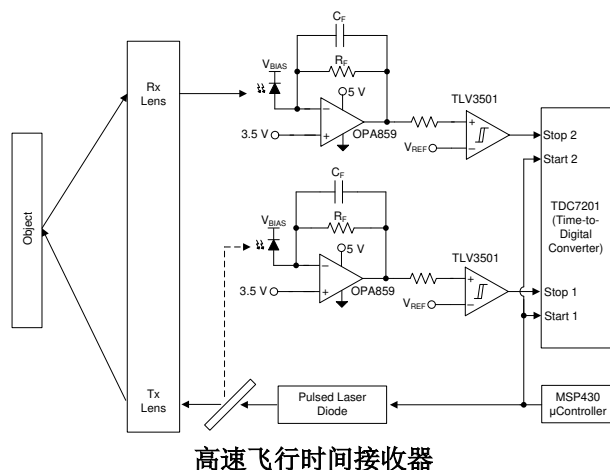

3 说明

OPA859-Q1 是一款具有 CMOS 输入的宽带低噪声运算放大器，适用于宽带跨阻和电压放大器应用。将该器件配置为跨阻放大器 (TIA) 时，0.9GHz 增益带宽积 (GBWP) 能够在低电容光电二极管应用中实现高闭环带宽。

下图展示了当将 OPA859-Q1 配置为 TIA 时，该放大器的带宽和噪声性能与光电二极管电容的函数关系。计算总噪声时的带宽范围为从直流到左轴上计算得出的频率 (f)。OPA859-Q1 封装具有一个反馈引脚 (FB)，可简化输入和输出之间的反馈网络连接。

OPA859-Q1 经过优化，可在光学飞行时间 (ToF) 系统中运行，在该系统中，OPA859-Q1 与时数转换器 (如 TDC7201) 配合使用。可在具有差分输出放大器 (如 THS4541-Q1) 的高分辨率激光雷达系统中使用 OPA859-Q1 来驱动高速模数转换器 (ADC)。

器件信息

器件型号 ⁽¹⁾	封装	封装尺寸 (标称值)
OPA859-Q1	WSON (8)	2.00 mm × 2.00 mm

(1) 如需了解所有可用封装，请参阅数据表末尾的封装选项附录。

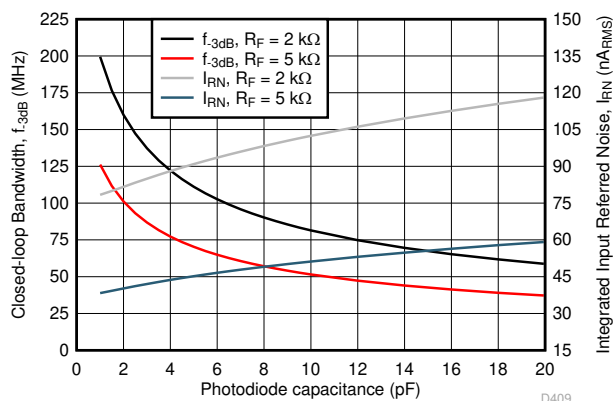

Table of Contents

1 特性	1	9 Application and Implementation	21
2 应用	1	9.1 Application Information.....	21
3 说明	1	9.2 Typical Application.....	21
4 Revision History	2	10 Power Supply Recommendations	23
5 Pin Configuration and Functions	4	11 Layout	24
6 Specifications	5	11.1 Layout Guidelines.....	24
6.1 Absolute Maximum Ratings	5	11.2 Layout Example.....	24
6.2 ESD Ratings	5	12 Device and Documentation Support	25
6.3 Recommended Operating Conditions	5	12.1 Device Support.....	25
6.4 Thermal Information	5	12.2 Documentation Support.....	25
6.5 Electrical Characteristics	6	12.3 Receiving Notification of Documentation Updates..	25
6.6 Typical Characteristics.....	8	12.4 支持资源.....	25
7 Parameter Measurement Information	15	12.5 Trademarks.....	25
8 Detailed Description	16	12.6 静电放电警告.....	25
8.1 Overview.....	16	12.7 术语表.....	25
8.2 Functional Block Diagram.....	16	13 Mechanical, Packaging, and Orderable	
8.3 Feature Description.....	17	Information	25
8.4 Device Functional Modes.....	20		

4 Revision History

注：以前版本的页码可能与当前版本的页码不同

DATE	REVISION	NOTES
February 2021	*	Initial Release

Device Comparison Table

DEVICE	INPUT TYPE	MINIMUM STABLE GAIN	VOLTAGE NOISE (nV/\sqrt{Hz})	INPUT CAPACITANCE (pF)	GAIN BANDWIDTH (GHz)
OPA855-Q1	Bipolar	7 V/V	0.98	0.8	8
OPA858-Q1	CMOS	7 V/V	2.5	0.8	5.5
OPA859-Q1	CMOS	1 V/V	3.3	0.8	0.9

5 Pin Configuration and Functions

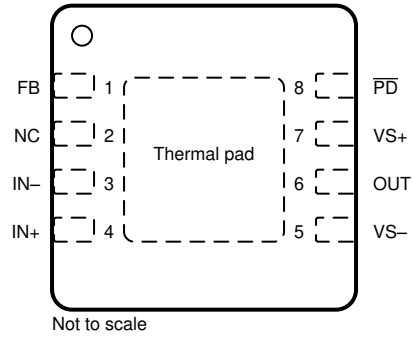

**图 5-1. DSG Package
8-Pin WSON With Exposed Thermal Pad
Top View**

表 5-1. Pin Functions

PIN		I/O	DESCRIPTION
NAME	NO.		
FB	1	I	Feedback connection to output of amplifier
IN -	3	I	Inverting input
IN+	4	I	Noninverting input
NC	2	—	Do not connect
OUT	6	O	Amplifier output
PD	8	I	Power down connection. $\overline{\text{PD}}$ = logic low = power off mode; PD = logic high = normal operation.
VS -	5	—	Negative voltage supply
VS+	7	—	Positive voltage supply
Thermal pad		—	Connect the thermal pad to VS -

6 Specifications

6.1 Absolute Maximum Ratings

over operating free-air temperature range (unless otherwise noted)⁽¹⁾

		MIN	MAX	UNIT
V _S	Total supply voltage (V _{S+} - V _{S-})		5.5	V
V _{IN+} , V _{IN-}	Input voltage	(V _{S-}) - 0.5	(V _{S+}) + 0.5	V
V _{ID}	Differential input voltage		1	V
V _{OUT}	Output voltage	(V _{S-}) - 0.5	(V _{S+}) + 0.5	V
I _{IN}	Continuous input current		±10	mA
I _{OUT}	Continuous output current ⁽²⁾		±100	mA
T _J	Junction temperature		150	°C
T _A	Operating free-air temperature	- 40	125	°C
T _{stg}	Storage temperature	- 65	150	°C

- (1) Stresses beyond those listed under *Absolute Maximum Rating* may cause permanent damage to the device. These are stress ratings only, which do not imply functional operation of the device at these or any other conditions beyond those indicated under *Recommended Operating Condition*. Exposure to absolute-maximum-rated conditions for extended periods may affect device reliability.
- (2) Long-term continuous output current for electromigration limits.

6.2 ESD Ratings

			VALUE	UNIT
V _(ESD)	Electrostatic discharge	Human-body model (HBM), per AEC Q100-002 ⁽¹⁾	± 1500	V
		Charged-device model (CDM), per AEC Q100-011	±1000	

- (1) AEC Q100-002 indicates that HBM stressing shall be in accordance with the ANSI/ESDA/JEDEC JS-001 specification.

6.3 Recommended Operating Conditions

over operating free-air temperature range (unless otherwise noted)

		MIN	NOM	MAX	UNIT
V _S	Total supply voltage (V _{S+} - V _{S-})	3.3	5	5.25	V
T _A	Operating free-air temperature	- 40		125	°C

6.4 Thermal Information

THERMAL METRIC ⁽¹⁾		OPA859-Q1	UNIT
		DSG (WSON)	
		8 PINS	
R _{θJA}	Junction-to-ambient thermal resistance	80.1	°C/W
R _{θJC(top)}	Junction-to-case (top) thermal resistance	100	°C/W
R _{θJB}	Junction-to-board thermal resistance	45	°C/W
Ψ _{JT}	Junction-to-top characterization parameter	6.8	°C/W
Ψ _{JB}	Junction-to-board characterization parameter	45.2	°C/W
R _{θJC(bot)}	Junction-to-case (bottom) thermal resistance	22.7	°C/W

- (1) For more information about traditional and new thermal metrics, see the [Semiconductor and IC Package Thermal Metrics](#) application report.

6.5 Electrical Characteristics

$V_{S+} = 5\text{ V}$, $V_{S-} = 0\text{ V}$, input common-mode biased at midsupply, unity gain configuration, $R_L = 200\ \Omega$, output load is referenced to midsupply, and $T_A \approx +25^\circ\text{C}$ (unless otherwise noted)

PARAMETER		TEST CONDITIONS	MIN	TYP	MAX	UNIT
AC PERFORMANCE						
SSBW	Small-signal bandwidth	$V_{OUT} = 100\text{ mV}_{PP}$		1.8		GHz
LSBW	Large-signal bandwidth	$V_{OUT} = 2\text{ V}_{PP}$		400		MHz
GBWP	Gain-bandwidth product			900		MHz
	Bandwidth for 0.1dB flatness			140		MHz
SR	Slew rate (10% - 90%)	$V_{OUT} = 2\text{-V step}$		1150		V/ μs
t_r	Rise time	$V_{OUT} = 100\text{-mV step}$		0.3		ns
t_f	Fall time	$V_{OUT} = 100\text{-mV step}$		0.3		ns
	Settling time to 0.1%	$V_{OUT} = 2\text{-V step}$		8		ns
	Settling time to 0.001%	$V_{OUT} = 2\text{-V step}$		3000		ns
	Overshoot/undershoot	$V_{OUT} = 2\text{-V step}$		7%		
HD2	Second-order harmonic distortion	$f = 10\text{ MHz}$, $V_{OUT} = 2\text{ V}_{PP}$		90		dBc
		$f = 100\text{ MHz}$, $V_{OUT} = 2\text{ V}_{PP}$		60		
HD3	Third-order harmonic distortion	$f = 10\text{ MHz}$, $V_{OUT} = 2\text{ V}_{PP}$		86		dBc
		$f = 100\text{ MHz}$, $V_{OUT} = 2\text{ V}_{PP}$		64		
e_n	Input-referred voltage noise	$f = 1\text{ MHz}$		3.3		nV/ $\sqrt{\text{Hz}}$
Z_{OUT}	Closed-loop output impedance	$f = 1\text{ MHz}$		0.15		Ω
DC PERFORMANCE						
A_{OL}	Open-loop voltage gain		60	65		dB
V_{OS}	Input offset voltage	$T_A = 25^\circ\text{C}$	-5	± 0.9	5	mV
$\Delta V_{OS}/\Delta T$	Input offset voltage drift	$T_A = -40^\circ\text{C to } +125^\circ\text{C}$		-2		$\mu\text{V}/^\circ\text{C}$
I_{BN} , I_{BI}	Input bias current	$T_A = 25^\circ\text{C}$	-5	± 0.5	5	pA
I_{BOS}	Input offset current	$T_A = 25^\circ\text{C}$	-5	± 0.1	5	pA
CMRR	Common-mode rejection ratio	$V_{CM} = \pm 0.5\text{ V}$	70	84		dB
INPUT						
	Common-mode input resistance			1		G Ω
C_{CM}	Common-mode input capacitance			0.62		pF
	Differential input resistance			1		G Ω
C_{DIFF}	Differential input capacitance			0.2		pF
V_{IH}	Common-mode input range (high)	$V_{S+} = 3.3\text{ V}$, CMRR > 66 dB	1.7	1.9		V
V_{IL}	Common-mode input range (low)	$V_{S+} = 3.3\text{ V}$, CMRR > 66 dB		0	0.4	V
V_{IH}	Common-mode input range (high)	CMRR > 66 dB	3.4	3.6		V
		$T_A = -40^\circ\text{C to } +125^\circ\text{C}$, CMRR > 66 dB		3.3		
V_{IL}	Common-mode input range (low)	CMRR > 66 dB		0	0.4	V
		$T_A = -40^\circ\text{C to } +125^\circ\text{C}$, CMRR > 66 dB		0.35	0.45	
OUTPUT						
V_{OH}	Output voltage (high)	$V_{S+} = 3.3\text{ V}$, $T_A = 25^\circ\text{C}$	2.3	2.4		V
V_{OH}	Output voltage (high)	$T_A = 25^\circ\text{C}$	3.95	4.1		V
		$T_A = -40^\circ\text{C to } +125^\circ\text{C}$		3.9		
V_{OL}	Output voltage (low)	$V_{S+} = 3.3\text{ V}$, $T_A = 25^\circ\text{C}$		1.05	1.15	V
V_{OL}	Output voltage (low)	$T_A = 25^\circ\text{C}$		1.1	1.15	V
		$T_A = -40^\circ\text{C to } +125^\circ\text{C}$		1.2		

6.5 Electrical Characteristics (continued)

$V_{S+} = 5\text{ V}$, $V_{S-} = 0\text{ V}$, input common-mode biased at midsupply, unity gain configuration, $R_L = 200\ \Omega$, output load is referenced to midsupply, and $T_A \approx +25^\circ\text{C}$ (unless otherwise noted)

PARAMETER		TEST CONDITIONS	MIN	TYP	MAX	UNIT
I_{O_LIN}	Linear output drive (sink and source)	$R_L = 10\ \Omega$, $A_{OL} > 52\text{ dB}$	65	76		mA
		$T_A = -40^\circ\text{C}$ to $+125^\circ\text{C}$, $R_L = 10\ \Omega$, $A_{OL} > 52\text{ dB}$		64		
I_{SC}	Output short-circuit current		85	105		mA
POWER SUPPLY						
I_Q	Quiescent current	$V_{S+} = 5\text{ V}$	18	20.5	24	mA
		$V_{S+} = 3.3\text{ V}$	17.5	20	23.5	
		$V_{S+} = 5.25\text{ V}$	18	21	24	
		$T_A = 125^\circ\text{C}$		24.5		
		$T_A = -40^\circ\text{C}$		18.5		
PSRR+	Positive power-supply rejection ratio		66	74		dB
PSRR-	Negative power-supply rejection ratio		64	72		
POWER DOWN						
	Disable voltage threshold	Amplifier OFF below this voltage	0.65	1		V
	Enable voltage threshold	Amplifier ON above this voltage		1.5	1.8	V
	Power-down quiescent current			70	140	μA
	$\overline{\text{PD}}$ bias current			70	200	μA
	Turnon time delay	Time to $V_{OUT} = 90\%$ of final value		25		ns
	Turnoff time delay			120		ns

6.6 Typical Characteristics

at $T_A = 25^\circ\text{C}$, $V_{S+} = 2.5\text{ V}$, $V_{S-} = -2.5\text{ V}$, $V_{IN+} = 0\text{ V}$, Gain = 1 V/V, $R_F = 0\ \Omega$, $R_L = 200\ \Omega$, and output load referenced to midsupply (unless otherwise noted)

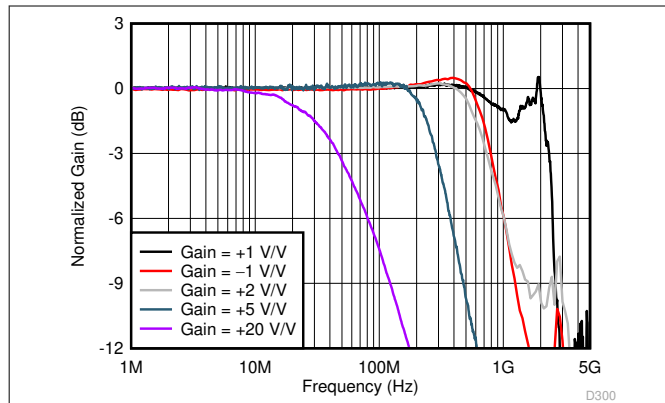

$V_{OUT} = 100\text{ mV}_{PP}$; see 节 7 for circuit configuration

图 6-1. Small-Signal Frequency Response vs Gain

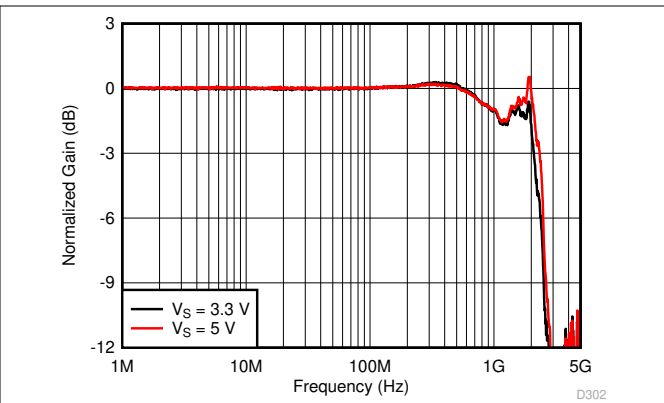

$V_{OUT} = 100\text{ mV}_{PP}$

图 6-2. Small-Signal Frequency Response vs Supply Voltage

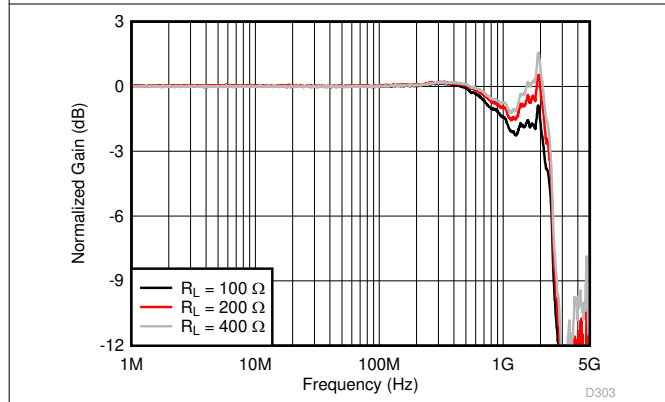

$V_{OUT} = 100\text{ mV}_{PP}$

图 6-3. Small-Signal Frequency Response vs Output Load

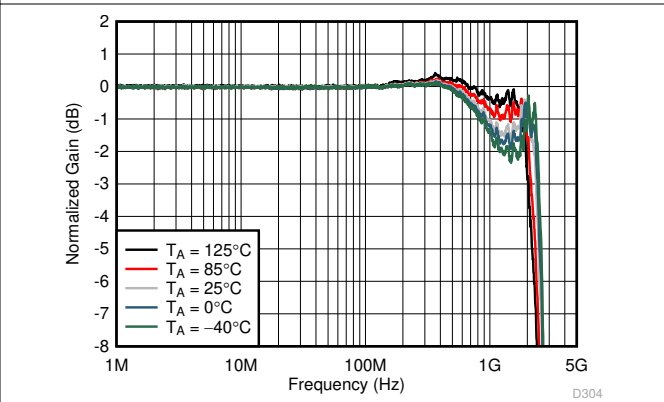

$V_{OUT} = 100\text{ mV}_{PP}$

图 6-4. Small-Signal Frequency Response vs Ambient Temperature

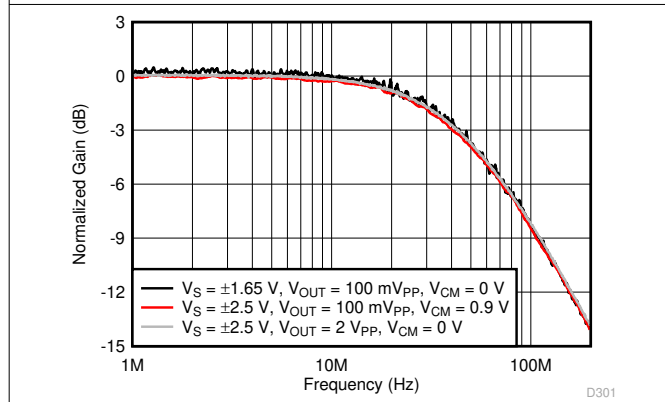

Gain = 20 V/V $R_F = 453\ \Omega$

图 6-5. Frequency Response at Gain = 20 V/V

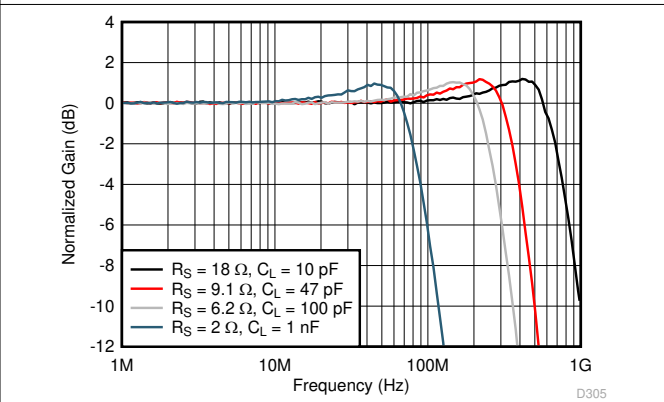

$V_{OUT} = 100\text{ mV}_{PP}$, See 图 7-4 for circuit configuration

图 6-6. Small-Signal Frequency Response vs Capacitive Load

6.6 Typical Characteristics (continued)

at $T_A = 25^\circ\text{C}$, $V_{S+} = 2.5\text{ V}$, $V_{S-} = -2.5\text{ V}$, $V_{IN+} = 0\text{ V}$, Gain = 1 V/V, $R_F = 0\ \Omega$, $R_L = 200\ \Omega$, and output load referenced to midsupply (unless otherwise noted)



图 6-7. Large-Signal Frequency Response vs Gain



图 6-8. Large-Signal Response for 0.1-dB Gain Flatness

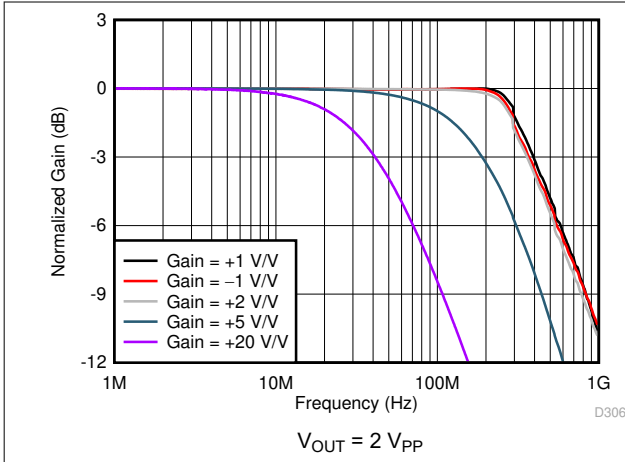

图 6-9. Closed-Loop Output Impedance vs Frequency

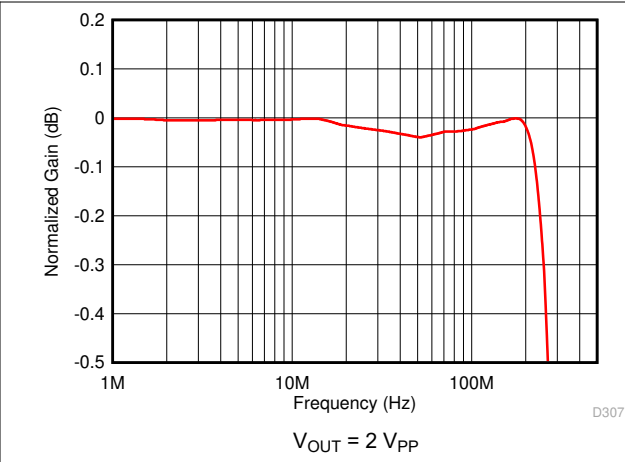

图 6-10. Open-Loop Magnitude and Phase vs Frequency

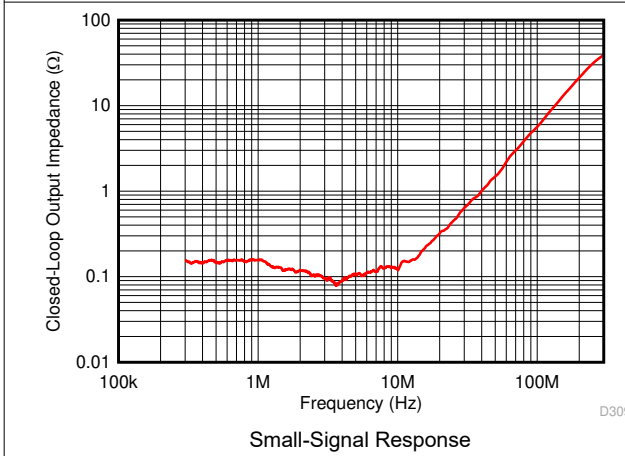

图 6-11. Voltage Noise Density vs Frequency

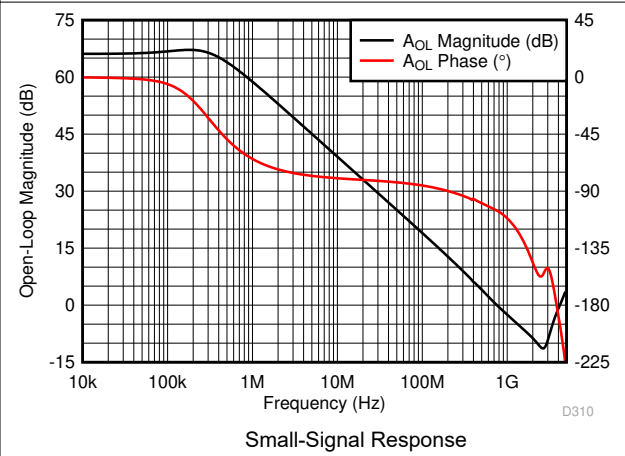

图 6-12. Voltage Noise Density vs Ambient Temperature

6.6 Typical Characteristics (continued)

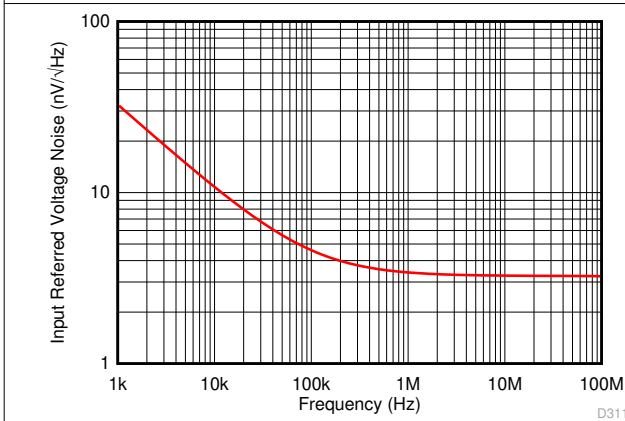
at $T_A = 25^\circ\text{C}$, $V_{S+} = 2.5\text{ V}$, $V_{S-} = -2.5\text{ V}$, $V_{IN+} = 0\text{ V}$, Gain = 1 V/V, $R_F = 0\ \Omega$, $R_L = 200\ \Omega$, and output load referenced to midsupply (unless otherwise noted)

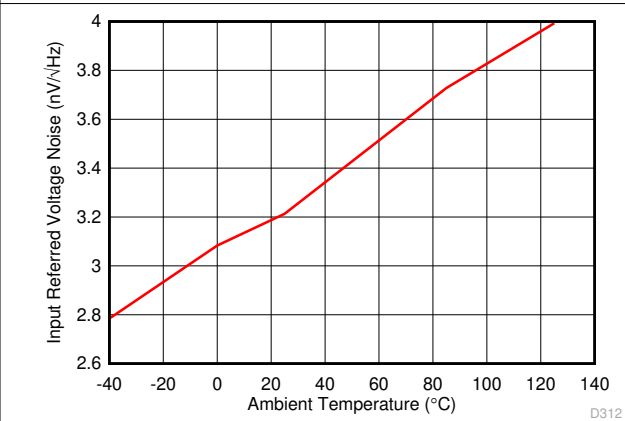

图 6-13. Harmonic Distortion (HD2) vs Output Swing



图 6-14. Harmonic Distortion (HD3) vs Output Swing

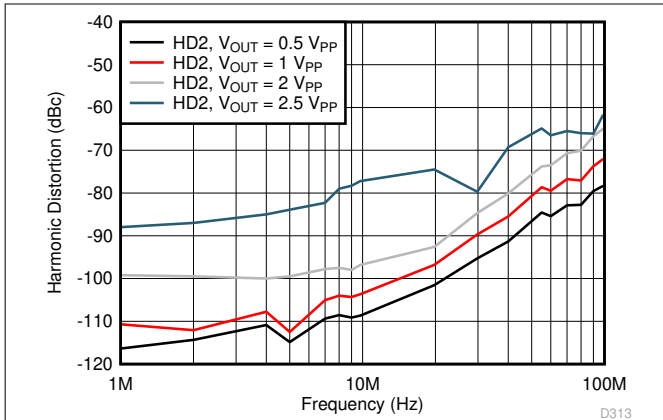

图 6-15. Harmonic Distortion (HD2) vs Output Load

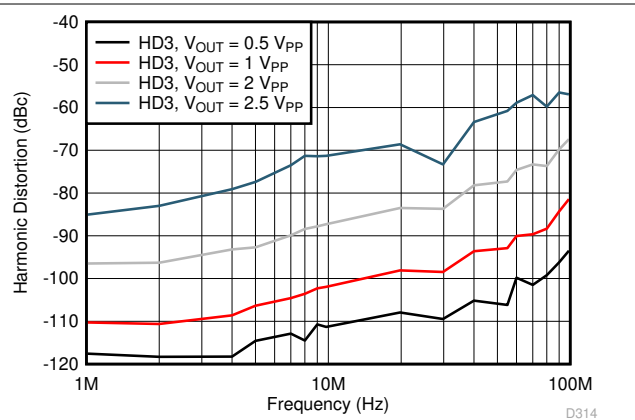

图 6-16. Harmonic Distortion (HD3) vs Output Load

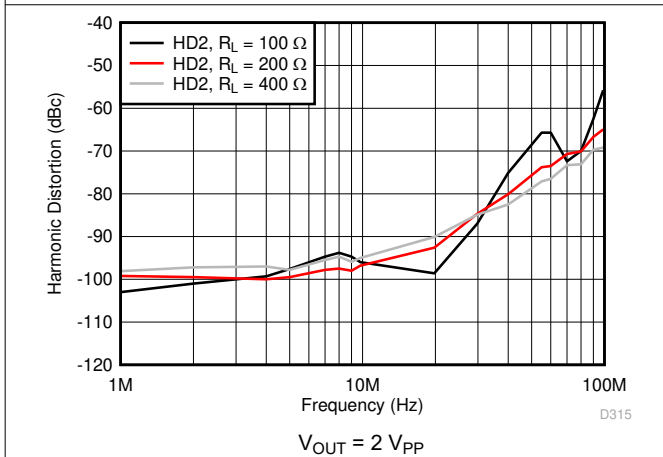

图 6-17. Harmonic Distortion (HD2) vs Gain

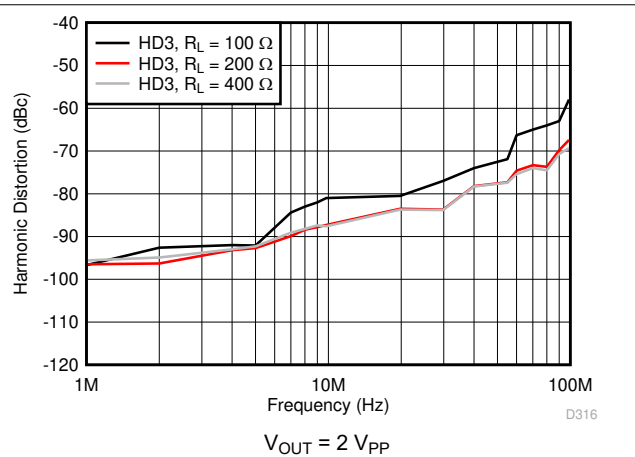

图 6-18. Harmonic Distortion (HD3) vs Gain

6.6 Typical Characteristics (continued)

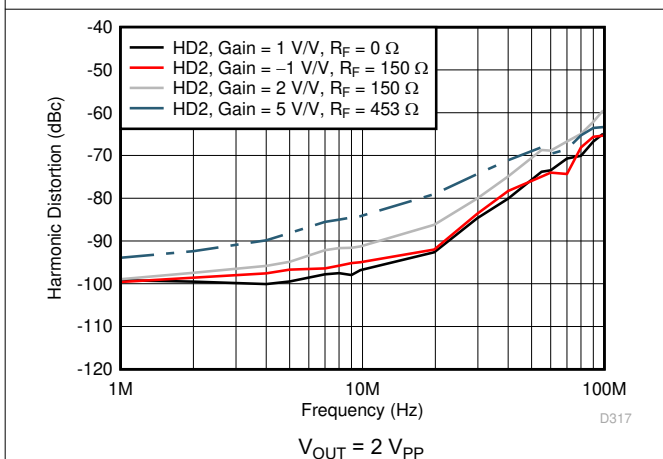
at $T_A = 25^\circ\text{C}$, $V_{S+} = 2.5\text{ V}$, $V_{S-} = -2.5\text{ V}$, $V_{IN+} = 0\text{ V}$, Gain = 1 V/V, $R_F = 0\ \Omega$, $R_L = 200\ \Omega$, and output load referenced to midsupply (unless otherwise noted)

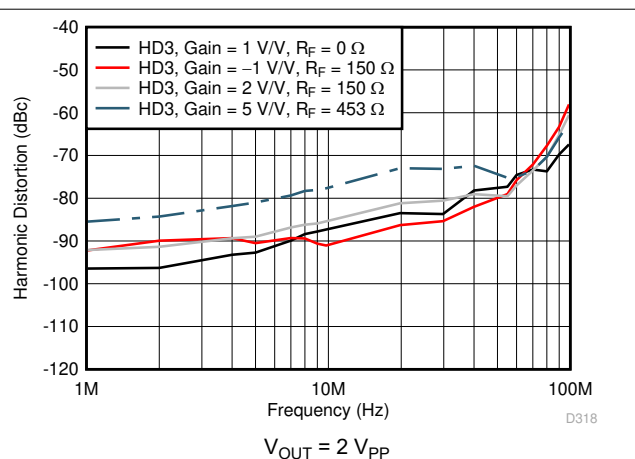
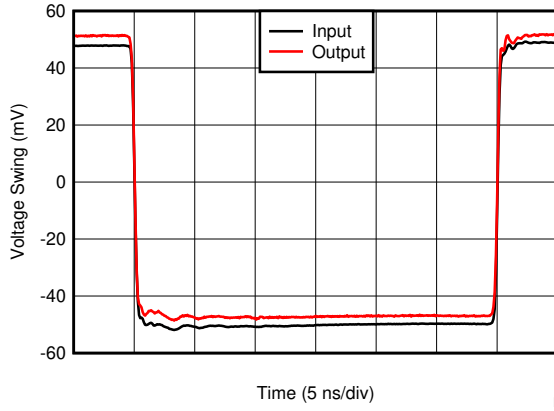

Average Rise and Fall Time (10% - 90%) = 450 ps

图 6-19. Small-Signal Transient Response

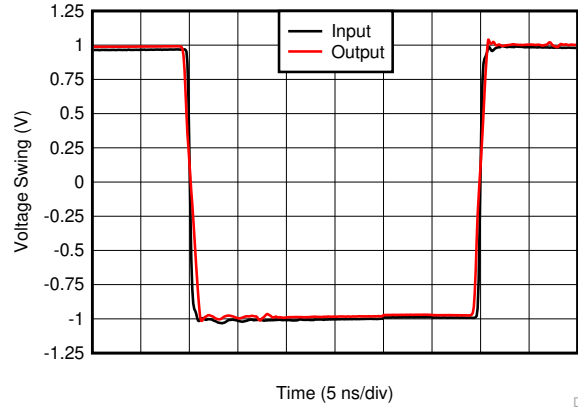

Slew Rate: Falling = 1160 V/ μs , Rising = 1400 V/ μs

图 6-20. Large-Signal Transient Response

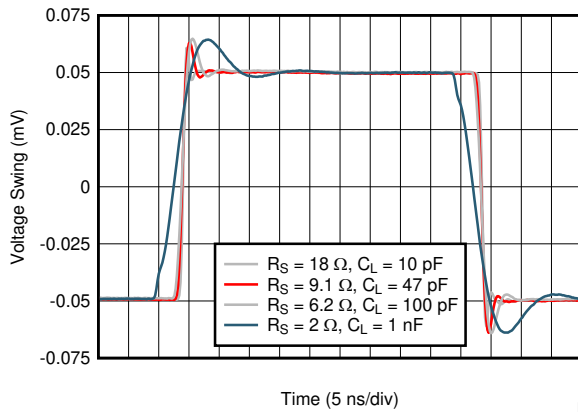

See 图 7-4 for circuit configuration

图 6-21. Small-Signal Transient Response vs Capacitive Load

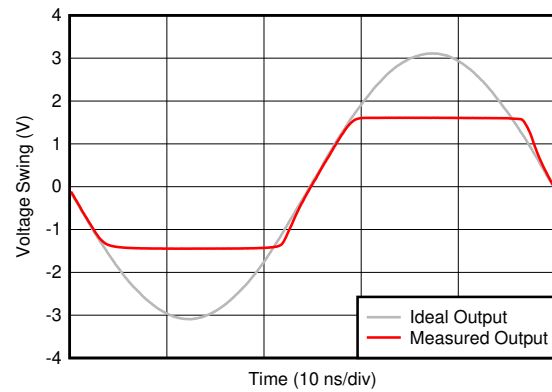

Gain = 5 V/V, $R_F = 453\ \Omega$, 2x Output Overdrive

图 6-22. Output Overload Response



图 6-23. Turnon Transient Response



图 6-24. Turnoff Transient Response

6.6 Typical Characteristics (continued)

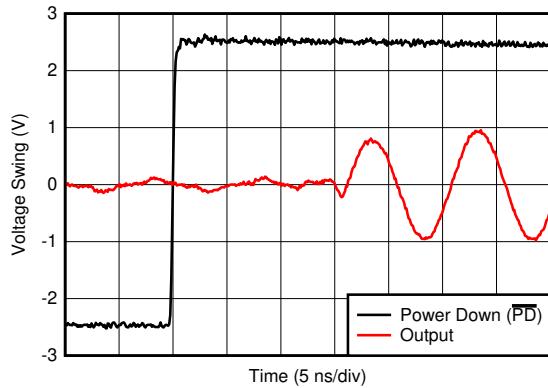
at $T_A = 25^\circ\text{C}$, $V_{S+} = 2.5\text{ V}$, $V_{S-} = -2.5\text{ V}$, $V_{IN+} = 0\text{ V}$, Gain = 1 V/V, $R_F = 0\ \Omega$, $R_L = 200\ \Omega$, and output load referenced to midsupply (unless otherwise noted)

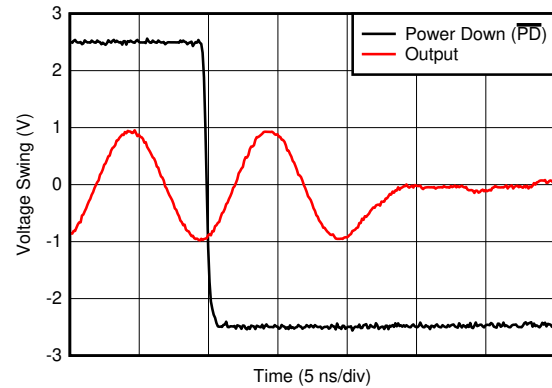

图 6-25. Common-Mode Rejection Ratio vs Frequency



图 6-26. Power Supply Rejection Ratio vs Frequency

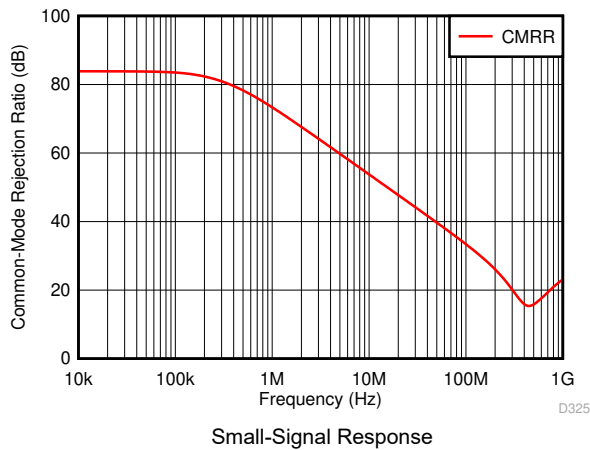

图 6-27. Quiescent Current vs Supply Voltage

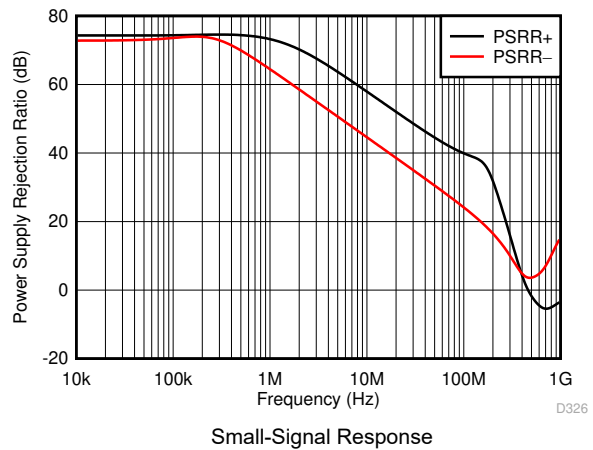

图 6-28. Quiescent Current vs Ambient Temperature

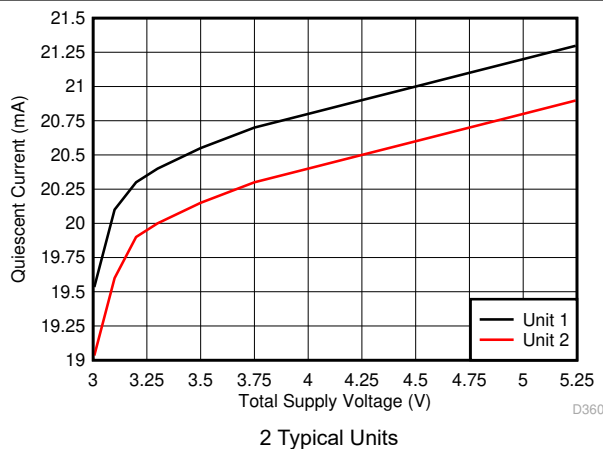

图 6-29. Quiescent Current (Amplifier Disabled) vs Ambient Temperature

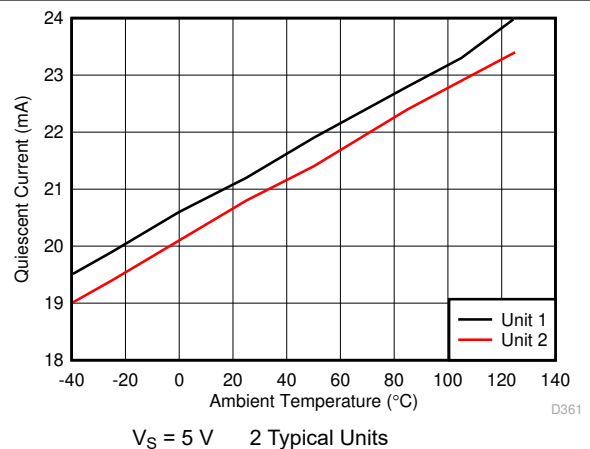

图 6-30. Offset Voltage vs Supply Voltage

6.6 Typical Characteristics (continued)

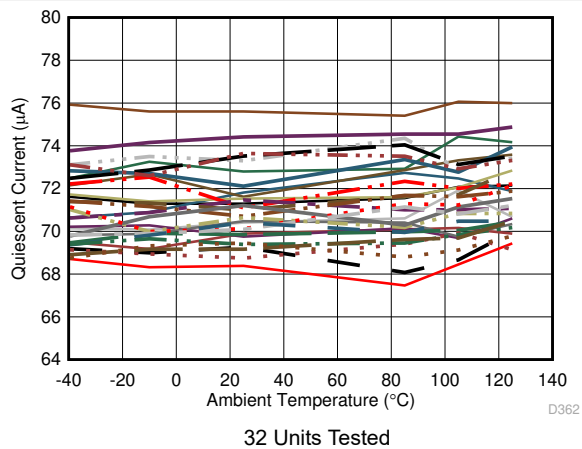
at $T_A = 25^\circ\text{C}$, $V_{S+} = 2.5\text{ V}$, $V_{S-} = -2.5\text{ V}$, $V_{IN+} = 0\text{ V}$, Gain = 1 V/V, $R_F = 0\ \Omega$, $R_L = 200\ \Omega$, and output load referenced to midsupply (unless otherwise noted)

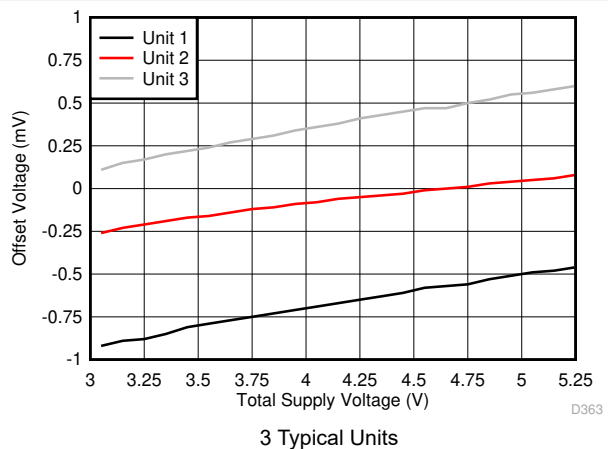

图 6-31. Offset Voltage vs Ambient Temperature



图 6-32. Offset Voltage vs Input Common-Mode Voltage

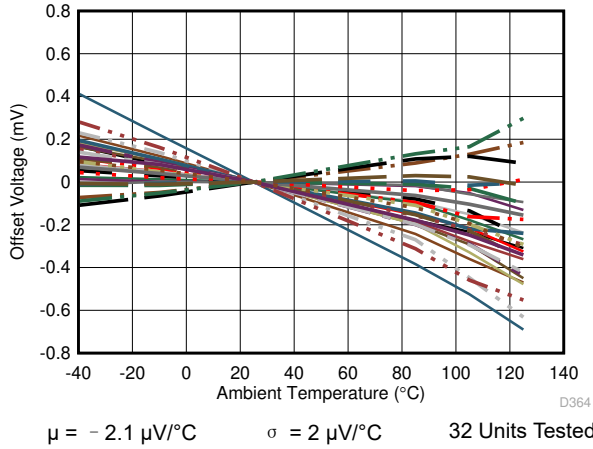

图 6-33. Offset Voltage vs Input Common-Mode Voltage vs Ambient Temperature

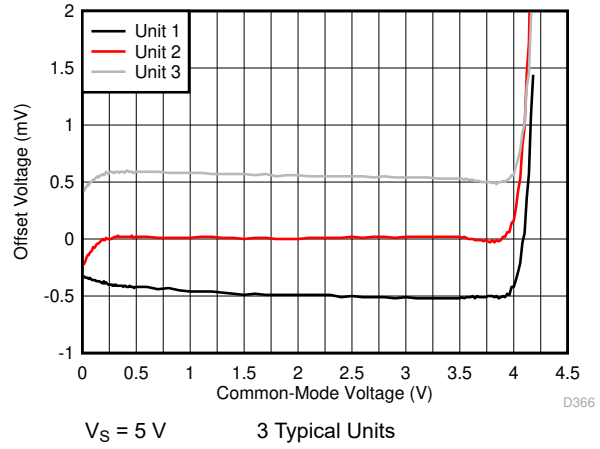

图 6-34. Offset Voltage vs Output Swing

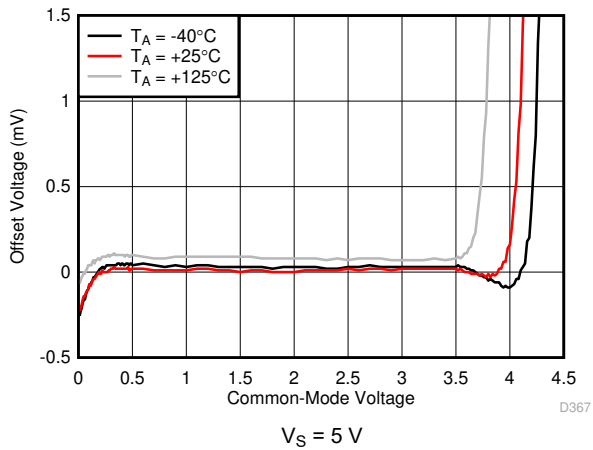

图 6-35. Offset Voltage vs Output Swing vs Ambient Temperature

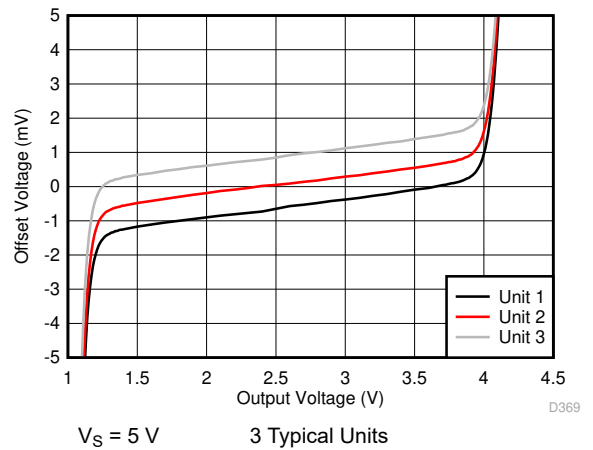

图 6-36. Input Bias Current vs Ambient Temperature

6.6 Typical Characteristics (continued)

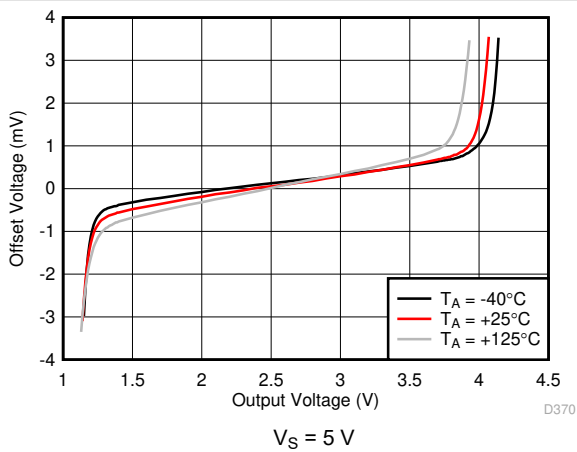
at $T_A = 25^\circ\text{C}$, $V_{S+} = 2.5\text{ V}$, $V_{S-} = -2.5\text{ V}$, $V_{IN+} = 0\text{ V}$, Gain = 1 V/V, $R_F = 0\ \Omega$, $R_L = 200\ \Omega$, and output load referenced to midsupply (unless otherwise noted)

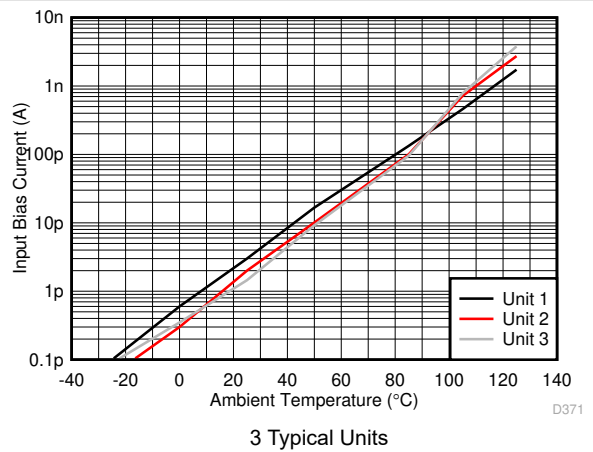

图 6-37. Input Bias Current vs Input Common-Mode Voltage



图 6-38. Output Swing vs Sinking Current

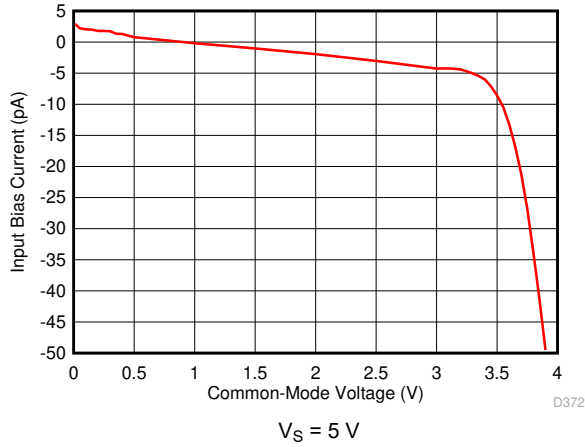

图 6-39. Output Swing vs Sourcing Current

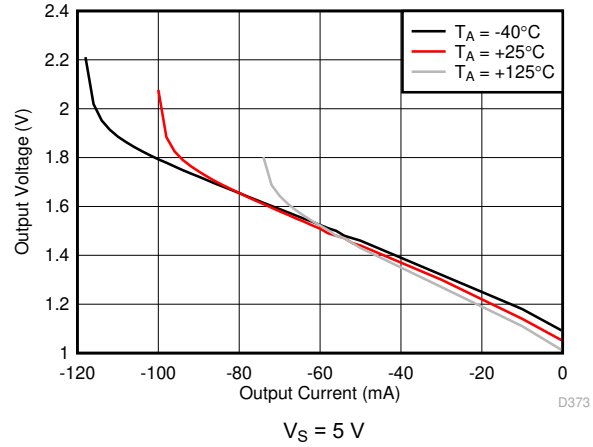

图 6-40. Quiescent Current Distribution

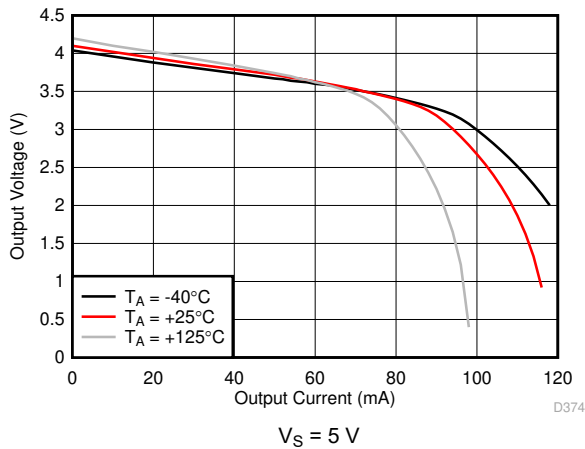

图 6-41. Offset Voltage Distribution

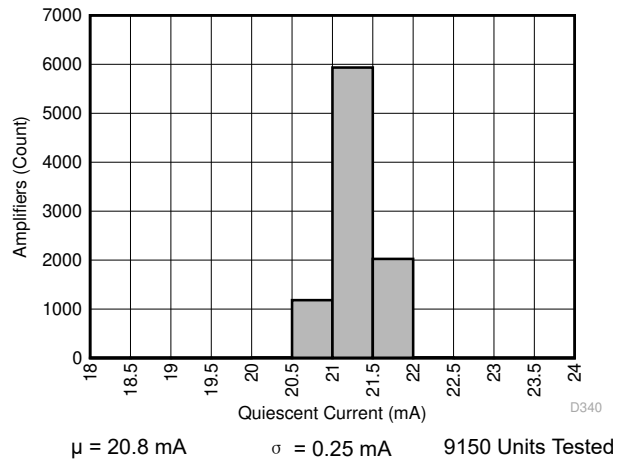

图 6-42. Input Bias Current Distribution

7 Parameter Measurement Information

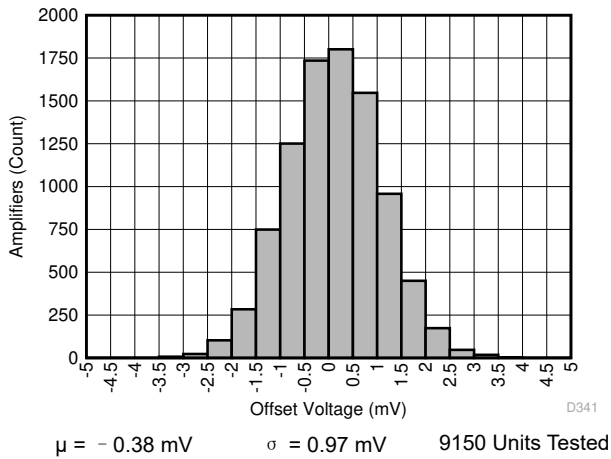
The various test setup configurations for the OPA859-Q1 are shown in the figures below. When configuring the OPA859-Q1 as a noninverting amplifier in gains less 3 V/V, set $R_F = 150 \Omega$. When configuring the OPA859-Q1 as a noninverting amplifier in gains of 4 V/V and greater, set $R_F = 453 \Omega$.

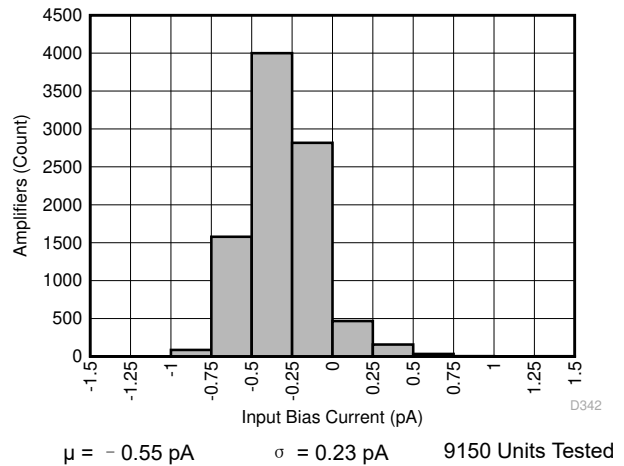

图 7-1. Unity-Gain Buffer Configuration



R_G values depend on gain configuration

图 7-2. Noninverting Configuration

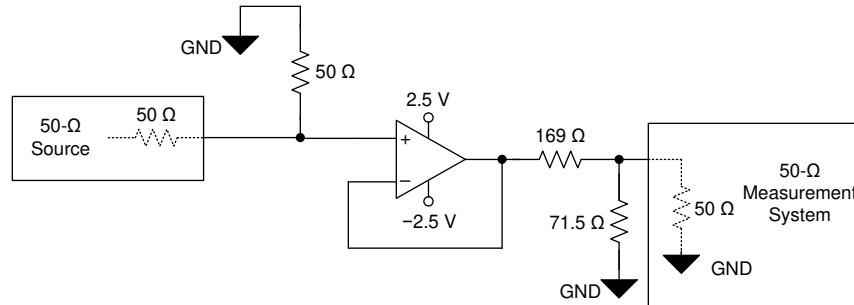
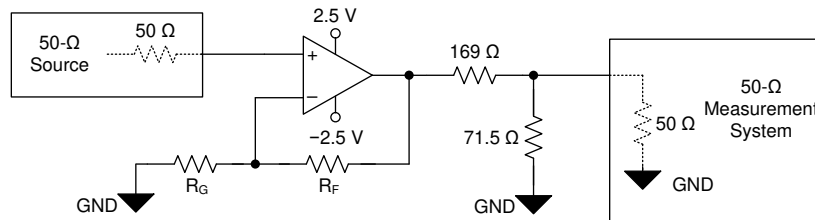

图 7-3. Inverting Configuration (Gain = -1 V/V)



图 7-4. Capacitive Load Driver Configuration

8 Detailed Description

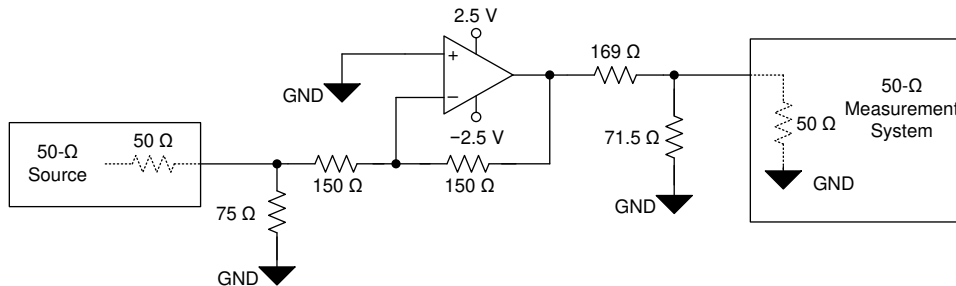
8.1 Overview

The ultra-wide, 900-MHz gain bandwidth product (GBWP) of the OPA859-Q1, combined with the broadband voltage noise of $3.3 \text{ nV}/\sqrt{\text{Hz}}$, produces a viable amplifier for wideband transimpedance applications, high-speed data acquisition systems, and applications with weak signal inputs that require low-noise and high-gain front ends. The OPA859-Q1 combines multiple features to optimize dynamic performance. In addition to the wide small-signal bandwidth, the OPA859-Q1 has 400 MHz of large-signal bandwidth ($V_{\text{OUT}} = 2 V_{\text{PP}}$), and a slew rate of $1150 \text{ V}/\mu\text{s}$.

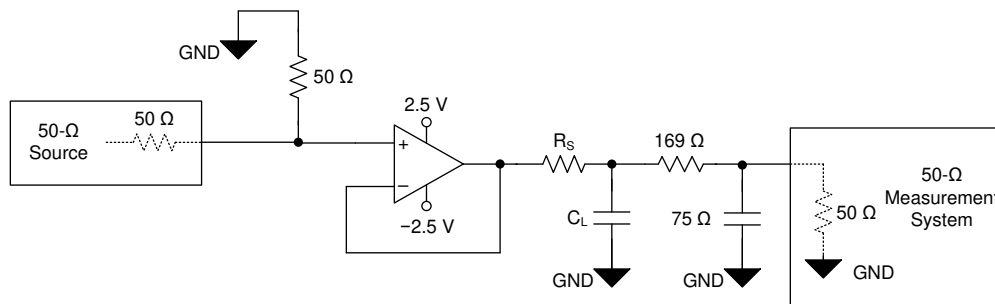
The OPA859-Q1 is offered in a 2-mm × 2-mm, 8-pin WSON package that features a feedback (FB) pin for a simple feedback network connection between the amplifiers output and inverting input. Excess capacitance on an amplifiers input pin can reduce phase margin causing instability. This problem is exacerbated in the case of very wideband amplifiers like the OPA859-Q1. To reduce the effects of stray capacitance on the input node, the OPA859-Q1 pinout features an isolation pin (NC) between the feedback and inverting input pins that increases the physical spacing between them thereby reducing parasitic coupling at high frequencies. The OPA859-Q1 also features a very low capacitance input stage with only 0.8-pF of total input capacitance.

8.2 Functional Block Diagram

The OPA859-Q1 is a classic voltage feedback operational amplifier (op amp) with two high-impedance inputs and a low-impedance output. Standard application circuits are supported, like the two basic options shown in [Figure 8-1](#) and [Figure 8-2](#). The DC operating point for each configuration is level-shifted by the reference voltage (V_{REF}), which is typically set to midsupply in single-supply operation. V_{REF} is typically connected to ground in split-supply applications.



图 8-1. Noninverting Amplifier



图 8-2. Inverting Amplifier

8.3 Feature Description

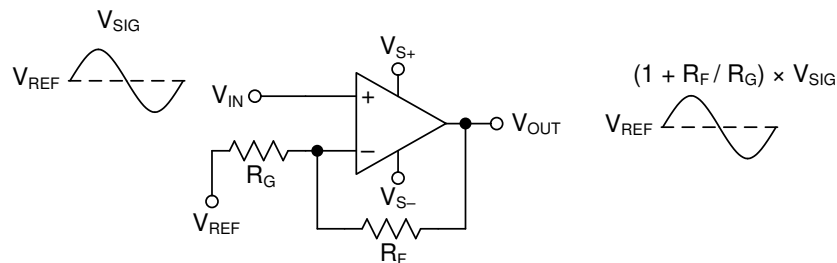
8.3.1 Input and ESD Protection

The OPA859-Q1 is fabricated on a low-voltage, high-speed, BiCMOS process. The internal, junction breakdown voltages are low for these small geometry devices, and as a result, all device pins are protected with internal ESD protection diodes to the power supplies as [图 8-3](#) shows. There are two antiparallel diodes between the inputs of the amplifier that clamp the inputs during an overrange or fault condition.

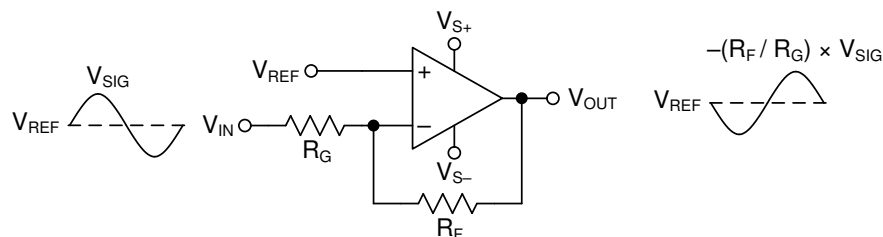

图 8-3. Internal ESD Structure

8.3.2 Feedback Pin

The OPA859-Q1 pin layout is optimized to minimize parasitic inductance and capacitance, which is a critical care about in high-speed analog design. The FB pin (pin 1) is internally connected to the output of the amplifier. The FB pin is separated from the inverting input of the amplifier (pin 3) by a no connect (NC) pin (pin 2). The NC pin must be left floating. There are two advantages to this pin layout:

1. A feedback resistor (R_F) can connect between the FB and IN - pin on the same side of the package (see [图 8-4](#)) rather than going around the package.
2. The isolation created by the NC pin minimizes the capacitive coupling between the FB and IN - pins by increasing the physical separation between the pins.

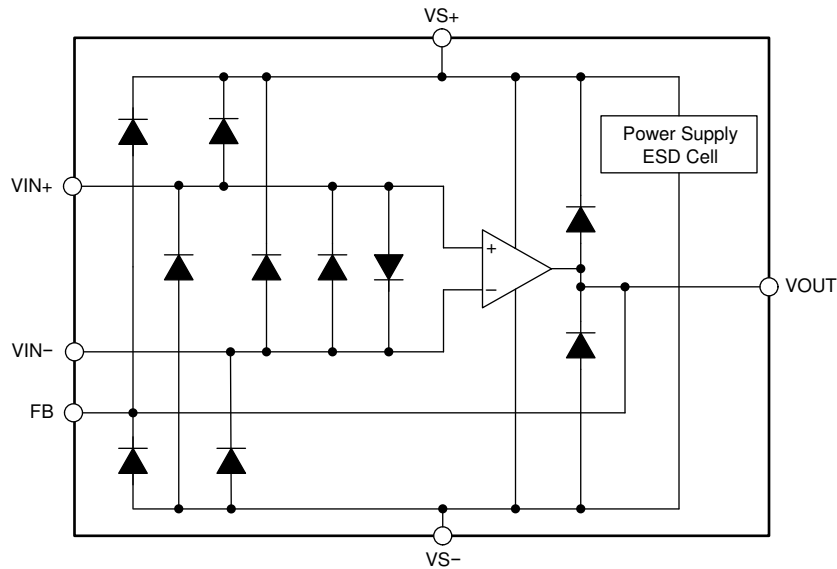

图 8-4. R_F Connection Between FB and IN - Pins

8.3.3 Wide Gain-Bandwidth Product

图 6-10 shows the open-loop magnitude and phase response of the OPA859-Q1. Calculate the gain bandwidth product of any op amp by determining the frequency at which the A_{OL} is 40 dB and multiplying that frequency by a factor of 100. The open-loop response shows the OPA859-Q1 to have approximately 63° of phase-margin when configured as a unity-gain buffer.

图 8-5 shows the open-loop magnitude (A_{OL}) of the OPA859-Q1 as a function of temperature. The results show approximately 5° of phase-margin variation over the entire temperature range. Semiconductor process variation is the naturally occurring variation in the attributes of a transistor (Early-voltage, β , channel-length, and width) and other passive elements (resistors and capacitors) when fabricated into an integrated circuit. The process variation can occur across devices on a single wafer or across devices over multiple wafer lots over time. Typically the variation across a single wafer is tightly controlled. 图 8-6 shows the A_{OL} magnitude of the OPA859-Q1 as a function of process variation over time. The results show the A_{OL} curve for the nominal process corner and the variation one standard deviation from the nominal. The simulated results show less than 2° of phase-margin difference within a standard deviation of process variation when the amplifier is configured as a unity-gain buffer.

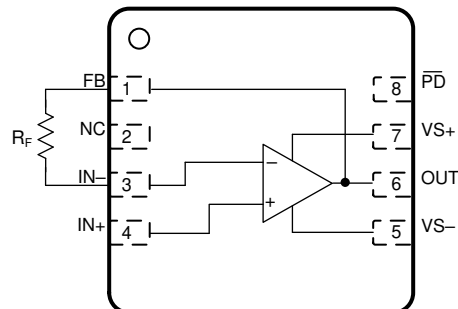
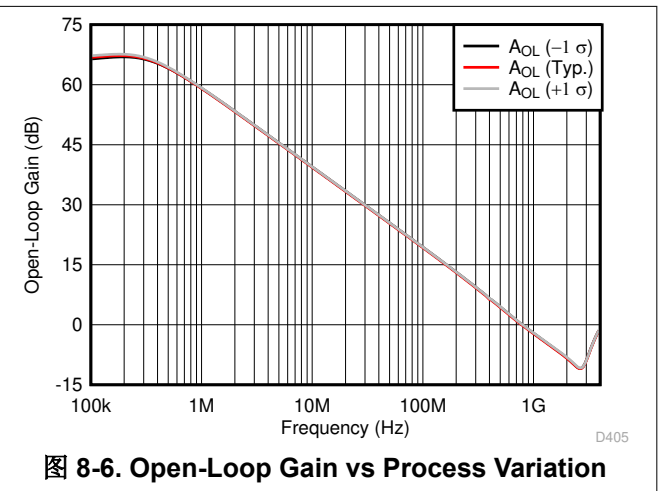
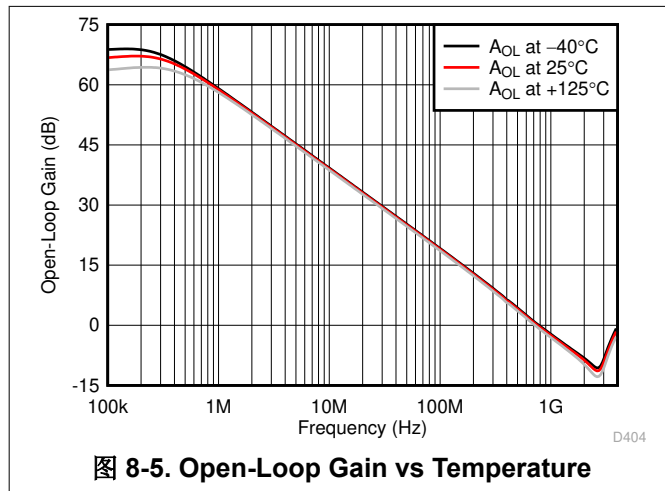

8.3.4 Slew Rate and Output Stage

In addition to wide bandwidth, the OPA859-Q1 features a high slew rate of 2750 V/ μ s. The slew rate is a critical parameter in high-speed pulse applications with narrow sub-10-ns pulses, such as optical time-domain reflectometry (OTDR) and LIDAR. The high slew rate of the OPA859-Q1 implies that the device accurately reproduces a 2-V, sub-ns pulse edge, as seen in 图 6-20. The wide bandwidth and slew rate of the OPA859-Q1 make it an excellent amplifier for high-speed signal-chain front ends.

图 8-7 shows the open-loop output impedance of the OPA859-Q1 as a function of frequency. To achieve high slew rates and low output impedance across frequency, the output swing of the OPA859-Q1 is limited to approximately 3 V. The OPA859-Q1 is typically used in conjunction with high-speed pipeline ADCs and flash ADCs that have limited input ranges. Therefore, the OPA859-Q1 output swing range coupled with the class-leading voltage noise specification for a CMOS amplifier maximizes the overall dynamic range of the signal chain.



图 8-7. Open-Loop Output Impedance (Z_{OL}) vs Frequency

8.3.5 Current Noise

The input impedance of CMOS and JFET input amplifiers at low frequencies exceed several $G\Omega$ s. However, at higher frequencies, the transistors parasitic capacitance to the drain, source, and substrate reduces the impedance. The high impedance at low frequencies eliminates any bias current and the associated shot noise. At higher frequencies, the input current noise increases (see 图 8-8) as a result of capacitive coupling between the CMOS gate oxide and the underlying transistor channel. This phenomenon is a natural artifact of the construction of the transistor and is unavoidable.

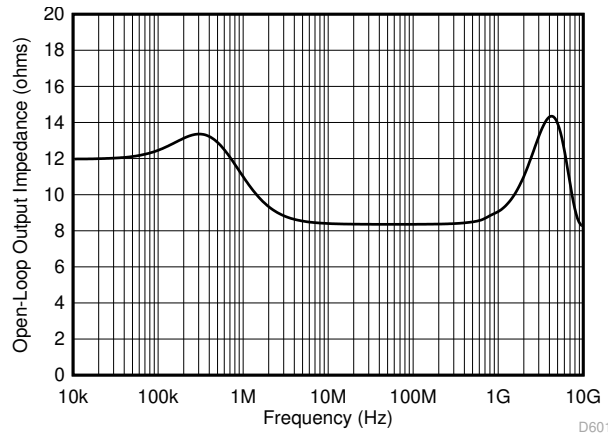

图 8-8. Input Current Noise (I_{BN} and I_{BI}) vs Frequency

8.4 Device Functional Modes

8.4.1 Split-Supply and Single-Supply Operation

The OPA859-Q1 can be configured with single-sided supplies or split-supplies as shown in [图 10-1](#). Split-supply operation using balanced supplies with the input common-mode set to ground eases lab testing because most signal generators, network analyzers, spectrum analyzers, and other lab equipment typically reference inputs and outputs to ground. In split-supply operation, the thermal pad must be connected to the negative supply.

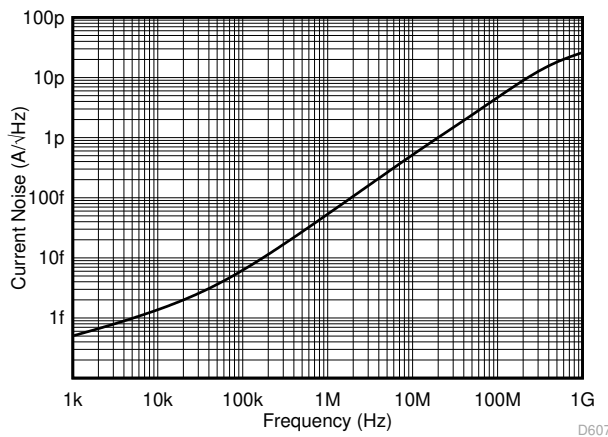
Newer systems use a single power supply to improve efficiency and reduce the cost of the extra power supply. The OPA859-Q1 can be used with a single positive supply (negative supply at ground) with no change in performance if the input common-mode and output swing are biased within the linear operation of the device. In single-supply operation, level shift the DC input and output reference voltages by half the difference between the power supply rails. This configuration maintains the input common-mode and output load reference at midsupply. To eliminate gain errors, the source driving the reference input common-mode voltage must have low output impedance across the frequency range of interest. In this case, the thermal pad must be connected to ground.

8.4.2 Power-Down Mode

The OPA859-Q1 features a power-down mode to reduce the quiescent current to conserve power. [图 6-23](#) and [图 6-24](#) show the transient response of the OPA859-Q1 as the $\overline{\text{PD}}$ pin toggles between the disabled and enabled states.

The $\overline{\text{PD}}$ disable and enable threshold voltages are with reference to the negative supply. If the amplifier is configured with the positive supply at 3.3 V and the negative supply at ground, then the disable and enable threshold voltages are 0.65 V and 1.8 V, respectively. If the amplifier is configured with ± 1.65 V supplies, then the threshold voltages are at -1 V and 0.15 V. If the amplifier is configured with ± 2.5 V supplies, then the threshold voltages are at -1.85 V and -0.7 V.

[图 8-9](#) shows the switching behavior of a typical amplifier as the $\overline{\text{PD}}$ pin is swept down from the enabled state to the disabled state. Similarly, [图 8-10](#) shows the switching behavior of a typical amplifier as the $\overline{\text{PD}}$ pin is swept up from the disabled state to the enabled state. The small difference in the switching thresholds between the down sweep and the up sweep is caused by the hysteresis designed into the amplifier to increase immunity to noise on the $\overline{\text{PD}}$ pin.



图 8-9. Switching Threshold ($\overline{\text{PD}}$ Pin Swept from High to Low)



图 8-10. Switching Threshold ($\overline{\text{PD}}$ Pin Swept from Low to High)

Connecting the $\overline{\text{PD}}$ pin low disables the amplifier and places the output in a high-impedance state. When the amplifier is configured as a noninverting amplifier, the feedback (R_F) and gain (R_G) resistor network form a parallel load to the output of the amplifier. To protect the input stage of the amplifier, the OPA859-Q1 uses internal, back-to-back protection diodes between the inverting and noninverting input pins as [图 8-3](#) shows. In the power-down state, if the differential voltage between the input pins of the amplifier exceeds a diode voltage drop, an additional low-impedance path is created between the noninverting input pin and the output pin.

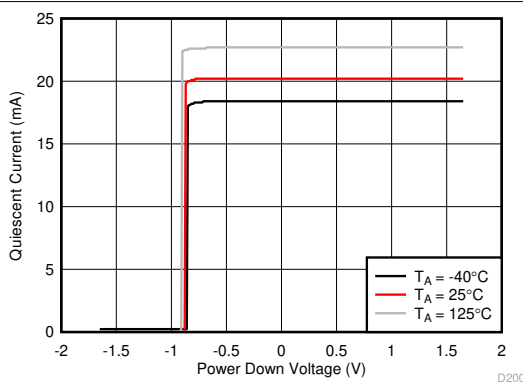
9 Application and Implementation

Note

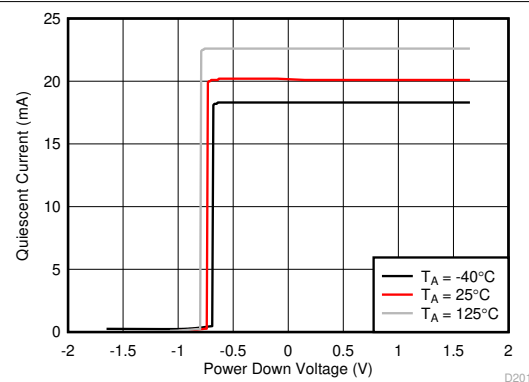
以下应用部分中的信息不属于 TI 器件规格的范围，TI 不担保其准确性和完整性。TI 的客户应负责确定器件是否适用于其应用。客户应验证并测试其设计，以确保系统功能。

9.1 Application Information

The OPA859-Q1 offers high input impedance, very high-bandwidth, high slew-rate, low noise, and better than -60 dBc of distortion performance at frequencies up to 100 MHz. These features make this device an excellent front-end buffer in high-speed data acquisition systems. The wide bandwidth also makes this amplifier an excellent choice for high-gain active filter systems.

9.2 Typical Application

图 9-1 shows the OPA859-Q1 configured as a transimpedance amplifier (U1) in a wide-bandwidth, optical front-end system. A second OPA859-Q1 configured as a unity-gain buffer (U2) sets a dc offset voltage to the THS4520. The THS4520 is used to convert the single-ended transimpedance output of the OPA859-Q1 into a differential output signal. The THS4520 drives the input of the ADS54J64, 14-bit, 1-GSPS analog-to-digital converter (ADC) that digitizes the analog signal.



图 9-1. OPA859-Q1 as Both a TIA and a Buffer in an Optical Front-End System

9.2.1 Design Requirements

The objective is to design a low noise, wideband optical front-end system using the OPA859-Q1 as a transimpedance amplifier. The design requirements are:

- Amplifier supply voltage: 5 V
- TIA common-mode voltage: 3.5 V
- THS4520 gain: 1 V/V
- ADC input common-mode voltage: 1.3 V
- ADC analog differential input range: 1.1 V_{PP}

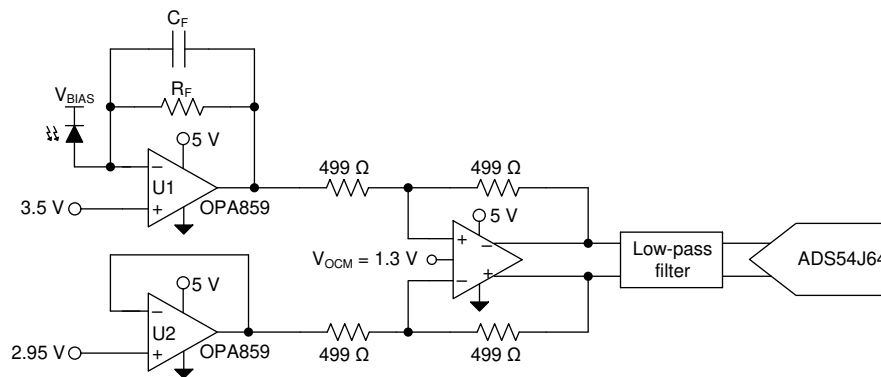
9.2.2 Detailed Design Procedure

The OPA859-Q1 meets the growing demand for wideband, low-noise photodiode amplifiers. The closed-loop bandwidth of a transimpedance amplifier is a function of the following:

1. The total input capacitance (C_{IN}). This total includes the photodiode capacitance, the input capacitance of the amplifier (common-mode and differential capacitance) and any stray capacitance from the PCB.
2. The op amp gain bandwidth product (GBWP).
3. The transimpedance gain (R_F).

图 9-1 shows the OPA859-Q1 configured as a TIA, with the avalanche photodiode (APD) reverse biased so that the APD cathode is tied to a large positive bias voltage. In this configuration, the APD sources current into the op amp feedback loop so that the output swings in a negative direction relative to the input common-mode voltage. To maximize the output swing in the negative direction, the OPA859-Q1 common-mode voltage is set close to the positive limit; only 1.5 V from the positive supply rail. The feedback resistance (R_F) and the input capacitance (C_{IN}) form a zero in the noise gain that results in instability if left unchecked. To counteract the effect of the zero, a pole is inserted into the noise gain transfer function by adding the feedback capacitor (C_F).

The [Transimpedance Considerations for High-Speed Amplifiers Application Report](#) discusses theories and equations that show how to compensate a transimpedance amplifier for a particular transimpedance gain and input capacitance. The bandwidth and compensation equations from the application report are available in an Excel® calculator. [What You Need To Know About Transimpedance Amplifiers – Part 1](#) provides a link to the calculator.

The equations and calculators in the referenced application report and blog posts are used to model the bandwidth (f_{-3dB}) and noise (I_{RN}) performance of the OPA859-Q1 configured as a TIA. The resultant performance is shown in 图 9-2 and 图 9-3. The left-side Y-axis shows the closed-loop bandwidth performance, whereas the right side of the graph shows the integrated input-referred noise. The noise bandwidth to calculate I_{RN} for a fixed R_F and C_{PD} is set equal to the f_{-3dB} frequency. 图 9-2 shows the amplifier performance as a function of photodiode capacitance (C_{PD}) for $R_F = 10\text{ k}\Omega$ and $20\text{ k}\Omega$. Increasing C_{PD} decreases the closed-loop bandwidth. To maximize bandwidth, make sure to reduce any stray parasitic capacitance from the PCB. The OPA859-Q1 is designed with 0.8 pF of total input capacitance to minimize the effect of stray capacitance on system performance. 图 9-3 shows the amplifier performance as a function of R_F for $C_{PD} = 1\text{ pF}$ and 2 pF . Increasing R_F results in lower bandwidth. To maximize the signal-to-noise ratio (SNR) in an optical front-end system, maximize the gain in the TIA stage. Increasing R_F by a factor of X increases the signal level by X, but only increases the resistor noise contribution by \sqrt{X} , thereby improving SNR.

The OPA859-Q1 configured as a unity-gain buffer drives a dc offset voltage of 2.95 V into the lower half of the THS4520. To maximize the dynamic range of the ADC, the two OPA859 amplifiers drive a differential common-mode of 3.5 V and 2.95 V into the THS4520. The dc offset voltage of the buffer amplifier can be derived using 方程式 1.

$$V_{BUF_DC} = V_{TIA_CM} - \left(\frac{1}{2} \times \frac{V_{ADC_DIFF_IN}}{\left(\frac{R_F}{R_G} \right)} \right) \quad (1)$$

where

- V_{TIA_CM} is the common-mode voltage of the TIA (3.5 V)
- $V_{ADC_DIFF_IN}$ is the differential input voltage range of the ADC (1.1 V_{PP})
- R_F and R_G are the feedback resistance ($499\ \Omega$) and gain resistance ($499\ \Omega$) of the THS4520 differential amplifier

The low-pass filter between the THS4520 and the ADC54J64 minimizes high-frequency noise and maximizes SNR. The ADC54J64 has an internal buffer that isolates the output of the THS4520 from the ADC sampling-capacitor input, so a traditional charge bucket filter is not required.

9.2.3 Application Curves

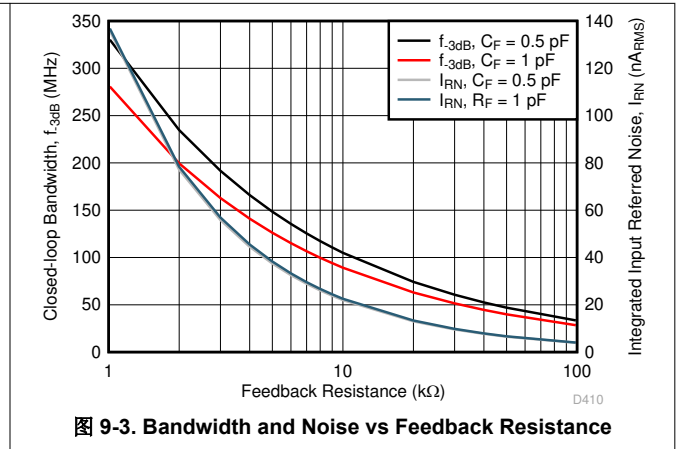
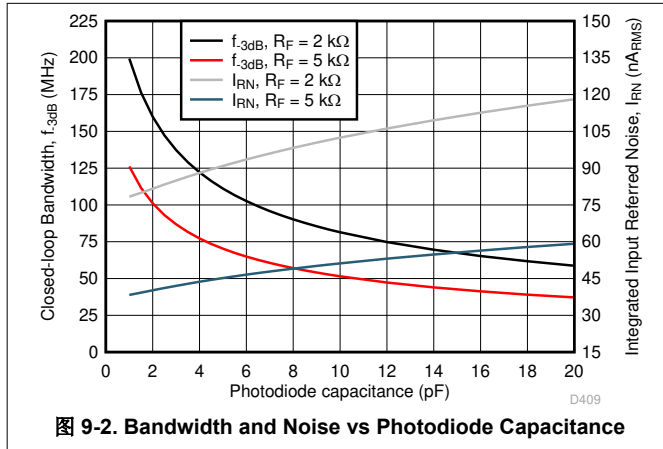

10 Power Supply Recommendations

The OPA859-Q1 operates on supplies from 3.3 V to 5.25 V. The OPA859-Q1 operates on single-sided supplies, split and balanced bipolar supplies, and unbalanced bipolar supplies. Because the OPA859-Q1 does not feature rail-to-rail inputs or outputs, the input common-mode and output swing ranges are limited at 3.3-V supplies.

a) Single supply configuration

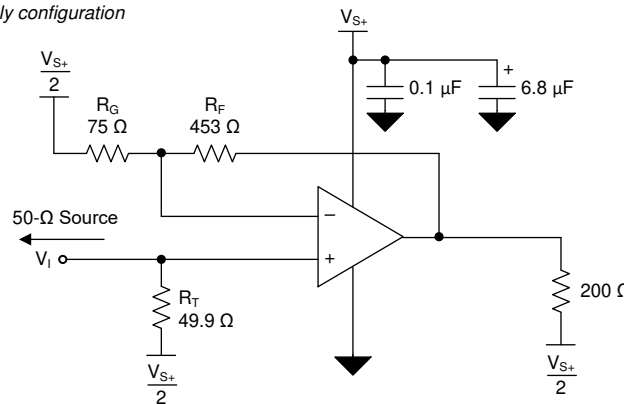

b) Split supply configuration



图 10-1. Split and Single Supply Circuit Configuration , Gain = 7 V/V

11 Layout

11.1 Layout Guidelines

Achieving optimum performance with a high-frequency amplifier like the OPA859-Q1 requires careful attention to board layout parasitics and external component types. Recommendations that optimize performance include:

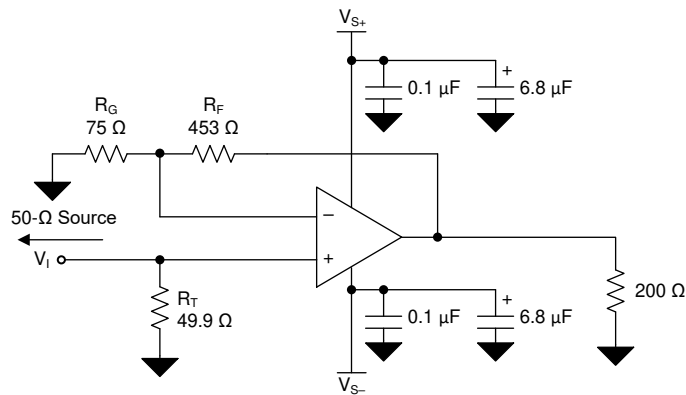
- **Minimize parasitic capacitance from the signal I/O pins to ac ground.** Parasitic capacitance on the output and inverting input pins can cause instability. To reduce unwanted capacitance, cut out the power and ground traces under the signal input and output pins. Otherwise, ground and power planes must be unbroken elsewhere on the board. When configuring the amplifier as a TIA, if the required feedback capacitor is less than 0.15 pF, consider using two series resistors, each of half the value of a single resistor in the feedback loop to minimize the parasitic capacitance from the resistor.
- **Minimize the distance (less than 0.25-in) from the power-supply pins to high-frequency bypass capacitors.** Use high-quality, 100-pF to 0.1- μ F, C0G and NPO-type decoupling capacitors with voltage ratings at least three times greater than the amplifiers maximum power supplies. This configuration makes sure that there is a low-impedance path to the amplifiers power-supply pins across the amplifiers gain bandwidth specification. At the device pins, do not allow the ground and power plane layout to be in close proximity to the signal I/O pins. Avoid narrow power and ground traces to minimize inductance between the pins and the decoupling capacitors. The power-supply connections must always be decoupled with these capacitors. Larger (2.2- μ F to 6.8- μ F) decoupling capacitors that are effective at lower frequency must be used on the supply pins. Place these decoupling capacitors further from the device. Share the decoupling capacitors among several devices in the same area of the printed circuit board (PCB).
- **Careful selection and placement of external components preserves the high-frequency performance of the OPA859-Q1.** Use low-reactance resistors. Surface-mount resistors work best and allow a tighter overall layout. Never use wirewound resistors in a high-frequency application. Because the output pin and inverting input pin are the most sensitive to parasitic capacitance, always position the feedback and series output resistor, if any, as close to the output pin as possible. Place other network components (such as noninverting input termination resistors) close to the package. Even with a low parasitic capacitance shunting the external resistors, high resistor values create significant time constants that can degrade performance. When configuring the OPA859-Q1 as a voltage amplifier, keep resistor values as low as possible and consistent with load driving considerations. Decreasing the resistor values keeps the resistor noise terms low and minimizes the effect of the parasitic capacitance. However, lower resistor values increase the dynamic power consumption because R_F and R_G become part of the output load network of the amplifier.

11.2 Layout Example



图 11-1. Layout Recommendation

12 Device and Documentation Support

12.1 Device Support

12.1.1 Development Support

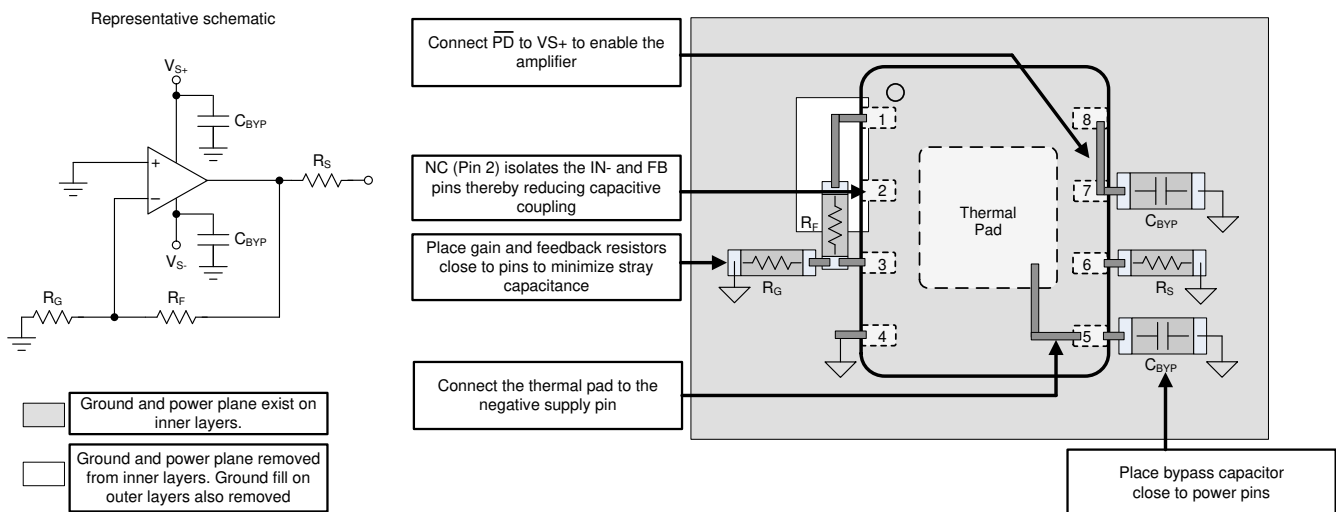
- [LIDAR Pulsed Time of Flight Reference Design](#)
- [LIDAR-Pulsed Time-of-Flight Reference Design Using High-Speed Data Converters](#)
- [Wide Bandwidth Optical Front-end Reference Design](#)

12.2 Documentation Support

12.2.1 Related Documentation

For related documentation see the following:

- Texas Instruments, [OPA858EVM user's guide](#)
- Texas Instruments, [Training Video: High-Speed Transimpedance Amplifier Design Flow](#)
- Texas Instruments, [Training Video: How to Design Transimpedance Amplifier Circuits](#)
- Texas Instruments, [Training Video: How to Convert a TINA-TI Model into a Generic SPICE Model](#)
- Texas Instruments, [Transimpedance Considerations for High-Speed Amplifiers application report](#)
- Texas Instruments, [What You Need To Know About Transimpedance Amplifiers - Part 1](#)
- Texas Instruments [What You Need To Know About Transimpedance Amplifiers - Part 2](#)

12.3 Receiving Notification of Documentation Updates

To receive notification of documentation updates, navigate to the device product folder on ti.com. In the upper right corner, click on *Alert me* to register and receive a weekly digest of any product information that has changed. For change details, review the revision history included in any revised document.

12.4 支持资源

TI E2E™ 支持论坛是工程师的重要参考资料，可直接从专家获得快速、经过验证的解答和设计帮助。搜索现有解答或提出自己的问题可获得所需的快速设计帮助。

链接的内容由各个贡献者“按原样”提供。这些内容并不构成 TI 技术规范，并且不一定反映 TI 的观点；请参阅 TI 的《使用条款》。

12.5 Trademarks

TI E2E™ is a trademark of Texas Instruments.

Excel® is a registered trademark of Microsoft Corporation.

所有商标均为其各自所有者的财产。

12.6 静电放电警告



静电放电 (ESD) 会损坏这个集成电路。德州仪器 (TI) 建议通过适当的预防措施处理所有集成电路。如果不遵守正确的处理和安装程序，可能会损坏集成电路。

ESD 的损坏小至导致微小的性能降级，大至整个器件故障。精密的集成电路可能更容易受到损坏，这是因为非常细微的参数更改都可能会导致器件与其发布的规格不相符。

12.7 术语表

TI 术语表 本术语表列出并解释了术语、首字母缩略词和定义。

13 Mechanical, Packaging, and Orderable Information

The following pages include mechanical, packaging, and orderable information. This information is the most current data available for the designated devices. This data is subject to change without notice and revision of this document. For browser-based versions of this data sheet, refer to the left-hand navigation.

PACKAGING INFORMATION

Orderable Device	Status (1)	Package Type	Package Drawing	Pins	Package Qty	Eco Plan (2)	Lead finish/ Ball material (6)	MSL Peak Temp (3)	Op Temp (°C)	Device Marking (4/5)	Samples
OPA859QDSGRQ1	ACTIVE	WSON	DSG	8	3000	RoHS & Green	NIPDAU	Level-2-260C-1 YEAR	-40 to 125	859Q	Samples

(1) The marketing status values are defined as follows:

ACTIVE: Product device recommended for new designs.

LIFEBUY: TI has announced that the device will be discontinued, and a lifetime-buy period is in effect.

NRND: Not recommended for new designs. Device is in production to support existing customers, but TI does not recommend using this part in a new design.

PREVIEW: Device has been announced but is not in production. Samples may or may not be available.

OBSOLETE: TI has discontinued the production of the device.

(2) **RoHS:** TI defines "RoHS" to mean semiconductor products that are compliant with the current EU RoHS requirements for all 10 RoHS substances, including the requirement that RoHS substance do not exceed 0.1% by weight in homogeneous materials. Where designed to be soldered at high temperatures, "RoHS" products are suitable for use in specified lead-free processes. TI may reference these types of products as "Pb-Free".

RoHS Exempt: TI defines "RoHS Exempt" to mean products that contain lead but are compliant with EU RoHS pursuant to a specific EU RoHS exemption.

Green: TI defines "Green" to mean the content of Chlorine (Cl) and Bromine (Br) based flame retardants meet JS709B low halogen requirements of <=1000ppm threshold. Antimony trioxide based flame retardants must also meet the <=1000ppm threshold requirement.

(3) MSL, Peak Temp. - The Moisture Sensitivity Level rating according to the JEDEC industry standard classifications, and peak solder temperature.

(4) There may be additional marking, which relates to the logo, the lot trace code information, or the environmental category on the device.

(5) Multiple Device Markings will be inside parentheses. Only one Device Marking contained in parentheses and separated by a "-" will appear on a device. If a line is indented then it is a continuation of the previous line and the two combined represent the entire Device Marking for that device.

(6) Lead finish/Ball material - Orderable Devices may have multiple material finish options. Finish options are separated by a vertical ruled line. Lead finish/Ball material values may wrap to two lines if the finish value exceeds the maximum column width.

Important Information and Disclaimer:The information provided on this page represents TI's knowledge and belief as of the date that it is provided. TI bases its knowledge and belief on information provided by third parties, and makes no representation or warranty as to the accuracy of such information. Efforts are underway to better integrate information from third parties. TI has taken and continues to take reasonable steps to provide representative and accurate information but may not have conducted destructive testing or chemical analysis on incoming materials and chemicals. TI and TI suppliers consider certain information to be proprietary, and thus CAS numbers and other limited information may not be available for release.

In no event shall TI's liability arising out of such information exceed the total purchase price of the TI part(s) at issue in this document sold by TI to Customer on an annual basis.

OTHER QUALIFIED VERSIONS OF OPA859-Q1 :

- Catalog : [OPA859](#)

NOTE: Qualified Version Definitions:

- Catalog - TI's standard catalog product

GENERIC PACKAGE VIEW

DSG 8

WSON - 0.8 mm max height

2 x 2, 0.5 mm pitch

PLASTIC SMALL OUTLINE - NO LEAD

This image is a representation of the package family, actual package may vary.
Refer to the product data sheet for package details.

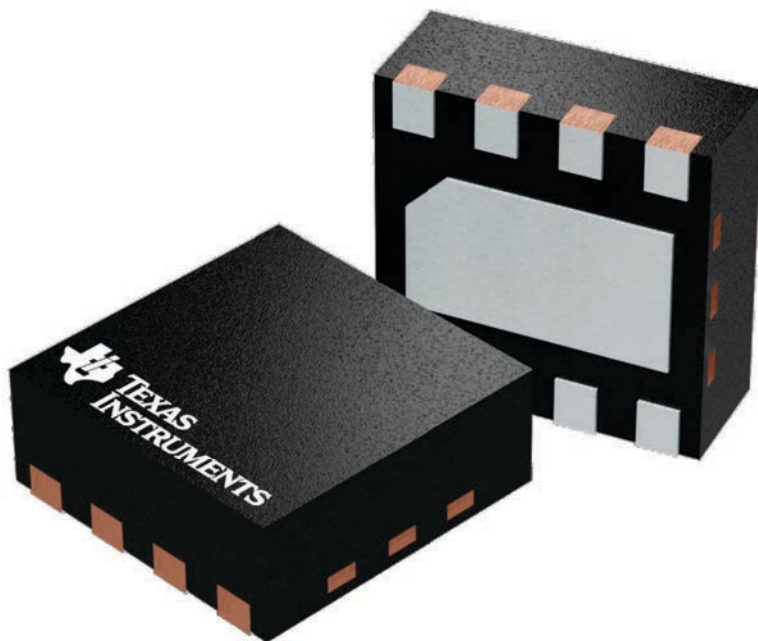

4224783/A

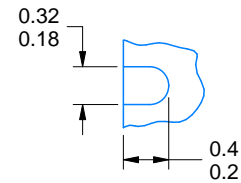
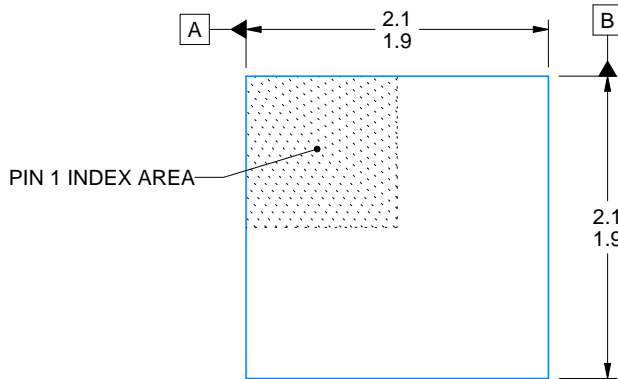
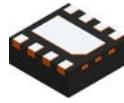

ALTERNATIVE TERMINAL SHAPE
TYPICAL

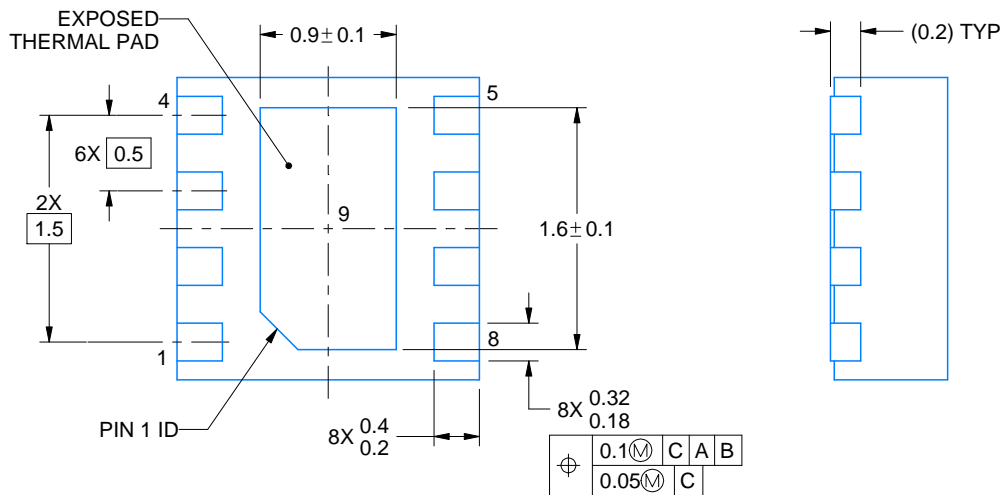
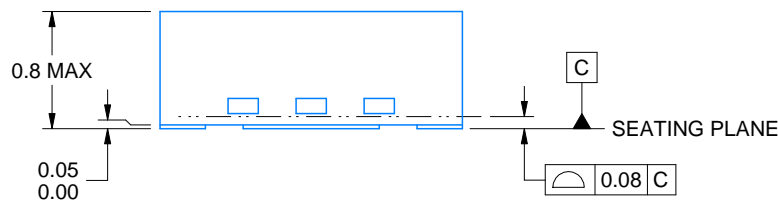

4218900/D 04/2020

NOTES:

1. All linear dimensions are in millimeters. Any dimensions in parenthesis are for reference only. Dimensioning and tolerancing per ASME Y14.5M.
2. This drawing is subject to change without notice.
3. The package thermal pad must be soldered to the printed circuit board for thermal and mechanical performance.

EXAMPLE STENCIL DESIGN

DSG0008A

WSON - 0.8 mm max height

PLASTIC SMALL OUTLINE - NO LEAD

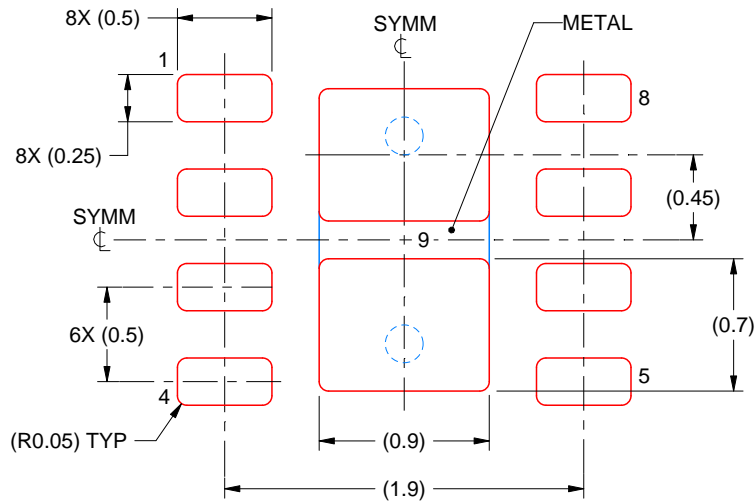

SOLDER PASTE EXAMPLE
BASED ON 0.125 mm THICK STENCIL

EXPOSED PAD 9:
87% PRINTED SOLDER COVERAGE BY AREA UNDER PACKAGE
SCALE:25X

4218900/D 04/2020

NOTES: (continued)

6. Laser cutting apertures with trapezoidal walls and rounded corners may offer better paste release. IPC-7525 may have alternate design recommendations.

重要声明和免责声明

TI 提供技术和可靠性数据（包括数据表）、设计资源（包括参考设计）、应用或其他设计建议、网络工具、安全信息和其他资源，不保证没有瑕疵且不做任何明示或暗示的担保，包括但不限于对适销性、某特定用途方面的适用性或不侵犯任何第三方知识产权的暗示担保。

这些资源可供使用 TI 产品进行设计的熟练开发人员使用。您将自行承担以下全部责任：(1) 针对您的应用选择合适的 TI 产品，(2) 设计、验证并测试您的应用，(3) 确保您的应用满足相应标准以及任何其他安全、安保或其他要求。这些资源如有变更，恕不另行通知。TI 授权您仅可将这些资源用于研发本资源所述的 TI 产品的应用。严禁对这些资源进行其他复制或展示。您无权使用任何其他 TI 知识产权或任何第三方知识产权。您应全额赔偿因在这些资源的使用中对 TI 及其代表造成的任何索赔、损害、成本、损失和债务，TI 对此概不负责。

TI 提供的产品受 TI 的销售条款 (<https://www.ti.com.cn/zh-cn/legal/termsofsale.html>) 或 [ti.com.cn](https://www.ti.com.cn) 上其他适用条款/TI 产品随附的其他适用条款的约束。TI 提供这些资源并不会扩展或以其他方式更改 TI 针对 TI 产品发布的适用的担保或担保免责声明。

邮寄地址：上海市浦东新区世纪大道 1568 号中建大厦 32 楼，邮政编码：200122
Copyright © 2021 德州仪器半导体技术（上海）有限公司