

PAL16L8AM, PAL16L8A-2M, PAL16R4AM, PAL16R4A-2M
 PAL16R6AM, PAL16R6A-2M, PAL16R8AM, PAL16R8A-2M
STANDARD HIGH-SPEED PAL® CIRCUITS

SRPS016 – D2705, FEBRUARY 1984 – REVISED MARCH 1992

- **Choice of Operating Speeds**
 High-Speed, A Devices . . . 25 MHz Min
 Half-Power, A-2 Devices . . . 16 MHz Min
- **Choice of Input/Output Configuration**
- **Package Options Include Both Ceramic DIP and Chip Carrier in Addition to Ceramic Flat Package**

DEVICE	I INPUTS	3-STATE O OUTPUTS	REGISTERED Q OUTPUTS	I/O PORTS
PAL16L8	10	2	0	6
PAL16R4	8	0	4 (3-state buffers)	4
PAL16R6	8	0	6 (3-state buffers)	2
PAL16R8	8	0	8 (3-state buffers)	0

description

These programmable array logic devices feature high speed and a choice of either standard or half-power devices. They combine Advanced Low-Power Schottky technology with proven titanium-tungsten fuses. These devices will provide reliable, high-performance substitutes for conventional TTL logic. Their easy programmability allow for quick design of "custom" functions and typically results in a more compact circuit board. In addition, chip carriers are available for further reduction in board space.

The Half-Power versions offer a choice of operating frequency, switching speeds, and power dissipation. In many cases, these Half-Power devices can result in significant power reduction from an overall system level.

The PAL16' M series is characterized for operation over the full military temperature range of -55°C to 125°C.

PAL16L8'
 J OR W PACKAGE

(TOP VIEW)

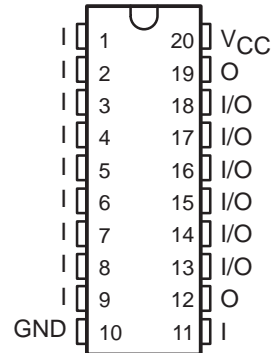

PAL16L8'
 FK PACKAGE

(TOP VIEW)

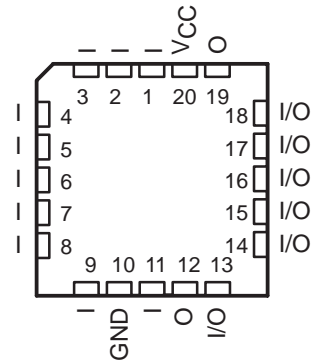

PAL is a registered trademark of Advanced Micro Devices Inc.

PRODUCTION DATA information is current as of publication date. Products conform to specifications per the terms of Texas Instruments standard warranty. Production processing does not necessarily include testing of all parameters.



POST OFFICE BOX 655303 • DALLAS, TEXAS 75265

Copyright © 1992, Texas Instruments Incorporated

PAL16R4AM, PAL16R4A-2M, PAL16R6AM, PAL16R6A-2M, PAL16R8AM, PAL16R8A-2M STANDARD HIGH-SPEED PAL[®] CIRCUITS

SRPS016 – D2705, FEBRUARY 1984 – REVISED MARCH 1992

PAL16R4'
J OR W PACKAGE

(TOP VIEW)

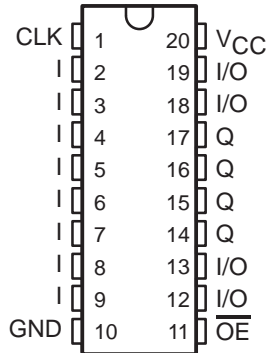

PAL16R4'
FK PACKAGE

(TOP VIEW)

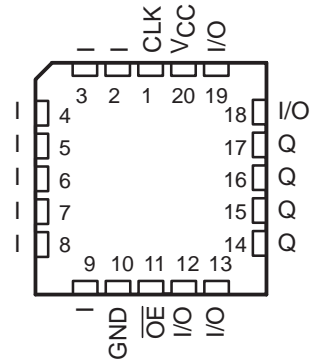

PAL16R6'
J OR W PACKAGE

(TOP VIEW)

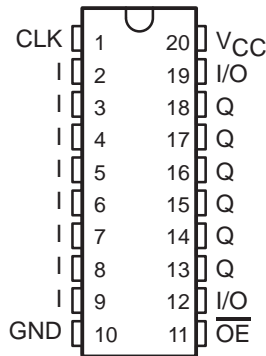

PAL16R6'
FK PACKAGE

(TOP VIEW)

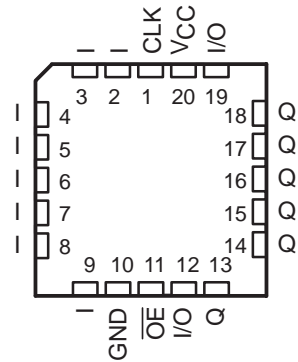

PAL16R8'
J OR W PACKAGE

(TOP VIEW)

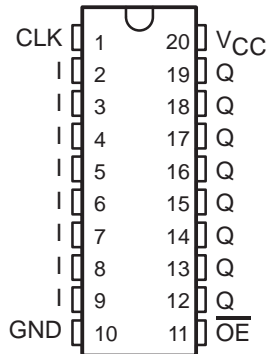

PAL16R8'
FK PACKAGE

(TOP VIEW)

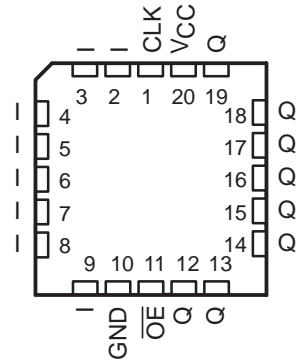

PAL16L8AM, PAL16L8A-2M, PAL16R4AM, PAL16R4A-2M
STANDARD HIGH-SPEED PAL[®] CIRCUITS

SRPS016 – D2705, FEBRUARY 1984 – REVISED MARCH 1992

functional block diagrams (positive logic)

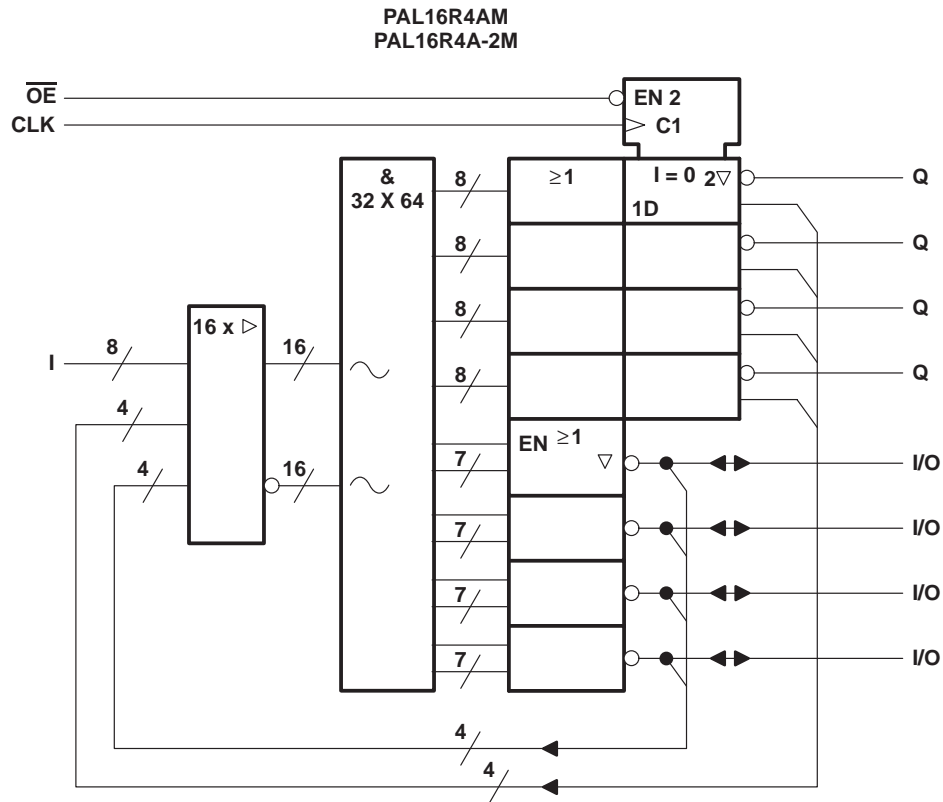
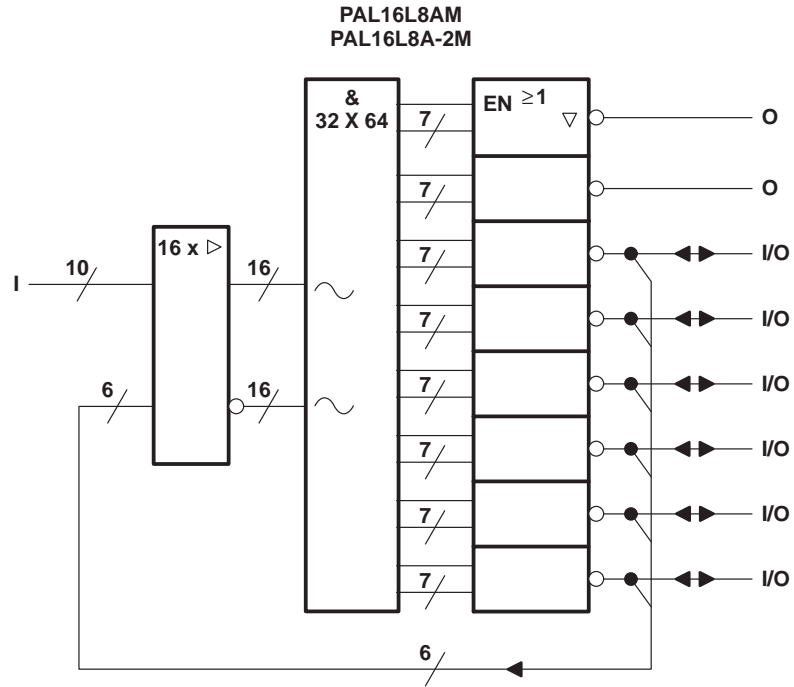

~ denotes fused inputs

PAL16R6AM, PAL16R6A-2M, PAL16R8AM, PAL16R8A-2M STANDARD HIGH-SPEED PAL[®] CIRCUITS

SRPS016 – D2705, FEBRUARY 1984 – REVISED MARCH 1992

functional block diagrams (positive logic)

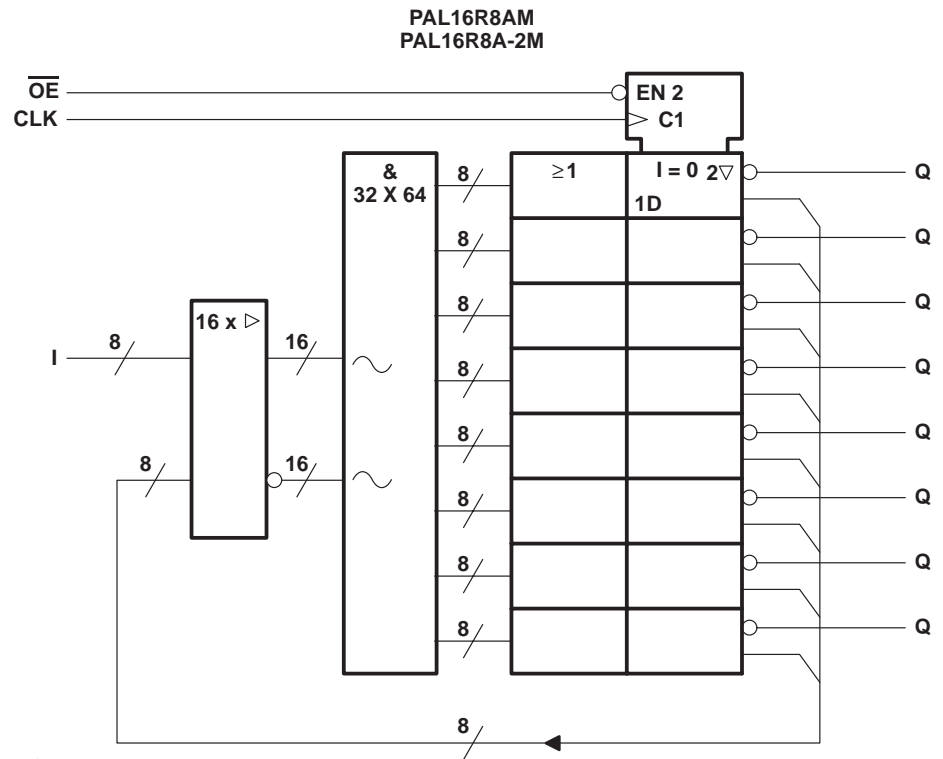
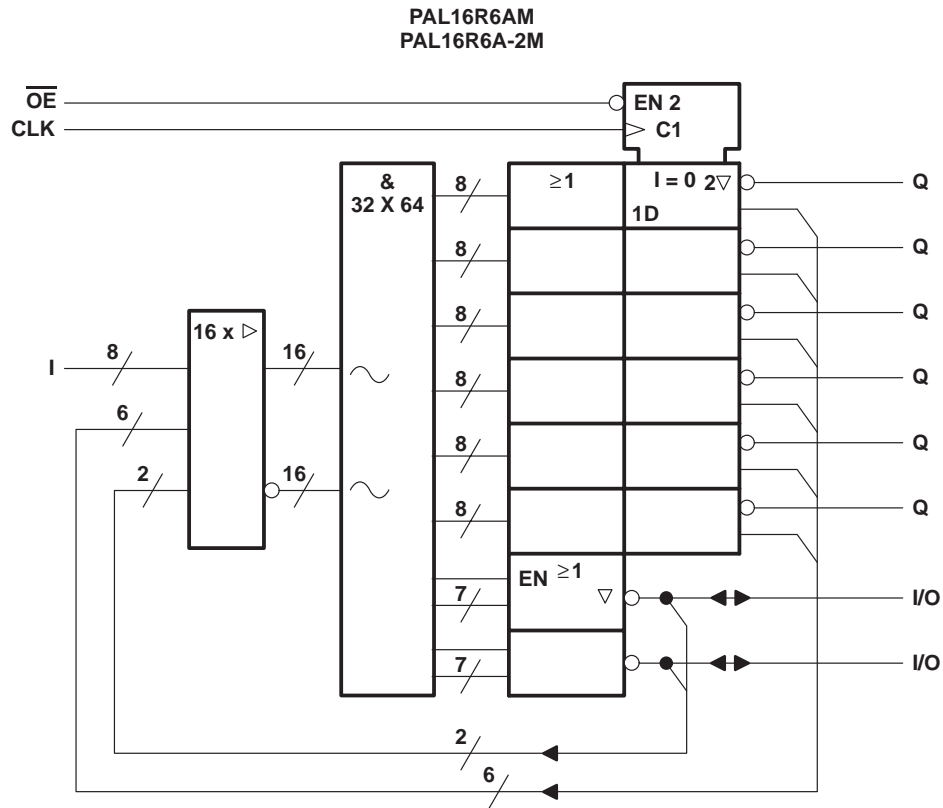

~ denotes fused inputs



POST OFFICE BOX 655303 • DALLAS, TEXAS 75265

logic diagram (positive logic)

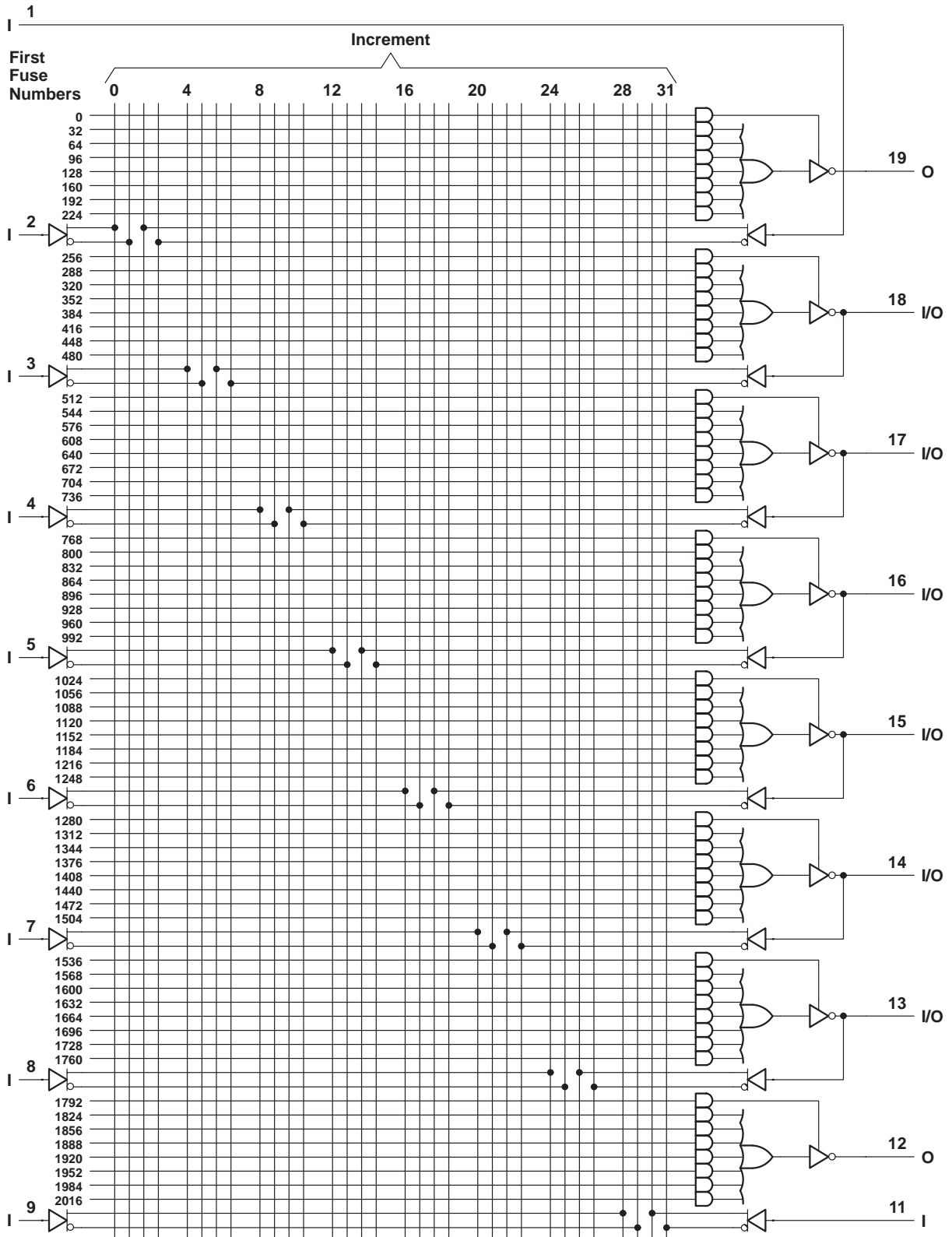

Fuse number = First fuse number + Increment

PAL16R4AM, PAL16R4A-2M STANDARD HIGH-SPEED PAL[®] CIRCUITS

SRPS016 – D2705, FEBRUARY 1984 – REVISED MARCH 1992

logic diagram (positive logic)

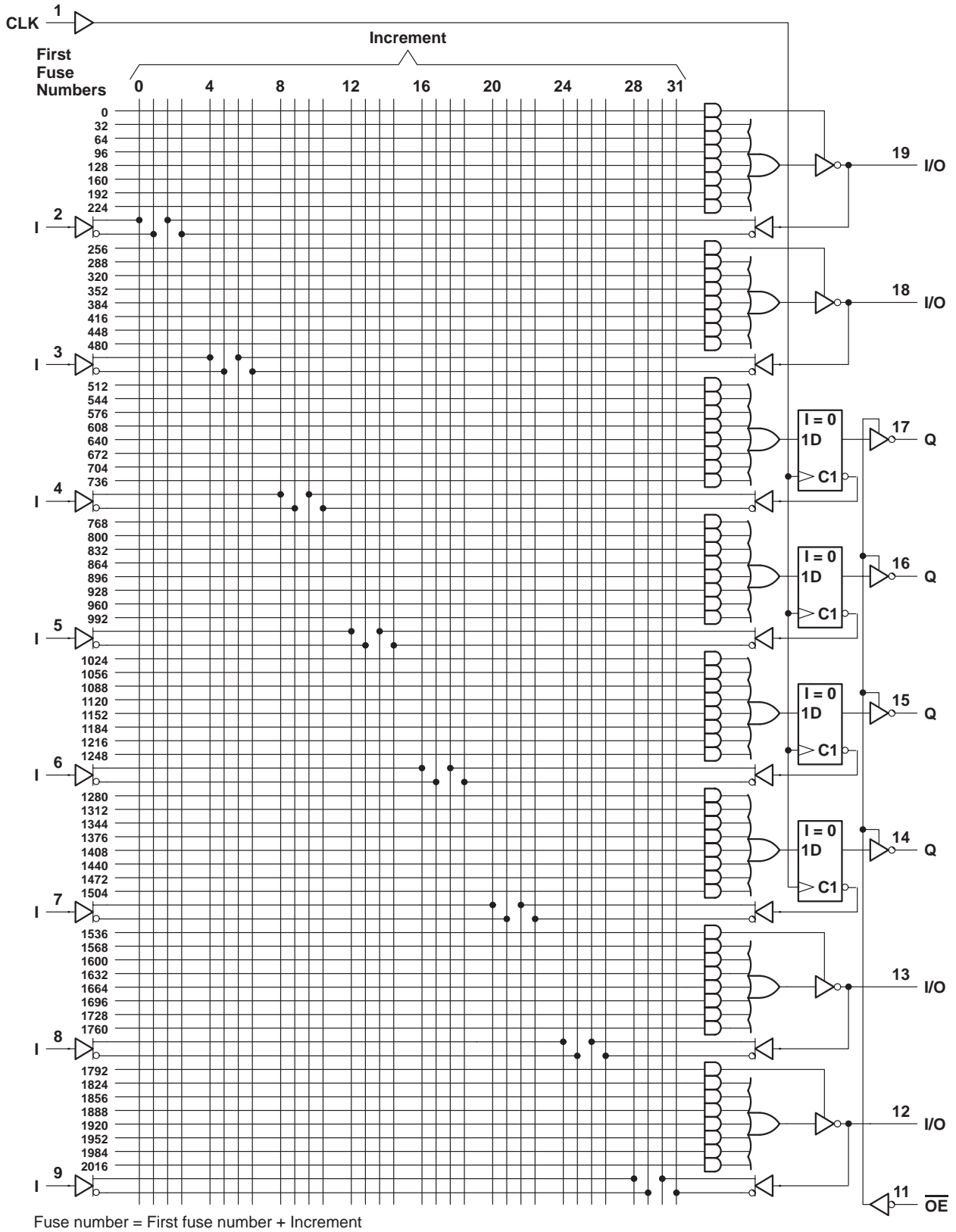

POST OFFICE BOX 655303 • DALLAS, TEXAS 75265

logic diagram (positive logic)

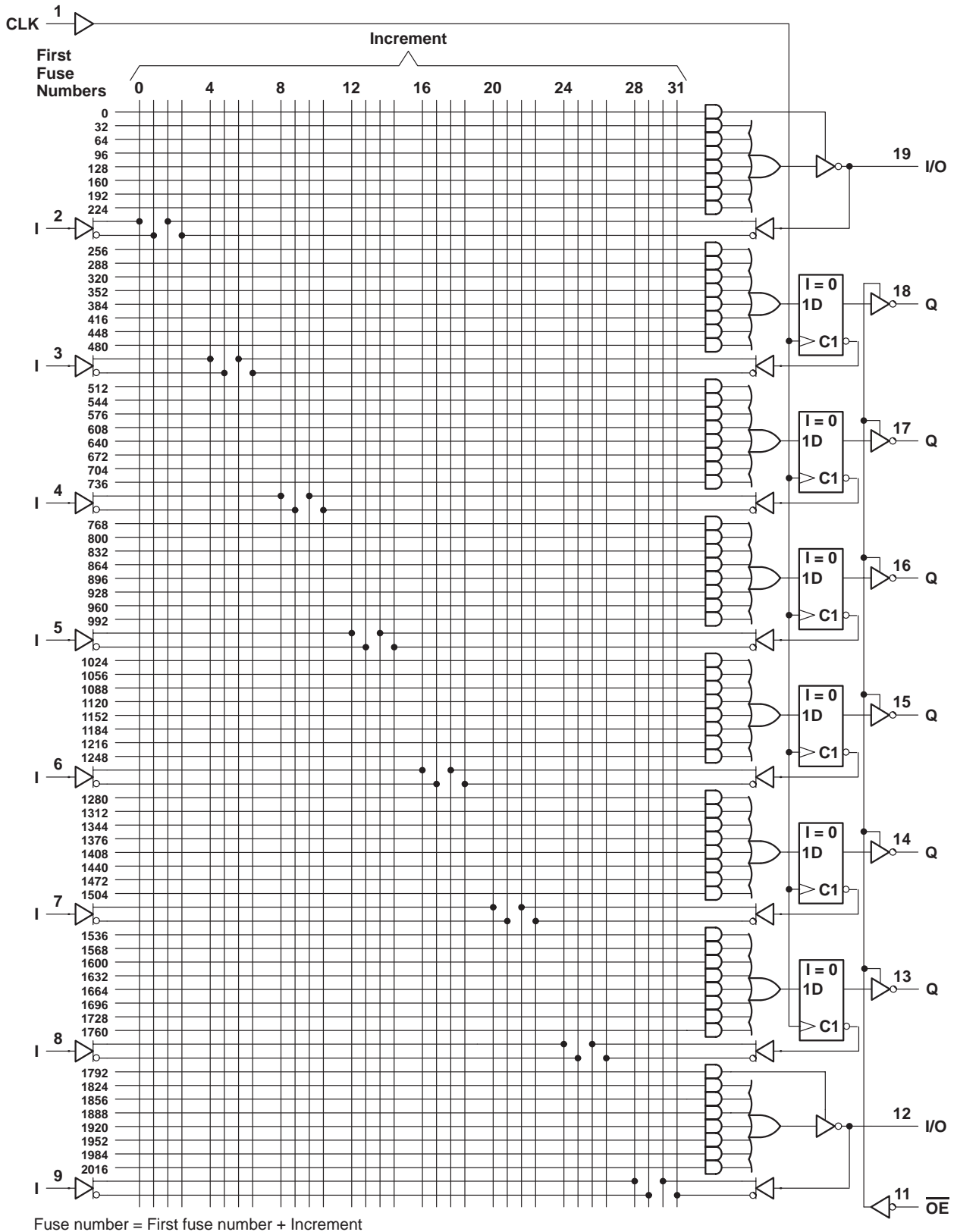

PAL16R8AM, PAL16R8A-2M STANDARD HIGH-SPEED PAL[®] CIRCUITS

SRPS016 – D2705, FEBRUARY 1984 – REVISED MARCH 1992

logic diagram (positive logic)

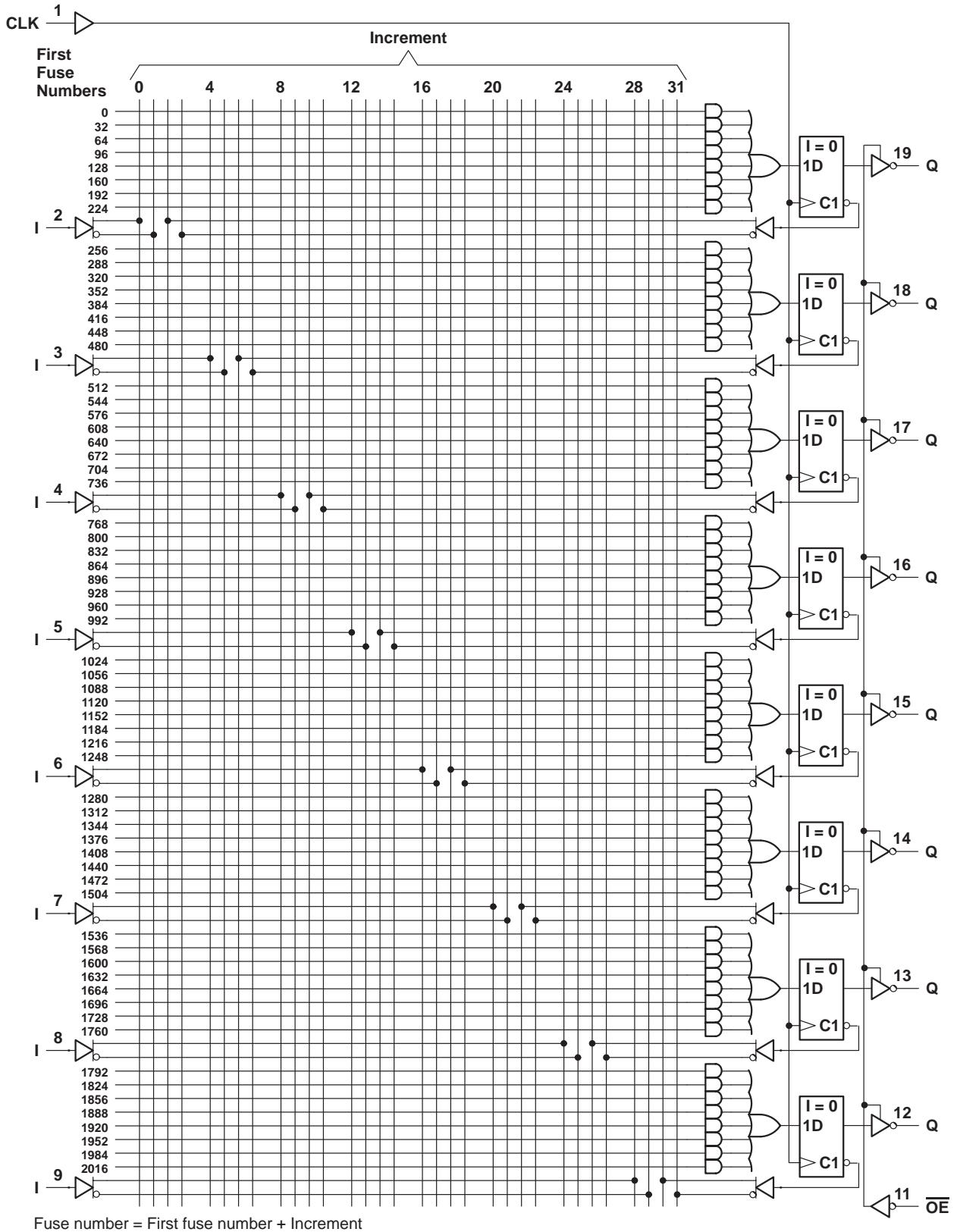

POST OFFICE BOX 655303 • DALLAS, TEXAS 75265

programming information

Texas Instruments programmable logic devices can be programmed using widely available software and inexpensive device programmers.

Complete programming specifications, algorithms, and the latest information on hardware, software, and firmware are available upon request. Information on programmers capable of programming Texas Instruments programmable logic is also available, upon request, from the nearest TI field sales office, local authorized TI distributor, or by calling Texas Instruments at (214) 997-5666.

absolute maximum ratings over operating free-air temperature range (unless otherwise noted)

Supply voltage, V_{CC} (see Note 1)	7 V
Input voltage (see Note 1)	5.5 V
Voltage applied to disabled output (see Note 1)	5.5 V
Operating free-air temperature range	–55°C to 125°C
Storage temperature range	–65°C to 150°C

NOTE 1: These ratings apply except for programming pins during a programming cycle.

recommended operating conditions

		MIN	NOM	MAX	UNIT
V_{CC}	Supply voltage	4.5	5	5.5	V
V_{IH}	High-level input voltage	2		5.5	V
V_{IL}	Low-level input voltage			0.8	V
I_{OH}	High-level output current			–2	mA
I_{OL}	Low-level output current			12	mA
T_A	Operating free-air temperature	–55	25	125	°C

PAL16L8AM, PAL16R4AM, PAL16R6AM, PAL16R8AM STANDARD HIGH-SPEED PAL[®] CIRCUITS

SRPS016 – D2705, FEBRUARY 1984 – REVISED MARCH 1992

electrical characteristics over recommended operating free-air temperature range

PARAMETER		TEST CONDITIONS		MIN	TYP [†]	MAX	UNIT
V _{IK}		V _{CC} = 4.5 V,	I _I = -18 mA			-1.5	V
V _{OH}		V _{CC} = 4.5 V,	I _{OH} = -2 mA	2.4	3.2		V
V _{OL}		V _{CC} = 4.5 V,	I _{OL} = 12 mA		0.25	0.4	V
I _{OZH}	Outputs	V _{CC} = 5.5 V,	V _O = 2.7 V			20	μA
	I/O ports					100	
I _{OZL}	Outputs	V _{CC} = 5.5 V,	V _O = 0.4 V			-20	μA
	I/O ports					-100	
I _I		V _{CC} = 5.5 V,	V _I = 5.5 V			0.2	mA
I _{IH}	I/O Ports	V _{CC} = 5.5 V,	V _I = 2.7 V			100	μA
	All others					25	
I _{IL}	$\overline{\text{OE}}$ input	V _{CC} = 5.5 V,	V _I = 0.4 V			-0.2	mA
	All others					-0.1	
I _{OS} [‡]		V _{CC} = 5.5 V,	V _O = 0.5 V	-30		-250	mA
I _{CC}		V _{CC} = 5.5 V,	V _I = 0, Outputs open		75	180	mA

timing requirements

		MIN	MAX	UNIT
f _{clock}	Clock Frequency	0	25	MHz
t _w	Pulse duration (see Note 2)	Clock high	15	ns
		Clock low	20	
t _{su}	Setup time, input or feedback before CLK [↑]	25		ns
t _h	Hold time, input or feedback after CLK [↑]	0		ns

NOTE 2: The total clock period of clock high and clock low must not exceed clock frequency, f_{clock}. The minimum pulse durations specified are only for clock high or low, but not for both simultaneously.

switching characteristics over recommended ranges of supply voltage and operating free-air temperature (unless otherwise noted)

PARAMETER	FROM (INPUT)	TO (OUTPUT)	TEST CONDITION	MIN	TYP [†]	MAX	UNIT	
f _{max}			R1 = 390 Ω, R2 = 750 Ω, See Figure 1	25	45		MHz	
t _{pd}	I, I/O	O, I/O				15	30	ns
t _{pd}	CLK [↑]	Q			10	20		ns
t _{en}	$\overline{\text{OE}}$ ↓	Q			15	25		ns
t _{dis}	$\overline{\text{OE}}$ ↑	Q			10	25		ns
t _{en}	I, I/O	O, I/O			14	30		ns
t _{dis}	I, I/O	O, I/O			13	30		ns

[†] All typical values are at V_{CC} = 5 V, T_A = 25°C.

[‡] Not more than one output should be shorted at a time and the duration of the short circuit should not exceed one second. Set V_O at 0.5 V to avoid test equipment degradation.



PAL16L8A-2M, PAL16R4A-2M, PAL16R6A-2M, PAL16R8A-2M STANDARD HIGH-SPEED PAL[®] CIRCUITS

SRPS016 – D2705, FEBRUARY 1984 – REVISED MARCH 1992

electrical characteristics over recommended operating free-air temperature range

PARAMETER		TEST CONDITIONS		MIN	TYP [†]	MAX	UNIT
V _{IK}		V _{CC} = 4.5 V,	I _I = -18 mA			-1.5	V
V _{OH}		V _{CC} = 4.5 V,	I _{OH} = -2 mA	2.4	3.2		V
V _{OL}		V _{CC} = 4.5 V,	I _{OL} = 12 mA		0.25	0.4	V
I _{OZH}	Outputs	V _{CC} = 5.5 V,	V _O = 2.7 V			20	μA
	I/O ports					100	
I _{OZL}	Outputs	V _{CC} = 5.5 V,	V _O = 0.4 V			-20	μA
	I/O ports					-100	
I _I		V _{CC} = 5.5 V,	V _I = 5.5 V			0.2	mA
I _{IH}	I/O Ports	V _{CC} = 5.5 V,	V _I = 2.7 V			100	μA
	All others					25	
I _{IL}	$\overline{\text{OE}}$ input	V _{CC} = 5.5 V,	V _I = 0.4 V			-0.2	mA
	All others					-0.1	
I _{OS} [‡]		V _{CC} = 5.5 V,	V _O = 0.5 V	-30		-250	mA
I _{CC}		V _{CC} = 5.5 V,	V _I = 0, Outputs open		75	90	mA

timing requirements

		MIN	MAX	UNIT
f _{clock}	Clock Frequency	0	16	MHz
t _w	Pulse duration (see Note 2)	Clock high	25	ns
		Clock low	25	
t _{su}	Setup time, input or feedback before CLK [↑]	35		ns
t _h	Hold time, input or feedback after CLK [↑]	0		ns

NOTE 2: The total clock period of clock high and clock low must not exceed clock frequency, f_{clock}. The minimum pulse durations specified are only for clock high or low, but not for both simultaneously.

switching characteristics over recommended ranges of supply voltage and operating free-air temperature (unless otherwise noted)

PARAMETER	FROM (INPUT)	TO (OUTPUT)	TEST CONDITION	MIN	TYP [†]	MAX	UNIT	
f _{max}			R1 = 390 Ω, R2 = 750 Ω, See Figure 1	16	25		MHz	
t _{pd}	I, I/O	O, I/O				25	40	ns
t _{pd}	CLK [↑]	Q			11	25		ns
t _{en}	$\overline{\text{OE}}$ ↓	Q			20	25		ns
t _{dis}	$\overline{\text{OE}}$ ↑	Q			11	25		ns
t _{en}	I, I/O	O, I/O			25	40		ns
t _{dis}	I, I/O	O, I/O			25	35		ns

[†] All typical values are at V_{CC} = 5 V, T_A = 25°C.

[‡] Not more than one output should be shorted at a time and the duration of the short circuit should not exceed one second. Set V_O at 0.5 V to avoid test equipment degradation.



PARAMETER MEASUREMENT INFORMATION

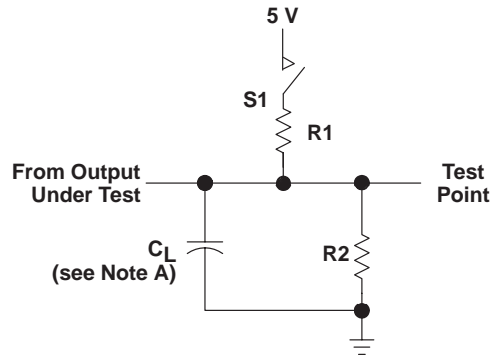

LOAD CIRCUIT FOR 3-STATE OUTPUTS

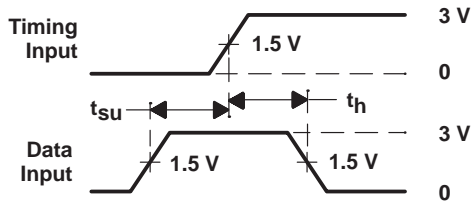

VOLTAGE WAVEFORMS SETUP AND HOLD TIMES

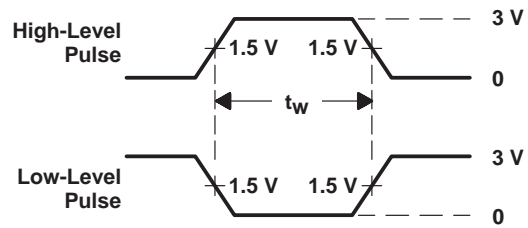

VOLTAGE WAVEFORMS PULSE DURATIONS

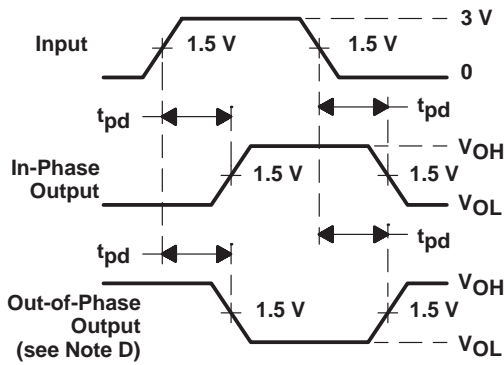

VOLTAGE WAVEFORMS PROPAGATION DELAY TIMES

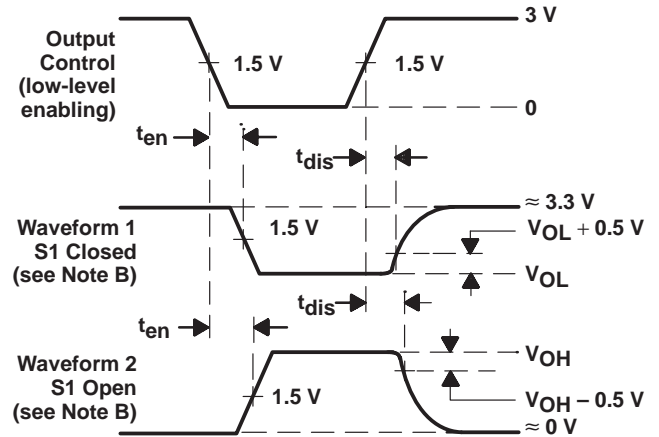

VOLTAGE WAVEFORMS ENABLE AND DISABLE TIMES, 3-STATE OUTPUTS

- NOTES: A. C_L includes probe and jig capacitance and is 50 pF for t_{pd} and t_{en} , 5 pF for t_{dis} .
 B. Waveform 1 is for an output with internal conditions such that the output is low except when disabled by the output control. Waveform 2 is for an output with internal conditions such that the output is high except when disabled by the output control.
 C. All input pulses have the following characteristics: $PRR \leq 10$ MHz, t_r and $t_f \leq 2$ ns, duty cycle = 50%
 D. When measuring propagation delay times of 3-state outputs, switch S1 is closed.
 E. Equivalent loads may be used for testing.

Figure 1. Load Circuit and Voltage Waveforms

PACKAGING INFORMATION

Orderable Device	Status (1)	Package Type	Package Drawing	Pins	Package Qty	Eco Plan (2)	Lead finish/ Ball material (6)	MSL Peak Temp (3)	Op Temp (°C)	Device Marking (4/5)	Samples
81036072A	ACTIVE	LCCC	FK	20	1	Non-RoHS & Green	SNPB	N / A for Pkg Type	-55 to 125	81036072A PAL16L8A MFKB	Samples
8103607RA	ACTIVE	CDIP	J	20	1	Non-RoHS & Green	SNPB	N / A for Pkg Type	-55 to 125	8103607RA PAL16L8AMJB	Samples
8103607SA	ACTIVE	CFP	W	20	1	Non-RoHS & Green	SNPB	N / A for Pkg Type	-55 to 125	8103607SA PAL16L8AMWB	Samples
81036082A	ACTIVE	LCCC	FK	20	1	Non-RoHS & Green	SNPB	N / A for Pkg Type	-55 to 125	81036082A PAL16R8A MFKB	Samples
8103608RA	ACTIVE	CDIP	J	20	1	Non-RoHS & Green	SNPB	N / A for Pkg Type	-55 to 125	8103608RA PAL16R8AMJB	Samples
81036092A	ACTIVE	LCCC	FK	20	1	Non-RoHS & Green	SNPB	N / A for Pkg Type	-55 to 125	81036092A PAL16R6A MFKB	Samples
8103609RA	ACTIVE	CDIP	J	20	1	Non-RoHS & Green	SNPB	N / A for Pkg Type	-55 to 125	8103609RA PAL16R6AMJB	Samples
81036102A	ACTIVE	LCCC	FK	20	1	Non-RoHS & Green	SNPB	N / A for Pkg Type	-55 to 125	81036102A PAL16R4A MFKB	Samples
8103610RA	ACTIVE	CDIP	J	20	1	Non-RoHS & Green	SNPB	N / A for Pkg Type	-55 to 125	8103610RA PAL16R4AMJB	Samples
8103610SA	ACTIVE	CFP	W	20	1	Non-RoHS & Green	SNPB	N / A for Pkg Type	-55 to 125	8103610SA PAL16R4AMWB	Samples
81036112A	ACTIVE	LCCC	FK	20	1	Non-RoHS & Green	SNPB	N / A for Pkg Type	-55 to 125	81036112A PAL16L8A- 2MFKB	Samples
8103611RA	ACTIVE	CDIP	J	20	1	Non-RoHS & Green	SNPB	N / A for Pkg Type	-55 to 125	8103611RA PAL16L8A-2MJB	Samples
81036142A	ACTIVE	LCCC	FK	20	1	Non-RoHS & Green	SNPB	N / A for Pkg Type	-55 to 125	81036142A PAL16R4A- 2MFKB	Samples
PAL16L8A-2MFKB	ACTIVE	LCCC	FK	20	1	Non-RoHS & Green	SNPB	N / A for Pkg Type	-55 to 125	81036112A PAL16L8A-	Samples

Orderable Device	Status (1)	Package Type	Package Drawing	Pins	Package Qty	Eco Plan (2)	Lead finish/ Ball material (6)	MSL Peak Temp (3)	Op Temp (°C)	Device Marking (4/5)	Samples
										2MFKB	
PAL16L8A-2MJ	ACTIVE	CDIP	J	20	1	Non-RoHS & Green	SNPB	N / A for Pkg Type	-55 to 125	PAL16L8A-2MJ	Samples
PAL16L8A-2MJB	ACTIVE	CDIP	J	20	1	Non-RoHS & Green	SNPB	N / A for Pkg Type	-55 to 125	8103611RA PAL16L8A-2MJB	Samples
PAL16L8AMFKB	ACTIVE	LCCC	FK	20	1	Non-RoHS & Green	SNPB	N / A for Pkg Type	-55 to 125	81036072A PAL16L8A MFKB	Samples
PAL16L8AMJ	ACTIVE	CDIP	J	20	1	Non-RoHS & Green	SNPB	N / A for Pkg Type	-55 to 125	PAL16L8AMJ	Samples
PAL16L8AMJB	ACTIVE	CDIP	J	20	1	Non-RoHS & Green	SNPB	N / A for Pkg Type	-55 to 125	8103607RA PAL16L8AMJB	Samples
PAL16L8AMWB	ACTIVE	CFP	W	20	1	Non-RoHS & Green	SNPB	N / A for Pkg Type	-55 to 125	8103607SA PAL16L8AMWB	Samples
PAL16R4A-2MFKB	ACTIVE	LCCC	FK	20	1	Non-RoHS & Green	SNPB	N / A for Pkg Type	-55 to 125	81036142A PAL16R4A- 2MFKB	Samples
PAL16R4A-2MJ	NRND	CDIP	J	20	1	Non-RoHS & Green	SNPB	N / A for Pkg Type	-55 to 125	PAL16R4A-2MJ	
PAL16R4AMFKB	ACTIVE	LCCC	FK	20	1	Non-RoHS & Green	SNPB	N / A for Pkg Type	-55 to 125	81036102A PAL16R4A MFKB	Samples
PAL16R4AMJ	ACTIVE	CDIP	J	20	1	Non-RoHS & Green	SNPB	N / A for Pkg Type	-55 to 125	PAL16R4AMJ	Samples
PAL16R4AMJB	ACTIVE	CDIP	J	20	1	Non-RoHS & Green	SNPB	N / A for Pkg Type	-55 to 125	8103610RA PAL16R4AMJB	Samples
PAL16R4AMWB	ACTIVE	CFP	W	20	1	Non-RoHS & Green	SNPB	N / A for Pkg Type	-55 to 125	8103610SA PAL16R4AMWB	Samples
PAL16R6AMFKB	ACTIVE	LCCC	FK	20	1	Non-RoHS & Green	SNPB	N / A for Pkg Type	-55 to 125	81036092A PAL16R6A MFKB	Samples
PAL16R6AMJ	ACTIVE	CDIP	J	20	1	Non-RoHS & Green	SNPB	N / A for Pkg Type	-55 to 125	PAL16R6AMJ	Samples
PAL16R6AMJB	ACTIVE	CDIP	J	20	1	Non-RoHS & Green	SNPB	N / A for Pkg Type	-55 to 125	8103609RA PAL16R6AMJB	Samples

Orderable Device	Status (1)	Package Type	Package Drawing	Pins	Package Qty	Eco Plan (2)	Lead finish/ Ball material (6)	MSL Peak Temp (3)	Op Temp (°C)	Device Marking (4/5)	Samples
PAL16R8AMFKB	ACTIVE	LCCC	FK	20	1	Non-RoHS & Green	SNPB	N / A for Pkg Type	-55 to 125	81036082A PAL16R8A MFKB	Samples
PAL16R8AMJ	ACTIVE	CDIP	J	20	1	Non-RoHS & Green	SNPB	N / A for Pkg Type	-55 to 125	PAL16R8AMJ	Samples
PAL16R8AMJB	ACTIVE	CDIP	J	20	1	Non-RoHS & Green	SNPB	N / A for Pkg Type	-55 to 125	8103608RA PAL16R8AMJB	Samples

(1) The marketing status values are defined as follows:

ACTIVE: Product device recommended for new designs.

LIFEBUY: TI has announced that the device will be discontinued, and a lifetime-buy period is in effect.

NRND: Not recommended for new designs. Device is in production to support existing customers, but TI does not recommend using this part in a new design.

PREVIEW: Device has been announced but is not in production. Samples may or may not be available.

OBSOLETE: TI has discontinued the production of the device.

(2) **RoHS:** TI defines "RoHS" to mean semiconductor products that are compliant with the current EU RoHS requirements for all 10 RoHS substances, including the requirement that RoHS substance do not exceed 0.1% by weight in homogeneous materials. Where designed to be soldered at high temperatures, "RoHS" products are suitable for use in specified lead-free processes. TI may reference these types of products as "Pb-Free".

RoHS Exempt: TI defines "RoHS Exempt" to mean products that contain lead but are compliant with EU RoHS pursuant to a specific EU RoHS exemption.

Green: TI defines "Green" to mean the content of Chlorine (Cl) and Bromine (Br) based flame retardants meet JS709B low halogen requirements of <=1000ppm threshold. Antimony trioxide based flame retardants must also meet the <=1000ppm threshold requirement.

(3) MSL, Peak Temp. - The Moisture Sensitivity Level rating according to the JEDEC industry standard classifications, and peak solder temperature.

(4) There may be additional marking, which relates to the logo, the lot trace code information, or the environmental category on the device.

(5) Multiple Device Markings will be inside parentheses. Only one Device Marking contained in parentheses and separated by a "~" will appear on a device. If a line is indented then it is a continuation of the previous line and the two combined represent the entire Device Marking for that device.

(6) Lead finish/Ball material - Orderable Devices may have multiple material finish options. Finish options are separated by a vertical ruled line. Lead finish/Ball material values may wrap to two lines if the finish value exceeds the maximum column width.

Important Information and Disclaimer:The information provided on this page represents TI's knowledge and belief as of the date that it is provided. TI bases its knowledge and belief on information provided by third parties, and makes no representation or warranty as to the accuracy of such information. Efforts are underway to better integrate information from third parties. TI has taken and continues to take reasonable steps to provide representative and accurate information but may not have conducted destructive testing or chemical analysis on incoming materials and chemicals. TI and TI suppliers consider certain information to be proprietary, and thus CAS numbers and other limited information may not be available for release.

In no event shall TI's liability arising out of such information exceed the total purchase price of the TI part(s) at issue in this document sold by TI to Customer on an annual basis.

OTHER QUALIFIED VERSIONS OF PAL16L8A-2M, PAL16L8AM, PAL16R4AM, PAL16R6AM, PAL16R8AM :

- Catalog : [PAL16L8A-2](#), [PAL16L8A](#), [PAL16R4A](#), [PAL16R6A](#), [PAL16R8A](#)

NOTE: Qualified Version Definitions:

- Catalog - TI's standard catalog product

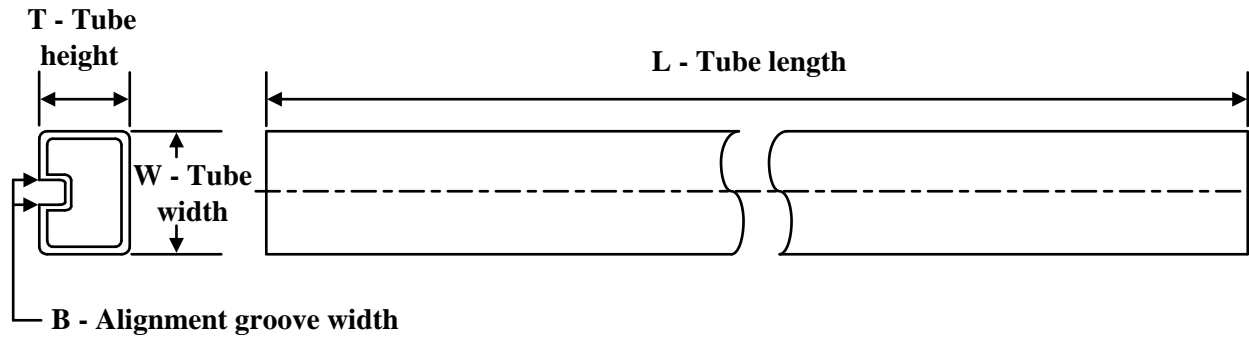
TUBE

*All dimensions are nominal

Device	Package Name	Package Type	Pins	SPQ	L (mm)	W (mm)	T (μm)	B (mm)
81036072A	FK	LCCC	20	1	506.98	12.06	2030	NA
8103607SA	W	CFP	20	1	506.98	26.16	6220	NA
81036082A	FK	LCCC	20	1	506.98	12.06	2030	NA
81036092A	FK	LCCC	20	1	506.98	12.06	2030	NA
81036102A	FK	LCCC	20	1	506.98	12.06	2030	NA
8103610SA	W	CFP	20	1	506.98	26.16	6220	NA
81036112A	FK	LCCC	20	1	506.98	12.06	2030	NA
81036142A	FK	LCCC	20	1	506.98	12.06	2030	NA
PAL16L8A-2MFKB	FK	LCCC	20	1	506.98	12.06	2030	NA
PAL16L8AMFKB	FK	LCCC	20	1	506.98	12.06	2030	NA
PAL16L8AMWB	W	CFP	20	1	506.98	26.16	6220	NA
PAL16R4A-2MFKB	FK	LCCC	20	1	506.98	12.06	2030	NA
PAL16R4AMFKB	FK	LCCC	20	1	506.98	12.06	2030	NA
PAL16R4AMWB	W	CFP	20	1	506.98	26.16	6220	NA
PAL16R6AMFKB	FK	LCCC	20	1	506.98	12.06	2030	NA
PAL16R8AMFKB	FK	LCCC	20	1	506.98	12.06	2030	NA

W (R-GDFP-F20)

CERAMIC DUAL FLATPACK



- NOTES:
- A. All linear dimensions are in inches (millimeters).
 - B. This drawing is subject to change without notice.
 - C. This package can be hermetically sealed with a ceramic lid using glass frit.
 - D. Index point is provided on cap for terminal identification only.
 - E. Falls within Mil-Std 1835 GDFP2-F20

FK (S-CQCC-N**)

LEADLESS CERAMIC CHIP CARRIER

28 TERMINAL SHOWN



NO. OF TERMINALS **	A		B	
	MIN	MAX	MIN	MAX
20	0.342 (8,69)	0.358 (9,09)	0.307 (7,80)	0.358 (9,09)
28	0.442 (11,23)	0.458 (11,63)	0.406 (10,31)	0.458 (11,63)
44	0.640 (16,26)	0.660 (16,76)	0.495 (12,58)	0.560 (14,22)
52	0.740 (18,78)	0.761 (19,32)	0.495 (12,58)	0.560 (14,22)
68	0.938 (23,83)	0.962 (24,43)	0.850 (21,6)	0.858 (21,8)
84	1.141 (28,99)	1.165 (29,59)	1.047 (26,6)	1.063 (27,0)



4040140/D 01/11

- NOTES:
- All linear dimensions are in inches (millimeters).
 - This drawing is subject to change without notice.
 - This package can be hermetically sealed with a metal lid.
 - Falls within JEDEC MS-004

IMPORTANT NOTICE AND DISCLAIMER

TI PROVIDES TECHNICAL AND RELIABILITY DATA (INCLUDING DATA SHEETS), DESIGN RESOURCES (INCLUDING REFERENCE DESIGNS), APPLICATION OR OTHER DESIGN ADVICE, WEB TOOLS, SAFETY INFORMATION, AND OTHER RESOURCES "AS IS" AND WITH ALL FAULTS, AND DISCLAIMS ALL WARRANTIES, EXPRESS AND IMPLIED, INCLUDING WITHOUT LIMITATION ANY IMPLIED WARRANTIES OF MERCHANTABILITY, FITNESS FOR A PARTICULAR PURPOSE OR NON-INFRINGEMENT OF THIRD PARTY INTELLECTUAL PROPERTY RIGHTS.

These resources are intended for skilled developers designing with TI products. You are solely responsible for (1) selecting the appropriate TI products for your application, (2) designing, validating and testing your application, and (3) ensuring your application meets applicable standards, and any other safety, security, regulatory or other requirements.

These resources are subject to change without notice. TI grants you permission to use these resources only for development of an application that uses the TI products described in the resource. Other reproduction and display of these resources is prohibited. No license is granted to any other TI intellectual property right or to any third party intellectual property right. TI disclaims responsibility for, and you will fully indemnify TI and its representatives against, any claims, damages, costs, losses, and liabilities arising out of your use of these resources.

TI's products are provided subject to [TI's Terms of Sale](#) or other applicable terms available either on ti.com or provided in conjunction with such TI products. TI's provision of these resources does not expand or otherwise alter TI's applicable warranties or warranty disclaimers for TI products.

TI objects to and rejects any additional or different terms you may have proposed.

Mailing Address: Texas Instruments, Post Office Box 655303, Dallas, Texas 75265
Copyright © 2022, Texas Instruments Incorporated