

SN75LBC179, SN65LBC179, SN65LBC179Q LOW-POWER DIFFERENTIAL LINE DRIVER AND RECEIVER PAIRS

SLLS173F – JANUARY 1994 – REVISED APRIL 2006

- Designed for High-Speed Multipoint Data Transmission Over Long Cables
- Operates With Pulse Widths as Low as 30 ns
- Low Supply Current . . . 5 mA Max
- Meets or Exceeds the Standard Requirements of ANSI RS-485 and ISO 8482:1987(E)
- Common-Mode Voltage Range of –7 V to 12 V
- Positive- and Negative-Output Current Limiting
- Driver Thermal Shutdown Protection
- Pin Compatible With the SN75179B

description

The SN65LBC179, SN65LBC179Q, and SN75LBC179 differential driver and receiver pairs are monolithic integrated circuits designed for bidirectional data communication over long cables that take on the characteristics of transmission lines. They are balanced, or differential, voltage mode devices that meet or exceed the requirements of industry standards ANSI RS-485 and ISO 8482:1987(E). Both devices are designed using TI's proprietary LinBiCMOS™ with the low power consumption of CMOS and the precision and robustness of bipolar transistors in the same circuit.

The SN65LBC179, SN65LBC179Q, and SN75LBC179 combine a differential line driver and differential line receiver and operate from a single 5-V supply. The driver differential outputs and the receiver differential inputs are connected to separate terminals for full-duplex operation and are designed to present minimum loading to the bus when powered off ($V_{CC} = 0$). These parts feature a wide common-mode voltage range making them suitable for point-to-point or multipoint data bus applications. The devices also provide positive- and negative-current limiting and thermal shutdown for protection from line fault conditions. The line driver shuts down at a junction temperature of approximately 172°C.

D OR P PACKAGE
(TOP VIEW)

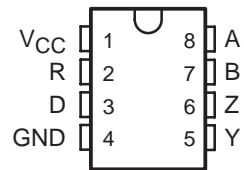

Function Tables

DRIVER

INPUT D	OUTPUTS	
	Y	Z
H	H	L
L	L	H

RECEIVER

DIFFERENTIAL INPUTS A – B	OUTPUT R
$V_{ID} \geq 0.2 \text{ V}$	H
$-0.2 \text{ V} < V_{ID} < 0.2 \text{ V}$?
$V_{ID} \leq -0.2 \text{ V}$	L
Open circuit	H

H = high level, L = low level,
? = indeterminate

logic symbol†

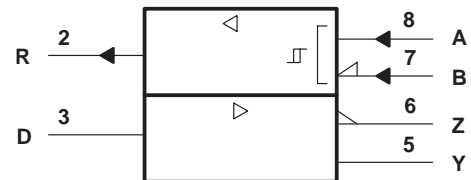

† This symbol is in accordance with ANSI/IEEE Std 91-1984 and IEC Publication 617-12.

logic diagram (positive logic)

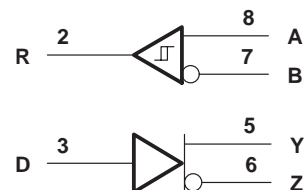

Please be aware that an important notice concerning availability, standard warranty, and use in critical applications of Texas Instruments semiconductor products and disclaimers thereto appears at the end of this data sheet.

LinBiCMOS is a trademark of Texas Instruments.

PRODUCTION DATA information is current as of publication date. Products conform to specifications per the terms of Texas Instruments standard warranty. Production processing does not necessarily include testing of all parameters.



POST OFFICE BOX 655303 • DALLAS, TEXAS 75265

Copyright © 1994 – 2006, Texas Instruments Incorporated

SN75LBC179, SN65LBC179, SN65LBC179Q LOW-POWER DIFFERENTIAL LINE DRIVER AND RECEIVER PAIRS

SLLS173F – JANUARY 1994 – REVISED APRIL 2006

description (continued)

The SN65LBC179, SN65LBC179Q, and SN75LBC179 are available in the 8-pin dual-in-line and small-outline packages. The SN75LBC179 is characterized for operation over the commercial temperature range of 0°C to 70°C. The SN65LBC179 is characterized over the industrial temperature range of -40°C to 85°C. The SN65LBC179Q is characterized over the extended industrial or automotive temperature range of -40°C to 125°C.

schematics of inputs and outputs

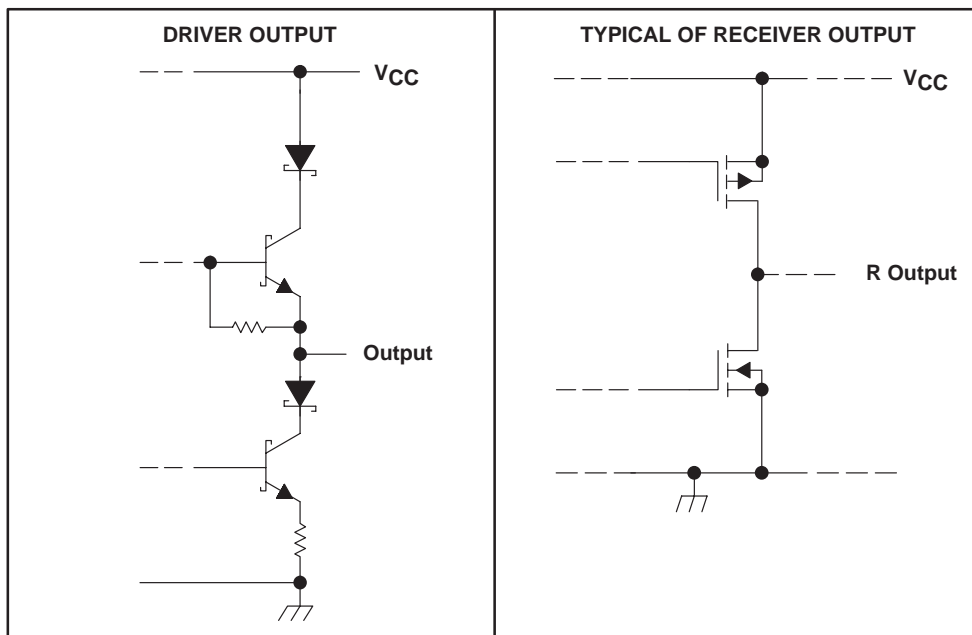
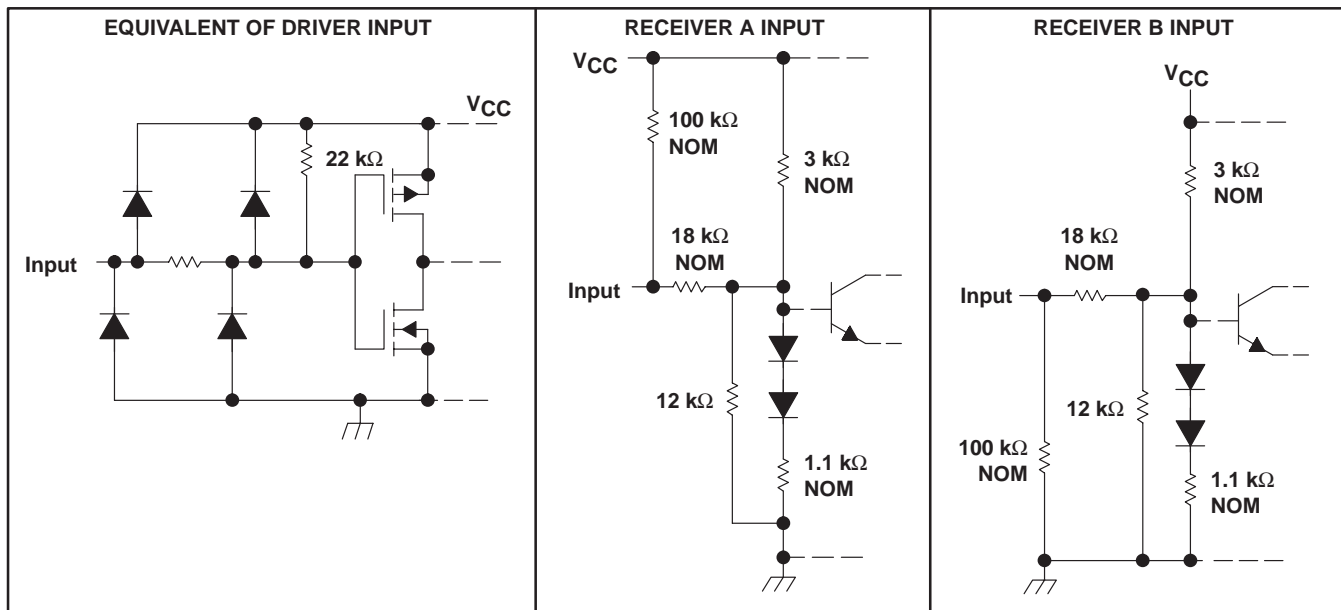

SN75LBC179, SN65LBC179, SN65LBC179Q

LOW-POWER DIFFERENTIAL LINE DRIVER AND RECEIVER PAIRS

SLLS173F – JANUARY 1994 – REVISED APRIL 2006

absolute maximum ratings†

Supply voltage range, V_{CC}	–0.3 V to 7 V
Voltage range at A, B, Y, or Z (see Note 1)	–10 V to 15 V
Voltage range at D or R (see Note 1)	–0.3 V to $V_{CC} + 0.5$ V
Receiver output current, I_O	±10 mA
Continuous total power dissipation (see Note 2)	Internally limited
Total power dissipation	See Dissipation Rating Table

† Stresses beyond those listed under “absolute maximum ratings” may cause permanent damage to the device. These are stress ratings only, and functional operation of the device at these or any other conditions beyond those indicated under “recommended operating conditions” is not implied. Exposure to absolute-maximum-rated conditions for extended periods may affect device reliability.

- NOTES: 1. All voltage values are with respect to GND.
 2. The maximum operating junction temperature is internally limited. Uses the dissipation rating table to operate below this temperature.

recommended operating conditions

		MIN	NOM	MAX	UNIT
Supply voltage, V_{CC}		4.75	5	5.25	V
High-level input voltage, V_{IH}	D	2			V
Low-level input voltage, V_{IL}	D			0.8	V
Differential input voltage, V_{ID}		–6‡		6	V
Voltage at any bus terminal (separately or common-mode), V_O , V_I , or V_{IC}	A, B, Y, or Z	–7		12	V
High-level output current, I_{OH}	Y or Z			–60	mA
	R			–8	
Low-level output current, I_{OL}	Y or Z			60	mA
	R			8	
Junction temperature, T_J				140	°C
Operating free-air temperature, T_A	SN65LBC179	–40		85	°C
	SN65LBC179Q	–40		125	
	SN75LBC179	0		70	

‡ The algebraic convention, in which the least positive (most negative) limit is designated as minimum, is used in this data sheet for differential input voltage, voltage at any bus terminal (separately or common mode), operating temperature, input threshold voltage, and common-mode output voltage.

DISSIPATION RATING TABLE

PACKAGE	THERMAL MODEL	$T_A < 25^\circ\text{C}$	DERATING FACTOR	$T_A = 70^\circ\text{C}$	$T_A = 85^\circ\text{C}$
		POWER RATING	ABOVE $T_A = 25^\circ\text{C}$	POWER RATING	POWER RATING
D	Low K†	526 mW	5.0 mW/°C	301 mW	226 mW
	High K‡	882 mW	8.4 mW/°C	504 mW	378 mW
P		840 mW	8.0 mW/°C	480 mW	360 mW

† In accordance with the low effective thermal conductivity metric definitions of EIA/JESD 51–3.

‡ In accordance with the high effective thermal conductivity metric definitions of EIA/JESD 51–7.



SN75LBC179, SN65LBC179, SN65LBC179Q LOW-POWER DIFFERENTIAL LINE DRIVER AND RECEIVER PAIRS

SLLS173F – JANUARY 1994 – REVISED APRIL 2006

DRIVER SECTION

electrical characteristics over recommended operating conditions (unless otherwise noted)

PARAMETER		TEST CONDITIONS		MIN	TYP†	MAX	UNIT
V_{IK}	Input clamp voltage	$I_I = -18 \text{ mA}$				-1.5	V
$ V_{OD} $	Differential output voltage (see Note 3)	$R_L = 54 \Omega$, See Figure 1	SN65LBC179, SN65LBC179Q	1.1	2.2	5	V
			SN75LBC179	1.5	2.2	5	
		$R_L = 60 \Omega$, See Figure 2	SN65LBC179, SN65LBC179Q	1.1	2.2	5	
			SN75LBC179	1.5	2.2	5	
$\Delta V_{OD} $	Change in magnitude of differential output voltage (see Note 4)	See Figures 1 and 2				± 0.2	V
V_{OC}	Common-mode output voltage	$R_L = 54 \Omega$, See Figure 1		1	2.5	3	V
$\Delta V_{OC} $	Change in magnitude of common-mode output voltage (see Note 4)					± 0.2	V
I_O	Output current with power off	$V_{CC} = 0$, $V_O = -7 \text{ V to } 12 \text{ V}$				± 100	μA
I_{IH}	High-level input current	$V_I = 2.4 \text{ V}$				-100	μA
I_{IL}	Low-level input current	$V_I = 0.4 \text{ V}$				-100	μA
I_{OS}	Short-circuit output current	$-7 \text{ V} \leq V_O \leq 12 \text{ V}$				± 250	mA
I_{CC}	Supply current	No load	SN65LBC179, SN75LBC179		4.2	5	mA
			SN65LBC179Q		4.2	7	mA

† All typical values are at $V_{CC} = 5 \text{ V}$ and $T_A = 25^\circ\text{C}$.

NOTES: 3. The minimum V_{OD} specification of the SN65179 may not fully comply with ANSI RS-485 at operating temperatures below 0°C . System designers should take the possibly lower output signal into account in determining the maximum signal transmission distance.

4. $\Delta|V_{OD}|$ and $\Delta|V_{OC}|$ are the changes in the steady-state magnitude of V_{OD} and V_{OC} , respectively, that occur when the input is changed from a high level to a low level.

switching characteristics, $V_{CC} = 5 \text{ V}$, $T_A = 25^\circ\text{C}$

PARAMETER		TEST CONDITIONS		MIN	MAX	UNIT
$t_{d(OD)}$	Differential-output delay time	$R_L = 54 \Omega$, See Figure 3		7	18	ns
$t_{t(OD)}$	Differential transition time				5	20



SN75LBC179, SN65LBC179, SN65LBC179Q LOW-POWER DIFFERENTIAL LINE DRIVER AND RECEIVER PAIRS

SLLS173F – JANUARY 1994 – REVISED APRIL 2006

RECEIVER SECTION

electrical characteristics over recommended operating conditions (unless otherwise noted)

PARAMETER	TEST CONDITIONS	MIN	TYP	MAX	UNIT
V_{IT+} Positive-going input threshold voltage	$I_O = -8 \text{ mA}$			0.2	V
V_{IT-} Negative-going input threshold voltage	$I_O = 8 \text{ mA}$	-0.2			V
V_{hys} Hysteresis voltage ($V_{IT+} - V_{IT-}$)			45		mV
V_{OH} High-level output voltage	$V_{ID} = 200 \text{ mV}$, $I_{OH} = -8 \text{ mA}$	3.5	4.5		V
V_{OL} Low-level output voltage	$V_{ID} = -200 \text{ mV}$, $I_{OL} = 8 \text{ mA}$		0.3	0.5	V
I_I Bus input current	$V_I = 12 \text{ V}$, Other inputs at 0 V, $V_{CC} = 5 \text{ V}$	SN65LBC179, SN75LBC179	0.7	1	mA
		SN65LBC179Q	0.7	1.2	mA
	$V_I = 12 \text{ V}$, Other inputs at 0 V, $V_{CC} = 0 \text{ V}$	SN65LBC179, SN75LBC179	0.8	1	mA
		SN65LBC179Q	0.8	1.2	mA
	$V_I = -7 \text{ V}$, Other inputs at 0 V, $V_{CC} = 5 \text{ V}$	SN65LBC179, SN75LBC179	-0.5	-0.8	mA
		SN65LBC179Q	-0.5	-1.0	mA
	$V_I = -7 \text{ V}$, Other inputs at 0 V, $V_{CC} = 0 \text{ V}$	SN65LBC179, SN75LBC179	-0.5	-0.8	mA
		SN65LBC179Q	-0.5	-1.0	mA

switching characteristics, $V_{CC} = 5 \text{ V}$, $T_A = 25^\circ\text{C}$

PARAMETER	TEST CONDITIONS	MIN	TYP	MAX	UNIT
t_{PHL} Propagation delay time, high- to low-level output	$V_{ID} = -1.5 \text{ V to } 1.5 \text{ V}$, See Figure 4	15		30	ns
t_{PLH} Propagation delay time, low- to high-level output		15		30	ns
$t_{sk(p)}$ Pulse skew ($ t_{PHL} - t_{PLH} $)	See Figure 4		3	6	ns
t_t Transition time			3	5	ns

PARAMETER MEASUREMENT INFORMATION

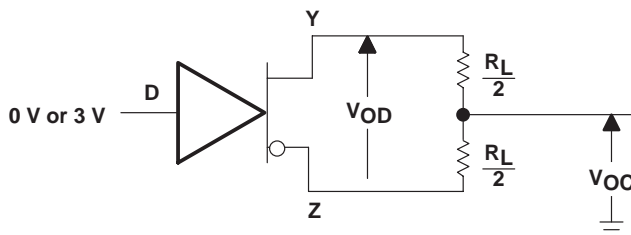

Figure 1. Differential and Common-Mode Output Voltage Test Circuit

SN75LBC179, SN65LBC179, SN65LBC179Q LOW-POWER DIFFERENTIAL LINE DRIVER AND RECEIVER PAIRS

SLLS173F – JANUARY 1994 – REVISED APRIL 2006

PARAMETER MEASUREMENT INFORMATION

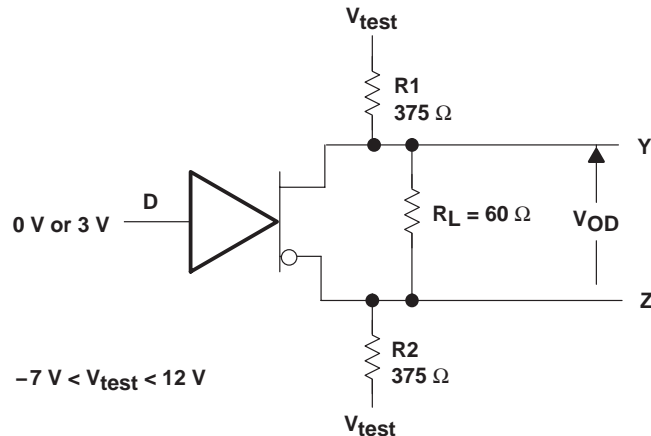
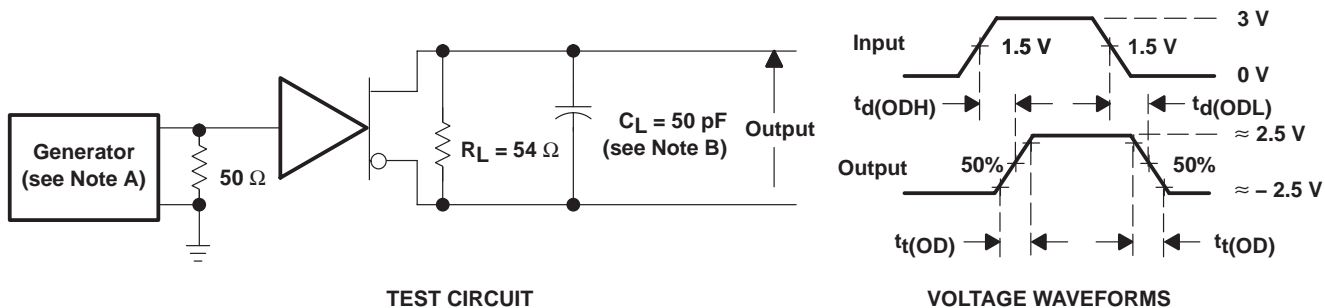
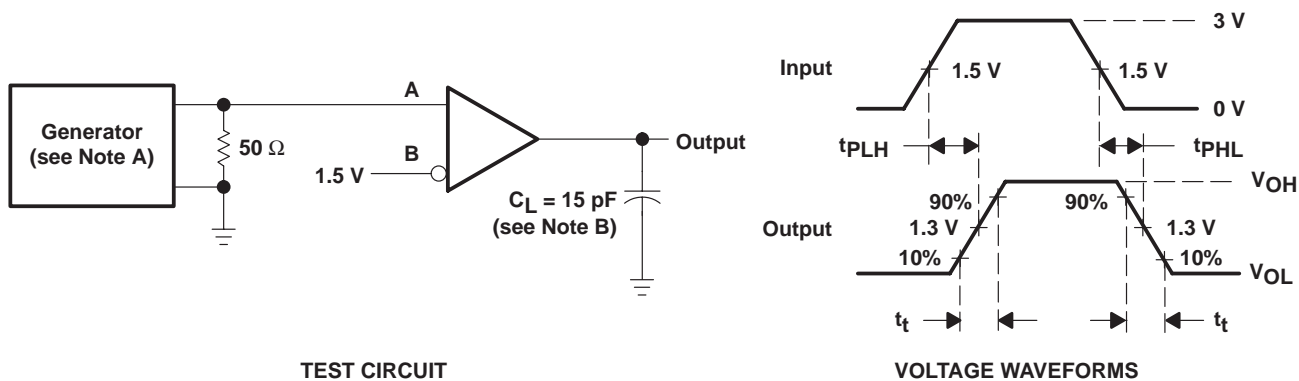

Figure 2. Differential Output Voltage Test Circuit



NOTES: A. The input pulse is supplied by a generator having the following characteristics: PRR ≤ 1 MHz, 50% duty cycle, $t_r \leq 6$ ns, $t_f \leq 6$ ns, $Z_O = 50 \Omega$.
B. C_L includes probe and jig capacitance.

Figure 3. Driver Test Circuits and Differential Output Delay and Transition Time Voltage Waveforms



NOTES: A. The input pulse is supplied by a generator having the following characteristics: PRR ≤ 1 MHz, 50% duty cycle, $t_r \leq 6$ ns, $t_f \leq 6$ ns, $Z_O = 50 \Omega$.
B. C_L includes probe and jig capacitance.

Figure 4. Receiver Test Circuit and Propagation Delay and Transition Time Voltage Waveforms

SN75LBC179, SN65LBC179, SN65LBC179Q LOW-POWER DIFFERENTIAL LINE DRIVER AND RECEIVER PAIRS

SLLS173F – JANUARY 1994 – REVISED APRIL 2006

TYPICAL CHARACTERISTICS

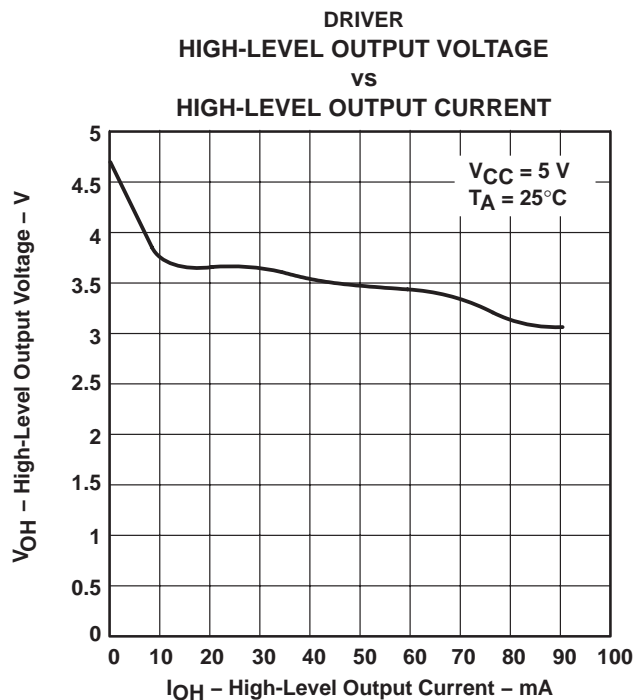

Figure 5

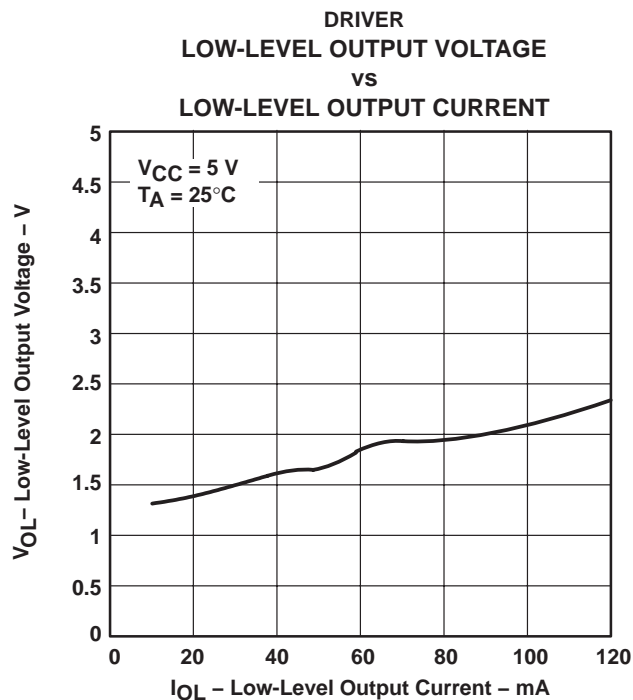

Figure 6

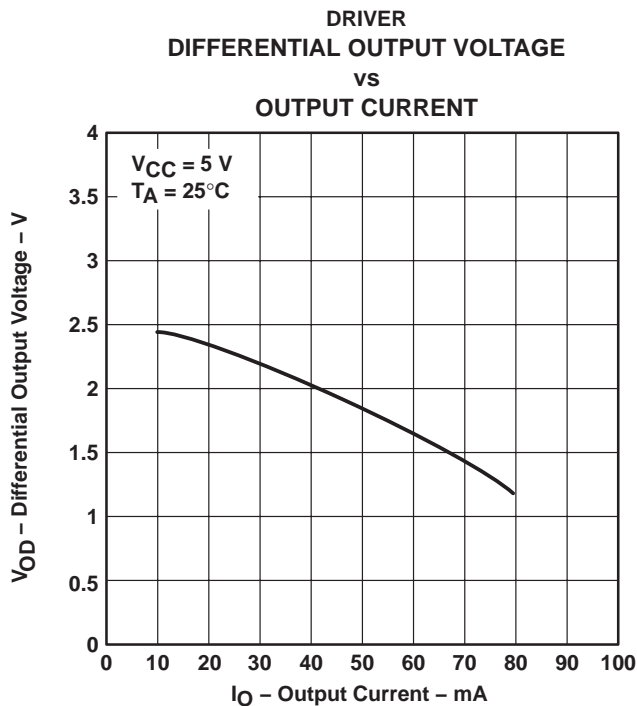

Figure 7

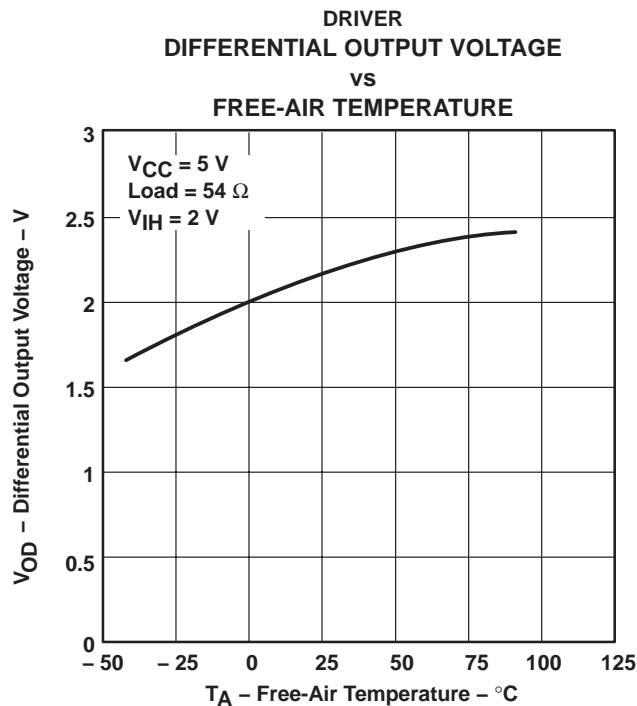

Figure 8



SN75LBC179, SN65LBC179, SN65LBC179Q

LOW-POWER DIFFERENTIAL LINE DRIVER AND RECEIVER PAIRS

SLLS173F – JANUARY 1994 – REVISED APRIL 2006

TYPICAL CHARACTERISTICS

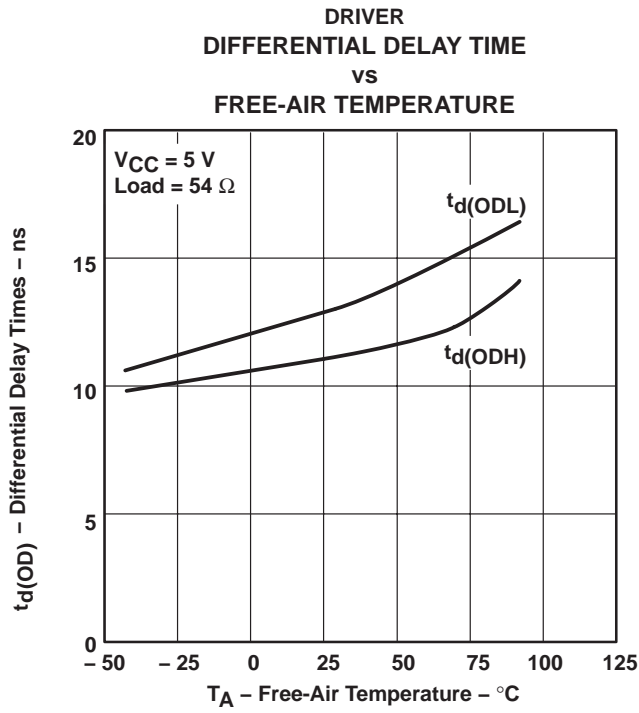

Figure 9

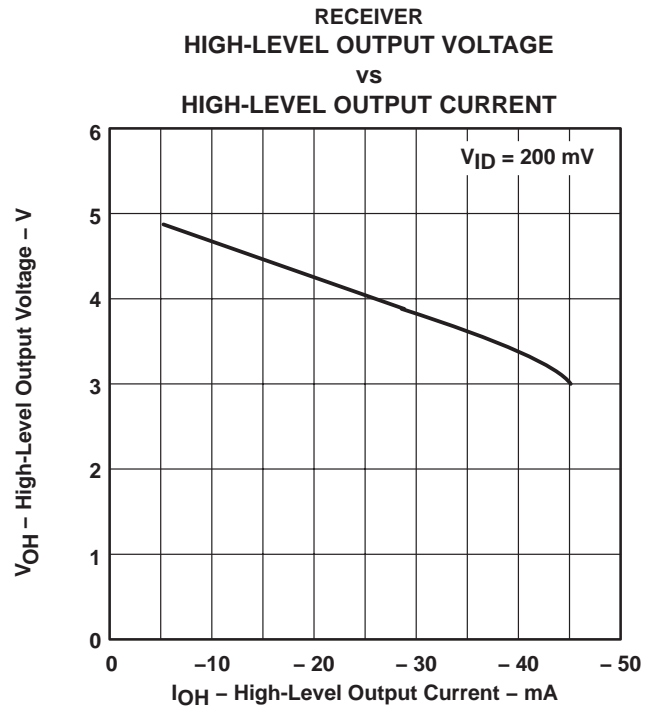

Figure 10

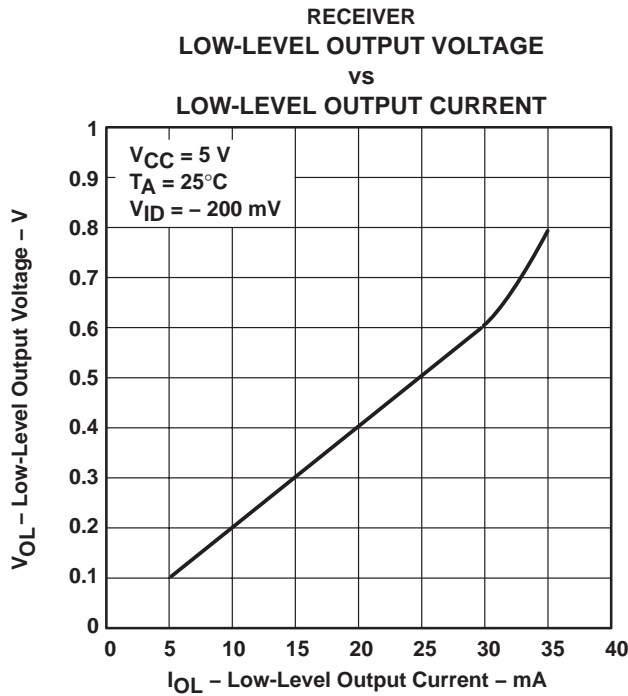

Figure 11

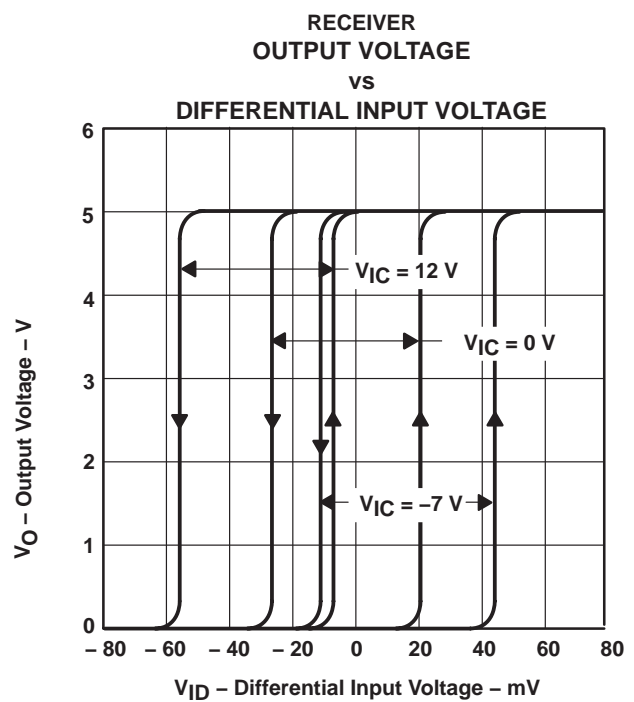
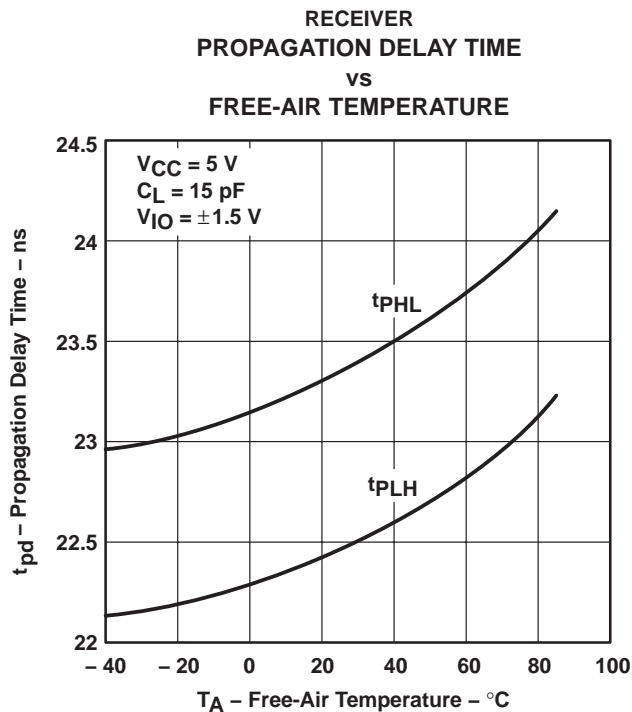
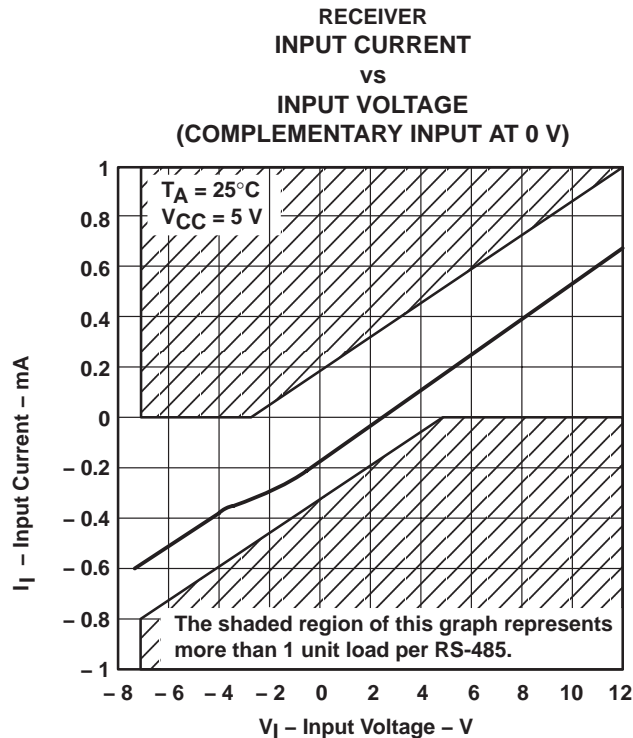
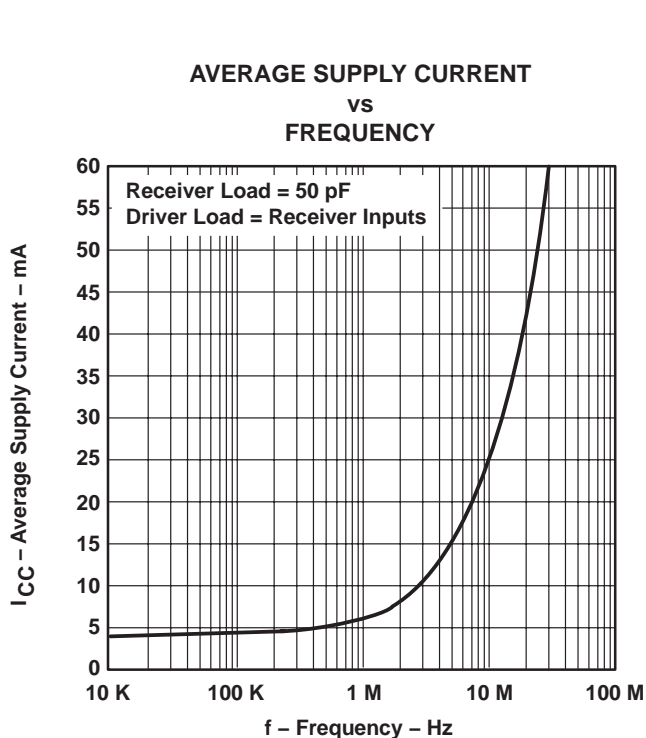

Figure 12

SN75LBC179, SN65LBC179, SN65LBC179Q LOW-POWER DIFFERENTIAL LINE DRIVER AND RECEIVER PAIRS

SLLS173F – JANUARY 1994 – REVISED APRIL 2006

TYPICAL CHARACTERISTICS



SN75LBC179, SN65LBC179, SN65LBC179Q

LOW-POWER DIFFERENTIAL LINE DRIVER AND RECEIVER PAIRS

SLLS173F – JANUARY 1994 – REVISED APRIL 2006

THERMAL CHARACTERISTICS – D PACKAGE

PARAMETER	TEST CONDITIONS	MIN	TYP	MAX	UNIT
Junction-to-ambient thermal resistance, θ_{JA} [†]	Low-K board, no air flow		199.4		°C/W
	High-K board, no air flow		119		
Junction-to-board thermal resistance, θ_{JB}	High-K board, no air flow		67		
Junction-to-case thermal resistance, θ_{JC}			46.6		
Average power dissipation, $P_{(AVG)}$	$R_L = 54 \Omega$, input to D is 10 Mbps 50% duty cycle square wave, $V_{CC} = 5.25 V$, $T_J = 130^\circ C$.			330	mW
Thermal shutdown junction temperature, T_{SD}			165		°C

[†] See TI application note literature number SZZA003, Package Thermal Characterization Methodologies, for an explanation of this parameter.

THERMAL CHARACTERISTICS OF IC PACKAGES

Θ_{JA} (Junction-to-Ambient Thermal Resistance) is defined as the difference in junction temperature to ambient temperature divided by the operating power

Θ_{JA} is NOT a constant and is a strong function of

- the PCB design (50% variation)
- altitude (20% variation)
- device power (5% variation)

Θ_{JA} can be used to compare the thermal performance of packages if the specific test conditions are defined and used. Standardized testing includes specification of PCB construction, test chamber volume, sensor locations, and the thermal characteristics of holding fixtures. Θ_{JA} is often misused when it is used to calculate junction temperatures for other installations.

TI uses two test PCBs as defined by JEDEC specifications. The low-k board gives *average* in-use condition thermal performance and consists of a single trace layer 25 mm long and 2-oz thick copper. The high-k board gives *best case* in-use condition and consists of two 1-oz buried power planes with a single trace layer 25 mm long with 2-oz thick copper. A 4% to 50% difference in Θ_{JA} can be measured between these two test cards

Θ_{JC} (Junction-to-Case Thermal Resistance) is defined as difference in junction temperature to case divided by the operating power. It is measured by putting the mounted package up against a copper block cold plate to force heat to flow from die, through the mold compound into the copper block.

Θ_{JC} is a useful thermal characteristic when a heatsink is applied to package. It is NOT a useful characteristic to predict junction temperature as it provides pessimistic numbers if the case temperature is measured in a non-standard system and junction temperatures are backed out. It can be used with Θ_{JB} in 1-dimensional thermal simulation of a package system.

Θ_{JB} (Junction-to-Board Thermal Resistance) is defined to be the difference in the junction temperature and the PCB temperature at the center of the package (closest to the die) when the PCB is clamped in a cold-plate structure. Θ_{JB} is only defined for the high-k test card.

Θ_{JB} provides an overall thermal resistance between the die and the PCB. It includes a bit of the PCB thermal resistance (especially for BGA's with thermal balls) and can be used for simple 1-dimensional network analysis of package system (see Figure 16).

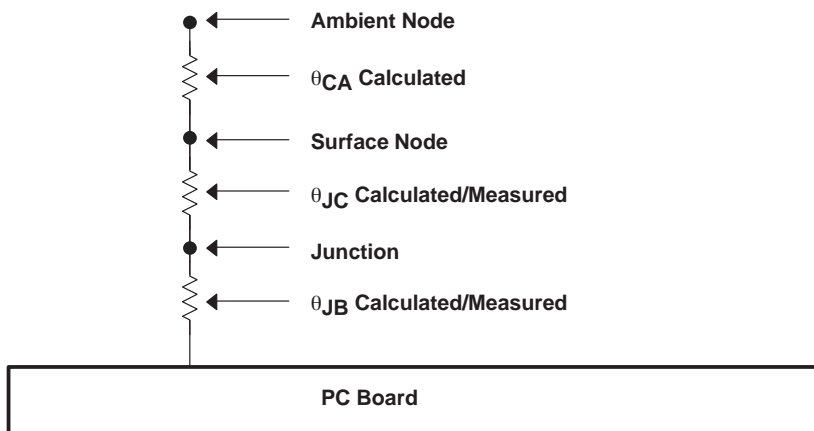

Figure 16. Thermal Resistance

PACKAGING INFORMATION

Orderable Device	Status (1)	Package Type	Package Drawing	Pins	Package Qty	Eco Plan (2)	Lead finish/ Ball material (6)	MSL Peak Temp (3)	Op Temp (°C)	Device Marking (4/5)	Samples
SN65LBC179D	ACTIVE	SOIC	D	8	75	RoHS & Green	NIPDAU	Level-1-260C-UNLIM	-40 to 85	6LB179	Samples
SN65LBC179DR	ACTIVE	SOIC	D	8	2500	RoHS & Green	NIPDAU	Level-1-260C-UNLIM	-40 to 85	6LB179	Samples
SN65LBC179DRG4	ACTIVE	SOIC	D	8	2500	RoHS & Green	NIPDAU	Level-1-260C-UNLIM	-40 to 85	6LB179	Samples
SN65LBC179P	ACTIVE	PDIP	P	8	50	RoHS & Green	NIPDAU	N / A for Pkg Type	-40 to 85	65LBC179	Samples
SN65LBC179QD	ACTIVE	SOIC	D	8	75	RoHS & Green	NIPDAU	Level-1-260C-UNLIM	-40 to 125	LB179Q	Samples
SN65LBC179QDG4	ACTIVE	SOIC	D	8	75	RoHS & Green	NIPDAU	Level-1-260C-UNLIM	-40 to 125	LB179Q	Samples
SN65LBC179QDR	ACTIVE	SOIC	D	8	2500	RoHS & Green	NIPDAU	Level-1-260C-UNLIM	-40 to 125	LB179Q	Samples
SN65LBC179QDRG4	ACTIVE	SOIC	D	8	2500	RoHS & Green	NIPDAU	Level-1-260C-UNLIM	-40 to 125	LB179Q	Samples
SN75LBC179D	ACTIVE	SOIC	D	8	75	RoHS & Green	NIPDAU	Level-1-260C-UNLIM	0 to 70	7LB179	Samples
SN75LBC179DR	ACTIVE	SOIC	D	8	2500	RoHS & Green	NIPDAU	Level-1-260C-UNLIM	0 to 70	7LB179	Samples
SN75LBC179DRG4	ACTIVE	SOIC	D	8	2500	RoHS & Green	NIPDAU	Level-1-260C-UNLIM	0 to 70	7LB179	Samples
SN75LBC179P	ACTIVE	PDIP	P	8	50	RoHS & Green	NIPDAU	N / A for Pkg Type	0 to 70	75LBC179	Samples

(1) The marketing status values are defined as follows:

ACTIVE: Product device recommended for new designs.

LIFEBUY: TI has announced that the device will be discontinued, and a lifetime-buy period is in effect.

NRND: Not recommended for new designs. Device is in production to support existing customers, but TI does not recommend using this part in a new design.

PREVIEW: Device has been announced but is not in production. Samples may or may not be available.

OBSOLETE: TI has discontinued the production of the device.

(2) **RoHS:** TI defines "RoHS" to mean semiconductor products that are compliant with the current EU RoHS requirements for all 10 RoHS substances, including the requirement that RoHS substance do not exceed 0.1% by weight in homogeneous materials. Where designed to be soldered at high temperatures, "RoHS" products are suitable for use in specified lead-free processes. TI may reference these types of products as "Pb-Free".

RoHS Exempt: TI defines "RoHS Exempt" to mean products that contain lead but are compliant with EU RoHS pursuant to a specific EU RoHS exemption.

Green: TI defines "Green" to mean the content of Chlorine (Cl) and Bromine (Br) based flame retardants meet JS709B low halogen requirements of <=1000ppm threshold. Antimony trioxide based flame retardants must also meet the <=1000ppm threshold requirement.

- (3) MSL, Peak Temp. - The Moisture Sensitivity Level rating according to the JEDEC industry standard classifications, and peak solder temperature.
- (4) There may be additional marking, which relates to the logo, the lot trace code information, or the environmental category on the device.
- (5) Multiple Device Markings will be inside parentheses. Only one Device Marking contained in parentheses and separated by a "-" will appear on a device. If a line is indented then it is a continuation of the previous line and the two combined represent the entire Device Marking for that device.
- (6) Lead finish/Ball material - Orderable Devices may have multiple material finish options. Finish options are separated by a vertical ruled line. Lead finish/Ball material values may wrap to two lines if the finish value exceeds the maximum column width.

Important Information and Disclaimer:The information provided on this page represents TI's knowledge and belief as of the date that it is provided. TI bases its knowledge and belief on information provided by third parties, and makes no representation or warranty as to the accuracy of such information. Efforts are underway to better integrate information from third parties. TI has taken and continues to take reasonable steps to provide representative and accurate information but may not have conducted destructive testing or chemical analysis on incoming materials and chemicals. TI and TI suppliers consider certain information to be proprietary, and thus CAS numbers and other limited information may not be available for release.

In no event shall TI's liability arising out of such information exceed the total purchase price of the TI part(s) at issue in this document sold by TI to Customer on an annual basis.

TAPE AND REEL INFORMATION

QUADRANT ASSIGNMENTS FOR PIN 1 ORIENTATION IN TAPE



*All dimensions are nominal

Device	Package Type	Package Drawing	Pins	SPQ	Reel Diameter (mm)	Reel Width W1 (mm)	A0 (mm)	B0 (mm)	K0 (mm)	P1 (mm)	W (mm)	Pin1 Quadrant
SN65LBC179DR	SOIC	D	8	2500	330.0	12.4	6.4	5.2	2.1	8.0	12.0	Q1
SN65LBC179QDR	SOIC	D	8	2500	330.0	12.5	6.4	5.2	2.1	8.0	12.0	Q1
SN75LBC179DR	SOIC	D	8	2500	330.0	12.4	6.4	5.2	2.1	8.0	12.0	Q1

TAPE AND REEL BOX DIMENSIONS

*All dimensions are nominal

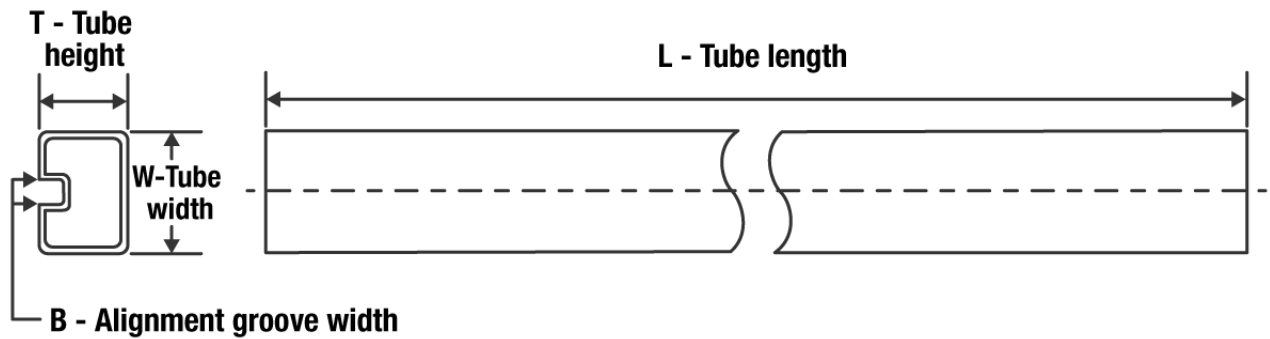
Device	Package Type	Package Drawing	Pins	SPQ	Length (mm)	Width (mm)	Height (mm)
SN65LBC179DR	SOIC	D	8	2500	340.5	336.1	25.0
SN65LBC179QDR	SOIC	D	8	2500	340.5	336.1	25.0
SN75LBC179DR	SOIC	D	8	2500	340.5	336.1	25.0

TUBE

*All dimensions are nominal

Device	Package Name	Package Type	Pins	SPQ	L (mm)	W (mm)	T (μm)	B (mm)
SN65LBC179D	D	SOIC	8	75	507	8	3940	4.32
SN65LBC179P	P	PDIP	8	50	506	13.97	11230	4.32
SN65LBC179QD	D	SOIC	8	75	507	8	3940	4.32
SN65LBC179QDG4	D	SOIC	8	75	507	8	3940	4.32
SN75LBC179D	D	SOIC	8	75	507	8	3940	4.32
SN75LBC179P	P	PDIP	8	50	506	13.97	11230	4.32



D0008A

PACKAGE OUTLINE

SOIC - 1.75 mm max height

SMALL OUTLINE INTEGRATED CIRCUIT



4214825/C 02/2019

NOTES:

- Linear dimensions are in inches [millimeters]. Dimensions in parenthesis are for reference only. Controlling dimensions are in inches. Dimensioning and tolerancing per ASME Y14.5M.
- This drawing is subject to change without notice.
- This dimension does not include mold flash, protrusions, or gate burrs. Mold flash, protrusions, or gate burrs shall not exceed $.006$ [0.15] per side.
- This dimension does not include interlead flash.
- Reference JEDEC registration MS-012, variation AA.

EXAMPLE BOARD LAYOUT

D0008A

SOIC - 1.75 mm max height

SMALL OUTLINE INTEGRATED CIRCUIT



LAND PATTERN EXAMPLE
 EXPOSED METAL SHOWN
 SCALE:8X



SOLDER MASK DETAILS

4214825/C 02/2019

NOTES: (continued)

- 6. Publication IPC-7351 may have alternate designs.
- 7. Solder mask tolerances between and around signal pads can vary based on board fabrication site.

EXAMPLE STENCIL DESIGN

D0008A

SOIC - 1.75 mm max height

SMALL OUTLINE INTEGRATED CIRCUIT

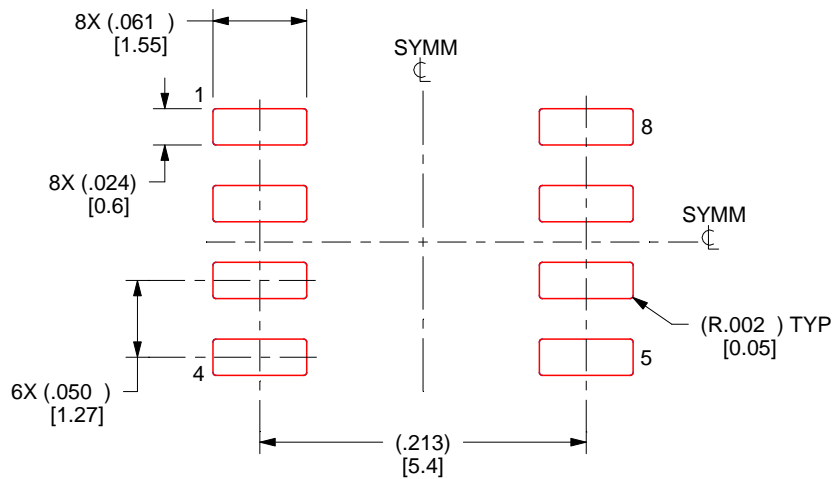

SOLDER PASTE EXAMPLE
BASED ON .005 INCH [0.125 MM] THICK STENCIL
SCALE:8X

4214825/C 02/2019

NOTES: (continued)

8. Laser cutting apertures with trapezoidal walls and rounded corners may offer better paste release. IPC-7525 may have alternate design recommendations.
9. Board assembly site may have different recommendations for stencil design.

P (R-PDIP-T8)

PLASTIC DUAL-IN-LINE PACKAGE

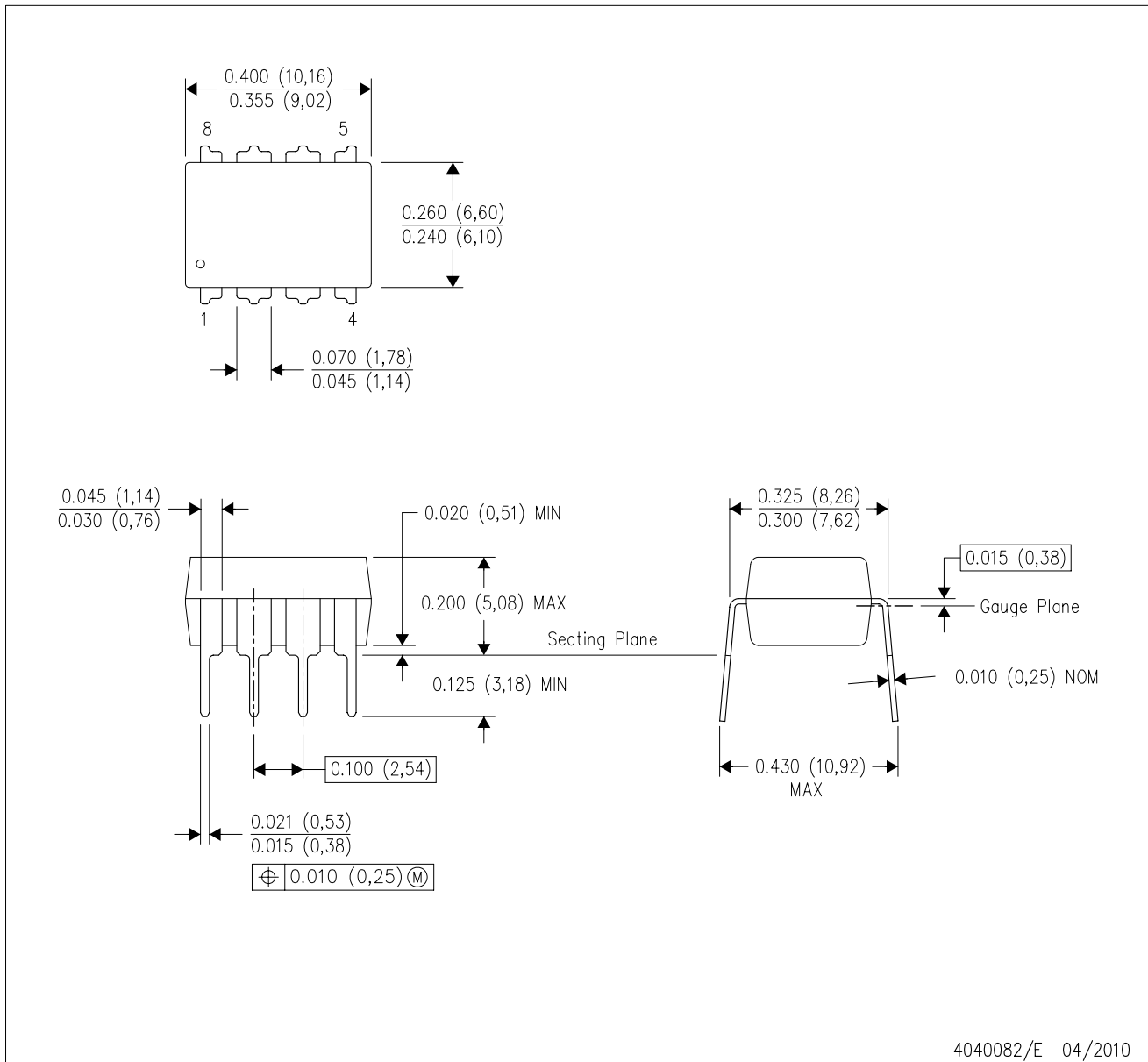

- NOTES:
- A. All linear dimensions are in inches (millimeters).
 - B. This drawing is subject to change without notice.
 - C. Falls within JEDEC MS-001 variation BA.

IMPORTANT NOTICE AND DISCLAIMER

TI PROVIDES TECHNICAL AND RELIABILITY DATA (INCLUDING DATA SHEETS), DESIGN RESOURCES (INCLUDING REFERENCE DESIGNS), APPLICATION OR OTHER DESIGN ADVICE, WEB TOOLS, SAFETY INFORMATION, AND OTHER RESOURCES "AS IS" AND WITH ALL FAULTS, AND DISCLAIMS ALL WARRANTIES, EXPRESS AND IMPLIED, INCLUDING WITHOUT LIMITATION ANY IMPLIED WARRANTIES OF MERCHANTABILITY, FITNESS FOR A PARTICULAR PURPOSE OR NON-INFRINGEMENT OF THIRD PARTY INTELLECTUAL PROPERTY RIGHTS.

These resources are intended for skilled developers designing with TI products. You are solely responsible for (1) selecting the appropriate TI products for your application, (2) designing, validating and testing your application, and (3) ensuring your application meets applicable standards, and any other safety, security, regulatory or other requirements.

These resources are subject to change without notice. TI grants you permission to use these resources only for development of an application that uses the TI products described in the resource. Other reproduction and display of these resources is prohibited. No license is granted to any other TI intellectual property right or to any third party intellectual property right. TI disclaims responsibility for, and you will fully indemnify TI and its representatives against, any claims, damages, costs, losses, and liabilities arising out of your use of these resources.

TI's products are provided subject to [TI's Terms of Sale](#) or other applicable terms available either on ti.com or provided in conjunction with such TI products. TI's provision of these resources does not expand or otherwise alter TI's applicable warranties or warranty disclaimers for TI products.

TI objects to and rejects any additional or different terms you may have proposed.

Mailing Address: Texas Instruments, Post Office Box 655303, Dallas, Texas 75265
Copyright © 2022, Texas Instruments Incorporated