

具有施密特触发输入、三态输出和直通引脚排列的 SN74HCS574-Q1 汽车类八路 D 型触发器

1 特性

- 符合面向汽车应用的 AEC-Q100 标准：
 - 器件温度等级 1：
 - 40°C 至 +125°C, T_A
 - 器件 HBM ESD 分类等级 2
 - 器件 CDM ESD 分类等级 C6
- 采用具有可润湿侧翼的 QFN (WRKS) 封装
- 宽工作电压范围：2V 至 6V
- 施密特触发输入可耐受慢速或高噪声输入信号
- 低功耗
 - I_{CC} 典型值为 100nA
 - 输入泄漏电流典型值为 ±100nA
- 电压为 6V 时，输出驱动为 ±7.8mA

2 应用

- 并行数据同步
- 并行数据存储
- 移位寄存器
- 图形发生器

3 说明

SN74HCS574-Q1 包含八路 D 型触发器。所有输入均包括施密特触发架构。所有通道共享上升沿触发时钟 (CLK) 输入和低电平有效输出使能 (\overline{OE}) 输入。此器件具有直通引脚排列，便于进行总线布线。

器件信息

| 器件型号 | 封装 ⁽¹⁾ | 封装尺寸 (标称值) |
|-------------------|-------------------|-----------------|
| SN74HCS574PW-Q1 | TSSOP (20) | 6.50mm × 4.40mm |
| SN74HCS574WRKS-Q1 | VQFN (20) | 4.50mm × 2.50mm |

(1) 如需了解所有可用封装，请参阅数据表末尾的可订购产品附录

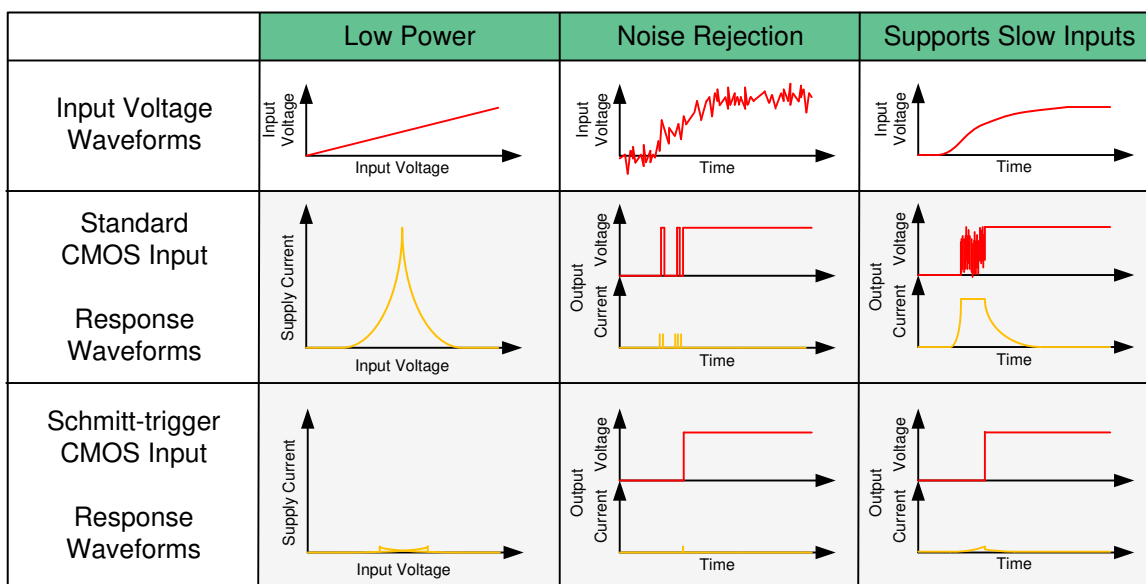

施密特触发输入的优势



Table of Contents

| | | | |
|--|---|--|----|
| 1 特性 | 1 | 8.3 Feature Description..... | 9 |
| 2 应用 | 1 | 8.4 Device Functional Modes..... | 11 |
| 3 说明 | 1 | 9 Application and Implementation | 12 |
| 4 Revision History | 2 | 9.1 Application Information..... | 12 |
| 5 Pin Configuration and Functions | 3 | 9.2 Typical Application..... | 12 |
| 6 Specifications | 4 | 10 Power Supply Recommendations | 15 |
| 6.1 Absolute Maximum Ratings..... | 4 | 11 Layout | 15 |
| 6.2 ESD Ratings..... | 4 | 11.1 Layout Guidelines..... | 15 |
| 6.3 Recommended Operating Conditions..... | 4 | 11.2 Layout Example..... | 15 |
| 6.4 Thermal Information..... | 4 | 12 Device and Documentation Support | 16 |
| 6.5 Electrical Characteristics..... | 5 | 12.1 Documentation Support..... | 16 |
| 6.6 Timing Characteristics..... | 5 | 12.2 接收文档更新通知..... | 16 |
| 6.7 Switching Characteristics..... | 5 | 12.3 支持资源..... | 16 |
| 6.8 Operating Characteristics..... | 6 | 12.4 Trademarks..... | 16 |
| 6.9 Typical Characteristics..... | 7 | 12.5 静电放电警告..... | 16 |
| 7 Parameter Measurement Information | 8 | 12.6 术语表..... | 16 |
| 8 Detailed Description | 9 | 13 Mechanical, Packaging, and Orderable Information | 17 |
| 8.1 Overview..... | 9 | | |
| 8.2 Functional Block Diagram..... | 9 | | |

4 Revision History

注：以前版本的页码可能与当前版本的页码不同

| Changes from Revision * (November 2021) to Revision A (February 2022) | Page |
|--|-------------|
| • 将数据表从“预告信息”更改为“量产数据” | 1 |

5 Pin Configuration and Functions

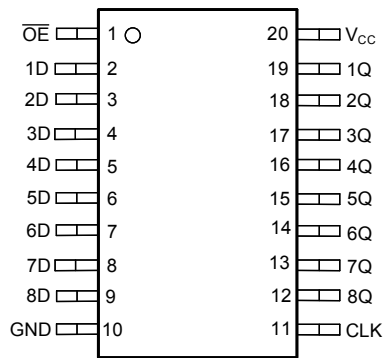

PW Package
20-Pin TSSOP
Top View

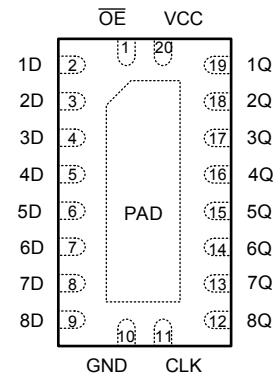

WRKS package
20-Pin VQFN
Top View

Pin Functions

| PIN | | I/O | DESCRIPTION |
|----------------------------|-----|--------|---|
| NAME | NO. | | |
| OE | 1 | Input | Output enable for all channels, active low |
| 1D | 2 | Input | Input for channel 1 |
| 2D | 3 | Input | Input for channel 2 |
| 3D | 4 | Input | Input for channel 3 |
| 4D | 5 | Input | Input for channel 4 |
| 5D | 6 | Input | Input for channel 5 |
| 6D | 7 | Input | Input for channel 6 |
| 7D | 8 | Input | Input for channel 7 |
| 8D | 9 | Input | Input for channel 8 |
| GND | 10 | — | Ground |
| CLK | 11 | Input | Clock input for all channels, rising edge triggered |
| 8Q | 12 | Output | Output for channel 8 |
| 7Q | 13 | Output | Output for channel 7 |
| 6Q | 14 | Output | Output for channel 6 |
| 5Q | 15 | Output | Output for channel 5 |
| 4Q | 16 | Output | Output for channel 4 |
| 3Q | 17 | Output | Output for channel 3 |
| 2Q | 18 | Output | Output for channel 2 |
| 1Q | 19 | Output | Output for channel 1 |
| V _{CC} | 20 | — | Positive supply |
| Thermal Pad ⁽¹⁾ | | — | The thermal pad can be connect to GND or left floating. Do not connect to any other signal or supply. |

(1) WRKS package only.

6 Specifications

6.1 Absolute Maximum Ratings

over operating free-air temperature range (unless otherwise noted)⁽¹⁾

| | | MIN | MAX | UNIT |
|------------------|---|---|-----|--------|
| V _{CC} | Supply voltage | - 0.5 | 7 | V |
| I _{IK} | Input clamp current ⁽²⁾ | V _I < -0.5 V or V _I > V _{CC} + 0.5 V | | ±20 mA |
| I _{OK} | Output clamp current ⁽²⁾ | V _O < -0.5 V or V _O > V _{CC} + 0.5 V | | ±20 mA |
| I _O | Continuous output current | V _O = 0 to V _{CC} | | ±35 mA |
| I _{CC} | Continuous current through V _{CC} or GND | | | ±70 mA |
| T _J | Junction temperature | | | 150 °C |
| T _{stg} | Storage temperature | - 65 | 150 | °C |

- (1) Operation outside the *Absolute Maximum Ratings* may cause permanent device damage. Absolute maximum ratings do not imply functional operation of the device at these or any other conditions beyond those listed under *Recommended Operating Conditions*. If briefly operating outside the *Recommended Operating Conditions* but within the *Absolute Maximum Ratings*, the device may not sustain damage, but it may not be fully functional. Operating the device in this manner may affect device reliability, functionality, performance, and shorten the device lifetime.
- (2) The input and output voltage ratings may be exceeded if the input and output current ratings are observed.

6.2 ESD Ratings

| | | | VALUE | UNIT |
|--------------------|-------------------------|---|-------|------|
| V _(ESD) | Electrostatic discharge | Human body model (HBM), per AEC Q100-002 ⁽¹⁾ HBM ESD Classification Level 2 | ±4000 | V |
| | | Charged device model (CDM), per AEC Q100-011 CDM ESD Classification Level C4B | ±1500 | |

- (1) AEC Q100-002 indicate that HBM stressing shall be in accordance with the ANSI/ESDA/JEDEC JS-001 specification.

6.3 Recommended Operating Conditions

over operating free-air temperature range (unless otherwise noted)

| | | MIN | NOM | MAX | UNIT |
|-----------------|---------------------|------|-----|-----------------|------|
| V _{CC} | Supply voltage | 2 | | 6 | V |
| V _I | Input voltage | 0 | | V _{CC} | V |
| V _O | Output voltage | 0 | | V _{CC} | V |
| T _A | Ambient temperature | - 40 | | 125 | °C |

6.4 Thermal Information

| THERMAL METRIC ⁽¹⁾ | | SN74HCS574-Q1 | | UNIT |
|-------------------------------|--|---------------|-------------|------|
| | | PW (TSSOP) | WRKS (VQFN) | |
| | | 20 PINS | 20 PINS | |
| R _{θJA} | Junction-to-ambient thermal resistance | 151.7 | 83.2 | °C/W |
| R _{θJC(top)} | Junction-to-case (top) thermal resistance | 79.4 | 82.6 | °C/W |
| R _{θJB} | Junction-to-board thermal resistance | 94.7 | 57.4 | °C/W |
| Ψ _{JT} | Junction-to-top characterization parameter | 25.2 | 14.5 | °C/W |
| Ψ _{JB} | Junction-to-board characterization parameter | 94.1 | 56.4 | °C/W |
| R _{θJC(bot)} | Junction-to-case (bottom) thermal resistance | N/A | 40.0 | °C/W |

- (1) For more information about traditional and new thermal metrics, see the [Semiconductor and IC Package Thermal Metrics](#) application report.

6.5 Electrical Characteristics

over operating free-air temperature range; typical values measured at $T_A = 25^\circ\text{C}$ (unless otherwise noted).

| PARAMETER | | TEST CONDITIONS | | V_{CC} | MIN | TYP | MAX | UNIT |
|--------------|----------------------------------|--------------------------------|----------------------------|------------|----------------|------------------|------------|---------------|
| V_{T+} | Positive switching threshold | | | 2 V | 0.7 | | 1.5 | V |
| | | | | 4.5 V | 1.7 | | 3.15 | |
| | | | | 6 V | 2.1 | | 4.2 | |
| V_{T-} | Negative switching threshold | | | 2 V | 0.3 | | 1 | V |
| | | | | 4.5 V | 0.9 | | 2.2 | |
| | | | | 6 V | 1.2 | | 3 | |
| ΔV_T | Hysteresis ($V_{T+} - V_{T-}$) | | | 2 V | 0.2 | | 1 | V |
| | | | | 4.5 V | 0.4 | | 1.4 | |
| | | | | 6 V | 0.6 | | 1.6 | |
| V_{OH} | High-level output voltage | $V_I = V_{IH}$ or V_{IL} | $I_{OH} = -20 \mu\text{A}$ | 2 V to 6 V | $V_{CC} - 0.1$ | $V_{CC} - 0.002$ | | V |
| | | | $I_{OH} = -6 \text{ mA}$ | 4.5 V | 4 | 4.3 | | |
| | | | $I_{OH} = -7.8 \text{ mA}$ | 6 V | 5.4 | 5.75 | | |
| V_{OL} | Low-level output voltage | $V_I = V_{IH}$ or V_{IL} | $I_{OL} = 20 \mu\text{A}$ | 2 V to 6 V | | 0.002 | 0.1 | V |
| | | | $I_{OL} = 6 \text{ mA}$ | 4.5 V | | 0.18 | 0.3 | |
| | | | $I_{OL} = 7.8 \text{ mA}$ | 6 V | | 0.22 | 0.33 | |
| I_I | Input leakage current | $V_I = V_{CC}$ or 0 | | 6 V | | ± 100 | ± 1000 | nA |
| I_{CC} | Supply current | $V_I = V_{CC}$ or 0, $I_O = 0$ | | 6 V | | 0.1 | 2 | μA |
| C_i | Input capacitance | | | 2 V to 6 V | | | 5 | pF |

6.6 Timing Characteristics

over operating free-air temperature range (unless otherwise noted), $C_L = 50 \text{ pF}$

| PARAMETER | | CONDITION | V_{CC} | MIN | MAX | UNIT | |
|--------------------|--------------------------------------|----------------------------|----------|-------|-----|------|-----|
| f_{clock} | Clock Frequency | | | 2 V | | 49 | MHz |
| | | | | 4.5 V | | 120 | |
| | | | | 6 V | | 135 | |
| t_w | Pulse duration | CLK high or low | 2 V | 12 | | ns | |
| | | | 4.5 V | 6 | | | |
| | | | 6 V | 6 | | | |
| t_{su} | Setup time | Data before CLK \uparrow | 2 V | 18 | | ns | |
| | | | 4.5 V | 6 | | | |
| | | | 6 V | 6 | | | |
| t_h | Hold time, data after CLK \uparrow | | | 2 V | 0 | ns | |
| | | | | 4.5 V | 0 | | |
| | | | | 6 V | 0 | | |

6.7 Switching Characteristics

over operating free-air temperature range; typical values measured at $T_A = 25^\circ\text{C}$ (unless otherwise noted). See *Parameter Measurement Information*. $C_L = 50 \text{ pF}$.

| PARAMETER | FROM (INPUT) | TO (OUTPUT) | V_{CC} | MIN | TYP | MAX | UNIT |
|------------------|-------------------------|-------------|----------|-------|-----|-----|------|
| f_{max} | Max switching frequency | | | 2 V | 49 | | MHz |
| | | | | 4.5 V | 120 | | |
| | | | | 6 V | 135 | | |

SN74HCS574-Q1

ZHCSPD0A - NOVEMBER 2021 - REVISED FEBRUARY 2022

over operating free-air temperature range; typical values measured at $T_A = 25^\circ\text{C}$ (unless otherwise noted). See *Parameter Measurement Information*. $C_L = 50\text{ pF}$.

| PARAMETER | | FROM (INPUT) | TO (OUTPUT) | V_{CC} | MIN | TYP | MAX | UNIT |
|-----------|-------------------|-----------------|-------------|----------|-----|-------|------|------|
| t_{pd} | Propogation delay | CLK | Any Q | 2 V | | 26 | 40 | ns |
| | | | | 4.5 V | | 12.2 | 14 | |
| | | | | 6 V | | 10.3 | 11 | |
| t_{en} | Enable time | \overline{OE} | Any Q | 2 V | | 22.16 | 28.8 | ns |
| | | | | 4.5 V | | 10.94 | 14.2 | |
| | | | | 6 V | | 9.23 | 12.0 | |
| t_{dis} | Disable time | \overline{OE} | Any Q | 2 V | | 11.08 | 14.4 | ns |
| | | | | 4.5 V | | 7.65 | 9.9 | |
| | | | | 6 V | | 7.01 | 9.1 | |
| t_t | Transition-time | | Any Q | 2 V | | 14.6 | 19.4 | ns |
| | | | | 4.5 V | | 7.7 | 9.6 | |
| | | | | 6 V | | 7.4 | 10.4 | |

6.8 Operating Characteristics

over operating free-air temperature range; typical values measured at $T_A = 25^\circ\text{C}$ (unless otherwise noted).

| PARAMETER | | TEST CONDITIONS | MIN | TYP | MAX | UNIT |
|-----------|--|-----------------|-----|-----|-----|------|
| C_{pd} | Power dissipation capacitance per gate | No load | | 20 | | pF |

6.9 Typical Characteristics

$T_A = 25^\circ\text{C}$



图 6-1. Output Driver Resistance in LOW State



图 6-2. Output Driver Resistance in HIGH State

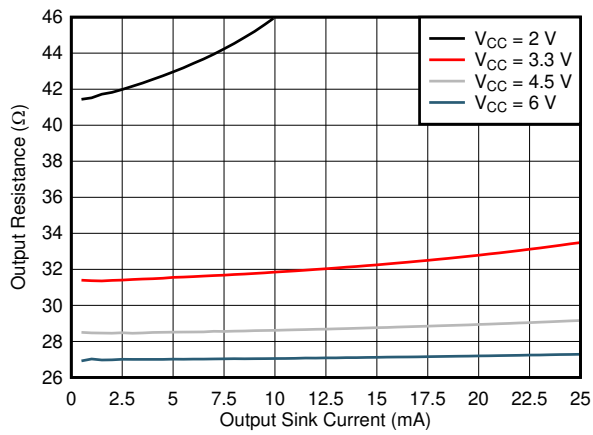

图 6-3. Supply Current Across Input Voltage, 2-, 2.5-, and 3.3-V Supply

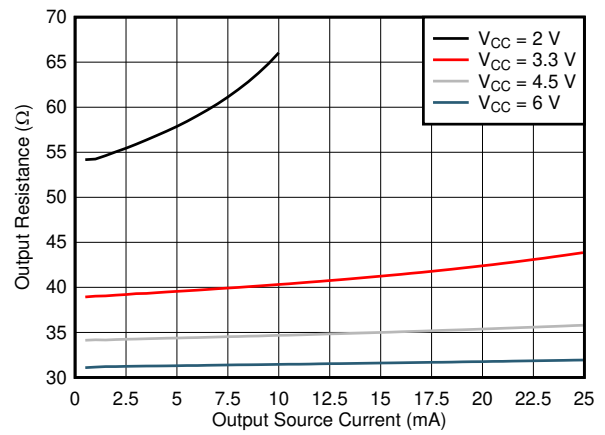

图 6-4. Supply Current Across Input Voltage, 4.5-, 5-, and 6-V Supply

7 Parameter Measurement Information

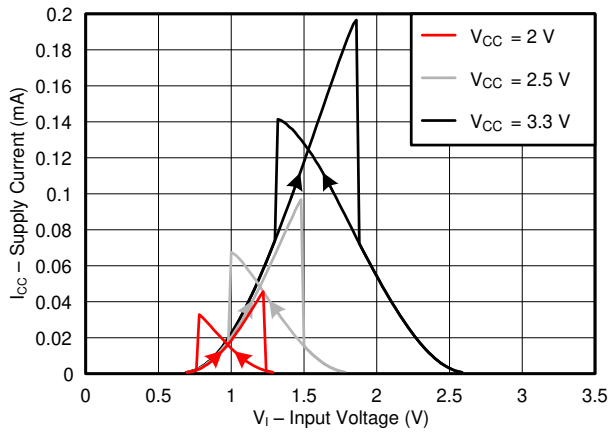
Phase relationships between waveforms were chosen arbitrarily. All input pulses are supplied by generators having the following characteristics: $PRR \leq 1 \text{ MHz}$, $Z_O = 50 \Omega$, $t_t < 2.5 \text{ ns}$.

For clock inputs, f_{max} is measured when the input duty cycle is 50%.

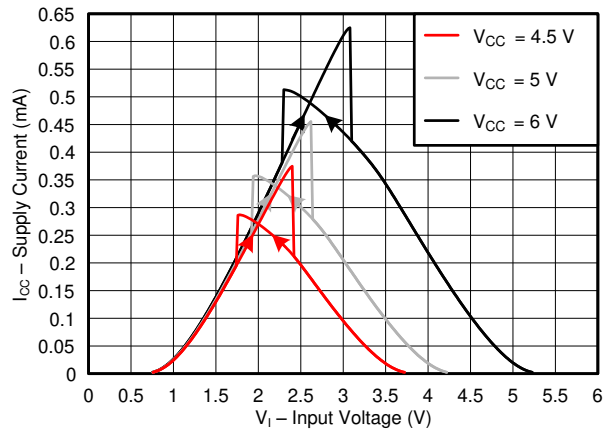
The outputs are measured one at a time with one input transition per measurement.

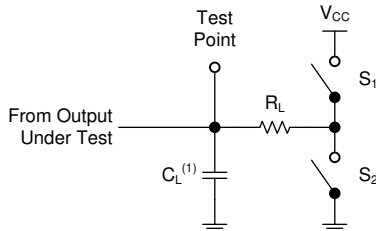

(1) C_L includes probe and test-fixture capacitance.

图 7-1. Load Circuit for 3-State Outputs



图 7-3. Voltage Waveforms, Setup and Hold Times



图 7-2. Voltage Waveforms, Pulse Duration

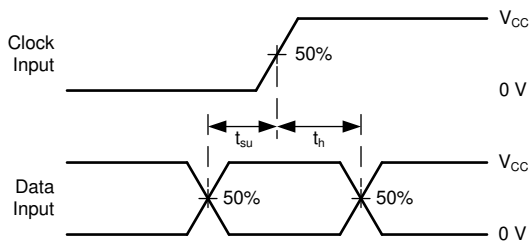

(1) The greater between t_{PLH} and t_{PHL} is the same as t_{pd} .

图 7-4. Voltage Waveforms Propagation Delays

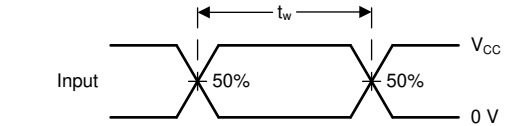
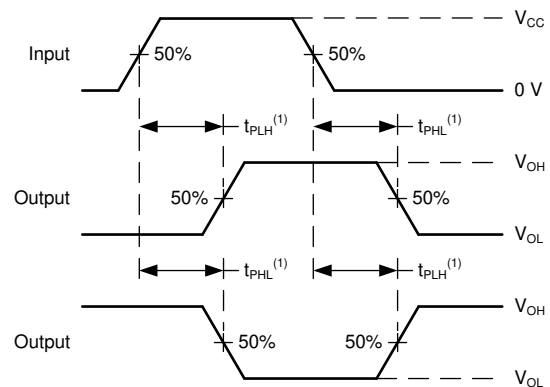

图 7-5. Voltage Waveforms Propagation Delays



(1) The greater between t_r and t_f is the same as t_t .

图 7-6. Voltage Waveforms, Input and Output Transition Times

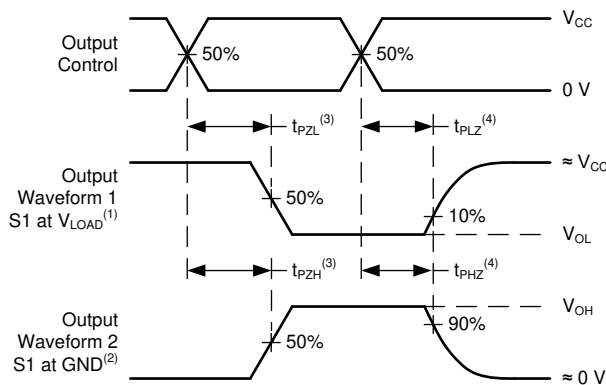
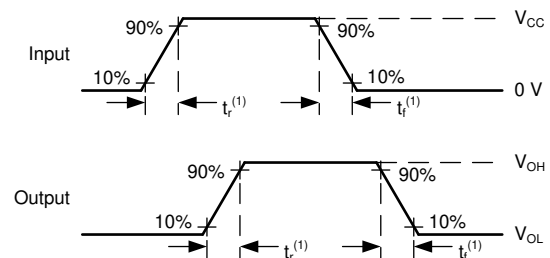
8 Detailed Description

8.1 Overview

The SN74HCS574-Q1 contains eight D-type flip-flops. All inputs include Schmitt-trigger architecture. All channels share a clock (CLK) and output enable (\overline{OE}) input.

Data is stored in the flip-flop on the rising edge of the clock.

The output state of all channels is unknown at startup until valid data is clocked into the flip-flops.

When the outputs are enabled (\overline{OE} is low), the outputs are actively driving low or high.

When the outputs are disabled (\overline{OE} is high), the outputs are set into the high-impedance state.

The active low output enable (\overline{OE}) does not have any impact on the stored state in the flip-flops.

8.2 Functional Block Diagram

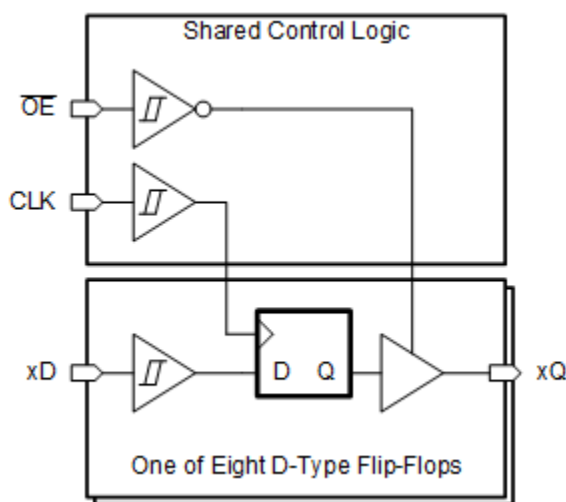

8.3 Feature Description

8.3.1 Balanced CMOS 3-State Outputs

This device includes balanced CMOS 3-State outputs. The three states that these outputs can be in are driving high, driving low, and high impedance. The term "balanced" indicates that the device can sink and source similar currents. The drive capability of this device may create fast edges into light loads so routing and load conditions should be considered to prevent ringing. Additionally, the outputs of this device are capable of driving larger currents than the device can sustain without being damaged. It is important for the output power of the device to be limited to avoid damage due to overcurrent. The electrical and thermal limits defined in the *Absolute Maximum Ratings* must be followed at all times.

When placed into the high-impedance mode, the output will neither source nor sink current, with the exception of minor leakage current as defined in the *Electrical Characteristics* table. In the high-impedance state, the output voltage is not controlled by the device and is dependent on external factors. If no other drivers are connected to the node, then this is known as a floating node and the voltage is unknown. A pull-up or pull-down resistor can be connected to the output to provide a known voltage at the output while it is in the high-impedance state. The value of the resistor will depend on multiple factors, including parasitic capacitance and power consumption limitations. Typically, a 10 k Ω resistor can be used to meet these requirements.

Unused 3-state CMOS outputs should be left disconnected.

8.3.2 CMOS Schmitt-Trigger Inputs

This device includes inputs with the Schmitt-trigger architecture. These inputs are high impedance and are typically modeled as a resistor in parallel with the input capacitance given in the *Electrical Characteristics* table from the input to ground. The worst case resistance is calculated with the maximum input voltage, given in the

Absolute Maximum Ratings table, and the maximum input leakage current, given in the *Electrical Characteristics* table, using Ohm's law ($R = V \div I$).

The Schmitt-trigger input architecture provides hysteresis as defined by ΔV_T in the *Electrical Characteristics* table, which makes this device extremely tolerant to slow or noisy inputs. While the inputs can be driven much slower than standard CMOS inputs, it is still recommended to properly terminate unused inputs. Driving the inputs with slow transitioning signals will increase dynamic current consumption of the device. For additional information regarding Schmitt-trigger inputs, please see [Understanding Schmitt Triggers](#).

8.3.3 Clamp Diode Structure

The inputs and outputs to this device have both positive and negative clamping diodes as depicted in [Electrical Placement of Clamping Diodes for Each Input and Output](#).

CAUTION

Voltages beyond the values specified in the *Absolute Maximum Ratings* table can cause damage to the device. The input and output voltage ratings may be exceeded if the input and output clamp-current ratings are observed.



图 8-1. Electrical Placement of Clamping Diodes for Each Input and Output

8.3.4 Wettable Flanks

This device includes wettable flanks for at least one package. See the *Features* section on the front page of the data sheet for which packages include this feature.

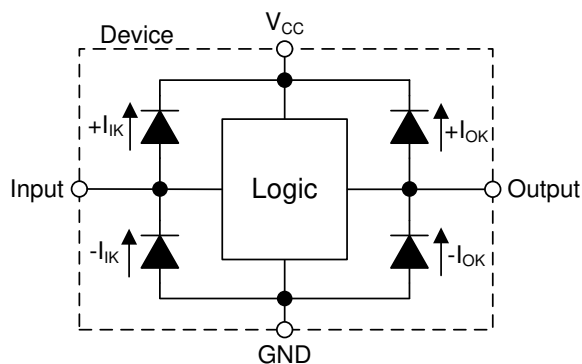

图 8-2. Simplified Cutaway View of Wettable-Flank QFN Package and Standard QFN Package After Soldering

Wettable flanks help improve side wetting after soldering which makes QFN packages easier to inspect with automatic optical inspection (AOI). A wettable flank can be dimpled or step-cut to provide additional surface area for solder adhesion which assists in reliably creating a side fillet as shown in 图 8-2. Please see the mechanical drawing for additional details.

8.4 Device Functional Modes

表 8-1. Function Table

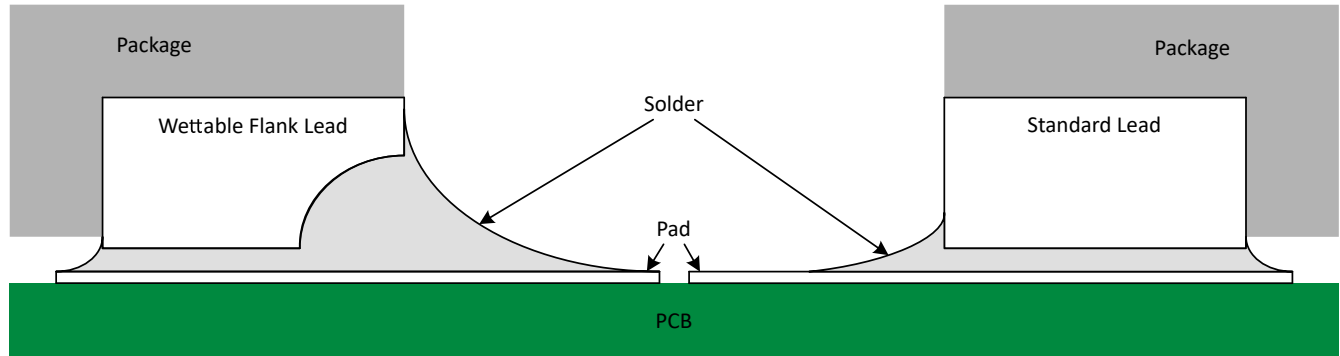
| INPUTS ⁽¹⁾ | | | OUTPUT ⁽²⁾ |
|-----------------------|---------|---|-------------------------------|
| OE | CLK | D | Q |
| L | ↑ | L | L |
| L | ↑ | H | H |
| L | L, H, ↓ | X | Q ₀ ⁽³⁾ |
| H | X | X | Z |

- (1) L = input low, H = input high, ↑ = input transitioning from low to high, ↓ = input transitioning from high to low, X = don't care
- (2) L = output low, H = output high, Q₀ = previous state, Z = high impedance
- (3) At startup, Q₀ is unknown

9 Application and Implementation

备注

Information in the following applications sections is not part of the TI component specification, and TI does not warrant its accuracy or completeness. TI's customers are responsible for determining suitability of components for their purposes, as well as validating and testing their design implementation to confirm system functionality.

9.1 Application Information

In this application, the SN74HCS574-Q1 is used to control an 8-bit data bus.

All outputs change with the rising edge of the CLK input, which can be used to synchronize signals.

The outputs can set to the high-impedance state using the \overline{OE} to allow other devices to transmit on the data bus.

9.2 Typical Application



图 9-1.

9.2.1 Design Requirements

9.2.1.1 Power Considerations

Ensure the desired supply voltage is within the range specified in the *Recommended Operating Conditions*. The supply voltage sets the device's electrical characteristics as described in the *Electrical Characteristics*.

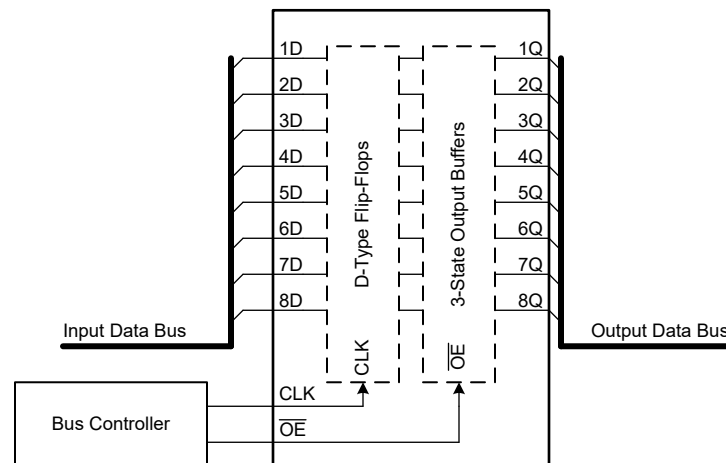
The positive voltage supply must be capable of sourcing current equal to the total current to be sourced by all outputs of the SN74HCS574-Q1 plus the maximum static supply current, I_{CC} , listed in *Electrical Characteristics* and any transient current required for switching. The logic device can only source as much current as is provided by the positive supply source. Be sure not to exceed the maximum total current through V_{CC} listed in the *Absolute Maximum Ratings*.

The ground must be capable of sinking current equal to the total current to be sunk by all outputs of the SN74HCS574-Q1 plus the maximum supply current, I_{CC} , listed in *Electrical Characteristics*, and any transient current required for switching. The logic device can only sink as much current as can be sunk into its ground connection. Be sure not to exceed the maximum total current through GND listed in the *Absolute Maximum Ratings*.

The SN74HCS574-Q1 can drive a load with a total capacitance less than or equal to 50 pF while still meeting all of the datasheet specifications. Larger capacitive loads can be applied, however it is not recommended to exceed 50 pF.

The SN74HCS574-Q1 can drive a load with total resistance described by $R_L \geq V_O / I_O$, with the output voltage and current defined in the *Electrical Characteristics* table with V_{OH} and V_{OL} . When outputting in the high state, the output voltage in the equation is defined as the difference between the measured output voltage and the supply voltage at the V_{CC} pin.

Total power consumption can be calculated using the information provided in [CMOS Power Consumption and Cpd Calculation](#).

Thermal increase can be calculated using the information provided in [Thermal Characteristics of Standard Linear and Logic \(SLL\) Packages and Devices](#).

CAUTION

The maximum junction temperature, $T_{J(max)}$ listed in the *Absolute Maximum Ratings*, is an additional limitation to prevent damage to the device. Do not violate any values listed in the *Absolute Maximum Ratings*. These limits are provided to prevent damage to the device.

9.2.1.2 Input Considerations

Input signals must cross $V_{t-(min)}$ to be considered a logic LOW, and $V_{t+(max)}$ to be considered a logic HIGH. Do not exceed the maximum input voltage range found in the *Absolute Maximum Ratings*.

Unused inputs must be terminated to either V_{CC} or ground. These can be directly terminated if the input is completely unused, or they can be connected with a pull-up or pull-down resistor if the input is to be used sometimes, but not always. A pull-up resistor is used for a default state of HIGH, and a pull-down resistor is used for a default state of LOW. The resistor size is limited by drive current of the controller, leakage current into the SN74HCS574-Q1, as specified in the *Electrical Characteristics*, and the desired input transition rate. A 10-k Ω resistor value is often used due to these factors.

The SN74HCS574-Q1 has no input signal transition rate requirements because it has Schmitt-trigger inputs.

Another benefit to having Schmitt-trigger inputs is the ability to reject noise. Noise with a large enough amplitude can still cause issues. To know how much noise is too much, please refer to the $\Delta V_{T(min)}$ in the *Electrical Characteristics*. This hysteresis value will provide the peak-to-peak limit.

Unlike what happens with standard CMOS inputs, Schmitt-trigger inputs can be held at any valid value without causing huge increases in power consumption. The typical additional current caused by holding an input at a value other than V_{CC} or ground is plotted in the *Typical Characteristics*.

Refer to the *Feature Description* section for additional information regarding the inputs for this device.

9.2.1.3 Output Considerations

The positive supply voltage is used to produce the output HIGH voltage. Drawing current from the output will decrease the output voltage as specified by the V_{OH} specification in the *Electrical Characteristics*. The ground voltage is used to produce the output LOW voltage. Sinking current into the output will increase the output voltage as specified by the V_{OL} specification in the *Electrical Characteristics*.

Push-pull outputs that could be in opposite states, even for a very short time period, should never be connected directly together. This can cause excessive current and damage to the device.

Two channels within the same device with the same input signals can be connected in parallel for additional output drive strength.

Unused outputs can be left floating. Do not connect outputs directly to V_{CC} or ground.

Refer to *Feature Description* section for additional information regarding the outputs for this device.

9.2.2 Detailed Design Procedure

1. Add a decoupling capacitor from V_{CC} to GND. The capacitor needs to be placed physically close to the device and electrically close to both the V_{CC} and GND pins. An example layout is shown in the *Layout* section.

2. Ensure the capacitive load at the output is ≤ 50 pF. This is not a hard limit, however it will ensure optimal performance. This can be accomplished by providing short, appropriately sized traces from the SN74HCS574-Q1 to the receiving device(s).
3. Ensure the resistive load at the output is larger than $(V_{CC} / I_{O(max)}) \Omega$. This will ensure that the maximum output current from the *Absolute Maximum Ratings* is not violated. Most CMOS inputs have a resistive load measured in megaohms; much larger than the minimum calculated above.
4. Thermal issues are rarely a concern for logic gates, however the power consumption and thermal increase can be calculated using the steps provided in the application report, [CMOS Power Consumption and Cpd Calculation](#).

9.2.3 Application Curves



图 9-2. Example timing diagram for one channel

10 Power Supply Recommendations

The power supply can be any voltage between the minimum and maximum supply voltage rating located in the *Recommended Operating Conditions*. Each V_{CC} terminal should have a good bypass capacitor to prevent power disturbance. A 0.1- μ F capacitor is recommended for this device. It is acceptable to parallel multiple bypass caps to reject different frequencies of noise. The 0.1- μ F and 1- μ F capacitors are commonly used in parallel. The bypass capacitor should be installed as close to the power terminal as possible for best results, as shown in given example layout image.

11 Layout

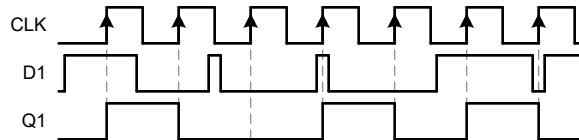
11.1 Layout Guidelines

When using multiple-input and multiple-channel logic devices inputs must not ever be left floating. In many cases, functions or parts of functions of digital logic devices are unused; for example, when only two inputs of a triple-input AND gate are used or only 3 of the 4 buffer gates are used. Such unused input pins must not be left unconnected because the undefined voltages at the outside connections result in undefined operational states. All unused inputs of digital logic devices must be connected to a logic high or logic low voltage, as defined by the input voltage specifications, to prevent them from floating. The logic level that must be applied to any particular unused input depends on the function of the device. Generally, the inputs are tied to GND or V_{CC} , whichever makes more sense for the logic function or is more convenient.

11.2 Layout Example



图 11-1. Example layout for the SN74HCS574-Q1 in the WRKS Package

12 Device and Documentation Support

TI offers an extensive line of development tools. Tools and software to evaluate the performance of the device, generate code, and develop solutions are listed below.

12.1 Documentation Support

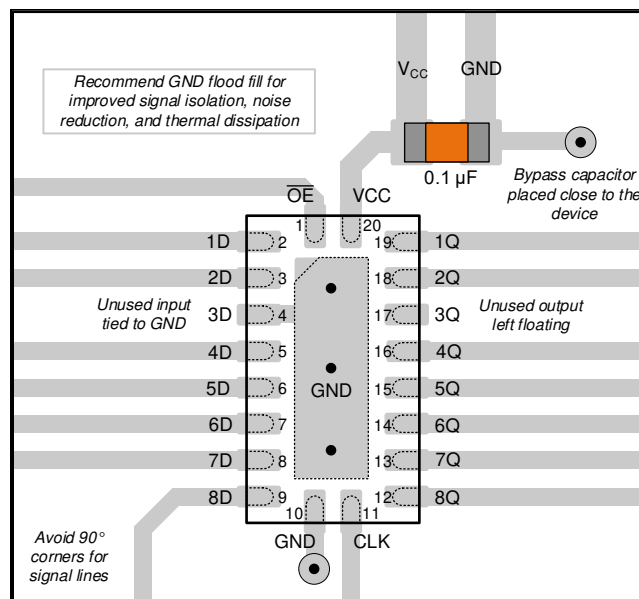
12.1.1 Related Documentation

For related documentation see the following:

- Texas Instruments, [HCMOS Design Considerations application report \(SCLA007\)](#)
- Texas Instruments, [CMOS Power Consumption and \$C_{pd}\$ Calculation application report \(SDYA009\)](#)
- Texas Instruments, [Designing With Logic application report](#)

12.2 接收文档更新通知

要接收文档更新通知，请导航至 ti.com 上的器件产品文件夹。点击 [订阅更新](#) 进行注册，即可每周接收产品信息更改摘要。有关更改的详细信息，请查看任何已修订文档中包含的修订历史记录。

12.3 支持资源

[TI E2E™ 支持论坛](#) 是工程师的重要参考资料，可直接从专家获得快速、经过验证的解答和设计帮助。搜索现有解答或提出自己的问题可获得所需的快速设计帮助。

链接的内容由各个贡献者“按原样”提供。这些内容并不构成 TI 技术规范，并且不一定反映 TI 的观点；请参阅 TI 的 [《使用条款》](#)。

12.4 Trademarks

TI E2E™ is a trademark of Texas Instruments.

所有商标均为其各自所有者的财产。

12.5 静电放电警告



静电放电 (ESD) 会损坏这个集成电路。德州仪器 (TI) 建议通过适当的预防措施处理所有集成电路。如果不遵守正确的处理和安装程序，可能会损坏集成电路。

ESD 的损坏小至导致微小的性能降级，大至整个器件故障。精密的集成电路可能更容易受到损坏，这是因为非常细微的参数更改都可能会导致器件与其发布的规格不相符。

12.6 术语表

[TI 术语表](#) 本术语表列出并解释了术语、首字母缩略词和定义。

13 Mechanical, Packaging, and Orderable Information

The following pages include mechanical, packaging, and orderable information. This information is the most current data available for the designated devices. This data is subject to change without notice and revision of this document. For browser-based versions of this data sheet, refer to the left-hand navigation.

PACKAGING INFORMATION

| Orderable Device | Status (1) | Package Type | Package Drawing | Pins | Package Qty | Eco Plan (2) | Lead finish/ Ball material (6) | MSL Peak Temp (3) | Op Temp (°C) | Device Marking (4/5) | Samples |
|--------------------|---------------|--------------|-----------------|------|-------------|-----------------|--------------------------------------|----------------------|--------------|-------------------------|-------------------------|
| SN74HCS574QPWRQ1 | ACTIVE | TSSOP | PW | 20 | 2000 | RoHS & Green | NIPDAU | Level-1-260C-UNLIM | -40 to 125 | HCS574Q | Samples |
| SN74HCS574QWRKSRQ1 | ACTIVE | VQFN | RKS | 20 | 3000 | RoHS & Green | NIPDAU | Level-1-260C-UNLIM | -40 to 125 | HCS574Q | Samples |

(1) The marketing status values are defined as follows:

ACTIVE: Product device recommended for new designs.

LIFEBUY: TI has announced that the device will be discontinued, and a lifetime-buy period is in effect.

NRND: Not recommended for new designs. Device is in production to support existing customers, but TI does not recommend using this part in a new design.

PREVIEW: Device has been announced but is not in production. Samples may or may not be available.

OBSELETE: TI has discontinued the production of the device.

(2) **RoHS:** TI defines "RoHS" to mean semiconductor products that are compliant with the current EU RoHS requirements for all 10 RoHS substances, including the requirement that RoHS substance do not exceed 0.1% by weight in homogeneous materials. Where designed to be soldered at high temperatures, "RoHS" products are suitable for use in specified lead-free processes. TI may reference these types of products as "Pb-Free".

RoHS Exempt: TI defines "RoHS Exempt" to mean products that contain lead but are compliant with EU RoHS pursuant to a specific EU RoHS exemption.

Green: TI defines "Green" to mean the content of Chlorine (Cl) and Bromine (Br) based flame retardants meet JS709B low halogen requirements of <=1000ppm threshold. Antimony trioxide based flame retardants must also meet the <=1000ppm threshold requirement.

(3) MSL, Peak Temp. - The Moisture Sensitivity Level rating according to the JEDEC industry standard classifications, and peak solder temperature.

(4) There may be additional marking, which relates to the logo, the lot trace code information, or the environmental category on the device.

(5) Multiple Device Markings will be inside parentheses. Only one Device Marking contained in parentheses and separated by a "~" will appear on a device. If a line is indented then it is a continuation of the previous line and the two combined represent the entire Device Marking for that device.

(6) Lead finish/Ball material - Orderable Devices may have multiple material finish options. Finish options are separated by a vertical ruled line. Lead finish/Ball material values may wrap to two lines if the finish value exceeds the maximum column width.

Important Information and Disclaimer:The information provided on this page represents TI's knowledge and belief as of the date that it is provided. TI bases its knowledge and belief on information provided by third parties, and makes no representation or warranty as to the accuracy of such information. Efforts are underway to better integrate information from third parties. TI has taken and continues to take reasonable steps to provide representative and accurate information but may not have conducted destructive testing or chemical analysis on incoming materials and chemicals. TI and TI suppliers consider certain information to be proprietary, and thus CAS numbers and other limited information may not be available for release.

In no event shall TI's liability arising out of such information exceed the total purchase price of the TI part(s) at issue in this document sold by TI to Customer on an annual basis.

OTHER QUALIFIED VERSIONS OF SN74HCS574-Q1 :

- Catalog : [SN74HCS574](#)

NOTE: Qualified Version Definitions:

- Catalog - TI's standard catalog product

TAPE AND REEL INFORMATION

QUADRANT ASSIGNMENTS FOR PIN 1 ORIENTATION IN TAPE

*All dimensions are nominal

| Device | Package Type | Package Drawing | Pins | SPQ | Reel Diameter (mm) | Reel Width W1 (mm) | A0 (mm) | B0 (mm) | K0 (mm) | P1 (mm) | W (mm) | Pin1 Quadrant |
|--------------------|--------------|-----------------|------|------|--------------------|--------------------|---------|---------|---------|---------|--------|---------------|
| SN74HCS574QPWRQ1 | TSSOP | PW | 20 | 2000 | 330.0 | 16.4 | 6.95 | 7.0 | 1.4 | 8.0 | 16.0 | Q1 |
| SN74HCS574QWRKSRQ1 | VQFN | RKS | 20 | 3000 | 180.0 | 12.4 | 2.8 | 4.8 | 1.2 | 4.0 | 12.0 | Q1 |

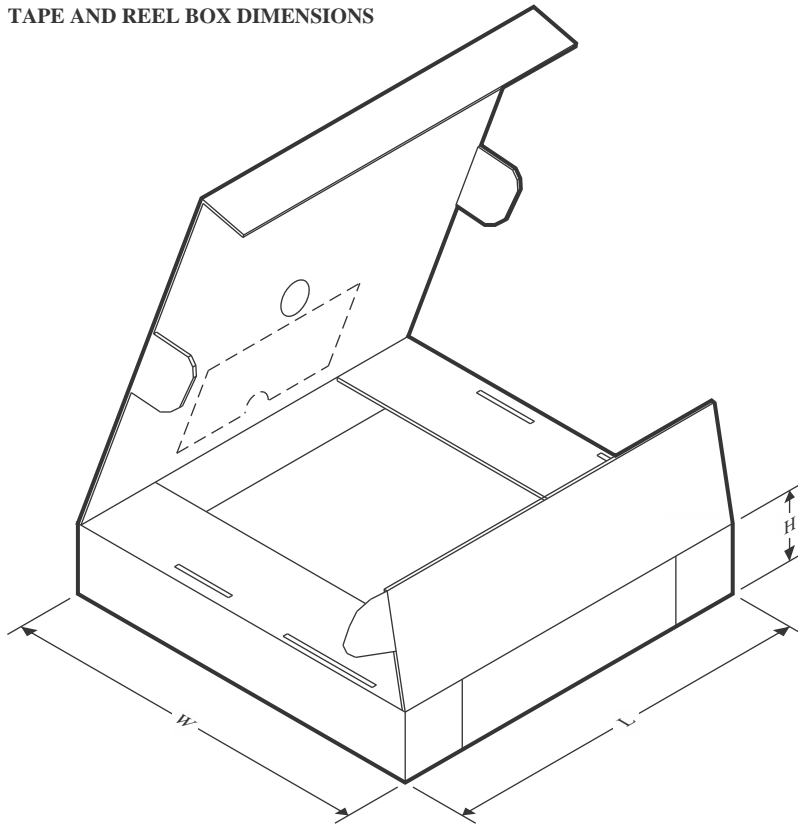
TAPE AND REEL BOX DIMENSIONS

*All dimensions are nominal

| Device | Package Type | Package Drawing | Pins | SPQ | Length (mm) | Width (mm) | Height (mm) |
|--------------------|--------------|-----------------|------|------|-------------|------------|-------------|
| SN74HCS574QPWRQ1 | TSSOP | PW | 20 | 2000 | 356.0 | 356.0 | 35.0 |
| SN74HCS574QWRKSRQ1 | VQFN | RKS | 20 | 3000 | 210.0 | 185.0 | 35.0 |

EXAMPLE BOARD LAYOUT

PW0020A

TSSOP - 1.2 mm max height

SMALL OUTLINE PACKAGE



LAND PATTERN EXAMPLE
EXPOSED METAL SHOWN
SCALE: 10X



SOLDER MASK DETAILS

4220206/A 02/2017

NOTES: (continued)

- 6. Publication IPC-7351 may have alternate designs.
- 7. Solder mask tolerances between and around signal pads can vary based on board fabrication site.

EXAMPLE STENCIL DESIGN

PW0020A

TSSOP - 1.2 mm max height

SMALL OUTLINE PACKAGE



SOLDER PASTE EXAMPLE
BASED ON 0.125 mm THICK STENCIL
SCALE: 10X

4220206/A 02/2017

NOTES: (continued)

8. Laser cutting apertures with trapezoidal walls and rounded corners may offer better paste release. IPC-7525 may have alternate design recommendations.
9. Board assembly site may have different recommendations for stencil design.

GENERIC PACKAGE VIEW

RKS 20

VQFN - 1 mm max height

2.5 x 4.5, 0.5 mm pitch

PLASTIC QUAD FLATPACK - NO LEAD

This image is a representation of the package family, actual package may vary.
Refer to the product data sheet for package details.



4226872/A

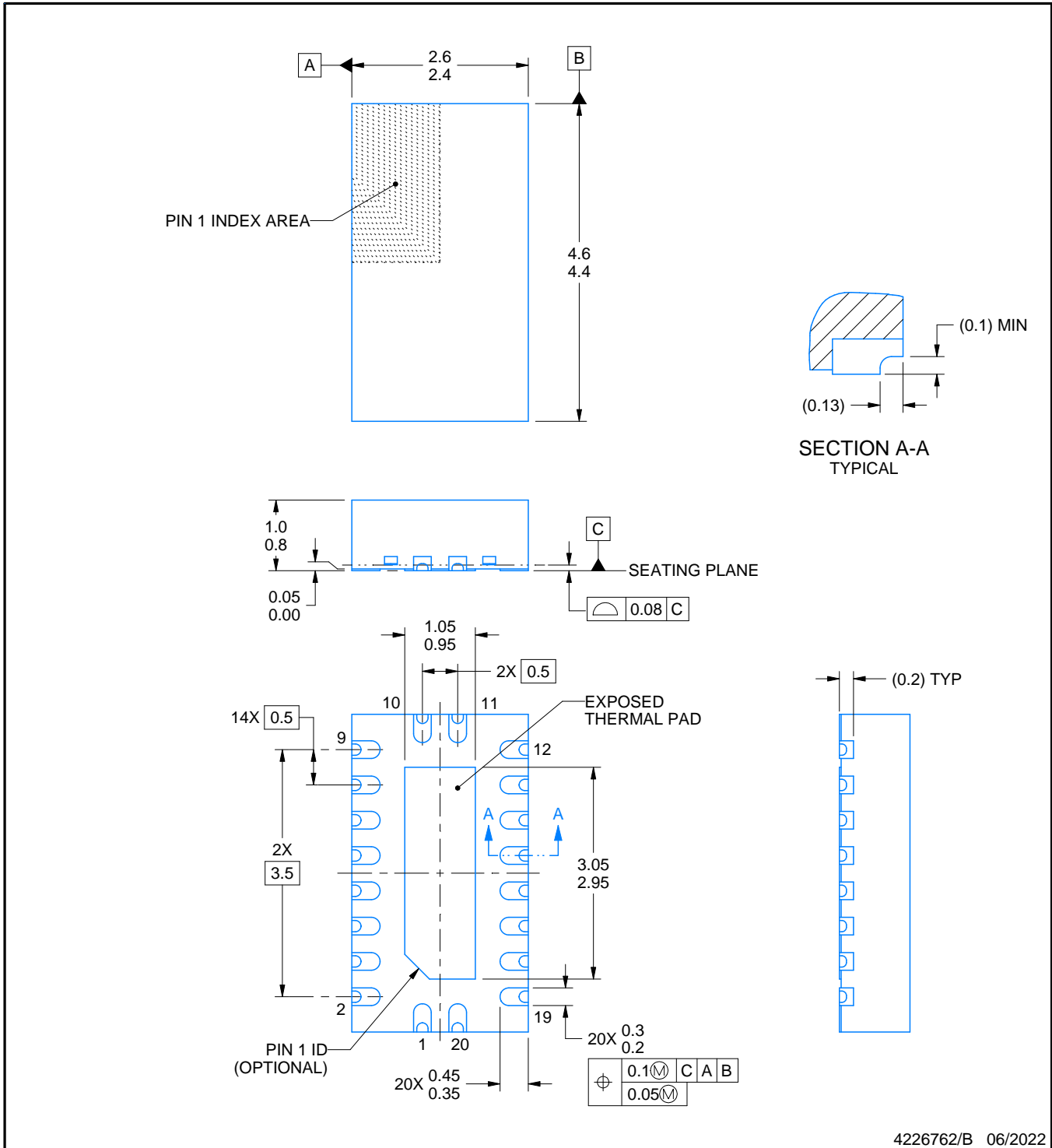

4226762/B 06/2022

NOTES:

1. All linear dimensions are in millimeters. Any dimensions in parenthesis are for reference only. Dimensioning and tolerancing per ASME Y14.5M.
2. This drawing is subject to change without notice.
3. The package thermal pad must be soldered to the printed circuit board for thermal and mechanical performance.

EXAMPLE STENCIL DESIGN

RKS0020B

VQFN - 1 mm max height

PLASTIC QUAD FLATPACK - NO LEAD

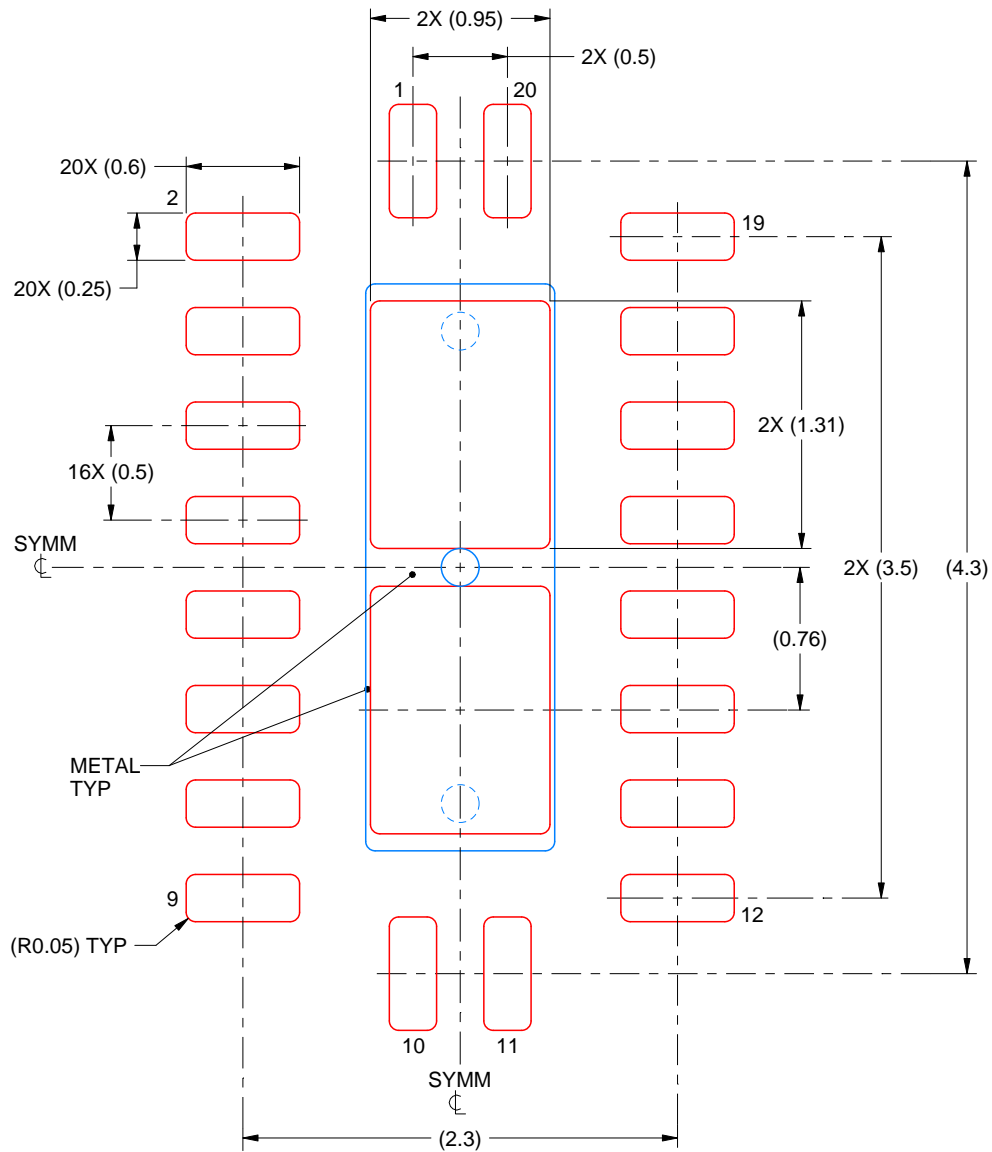

SOLDER PASTE EXAMPLE
 BASED ON 0.125 mm THICK STENCIL

EXPOSED PAD
 83% PRINTED SOLDER COVERAGE BY AREA
 SCALE:25X

4226762/B 06/2022

NOTES: (continued)

6. Laser cutting apertures with trapezoidal walls and rounded corners may offer better paste release. IPC-7525 may have alternate design recommendations.

重要声明和免责声明

TI“按原样”提供技术和可靠性数据（包括数据表）、设计资源（包括参考设计）、应用或其他设计建议、网络工具、安全信息和其他资源，不保证没有瑕疵且不做任何明示或暗示的担保，包括但不限于对适销性、某特定用途方面的适用性或不侵犯任何第三方知识产权的暗示担保。

这些资源可供使用 TI 产品进行设计的熟练开发人员使用。您将自行承担以下全部责任：(1) 针对您的应用选择合适的 TI 产品，(2) 设计、验证并测试您的应用，(3) 确保您的应用满足相应标准以及任何其他功能安全、信息安全、监管或其他要求。

这些资源如有变更，恕不另行通知。TI 授权您仅可将这些资源用于研发本资源所述的 TI 产品的应用。严禁对这些资源进行其他复制或展示。您无权使用任何其他 TI 知识产权或任何第三方知识产权。您应全额赔偿因在这些资源的使用中对 TI 及其代表造成的任何索赔、损害、成本、损失和债务，TI 对此概不负责。

TI 提供的产品受 [TI 的销售条款](#) 或 [ti.com](#) 上其他适用条款/TI 产品随附的其他适用条款的约束。TI 提供这些资源并不会扩展或以其他方式更改 TI 针对 TI 产品发布的适用的担保或担保免责声明。

TI 反对并拒绝您可能提出的任何其他或不同的条款。

邮寄地址：Texas Instruments, Post Office Box 655303, Dallas, Texas 75265

Copyright © 2022，德州仪器 (TI) 公司