

SN54125, SN54126, SN54LS125A, SN54LS126A, SN74125, SN74126, SN74LS125A, SN74LS126A QUADRUPLE BUS BUFFERS WITH 3-STATE OUTPUTS

SDLS044A - DECEMBER 1983 - REVISED MARCH 2002

The SN54125, SN54126, SN74125, SN74126, and SN54LS126A are obsolete and are no longer supplied.

- Quad Bus Buffers
- 3-State Outputs
- Separate Control for Each Channel

description

These bus buffers feature three-state outputs that, when enabled, have the low impedance characteristics of a TTL output with additional drive capability at high logic levels to permit driving heavily loaded bus lines without external pullup resistors. When disabled, both output transistors are turned off, presenting a high-impedance state to the bus so the output will act neither as a significant load nor as a driver. The '125 and 'LS125A devices' outputs are disabled when \bar{G} is high. The '126 and 'LS126A devices' outputs are disabled when G is low.

SN54125, SN54126, SN54LS125A,
SN54LS126A . . . J OR W PACKAGE
SN74125, SN74126 . . . N PACKAGE
SN74LS125A, SN74LS126A . . . D, N, OR NS PACKAGE
(TOP VIEW)

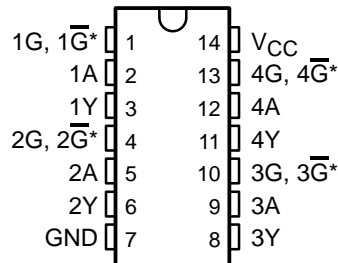

\bar{G} on '125 and 'LS125A devices;
G on 126 and 'LS126A devices

SN54LS125A, SN54LS126A . . . FK PACKAGE
(TOP VIEW)

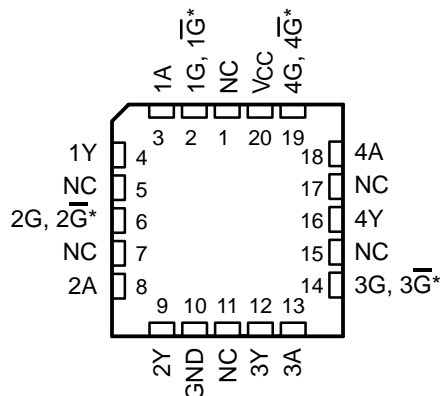

\bar{G} on '125 and 'LS125A devices;
G on 126 and 'LS126A devices
NC - No internal connection



Please be aware that an important notice concerning availability, standard warranty, and use in critical applications of Texas Instruments semiconductor products and disclaimers thereto appears at the end of this data sheet.

PRODUCTION DATA information is current as of publication date. Products conform to specifications per the terms of Texas Instruments standard warranty. Production processing does not necessarily include testing of all parameters.

**TEXAS
INSTRUMENTS**

POST OFFICE BOX 655303 • DALLAS, TEXAS 75265

Copyright © 2002, Texas Instruments Incorporated
On products compliant to MIL-PRF-38535, all parameters are tested unless otherwise noted. On all other products, production processing does not necessarily include testing of all parameters.

**SN54125, SN54126, SN54LS125A, SN54LS126A,
SN74125, SN74126, SN74LS125A, SN74LS126A
QUADRUPLE BUS BUFFERS WITH 3-STATE OUTPUTS**

SDLS044A – DECEMBER 1983 – REVISED MARCH 2002

The SN54125, SN54126, SN74125,
SN74126, and SN54LS126A are
obsolete and are no longer supplied.

ORDERING INFORMATION

T _A	PACKAGE†		ORDERABLE PART NUMBER	TOP-SIDE MARKING
0°C to 70°C	PDIP – N	Tube	SN74LS125AN	SN74LS125AN
		Tube	SN74LS126AN	SN74LS126AN
	SOIC – D	Tube	SN74LS125AD	LS125A
		Tape and reel	SN74LS125ADR	
		Tube	SN74LS126AD	LS126A
		Tape and reel	SN74LS126ADR	
	SOP – NS	Tape and reel	SN74LS125ANSR	74LS125A
Tape and reel		SN74LS126ANSR	74LS126A	
–55°C to 125°C	CDIP – J	Tube	SN54LS125AJ	SN54LS125AJ
		Tube	SNJ54LS125AJ	SNJ54LS125AJ
	CFP – W	Tube	SNJ54LS125AW	SNJ54LS125AW
	LCCC – FK	Tube	SNJ54LS125AFK	SNJ54LS125AFK

† Package drawings, standard packing quantities, thermal data, symbolization, and PCB design guidelines are available at www.ti.com/sc/package.

logic diagram (each gate)

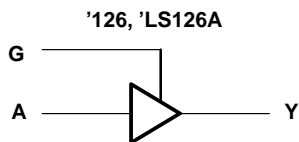
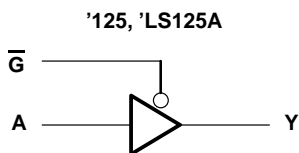

Y = A

**SN54125, SN54126, SN54LS125A, SN54LS126A,
SN74125, SN74126, SN74LS125A, SN74LS126A
QUADRUPLE BUS BUFFERS WITH 3-STATE OUTPUTS**

SDLS044A – DECEMBER 1983 – REVISED MARCH 2002

The SN54125, SN54126, SN74125,
SN74126, and SN54LS126A are
obsolete and are no longer supplied.

schematics (each gate)

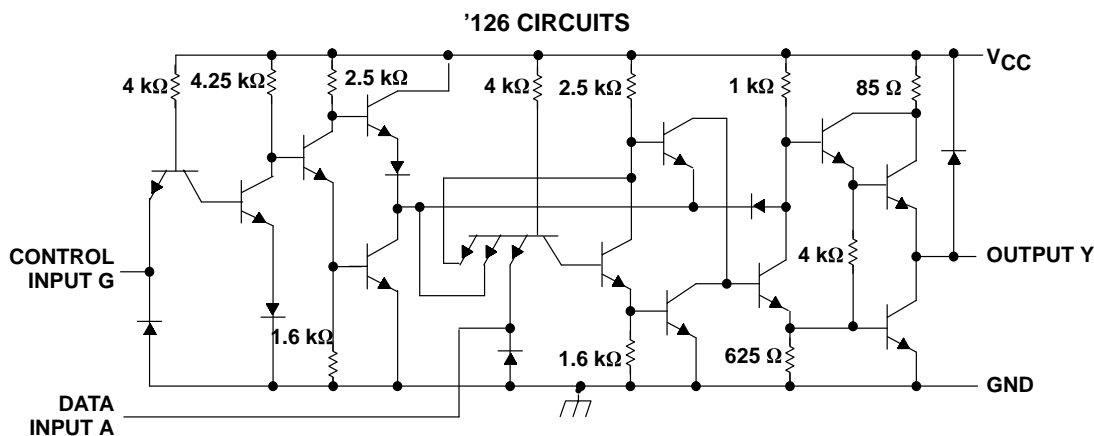
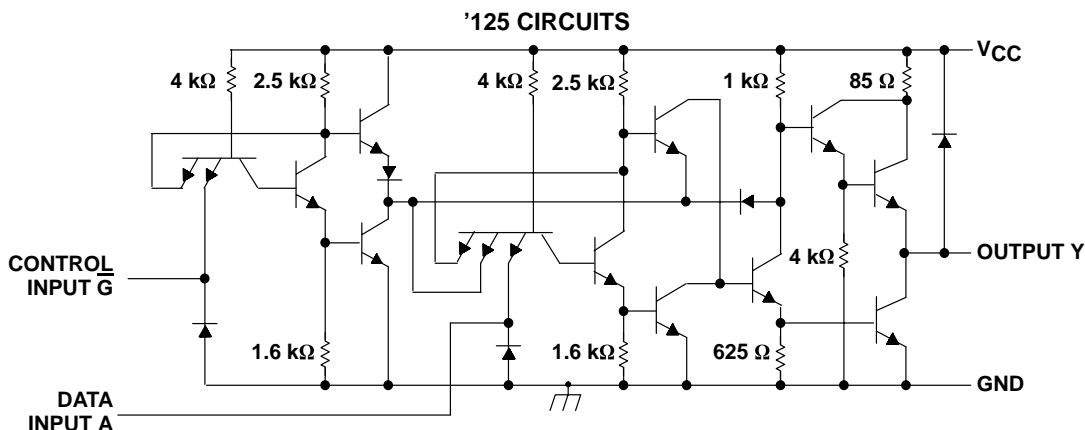

absolute maximum ratings over operating free-air temperature (unless otherwise noted)†
(**'125 and '126**)

Supply voltage, V_{CC} (see Note 1)	7 V
Input voltage, V_I	5.5 V
Package thermal impedance, θ_{JA} (see Note 2): N package	80°C/W
Storage temperature range, T_{stg}	-65°C to 150°C

† Stresses beyond those listed under "absolute maximum ratings" may cause permanent damage to the device. These are stress ratings only, and functional operation of the device at these or any other conditions beyond those indicated under "recommended operating conditions" is not implied. Exposure to absolute-maximum-rated conditions for extended periods may affect device reliability.

- NOTES: 1. Voltage values are with respect to network ground terminal.
2. The package thermal impedance is calculated in accordance with JESD 51-7.



The SN54125, SN54126, SN74125, SN74126, and SN54LS126A are obsolete and are no longer supplied.

SN54125, SN54126, SN54LS125A, SN54LS126A, SN74125, SN74126, SN74LS125A, SN74LS126A QUADRUPLE BUS BUFFERS WITH 3-STATE OUTPUTS

SDLS044A - DECEMBER 1983 - REVISED MARCH 2002

recommended operating conditions

		SN54125 SN54126			SN74125 SN74126			UNIT
		MIN	NOM	MAX	MIN	NOM	MAX	
V _{CC}	Supply voltage	4.5	5	5.5	4.75	5	5.25	V
V _{IH}	High-level input voltage	2			2			V
V _{IL}	Low-level input voltage			0.8			0.8	V
I _{OH}	High-level output current			-2			-5.2	mA
I _{OL}	Low-level output current			16			16	mA
T _A	Operating free-air temperature	-55		125	0		70	°C

electrical characteristics over recommended operating free-air temperature range (unless otherwise noted)

PARAMETER	TEST CONDITIONS†		SN54125 SN54126			SN74125 SN74126			UNIT	
			MIN	TYP‡	MAX	MIN	TYP‡	MAX		
V _{IK}	V _{CC} = MIN, I _I = -12 mA				-1.5			-1.5	V	
V _{OH}	V _{CC} = MIN, V _{IL} = 0.8 V	V _{IH} = 2 V, I _{OH} = -2 mA	2.4	3.3					V	
		V _{IH} = 2 V, I _{OH} = -5.2 mA				2.4	3.1			
V _{OL}	V _{CC} = MIN, I _{OL} = 16 mA	V _{IH} = 2 V, V _{IL} = 0.8 V			0.4			0.4	V	
I _{OZ}	V _{CC} = MAX, V _{IL} = 0.8 V	V _{IH} = 2 V, V _O = 2.4 V			40			40	μA	
		V _{IH} = 2 V, V _O = 0.4 V			-40			-40		
I _I	V _{CC} = MAX, V _I = 6.5 V				1			1	mA	
I _{IH}	V _{CC} = MAX, V _I = 2.4 V				40			40	μA	
I _{IL}	V _{CC} = MAX, V _I = 0.4 V				-1.6			-1.6	mA	
I _{OS} §	V _{CC} = MAX				-30		-70	-28	-70	mA
I _{CC}	V _{CC} = MAX (see Note 3)	'125	32	54			32	54	mA	
		'126	36	62			36	62		

† For conditions shown as MIN or MAX, use the appropriate value specified under recommended operating conditions.

‡ All typical values are at V_{CC} = 5 V, T_A = 25°C.

§ Not more than one output should be shorted at a time.

NOTE 3: Data inputs = 0 V; output control = 4.5 V for '125 and 0 V for '126.

switching characteristics, V_{CC} = 5 V, T_A = 25°C (see Figure 1)

PARAMETER	TEST CONDITIONS		SN54125 SN74125			SN54126 SN74126			UNIT
			MIN	TYP	MAX	MIN	TYP	MAX	
t _{PLH}	R _L = 400 Ω, C _L = 50 pF		8	13		8	13	ns	
t _{PHL}			12	18		12	18		
t _{PZH}	R _L = 400 Ω, C _L = 50 pF		11	17		11	18	ns	
t _{PZL}			16	25		16	25		
t _{PHZ}	R _L = 400 Ω, C _L = 5 pF		5	8		10	16	ns	
t _{PLZ}			7	12		12	18		



**SN54125, SN54126, SN54LS125A, SN54LS126A,
SN74125, SN74126, SN74LS125A, SN74LS126A
QUADRUPLE BUS BUFFERS WITH 3-STATE OUTPUTS**

SDLS044A – DECEMBER 1983 – REVISED MARCH 2002

The SN54125, SN54126, SN74125,
SN74126, and SN54LS126A are
obsolete and are no longer supplied.

recommended operating conditions

		SN54LS125A SN54LS126A			SN74LS125A SN74LS126A			UNIT
		MIN	NOM	MAX	MIN	NOM	MAX	
V _{CC}	Supply voltage	4.5	5	5.5	4.75	5	5.25	V
V _{IH}	High-level input voltage	2			2			V
V _{IL}	Low-level input voltage			0.7			0.8	V
I _{OH}	High-level output current			-1			-2.6	mA
I _{OL}	Low-level output current			12			24	mA
T _A	Operating free-air temperature	-55		125	0		70	°C

electrical characteristics over recommended operating free-air temperature range (unless otherwise noted)

PARAMETER	TEST CONDITIONS†		SN54LS125A SN54LS126A			SN74LS125A SN74LS126A			UNIT			
			MIN	TYP‡	MAX	MIN	TYP‡	MAX				
V _{IK}	V _{CC} = MIN, I _I = -18 mA		-1.5			-1.5			V			
V _{OH}	V _{CC} = MIN, V _{IH} = 2 V	V _{IL} = 0.7 V, I _{OH} = -1 mA	2.4						V			
		V _{IL} = 0.8 V, I _{OH} = -2.6 mA				2.4						
V _{OL}	V _{CC} = MIN, V _{IH} = 2 V	V _{IL} = 0.7 V, I _{OL} = 12 mA	0.25		0.4				V			
		V _{IL} = 0.8 V, I _{OL} = 12 mA			0.25		0.4					
		V _{IL} = 0.8 V, I _{OL} = 24 mA			0.35		0.5					
I _{OZ}	V _{CC} = MAX, V _{IH} = 2 V,	V _{IL} = 0.7 V	V _O = 2.4 V		20			μA				
			V _O = 0.4 V		-20							
		V _{IL} = 0.8 V	V _O = 2.4 V		20							
			V _O = 0.4 V		-20							
I _I	V _{CC} = MAX, V _I = 7 V		0.1			0.1			mA			
I _{IH}	V _{CC} = MAX, V _I = 2.7 V		20			20			μA			
I _{IL}	V _{CC} = MAX, V _I = 0.4 V	'LS125A-G inputs		-0.2			-0.2			mA		
		'LS125A-A inputs; 'LS126A All inputs		-0.4			-0.4					
I _{OS} §	V _{CC} = MAX		-40		-225		-40		-225		mA	
I _{CC}	V _{CC} = MAX (see Note 4)	'LS125A		11		20		11		20		mA
		'LS126A		12		22		12		22		

† For conditions shown as MIN or MAX, use the appropriate value specified under recommended operating conditions.

‡ All typical values are at V_{CC} = 5 V, T_A = 25°C.

§ Not more than one output should be shorted at a time, and the duration of the short circuit should not exceed one second.

NOTE 4: Data inputs = 0 V; output control = 4.5 V for 'LS125A and 0 V for 'LS126A.

switching characteristics, V_{CC} = 5 V, T_A = 25°C (see Figure 1)

PARAMETER	TEST CONDITIONS		SN54LS125A SN74LS125A			SN54LS126A SN74LS126A			UNIT		
			MIN	TYP	MAX	MIN	TYP	MAX			
t _{PLH}	R _L = 667 Ω,	C _L = 45 pF	9		15		9		15		ns
t _{PHL}			7		18		8		18		
t _{PZH}	R _L = 667 Ω,	C _L = 45 pF	12		20		16		25		ns
t _{PZL}			15		25		21		35		
t _{PHZ}	R _L = 667 Ω,	C _L = 5 pF			20				25		ns
t _{PLZ}					20				25		



PARAMETER MEASUREMENT INFORMATION
SERIES 54/74 DEVICES

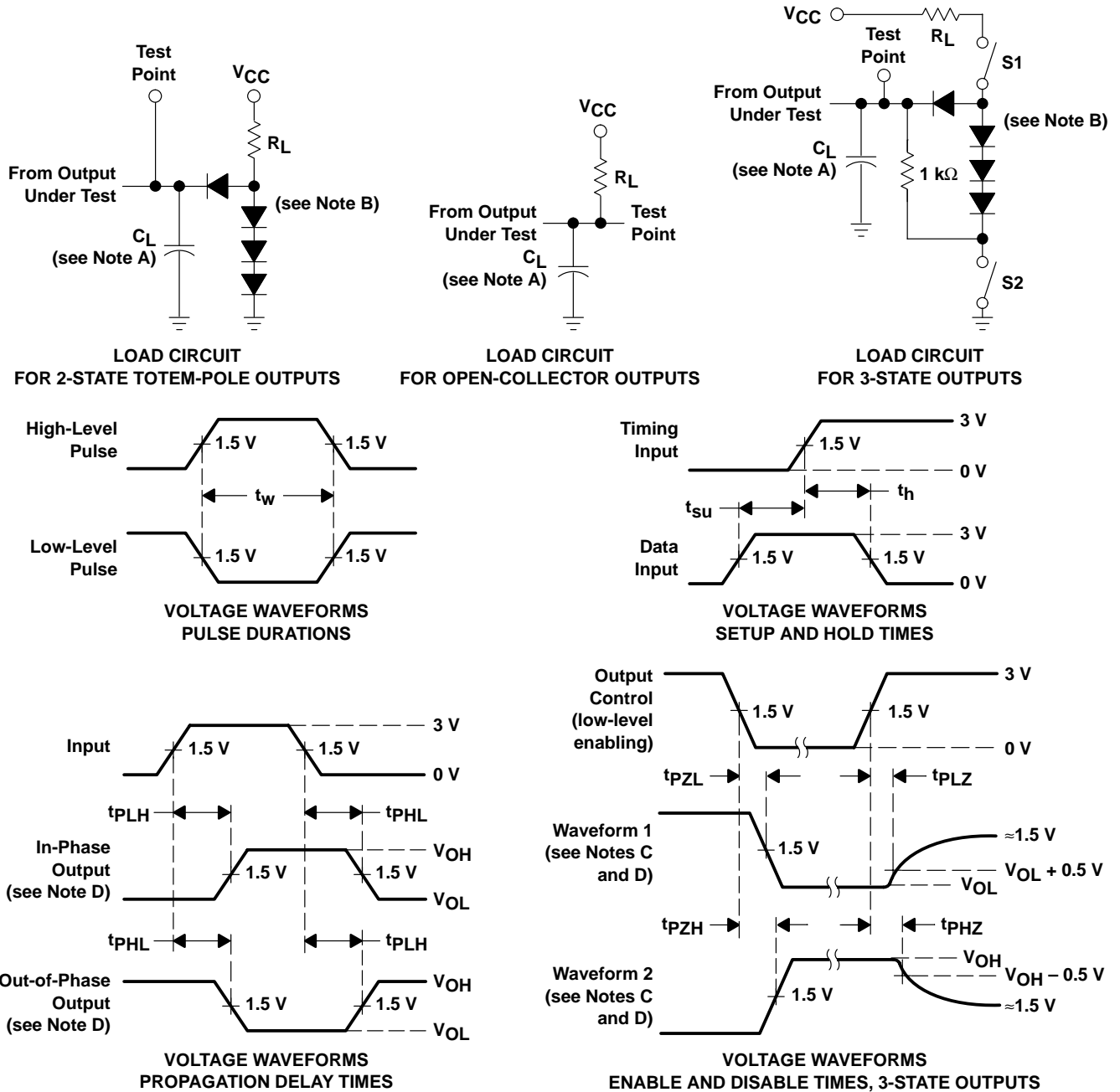

- NOTES: A. C_L includes probe and jig capacitance.
 B. All diodes are 1N3064 or equivalent.
 C. Waveform 1 is for an output with internal conditions such that the output is low except when disabled by the output control. Waveform 2 is for an output with internal conditions such that the output is high except when disabled by the output control.
 D. S1 and S2 are closed for t_{PLH} , t_{PHL} , t_{PHZ} , and t_{PLZ} ; S1 is open and S2 is closed for t_{PZH} ; S1 is closed and S2 is open for t_{PZL} .
 E. All input pulses are supplied by generators having the following characteristics: $PRR \leq 1$ MHz, $Z_O \approx 50 \Omega$; t_r and $t_f \leq 7$ ns for Series 54/74 devices and t_r and $t_f \leq 2.5$ ns for Series 54S/74S devices.
 F. The outputs are measured one at a time with one input transition per measurement.

Figure 1. Load Circuits and Voltage Waveforms

PARAMETER MEASUREMENT INFORMATION
SERIES 54LS/74LS DEVICES

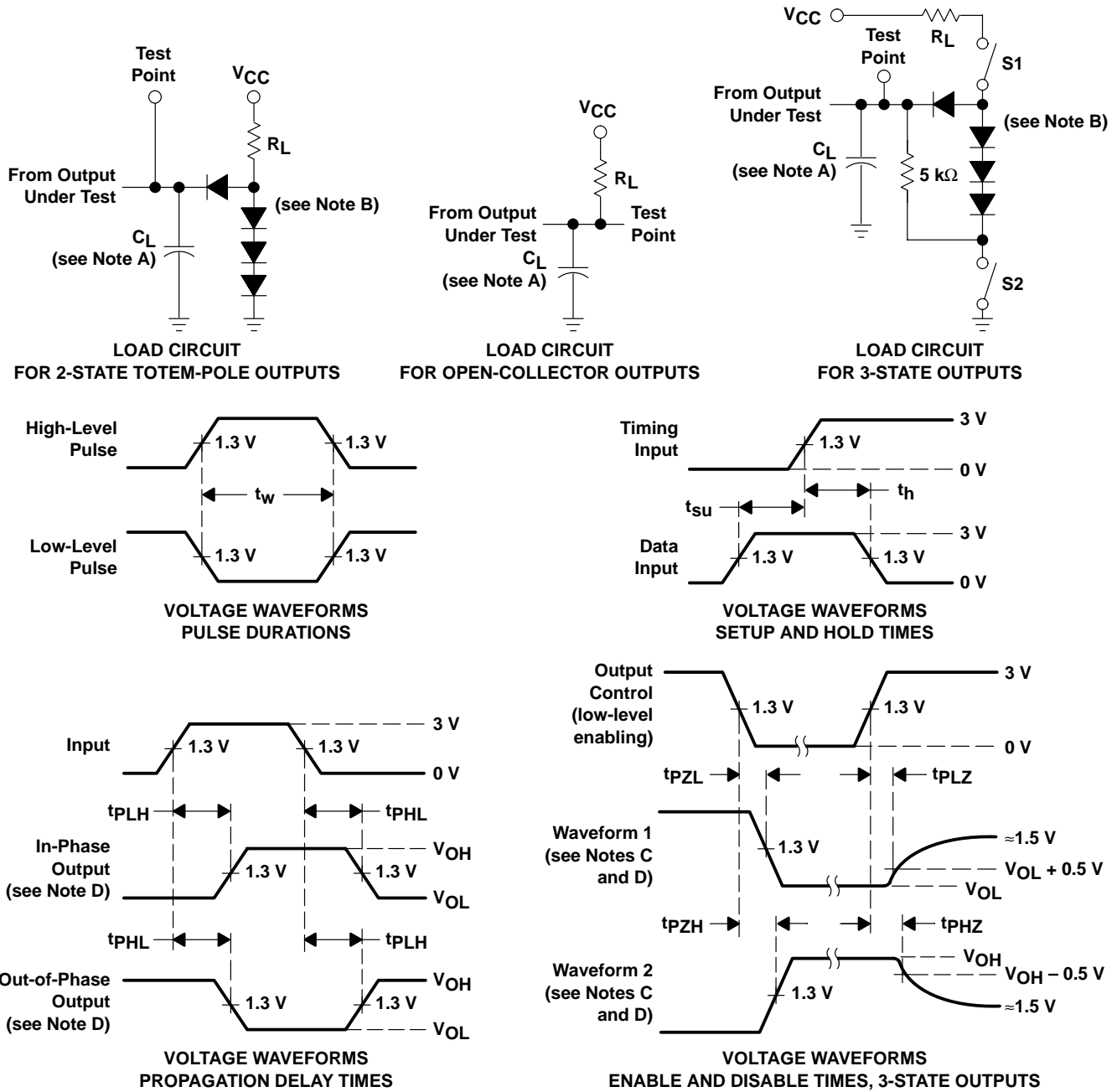

- NOTES: A. C_L includes probe and jig capacitance.
B. All diodes are 1N3064 or equivalent.
C. Waveform 1 is for an output with internal conditions such that the output is low except when disabled by the output control. Waveform 2 is for an output with internal conditions such that the output is high except when disabled by the output control.
D. S1 and S2 are closed for t_{PLH} , t_{PHL} , t_{PHZ} , and t_{PLZ} ; S1 is open and S2 is closed for t_{PZH} ; S1 is closed and S2 is open for t_{PZL} .
E. Phase relationships between inputs and outputs have been chosen arbitrarily for these examples.
F. All input pulses are supplied by generators having the following characteristics: $PRR \leq 1$ MHz, $Z_O \approx 50 \Omega$, $t_r \leq 1.5$ ns, $t_f \leq 2.6$ ns.
G. The outputs are measured one at a time with one input transition per measurement.

Figure 2. Load Circuits and Voltage Waveforms

PACKAGING INFORMATION

Orderable Device	Status (1)	Package Type	Package Drawing	Pins	Package Qty	Eco Plan (2)	Lead finish/ Ball material (6)	MSL Peak Temp (3)	Op Temp (°C)	Device Marking (4/5)	Samples
JM38510/32301B2A	ACTIVE	LCCC	FK	20	1	Non-RoHS & Green	SNPB	N / A for Pkg Type	-55 to 125	JM38510/ 32301B2A	Samples
JM38510/32301BCA	ACTIVE	CDIP	J	14	1	Non-RoHS & Green	SNPB	N / A for Pkg Type	-55 to 125	JM38510/ 32301BCA	Samples
JM38510/32301BDA	ACTIVE	CFP	W	14	1	Non-RoHS & Green	SNPB	N / A for Pkg Type	-55 to 125	JM38510/ 32301BDA	Samples
M38510/32301B2A	ACTIVE	LCCC	FK	20	1	Non-RoHS & Non-Green	SNPB	N / A for Pkg Type	-55 to 125	JM38510/ 32301B2A	Samples
M38510/32301BCA	ACTIVE	CDIP	J	14	1	Non-RoHS & Green	SNPB	N / A for Pkg Type	-55 to 125	JM38510/ 32301BCA	Samples
M38510/32301BDA	ACTIVE	CFP	W	14	1	Non-RoHS & Green	SNPB	N / A for Pkg Type	-55 to 125	JM38510/ 32301BDA	Samples
SN54LS125AJ	ACTIVE	CDIP	J	14	1	Non-RoHS & Green	SNPB	N / A for Pkg Type	-55 to 125	SN54LS125AJ	Samples
SN74LS125AD	ACTIVE	SOIC	D	14	50	RoHS & Green	NIPDAU	Level-1-260C-UNLIM	0 to 70	LS125A	Samples
SN74LS125ADBR	ACTIVE	SSOP	DB	14	2000	RoHS & Green	NIPDAU	Level-1-260C-UNLIM	0 to 70	LS125A	Samples
SN74LS125ADR	ACTIVE	SOIC	D	14	2500	RoHS & Green	NIPDAU	Level-1-260C-UNLIM	0 to 70	LS125A	Samples
SN74LS125ADRE4	ACTIVE	SOIC	D	14	2500	RoHS & Green	NIPDAU	Level-1-260C-UNLIM	0 to 70	LS125A	Samples
SN74LS125AN	ACTIVE	PDIP	N	14	25	RoHS & Green	NIPDAU	N / A for Pkg Type	0 to 70	SN74LS125AN	Samples
SN74LS125ANSR	ACTIVE	SO	NS	14	2000	RoHS & Green	NIPDAU	Level-1-260C-UNLIM	0 to 70	74LS125A	Samples
SN74LS126AD	ACTIVE	SOIC	D	14	50	RoHS & Green	NIPDAU	Level-1-260C-UNLIM	0 to 70	LS126A	Samples
SN74LS126ADR	ACTIVE	SOIC	D	14	2500	RoHS & Green	NIPDAU	Level-1-260C-UNLIM	0 to 70	LS126A	Samples
SN74LS126AN	ACTIVE	PDIP	N	14	25	RoHS & Green	NIPDAU	N / A for Pkg Type	0 to 70	SN74LS126AN	Samples
SN74LS126ANSR	ACTIVE	SO	NS	14	2000	RoHS & Green	NIPDAU	Level-1-260C-UNLIM	0 to 70	74LS126A	Samples
SNJ54LS125AJ	ACTIVE	CDIP	J	14	1	Non-RoHS & Green	SNPB	N / A for Pkg Type	-55 to 125	SNJ54LS125AJ	Samples

Orderable Device	Status (1)	Package Type	Package Drawing	Pins	Package Qty	Eco Plan (2)	Lead finish/ Ball material (6)	MSL Peak Temp (3)	Op Temp (°C)	Device Marking (4/5)	Samples
SNJ54LS125AW	ACTIVE	CFP	W	14	1	Non-RoHS & Green	SNPB	N / A for Pkg Type	-55 to 125	SNJ54LS125AW	Samples

(1) The marketing status values are defined as follows:

ACTIVE: Product device recommended for new designs.

LIFEBUY: TI has announced that the device will be discontinued, and a lifetime-buy period is in effect.

NRND: Not recommended for new designs. Device is in production to support existing customers, but TI does not recommend using this part in a new design.

PREVIEW: Device has been announced but is not in production. Samples may or may not be available.

OBSOLETE: TI has discontinued the production of the device.

(2) **RoHS:** TI defines "RoHS" to mean semiconductor products that are compliant with the current EU RoHS requirements for all 10 RoHS substances, including the requirement that RoHS substance do not exceed 0.1% by weight in homogeneous materials. Where designed to be soldered at high temperatures, "RoHS" products are suitable for use in specified lead-free processes. TI may reference these types of products as "Pb-Free".

RoHS Exempt: TI defines "RoHS Exempt" to mean products that contain lead but are compliant with EU RoHS pursuant to a specific EU RoHS exemption.

Green: TI defines "Green" to mean the content of Chlorine (Cl) and Bromine (Br) based flame retardants meet JS709B low halogen requirements of <=1000ppm threshold. Antimony trioxide based flame retardants must also meet the <=1000ppm threshold requirement.

(3) MSL, Peak Temp. - The Moisture Sensitivity Level rating according to the JEDEC industry standard classifications, and peak solder temperature.

(4) There may be additional marking, which relates to the logo, the lot trace code information, or the environmental category on the device.

(5) Multiple Device Markings will be inside parentheses. Only one Device Marking contained in parentheses and separated by a "~" will appear on a device. If a line is indented then it is a continuation of the previous line and the two combined represent the entire Device Marking for that device.

(6) Lead finish/Ball material - Orderable Devices may have multiple material finish options. Finish options are separated by a vertical ruled line. Lead finish/Ball material values may wrap to two lines if the finish value exceeds the maximum column width.

Important Information and Disclaimer:The information provided on this page represents TI's knowledge and belief as of the date that it is provided. TI bases its knowledge and belief on information provided by third parties, and makes no representation or warranty as to the accuracy of such information. Efforts are underway to better integrate information from third parties. TI has taken and continues to take reasonable steps to provide representative and accurate information but may not have conducted destructive testing or chemical analysis on incoming materials and chemicals. TI and TI suppliers consider certain information to be proprietary, and thus CAS numbers and other limited information may not be available for release.

In no event shall TI's liability arising out of such information exceed the total purchase price of the TI part(s) at issue in this document sold by TI to Customer on an annual basis.

OTHER QUALIFIED VERSIONS OF SN54LS125A, SN74LS125A :

- Catalog : [SN74LS125A](#)
- Military : [SN54LS125A](#)

NOTE: Qualified Version Definitions:

- Catalog - TI's standard catalog product
- Military - QML certified for Military and Defense Applications

TAPE AND REEL INFORMATION

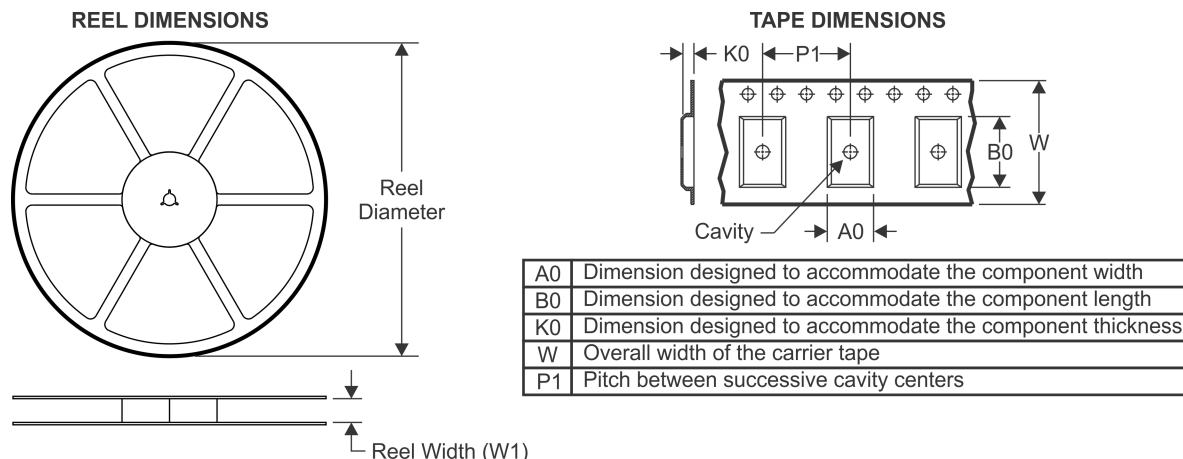

QUADRANT ASSIGNMENTS FOR PIN 1 ORIENTATION IN TAPE



*All dimensions are nominal

Device	Package Type	Package Drawing	Pins	SPQ	Reel Diameter (mm)	Reel Width W1 (mm)	A0 (mm)	B0 (mm)	K0 (mm)	P1 (mm)	W (mm)	Pin1 Quadrant
SN74LS125ADBR	SSOP	DB	14	2000	330.0	16.4	8.35	6.6	2.4	12.0	16.0	Q1
SN74LS125ADR	SOIC	D	14	2500	330.0	16.4	6.5	9.0	2.1	8.0	16.0	Q1
SN74LS125ANSR	SO	NS	14	2000	330.0	16.4	8.2	10.5	2.5	12.0	16.0	Q1
SN74LS126ADR	SOIC	D	14	2500	330.0	16.4	6.5	9.0	2.1	8.0	16.0	Q1
SN74LS126ANSR	SO	NS	14	2000	330.0	16.4	8.2	10.5	2.5	12.0	16.0	Q1

TAPE AND REEL BOX DIMENSIONS

*All dimensions are nominal

Device	Package Type	Package Drawing	Pins	SPQ	Length (mm)	Width (mm)	Height (mm)
SN74LS125ADBR	SSOP	DB	14	2000	853.0	449.0	35.0
SN74LS125ADR	SOIC	D	14	2500	853.0	449.0	35.0
SN74LS125ANSR	SO	NS	14	2000	853.0	449.0	35.0
SN74LS126ADR	SOIC	D	14	2500	853.0	449.0	35.0
SN74LS126ANSR	SO	NS	14	2000	853.0	449.0	35.0

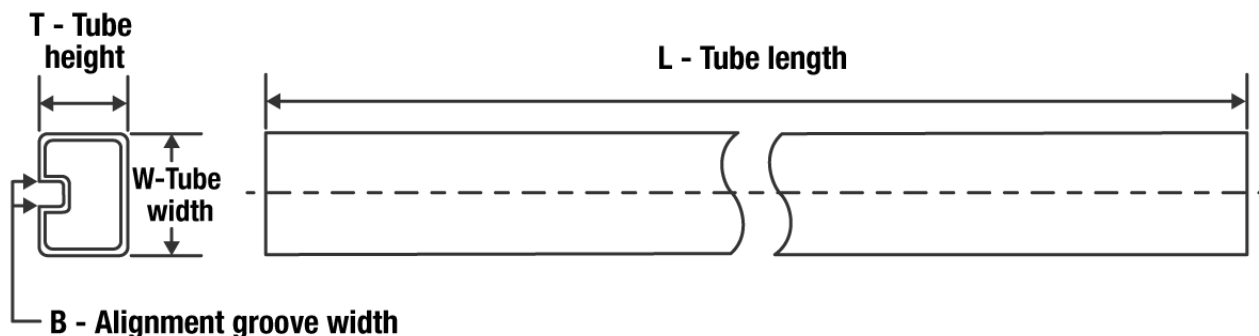
TUBE

*All dimensions are nominal

Device	Package Name	Package Type	Pins	SPQ	L (mm)	W (mm)	T (μm)	B (mm)
JM38510/32301B2A	FK	LCCC	20	1	506.98	12.06	2030	NA
M38510/32301B2A	FK	LCCC	20	1	506.98	12.06	2030	NA
SN74LS125AD	D	SOIC	14	50	506.6	8	3940	4.32
SN74LS125AN	N	PDIP	14	25	506	13.97	11230	4.32
SN74LS125AN	N	PDIP	14	25	506	13.97	11230	4.32
SN74LS126AD	D	SOIC	14	50	506.6	8	3940	4.32
SN74LS126AN	N	PDIP	14	25	506	13.97	11230	4.32
SN74LS126AN	N	PDIP	14	25	506	13.97	11230	4.32

FK (S-CQCC-N**)

LEADLESS CERAMIC CHIP CARRIER

28 TERMINAL SHOWN



NO. OF TERMINALS **	A		B	
	MIN	MAX	MIN	MAX
20	0.342 (8,69)	0.358 (9,09)	0.307 (7,80)	0.358 (9,09)
28	0.442 (11,23)	0.458 (11,63)	0.406 (10,31)	0.458 (11,63)
44	0.640 (16,26)	0.660 (16,76)	0.495 (12,58)	0.560 (14,22)
52	0.740 (18,78)	0.761 (19,32)	0.495 (12,58)	0.560 (14,22)
68	0.938 (23,83)	0.962 (24,43)	0.850 (21,6)	0.858 (21,8)
84	1.141 (28,99)	1.165 (29,59)	1.047 (26,6)	1.063 (27,0)



4040140/D 01/11

- NOTES:
- All linear dimensions are in inches (millimeters).
 - This drawing is subject to change without notice.
 - This package can be hermetically sealed with a metal lid.
 - Falls within JEDEC MS-004

MECHANICAL DATA

NS (R-PDSO-G**)

PLASTIC SMALL-OUTLINE PACKAGE

14-PINS SHOWN



- NOTES:
- A. All linear dimensions are in millimeters.
 - B. This drawing is subject to change without notice.
 - C. Body dimensions do not include mold flash or protrusion, not to exceed 0,15.

W (R-GDFP-F14)

CERAMIC DUAL FLATPACK



- NOTES:
- A. All linear dimensions are in inches (millimeters).
 - B. This drawing is subject to change without notice.
 - C. This package can be hermetically sealed with a ceramic lid using glass frit.
 - D. Index point is provided on cap for terminal identification only.
 - E. Falls within MIL STD 1835 GDFP1-F14

J 14

GENERIC PACKAGE VIEW
CDIP - 5.08 mm max height
CERAMIC DUAL IN LINE PACKAGE



Images above are just a representation of the package family, actual package may vary.
Refer to the product data sheet for package details.

4040083-5/G

J0014A



PACKAGE OUTLINE

CDIP - 5.08 mm max height

CERAMIC DUAL IN LINE PACKAGE



4214771/A 05/2017

NOTES:

1. All controlling linear dimensions are in inches. Dimensions in brackets are in millimeters. Any dimension in brackets or parenthesis are for reference only. Dimensioning and tolerancing per ASME Y14.5M.
2. This drawing is subject to change without notice.
3. This package is hermetically sealed with a ceramic lid using glass frit.
4. Index point is provided on cap for terminal identification only and on press ceramic glass frit seal only.
5. Falls within MIL-STD-1835 and GDIP1-T14.

EXAMPLE BOARD LAYOUT

J0014A

CDIP - 5.08 mm max height

CERAMIC DUAL IN LINE PACKAGE



LAND PATTERN EXAMPLE
NON-SOLDER MASK DEFINED
SCALE: 5X





4214771/A 05/2017

D (R-PDSO-G14)

PLASTIC SMALL OUTLINE



4040047-5/M 06/11

- NOTES:
- A. All linear dimensions are in inches (millimeters).
 - B. This drawing is subject to change without notice.
 -  Body length does not include mold flash, protrusions, or gate burrs. Mold flash, protrusions, or gate burrs shall not exceed 0.006 (0,15) each side.
 -  Body width does not include interlead flash. Interlead flash shall not exceed 0.017 (0,43) each side.
 - E. Reference JEDEC MS-012 variation AB.

D (R-PDSO-G14)

PLASTIC SMALL OUTLINE



- NOTES:
- All linear dimensions are in millimeters.
 - This drawing is subject to change without notice.
 - Publication IPC-7351 is recommended for alternate designs.
 - Laser cutting apertures with trapezoidal walls and also rounding corners will offer better paste release. Customers should contact their board assembly site for stencil design recommendations. Refer to IPC-7525 for other stencil recommendations.
 - Customers should contact their board fabrication site for solder mask tolerances between and around signal pads.

N (R-PDIP-T**)

PLASTIC DUAL-IN-LINE PACKAGE

16 PINS SHOWN



4040049/E 12/2002

- NOTES:
- A. All linear dimensions are in inches (millimeters).
 - B. This drawing is subject to change without notice.
 - Falls within JEDEC MS-001, except 18 and 20 pin minimum body length (Dim A).
 - The 20 pin end lead shoulder width is a vendor option, either half or full width.

DB (R-PDSO-G**)

PLASTIC SMALL-OUTLINE

28 PINS SHOWN



- NOTES: A. All linear dimensions are in millimeters.
 B. This drawing is subject to change without notice.
 C. Body dimensions do not include mold flash or protrusion not to exceed 0,15.
 D. Falls within JEDEC MO-150

IMPORTANT NOTICE AND DISCLAIMER

TI PROVIDES TECHNICAL AND RELIABILITY DATA (INCLUDING DATA SHEETS), DESIGN RESOURCES (INCLUDING REFERENCE DESIGNS), APPLICATION OR OTHER DESIGN ADVICE, WEB TOOLS, SAFETY INFORMATION, AND OTHER RESOURCES "AS IS" AND WITH ALL FAULTS, AND DISCLAIMS ALL WARRANTIES, EXPRESS AND IMPLIED, INCLUDING WITHOUT LIMITATION ANY IMPLIED WARRANTIES OF MERCHANTABILITY, FITNESS FOR A PARTICULAR PURPOSE OR NON-INFRINGEMENT OF THIRD PARTY INTELLECTUAL PROPERTY RIGHTS.

These resources are intended for skilled developers designing with TI products. You are solely responsible for (1) selecting the appropriate TI products for your application, (2) designing, validating and testing your application, and (3) ensuring your application meets applicable standards, and any other safety, security, regulatory or other requirements.

These resources are subject to change without notice. TI grants you permission to use these resources only for development of an application that uses the TI products described in the resource. Other reproduction and display of these resources is prohibited. No license is granted to any other TI intellectual property right or to any third party intellectual property right. TI disclaims responsibility for, and you will fully indemnify TI and its representatives against, any claims, damages, costs, losses, and liabilities arising out of your use of these resources.

TI's products are provided subject to [TI's Terms of Sale](#) or other applicable terms available either on ti.com or provided in conjunction with such TI products. TI's provision of these resources does not expand or otherwise alter TI's applicable warranties or warranty disclaimers for TI products.

TI objects to and rejects any additional or different terms you may have proposed.

Mailing Address: Texas Instruments, Post Office Box 655303, Dallas, Texas 75265
Copyright © 2022, Texas Instruments Incorporated