

SN5446A, '47A, '48, SN54LS47, 'LS48, 'LS49 SN7446A, '47A, '48, SN74LS47, 'LS48, 'LS49 BCD-TO-SEVEN-SEGMENT DECODERS/DRIVERS

SDLS111 – MARCH 1974 – REVISED MARCH 1988

'46A, '47A, 'LS47 feature

- Open-Collector Outputs Drive Indicators Directly
- Lamp-Test Provision
- Leading/Trailing Zero Suppression

'48, 'LS48 feature

- Internal Pull-Ups Eliminate Need for External Resistors
- Lamp-Test Provision
- Leading/Trailing Zero Suppression

'LS49 feature

- Open-Collector Outputs
- Blanking Input

SN5446A, SN5447A, SN54LS47, SN5448,
SN54LS48 . . . J PACKAGE
SN7446A, SN7447A,
SN7448 . . . N PACKAGE
SN74LS47, SN74LS48 . . . D OR N PACKAGE

(TOP VIEW)

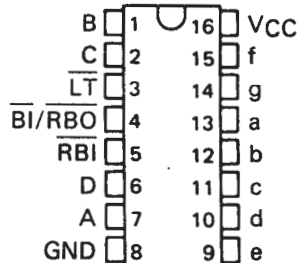

SN54LS47, SN54LS48 . . . FK PACKAGE
(TOP VIEW)

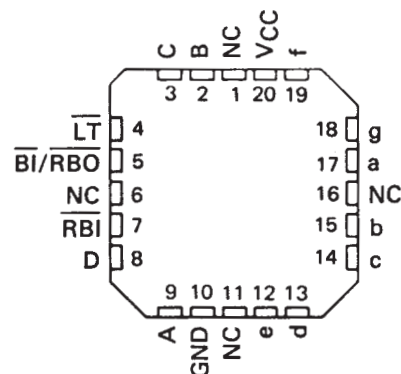

SN54LS49 . . . J OR W PACKAGE
SN74LS49 . . . D OR N PACKAGE

(TOP VIEW)

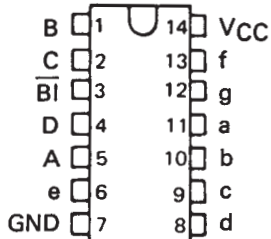

SN54LS49 . . . FK PACKAGE
(TOP VIEW)

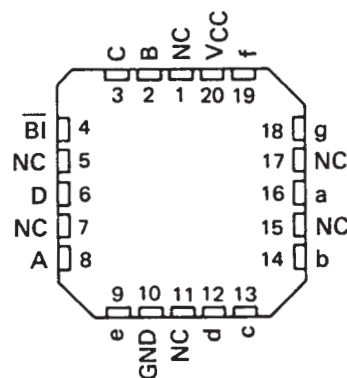

NC – No internal connection

PRODUCTION DATA information is current as of publication date. Products conform to specifications per the terms of Texas Instruments standard warranty. Production processing does not necessarily include testing of all parameters.

 **TEXAS
INSTRUMENTS**

POST OFFICE BOX 655303 • DALLAS, TEXAS 75265

Copyright © 1988, Texas Instruments Incorporated

SN5446A, '47A, '48, SN54LS47, 'LS48, 'LS49
 SN7446A, '47A, '48, SN74LS47, 'LS48, 'LS49
 BCD-TO-SEVEN-SEGMENT DECODERS/DRIVERS

SDLS111 – MARCH 1974 – REVISED MARCH 1988

- All Circuit Types Feature Lamp Intensity Modulation Capability

TYPE	DRIVER OUTPUTS				TYPICAL POWER DISSIPATION	PACKAGES
	ACTIVE LEVEL	OUTPUT CONFIGURATION	SINK CURRENT	MAX VOLTAGE		
SN5446A	low	open-collector	40 mA	30 V	320 mW	J, W
SN5447A	low	open-collector	40 mA	15 V	320 mW	J, W
SN5448	high	2-k Ω pull-up	6.4 mA	5.5 V	265 mW	J,W
SN54LS47	low	open-collector	12 mA	15 V	35 mW	J, W
SN54LS48	high	2-k Ω pull-up	2 mA	5.5 V	125 mW	J, W
SN54LS49	high	open-collector	4 mA	5.5 V	40 mW	J, W
SN7446A	low	open-collector	40 mA	30 V	320 mW	J, N
SN7447A	low	open-collector	40 mA	15 V	320 mW	J, N
SN7448	high	2-k Ω pull-up	6.4 mA	5.5 V	265 mW	J, N
SN74LS47	low	open-collector	24 mA	15 V	35 mW	J, N
SN74LS48	high	2-k Ω pull-up	6 mA	5.5 V	125 mW	J, N
SN74LS49	high	open-collector	8 mA	5.5 V	40 mW	J, N

logic symbols †

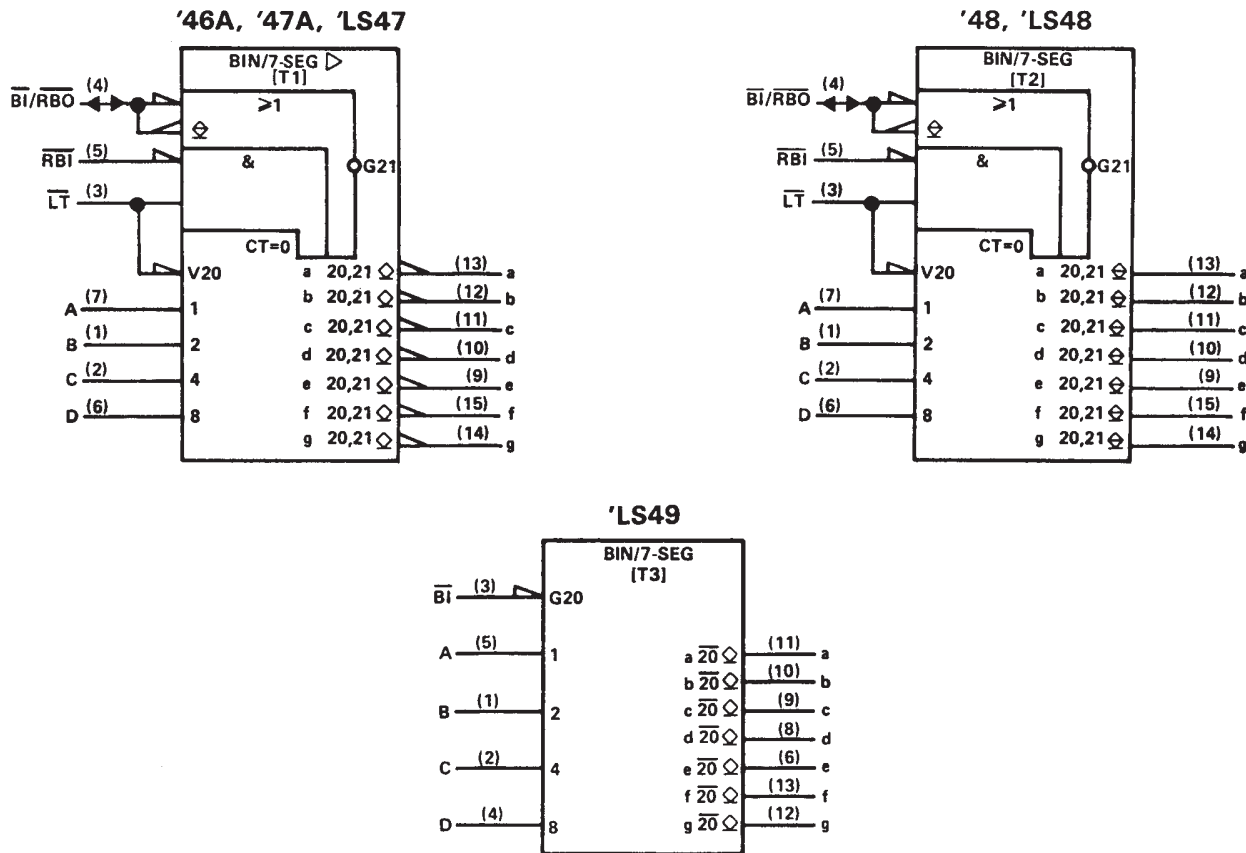

†These symbols are in accordance with ANSI/IEEE Std 91-1984 and IEC Publication 617-12. Pin numbers shown are for D, J, N, and W packages.

SN5446A, '47A, '48, SN54LS47, 'LS48, 'LS49 SN7446A, '47A, '48, SN74LS47, 'LS48, 'LS49 BCD-TO-SEVEN-SEGMENT DECODERS/DRIVERS

SDLS111 – MARCH 1974 – REVISED MARCH 1988

description

The '46A, '47A, and 'LS47 feature active-low outputs designed for driving common-anode LEDs or incandescent indicators directly. The '48, 'LS48, and 'LS49 feature active-high outputs for driving lamp buffers or common-cathode LEDs. All of the circuits except 'LS49 have full ripple-blanking input/output controls and a lamp test input. The 'LS49 circuit incorporates a direct blanking input. Segment identification and resultant displays are shown below. Display patterns for BCD input counts above 9 are unique symbols to authenticate input conditions.

The '46A, '47A, '48, 'LS47, and 'LS48 circuits incorporate automatic leading and/or trailing-edge zero-blanking control (\overline{RBI} and \overline{RBO}). Lamp test (\overline{LT}) of these types may be performed at any time when the $\overline{BI/RBO}$ node is at a high level. All types (including the '49 and 'LS49) contain an overriding blanking input (\overline{BI}), which can be used to control the lamp intensity by pulsing or to inhibit the outputs. Inputs and outputs are entirely compatible for use with TTL logic outputs.

The SN54246/SN74246 and '247 and the SN54LS247/SN74LS247 and 'LS248 compose the $\overline{6}$ and the $\overline{9}$ with tails and were designed to offer the designer a choice between two indicator fonts.

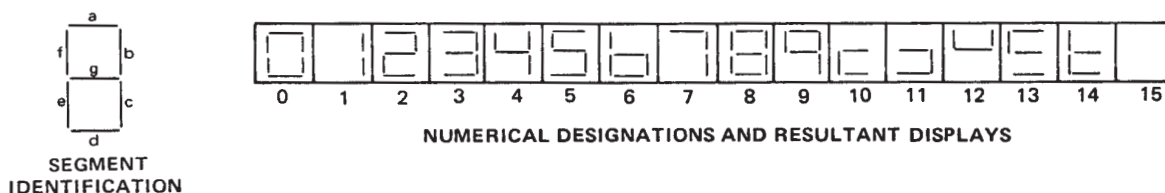

'46A, '47A, 'LS47 FUNCTION TABLE (T1)

DECIMAL OR FUNCTION	INPUTS						$\overline{BI/RBO}^\dagger$	OUTPUTS							NOTE	
	\overline{LT}	\overline{RBI}	D	C	B	A		a	b	c	d	e	f	g		
0	H	H	L	L	L	L	H	ON	ON	ON	ON	ON	ON	OFF	OFF	1
1	H	X	L	L	L	H	H	OFF	ON	ON	OFF	OFF	OFF	OFF	OFF	
2	H	X	L	L	H	L	H	ON	ON	OFF	ON	ON	OFF	ON	ON	
3	H	X	L	L	H	H	H	ON	ON	ON	ON	OFF	OFF	ON	ON	
4	H	X	L	H	L	L	H	OFF	ON	ON	OFF	OFF	ON	ON	ON	
5	H	X	L	H	L	H	H	ON	OFF	ON	ON	OFF	ON	ON	ON	
6	H	X	L	H	H	L	H	OFF	OFF	ON	ON	ON	ON	ON	ON	
7	H	X	L	H	H	H	H	ON	ON	ON	OFF	OFF	OFF	OFF	OFF	
8	H	X	H	L	L	L	H	ON	ON	ON	ON	ON	ON	ON	ON	
9	H	X	H	L	L	H	H	ON	ON	ON	OFF	OFF	ON	ON	ON	
10	H	X	H	L	H	L	H	OFF	OFF	OFF	ON	ON	OFF	ON	ON	
11	H	X	H	L	H	H	H	OFF	OFF	ON	ON	OFF	OFF	ON	ON	
12	H	X	H	H	L	L	H	OFF	ON	OFF	OFF	OFF	ON	ON	ON	
13	H	X	H	H	L	H	H	ON	OFF	OFF	ON	OFF	ON	ON	ON	
14	H	X	H	H	H	L	H	OFF	OFF	OFF	ON	ON	ON	ON	ON	
15	H	X	H	H	H	H	H	OFF	OFF	OFF	OFF	OFF	OFF	OFF	OFF	
BI	X	X	X	X	X	X	L	OFF	OFF	OFF	OFF	OFF	OFF	OFF	OFF	2
RBI	H	L	L	L	L	L	L	OFF	OFF	OFF	OFF	OFF	OFF	OFF	OFF	3
LT	L	X	X	X	X	X	H	ON	ON	ON	ON	ON	ON	ON	ON	4

H = high level, L = low level, X = irrelevant

NOTES: 1. The blanking input (\overline{BI}) must be open or held at a high logic level when output functions 0 through 15 are desired. The ripple-blanking input (\overline{RBI}) must be open or high if blanking of a decimal zero is not desired.

2. When a low logic level is applied directly to the blanking input (\overline{BI}), all segment outputs are off regardless of the level of any other input.

3. When ripple-blanking input (\overline{RBI}) and inputs A, B, C, and D are at a low level with the lamp test input high, all segment outputs go off and the ripple-blanking output (\overline{RBO}) goes to a low level (response condition).

4. When the blanking input/ripple blanking output ($\overline{BI/RBO}$) is open or held high and a low is applied to the lamp-test input, all segment outputs are on.

$^\dagger \overline{BI/RBO}$ is wire AND logic serving as blanking input (\overline{BI}) and/or ripple-blanking output (\overline{RBO}).



SN5446A, '47A, '48, SN54LS47, 'LS48, 'LS49
 SN7446A, '47A, '48, SN74LS47, 'LS48, 'LS49
 BCD-TO-SEVEN-SEGMENT DECODERS/DRIVERS

SDLS111 – MARCH 1974 – REVISED MARCH 1988

'48, 'LS48
 FUNCTION TABLE (T2)

DECIMAL OR FUNCTION	INPUTS					$\overline{BI}/\overline{RBO}^\dagger$	OUTPUTS							NOTE
	\overline{LT}	\overline{RBI}	D	C	B		A	a	b	c	d	e	f	
0	H	H	L	L	L	L	H	H	H	H	H	H	L	1
1	H	X	L	L	L	H	H	L	H	H	L	L	L	
2	H	X	L	L	H	L	H	H	H	L	H	H	L	
3	H	X	L	L	H	H	H	H	H	H	L	L	H	
4	H	X	L	H	L	L	H	L	H	H	L	L	H	
5	H	X	L	H	L	H	H	H	L	H	H	L	H	
6	H	X	L	H	H	L	H	L	L	H	H	H	H	
7	H	X	L	H	H	H	H	H	H	H	L	L	L	
8	H	X	H	L	L	L	H	H	H	H	H	H	H	
9	H	X	H	L	L	H	H	H	H	L	L	H	H	
10	H	X	H	L	H	L	H	L	L	L	H	H	L	
11	H	X	H	L	H	H	H	L	L	H	H	L	L	
12	H	X	H	H	L	L	H	L	H	L	L	L	H	
13	H	X	H	H	L	H	H	H	L	L	H	L	H	
14	H	X	H	H	H	L	H	L	L	L	H	H	H	
15	H	X	H	H	H	H	H	L	L	L	L	L	L	
BI	X	X	X	X	X	X	L	L	L	L	L	L	L	2
RBI	H	L	L	L	L	L	L	L	L	L	L	L	L	3
LT	L	X	X	X	X	X	H	H	H	H	H	H	H	4

H = high level, L = low level, X = irrelevant

- NOTES: 1. The blanking input (\overline{BI}) must be open or held at a high logic level when output functions 0 through 15 are desired. The ripple-blanking input (\overline{RBI}) must be open or high, if blanking of a decimal zero is not desired.
2. When a low logic level is applied directly to the blanking input (\overline{BI}), all segment outputs are low regardless of the level of any other input.
3. When ripple-blanking input (\overline{RBI}) and inputs A, B, C, and D are at a low level with the lamp-test input high, all segment outputs go low and the ripple-blanking output (\overline{RBO}) goes to a low level (response condition).
4. When the blanking input/ripple-blanking output ($\overline{BI}/\overline{RBO}$) is open or held high and a low is applied to the lamp-test input, all segment outputs are high.

$^\dagger \overline{BI}/\overline{RBO}$ is wire-AND logic serving as blanking input (\overline{BI}) and/or ripple-blanking output (\overline{RBO}).

'LS49
 FUNCTION TABLE (T3)

DECIMAL OR FUNCTION	INPUTS					\overline{BI}	OUTPUTS							NOTE
	D	C	B	A	a		b	c	d	e	f	g		
0	L	L	L	L	H	H	H	H	H	H	H	L	1	
1	L	L	L	H	H	L	H	H	L	L	L	L		
2	L	L	H	L	H	H	H	L	H	H	L	H		
3	L	L	H	H	H	H	H	H	H	L	L	H		
4	L	H	L	L	H	H	L	H	H	L	L	H		
5	L	H	L	H	H	H	L	H	H	L	H	H		
6	L	H	H	L	H	L	L	H	H	H	H	H		
7	L	H	H	H	H	H	H	H	L	L	L	L		
8	H	L	L	L	H	H	H	H	H	H	H	H		
9	H	L	L	H	H	H	H	H	L	L	H	H		
10	H	L	H	L	H	L	L	L	H	H	L	H		
11	H	L	H	H	H	L	L	H	H	L	L	H		
12	H	H	L	L	H	L	H	L	L	L	H	H		
13	H	H	L	H	H	H	L	L	L	H	L	H		
14	H	H	H	L	H	L	L	L	L	H	H	H		
15	H	H	H	H	H	L	L	L	L	L	L	L		
BI	X	X	X	X	L	L	L	L	L	L	L	L	2	

H = high level, L = low level, X = irrelevant

- NOTES: 1. The blanking input (\overline{BI}) must be open or held at a high logic level when output functions 0 through 15 are desired.
2. When a low logic level is applied directly to the blanking input (\overline{BI}), all segment outputs are low regardless of the level of any other input.



SN5446A, '47A, '48, SN54LS47, 'LS48, 'LS49
 SN7446A, '47A, '48, SN74LS47, 'LS48, 'LS49
 BCD-TO-SEVEN-SEGMENT DECODERS/DRIVERS

SDLS111 - MARCH 1974 - REVISED MARCH 1988

logic diagrams (positive logic)

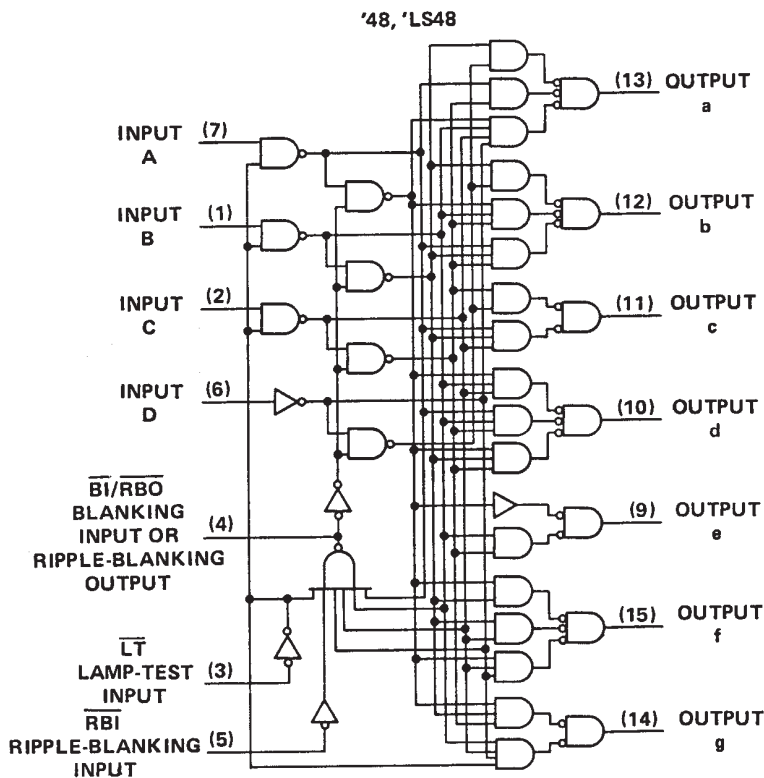
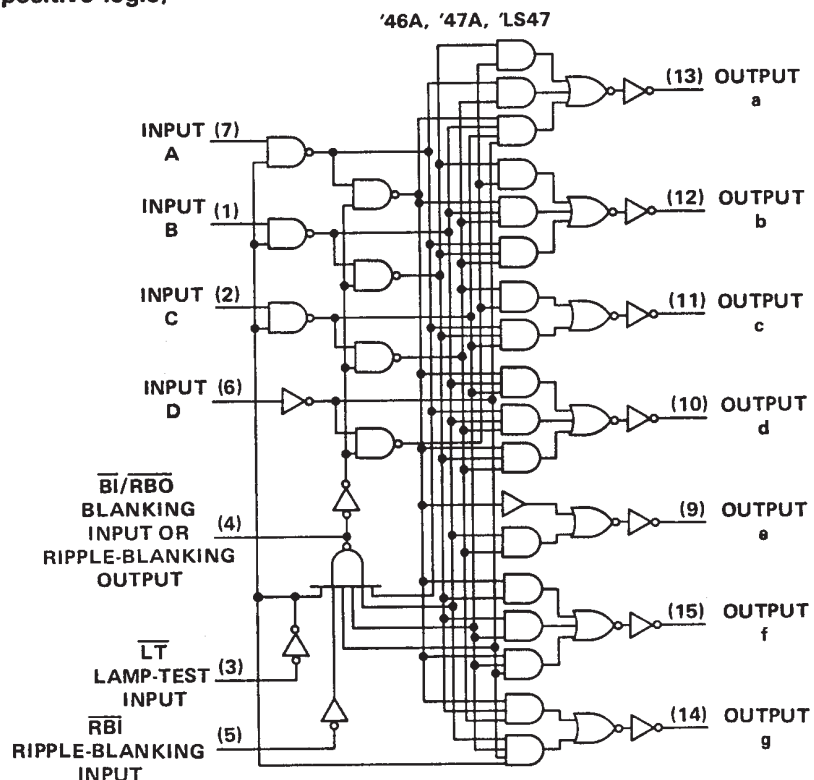

Pin numbers shown are for D, J, N, and W packages.



SN5446A, '47A, '48, SN54LS47, 'LS48, 'LS49
 SN7446A, '47A, '48, SN74LS47, 'LS48, 'LS49
 BCD-TO-SEVEN-SEGMENT DECODERS/DRIVERS

SDLS111 – MARCH 1974 – REVISED MARCH 1988

logic diagrams (continued)

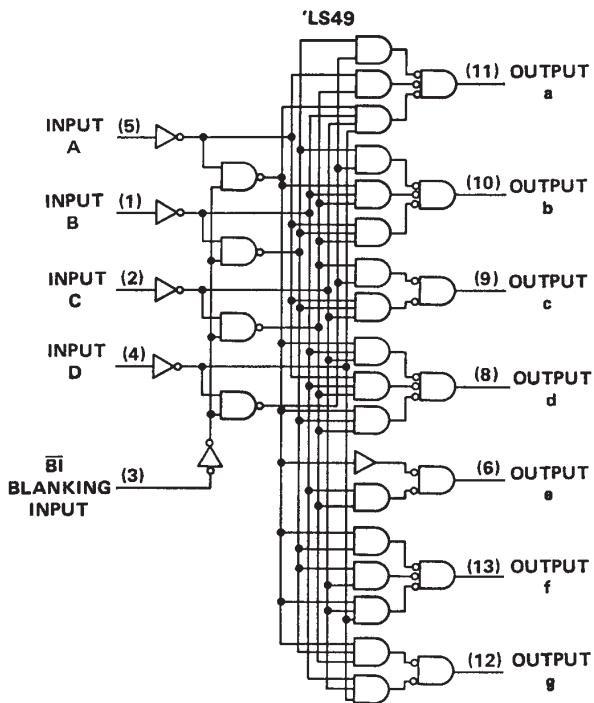

Pin numbers shown are for D, J, N, and W packages.

SN5446A, '47A, '48, SN54LS47, 'LS48, 'LS49
 SN7446A, '47A, '48, SN74LS47, 'LS48, 'LS49
 BCD-TO-SEVEN-SEGMENT DECODERS/DRIVERS

SDLS111 - MARCH 1974 - REVISED MARCH 1988

schematics of inputs and outputs

'46A, '47A, '48

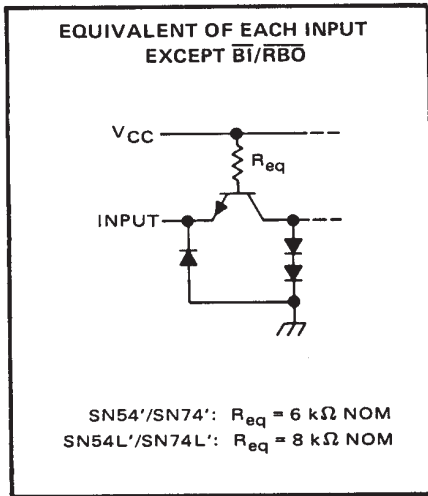

'46A, '47A, '48

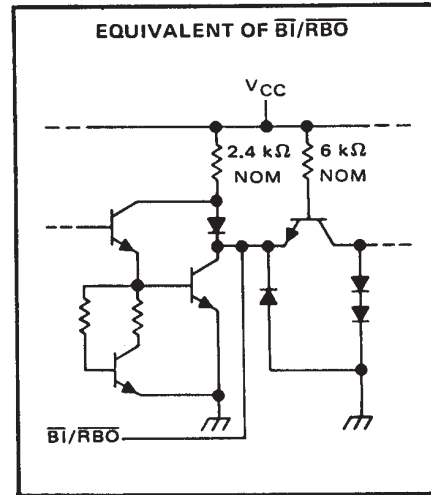

'46A, '47A

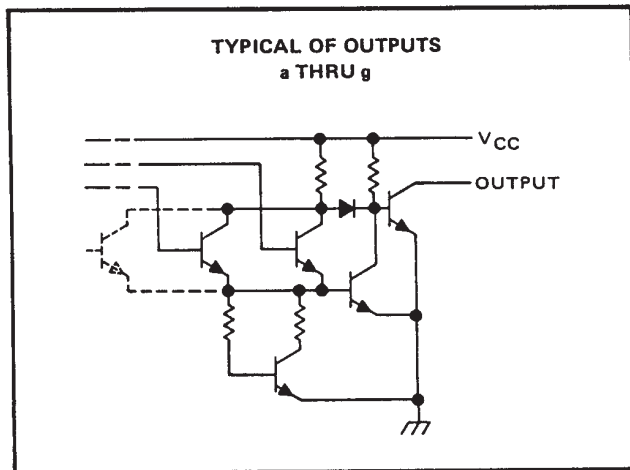

'48

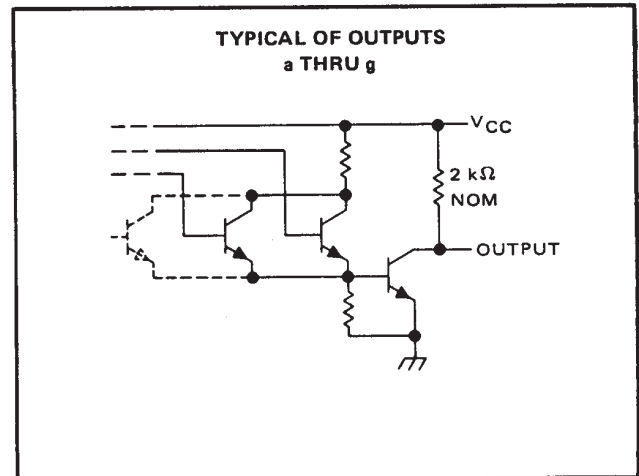

SN5446A, '47A, '48, SN54LS47, 'LS48, 'LS49
 SN7446A, '47A, '48, SN74LS47, 'LS48, 'LS49
 BCD-TO-SEVEN-SEGMENT DECODERS/DRIVERS

SDLS111 - MARCH 1974 - REVISED MARCH 1988

schematics of inputs and outputs

'LS47, 'LS48, 'LS49

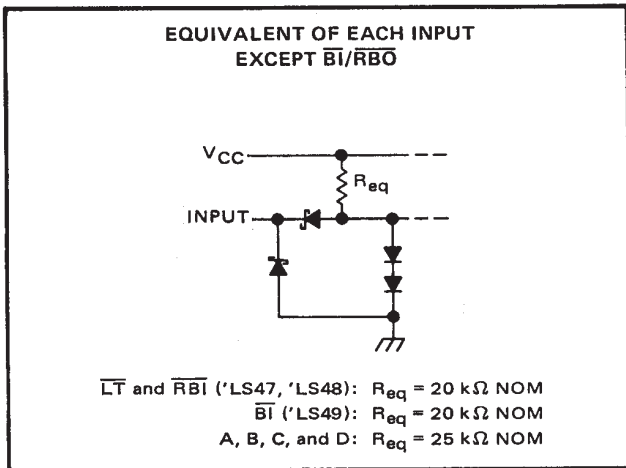

'LS47, 'LS48, 'LS49

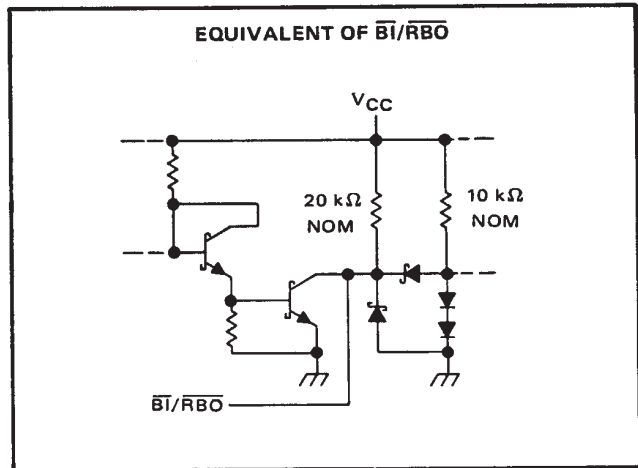

'LS47

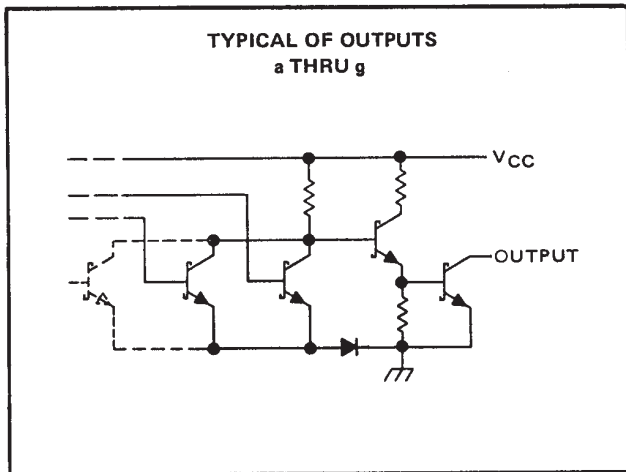

'LS48

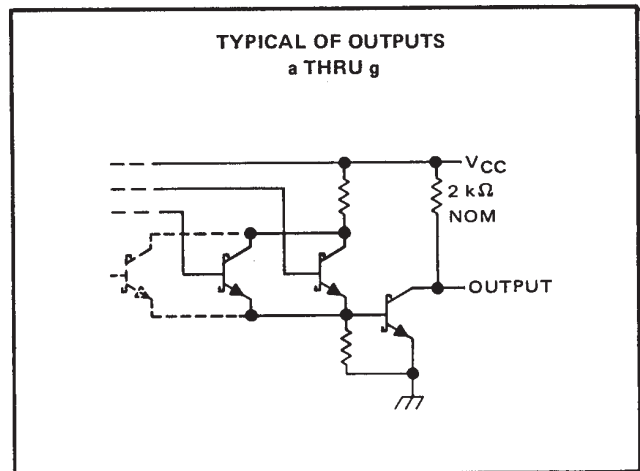

'LS49

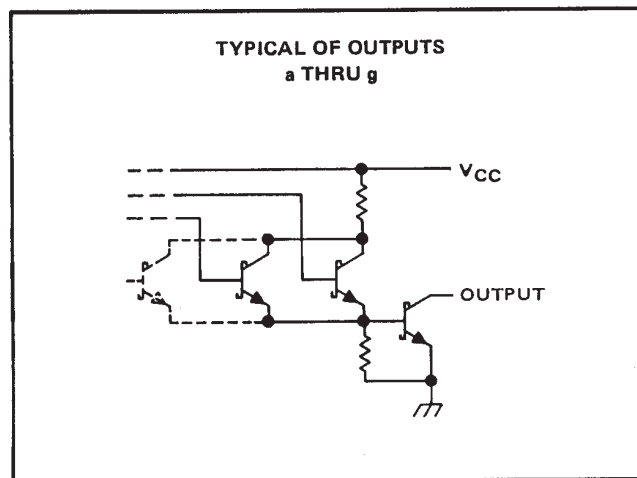

SN5446A, '47A, '48, SN54LS47, 'LS48, 'LS49
SN7446A, '47A, '48, SN74LS47, 'LS48, 'LS49
BCD-TO-SEVEN-SEGMENT DECODERS/DRIVERS

SDLS111 – MARCH 1974 – REVISED MARCH 1988

absolute maximum ratings over operating free-air temperature range (unless otherwise noted)

Supply voltage, V_{CC} (see Note 1)	7 V
Input voltage	5.5 V
Current forced into any output in the off state	1 mA
Operating free-air temperature range: SN5446A, SN5447A	–55°C to 125°C
SN7446A, SN7447A	0°C to 70°C
Storage temperature range	–65°C to 150°C

NOTE 1: Voltage values are with respect to network ground terminal.

recommended operating conditions

	SN5446A			SN5447A			SN7446A			SN7447A			UNIT		
	MIN	NOM	MAX	MIN	NOM	MAX	MIN	NOM	MAX	MIN	NOM	MAX			
Supply voltage, V_{CC}	4.5	5	5.5	4.5	5	5.5	4.75	5	5.25	4.75	5	5.25	V		
Off-state output voltage, $V_{O(off)}$	a thru g			30			15			30			15	V	
On-state output current, $I_{O(on)}$	a thru g			40			40			40			40	mA	
High-level output current, I_{OH}	$\overline{BI}/\overline{RBO}$			–200			–200			–200			–200	μ A	
Low-level output current, I_{OL}	$\overline{BI}/\overline{RBO}$			8			8			8			8	mA	
Operating free-air temperature, T_A	–55			125			–55			125			0	70	°C

electrical characteristics over recommended operating free-air temperature range (unless otherwise noted)

PARAMETER		TEST CONDITIONS†	MIN	TYP‡	MAX	UNIT
V_{IH}	High-level input voltage		2			V
V_{IL}	Low-level input voltage				0.8	V
V_{IK}	Input clamp voltage	$V_{CC} = \text{MIN}, I_I = -12 \text{ mA}$			–1.5	V
V_{OH}	High-level output voltage	$\overline{BI}/\overline{RBO}$ $V_{CC} = \text{MIN}, V_{IH} = 2 \text{ V},$ $V_{IL} = 0.8 \text{ V}, I_{OH} = -200 \mu\text{A}$	2.4	3.7		V
V_{OL}	Low-level output voltage	$\overline{BI}/\overline{RBO}$ $V_{CC} = \text{MIN}, V_{IH} = 2 \text{ V},$ $V_{IL} = 0.8 \text{ V}, I_{OL} = 8 \text{ mA}$		0.27	0.4	V
$I_{O(off)}$	Off-state output current	a thru g $V_{CC} = \text{MAX}, V_{IH} = 2 \text{ V},$ $V_{IL} = 0.8 \text{ V}, V_{O(off)} = \text{MAX}$			250	μ A
$V_{O(on)}$	On-state output voltage	a thru g $V_{CC} = \text{MIN}, V_{IH} = 2 \text{ V},$ $V_{IL} = 0.8 \text{ V}, I_{O(on)} = 40 \text{ mA}$		0.3	0.4	V
I_I	Input current at maximum input voltage	Any input except $\overline{BI}/\overline{RBO}$ $V_{CC} = \text{MAX}, V_I = 5.5 \text{ V}$			1	mA
I_{IH}	High-level input current	Any input except $\overline{BI}/\overline{RBO}$ $V_{CC} = \text{MAX}, V_I = 2.4 \text{ V}$			40	μ A
I_{IL}	Low-level input current	Any input except $\overline{BI}/\overline{RBO}$ $V_{CC} = \text{MAX}, V_I = 0.4 \text{ V}$			–1.6	mA
		$\overline{BI}/\overline{RBO}$			–4	
I_{OS}	Short-circuit output current	$\overline{BI}/\overline{RBO}$ $V_{CC} = \text{MAX}$			–4	mA
I_{CC}	Supply current	$V_{CC} = \text{MAX},$ See Note 2	SN54'	64	85	mA
			SN74'	64	103	

† For conditions shown as MIN or MAX, use the appropriate value specified under recommended operating conditions.

‡ All typical values are at $V_{CC} = 5 \text{ V}, T_A = 25^\circ\text{C}$.

NOTE 2: I_{CC} is measured with all outputs open and all inputs at 4.5 V.

switching characteristics, $V_{CC} = 5 \text{ V}, T_A = 25^\circ\text{C}$

PARAMETER		TEST CONDITIONS	MIN	TYP	MAX	UNIT
t_{off}	Turn-off time from A input	$C_L = 15 \text{ pF}, R_L = 120 \Omega,$ See Note 3			100	ns
t_{on}	Turn-on time from A input				100	
t_{off}	Turn-off time from $\overline{RB1}$ input				100	ns
t_{on}	Turn-on time from $\overline{RB1}$ input				100	

NOTE 3: Load circuits and voltage waveforms are shown in Section 1.



**SN5446A, '47A, '48, SN54LS47, 'LS48, 'LS49
SN7446A, '47A, '48, SN74LS47, 'LS48, 'LS49
BCD-TO-SEVEN-SEGMENT DECODERS/DRIVERS**

SDLS111 – MARCH 1974 – REVISED MARCH 1988

absolute maximum ratings over operating free-air temperature range (unless otherwise noted)

Supply voltage, V_{CC} (see Note 1)	7 V
Input voltage	5.5 V
Operating free-air temperature range: SN5448	-55°C to 125°C
SN7448	0°C to 70°C
Storage temperature range	-65°C to 150°C

NOTE 1: Voltage values are with respect to network ground terminal.

recommended operating conditions

	SN5448			SN7448			UNIT		
	MIN	NOM	MAX	MIN	NOM	MAX			
Supply voltage, V_{CC}	4.5	5	5.5	4.75	5	5.25	V		
High-level output current, I_{OH}	a thru g		-400			-400	μ A		
	$\overline{BI}/\overline{RBO}$		-200			-200			
Low-level output current, I_{OL}	a thru g		6.4			6.4	mA		
	$\overline{BI}/\overline{RBO}$		8			8			
Operating free-air temperature, T_A			-55			125	0	70	°C

electrical characteristics over recommended operating free-air temperature range (unless otherwise noted)

PARAMETER		TEST CONDITIONS†	MIN	TYP‡	MAX	UNIT
V_{IH}	High-level input voltage		2			V
V_{IL}	Low-level input voltage				0.8	V
V_{IK}	Input clamp voltage	$V_{CC} = \text{MIN}, I_I = -12 \text{ mA}$			-1.5	V
V_{OH}	High-level output voltage	a thru g	$V_{CC} = \text{MIN}, V_{IH} = 2 \text{ V},$	2.4	4.2	V
		$\overline{BI}/\overline{RBO}$	$V_{IL} = 0.8 \text{ V}, I_{OH} = \text{MAX}$	2.4	3.7	
I_O	Output current	a thru g	$V_{CC} = \text{MIN}, V_O = 0.85 \text{ V},$	-1.3	-2	mA
			Input conditions as for V_{OH}			
V_{OL}	Low-level output voltage		$V_{CC} = \text{MIN}, V_{IH} = 2 \text{ V},$	0.27	0.4	V
			$V_{IL} = 0.8 \text{ V}, I_{OL} = \text{MAX}$			
I_I	Input current at maximum input voltage	Any input except $\overline{BI}/\overline{RBO}$	$V_{CC} = \text{MAX}, V_I = 5.5 \text{ V}$		1	mA
I_{IH}	High-level input current	Any input except $\overline{BI}/\overline{RBO}$	$V_{CC} = \text{MAX}, V_I = 2.4 \text{ V}$		40	
I_{IL}	Low-level input current	Any input except $\overline{BI}/\overline{RBO}$	$V_{CC} = \text{MAX}, V_I = 0.4 \text{ V}$		-1.6	mA
		$\overline{BI}/\overline{RBO}$			-4	
I_{OS}	Short-circuit output current	$\overline{BI}/\overline{RBO}$	$V_{CC} = \text{MAX}$		-4	mA
I_{CC}	Supply current		$V_{CC} = \text{MAX},$ See Note 2	SN5448	53	
				SN7448	53	90

† For conditions shown as MIN or MAX, use the appropriate value specified under recommended operating conditions.

‡ All typical values are at $V_{CC} = 5 \text{ V}, T_A = 25^\circ\text{C}$.

NOTE 2: I_{CC} is measured with all outputs open and all inputs at 4.5 V.

switching characteristics, $V_{CC} = 5 \text{ V}, T_A = 25^\circ\text{C}$

PARAMETER	TEST CONDITIONS	MIN	TYP	MAX	UNIT
t_{PHL}	$C_L = 15 \text{ pF}, R_L = 1 \text{ k}\Omega$ See Note 3			100	ns
t_{PLH}				100	
t_{PHL}				100	ns
t_{PLH}				100	

NOTE 3: Load circuits and voltage waveforms are shown in Section 1.



SN5446A, '47A, '48, SN54LS47, 'LS48, 'LS49
SN7446A, '47A, '48, SN74LS47, 'LS48, 'LS49
BCD-TO-SEVEN-SEGMENT DECODERS/DRIVERS

SDLS111 – MARCH 1974 – REVISED MARCH 1988

absolute maximum ratings over operating free-air temperature range (unless otherwise noted)

Supply voltage, V_{CC} (see Note 1)	7 V
Input voltage	7 V
Peak output current ($t_w \leq 1$ ms, duty cycle $\leq 10\%$)	200 mA
Current forced into any output in the off state	1 mA
Operating free-air temperature range: SN54LS47	-55°C to 125°C
SN74LS47	0°C to 70°C
Storage temperature range	-65°C to 150°C

NOTE 1: Voltage values are with respect to network ground terminal.

recommended operating conditions

	SN54LS47			SN74LS47			UNIT
	MIN	NOM	MAX	MIN	NOM	MAX	
Supply voltage, V_{CC}	4.5	5	5.5	4.75	5	5.25	V
Off-state output voltage, $V_{O(off)}$	a thru g			15			V
On-state output current, $I_{O(on)}$	a thru g			12			24 mA
High-level output current, I_{OH}	$\overline{BI}/\overline{RB\overline{O}}$			-50			μA
Low-level output current, I_{OL}	$\overline{BI}/\overline{RB\overline{O}}$			1.6			3.2 mA
Operating free-air temperature, T_A	-55	125		0	70		$^\circ\text{C}$

electrical characteristics over recommended operating free-air temperature range (unless otherwise noted)

PARAMETER		TEST CONDITIONS†	SN54LS47		SN74LS47		UNIT
			MIN	TYP‡	MAX	MIN	
V_{IH}	High-level input voltage		2		2		V
V_{IL}	Low-level input voltage		0.7		0.8		V
V_{IK}	Input clamp voltage	$V_{CC} = \text{MIN}, I_I = -18$ mA	-1.5		-1.5		V
V_{OH}	High-level output voltage	$\overline{BI}/\overline{RB\overline{O}}$ $V_{CC} = \text{MIN}, V_{IH} = 2$ V, $V_{IL} = V_{IL \text{ max}}, I_{OH} = -50$ μA	2.4	4.2	2.4	4.2	V
V_{OL}	Low-level output voltage	$\overline{BI}/\overline{RB\overline{O}}$ $V_{CC} = \text{MIN}, V_{IH} = 2$ V, $V_{IL} = V_{IL \text{ max}}$	0.25 0.4		0.25 0.4		V
					0.35 0.5		
$I_{O(off)}$	Off-state output current	a thru g $V_{CC} = \text{MAX}, V_{IH} = 2$ V, $V_{IL} = V_{IL \text{ max}}, V_{O(off)} = 15$ V	250		250		μA
$V_{O(on)}$	On-state output voltage	a thru g $V_{CC} = \text{MIN}, V_{IH} = 2$ V, $V_{IL} = V_{IL \text{ max}}$	0.25 0.4		0.25 0.4		V
					0.35 0.5		
I_I	Input current at maximum input voltage	$V_{CC} = \text{MAX}, V_I = 7$ V	0.1		0.1		mA
I_{IH}	High-level input current	$V_{CC} = \text{MAX}, V_I = 2.7$ V	20		20		μA
I_{IL}	Low-level input current	$V_{CC} = \text{MAX}, V_I = 0.4$ V	-0.4		-0.4		mA
	Any input except $\overline{BI}/\overline{RB\overline{O}}$		-1.2		-1.2		
I_{OS}	Short-circuit output current	$\overline{BI}/\overline{RB\overline{O}}$ $V_{CC} = \text{MAX}$	-0.3	-2	-0.3	-2	mA
I_{CC}	Supply current	$V_{CC} = \text{MAX},$ See Note 2	7	13	7	13	mA

†For conditions shown as MIN or MAX, use the appropriate value specified under recommended operating conditions.

‡All typical values are at $V_{CC} = 5$ V, $T_A = 25^\circ\text{C}$.

NOTE 2: I_{CC} is measured with all outputs open and all inputs at 4.5 V.

switching characteristics, $V_{CC} = 5$ V, $T_A = 25^\circ\text{C}$

PARAMETER		TEST CONDITIONS	MIN	TYP	MAX	UNIT
t_{off}	Turn-off time from A input	$C_L = 15$ pF, $R_L = 665$ Ω , See Note 3	100			ns
t_{on}	Turn-on time from A input		100			
t_{off}	Turn-off time from $\overline{RB\overline{I}}$ input, outputs (a-f) only		100			ns
t_{on}	Turn-on time from $\overline{RB\overline{I}}$ input, outputs (a-f) only		100			

NOTE 3: Load circuits and voltage waveforms are shown in Section 1.



**SN5446A, '47A, '48, SN54LS47, 'LS48, 'LS49
SN7446A, '47A, '48, SN74LS47, 'LS48, 'LS49
BCD-TO-SEVEN-SEGMENT DECODERS/DRIVERS**

SDLS111 – MARCH 1974 – REVISED MARCH 1988

absolute maximum ratings over operating free-air temperature range (unless otherwise noted)

Supply voltage, V_{CC} (see Note 1)	7 V
Input voltage	7 V
Operating free-air temperature range: SN54LS48	-55°C to 125°C
SN74LS48	0°C to 70°C
Storage temperature range	-65°C to 150°C

NOTE 1: Voltage values are with respect to network ground terminal.

recommended operating conditions

	SN54LS48			SN74LS48			UNIT
	MIN	NOM	MAX	MIN	NOM	MAX	
Supply voltage, V_{CC}	4.5	5	5.5	4.75	5	5.25	V
High-level output current, I_{OH}	a thru g		-100			-100	μ A
	$\overline{BI}/\overline{RBO}$		-50			-50	
Low-level output current, I_{OL}	a thru g		2			6	mA
	$\overline{BI}/\overline{RBO}$		1.6			3.2	
Operating free-air temperature, T_A	-55		125	0		70	°C

electrical characteristics over recommended operating free-air temperature range (unless otherwise noted)

PARAMETER		TEST CONDITIONS†	SN54LS48			SN74LS48			UNIT
			MIN	TYP‡	MAX	MIN	TYP‡	MAX	
V_{IH}	High-level input voltage		2			2			V
V_{IL}	Low-level input voltage				0.7			0.8	V
V_{IK}	Input clamp voltage	$V_{CC} = \text{MIN}, I_I = -18 \text{ mA}$			-1.5			-1.5	V
V_{OH}	High-level output voltage	a thru g and $\overline{BI}/\overline{RBO}$ $V_{CC} = \text{MIN}, V_{IH} = 2 \text{ V}, V_{IL} = V_{IL \text{ max}}, I_{OH} = \text{MAX}$	2.4	4.2		2.4	4.2		V
I_O	Output current	a thru g $V_{CC} = \text{MIN}, V_O = 0.85 \text{ V},$ Input conditions as for V_{OH}	-1.3	-2		-1.3	-2		mA
V_{OL}	Low-level output voltage	a thru g $V_{CC} = \text{MIN}, V_{IH} = 2 \text{ V}, V_{IL} = V_{IL \text{ max}}$	$I_{OL} = 2 \text{ mA}$		0.25	0.4	0.25	0.4	V
			$I_{OL} = 6 \text{ mA}$				0.35	0.5	
	$\overline{BI}/\overline{RBO}$	$V_{CC} = \text{MIN}, V_{IH} = 2 \text{ V}, V_{IL} = V_{IL \text{ max}}$	$I_{OL} = 1.6 \text{ mA}$		0.25	0.4	0.25	0.4	V
			$I_{OL} = 3.2 \text{ mA}$				0.35	0.5	
I_I	Input current at maximum input voltage	Any input except $\overline{BI}/\overline{RBO}$ $V_{CC} = \text{MAX}, V_I = 7 \text{ V}$			0.1		0.1		mA
I_{IH}	High-level input current	Any input except $\overline{BI}/\overline{RBO}$ $V_{CC} = \text{MAX}, V_I = 2.7 \text{ V}$			20		20		μ A
I_{IL}	Low-level input current	Any input except $\overline{BI}/\overline{RBO}$ $V_{CC} = \text{MAX}, V_I = 0.4 \text{ V}$			-0.4		-0.4		mA
		$\overline{BI}/\overline{RBO}$			-1.2		-1.2		
I_{OS}	Short-circuit output current	$\overline{BI}/\overline{RBO}$ $V_{CC} = \text{MAX}$	-0.3		-2	-0.3		-2	mA
I_{CC}	Supply current	$V_{CC} = \text{MAX},$ See Note 2		25	38		25	38	mA

†For conditions shown as MIN or MAX, use the appropriate value specified under recommended operating conditions.

‡All typical values are at $V_{CC} = 5 \text{ V}, T_A = 25^\circ \text{C}.$

NOTE 2: I_{CC} is measured with all outputs open and all inputs at 4.5 V.

switching characteristics, $V_{CC} = 5 \text{ V}, T_A = 25^\circ \text{C}$

PARAMETER	TEST CONDITIONS	MIN	TYP	MAX	UNIT
t_{PHL} Propagation delay time, high-to-low-level output from A input	$C_L = 15 \text{ pF}, R_L = 4 \text{ k}\Omega,$			100	ns
t_{PLH} Propagation delay time, low-to-high-level output from A input	See Note 3			100	
t_{PHL} Propagation delay time, high-to-low-level output (a-f only) from \overline{RBI} input	$C_L = 15 \text{ pF}, R_L = 6 \text{ k}\Omega,$			100	ns
t_{PLH} Propagation delay time, low-to-high-level output (a-f only) from \overline{RBI} input	See Note 3			100	

NOTE 3: Load circuits and voltage waveforms are shown in Section 1.



SN5446A, '47A, '48, SN54LS47, 'LS48, 'LS49
SN7446A, '47A, '48, SN74LS47, 'LS48, 'LS49
BCD-TO-SEVEN-SEGMENT DECODERS/DRIVERS

SDLS111 – MARCH 1974 – REVISED MARCH 1988

absolute maximum ratings over operating free-air temperature range (unless otherwise noted)

Supply voltage, V_{CC} (see Note 1)	7	V
Input voltage	7	V
Current forced into any output in the off state	1	mA
Operating free-air temperature range: SN54LS49	-55	°C to 125
SN74LS49	0	°C to 70
Storage temperature range	-65	°C to 150

NOTE 1: Voltage values are with respect to network ground terminal.

recommended operating conditions

	SN54LS49			SN74LS49			UNIT
	MIN	NOM	MAX	MIN	NOM	MAX	
Supply voltage, V_{CC}	4.5	5	5.5	4.75	5	5.25	V
High-level output voltage, V_{OH}			5.5			5.5	V
Low-level output current, I_{OL}			4			β	mA
Operating free-air temperature, T_A	-55		125	0		70	°C

electrical characteristics over recommended operating free-air temperature range (unless otherwise noted)

PARAMETER	TEST CONDITIONS†	SN54LS49			SN74LS49			UNIT
		MIN	TYP‡	MAX	MIN	TYP‡	MAX	
V_{IH} High-level input voltage		2			2			V
V_{IL} Low-level input voltage				0.7			0.8	V
V_{IK} Input clamp voltage	$V_{CC} = \text{MIN}, I_I = -18 \text{ mA}$			-1.5			-1.5	V
I_{OH} High-level output current	$V_{CC} = \text{MIN}, V_{IH} = 2 \text{ V}, V_{IL} = V_{IL \text{ max}}, V_{OH} = 5.5 \text{ V}$			250			250	μA
V_{OL} Low-level output voltage	$V_{CC} = \text{MIN}, V_{IH} = 2 \text{ V}, V_{IL} = V_{IL \text{ max}}$	$I_{OL} = 4 \text{ mA}$		0.25	0.4	0.25	0.4	V
		$I_{OL} = 8 \text{ mA}$				0.35	0.5	
I_I Input current at maximum input voltage	$V_{CC} = \text{MAX}, V_I = 7 \text{ V}$			0.1			0.1	mA
I_{IH} High-level input current	$V_{CC} = \text{MAX}, V_I = 2.7 \text{ V}$			20			20	μA
I_{IL} Low-level input current	$V_{CC} = \text{MAX}, V_I = 0.4 \text{ V}$			-0.4			-0.4	mA
I_{CC} Supply current	$V_{CC} = \text{MAX}, \text{ See Note 2}$	8	15		8	15		mA

†For conditions shown as MIN or MAX, use the appropriate value specified under recommended operating conditions.

‡All typical values are at $V_{CC} = 5 \text{ V}, T_A = 25^\circ\text{C}$.

NOTE 2: I_{CC} is measured with all outputs open and all inputs at 4.5 V.

switching characteristics, $V_{CC} = 5 \text{ V}, T_A = 25^\circ\text{C}$

PARAMETER	TEST CONDITIONS	MIN	TYP	MAX	UNIT
t_{PHL} Propagation delay time, high-to-low-level output from A input	$C_L = 15 \text{ pF}, R_L = 4 \text{ k}\Omega$			100	ns
t_{PLH} Propagation delay time, low-to-high-level output from A input	See Note 3			100	
t_{PHL} Propagation delay time, high-to-low-level output (a-f only) from RBI input	$C_L = 15 \text{ pF}, R_L = 6 \text{ k}\Omega$			100	ns
t_{PLH} Propagation delay time, low-to-high-level output (a-f only) from RBI input	See Note 3			100	

NOTE 3: Load circuits and voltage waveforms are shown in Section 1.



PACKAGING INFORMATION

Orderable Device	Status (1)	Package Type	Package Drawing	Pins	Package Qty	Eco Plan (2)	Lead finish/ Ball material (6)	MSL Peak Temp (3)	Op Temp (°C)	Device Marking (4/5)	Samples
5962-9856401QEA	ACTIVE	CDIP	J	16	1	Non-RoHS & Green	SNPB	N / A for Pkg Type	-55 to 125	5962-9856401QE A SNJ5447AJ	Samples
5962-9856401QFA	ACTIVE	CFP	W	16	1	Non-RoHS & Green	SNPB	N / A for Pkg Type	-55 to 125	5962-9856401QF A SNJ5447AW	Samples
7604501EA	ACTIVE	CDIP	J	16	1	Non-RoHS & Green	SNPB	N / A for Pkg Type	-55 to 125	7604501EA SNJ54LS47J	Samples
SN5447AJ	ACTIVE	CDIP	J	16	1	Non-RoHS & Green	SNPB	N / A for Pkg Type	-55 to 125	SN5447AJ	Samples
SN54LS47J	ACTIVE	CDIP	J	16	1	Non-RoHS & Green	SNPB	N / A for Pkg Type	-55 to 125	SN54LS47J	Samples
SN54LS49J	ACTIVE	CDIP	J	14	1	Non-RoHS & Green	SNPB	N / A for Pkg Type	-55 to 125	SN54LS49J	Samples
SN7447AN	ACTIVE	PDIP	N	16	25	RoHS & Green	NIPDAU	N / A for Pkg Type	0 to 70	SN7447AN	Samples
SN7447ANE4	ACTIVE	PDIP	N	16	25	RoHS & Green	NIPDAU	N / A for Pkg Type	0 to 70	SN7447AN	Samples
SN74LS47D	ACTIVE	SOIC	D	16	40	RoHS & Green	NIPDAU	Level-1-260C-UNLIM	0 to 70	LS47	Samples
SN74LS47DG4	ACTIVE	SOIC	D	16	40	RoHS & Green	NIPDAU	Level-1-260C-UNLIM	0 to 70	LS47	Samples
SN74LS47DR	ACTIVE	SOIC	D	16	2500	RoHS & Green	NIPDAU	Level-1-260C-UNLIM		LS47	Samples
SN74LS47N	ACTIVE	PDIP	N	16	25	RoHS & Green	NIPDAU	N / A for Pkg Type	0 to 70	SN74LS47N	Samples
SN74LS47NE4	ACTIVE	PDIP	N	16	25	RoHS & Green	NIPDAU	N / A for Pkg Type	0 to 70	SN74LS47N	Samples
SN74LS47NSR	ACTIVE	SO	NS	16	2000	RoHS & Green	NIPDAU	Level-1-260C-UNLIM	0 to 70	74LS47	Samples
SNJ5447AJ	ACTIVE	CDIP	J	16	1	Non-RoHS & Green	SNPB	N / A for Pkg Type	-55 to 125	5962-9856401QE A SNJ5447AJ	Samples
SNJ5447AW	ACTIVE	CFP	W	16	1	Non-RoHS & Green	SNPB	N / A for Pkg Type	-55 to 125	5962-9856401QF A SNJ5447AW	Samples

Orderable Device	Status (1)	Package Type	Package Drawing	Pins	Package Qty	Eco Plan (2)	Lead finish/ Ball material (6)	MSL Peak Temp (3)	Op Temp (°C)	Device Marking (4/5)	Samples
SNJ54LS47FK	ACTIVE	LCCC	FK	20	1	Non-RoHS & Green	SNPB	N / A for Pkg Type	-55 to 125	SNJ54LS 47FK	Samples
SNJ54LS47J	ACTIVE	CDIP	J	16	1	Non-RoHS & Green	SNPB	N / A for Pkg Type	-55 to 125	7604501EA SNJ54LS47J	Samples
SNJ54LS49J	ACTIVE	CDIP	J	14	1	Non-RoHS & Green	SNPB	N / A for Pkg Type	-55 to 125	SNJ54LS49J	Samples

(1) The marketing status values are defined as follows:

ACTIVE: Product device recommended for new designs.

LIFEBUY: TI has announced that the device will be discontinued, and a lifetime-buy period is in effect.

NRND: Not recommended for new designs. Device is in production to support existing customers, but TI does not recommend using this part in a new design.

PREVIEW: Device has been announced but is not in production. Samples may or may not be available.

OBSOLETE: TI has discontinued the production of the device.

(2) **RoHS:** TI defines "RoHS" to mean semiconductor products that are compliant with the current EU RoHS requirements for all 10 RoHS substances, including the requirement that RoHS substance do not exceed 0.1% by weight in homogeneous materials. Where designed to be soldered at high temperatures, "RoHS" products are suitable for use in specified lead-free processes. TI may reference these types of products as "Pb-Free".

RoHS Exempt: TI defines "RoHS Exempt" to mean products that contain lead but are compliant with EU RoHS pursuant to a specific EU RoHS exemption.

Green: TI defines "Green" to mean the content of Chlorine (Cl) and Bromine (Br) based flame retardants meet JS709B low halogen requirements of <=1000ppm threshold. Antimony trioxide based flame retardants must also meet the <=1000ppm threshold requirement.

(3) MSL, Peak Temp. - The Moisture Sensitivity Level rating according to the JEDEC industry standard classifications, and peak solder temperature.

(4) There may be additional marking, which relates to the logo, the lot trace code information, or the environmental category on the device.

(5) Multiple Device Markings will be inside parentheses. Only one Device Marking contained in parentheses and separated by a "-" will appear on a device. If a line is indented then it is a continuation of the previous line and the two combined represent the entire Device Marking for that device.

(6) Lead finish/Ball material - Orderable Devices may have multiple material finish options. Finish options are separated by a vertical ruled line. Lead finish/Ball material values may wrap to two lines if the finish value exceeds the maximum column width.

Important Information and Disclaimer:The information provided on this page represents TI's knowledge and belief as of the date that it is provided. TI bases its knowledge and belief on information provided by third parties, and makes no representation or warranty as to the accuracy of such information. Efforts are underway to better integrate information from third parties. TI has taken and continues to take reasonable steps to provide representative and accurate information but may not have conducted destructive testing or chemical analysis on incoming materials and chemicals. TI and TI suppliers consider certain information to be proprietary, and thus CAS numbers and other limited information may not be available for release.

In no event shall TI's liability arising out of such information exceed the total purchase price of the TI part(s) at issue in this document sold by TI to Customer on an annual basis.

OTHER QUALIFIED VERSIONS OF SN5447A, SN54LS47, SN7447A, SN74LS47 :

- Catalog : [SN7447A](#), [SN74LS47](#)
- Military : [SN5447A](#), [SN54LS47](#)

NOTE: Qualified Version Definitions:

- Catalog - TI's standard catalog product
- Military - QML certified for Military and Defense Applications

TAPE AND REEL INFORMATION

QUADRANT ASSIGNMENTS FOR PIN 1 ORIENTATION IN TAPE



*All dimensions are nominal

Device	Package Type	Package Drawing	Pins	SPQ	Reel Diameter (mm)	Reel Width W1 (mm)	A0 (mm)	B0 (mm)	K0 (mm)	P1 (mm)	W (mm)	Pin1 Quadrant
SN74LS47DR	SOIC	D	16	2500	330.0	16.4	6.5	10.3	2.1	8.0	16.0	Q1
SN74LS47NSR	SO	NS	16	2000	330.0	16.4	8.2	10.5	2.5	12.0	16.0	Q1

TAPE AND REEL BOX DIMENSIONS

*All dimensions are nominal

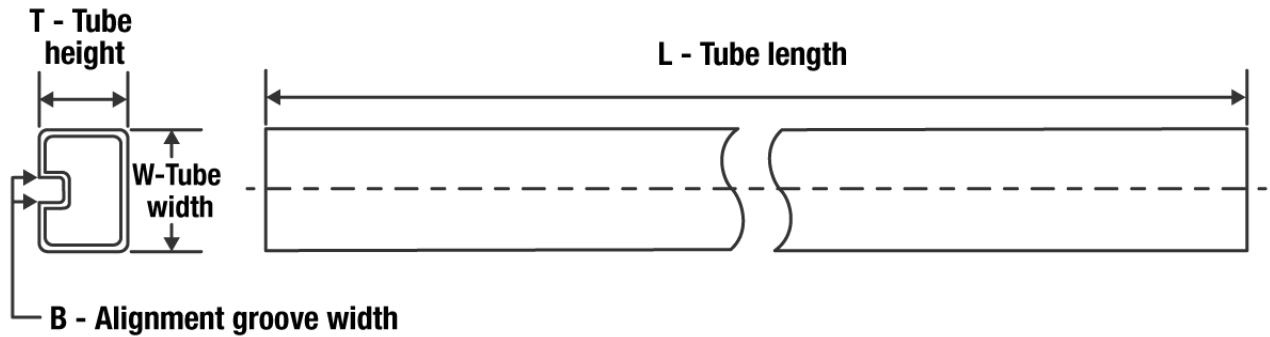
Device	Package Type	Package Drawing	Pins	SPQ	Length (mm)	Width (mm)	Height (mm)
SN74LS47DR	SOIC	D	16	2500	340.5	336.1	32.0
SN74LS47NSR	SO	NS	16	2000	853.0	449.0	35.0

TUBE

*All dimensions are nominal

Device	Package Name	Package Type	Pins	SPQ	L (mm)	W (mm)	T (μm)	B (mm)
SN7447AN	N	PDIP	16	25	506	13.97	11230	4.32
SN7447AN	N	PDIP	16	25	506	13.97	11230	4.32
SN7447ANE4	N	PDIP	16	25	506	13.97	11230	4.32
SN7447ANE4	N	PDIP	16	25	506	13.97	11230	4.32
SN74LS47D	D	SOIC	16	40	507	8	3940	4.32
SN74LS47DG4	D	SOIC	16	40	507	8	3940	4.32
SN74LS47N	N	PDIP	16	25	506	13.97	11230	4.32
SN74LS47N	N	PDIP	16	25	506	13.97	11230	4.32
SN74LS47NE4	N	PDIP	16	25	506	13.97	11230	4.32
SN74LS47NE4	N	PDIP	16	25	506	13.97	11230	4.32
SNJ54LS47FK	FK	LCCC	20	1	506.98	12.06	2030	NA



PACKAGE OUTLINE

NS0016A

SOP - 2.00 mm max height

SOP



4220735/A 12/2021

NOTES:

1. All linear dimensions are in millimeters. Dimensions in parenthesis are for reference only. Dimensioning and tolerancing per ASME Y14.5M.
2. This drawing is subject to change without notice.
3. This dimension does not include mold flash, protrusions, or gate burrs. Mold flash, protrusions, or gate burrs shall not exceed 0.15 mm, per side.
4. This dimension does not include interlead flash. Interlead flash shall not exceed 0.25 mm, per side.

EXAMPLE BOARD LAYOUT

NS0016A

SOP - 2.00 mm max height

SOP



4220735/A 12/2021

NOTES: (continued)

5. Publication IPC-7351 may have alternate designs.

6. Solder mask tolerances between and around signal pads can vary based on board fabrication site.

EXAMPLE STENCIL DESIGN

NS0016A

SOP - 2.00 mm max height

SOP



SOLDER PASTE EXAMPLE
BASED ON 0.125 mm THICK STENCIL
SCALE:7X

4220735/A 12/2021

NOTES: (continued)

7. Laser cutting apertures with trapezoidal walls and rounded corners may offer better paste release. IPC-7525 may have alternate design recommendations.
8. Board assembly site may have different recommendations for stencil design.

FK (S-CQCC-N**)

LEADLESS CERAMIC CHIP CARRIER

28 TERMINAL SHOWN



NO. OF TERMINALS **	A		B	
	MIN	MAX	MIN	MAX
20	0.342 (8,69)	0.358 (9,09)	0.307 (7,80)	0.358 (9,09)
28	0.442 (11,23)	0.458 (11,63)	0.406 (10,31)	0.458 (11,63)
44	0.640 (16,26)	0.660 (16,76)	0.495 (12,58)	0.560 (14,22)
52	0.740 (18,78)	0.761 (19,32)	0.495 (12,58)	0.560 (14,22)
68	0.938 (23,83)	0.962 (24,43)	0.850 (21,6)	0.858 (21,8)
84	1.141 (28,99)	1.165 (29,59)	1.047 (26,6)	1.063 (27,0)



4040140/D 01/11

- NOTES:
- All linear dimensions are in inches (millimeters).
 - This drawing is subject to change without notice.
 - This package can be hermetically sealed with a metal lid.
 - Falls within JEDEC MS-004

D (R-PDSO-G16)

PLASTIC SMALL OUTLINE



4040047-6/M 06/11

- NOTES:
- A. All linear dimensions are in inches (millimeters).
 - B. This drawing is subject to change without notice.
 -  C. Body length does not include mold flash, protrusions, or gate burrs. Mold flash, protrusions, or gate burrs shall not exceed 0.006 (0,15) each side.
 -  D. Body width does not include interlead flash. Interlead flash shall not exceed 0.017 (0,43) each side.
 - E. Reference JEDEC MS-012 variation AC.

D (R-PDSO-G16)

PLASTIC SMALL OUTLINE



- NOTES:
- A. All linear dimensions are in millimeters.
 - B. This drawing is subject to change without notice.
 - C. Publication IPC-7351 is recommended for alternate designs.
 - D. Laser cutting apertures with trapezoidal walls and also rounding corners will offer better paste release. Customers should contact their board assembly site for stencil design recommendations. Refer to IPC-7525 for other stencil recommendations.
 - E. Customers should contact their board fabrication site for solder mask tolerances between and around signal pads.

MECHANICAL DATA

NS (R-PDSO-G**)

PLASTIC SMALL-OUTLINE PACKAGE

14-PINS SHOWN



- NOTES:
- A. All linear dimensions are in millimeters.
 - B. This drawing is subject to change without notice.
 - C. Body dimensions do not include mold flash or protrusion, not to exceed 0,15.

W (R-GDFP-F16)

CERAMIC DUAL FLATPACK

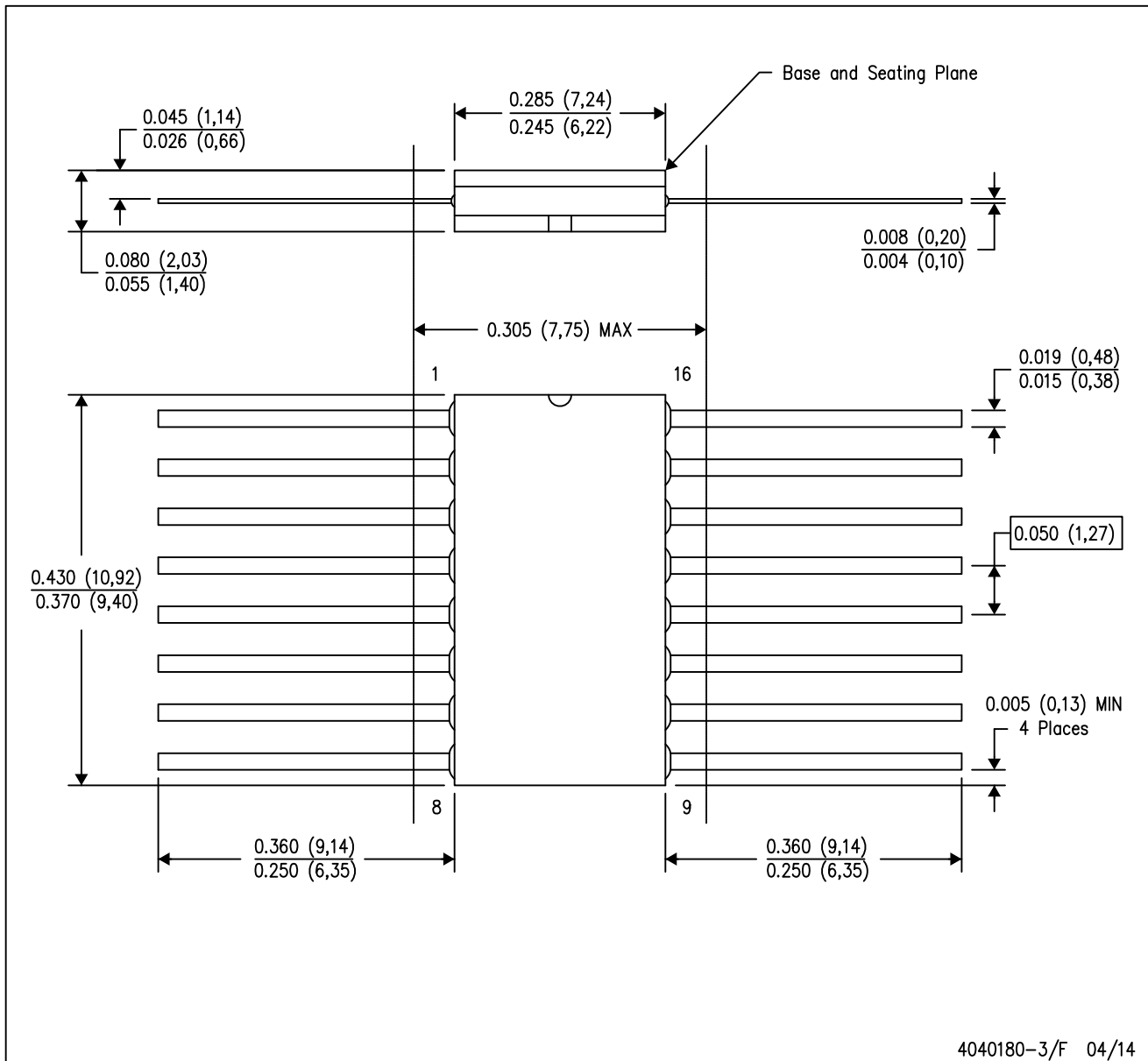

- NOTES:
- A. All linear dimensions are in inches (millimeters).
 - B. This drawing is subject to change without notice.
 - C. This package can be hermetically sealed with a ceramic lid using glass frit.
 - D. Index point is provided on cap for terminal identification only.
 - E. Falls within MIL STD 1835 GDFP2-F16

J (R-GDIP-T**)

14 LEADS SHOWN

CERAMIC DUAL IN-LINE PACKAGE



DIM \ PINS **	14	16	18	20
A	0.300 (7,62) BSC	0.300 (7,62) BSC	0.300 (7,62) BSC	0.300 (7,62) BSC
B MAX	0.785 (19,94)	.840 (21,34)	0.960 (24,38)	1.060 (26,92)
B MIN	—	—	—	—
C MAX	0.300 (7,62)	0.300 (7,62)	0.310 (7,87)	0.300 (7,62)
C MIN	0.245 (6,22)	0.245 (6,22)	0.220 (5,59)	0.245 (6,22)



4040083/F 03/03

- NOTES:
- All linear dimensions are in inches (millimeters).
 - This drawing is subject to change without notice.
 - This package is hermetically sealed with a ceramic lid using glass frit.
 - Index point is provided on cap for terminal identification only on press ceramic glass frit seal only.
 - Falls within MIL STD 1835 GDIP1-T14, GDIP1-T16, GDIP1-T18 and GDIP1-T20.

J 14

GENERIC PACKAGE VIEW
CDIP - 5.08 mm max height
CERAMIC DUAL IN LINE PACKAGE

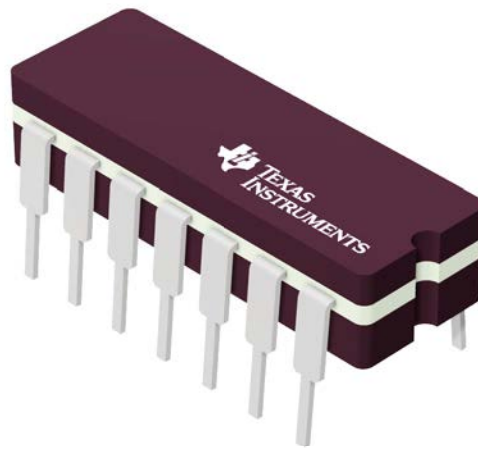

Images above are just a representation of the package family, actual package may vary.
Refer to the product data sheet for package details.

4040083-5/G

J0014A

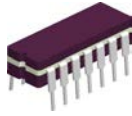

PACKAGE OUTLINE

CDIP - 5.08 mm max height

CERAMIC DUAL IN LINE PACKAGE



4214771/A 05/2017

NOTES:

1. All controlling linear dimensions are in inches. Dimensions in brackets are in millimeters. Any dimension in brackets or parenthesis are for reference only. Dimensioning and tolerancing per ASME Y14.5M.
2. This drawing is subject to change without notice.
3. This package is hermetically sealed with a ceramic lid using glass frit.
4. Index point is provided on cap for terminal identification only and on press ceramic glass frit seal only.
5. Falls within MIL-STD-1835 and GDIP1-T14.

EXAMPLE BOARD LAYOUT

J0014A

CDIP - 5.08 mm max height

CERAMIC DUAL IN LINE PACKAGE



LAND PATTERN EXAMPLE
NON-SOLDER MASK DEFINED
SCALE: 5X

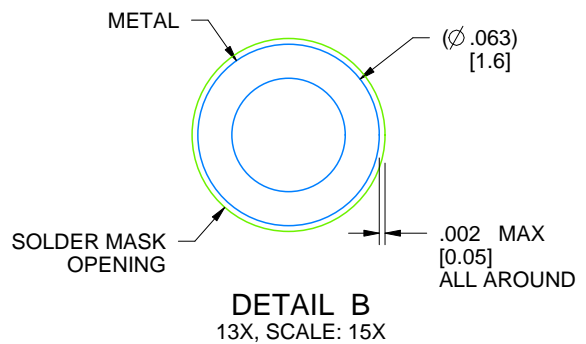

4214771/A 05/2017

N (R-PDIP-T**)

PLASTIC DUAL-IN-LINE PACKAGE

16 PINS SHOWN



- NOTES:
- A. All linear dimensions are in inches (millimeters).
 - B. This drawing is subject to change without notice.
 - Falls within JEDEC MS-001, except 18 and 20 pin minimum body length (Dim A).
 - The 20 pin end lead shoulder width is a vendor option, either half or full width.

IMPORTANT NOTICE AND DISCLAIMER

TI PROVIDES TECHNICAL AND RELIABILITY DATA (INCLUDING DATA SHEETS), DESIGN RESOURCES (INCLUDING REFERENCE DESIGNS), APPLICATION OR OTHER DESIGN ADVICE, WEB TOOLS, SAFETY INFORMATION, AND OTHER RESOURCES "AS IS" AND WITH ALL FAULTS, AND DISCLAIMS ALL WARRANTIES, EXPRESS AND IMPLIED, INCLUDING WITHOUT LIMITATION ANY IMPLIED WARRANTIES OF MERCHANTABILITY, FITNESS FOR A PARTICULAR PURPOSE OR NON-INFRINGEMENT OF THIRD PARTY INTELLECTUAL PROPERTY RIGHTS.

These resources are intended for skilled developers designing with TI products. You are solely responsible for (1) selecting the appropriate TI products for your application, (2) designing, validating and testing your application, and (3) ensuring your application meets applicable standards, and any other safety, security, regulatory or other requirements.

These resources are subject to change without notice. TI grants you permission to use these resources only for development of an application that uses the TI products described in the resource. Other reproduction and display of these resources is prohibited. No license is granted to any other TI intellectual property right or to any third party intellectual property right. TI disclaims responsibility for, and you will fully indemnify TI and its representatives against, any claims, damages, costs, losses, and liabilities arising out of your use of these resources.

TI's products are provided subject to [TI's Terms of Sale](#) or other applicable terms available either on ti.com or provided in conjunction with such TI products. TI's provision of these resources does not expand or otherwise alter TI's applicable warranties or warranty disclaimers for TI products.

TI objects to and rejects any additional or different terms you may have proposed.

Mailing Address: Texas Instruments, Post Office Box 655303, Dallas, Texas 75265
Copyright © 2022, Texas Instruments Incorporated