

SN75124 TRIPLE LINE RECEIVER

SLLS058B – SEPTEMBER 1973 – REVISED MAY 1995

- Meets or Exceeds the Requirements of IBM™ System 360 Input/Output Interface Specification
- Operates From Single 5-V Supply
- TTL Compatible
- Built-In Input Threshold Hysteresis
- High Speed . . . Typical Propagation Delay Time = 20 ns
- Independent Channel Strobes
- Input Gating Increases Application Flexibility
- Designed for Use With Dual Line Driver SN75123
- Designed to Be Interchangeable With Signetics N8T24

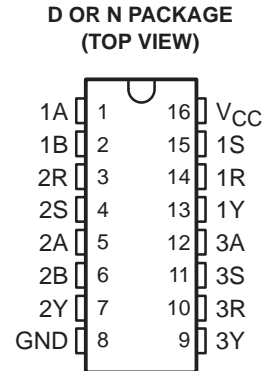

description

The SN75124 triple line receiver is specifically designed to meet the input/output interface specifications for IBM System 360. It is also compatible with standard TTL logic and supply voltage levels.

The SN75124 has receiver inputs with built-in hysteresis to provide increased noise margin for single-ended systems. An open line affects the receiver input as does a low-level input voltage, and the receiver input can withstand a level of -0.15 V with power on or off. The other inputs are in TTL configuration. The S input must be high to enable the receiver input. Two of the line receivers have A and B inputs that, if both are high, hold the output low. The third receiver has only an A input that, if high, holds the output low.

See the SN751730 for new IBM 360/370 interface designs.

The SN75124 is characterized for operation from 0°C to 70°C .

FUNCTION TABLE

INPUTS				OUTPUT Y
A	B†	R	S	
H	H	X	X	L
X	X	L	H	L
L	X	H	X	H
L	X	X	L	H
X	L	H	X	H
X	L	X	L	H

† B input and last two lines of the function table are applicable to receivers 1 and 2 only.



Please be aware that an important notice concerning availability, standard warranty, and use in critical applications of Texas Instruments semiconductor products and disclaimers thereto appears at the end of this data sheet.

IBM is a trademark of International Business Machines Corp.

PRODUCTION DATA information is current as of publication date. Products conform to specifications per the terms of Texas Instruments standard warranty. Production processing does not necessarily include testing of all parameters.

 **TEXAS
INSTRUMENTS**

POST OFFICE BOX 655303 • DALLAS, TEXAS 75265

Copyright © 1995, Texas Instruments Incorporated

SN75124 TRIPLE LINE RECEIVER

SLLS058B – SEPTEMBER 1973 – REVISED MAY 1995

logic symbol†

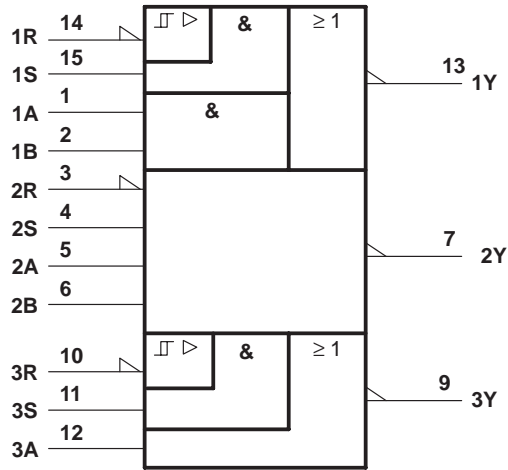

† This symbol is in accordance with ANSI/IEEE Std 91-1984 and IEC Publication 617-12.

logic diagram (positive logic)

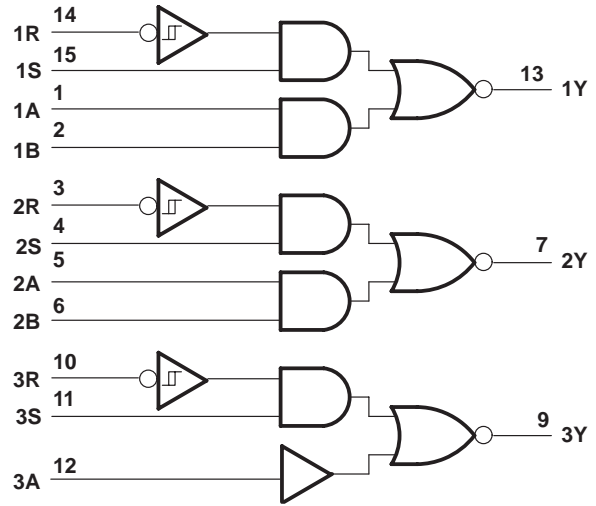

schematic (each receiver)

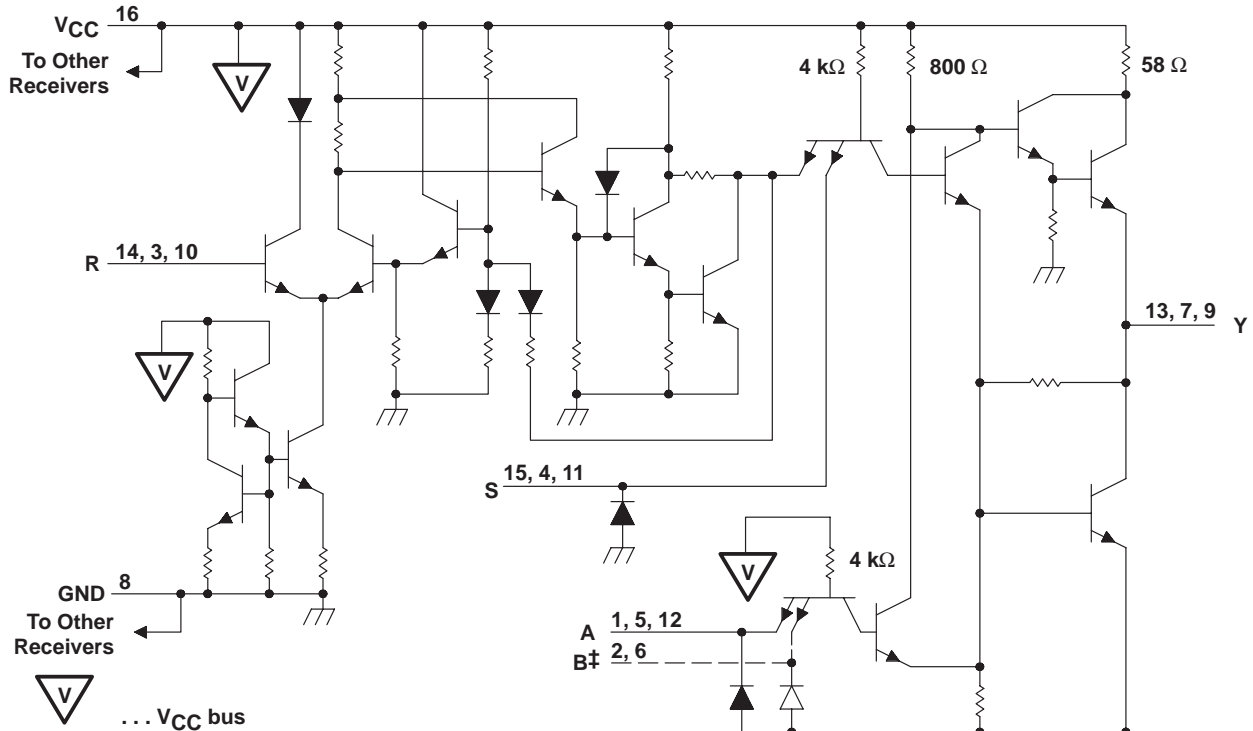

‡ B input is provided on receivers 1 and 2 only
Resistor values shown are nominal.

absolute maximum ratings over operating free-air temperature range (unless otherwise noted)†

Supply voltage, V_{CC} (see Note 1)	7 V
Input voltage, V_I : R input with V_{CC} applied	7 V
R input with V_{CC} not applied	6 V
A, B, or S input	5.5 V
Output voltage, V_O	7 V
Output current, I_O	± 100 mA
Continuous total dissipation	See Dissipation Rating Table
Operating free-air temperature range, T_A	0°C to 70°C
Storage temperature range, T_{stg}	-65°C to 150°C
Lead temperature 1,6 mm (1/16 inch) from case for 10 seconds	260°C

† Stresses beyond those listed under “absolute maximum ratings” may cause permanent damage to the device. These are stress ratings only, and functional operation of the device at these or any other conditions beyond those indicated under “recommended operating conditions” is not implied. Exposure to absolute-maximum-rated conditions for extended periods may affect device reliability.

NOTE 1: Voltage values are with respect to network ground terminal

DISSIPATION RATING TABLE

PACKAGE	$T_A \leq 25^\circ\text{C}$ POWER RATING	DERATING FACTOR ABOVE $T_A = 25^\circ\text{C}$	$T_A = 70^\circ\text{C}$ POWER RATING
D	950 mW	7.6 mW/ $^\circ\text{C}$	608 mW
N	1150 mW	9.2 mW/ $^\circ\text{C}$	736 mW

recommended operating conditions

		MIN	NOM	MAX	UNIT
Supply voltage, V_{CC}		4.75	5	5.25	V
High-level input voltage, V_{IH}	A, B, or S	2			V
	R	1.7			
Low-level input voltage, V_{IL}	A, B, or S	0.8			V
	R	0.7			
High-level output current, I_{OH}		-800			μA
Low-level output current, I_{OL}		16			mA
Operating free-air temperature, T_A		0	70		$^\circ\text{C}$

SN75124 TRIPLE LINE RECEIVER

SLLS058B – SEPTEMBER 1973 – REVISED MAY 1995

electrical characteristics over recommended ranges of supply voltage and operating free-air temperature (unless otherwise noted)

PARAMETER			TEST CONDITIONS		MIN	TYP	MAX	UNIT
V_{hys}	Hysteresis voltage ($V_{IT+} - V_{IT-}$)	R	$V_{CC} = 5\text{ V}$,	$T_A = 25^\circ\text{C}$	0.2	0.5		V
V_{IK}	Input clamp voltage	A, B, or S	$V_{CC} = 5\text{ V}$,	$I_I = 12\text{ mA}$			-1.5	V
$V_{I(BR)}$	Input breakdown voltage	A, B, or S	$V_{CC} = 5\text{ V}$,	$I_I = 10\text{ mA}$	5.5			V
V_{OH}	High-level output voltage		$V_{IH} = V_{IHmin}$, $I_{OH} = -800\ \mu\text{A}$,	$V_{IL} = V_{ILmax}$, See Note 2	2.6			V
V_{OL}	Low-level output voltage		$V_{IH} = V_{IHmin}$, $I_{OL} = 16\text{ mA}$,	$V_{IL} = V_{ILmax}$, See Note 2			0.4	V
I_I	Input current at maximum input voltage	R	$V_I = 7\text{ V}$				5	mA
			$V_I = 6\text{ V}$,	$V_{CC} = 0$			5	
I_{IH}	High-level input current	A, B, or S	$V_I = 4.5\text{ V}$				40	μA
		R	$V_I = 3.11\text{ V}$				170	
I_{IL}	Low-level input current	A, B, or S	$V_I = 0.4\text{ V}$,	$V_{IR} = 0.8\text{ V}$	-0.1		-1.6	mA
I_{OS}	Short-circuit output current†				-50		-100	mA
I_{CC}	Supply current		All inputs = 0.8 V				72	mA
			All inputs = 2 V				100	

† Not more than one output should be shorted at a time, and duration of the short circuit should not exceed one second.

NOTE 2: The output voltage and current limits are characterized for any appropriate combination of high and low inputs specified by the function table for the desired output.

switching characteristics, $V_{CC} = 5\text{ V}$, $T_A = 25^\circ\text{C}$

PARAMETER			TEST CONDITIONS		MIN	TYP	MAX	UNIT
t_{PLH}	Propagation delay time, low-to-high-level output from R input		See Figure 1			20	30	ns
t_{PHL}	Propagation delay time, high-to-low-level output from R input					20	30	

PARAMETER MEASUREMENT INFORMATION

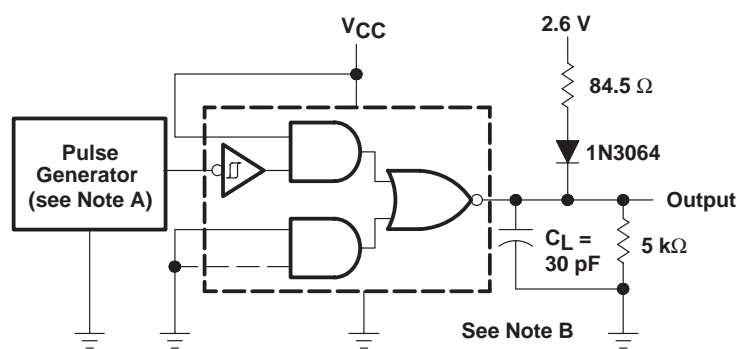

TEST CIRCUIT

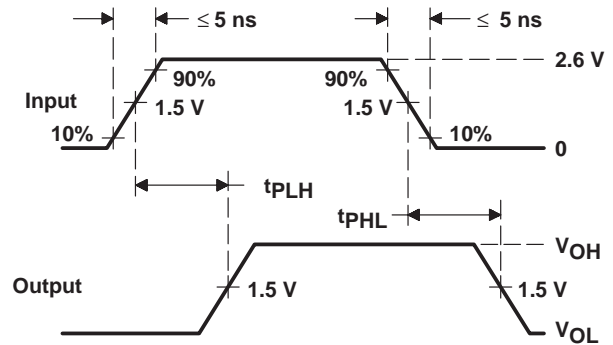

VOLTAGE WAVEFORMS

- NOTES: A. The pulse generator has the following characteristics: $Z_O \approx 50\ \Omega$, $PRR \leq 5\text{ MHz}$, duty cycle = 50%.
B. C_L includes probe and jig capacitance.

Figure 1. Test Circuit and Voltage Waveforms

TYPICAL CHARACTERISTICS

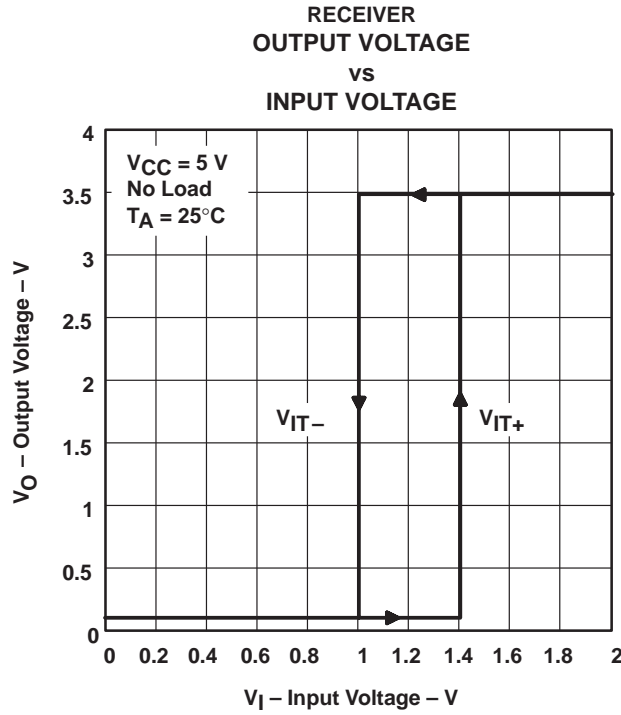

APPLICATION INFORMATION

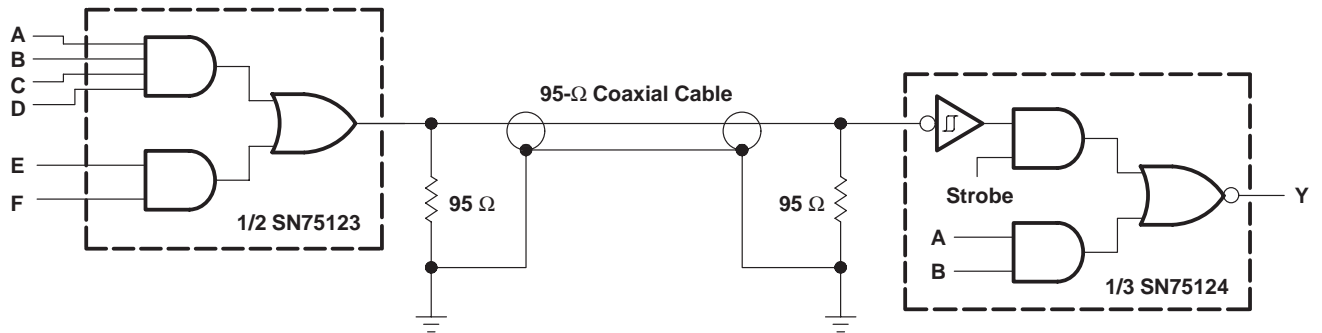

Figure 3. Unbalanced Line Communication Using SN75123 and SN75124

PACKAGING INFORMATION

Orderable Device	Status (1)	Package Type	Package Drawing	Pins	Package Qty	Eco Plan (2)	Lead finish/ Ball material (6)	MSL Peak Temp (3)	Op Temp (°C)	Device Marking (4/5)	Samples
SN75124N	ACTIVE	PDIP	N	16	25	RoHS & Green	NIPDAU	N / A for Pkg Type	0 to 70	SN75124N	Samples
SN75124NSR	ACTIVE	SO	NS	16	2000	RoHS & Green	NIPDAU	Level-1-260C-UNLIM	0 to 70	SN75124	Samples

(1) The marketing status values are defined as follows:

ACTIVE: Product device recommended for new designs.

LIFEBUY: TI has announced that the device will be discontinued, and a lifetime-buy period is in effect.

NRND: Not recommended for new designs. Device is in production to support existing customers, but TI does not recommend using this part in a new design.

PREVIEW: Device has been announced but is not in production. Samples may or may not be available.

OBSOLETE: TI has discontinued the production of the device.

(2) **RoHS:** TI defines "RoHS" to mean semiconductor products that are compliant with the current EU RoHS requirements for all 10 RoHS substances, including the requirement that RoHS substance do not exceed 0.1% by weight in homogeneous materials. Where designed to be soldered at high temperatures, "RoHS" products are suitable for use in specified lead-free processes. TI may reference these types of products as "Pb-Free".

RoHS Exempt: TI defines "RoHS Exempt" to mean products that contain lead but are compliant with EU RoHS pursuant to a specific EU RoHS exemption.

Green: TI defines "Green" to mean the content of Chlorine (Cl) and Bromine (Br) based flame retardants meet JS709B low halogen requirements of <=1000ppm threshold. Antimony trioxide based flame retardants must also meet the <=1000ppm threshold requirement.

(3) MSL, Peak Temp. - The Moisture Sensitivity Level rating according to the JEDEC industry standard classifications, and peak solder temperature.

(4) There may be additional marking, which relates to the logo, the lot trace code information, or the environmental category on the device.

(5) Multiple Device Markings will be inside parentheses. Only one Device Marking contained in parentheses and separated by a "~" will appear on a device. If a line is indented then it is a continuation of the previous line and the two combined represent the entire Device Marking for that device.

(6) Lead finish/Ball material - Orderable Devices may have multiple material finish options. Finish options are separated by a vertical ruled line. Lead finish/Ball material values may wrap to two lines if the finish value exceeds the maximum column width.

Important Information and Disclaimer:The information provided on this page represents TI's knowledge and belief as of the date that it is provided. TI bases its knowledge and belief on information provided by third parties, and makes no representation or warranty as to the accuracy of such information. Efforts are underway to better integrate information from third parties. TI has taken and continues to take reasonable steps to provide representative and accurate information but may not have conducted destructive testing or chemical analysis on incoming materials and chemicals. TI and TI suppliers consider certain information to be proprietary, and thus CAS numbers and other limited information may not be available for release.

In no event shall TI's liability arising out of such information exceed the total purchase price of the TI part(s) at issue in this document sold by TI to Customer on an annual basis.

TAPE AND REEL INFORMATION



QUADRANT ASSIGNMENTS FOR PIN 1 ORIENTATION IN TAPE



*All dimensions are nominal

Device	Package Type	Package Drawing	Pins	SPQ	Reel Diameter (mm)	Reel Width W1 (mm)	A0 (mm)	B0 (mm)	K0 (mm)	P1 (mm)	W (mm)	Pin1 Quadrant
SN75124NSR	SO	NS	16	2000	330.0	16.4	8.2	10.5	2.5	12.0	16.0	Q1

TAPE AND REEL BOX DIMENSIONS



*All dimensions are nominal

Device	Package Type	Package Drawing	Pins	SPQ	Length (mm)	Width (mm)	Height (mm)
SN75124NSR	SO	NS	16	2000	853.0	449.0	35.0

TUBE

*All dimensions are nominal

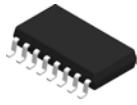
Device	Package Name	Package Type	Pins	SPQ	L (mm)	W (mm)	T (μm)	B (mm)
SN75124N	N	PDIP	16	25	506	13.97	11230	4.32



PACKAGE OUTLINE

NS0016A

SOP - 2.00 mm max height

SOP

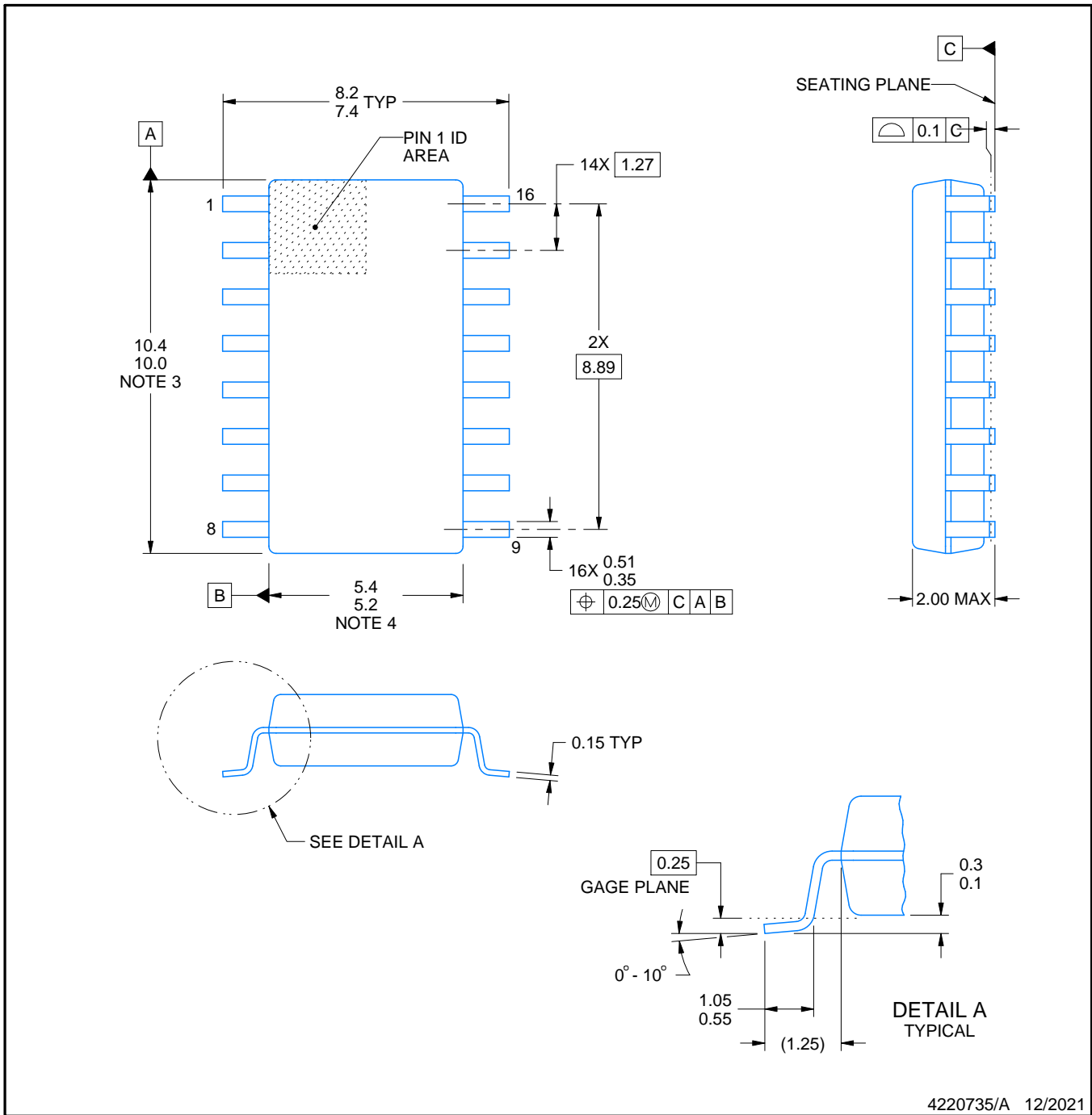

4220735/A 12/2021

NOTES:

1. All linear dimensions are in millimeters. Dimensions in parenthesis are for reference only. Dimensioning and tolerancing per ASME Y14.5M.
2. This drawing is subject to change without notice.
3. This dimension does not include mold flash, protrusions, or gate burrs. Mold flash, protrusions, or gate burrs shall not exceed 0.15 mm, per side.
4. This dimension does not include interlead flash. Interlead flash shall not exceed 0.25 mm, per side.

EXAMPLE BOARD LAYOUT

NS0016A

SOP - 2.00 mm max height

SOP

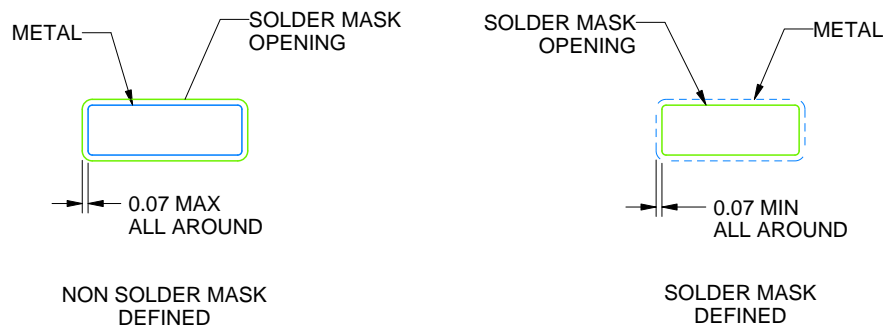
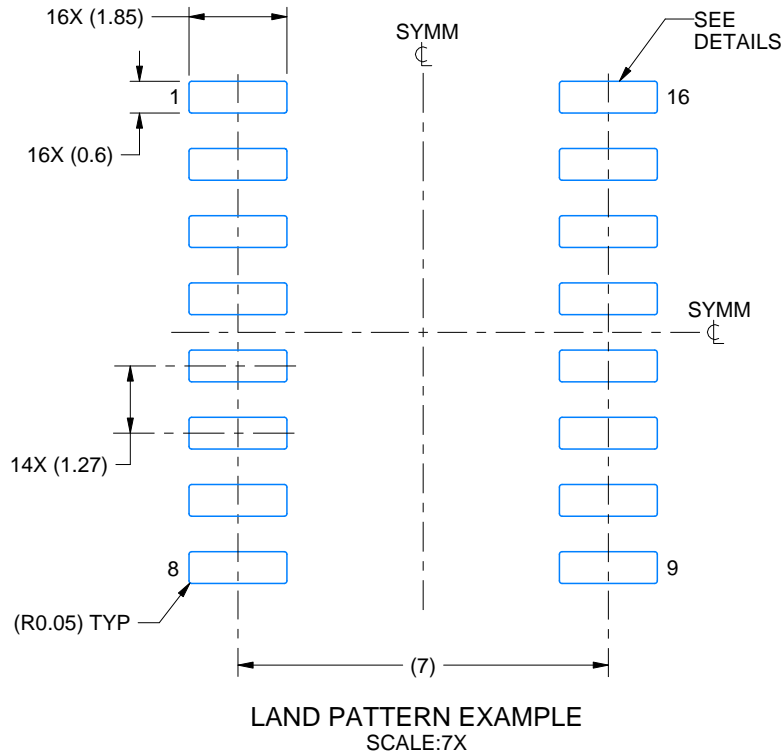

4220735/A 12/2021

NOTES: (continued)

5. Publication IPC-7351 may have alternate designs.

6. Solder mask tolerances between and around signal pads can vary based on board fabrication site.

EXAMPLE STENCIL DESIGN

NS0016A

SOP - 2.00 mm max height

SOP

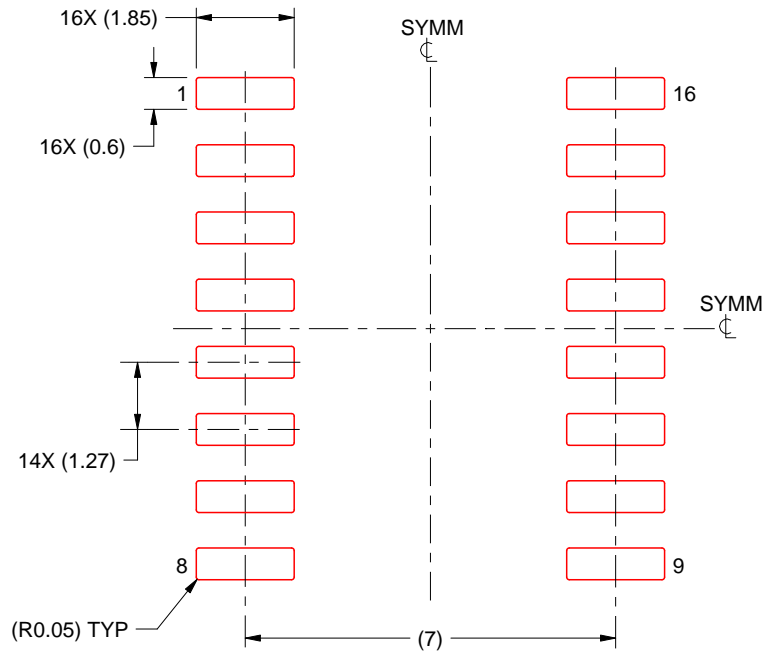

SOLDER PASTE EXAMPLE
BASED ON 0.125 mm THICK STENCIL
SCALE:7X

4220735/A 12/2021

NOTES: (continued)

7. Laser cutting apertures with trapezoidal walls and rounded corners may offer better paste release. IPC-7525 may have alternate design recommendations.
8. Board assembly site may have different recommendations for stencil design.

N (R-PDIP-T**)

PLASTIC DUAL-IN-LINE PACKAGE

16 PINS SHOWN



- NOTES:
- A. All linear dimensions are in inches (millimeters).
 - B. This drawing is subject to change without notice.
 - C Falls within JEDEC MS-001, except 18 and 20 pin minimum body length (Dim A).
 - D The 20 pin end lead shoulder width is a vendor option, either half or full width.

4040049/E 12/2002

MECHANICAL DATA

NS (R-PDSO-G**)

PLASTIC SMALL-OUTLINE PACKAGE

14-PINS SHOWN



- NOTES:
- A. All linear dimensions are in millimeters.
 - B. This drawing is subject to change without notice.
 - C. Body dimensions do not include mold flash or protrusion, not to exceed 0,15.

IMPORTANT NOTICE AND DISCLAIMER

TI PROVIDES TECHNICAL AND RELIABILITY DATA (INCLUDING DATA SHEETS), DESIGN RESOURCES (INCLUDING REFERENCE DESIGNS), APPLICATION OR OTHER DESIGN ADVICE, WEB TOOLS, SAFETY INFORMATION, AND OTHER RESOURCES "AS IS" AND WITH ALL FAULTS, AND DISCLAIMS ALL WARRANTIES, EXPRESS AND IMPLIED, INCLUDING WITHOUT LIMITATION ANY IMPLIED WARRANTIES OF MERCHANTABILITY, FITNESS FOR A PARTICULAR PURPOSE OR NON-INFRINGEMENT OF THIRD PARTY INTELLECTUAL PROPERTY RIGHTS.

These resources are intended for skilled developers designing with TI products. You are solely responsible for (1) selecting the appropriate TI products for your application, (2) designing, validating and testing your application, and (3) ensuring your application meets applicable standards, and any other safety, security, regulatory or other requirements.

These resources are subject to change without notice. TI grants you permission to use these resources only for development of an application that uses the TI products described in the resource. Other reproduction and display of these resources is prohibited. No license is granted to any other TI intellectual property right or to any third party intellectual property right. TI disclaims responsibility for, and you will fully indemnify TI and its representatives against, any claims, damages, costs, losses, and liabilities arising out of your use of these resources.

TI's products are provided subject to [TI's Terms of Sale](#) or other applicable terms available either on ti.com or provided in conjunction with such TI products. TI's provision of these resources does not expand or otherwise alter TI's applicable warranties or warranty disclaimers for TI products.

TI objects to and rejects any additional or different terms you may have proposed.

Mailing Address: Texas Instruments, Post Office Box 655303, Dallas, Texas 75265
Copyright © 2022, Texas Instruments Incorporated