

# SN65LBC173, SN75LBC173 QUADRUPLE LOW-POWER DIFFERENTIAL LINE RECEIVERS

SLLS170E – OCTOBER 1993 – REVISED AUGUST 2000

- Meets or Exceeds the Requirements of ANSI Standards EIA/TIA-422-B, EIA/TIA-423-B, RS-485, and ITU Recommendations V.10 and V.11.
- Designed to Operate With Pulse Durations as Short as 20 ns
- Designed for Multipoint Bus Transmission on Long Bus Lines in Noisy Environments
- Input Sensitivity . . .  $\pm 200$  mV
- Low-Power Consumption . . . 20 mA Max
- Open-Circuit Fail-Safe Design
- Pin Compatible With SN75173 and AM26LS32

D OR N PACKAGE  
(TOP VIEW)

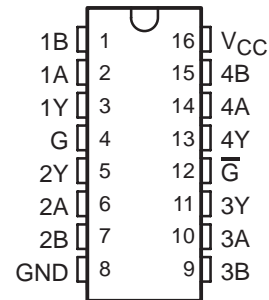

## description

The SN65LBC173 and SN75LBC173 are monolithic quadruple differential line receivers with 3-state outputs. Both are designed to meet the requirements of the ANSI standards EIA/TIA-422-B, EIA/TIA-423-B, RS-485, and ITU Recommendations V.10 and V.11. The devices are optimized for balanced multipoint bus transmission at data rates up to and exceeding 10 million bits per second. The four receivers share two ORed enable inputs, one active when high, the other active when low.

Each receiver features high input impedance, input hysteresis for increased noise immunity, and input sensitivity of  $\pm 200$  mV over a common-mode input voltage range of 12 V to  $-7$  V. Fail-safe design ensures that if the inputs are open circuited, the output is always high. Both devices are designed using the Texas Instruments proprietary LinBiCMOS™ technology that provides low power consumption, high switching speeds, and robustness.

These devices offer optimum performance when used with the SN75LBC172 or SN75LBC174 quadruple line drivers. The SN65LBC173 and SN75LBC173 are available in the 16-pin DIP (N) and SOIC (D) packages.

The SN65LBC173 is characterized over the industrial temperature range of  $-40^{\circ}\text{C}$  to  $85^{\circ}\text{C}$ . The SN75LBC173 is characterized for operation over the commercial temperature range of  $0^{\circ}\text{C}$  to  $70^{\circ}\text{C}$ .

FUNCTION TABLE  
(each receiver)

DIFFERENTIAL INPUTS A-B	ENABLES		OUTPUT Y
	G	$\bar{G}$	
$V_{ID} \geq 0.2$ V	H X	X L	H H
$-0.2$ V $< V_{ID} < 0.2$ V	H X	X L	? ?
$V_{ID} \leq -0.2$ V	H X	X L	L L
X	L	H	Z
Open Circuit	H X	X L	H H

H = high level, L = low level, X = irrelevant,  
Z = high impedance (off), ? = indeterminate



Please be aware that an important notice concerning availability, standard warranty, and use in critical applications of Texas Instruments semiconductor products and disclaimers thereto appears at the end of this data sheet.

LinBiCMOS is a trademark of Texas Instruments.

PRODUCTION DATA information is current as of publication date. Products conform to specifications per the terms of Texas Instruments standard warranty. Production processing does not necessarily include testing of all parameters.



POST OFFICE BOX 655303 • DALLAS, TEXAS 75265

Copyright © 2000, Texas Instruments Incorporated

# SN65LBC173, SN75LBC173 QUADRUPLE LOW-POWER DIFFERENTIAL LINE RECEIVERS

SLLS170E – OCTOBER 1993 – REVISED AUGUST 2000

## logic symbol†

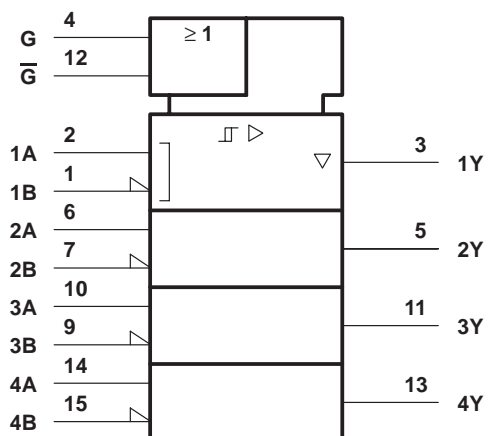

† This symbol is in accordance with ANSI/IEEE Std 91-1984 and IEC Publication 617-12.

## logic diagram (positive logic)

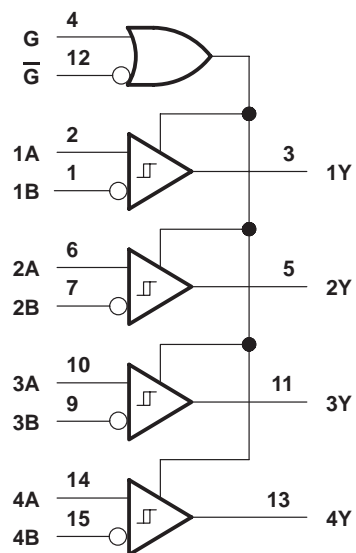

## schematics of inputs and outputs

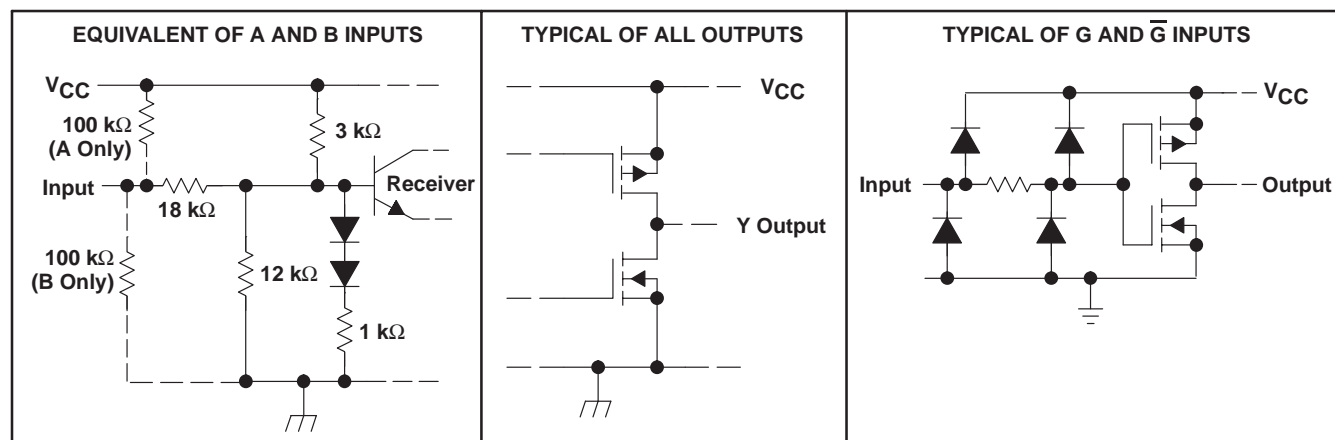

# SN65LBC173, SN75LBC173 QUADRUPLE LOW-POWER DIFFERENTIAL LINE RECEIVERS

SLLS170E – OCTOBER 1993 – REVISED AUGUST 2000

## absolute maximum ratings over operating free-air temperature range (unless otherwise noted)†

Supply voltage range, $V_{CC}$ (see Note 1)	–0.3 V to 7 V
Input voltage, $V_I$ (A or B inputs)	±25 V
Differential input voltage, $V_{ID}$ (see Note 2)	±25 V
Voltage range at Y, G, $\overline{G}$	–0.3 V to $V_{CC} + 0.5$ V
Continuous total dissipation	See Dissipation Rating Table
Operating free-air temperature range, $T_A$ : SN65LBC173	–40°C to 85°C
SN75LBC173	0°C to 70°C
Storage temperature range, $T_{stg}$	–65°C to 150°C
Lead temperature 1,6 mm (1/16 inch) from case for 10 seconds	260°C

† Stresses beyond those listed under “absolute maximum ratings” may cause permanent damage to the device. These are stress ratings only, and functional operation of the device at these or any other conditions beyond those indicated under “recommended operating conditions” is not implied. Exposure to absolute-maximum-rated conditions for extended periods may affect device reliability.

NOTES: 1. All voltage values are with respect to GND.

2. Differential input voltage is measured at the noninverting input with respect to the corresponding inverting input.

**DISSIPATION RATING TABLE**

PACKAGE	$T_A \leq 25^\circ\text{C}$ POWER RATING	DERATING FACTOR ABOVE $T_A = 25^\circ\text{C}$	$T_A = 70^\circ\text{C}$ POWER RATING	$T_A = 85^\circ\text{C}$ POWER RATING
D	1100 mW	8.7 mW/°C	708 mW	578 mW
N	1150 mW	9.2 mW/°C	736 mW	598 mW

## recommended operating conditions

		MIN	NOM	MAX	UNIT
Supply voltage, $V_{CC}$		4.75	5	5.25	V
Common-mode input voltage, $V_{IC}$		–7		12	V
Differential input voltage, $V_{ID}$				±6	V
High-level input voltage, $V_{IH}$	G inputs	2			V
Low-level input voltage, $V_{IL}$				0.8	V
High-level output current, $I_{OH}$				–8	mA
Low-level output current, $I_{OL}$				8	mA
Operating free-air temperature, $T_A$	SN65LBC173	–40		85	°C
	SN75LBC173	0		70	



# SN65LBC173, SN75LBC173 QUADRUPLE LOW-POWER DIFFERENTIAL LINE RECEIVERS

SLLS170E – OCTOBER 1993 – REVISED AUGUST 2000

electrical characteristics over recommended ranges of supply voltage and operating free-air temperature (unless otherwise noted)

PARAMETER		TEST CONDITIONS	MIN	TYP†	MAX	UNIT	
$V_{IT+}$	Positive-going input threshold voltage	$I_O = -8 \text{ mA}$			0.2	V	
$V_{IT-}$	Negative-going input threshold voltage	$I_O = 8 \text{ mA}$	-0.2			V	
$V_{hys}$	Hysteresis voltage ( $V_{IT+} - V_{IT-}$ )			45		mV	
$V_{IK}$	Enable input clamp voltage	$I_I = -18 \text{ mA}$		-0.9	-1.5	V	
$V_{OH}$	High-level output voltage	$V_{ID} = 200 \text{ mV}$ , $I_{OH} = -8 \text{ mA}$	3.5	4.5		V	
$V_{OL}$	Low-level output voltage	$V_{ID} = -200 \text{ mV}$ , $I_{OL} = 8 \text{ mA}$		0.3	0.5	V	
$I_{OZ}$	High-impedance-state output current	$V_O = 0 \text{ V to } V_{CC}$			$\pm 20$	$\mu\text{A}$	
$I_I$	Bus input current	A or B inputs	$V_{IH} = 12 \text{ V}$ , $V_{CC} = 5 \text{ V}$ , Other inputs at 0 V		0.7	1	mA
			$V_{IH} = 12 \text{ V}$ , $V_{CC} = 0 \text{ V}$ , Other inputs at 0 V		0.8	1	
			$V_{IH} = -7 \text{ V}$ , $V_{CC} = 5 \text{ V}$ , Other inputs at 0 V		-0.5	-0.8	
			$V_{IH} = -7 \text{ V}$ , $V_{CC} = 0 \text{ V}$ , Other inputs at 0 V		-0.4	-0.8	
$I_{IH}$	High-level input current	$V_{IH} = 5 \text{ V}$			$\pm 20$	$\mu\text{A}$	
$I_{IL}$	Low-level input current	$V_{IL} = 0 \text{ V}$			-20	$\mu\text{A}$	
$I_{OS}$	Short-circuit output current	$V_O = 0$		-80	-120	mA	
$I_{CC}$	Supply current	Outputs enabled, $I_O = 0$ , $V_{ID} = 5 \text{ V}$		11	20	mA	
		Outputs disabled		0.9	1.4		

† All typical values are at  $V_{CC} = 5 \text{ V}$  and  $T_A = 25^\circ\text{C}$ .

## switching characteristics, $V_{CC} = 5 \text{ V}$ , $C_L = 15 \text{ pF}$ , $T_A = 25^\circ\text{C}$

PARAMETER		TEST CONDITIONS	MIN	TYP	MAX	UNIT
$t_{PHL}$	Propagation delay time, high- to low-level output	$V_{ID} = -1.5 \text{ V to } 1.5 \text{ V}$ , See Figure 1	11	22	30	ns
$t_{PLH}$	Propagation delay time, low- to high-level output		11	22	30	ns
$t_{PZH}$	Output enable time to high level	See Figure 2		17	30	ns
$t_{PZL}$	Output enable time to low level	See Figure 3		18	30	ns
$t_{PHZ}$	Output disable time from high level	See Figure 2		35	45	ns
$t_{PLZ}$	Output disable time from low level	See Figure 3		25	40	ns
$t_{sk(p)}$	Pulse skew ( $ t_{PHL} - t_{PLH} $ )	See Figure 2		0.5	6	ns
$t_t$	Transition time	See Figure 1		5	10	ns

# SN65LBC173, SN75LBC173 QUADRUPLE LOW-POWER DIFFERENTIAL LINE RECEIVERS

SLLS170E – OCTOBER 1993 – REVISED AUGUST 2000

## PARAMETER MEASUREMENT INFORMATION

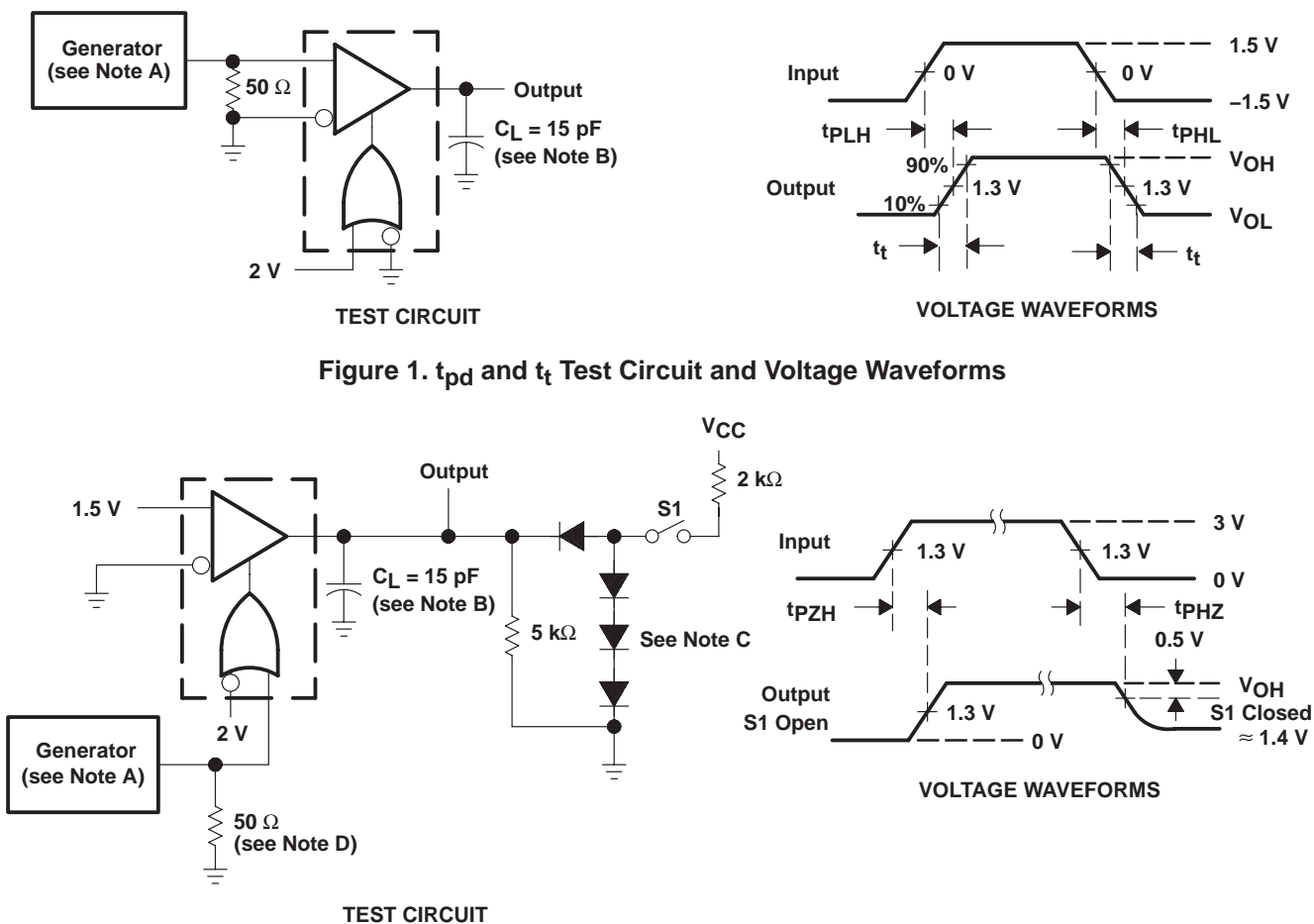

- NOTES: A. The input pulse is supplied by a generator having the following characteristics: PRR = 1 MHz, duty cycle = 50%,  $t_r \leq 6$  ns,  $t_f \leq 6$  ns,  $Z_O = 50 \Omega$ .
- B.  $C_L$  includes probe and jig capacitance.
- C. All diodes are 1N916 or equivalent.
- D. To test the active-low enable  $\bar{G}$ , ground  $\bar{G}$  and apply an inverted input waveform to  $\bar{G}$ .

**Figure 2.  $t_{PHZ}$  and  $t_{pZH}$  Test Circuit and Voltage Waveforms**

# SN65LBC173, SN75LBC173 QUADRUPLE LOW-POWER DIFFERENTIAL LINE RECEIVERS

SLLS170E – OCTOBER 1993 – REVISED AUGUST 2000

## PARAMETER MEASUREMENT INFORMATION

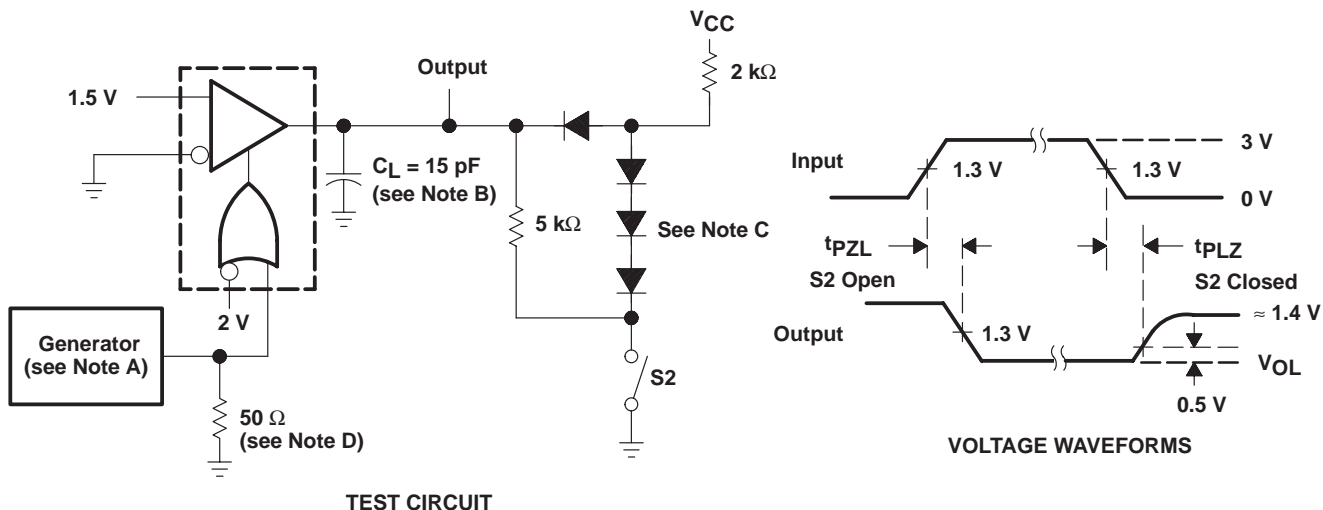

TEST CIRCUIT

- NOTES: A. The input pulse is supplied by a generator having the following characteristics: PRR = 1 MHz, duty cycle = 50%,  $t_r \leq 6$  ns,  $t_f \leq 6$  ns,  $Z_O = 50 \Omega$ .  
 B.  $C_L$  includes probe and jig capacitance.  
 C. All diodes are 1N916 or equivalent.  
 D. To test the active-low enable  $\overline{G}$ , ground G and apply an inverted input waveform to  $\overline{G}$ .

Figure 3.  $t_{PZL}$  and  $t_{PLZ}$  Test Circuit and Voltage Waveforms

## TYPICAL CHARACTERISTICS

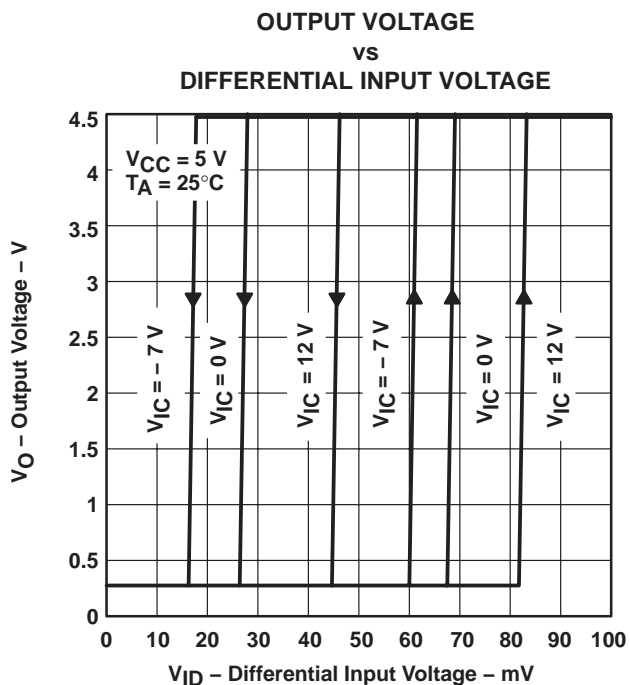

Figure 4

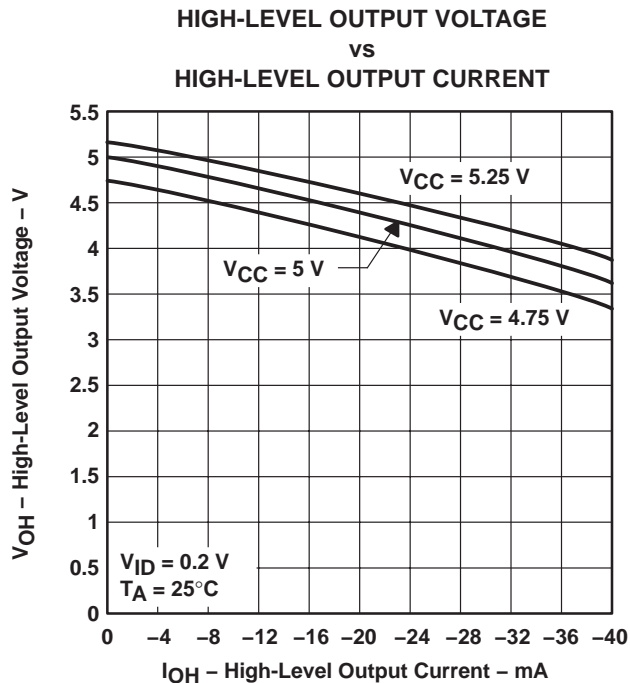

Figure 5

# SN65LBC173, SN75LBC173 QUADRUPLE LOW-POWER DIFFERENTIAL LINE RECEIVERS

SLLS170E – OCTOBER 1993 – REVISED AUGUST 2000

## TYPICAL CHARACTERISTICS

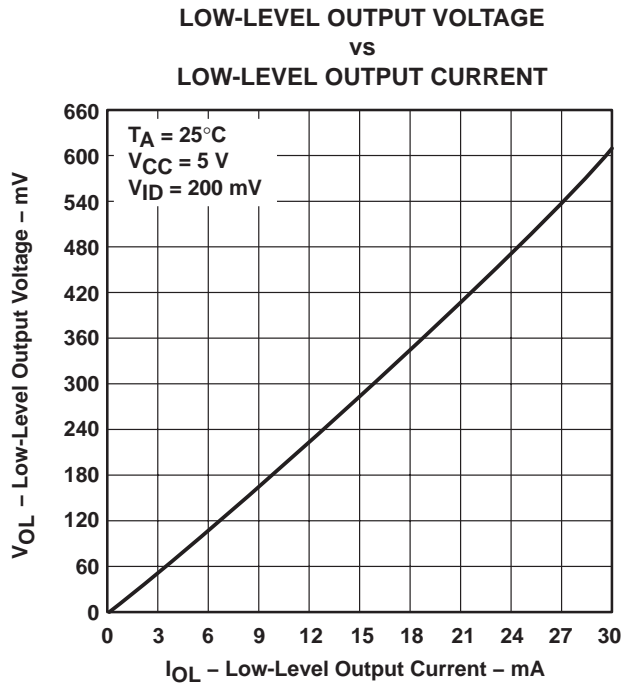

Figure 6

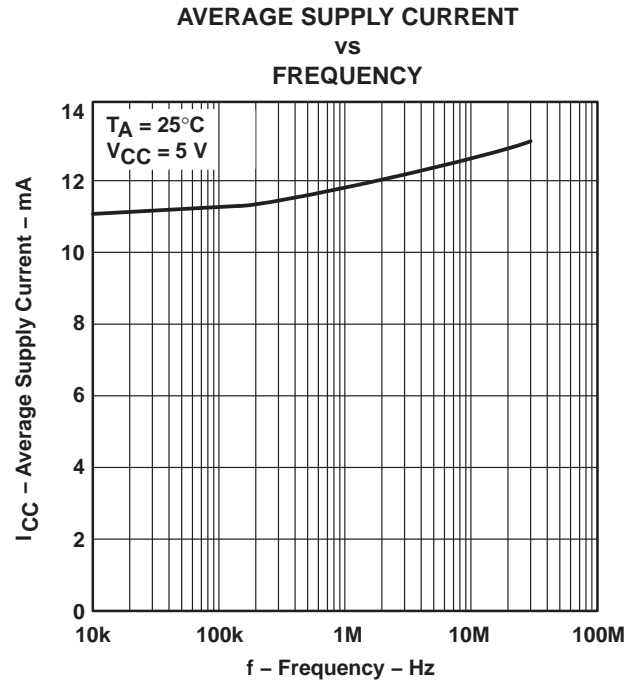

Figure 7

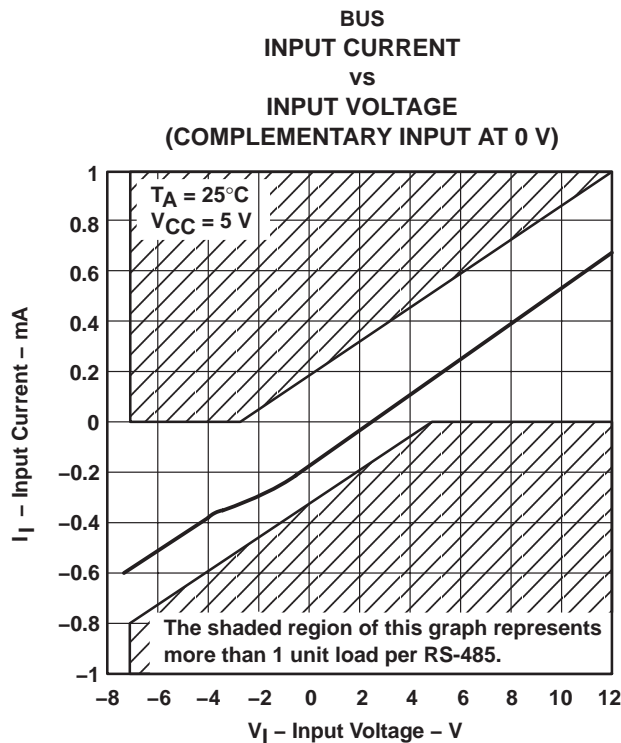

Figure 8

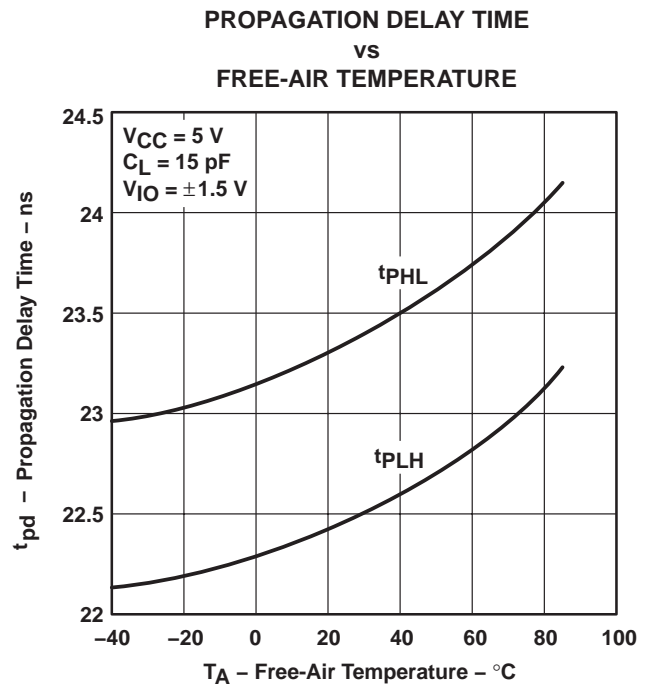

Figure 9

# SN65LBC173, SN75LBC173 QUADRUPLE LOW-POWER DIFFERENTIAL LINE RECEIVERS

SLLS170E – OCTOBER 1993 – REVISED AUGUST 2000

## MECHANICAL DATA

D (R-PDSO-G\*\*)

PLASTIC SMALL-OUTLINE PACKAGE

14 PIN SHOWN

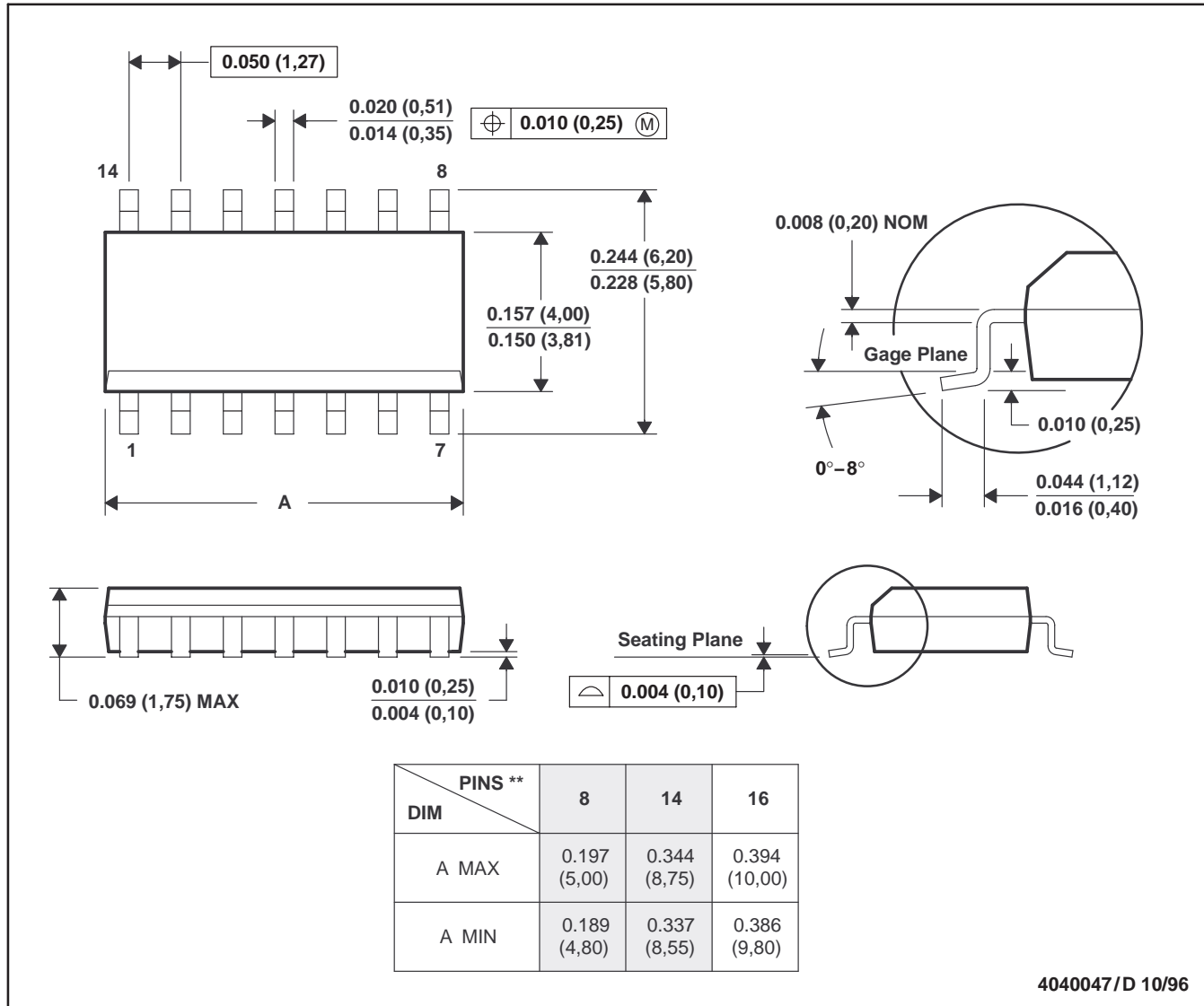

- NOTES: A. All linear dimensions are in inches (millimeters).  
 B. This drawing is subject to change without notice.  
 C. Body dimensions do not include mold flash or protrusion, not to exceed 0.006 (0,15).  
 D. Falls within JEDEC MS-012

# SN65LBC173, SN75LBC173 QUADRUPLE LOW-POWER DIFFERENTIAL LINE RECEIVERS

SLLS170E – OCTOBER 1993 – REVISED AUGUST 2000

## MECHANICAL DATA

N (R-PDIP-T\*\*)

PLASTIC DUAL-IN-LINE PACKAGE

16 PIN SHOWN

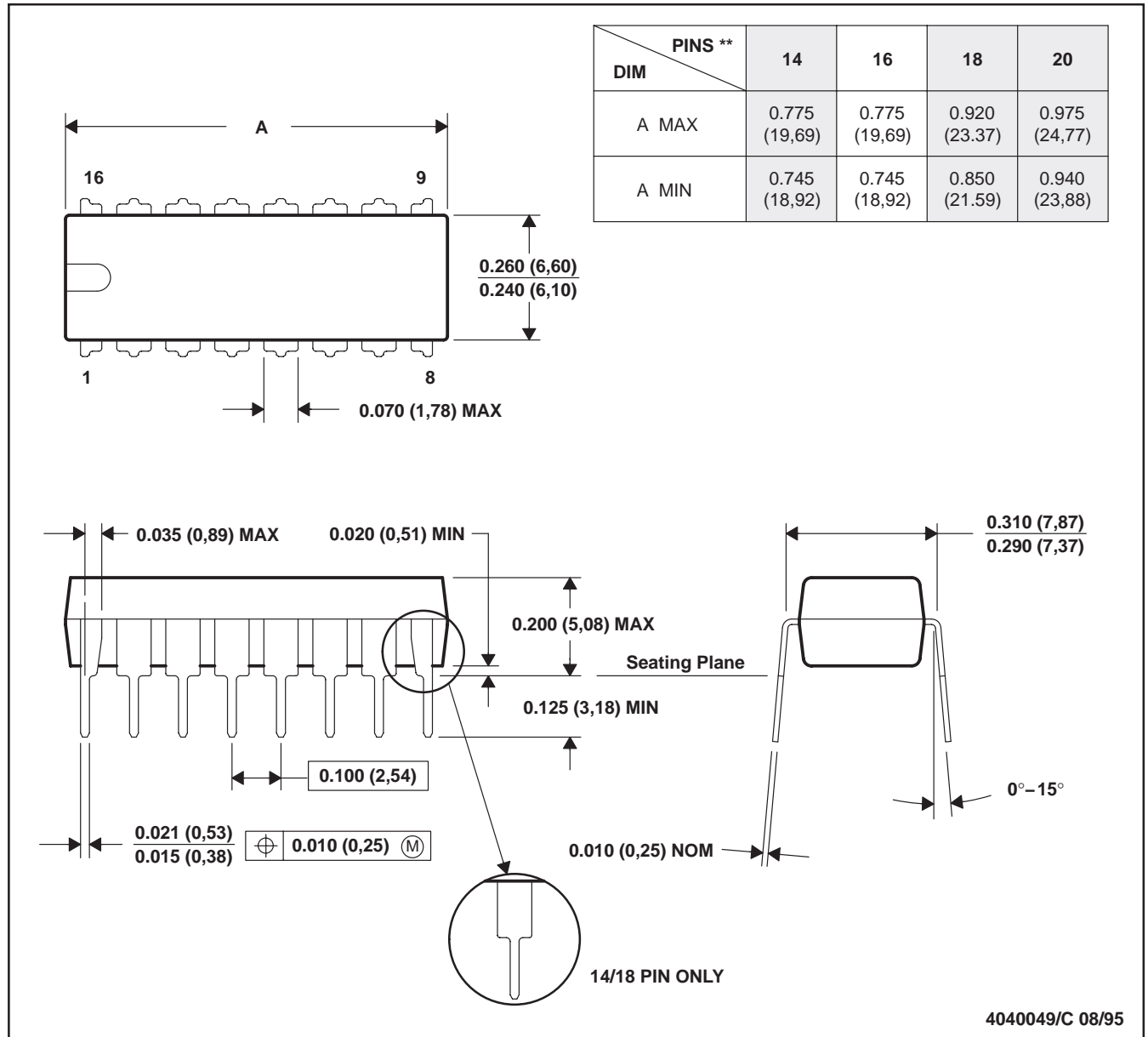

- NOTES: A. All linear dimensions are in inches (millimeters).  
 B. This drawing is subject to change without notice.  
 C. Falls within JEDEC MS-001 (20 pin package is shorter than MS-001.)

**PACKAGING INFORMATION**

Orderable Device	Status (1)	Package Type	Package Drawing	Pins	Package Qty	Eco Plan (2)	Lead finish/ Ball material (6)	MSL Peak Temp (3)	Op Temp (°C)	Device Marking (4/5)	Samples
SN65LBC173D	ACTIVE	SOIC	D	16	40	RoHS & Green	NIPDAU	Level-1-260C-UNLIM	-40 to 85	65LBC173	<a href="#">Samples</a>
SN65LBC173DR	ACTIVE	SOIC	D	16	2500	RoHS & Green	NIPDAU	Level-1-260C-UNLIM	-40 to 85	65LBC173	<a href="#">Samples</a>
SN65LBC173N	ACTIVE	PDIP	N	16	25	RoHS & Green	NIPDAU	N / A for Pkg Type	-40 to 85	SN65LBC173N	<a href="#">Samples</a>
SN75LBC173D	ACTIVE	SOIC	D	16	40	RoHS & Green	NIPDAU	Level-1-260C-UNLIM	0 to 70	75LBC173	<a href="#">Samples</a>
SN75LBC173DR	ACTIVE	SOIC	D	16	2500	RoHS & Green	NIPDAU	Level-1-260C-UNLIM	0 to 70	75LBC173	<a href="#">Samples</a>
SN75LBC173DRG4	ACTIVE	SOIC	D	16	2500	RoHS & Green	NIPDAU	Level-1-260C-UNLIM	0 to 70	75LBC173	<a href="#">Samples</a>
SN75LBC173N	ACTIVE	PDIP	N	16	25	RoHS & Green	NIPDAU	N / A for Pkg Type	0 to 70	SN75LBC173N	<a href="#">Samples</a>
SN75LBC173NE4	ACTIVE	PDIP	N	16	25	RoHS & Green	NIPDAU	N / A for Pkg Type	0 to 70	SN75LBC173N	<a href="#">Samples</a>

(1) The marketing status values are defined as follows:

**ACTIVE:** Product device recommended for new designs.

**LIFEBUY:** TI has announced that the device will be discontinued, and a lifetime-buy period is in effect.

**NRND:** Not recommended for new designs. Device is in production to support existing customers, but TI does not recommend using this part in a new design.

**PREVIEW:** Device has been announced but is not in production. Samples may or may not be available.

**OBSELETE:** TI has discontinued the production of the device.

(2) **RoHS:** TI defines "RoHS" to mean semiconductor products that are compliant with the current EU RoHS requirements for all 10 RoHS substances, including the requirement that RoHS substance do not exceed 0.1% by weight in homogeneous materials. Where designed to be soldered at high temperatures, "RoHS" products are suitable for use in specified lead-free processes. TI may reference these types of products as "Pb-Free".

**RoHS Exempt:** TI defines "RoHS Exempt" to mean products that contain lead but are compliant with EU RoHS pursuant to a specific EU RoHS exemption.

**Green:** TI defines "Green" to mean the content of Chlorine (Cl) and Bromine (Br) based flame retardants meet JS709B low halogen requirements of <=1000ppm threshold. Antimony trioxide based flame retardants must also meet the <=1000ppm threshold requirement.

(3) MSL, Peak Temp. - The Moisture Sensitivity Level rating according to the JEDEC industry standard classifications, and peak solder temperature.

(4) There may be additional marking, which relates to the logo, the lot trace code information, or the environmental category on the device.

(5) Multiple Device Markings will be inside parentheses. Only one Device Marking contained in parentheses and separated by a "~" will appear on a device. If a line is indented then it is a continuation of the previous line and the two combined represent the entire Device Marking for that device.

<sup>(6)</sup> Lead finish/Ball material - Orderable Devices may have multiple material finish options. Finish options are separated by a vertical ruled line. Lead finish/Ball material values may wrap to two lines if the finish value exceeds the maximum column width.

**Important Information and Disclaimer:**The information provided on this page represents TI's knowledge and belief as of the date that it is provided. TI bases its knowledge and belief on information provided by third parties, and makes no representation or warranty as to the accuracy of such information. Efforts are underway to better integrate information from third parties. TI has taken and continues to take reasonable steps to provide representative and accurate information but may not have conducted destructive testing or chemical analysis on incoming materials and chemicals. TI and TI suppliers consider certain information to be proprietary, and thus CAS numbers and other limited information may not be available for release.

In no event shall TI's liability arising out of such information exceed the total purchase price of the TI part(s) at issue in this document sold by TI to Customer on an annual basis.

**OTHER QUALIFIED VERSIONS OF SN75LBC173 :**

- Military : [SN55LBC173](#)

NOTE: Qualified Version Definitions:

- Military - QML certified for Military and Defense Applications

**TAPE AND REEL INFORMATION**

**QUADRANT ASSIGNMENTS FOR PIN 1 ORIENTATION IN TAPE**

\*All dimensions are nominal

Device	Package Type	Package Drawing	Pins	SPQ	Reel Diameter (mm)	Reel Width W1 (mm)	A0 (mm)	B0 (mm)	K0 (mm)	P1 (mm)	W (mm)	Pin1 Quadrant
SN65LBC173DR	SOIC	D	16	2500	330.0	16.4	6.5	10.3	2.1	8.0	16.0	Q1
SN75LBC173DR	SOIC	D	16	2500	330.0	16.4	6.5	10.3	2.1	8.0	16.0	Q1

**TAPE AND REEL BOX DIMENSIONS**

\*All dimensions are nominal

Device	Package Type	Package Drawing	Pins	SPQ	Length (mm)	Width (mm)	Height (mm)
SN65LBC173DR	SOIC	D	16	2500	340.5	336.1	32.0
SN75LBC173DR	SOIC	D	16	2500	340.5	336.1	32.0

**TUBE**

\*All dimensions are nominal

Device	Package Name	Package Type	Pins	SPQ	L (mm)	W (mm)	T (μm)	B (mm)
SN65LBC173D	D	SOIC	16	40	507	8	3940	4.32
SN65LBC173D	D	SOIC	16	40	505.46	6.76	3810	4
SN65LBC173N	N	PDIP	16	25	506	13.97	11230	4.32
SN75LBC173D	D	SOIC	16	40	507	8	3940	4.32
SN75LBC173D	D	SOIC	16	40	505.46	6.76	3810	4
SN75LBC173N	N	PDIP	16	25	506	13.97	11230	4.32
SN75LBC173NE4	N	PDIP	16	25	506	13.97	11230	4.32

## IMPORTANT NOTICE AND DISCLAIMER

TI PROVIDES TECHNICAL AND RELIABILITY DATA (INCLUDING DATA SHEETS), DESIGN RESOURCES (INCLUDING REFERENCE DESIGNS), APPLICATION OR OTHER DESIGN ADVICE, WEB TOOLS, SAFETY INFORMATION, AND OTHER RESOURCES "AS IS" AND WITH ALL FAULTS, AND DISCLAIMS ALL WARRANTIES, EXPRESS AND IMPLIED, INCLUDING WITHOUT LIMITATION ANY IMPLIED WARRANTIES OF MERCHANTABILITY, FITNESS FOR A PARTICULAR PURPOSE OR NON-INFRINGEMENT OF THIRD PARTY INTELLECTUAL PROPERTY RIGHTS.

These resources are intended for skilled developers designing with TI products. You are solely responsible for (1) selecting the appropriate TI products for your application, (2) designing, validating and testing your application, and (3) ensuring your application meets applicable standards, and any other safety, security, regulatory or other requirements.

These resources are subject to change without notice. TI grants you permission to use these resources only for development of an application that uses the TI products described in the resource. Other reproduction and display of these resources is prohibited. No license is granted to any other TI intellectual property right or to any third party intellectual property right. TI disclaims responsibility for, and you will fully indemnify TI and its representatives against, any claims, damages, costs, losses, and liabilities arising out of your use of these resources.

TI's products are provided subject to [TI's Terms of Sale](#) or other applicable terms available either on [ti.com](http://ti.com) or provided in conjunction with such TI products. TI's provision of these resources does not expand or otherwise alter TI's applicable warranties or warranty disclaimers for TI products.

TI objects to and rejects any additional or different terms you may have proposed.

Mailing Address: Texas Instruments, Post Office Box 655303, Dallas, Texas 75265  
Copyright © 2022, Texas Instruments Incorporated