

SN65LBC171, SN75LBC171 TRIPLE DIFFERENTIAL TRANSCIEVERS

SLLS460A – NOVEMBER 2000 – REVISED FEBRUARY 2001

AVAILABLE OPTIONS†

T _A	PACKAGE	
	PLASTIC SMALL-OUTLINE (JEDEC MS-013)	PLASTIC SHRINK SMALL-OUTLINE (JEDEC MO-150)
0°C to 70°C	SN75LBC171DW	SN75LBC171DB
-40°C to 85°C	SN65LBC171DW	SN65LBC171DB

† Add R suffix for taped and reel

Function Tables

EACH DRIVER

INPUT D	ENABLE		OUTPUTS	
	DE	CDE	A	B
H	H	H	H	L
L	H	H	L	H
OPEN	H	H	L	H
X	L	X	Z	Z
X	X	L	Z	Z
X	OPEN	X	Z	Z
X	X	OPEN	Z	Z

EACH RECEIVER

DIFFERENTIAL INPUT (V _A -V _B)	ENABLE RE	OUTPUT R
V _{ID} ≥ 0.2 V	L	H
-0.2 V < V _{ID} < 0.2 V	L	?
V _{ID} ≤ -0.2 V	L	L
X	H	Z
OPEN	L	H

H = high level, L = low level, X = irrelevant,
Z = high impedance (off), ? = indeterminate

equivalent input and output schematic diagrams

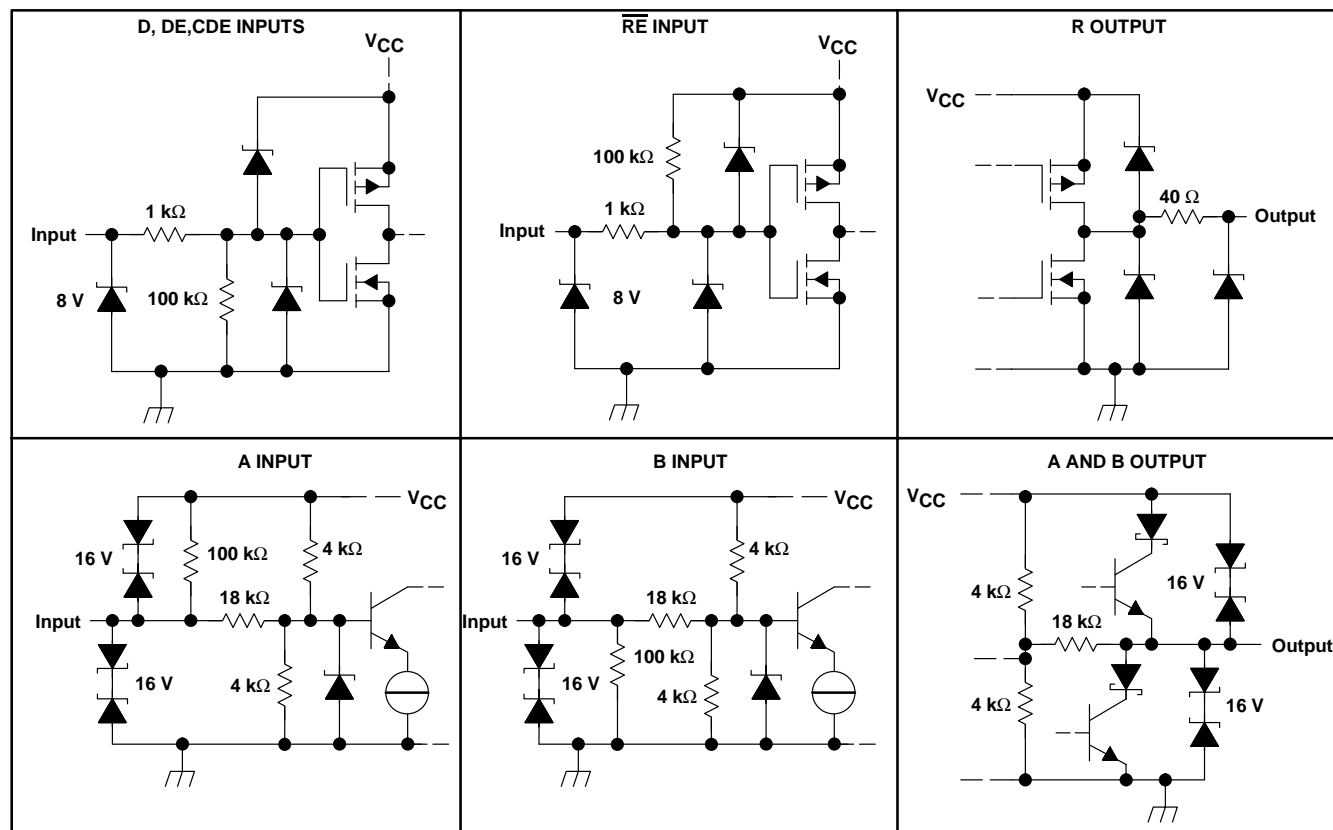

SN65LBC171, SN75LBC171 TRIPLE DIFFERENTIAL TRANSCEIVERS

SLLS460A – NOVEMBER 2000 – REVISED FEBRUARY 2001

absolute maximum ratings†

Supply voltage, V_{CC} (see Note 1)	–0.3 V to 6 V
Voltage range at any bus I/O terminal (steady state)	–10 V to 15 V
Voltage input range, A and B, (transient pulse through 100 Ω , see Figure 12)	–30 V to 30 V
Voltage range at any DE, \overline{RE} , or CDE terminal	–0.5 V to $V_{CC} + 0.5$ V
Electrostatic discharge: Human body model (A, B, GND) (see Note 2)	12 kV
All pins	5 kV
Charged-device model (all pins) (see Note 3)	1 kV
Continuous total power dissipation	See Power Dissipation Rating Table
Storage temperature range, T_{stg}	–65°C to 150°C
Lead temperature 1,6 mm (1/16 inch) from case for 10 seconds	260°C

† Stresses beyond those listed under “absolute maximum ratings” may cause permanent damage to the device. These are stress ratings only, and functional operation of the device at these or any other conditions beyond those indicated under “recommended operating conditions” is not implied. Exposure to absolute-maximum-rated conditions for extended periods may affect device reliability.

- NOTES: 1. All voltage values, except differential I/O bus voltages, are with respect to network ground terminal.
 2. Tested in accordance with JEDEC Standard 22, Test Method A114–A.
 3. Tested in accordance with JEDEC Standard 22, Test Method C101.

POWER DISSIPATION RATING TABLE

PACKAGE	$T_A \leq 25^\circ\text{C}$	DERATING FACTOR‡	$T_A = 70^\circ\text{C}$	$T_A = 85^\circ\text{C}$
	POWER RATING	ABOVE $T_A = 25^\circ\text{C}$	POWER RATING	POWER RATING
DB	995 mW	8.0 mW/°C	635 mW	515 mW
DW	1480 mW	11.8 mW/°C	950 mW	770 mW

‡ This is the inverse of the junction-to-ambient thermal resistance when board-mounted and with no air flow.

recommended operating conditions

		MIN	NOM	MAX	UNIT
Supply voltage, V_{CC}		4.75	5	5.25	V
Voltage at any bus I/O terminal	A, B	–7		12	V
High-level input voltage, V_{IH}	DE, CDE, RE	2		V_{CC}	V
Low-level input voltage, V_{IL}		0		0.8	
Differential input voltage, V_{ID}	A with respect to B	–12		12	V
Output current	Driver	–60		60	mA
	Receiver	–8		8	
Operating free-air temperature, T_A	SN75LBC171	0		70	°C
	SN65LBC171	–40		85	



SN65LBC171, SN75LBC171 TRIPLE DIFFERENTIAL TRANSCEIVERS

SLLS460A – NOVEMBER 2000 – REVISED FEBRUARY 2001

DRIVER SECTION

electrical characteristics over recommended operating conditions

PARAMETER		TEST CONDITIONS	MIN	TYP†	MAX	UNIT	
V_{IK}	Input clamp voltage	D, DE, CDE $I_I = 18 \text{ mA}$	-1.5	-0.7		V	
V_O	Open-circuit output voltage (single-ended)	A or B, No load	0		V_{CC}	V	
$ V_{OD(SS)} $	Steady-state differential output voltage magnitude‡	No load	3.8	4.3	V_{CC}	V	
		$R_L = 54 \Omega$, See Figure 1	1	1.6	2.4	V	
		With common-mode loading, See Figure 2	1	1.6	2.4	V	
ΔV_{OD}	Change in differential output voltage magnitude, $ V_{OD(H)} - V_{OD(L)} $	$R_L = 54 \Omega$, $C_L = 50 \text{ pF}$	See Figure 1	-0.2	0.2	V	
$V_{OC(SS)}$	Steady-state common-mode output voltage			2	2.4	2.8	V
$\Delta V_{OC(SS)}$	Change in steady-state common-mode output voltage ($V_{OC(H)} - V_{OC(L)}$)			-0.2	0.2	V	
I_I	Input current	D, DE, CDE	-100		100	μA	
I_O	Output current with power off	$V_{CC} = 0 \text{ V}$, $V_O = -7 \text{ V to } 12 \text{ V}$	-700		900	μA	
I_{OS}	Short-circuit output current	$V_O = -7 \text{ V to } 12 \text{ V}$, See Figure 7	-250		250	mA	
I_{CC}	Supply current (driver enabled)	D at 0 V or V_{CC} , CDE, DE, \overline{RE} at V_{CC} , No load		14	20	mA	

† All typical values are at $V_{CC} = 5 \text{ V}$ and $T_A = 25^\circ\text{C}$.

‡ The minimum V_{OD} may not fully comply with TIA/EIA-485-A at operating temperatures below 0°C . System designers should take the possibly lower output signal into account in determining the maximum signal-transmission distance.

switching characteristics over recommended operating conditions

PARAMETER		TEST CONDITIONS	MIN	TYP	MAX	UNIT
t_{PLH}	Differential output propagation delay, low-to-high	$R_L = 54 \Omega$, See Figure 3 $C_L = 50 \text{ pF}$,	4	8.5	12	ns
t_{PHL}	Differential output propagation delay, high-to-low		4	8.5	11	
t_r	Differential output rise time		3	7.5	11	
t_f	Differential output fall time		3	7.5	11	
$t_{sk(p)}$	Pulse skew $ (t_{PLH} - t_{PHL}) $				2	
$t_{sk(o)}$	Output skew§				1.5	
$t_{sk(pp)}$	Part-to-part skew¶				2	
t_{PLH}	Differential output propagation delay, low-to-high	See Figure 4, (HVD SCSI double-terminated load)	3	7	10	ns
t_{PHL}	Differential output propagation delay, high-to-low		3	7.5	10	
t_r	Differential output rise time		3	7.5	12	
t_f	Differential output fall time		3	7.5	12	
$t_{sk(p)}$	Pulse skew $ (t_{PLH} - t_{PHL}) $				3	
$t_{sk(o)}$	Output skew§				1.5	
$t_{sk(pp)}$	Part-to-part skew¶				2.5	
t_{PZH}	Output enable time to high level	See Figure 5		15	25	ns
t_{PHZ}	Output disable time from high level			18	25	
t_{PZL}	Output enable time to low level	See Figure 6		10	25	ns
t_{PLZ}	Output disable time from low level			17	25	

§ Output skew ($t_{sk(o)}$) is the magnitude of the time delay difference between the outputs of a single device with all of the inputs connected together.

¶ Part-to-part skew ($t_{sk(pp)}$) is the magnitude of the difference in propagation delay times between any specified terminals of two devices when both devices operate with the same input signals, the same supply voltages, at the same temperature, and have identical packages and test circuits.



RECEIVER SECTION

electrical characteristics over recommended operating conditions

PARAMETER		TEST CONDITIONS	MIN	TYP†	MAX	UNIT
V_{IT+}	Positive-going differential input voltage threshold				0.2	V
V_{IT-}	Negative-going differential input voltage threshold		-0.2			
V_{hys}	Hysteresis voltage ($V_{IT+} - V_{IT-}$)			40		mV
V_{OH}	High-level output voltage	$V_{ID} = 200\text{ mV}$, $I_{OH} = -8\text{ mA}$, see Figure 10	4	4.7	V_{CC}	V
V_{OL}	Low-level output voltage	$V_{ID} = -200\text{ mV}$, $I_{OL} = -8\text{ mA}$, see Figure 10	0	0.2	0.4	
I_I	Line input current	Other input = 0 V			0.9	mA
			$V_I = 12\text{ V}$			
					-0.7	
I_I	Input current	\overline{RE}	-100		100	μA
R_I	Input resistance	A, B	12			$\text{k}\Omega$
I_{CC}	Supply current (receiver enabled)	A, B, D open, \overline{RE} , DE, and CDE at 0 V			16	mA

† All typical values are at $V_{CC} = 5\text{ V}$ and $T_A = 25^\circ\text{C}$.

switching characteristics over recommended operating conditions

PARAMETER		TEST CONDITIONS	MIN	TYP	MAX	UNIT
t_{PLH}	Propagation delay time, low-to-high level output	$V_{ID} = -3\text{ V to } 3\text{ V}$, See Figure 9	7		16	ns
t_{PHL}	Propagation delay time, high-to-low level output		7		16	ns
t_r	Receiver output rise time		1.3		3	ns
t_f	Receiver output fall time		1.3		3	ns
t_{PZH}	Receiver output enable time to high level	See Figure 10		26	40	ns
t_{PHZ}	Receiver output disable time from high level				40	
t_{PZL}	Receiver output enable time to low level	See Figure 11		29	40	ns
t_{PLZ}	Receiver output enable time to high level				40	
$t_{sk(p)}$	Pulse skew ($ t_{PLH} - t_{PHL} $)				2	ns
$t_{sk(o)}$	Output skew‡				1.5	ns
$t_{sk(pp)}$	Part-to-part skew§				3	ns

‡ Output skew ($t_{sk(o)}$) is the magnitude of the time delay difference between the outputs of a single device with all of the inputs connected together.

§ Part-to-part skew ($t_{sk(pp)}$) is the magnitude of the difference in propagation delay times between any specified terminals of two devices when both devices operate with the same input signals, the same supply voltages, at the same temperature, and have identical packages and test circuits.

SN65LBC171, SN75LBC171 TRIPLE DIFFERENTIAL TRANSCIEVERS

SLLS460A – NOVEMBER 2000 – REVISED FEBRUARY 2001

PARAMETER MEASUREMENT INFORMATION

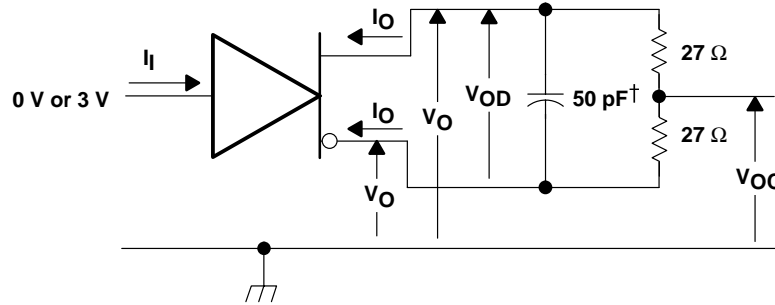

†Includes probe and jig capacitance

Figure 1. Driver Test Circuit, V_{OD} and V_{OC} Without Common-Mode Loading

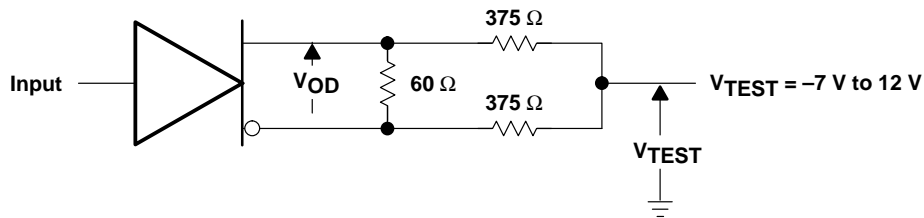
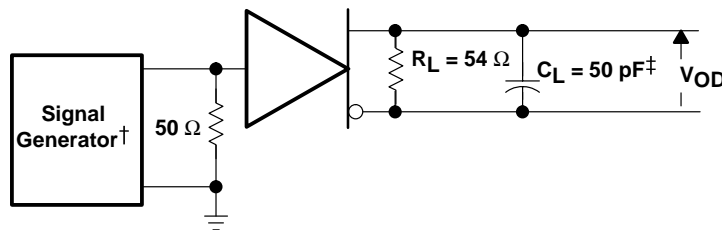

Figure 2. Driver Test Circuit, V_{OD} With Common-Mode Loading



† PRR = 1 MHz, 50% Duty Cycle, $t_r < 6$ ns, $t_f < 6$ ns, $Z_0 = 50 \Omega$

‡ Includes Probe and Jig Capacitance

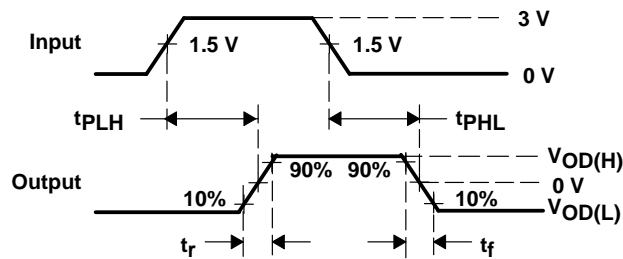
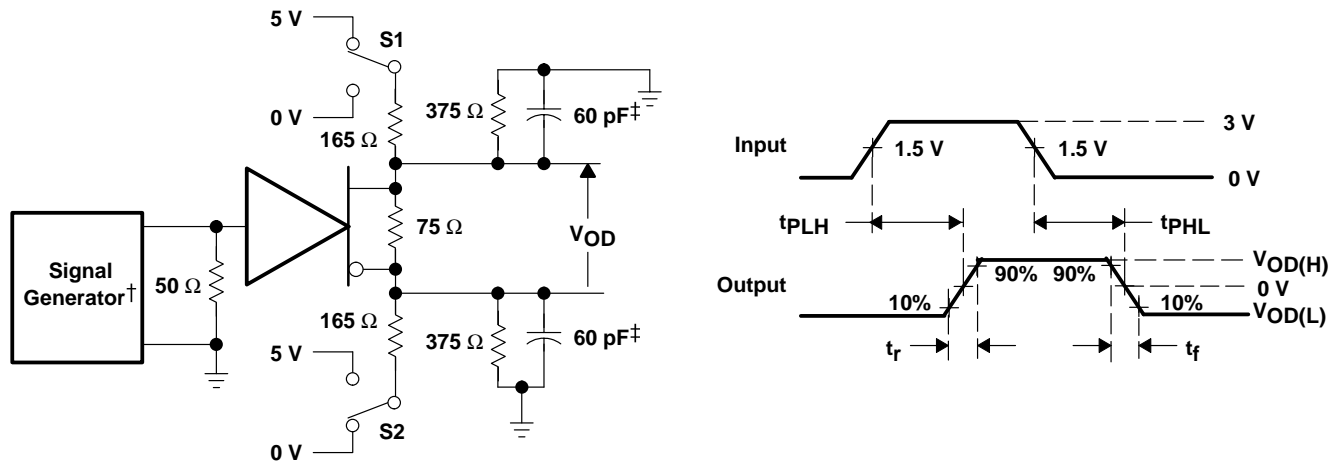

Figure 3. Driver Switching Test Circuit and Waveforms, 485-Loading

PARAMETER MEASUREMENT INFORMATION



† PRR = 1 MHz, 50% Duty Cycle, $t_r < 6$ ns, $t_f < 6$ ns, $Z_0 = 50 \Omega$

‡ Includes Probe and Jig Capacitance

Figure 4. Driver Switching Test Circuit and Waveforms, HVD SCSI-Loading (double terminated)

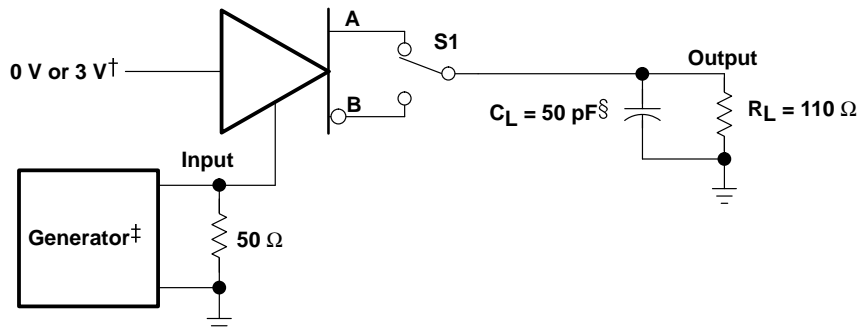

† 3 V if testing A output, 0 V if testing B output

‡ PRR = 1 MHz, 50% Duty Cycle, $t_r < 6$ ns, $t_f < 6$ ns, $Z_0 = 50 \Omega$

§ Includes Probe and Jig Capacitance

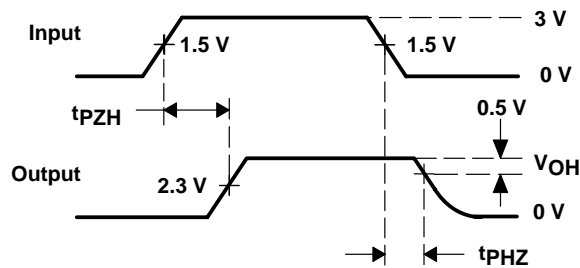
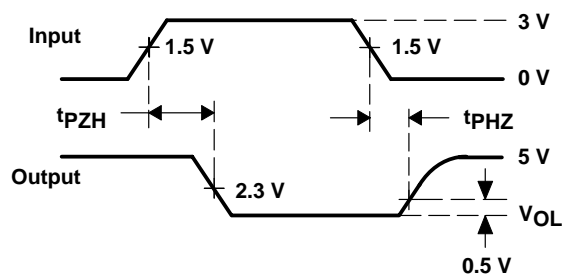
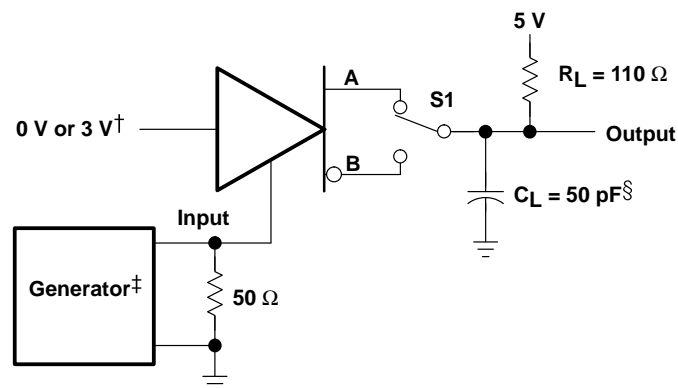

Figure 5. Driver Enable/Disable Test, High Output

SN65LBC171, SN75LBC171 TRIPLE DIFFERENTIAL TRANSCIEVERS

SLLS460A – NOVEMBER 2000 – REVISED FEBRUARY 2001

PARAMETER MEASUREMENT INFORMATION



† 0 V if testing A output, 3 V if testing B output
‡ PRR = 1 MHz, 50% Duty Cycle, $t_r < 6$ ns, $t_f < 6$ ns, $Z_0 = 50 \Omega$
§ Includes Probe and Jig Capacitance

Figure 6. Driver Enable/Disable Test, Low Output

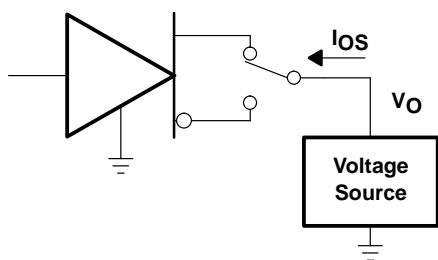

Figure 7. Driver Short-Circuit Test

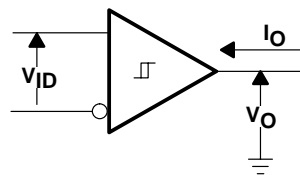
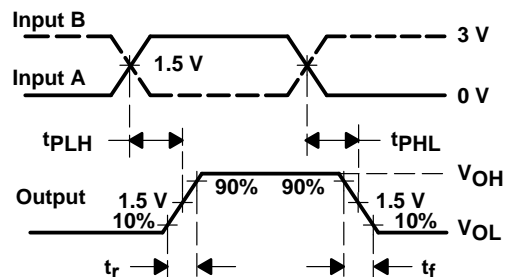
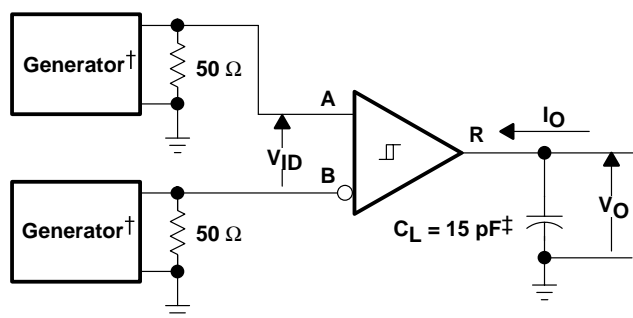

Figure 8. Receiver DC Parameters



† PRR = 1 MHz, 50% Duty Cycle, $t_r < 6$ ns, $t_f < 6$ ns, $Z_0 = 50 \Omega$
‡ Includes Probe and Jig Capacitance

Figure 9. Receiver Switching Test Circuit and Waveforms

PARAMETER MEASUREMENT INFORMATION

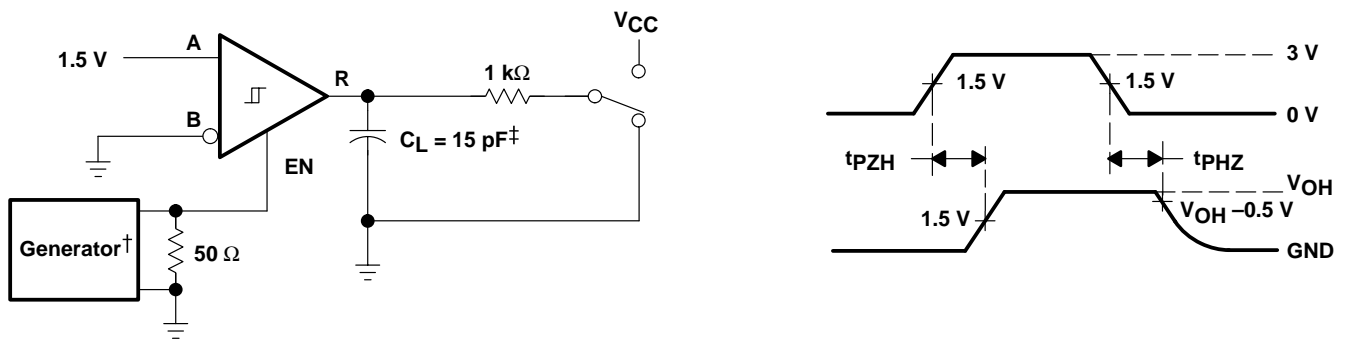

† PRR = 1 MHz, 50% Duty Cycle, $t_r < 6$ ns, $t_f < 6$ ns, $Z_0 = 50 \Omega$
‡ Includes Probe and Jig Capacitance

Figure 10. Receiver Enable/Disable Test, High Output

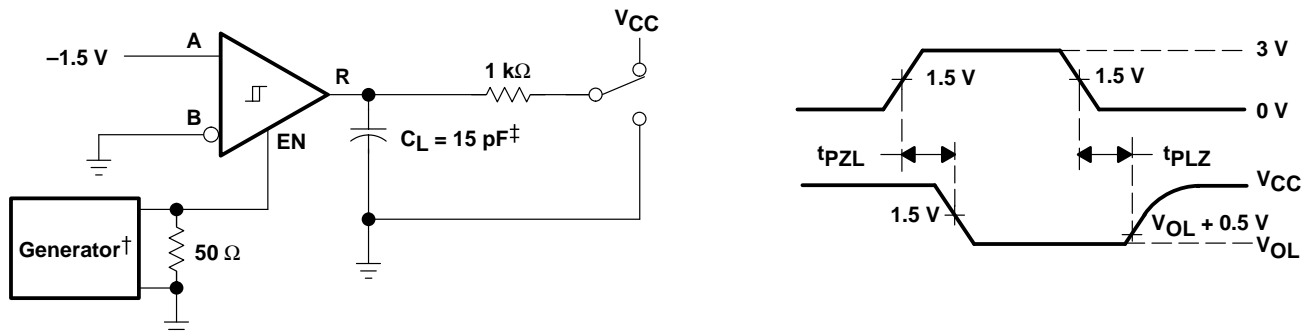

† PRR = 1 MHz, 50% Duty Cycle, $t_r < 6$ ns, $t_f < 6$ ns, $Z_0 = 50 \Omega$
‡ Includes Probe and Jig Capacitance

Figure 11. Receiver Enable/Disable Test, Low Output

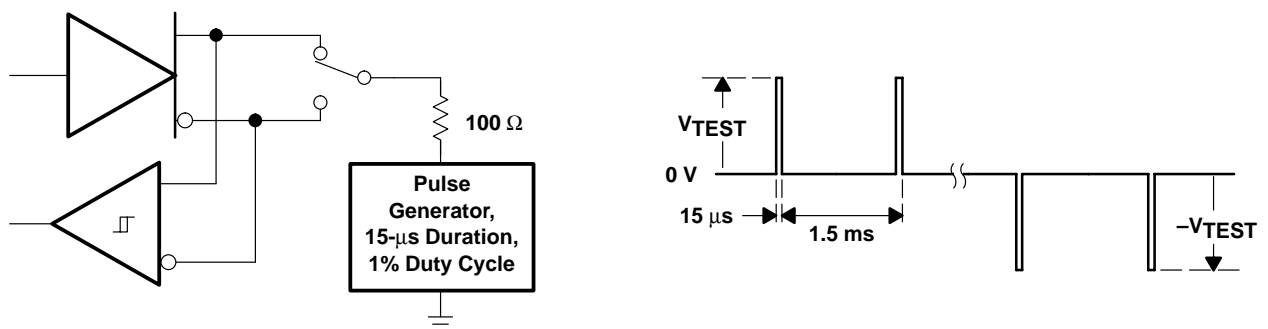

Figure 12. Test Circuit and Waveform, Transient Over Voltage Test

SN65LBC171, SN75LBC171 TRIPLE DIFFERENTIAL TRANSCEIVERS

SLLS460A – NOVEMBER 2000 – REVISED FEBRUARY 2001

TYPICAL CHARACTERISTICS

DIFFERENTIAL OUTPUT VOLTAGE
vs
OUTPUT CURRENT

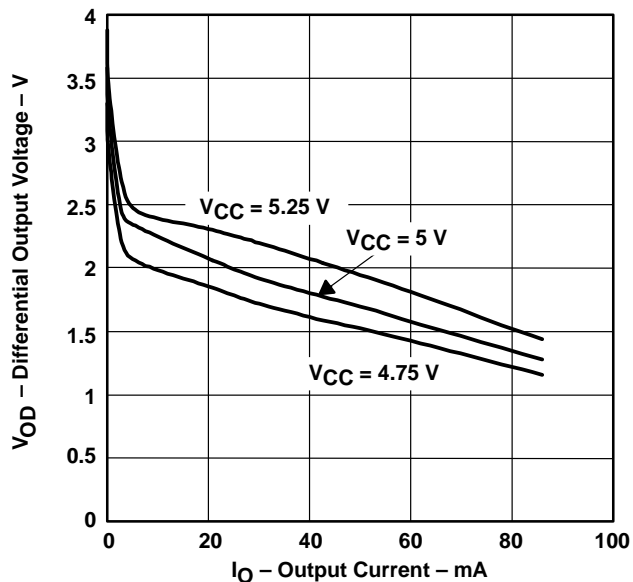

Figure 13

DIFFERENTIAL OUTPUT VOLTAGE
vs
FREE-AIR TEMPERATURE

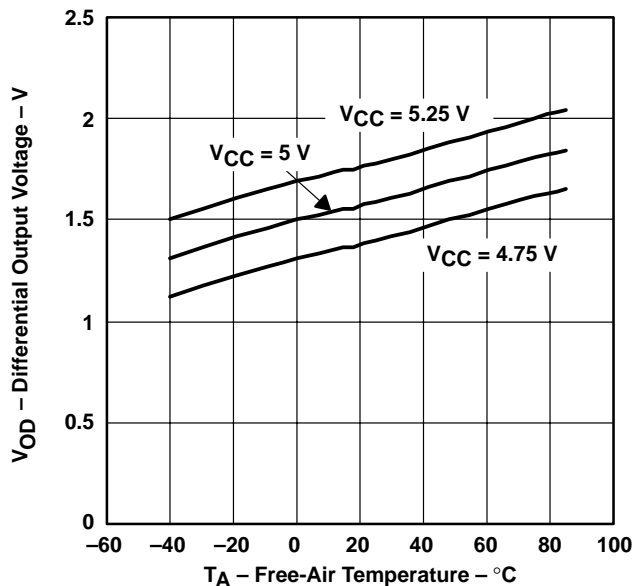

Figure 14

DRIVER PROPAGATION DELAY
vs
FREE-AIR TEMPERATURE

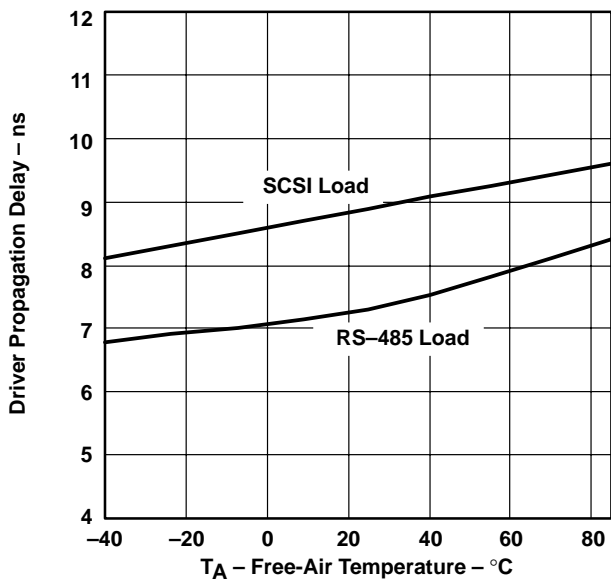

Figure 15

SUPPLY CURRENT
vs
SIGNALLING RATE

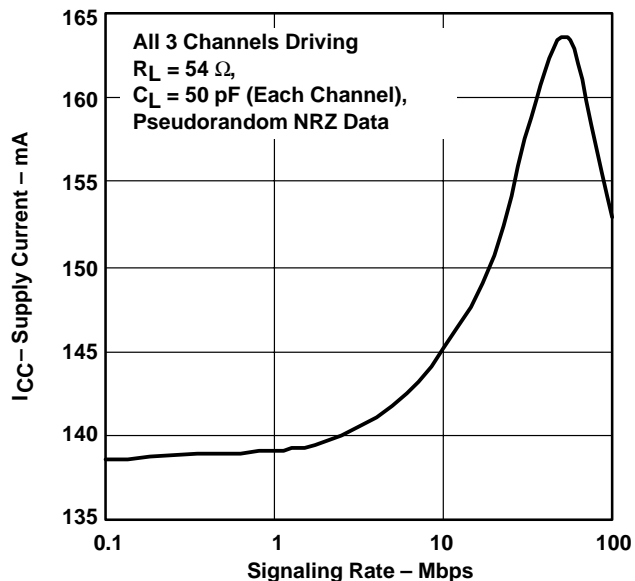

Figure 16



TYPICAL CHARACTERISTICS

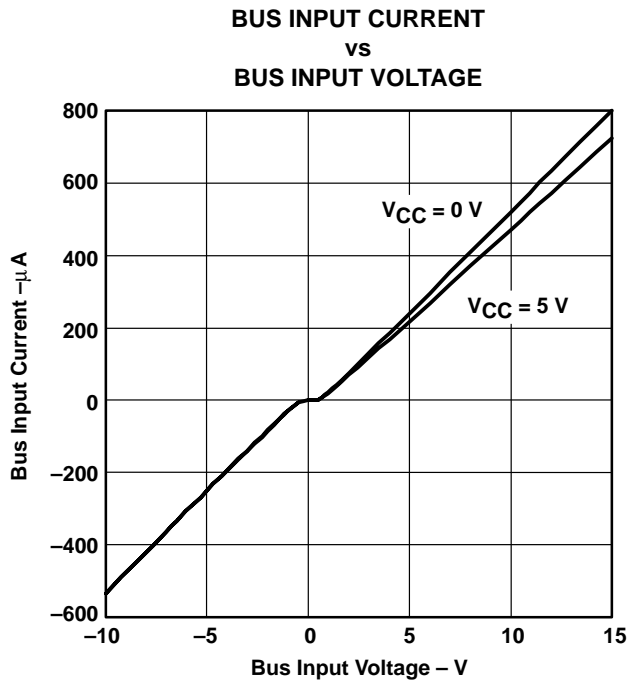

Figure 17

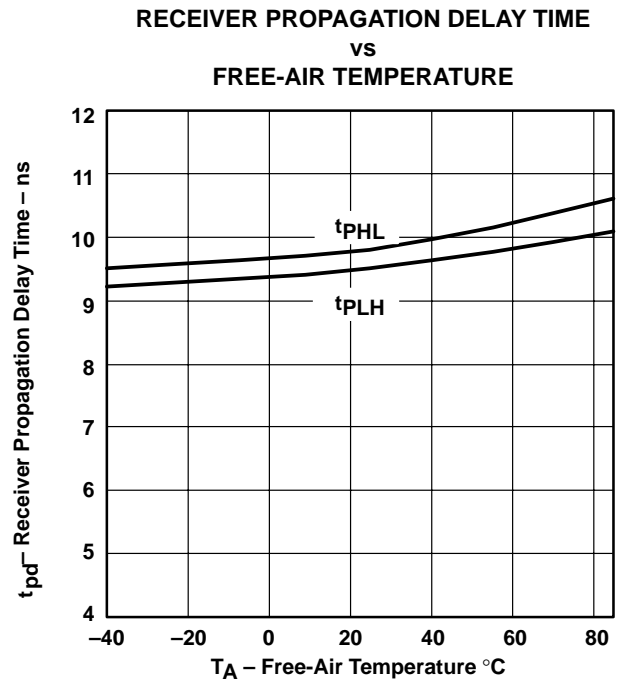

Figure 18

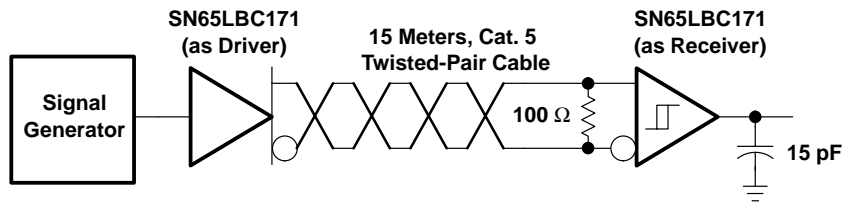

Figure 19. Circuit Diagram for Signaling Characteristics

SN65LBC171, SN75LBC171 TRIPLE DIFFERENTIAL TRANSCEIVERS

SLLS460A – NOVEMBER 2000 – REVISED FEBRUARY 2001

TYPICAL CHARACTERISTICS

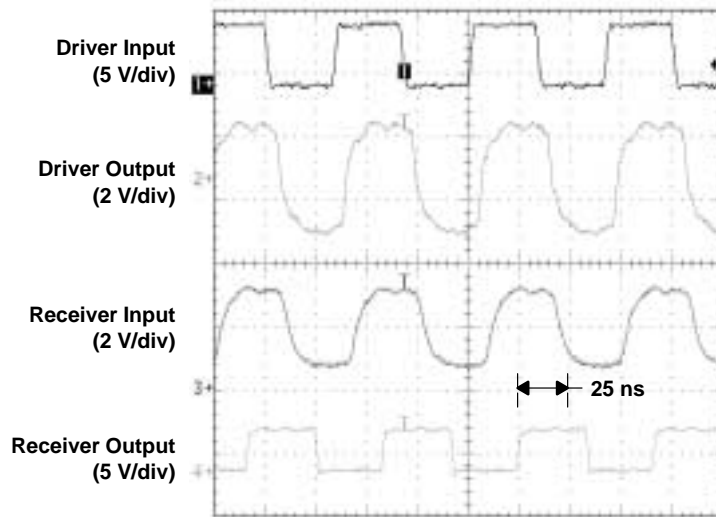

Figure 20. Signal Waveforms at 30 Mbps

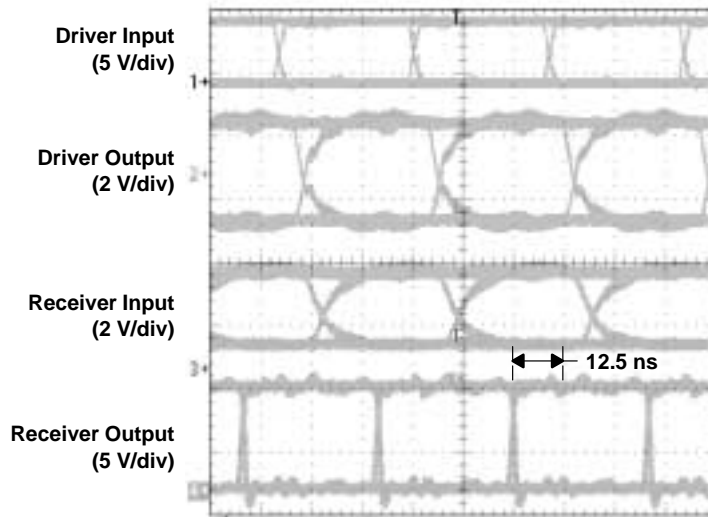

Figure 21. Eye Patterns, Pseudorandom Data at 30 Mbps

TYPICAL CHARACTERISTICS

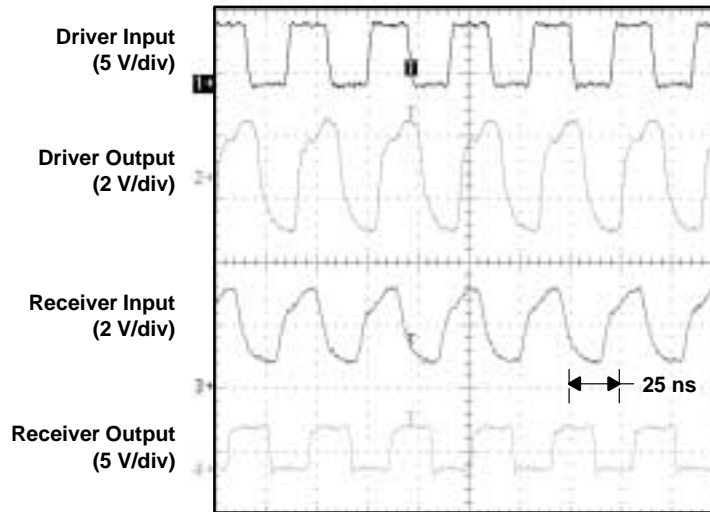

Figure 22. Signal Waveforms at 50 Mbps

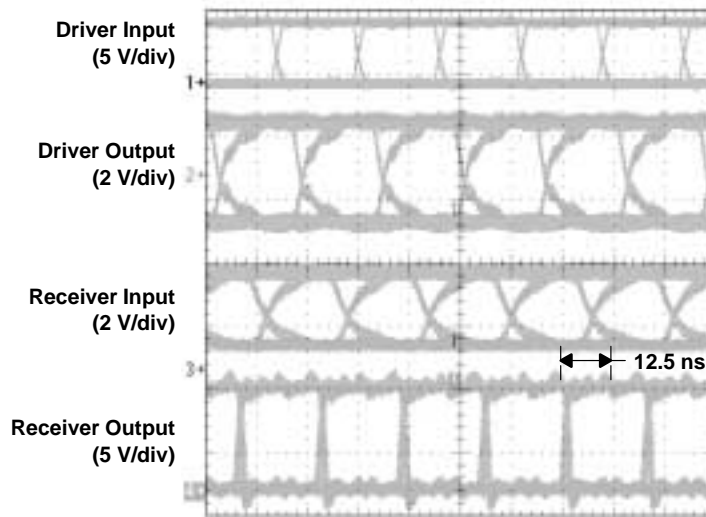

Figure 23. Eye Patterns, Pseudorandom Data at 50 Mbps

SN65LBC171, SN75LBC171 TRIPLE DIFFERENTIAL TRANSCEIVERS

SLLS460A – NOVEMBER 2000 – REVISED FEBRUARY 2001

MECHANICAL DATA

DB (R-PDSO-G**)

PLASTIC SMALL-OUTLINE

28 PINS SHOWN

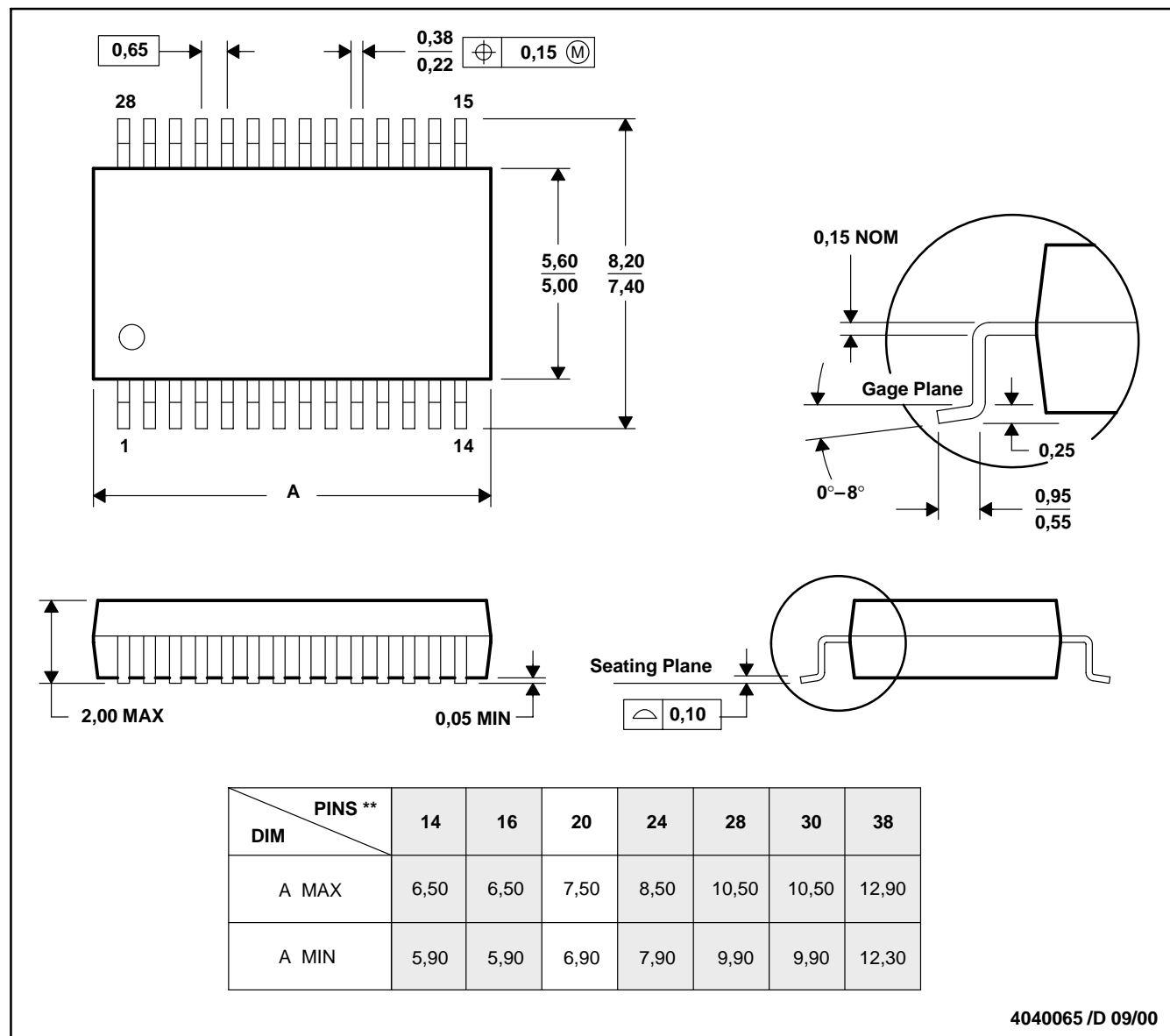

- NOTES: A. All linear dimensions are in millimeters.
 B. This drawing is subject to change without notice.
 C. Body dimensions do not include mold flash or protrusion not to exceed 0,15.
 D. Falls within JEDEC MO-150

SN65LBC171, SN75LBC171 TRIPLE DIFFERENTIAL TRANSCEIVERS

SLLS460A – NOVEMBER 2000 – REVISED FEBRUARY 2001

MECHANICAL DATA

DW (R-PDSO-G**)

PLASTIC SMALL-OUTLINE PACKAGE

16 PINS SHOWN

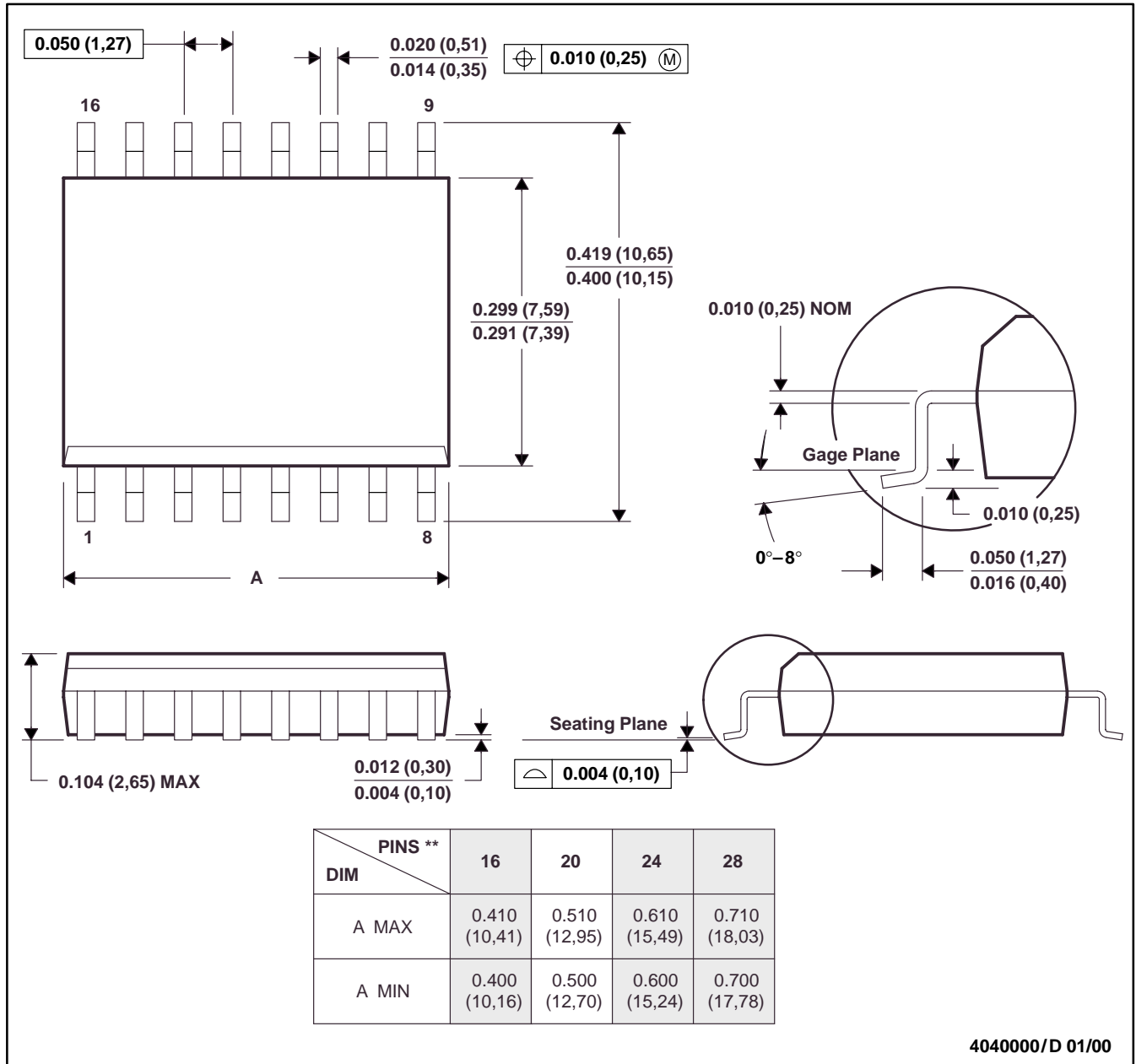

- NOTES: A. All linear dimensions are in inches (millimeters).
 B. This drawing is subject to change without notice.
 C. Body dimensions do not include mold flash or protrusion not to exceed 0.006 (0,15).
 D. Falls within JEDEC MS-013

PACKAGING INFORMATION

Orderable Device	Status (1)	Package Type	Package Drawing	Pins	Package Qty	Eco Plan (2)	Lead finish/ Ball material (6)	MSL Peak Temp (3)	Op Temp (°C)	Device Marking (4/5)	Samples
SN65LBC171DB	ACTIVE	SSOP	DB	20	70	RoHS & Green	NIPDAU	Level-1-260C-UNLIM	-40 to 85	BL171	Samples
SN65LBC171DW	ACTIVE	SOIC	DW	20	25	RoHS & Green	NIPDAU	Level-1-260C-UNLIM	-40 to 85	65LBC171	Samples
SN65LBC171DWR	ACTIVE	SOIC	DW	20	2000	RoHS & Green	NIPDAU	Level-1-260C-UNLIM	-40 to 85	65LBC171	Samples
SN75LBC171DB	ACTIVE	SSOP	DB	20	70	RoHS & Green	NIPDAU	Level-1-260C-UNLIM	0 to 70	LB171	Samples

(1) The marketing status values are defined as follows:

ACTIVE: Product device recommended for new designs.

LIFEBUY: TI has announced that the device will be discontinued, and a lifetime-buy period is in effect.

NRND: Not recommended for new designs. Device is in production to support existing customers, but TI does not recommend using this part in a new design.

PREVIEW: Device has been announced but is not in production. Samples may or may not be available.

OBSELETE: TI has discontinued the production of the device.

(2) **RoHS:** TI defines "RoHS" to mean semiconductor products that are compliant with the current EU RoHS requirements for all 10 RoHS substances, including the requirement that RoHS substance do not exceed 0.1% by weight in homogeneous materials. Where designed to be soldered at high temperatures, "RoHS" products are suitable for use in specified lead-free processes. TI may reference these types of products as "Pb-Free".

RoHS Exempt: TI defines "RoHS Exempt" to mean products that contain lead but are compliant with EU RoHS pursuant to a specific EU RoHS exemption.

Green: TI defines "Green" to mean the content of Chlorine (Cl) and Bromine (Br) based flame retardants meet JS709B low halogen requirements of <=1000ppm threshold. Antimony trioxide based flame retardants must also meet the <=1000ppm threshold requirement.

(3) MSL, Peak Temp. - The Moisture Sensitivity Level rating according to the JEDEC industry standard classifications, and peak solder temperature.

(4) There may be additional marking, which relates to the logo, the lot trace code information, or the environmental category on the device.

(5) Multiple Device Markings will be inside parentheses. Only one Device Marking contained in parentheses and separated by a "-" will appear on a device. If a line is indented then it is a continuation of the previous line and the two combined represent the entire Device Marking for that device.

(6) Lead finish/Ball material - Orderable Devices may have multiple material finish options. Finish options are separated by a vertical ruled line. Lead finish/Ball material values may wrap to two lines if the finish value exceeds the maximum column width.

Important Information and Disclaimer:The information provided on this page represents TI's knowledge and belief as of the date that it is provided. TI bases its knowledge and belief on information provided by third parties, and makes no representation or warranty as to the accuracy of such information. Efforts are underway to better integrate information from third parties. TI has taken and

continues to take reasonable steps to provide representative and accurate information but may not have conducted destructive testing or chemical analysis on incoming materials and chemicals. TI and TI suppliers consider certain information to be proprietary, and thus CAS numbers and other limited information may not be available for release.

In no event shall TI's liability arising out of such information exceed the total purchase price of the TI part(s) at issue in this document sold by TI to Customer on an annual basis.

TAPE AND REEL INFORMATION

QUADRANT ASSIGNMENTS FOR PIN 1 ORIENTATION IN TAPE



*All dimensions are nominal

Device	Package Type	Package Drawing	Pins	SPQ	Reel Diameter (mm)	Reel Width W1 (mm)	A0 (mm)	B0 (mm)	K0 (mm)	P1 (mm)	W (mm)	Pin1 Quadrant
SN65LBC171DWR	SOIC	DW	20	2000	330.0	24.4	10.8	13.3	2.7	12.0	24.0	Q1

TAPE AND REEL BOX DIMENSIONS

*All dimensions are nominal

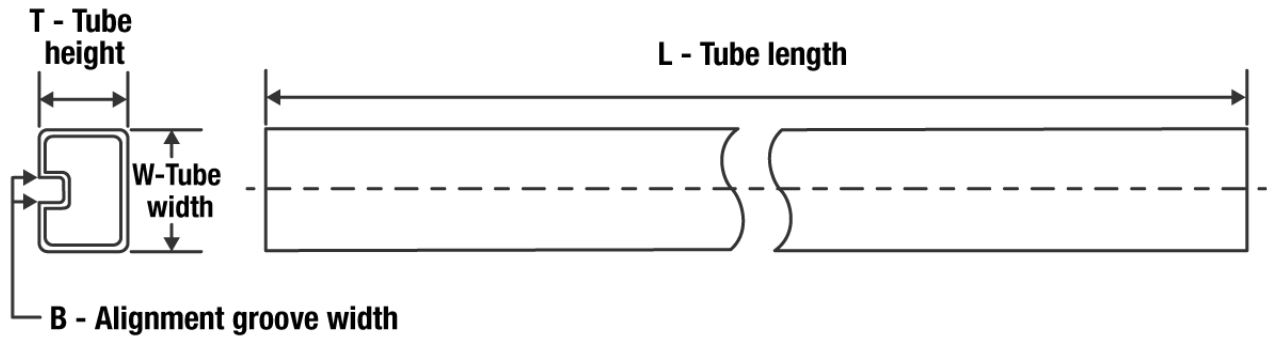
Device	Package Type	Package Drawing	Pins	SPQ	Length (mm)	Width (mm)	Height (mm)
SN65LBC171DWR	SOIC	DW	20	2000	367.0	367.0	45.0

TUBE

*All dimensions are nominal

Device	Package Name	Package Type	Pins	SPQ	L (mm)	W (mm)	T (μm)	B (mm)
SN65LBC171DB	DB	SSOP	20	70	530	10.5	4000	4.1
SN65LBC171DW	DW	SOIC	20	25	507	12.83	5080	6.6
SN75LBC171DB	DB	SSOP	20	70	530	10.5	4000	4.1

IMPORTANT NOTICE AND DISCLAIMER

TI PROVIDES TECHNICAL AND RELIABILITY DATA (INCLUDING DATA SHEETS), DESIGN RESOURCES (INCLUDING REFERENCE DESIGNS), APPLICATION OR OTHER DESIGN ADVICE, WEB TOOLS, SAFETY INFORMATION, AND OTHER RESOURCES "AS IS" AND WITH ALL FAULTS, AND DISCLAIMS ALL WARRANTIES, EXPRESS AND IMPLIED, INCLUDING WITHOUT LIMITATION ANY IMPLIED WARRANTIES OF MERCHANTABILITY, FITNESS FOR A PARTICULAR PURPOSE OR NON-INFRINGEMENT OF THIRD PARTY INTELLECTUAL PROPERTY RIGHTS.

These resources are intended for skilled developers designing with TI products. You are solely responsible for (1) selecting the appropriate TI products for your application, (2) designing, validating and testing your application, and (3) ensuring your application meets applicable standards, and any other safety, security, regulatory or other requirements.

These resources are subject to change without notice. TI grants you permission to use these resources only for development of an application that uses the TI products described in the resource. Other reproduction and display of these resources is prohibited. No license is granted to any other TI intellectual property right or to any third party intellectual property right. TI disclaims responsibility for, and you will fully indemnify TI and its representatives against, any claims, damages, costs, losses, and liabilities arising out of your use of these resources.

TI's products are provided subject to [TI's Terms of Sale](#) or other applicable terms available either on ti.com or provided in conjunction with such TI products. TI's provision of these resources does not expand or otherwise alter TI's applicable warranties or warranty disclaimers for TI products.

TI objects to and rejects any additional or different terms you may have proposed.

Mailing Address: Texas Instruments, Post Office Box 655303, Dallas, Texas 75265
Copyright © 2022, Texas Instruments Incorporated