

TDC1000 用于液位感测、流量感测、浓度感测以及接近传感应用的超声波感测模拟前端 (AFE)

1 特性

- 符合汽车级 AEC-Q100 标准 (TDC1000-Q1)
- 测量范围: 高达 8ms
- 工作电流: 1.8 μ A (2 SPS)
- 发送器通道 TX1/TX2:
 - 支持单传感器或双传感器应用
 - 可编程激励: 31.25kHz 至 4MHz, 多达 31 个脉冲
- 接收器通道 RX1/RX2:
 - STOP 逐周期抖动: 50ps_{RMS}
 - 低噪声、可编程增益放大器
 - 可访问外部滤波器的信号链设计
 - 针对回声质检的可编程阈值比较器
 - 针对差动飞行时间 (TOF) 测量自动交换通道
 - 针对较长 TOF 测量的可编程低功耗模式
- 温度测量
 - 2 个 PT1000/500 RTD 接口
 - RTD 间的匹配精度为 0.02°C_{RMS}
- 工作温度范围: -40°C 至 125°C

2 应用范围

- 不同材料箱中的各项测量:
 - 液位
 - 液体鉴别/浓度
- 流量计量: 水、气体、热量
- 远距/接近传感

3 说明

TDC1000 是一款完全集成的超声波感测模拟前端 (AFE), 常用于汽车、工业、医疗和消费品市场中的液位、液体鉴别/浓度、流量以及接近传感/远距感测应用。与 MSP430/C2000 MCU、电源、无线网络和源代码配套使用时, TI 可提供完整的超声波感测解决方案。

TI 的超声波 AFE 可编程且具有灵活性, 可适应广泛的应用和终端设备。TDC1000 可针对多种发射脉冲和频率、增益和信号阈值进行配置, 以便在多种传感器频率 (31.25kHz 至 4MHz) 和 Q 系数下使用。同样, 接收路径可编程设定, 因此在更远的距离/更大的箱体尺寸范围内也能够检测到通过多种介质传播的超声波。

TDC1000 可选择不同的工作模式, 并且针对低功耗进行了优化,

这使得它成为电池供电流量计,

液位测量仪以及距离/接近传感测量装置的理想选择。

低噪声放大器和比较器产生的抖动极低, 可实现零流量和低流量测量的皮秒级分辨率和精度。

器件信息⁽¹⁾

部件号	封装	封装尺寸 (标称值)
TDC1000	TSSOP (28) PW	9.70mm x 4.40mm
TDC1000-Q1	TSSOP (28) PW	9.70mm x 4.40mm

(1) 要了解所有可用封装, 请见数据表末尾的可订购产品附录。

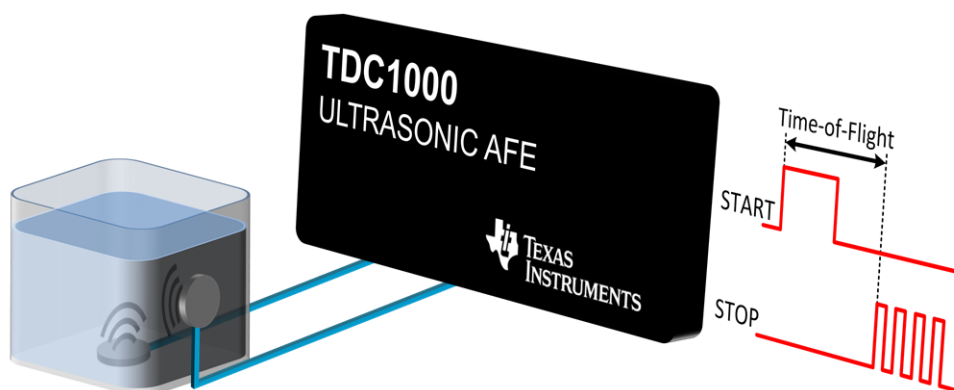

目录

1	特性	1	8.4	Device Functional Modes	20
2	应用范围	1	8.5	Programming	31
3	说明	1	8.6	Register Maps	32
4	修订历史记录	2	9	Application and Implementation	41
5	Pin Configuration and Functions	3	9.1	Application Information	41
6	Specifications	4	9.2	Typical Applications	41
6.1	Absolute Maximum Ratings	4	10	Power Supply Recommendations	51
6.2	ESD Ratings	4	11	Layout	52
6.3	Recommended Operating Conditions	4	11.1	Layout Guidelines	52
6.4	Thermal Information	5	11.2	Layout Example	52
6.5	Electrical Characteristics	6	12	器件和文档支持	53
6.6	Timing Requirements	8	12.1	器件支持	53
6.7	Switching Characteristics	8	12.2	文档支持	53
6.8	Typical Characteristics	9	12.3	相关链接	53
7	Parameter Measurement Information	11	12.4	社区资源	53
8	Detailed Description	12	12.5	商标	53
8.1	Overview	12	12.6	静电放电警告	53
8.2	Functional Block Diagram	12	12.7	Glossary	53
8.3	Feature Description	13	13	机械、封装和可订购信息	54

4 修订历史记录

注意：前一修订版的页码可能与当前版本的页码不同。

Changes from Revision A (December 2014) to Revision B	Page
• 已添加 整个文档中 PW 封装的命名法	1
• Changed programmed threshold in Figure 35 , Multiple Echo Receive Mode (Zoom-in)	25
• Added trigger to START time description	26
• Changed notes on Figure 37 , Short TOF Measurement	27
• Changed note A on Figure 38 , Standard TOF Measurement	28
• Changed note A on Figure 39 , Standard TOF Measurement with Blanking Enabled	29
• Changed Equation 9 , downstream TOF	48

Changes from Original (October 2014) to Revision A	Page
• 已添加 引脚配置和功能部分，规范部分，参数测量信息部分，详细说明部分，应用和实施部分，电源相关建议部分以及布局部分	1
• 已更改 器件和文档支持部分	1

5 Pin Configuration and Functions

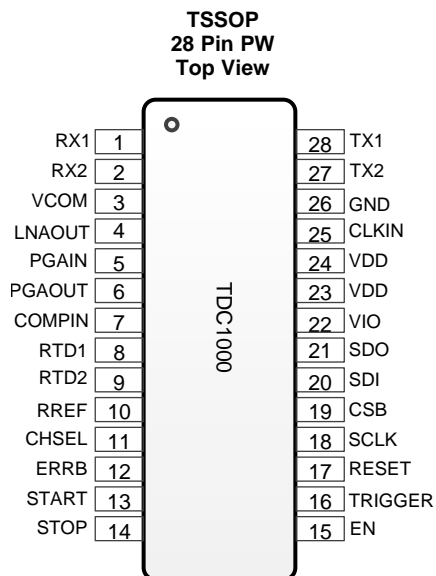

Pin Functions

PIN		TYPE ⁽¹⁾	DESCRIPTION
NAME	NO.		
RX1	1	I	Receive input 1
RX2	2	I	Receive input 2
VCOM	3	P	Output common mode voltage bias
LNAOUT	4	O	Low noise amplifier output (for ac decoupling capacitor)
PGAIN	5	I	Programmable gain amplifier input
PGAOUT	6	O	Programmable gain amplifier output
COMPIN	7	I	Echo qualification and zero-crossing detector input
RTD1	8	O	Resistance temperature detector channel 1
RTD2	9	O	Resistance temperature detector channel 2
RREF	10	O	Reference resistor for temperature measurement
CHSEL	11	I	External channel selection
ERRB	12	O	Error flag (open drain)
START	13	O	Start pulse output
STOP	14	O	Stop pulse output
EN	15	I	Enable (active high; when low the TDC1000 is in SLEEP mode)
TRIGGER	16	I	Trigger input
RESET	17	I	Reset (active high)
SCLK	18	I	Serial clock for the SPI interface
CSB	19	I	Chip select for the SPI interface (active low)
SDI	20	I	Serial data input for the SPI interface
SDO	21	O	Serial data output for the SPI interface
VIO	22	P	Positive I/O supply
VDD ⁽²⁾	23, 24	P	Positive supply; all VDD supply pins must be connected to the supply.
CLKIN	25	I	Clock input
GND	26	G	Negative supply

(1) G = Ground, I = Input, O = Output, P = Power

(2) Place a 100-nF bypass capacitor to ground in closest proximity of the pin

Pin Functions (continued)

PIN		TYPE ⁽¹⁾	DESCRIPTION
NAME	NO.		
TX2	27	O	Transmit output 2
TX1	28	O	Transmit output 1

6 Specifications

6.1 Absolute Maximum Ratings

 Over operating free-air temperature range (unless otherwise noted) ⁽¹⁾⁽²⁾

		MIN	MAX	UNIT
V _{DD}	Analog supply voltage, VDD pins	−0.3	6.0	V
V _{IO}	I/O supply voltage (V _{IO} must always be lower than or equal to V _{DD} supply)	−0.3	6.0	V
V _I	Voltage on any analog input pin ⁽³⁾	−0.3	V _{DD} + 0.3	V
V _I	Voltage on any digital input pin ⁽³⁾	−0.3	V _{IO} + 0.3	V
I _I	Input current at any pin		5	mA
T _J	Operating junction temperature	−40	125	°C
T _{stg}	Storage temperature range	−65	150	°C

(1) Stresses beyond those listed under *Absolute Maximum Ratings* may cause permanent damage to the device. These are stress ratings only, which do not imply functional operation of the device at these or any other conditions beyond those indicated under *Recommended Operating Conditions*. Exposure to absolute-maximum-rated conditions for extended periods may affect device reliability.

(2) All voltages are with respect to ground, unless otherwise specified.

(3) When the input voltage at a pin exceeds the power supplies, the current at that pin must not exceed 5 mA and the voltage (V_I) at that pin must not exceed 6.0 V.

6.2 ESD Ratings

		VALUE	UNIT	
V _(ESD)	Electrostatic discharge	Human-body model (HBM), per AEC A100-002 ⁽¹⁾	±2000	
		Charged-device model (CDM), per AEC Q100-011	All pins	±500
			Corner pins (1, 14, 15 and 28)	±750

(1) AEC Q100-002 indicates HBM stressing is done in accordance with the ANSI/ESDA/JEDEC JS-001 specification.

6.3 Recommended Operating Conditions

Over operating free-air temperature range (unless otherwise noted)

		MIN	MAX	UNIT
V _{DD}	Analog supply voltage, VDD pins	2.7	5.5	V
V _{IO}	Digital supply voltage, (V _{IO} must always be lower than or equal to V _{DD} supply)	1.8	V _{DD}	V
V _I	Voltage on any analog input pin	GND	V _{DD}	V
V _I	Voltage on any digital input pin	GND	V _{IO}	V
f _{CLKIN}	Operating frequency	0.06	16	MHz
T _J	Operating junction temperature	−40	125	°C

6.4 Thermal Information⁽¹⁾

THERMAL METRIC		TDC1000 TSSOP (28 PINS) PW	UNIT
$R_{\theta JA}$	Junction-to-ambient thermal resistance	83.5	°C/W
$R_{\theta JC(top)}$	Junction-to-case (top) thermal resistance	29.9	
$R_{\theta JB}$	Junction-to-board thermal resistance	40.8	
Ψ_{JT}	Junction-to-top characterization parameter	2.4	
Ψ_{JB}	Junction-to-board characterization parameter	40.3	

(1) For more information about traditional and new thermal metrics, see the *IC Package Thermal Metrics* application report, [SPRA953](#).

6.5 Electrical Characteristics

The electrical ratings specified in this section apply to all specifications in this document, unless otherwise noted. These specifications are interpreted as conditions that do not degrade the device parametric or functional specifications for the life of the product containing it. $T_A = 25^\circ\text{C}$, $V_{DD} = V_{IO} = 3.7\text{ V}$, $V_{COM} = V_{CM} = V_{DD} / 2$, $C_{VCOM} = 10\text{ nF}$ (unless otherwise noted).

PARAMETER		TEST CONDITIONS		MIN	TYP	MAX	UNIT
TRANSMITTER SIGNAL PATH (TX)							
$V_{OUT(TX)}$	Output voltage swing	$f_{out} = 1\text{ MHz}$, $R_L = 75\ \Omega$ to V_{CM}	HIGH	$V_{DD} - 0.32$			V
			LOW	0.32			V
$I_{OUT(TX)}$	Output drive current	$f_{out} = 1\text{ MHz}$, $R_L = 75\ \Omega$ to V_{CM}		22			mA_{RMS}
$f_{OUT(TX)}$	Output TX frequency	$f_{CLKIN} = 8\text{ MHz}$, divide-by-2 (programmable; see Transmitter Signal Path)		4			MHz
RECEIVER SIGNAL PATH (RX)							
Δt_{STOP}	STOP cycle-to-cycle jitter	LNA capacitive feedback, $G_{PGA} = 6\text{ dB}$, $f_{IN} = 1\text{ MHz}$, $V_{IN} = 100\text{ mV}_{PP}$, $C_{VCOM} = 1\ \mu\text{F}$ and Figure 14		50			pS_{RMS}
LNA							
G_{LNA}	LNA gain	Capacitive feedback, $C_{IN} = 300\text{ pF}$, $f_{IN} = 1\text{ MHz}$, $R_L = 100\text{ k}\Omega$ to V_{CM} , $C_{VCOM} = 1\ \mu\text{F}$		20			dB
en_{LNA}	LNA input referred noise density	Capacitive feedback, $C_{IN} = 300\text{ pF}$, $f = 1\text{ MHz}$, $V_{DD} = 3.1\text{ V}$, $V_{IN} = V_{CM}$, $R_L = \infty$, $C_{VCOM} = 1\ \mu\text{F}$		2			$\text{nV}/\sqrt{\text{Hz}}$
$V_{IN(LNA)}$	Input voltage range	Resistive feedback, $R_L = 1\text{ k}\Omega$ to V_{CM} , $C_{VCOM} = 1\ \mu\text{F}$	HIGH	$V_{CM} + (V_{CM} - 0.24) / (G_{LNA})$			V
			LOW	$V_{CM} - (V_{CM} - 0.24) / (G_{LNA})$			V
$V_{OUT(LNA)}$	Output voltage range	Resistive feedback, $R_L = 1\text{ k}\Omega$ to V_{CM} , $C_{VCOM} = 1\ \mu\text{F}$	HIGH	$V_{DD} - 0.24$			V
			LOW	$\text{GND} + 0.24$			V
SR_{LNA}	Slew rate ⁽¹⁾	Resistive feedback, $R_L = 1\text{ k}\Omega$ to V_{CM} , 100mV step, $C_{VCOM} = 1\ \mu\text{F}$		9			$\text{V}/\mu\text{s}$
XTK	MUX ch-to-ch crosstalk	Capacitive feedback, $f = 1\text{ MHz}$, $R_L = 100\text{ k}\Omega$ to V_{CM} , $C_{VCOM} = 1\ \mu\text{F}$		-57			dB
BW_{LNA}	-3-dB bandwidth	Capacitive feedback, $C_{IN} = 300\text{ pF}$, $R_L = 100\text{ k}\Omega$ to V_{CM} , $C_{VCOM} = 1\ \mu\text{F}$		5			MHz
$V_{OS(LNA)}$	LNA input offset voltage	Resistive mode, $V_{IN} = V_{CM}$, $R_L = \infty$		± 320			μV
VCOM							
V_{COM}	VCOM output voltage	$C_{VCOM} = 1\ \mu\text{F}$		V_{CM}			V
	VCOM output error			0.5%			
PGA							
$V_{IN(PGA)}$	PGA input range	$R_L = 100\text{ k}\Omega$ to V_{CM} , $C_L = 10\text{ pF}$ to GND	HIGH	$V_{CM} + (V_{CM} - 0.06) / (G_{PGA})$			V
			LOW	$V_{CM} - (V_{CM} - 0.06) / (G_{PGA})$			V
G_{PGAMIN}	PGA min gain	DC, $R_L = \infty$, $C_L = 10\text{ pF}$		0			dB
G_{PGAMAX}	PGA max gain			21			dB
ΔG_{PGA}	PGA gain step size			3			dB
$G_E(PGA)$	PGA gain error	DC, $G_{PGA} = 0\text{ dB}$, $R_L = \infty$, $C_L = 10\text{ pF}$		5%			
TCG_{PGA}	PGA gain temperature coefficient	DC, $G_{PGA} = 0\text{ dB}$, $R_L = \infty$, $C_L = 10\text{ pF}$		170			$\text{ppm}/^\circ\text{C}$
en_{PGA}	PGA input referred noise density	$G_{PGA} = 21\text{ dB}$, $f = 1\text{ MHz}$, $V_{DD} = 3.1\text{ V}$, $V_{IN} = V_{CM}$, $R_L = \infty$, $C_{VCOM} = 1\ \mu\text{F}$		3.1			$\text{nV}/\sqrt{\text{Hz}}$
$V_{OUT(PGA)}$	Output range	$R_L = 100\text{ k}\Omega$ to V_{CM} , $C_L = 10\text{ pF}$ to GND	HIGH	$V_{DD} - 0.06$			V
			LOW	60			mV
BW_{PGA}	-3-dB bandwidth	$G_{PGA} = 21\text{ dB}$, $R_L = 100\text{ k}\Omega$ to V_{CM} , $C_L = 10\text{ pF}$, $C_{VCOM} = 1\ \mu\text{F}$		5			MHz
SR_{PGA}	Slew rate ⁽¹⁾	$G_{PGA} = 21\text{ dB}$, $R_L = 100\text{ k}\Omega$ to V_{CM} , $C_L = 10\text{ pF}$, $C_{VCOM} = 1\ \mu\text{F}$		12.5			$\text{V}/\mu\text{s}$

(1) The slew rate is measured from 10% to 90% and is represented by the average of the rising and falling slew rates.

Electrical Characteristics (continued)

The electrical ratings specified in this section apply to all specifications in this document, unless otherwise noted. These specifications are interpreted as conditions that do not degrade the device parametric or functional specifications for the life of the product containing it. $T_A = 25^\circ\text{C}$, $V_{DD} = V_{IO} = 3.7\text{ V}$, $V_{COM} = V_{CM} = V_{DD} / 2$, $C_{VCOM} = 10\text{ nF}$ (unless otherwise noted).

PARAMETER		TEST CONDITIONS	MIN	TYP	MAX	UNIT
ZERO CROSS COMPARATOR						
$V_{OS(Comp)}$	Input offset voltage ⁽²⁾	Referred to V_{COM}		±115		µV
en_{COMP}	Zero crossing comparator input referred noise ⁽²⁾	1 MHz		5		nV/√Hz
$HYST_{COMP}$	Hysteresis ⁽²⁾	Referred to V_{COM}		-10		mV
THRESHOLD DETECTOR						
V_{THDET}	Threshold level	ECHO_QUAL_THLD = 0h, V_{COM} referred		-35		mV
		ECHO_QUAL_THLD = 7h, V_{COM} referred		-1.5		V
TEMPERATURE SENSOR INTERFACE⁽³⁾						
T_{ERROR}	Temperature measurement accuracy	$R_{REF} = 1\text{ k}\Omega$, PT1000 range: -40 to 125°C ⁽⁴⁾		1		°C
		$R_{REF} = 1\text{ k}\Omega$, PT1000 range: -15°C to 85°C ⁽⁴⁾		0.5		°C
	Relative accuracy	$R_{REF} = 1\text{ k}\Omega$, $R_{RTD1} = R_{RTD2} = 1.1\text{ k}\Omega$		0.02		°C _{RMS}
TG_E	Gain error			5.8		m°C/°C
POWER SUPPLY						
I_{DD}	VDD supply current	Sleep (EN = CLKIN = TRIGGER = low)		0.61		µA
		Continuous receive mode, LNA and PGA bypassed		2.8	3	mA
		Continuous receive mode, LNA and PGA active		6.2	7.5	mA
		Temp. measurement only (PT1000 mode) ⁽⁵⁾		370	400	µA
		Temp. measurement (PT500 mode) ⁽⁶⁾		500	540	µA
I_{IO}	VIO supply sleep current ⁽²⁾	Sleep (EN = CLKIN = TRIGGER = low)		2		nA
DIGITAL INPUT/OUTPUT CHARACTERISTICS						
V_{IL}	Input logic low threshold			$0.2 \times V_{IO}$		V
V_{IH}	Input logic high threshold		$0.8 \times V_{IO}$			V
V_{OL}	Output logic low threshold	SDO pin, 100-µA current			0.2	V
		SDO pin, 1.85-mA current			0.4	V
		START and STOP pins, 100-µA current			0.5	V
		START and STOP pins, 1.85-mA current			0.6	V
		ERRB pin, 100-µA current			0.2	V
		ERRB pin, 1.85-mA current			0.4	V
V_{OH}	Output logic high threshold	SDO pin, 100-µA current	$V_{IO} - 0.2$			V
		SDO pin, 1.85-mA current	$V_{IO} - 0.6$			V
		START and STOP pins, 100-µA current	$V_{IO} - 0.5$			V
		START and STOP pins, 1.85-mA current	$V_{IO} - 0.6$			V
		ERRB pin, 0-µA current	$V_{IO} - 0.2$			V
I_{OMAX}	Maximum output current for SDO, START and STOP			1.85		mA

(2) Specified by design.

(3) With ideal external components. For more detail see *Temp Sensor Measurement* section.

(4) PT1000 RTD approximate resistance: $800\ \Omega \equiv -52^\circ\text{C}$, $931\ \Omega \equiv -18^\circ\text{C}$, $1.10\text{ k}\Omega \equiv 26^\circ\text{C}$, $1.33\text{ k}\Omega \equiv 86^\circ\text{C}$ and $1.48\text{ k}\Omega \equiv 125^\circ\text{C}$.

(5) Specified currents include 120µA which flows through the RTD sensor in PT1000 mode (TEMP_RTD_SEL = 0).

(6) Specified currents include 240µA which flows through the RTD sensor in PT500 mode (TEMP_RTD_SEL = 1).

6.6 Timing Requirements

 $T_A = 25^\circ\text{C}$, $V_{DD} = V_{IO} = 3.7\text{ V}$ and $f_{SCLK} = 1\text{ MHz}$ (unless otherwise noted).

		MIN	TYP	MAX	UNIT
f_{SCLK}	Serial clock frequency			26	MHz
t_1	High period, SCLK	16			ns
t_2	Low period, SCLK	16			ns
t_3	Set-up time, nCS to SCLK	10			ns
t_4	Set-up time, SDI to SCLK	12			ns
t_5	Hold time, SCLK to SDI	12			ns
t_6	SCLK transition to SDO valid time	16			ns
t_7	Hold time, SCLK transition to nCS rising edge	10			ns
t_8	nCS inactive	17			ns
t_9	Hold time, SCLK transition to nCS falling edge	10			ns
t_r / t_f	Signal rise and fall times ⁽¹⁾		1.8		ns

(1) The slew rate is measured from 10% to 90% and is represented by the average of the rising and falling slew rates.

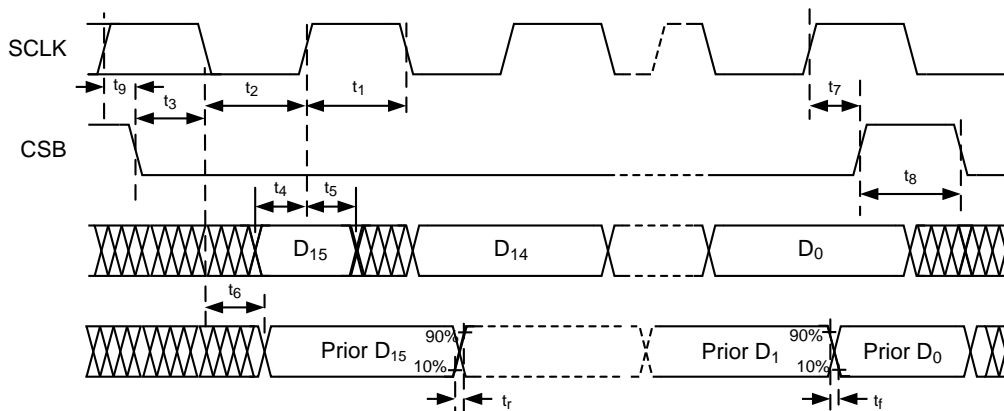

Figure 1. SPI Timing Diagram

6.7 Switching Characteristics

 $T_A = 25^\circ\text{C}$, $V_{DD} = V_{IO} = 3.7\text{ V}$, $f_{CLKIN} = 8\text{ MHz}$.

PARAMETER	TEST CONDITIONS	MIN	TYP	MAX	UNIT
START, STOP, ENABLE, CHSEL, RESET, CLOCKIN, TRIGGER, ERR					
PW _{START}	Pulse width for START signal	TX_FREQ_DIV = 2h, NUM_TX = 1	1		μs
		TX_FREQ_DIV = 2h, NUM_TX = 2	2		μs
		TX_FREQ_DIV = 2h, NUM_TX ≥ 3	3		μs
t_r / t_f _{START}	Rise/fall time for START signal	20% to 80%, 20-pF load	0.25		ns
t_r / t_f _{STOP}	Rise/fall time for STOP signal	20% to 80%, 20-pF load	0.25		ns
f_{CLKIN}	Maximum CLKIN input frequency		16		MHz
t_r / t_f _{CLKIN}	CLKIN input rise/fall time ⁽¹⁾	20% to 80%	10		ns
t_r / t_f _{TRIG}	TRIGGER input rise/fall time ⁽¹⁾	20% to 80%	10		ns
t_{EN_TRIG}	Enable to trigger wait time ⁽¹⁾		50		ns
t_{RES_TRIG}	Reset to trigger wait time ⁽¹⁾	TX_FREQ_DIV = 2h (see TX/RX Measurement Sequencing and Timing)	3.05		μs

(1) Specified by design.

6.8 Typical Characteristics

At $T_A = 25^\circ\text{C}$, unless otherwise noted.

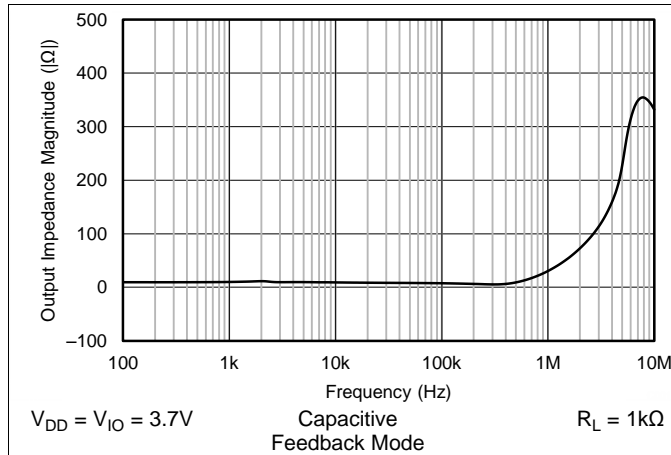

Figure 2. LNA Z_{OUT} vs Frequency

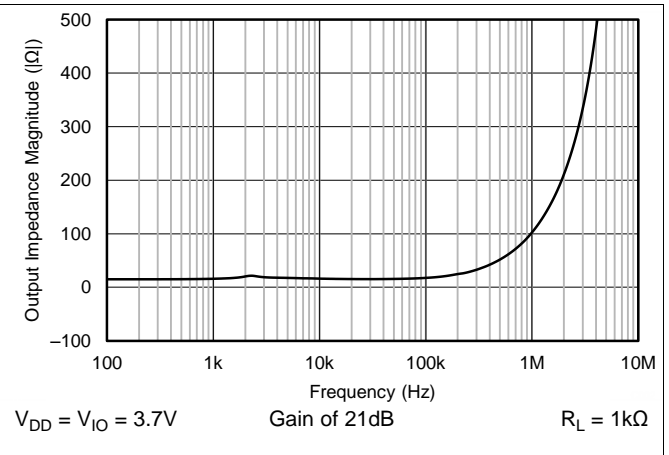

Figure 3. PGA Z_{OUT} vs Frequency

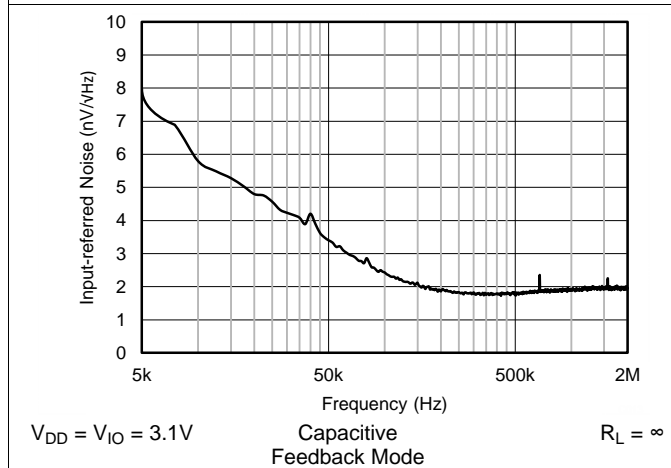

Figure 4. LNA Input-referred Noise vs Frequency

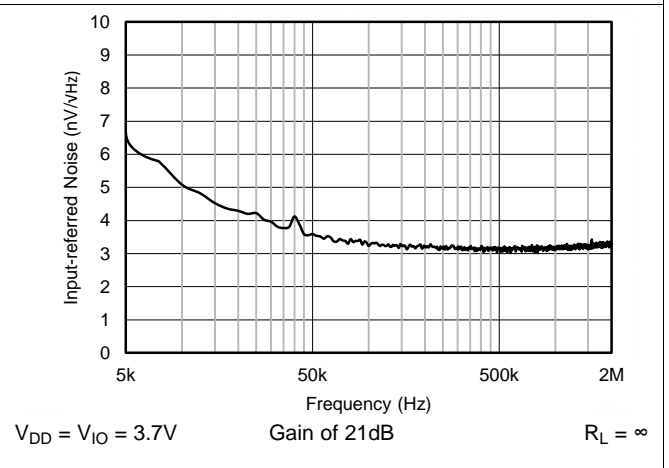

Figure 5. PGA Input-referred Noise vs Frequency

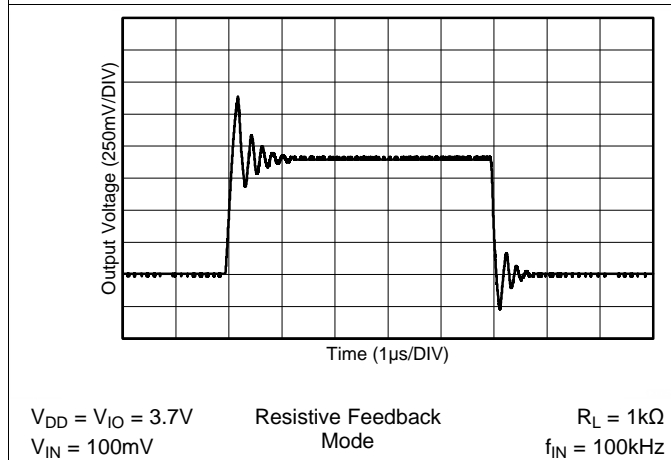

Figure 6. LNA Response

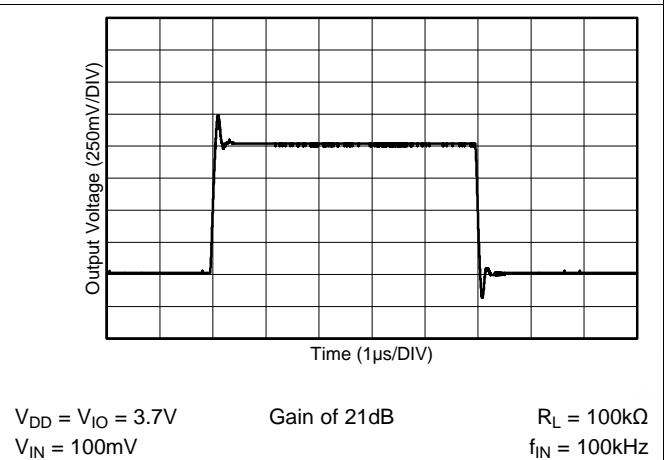
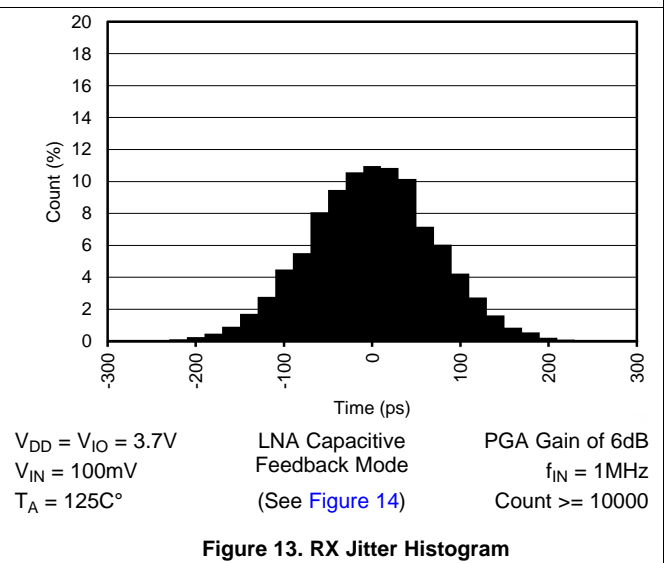
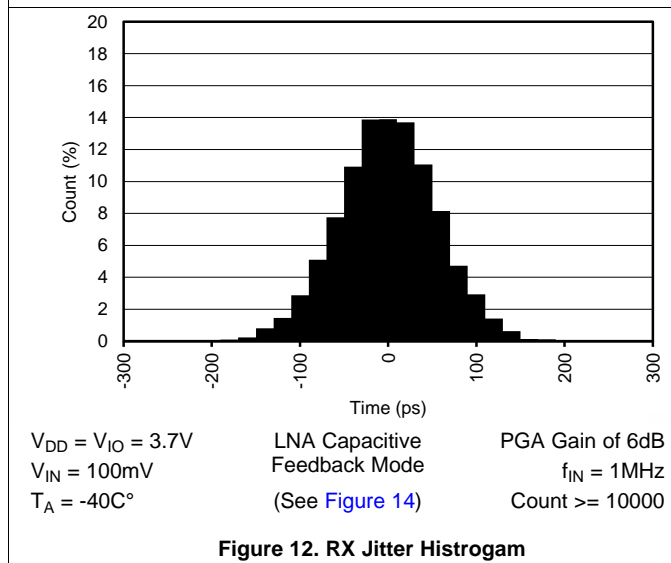
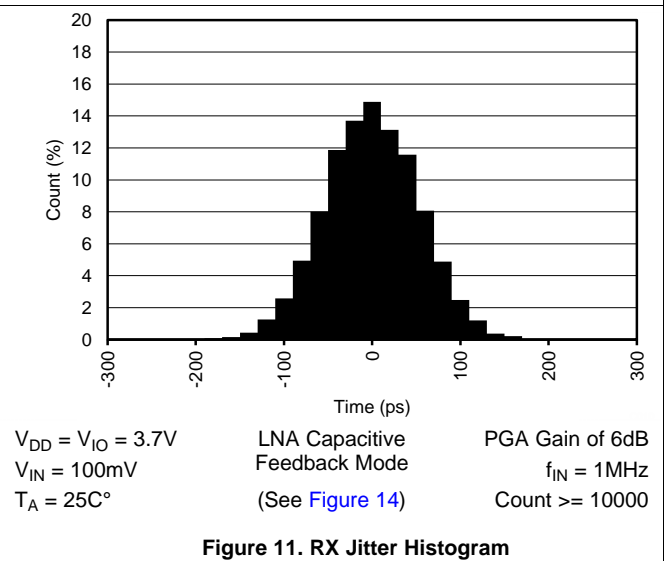
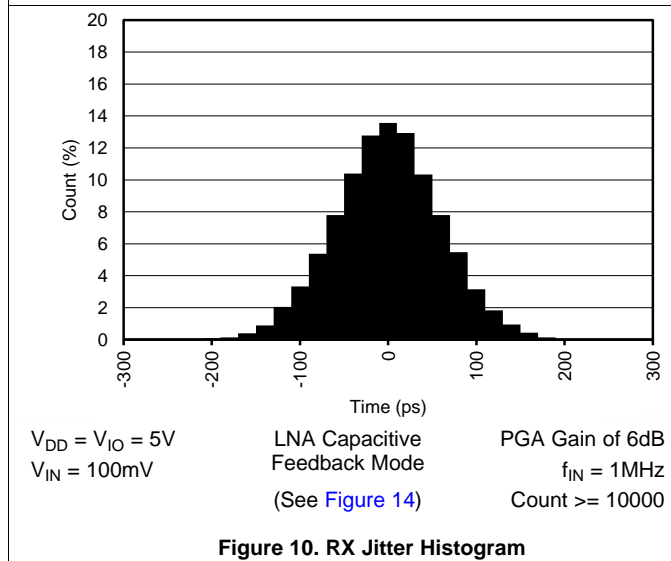
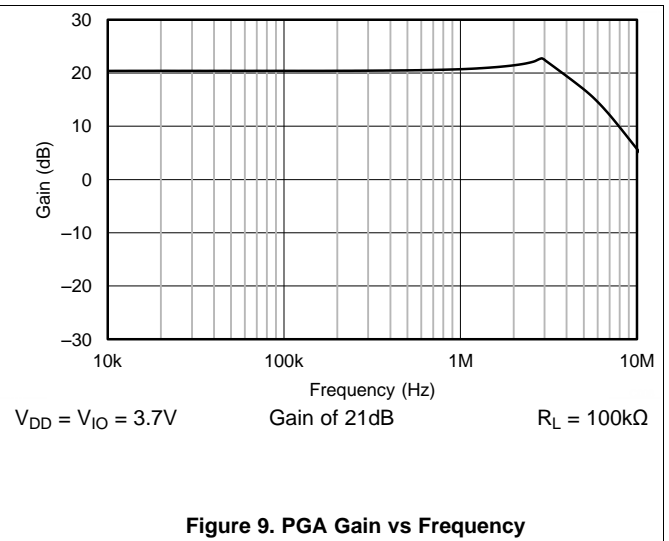
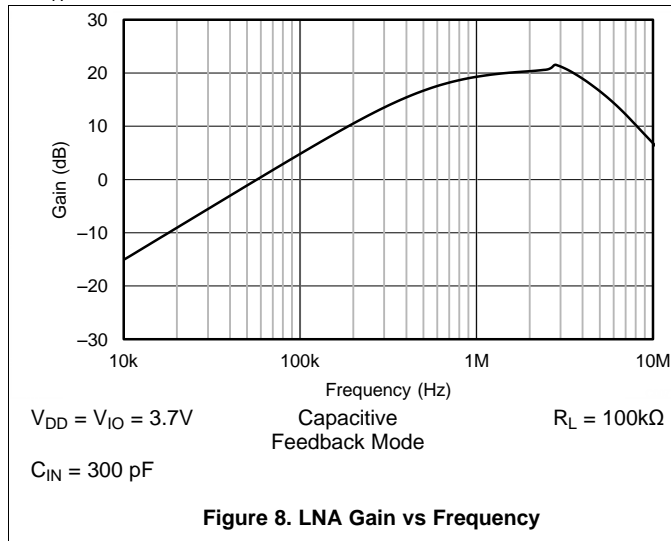

Figure 7. PGA Response

Typical Characteristics (continued)

At $T_A = 25^\circ\text{C}$, unless otherwise noted.



7 Parameter Measurement Information

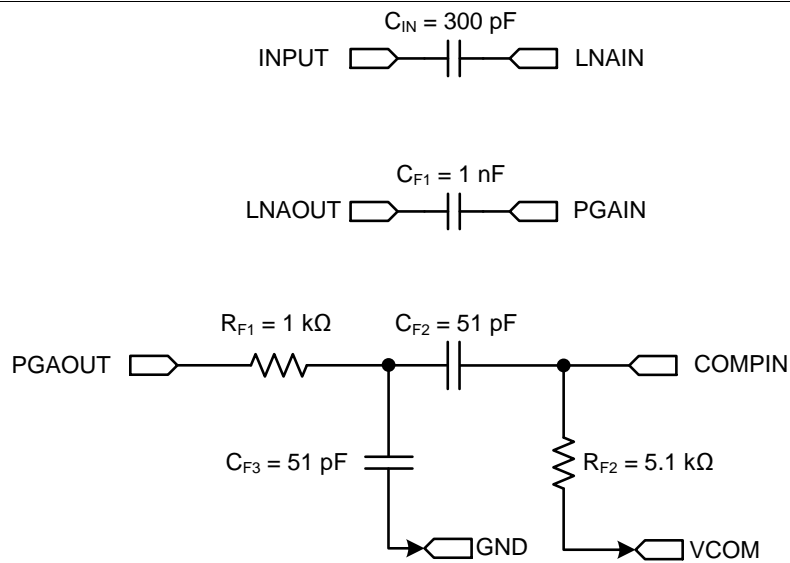

Figure 14. External Circuits for Jitter Measurement

8 Detailed Description

8.1 Overview

The main functional blocks of TDC1000 are the Transmit (TX) and the Receive (RX) Channels. The transmitter supports flexible settings for driving various ultrasonic transducers, and the receiver provides configurable blocks with a wide range of settings for signal conditioning in various applications. The receive signal chain consists of an LNA (Low Noise Amplifier), a PGA (Programmable Gain Amplifier), and two auto-zeroed comparators for echo qualification and STOP pulse generation.

The TDC1000 provides three modes of operation: *Mode 0*, *Mode 1* and *Mode 2*. Each mode is intended for one or more applications such as flow/concentration measurement, container level measurement, proximity detection, distance measurement, and a range of other applications where a precision measurement of Time-of-Flight (TOF) is required.

A measurement cycle is initiated with a trigger signal on the TRIGGER pin of the device. After a trigger signal is asserted, an output pulse is generated on the START pin. This signal is used as the time reference to begin a TOF measurement. The transmitter generates programmable TX pulses, synchronous to the rising edge of the START pulse, to drive an ultrasonic transducer and generate an ultrasonic wave that is shot through an acoustic medium. The receiver detects the ultrasound wave that traveled through the medium and generates STOP signals. Whether the ultrasound wave is received directly or from a reflection will depend on the system configuration. The STOP signals are used by an external Time-to-Digital Converter (TDC), which functions as a very accurate stopwatch. The system must include a TDC to measure the TOF based on the interval between the START and STOP pulses. In some applications with medium-range accuracy requirements (ns range), a microcontroller can be used to measure the TOF duration. In applications with high-range accuracy requirements (ps range), TI recommends using the TDC7200 time-to-digital converter to measure the TOF duration.

In each application, the TDC1000 has to be configured by a serial interface (SPI) for one of the three modes of operation available. In addition, the device must be programmed to various application-specific parameters that are explained in the following sections.

8.2 Functional Block Diagram

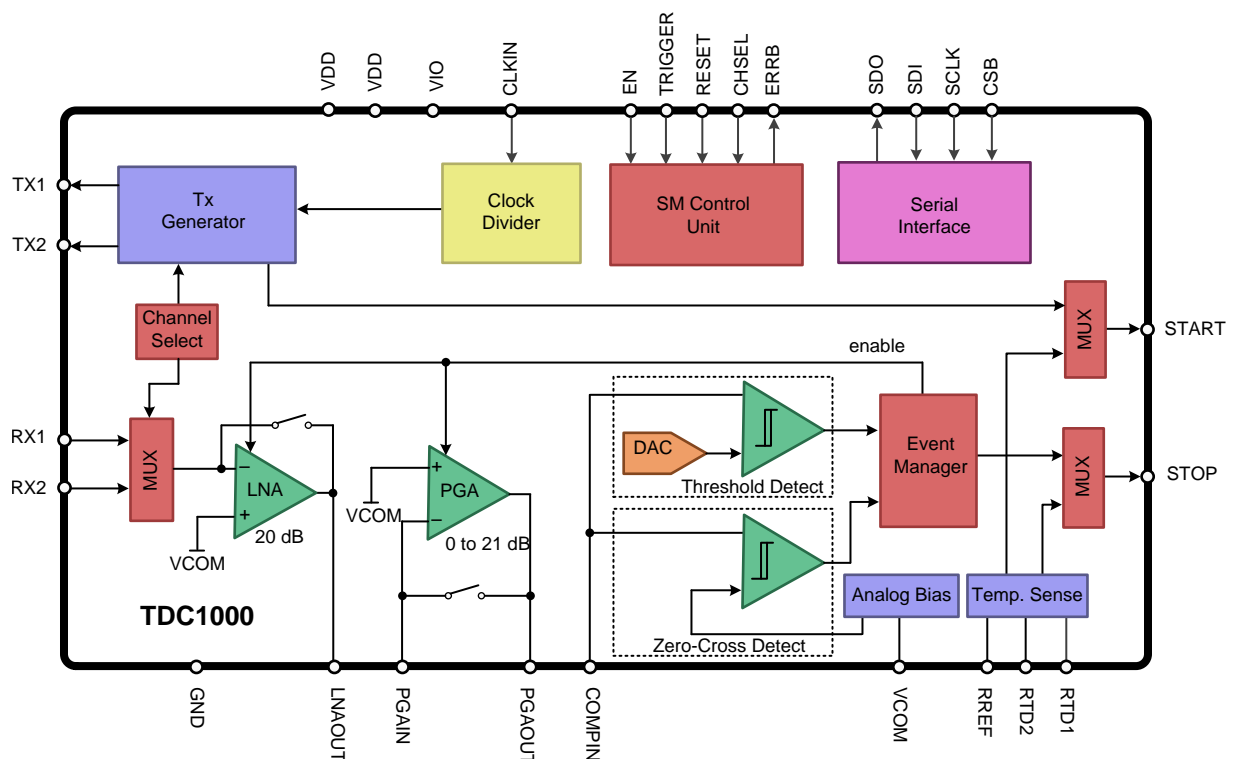

8.3 Feature Description

8.3.1 Transmitter Signal Path

The Transmitter (TX) path consists of a Clock Divider block and a TX Generator block. The clock divider allows the TDC1000 to divide the clock source that is connected to the CLKIN pin down to the resonant frequency (f_R) of the transducer used. The clock divider allows division factors in powers of 2. The division factor of the clock divider can be programmed with the `TX_FREQ_DIV` field in the `CONFIG_0` register.

The TX Generator block can drive a transducer with a programmable number of TX pulses. The frequency of these pulses is defined as $f_{CLKIN}/(2^{TX_FREQ_DIV+1})$, and should match the f_R of the transducer. The number of pulses is configured by programming the `NUM_TX` field in the `CONFIG_0` register.

For example, for $f_{CLKIN} = 8$ MHz and `TX_FREQ_DIV = 2h` (divide by 8), the divided clock frequency is 1 MHz.

In addition to the programmable number of pulses, the TX Generator also provides options to introduce a 180° pulse shift at pulse position n or damping the last TX pulse. In some situations, damping can reduce the ringing of the transducer for very short TOF measurements. These features are further described in the [TRANSMIT Operation](#) section of the datasheet.

8.3.2 Receiver Signal Path

The RX signal path consists of a channel selection multiplexer followed by an LNA. The output of the LNA can then be sent to the PGA for additional amplification if needed. Finally, the signal is fed into a set of comparators which generate pulses on the STOP pin based on the programmed threshold levels. The block diagram for the receiver path can be seen in [Figure 15](#).

If the 20-dB to 41-dB of gain provided by the TDC1000 is insufficient, additional gain can be added prior to the COMPIN pin. Likewise, with a strong received signal, if the gain from the LNA or PGA is not needed, they can be bypassed and the transducer signal could be directly connected to the COMPIN pin.

A band-pass filter centered on the transducer's response can be used between each stage of the receiver path to reduce the noise; note that the inputs of the LNA, PGA and comparators should be biased to the VCOM pin's potential. The comparators connected to the COMPIN pin are used for echo qualification and generation of STOP pulses that correspond to the zero-crossings of the echo signal. The STOP pulses are used with a START pulse to calculate the TOF of the echo in the medium.

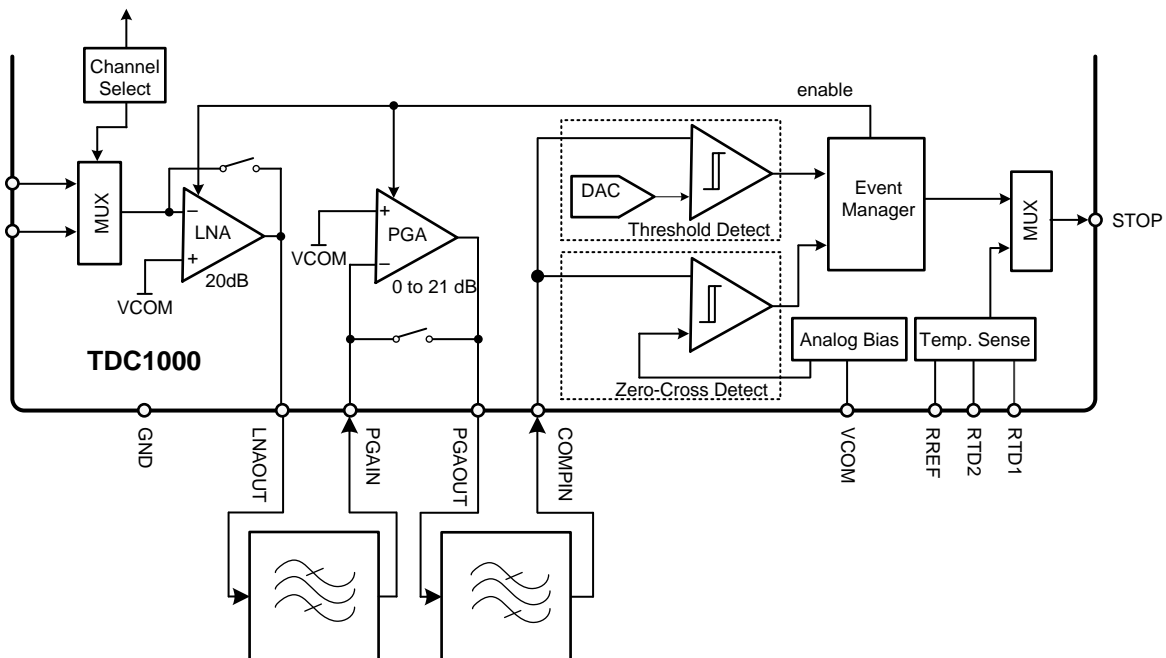

Figure 15. TDC1000 Receiver Path

Feature Description (continued)

8.3.3 Low Noise Amplifier (LNA)

The LNA in the TDC1000's front-end limits the input-referred noise and ensures timing accuracy for the generated STOP pulses. The LNA is an inverting amplifier designed for a closed-loop gain of 20 dB with the aid of an external input capacitor or resistor, and it can be programmed for two feedback configurations. The band-pass configuration, referred to as capacitive feedback mode, must be combined with an input capacitor. The low-pass configuration, referred to as resistive feedback mode, must be combined with an input resistor. The recommended values for the input components are 300 pF and 900 Ω respectively.

The LNA can be configured in capacitive feedback mode for transducers with resonant frequencies in the order of a couple of MHz. This is done by clearing the *LNA_FB* bit in the *TOF_1* register to 0. As shown in Figure 16, the external capacitor, C_{IN} , should be placed between the transducer and the corresponding input pin. This provides an in-band gain of C_{IN}/C_F , where C_F is the on-chip 30-pF feedback capacitor. Provided that $C_{IN} = 300$ pF, the in-band gain of the LNA circuit is:

$$\text{Gain}_{\text{in-band}} = \frac{C_{IN}}{C_F} = \frac{300 \text{ pF}}{30 \text{ pF}} = 10 \quad (1)$$

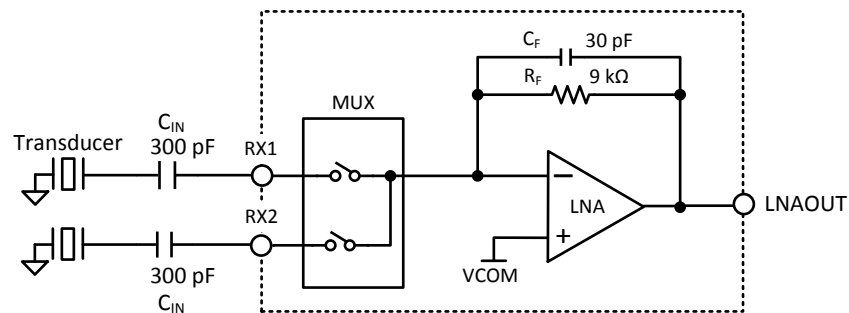

Figure 16. LNA Capacitive Feedback Configuration

The capacitive feedback configuration of the LNA has a band-pass frequency response. The high-pass corner frequency is set by the internal feedback components R_F (9 kΩ) and C_F (30 pF), and is approximately 590 kHz. The in-band gain is set by the capacitor ratio and the LNA's 50-MHz gain-bandwidth product sets the low-pass corner of the frequency response. For example, an in-band gain of 10 results in a bandpass response between 590 kHz and 5 MHz.

The LNA can be configured in resistive feedback mode for transducers with resonant frequencies in the order of a couple of hundreds of kHz. This is done by setting the *LNA_FB* bit in the *TOF_1* register to 1. In this configuration, the internal feedback capacitor C_F is disconnected (see Figure 17), and the DC gain of the LNA circuit is determined by the ratio between the internal feedback resistor R_F (9 kΩ) and an external resistor R_{IN} . For $R_{IN} = 900$ Ω, the gain of the circuit is 10.

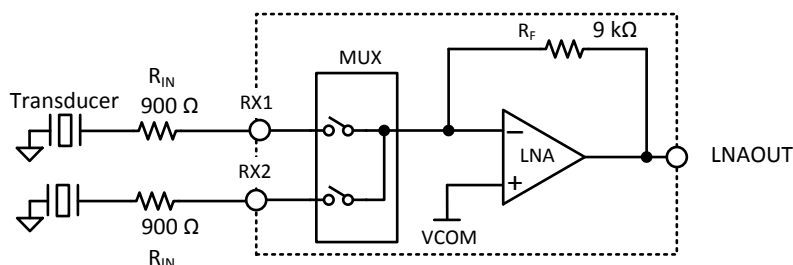

Figure 17. LNA Resistive Feedback Configuration

The LNA can be bypassed and disabled by writing a 1 to the *LNA_CTRL* bit in the *TOF_1* register.

Feature Description (continued)

8.3.4 Programmable Gain Amplifier (PGA)

The PGA, shown in Figure 18, is an inverting amplifier with an input resistance of $R_{IN} = 500 \Omega$ and a programmable feedback resistor R_{FB} that can be programmed to set a 0-dB to 21-dB gain in 3-dB steps. This can be done by programming the *PGA_GAIN* field in the *TOF_1* register. The bandwidth of the PGA is scaled based on its programmed gain. The typical bandwidth of the PGA with a 100-k Ω load to VCM and a 10-pF capacitor to ground are listed in Table 1.

Table 1. Typical PGA Bandwidth

PGA_GAIN (Hex)	Gain (dB)	Bandwidth (MHz)
0h	0	19.0
1h	3	16.8
2h	6	14.4
3h	9	12.3
4h	12	10.0
5h	15	8.2
6h	18	6.6
7h	21	5.0

The PGA can be bypassed and disabled by writing a 1 to the *PGA_CTRL* bit in the *TOF_1* register. The output of the PGA should not be loaded directly with capacitances greater than 10 pF.

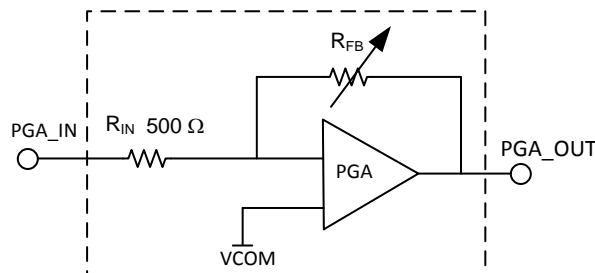

Figure 18. TDC1000 Programmable Gain Amplifier

8.3.5 Receiver Filters

It is recommended to place two filters in the RX path to minimize the receive path noise and obtain maximum timing accuracy. As shown in Figure 19, one filter is placed between the LNAOUT and the PGAIN pins, and another filter is placed between the PGAOUT and the COMPIN pins.

With an in-band gain of 10, the LNA has a bandwidth of 5 MHz. For most applications, a low-pass filter between the LNAOUT and PGAIN pins is sufficient.

As shown in Figure 19, the second filter stage can use a cascade of a low-pass filter (R_{F1} and C_{F3}) followed by a high-pass filter (C_{F2} and R_{F2}) referenced to VCOM. Design of the filter is straightforward. The R_{F1} and C_{F2} can be chosen first. A reasonable set of values for R_{F1} and C_{F2} could be: $R_{F1} = 1 \text{ k}\Omega \pm 10\%$ and $C_{F2} = 50 \text{ pF} \pm 10\%$. Given the center frequency of interest to be f_C and the filter bandwidth to be f_B , the value of C_{F3} can be calculated as:

$$C_{F3} = \frac{1}{2\pi R_{F1}(f_C + f_B)} \quad (2)$$

R_{F2} and C_{F2} determine the high-pass corner of the filter. R_{F2} should be referenced to VCOM to maintain the DC bias level at the comparator input during the echo receive time. For values of R_{F2} larger than R_{F1} , there will be limited loading effect from the high-pass filter to the low-pass filter resulting in more accurate corner frequencies. The chosen values shown in the figure below result in a high-pass corner frequency of about 600 kHz and a low-pass corner frequency of about 3 MHz.

More complex filters can be used; external gain is acceptable if the signal amplitude is too low. If the pass-band of the filter is wider than an octave, it is recommended to use a filter design which has linear group delay.

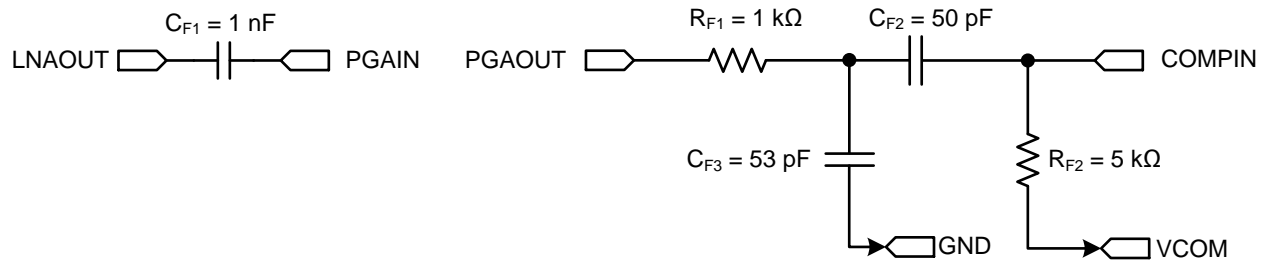

Figure 19. Filter for a 1-MHz Operation

8.3.6 Comparators for STOP Pulse Generation

The STOP pulse generation block of the TDC1000 contains two auto-zeroed comparators (a zero-cross detect and a threshold-detect comparator), a threshold setting DAC, and an event manager.

Comparator auto-zero periods occur at the beginning of every TOF receive cycle. During these periods, the comparator's input offset is stored in an internal 2.5-pF capacitor, and it is subtracted from the input signal during the echo processing phase. The duration of auto-zero period is configured with the *AUTOZERO_PERIOD* field located in the *CLOCK_RATE* register.

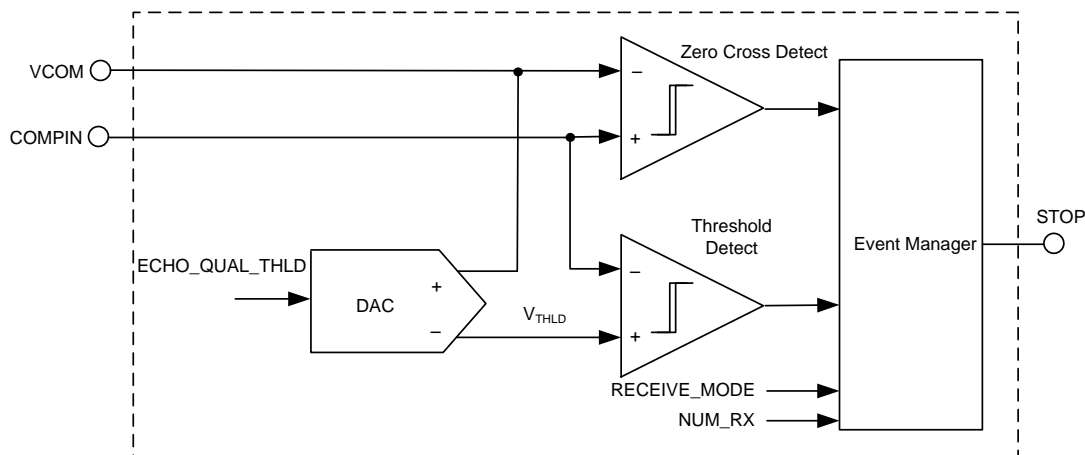

Figure 20. STOP Pulse Generation Circuit

8.3.6.1 Threshold Detector and DAC

The threshold detect comparator in [Figure 20](#) compares the echo amplitude with a programmable threshold level (V_{THLD}) controlled by a DAC. The DAC voltage is set by the *ECHO_QUAL_THLD* field in register *CONFIG_3* and provides 8 programmable threshold levels, V_{THLD} . The typical levels are summarized in [Table 2](#):

Table 2. Echo Qualification Threshold Levels

ECHO_QUAL_THLD	0h	1h	2h	3h	4h	5h	6h	7h
Typical V_{THLD} (mV)	-35	-50	-75	-125	-220	-410	-775	-1500

8.3.6.2 Zero-cross Detect Comparator

The zero-cross detect comparator compares the amplified echo signal at COMPIN with its reference voltage, which is V_{COM} . As shown in [Figure 21](#), the comparator produces a low-to-high transition when the amplitude of the echo signal rises above V_{COM} . The comparator produces a high-to-low transition when the echo amplitude falls below $V_{COM} - V_{HYST}$. The built-in negative-sided hysteresis of 10 mV in reference to V_{COM} ensures accurate zero-cross time instances associated with the rising edges of the echo signal and immunity of the comparator output to noise.

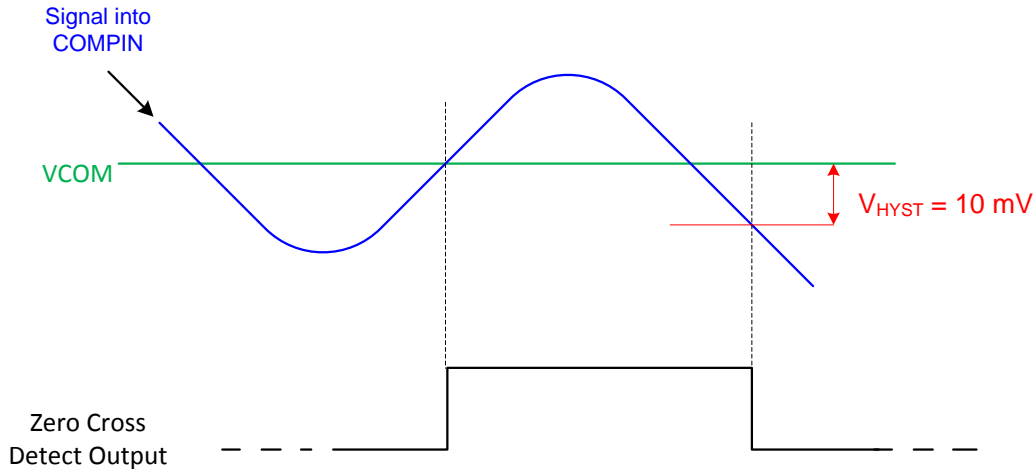

Figure 21. Zero-Cross Detector Output Signal

The output of the zero-cross detect comparator is passed to the event manager, where depending on the decision of the threshold-detect comparator.

8.3.6.3 Event Manager

The event manager is a digital state machine in the STOP pulse generation circuit of the TDC1000. The event manager controls the maximum number of STOP pulses to generate on the STOP pin and the receive mode for the STOP pulse generation. The number of STOP pulses is configured in the *NUM_RX* field in the *CONFIG_1* register. The receive mode is selected in the *RECEIVE_MODE* bit of the *CONFIG_4* register. See sections *Single Echo Receive Mode* and *Multiple Echo Receive Mode* for details about the receiver modes of the TDC1000.

An example for *NUM_RX* = 2h and *RECEIVE_MODE* = 0 is shown in Figure 22. When the echo signal amplitude exceeds values smaller than V_{THLD} , the threshold detect comparator indicates to the event manager to qualify the next zero-cross event as valid. When the qualified zero-cross is detected by the zero-cross detect comparator, the event manager passes the pulse to the STOP pin until the number of receive events programmed in *NUM_RX* is reached.

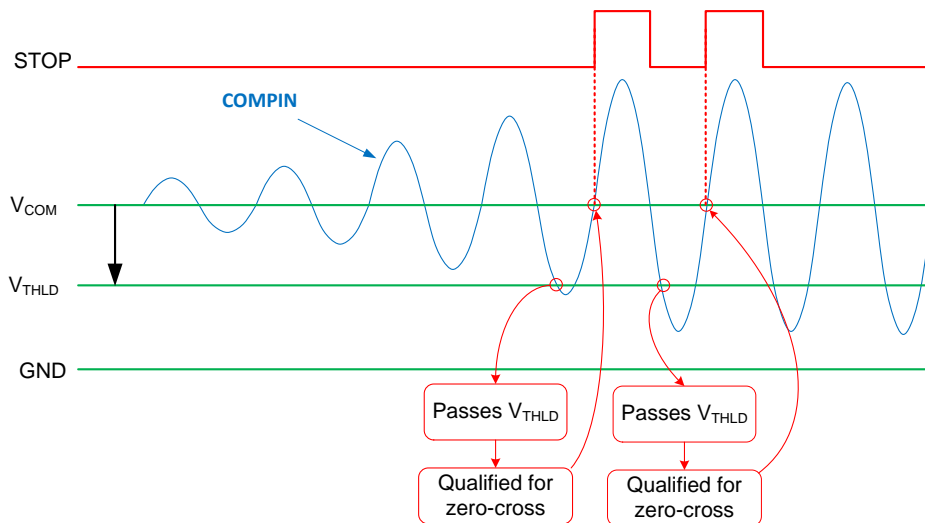

Figure 22. Signal Qualification, Zero-cross Detection and STOP Pulse Generation

8.3.7 Common-mode Buffer (VCOM)

The output of the internal common-mode buffer is present at the VCOM pin. This pin should be bypassed to ground with a low-leakage 10-nF capacitor and it should not be loaded with more than 20 μ A. The common-mode buffer can be disabled with the *VCOM_SEL* bit in the *CONFIG_2* register. If disabled, an external reference voltage must be applied to the VCOM pin.

During a time-of-flight measurement, the common-mode reference will take approximately 16 μ s to settle if starting from zero initial conditions. Using a larger capacitor will increase the settling time of the internal common-mode reference. The implications of a larger VCOM capacitor are further explored in the *Common-mode Reference Settling Time* section.

8.3.8 Temperature Sensor

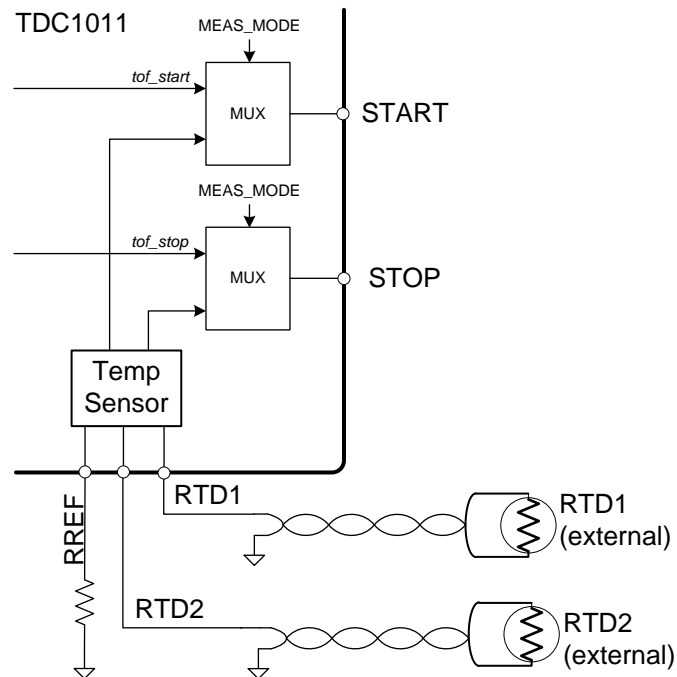

Figure 23. Temperature Sensor Measurement

Accurate measurements of flow, level, and concentration require compensation for the temperature dependency of the speed of sound in the medium. The TDC1000 provides two temperature sensor connections, allowing to measure up to two locations with RTDs, as shown in [Figure 23](#).

The temperature sensor block supports PT1000 or PT500 sensors. The type of RTD used must be selected in the *TEMP_RTD_SEL* bit of the *CONFIG_3* register. The system requires a temperature-stable external reference resistor (R_{REF}). If the RTD type is PT500, then R_{REF} should be 500 Ω . If the RTD type is PT1000, then R_{REF} should be 1 k Ω . The reference resistor needs to have either a low temperature coefficient or be calibrated for temperature shift.

The logic timing in a temperature measurement is controlled by the *TEMP_CLK_DIV* bit in the *CONFIG_3* register. As shown in [Figure 24](#), the external clock can be divided by 8 or by the value resulting from the *TX_FREQ_DIV* field configuration in the *CONFIG_0* register. It is recommended to operate the temperature measurement block at frequencies of 1 MHz or less.

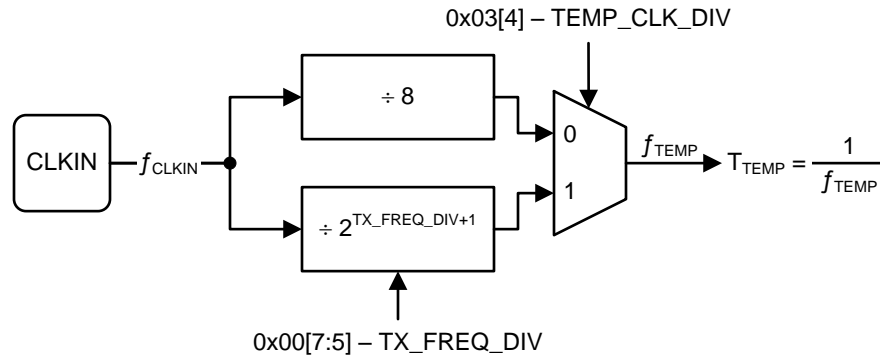

Figure 24. Timing Source for the Temperature Measurement

8.3.8.1 Temperature Measurement with Multiple RTDs

The temperature measurement mode is selected by setting the MEAS_MODE bit in the CONFIG_2 register to 1. A temperature measurement is started by sending a trigger pulse. After the temperature measurement is complete, the TDC1000 returns to SLEEP mode. To return to TOF measurement mode, reset the MEAS_MODE bit to 0.

The temperature sensor measurement can be performed without the need of an external ADC. The temperature sensor block operates by converting the resistance of a reference, R_REF, and up to two RTDs into a series of START and STOP pulses. The interval between the pulses is proportional to the measured resistance, and therefore, the temperature. As shown in Figure 25, the TDC1000 performs three measurements per trigger event and generates the corresponding pulses on the START and STOP pins.

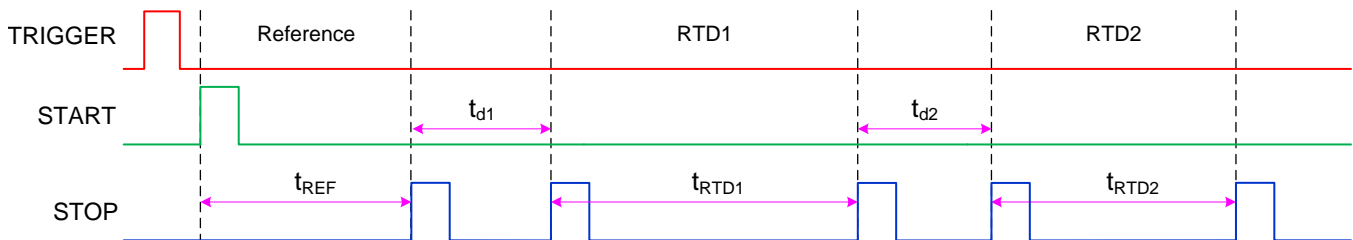

Figure 25. Temperature Measurement Output Timing

The resistance of RTD1 and RTD2 can be calculated from the time intervals in Figure 25 as follows:

$$R_{RTDx} = R_{REF} \times \frac{t_{REF}}{t_{RTDx}} \quad (3)$$

With a 1-kΩ reference resistor, the t_REF interval is approximately 200 μs. The following intervals, t_RT1 and t_RT2, will depend on the resistance of the RTDs. The time delay between measurements, t_d1 and t_d2, can be approximated as follows:

$$t_{d1} = (51 \times T_{TEMP}) + (t_{RT1} \times 0.55) \quad (4)$$

$$t_{d2} = (51 \times T_{TEMP}) + (t_{RT2} \times 0.55) \quad (5)$$

For example, two PT1000 sensors at 0°C will have an approximate resistance of 1 kΩ; the same as the reference resistor in this example. Given an external 8-MHz clock and the default temperature clock divide-by-8 from the TEMP_CLK_DIV bit, the overall measurement time between the START pulse and the last STOP pulse is approximately 922 μs.

8.3.8.2 Temperature Measurement with a Single RTD

The temperature sensing block can be configured to measure a single RTD by setting the *TEMP_MODE* bit in register *CONFIG_3* to 1. When the temperature measurement runs in PT1000 mode (*TEMP_RTD_SEL* = 0), the first interval corresponds to R_{REF} , the second interval is a redundant measurement on R_{REF} and should be neglected, and the third interval corresponds to RTD1. This operation is represented in Figure 26.

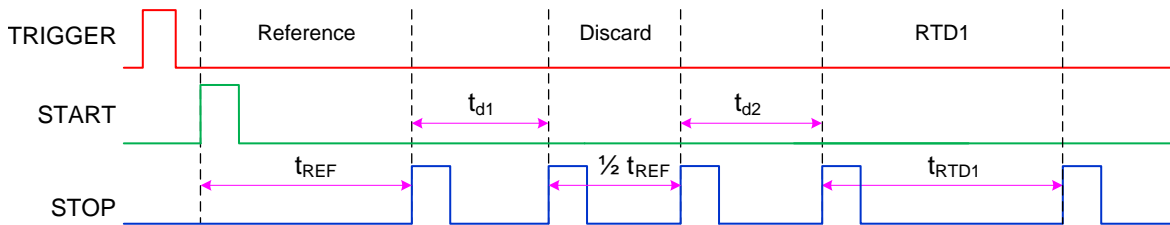

Figure 26. Temperature Measurement with a Single PT1000

The resistance of RTD1 can be calculated using Equation 3. The time delay between measurements can be approximated using Equation 4 and Equation 5, with the exception that in this case, t_{d1} is a function of $\frac{1}{2} t_{REF}$ and t_{d2} is a function of t_{RTD1} .

If the temperature measurement runs in PT500 mode (*TEMP_RTD_SEL* = 1), the first interval is a redundant measurement on R_{REF} and should be neglected, the second interval corresponds to R_{REF} , and the third interval corresponds to RTD1. This operation is represented in Figure 27.

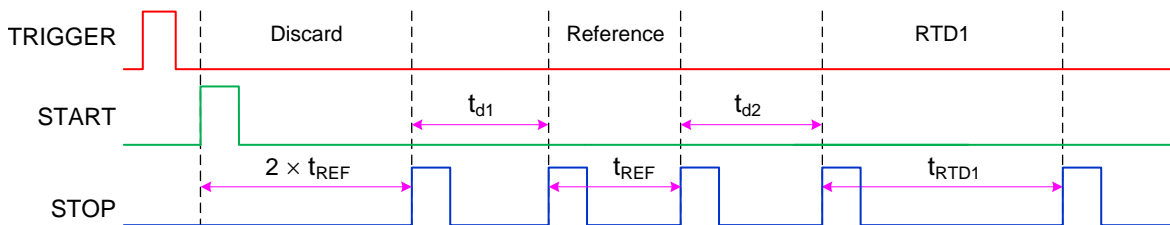

Figure 27. Temperature Measurement with a Single PT500

The resistance of RTD1 can be calculated using Equation 3. The time delay between measurements can be approximated using Equation 4 and Equation 5, with the exception that in this case, t_{d1} is a function of t_{REF} and t_{d2} is a function of t_{RTD1} .

8.4 Device Functional Modes

8.4.1 Time-of-Flight Measurement Mode

The TOF measurement mode is selected by setting the *MEAS_MODE* bit in the *CONFIG_2* register to 0. The type of TOF measurement mode can be selected with the *TOF_MEAS_MODE* field in the *CONFIG_2* register. Table 3 lists the available TOF measurement modes with their corresponding channel assignments.

Table 3. TOF Measurement Modes

TOF_MEAS_MODE		CH_SEL		EXT_CHSEL	Active TX Channel	Active RX Channel
Mode 0	00	Channel 1	0	0	TX1	RX2
		Channel 2	1	0	TX2	RX1
Mode 1	01	Channel 1	0	0	TX1	RX1
		Channel 2	1	0	TX2	RX2
Mode 2	10	Channel 1	0	0	Based on state machine and CH_SWP bit	
		Channel 2	1	0	Based on state machine and CH_SWP bit	
Reserved	11	Reserved				

8.4.1.1 Mode 0

Mode 0 is intended for [Level and Fluid Identification Measurements](#) applications. The TDC1000 associates each transducer to complementary TX and RX channels. The transmit/receive pair "TX1/RX2" will act as both transmitter and receiver for a measurement if $CH_SEL = 0$ in the [CONFIG_2](#) register. The transmit/receive pair "TX2/RX1" will act as both transmitter and receiver for the measurement if $CH_SEL = 1$.

The TDC1000 performs a single TOF measurement after receiving a trigger signal and returns to the SLEEP mode when the measurement is complete.

8.4.1.2 Mode 1

In Mode 1 the TDC1000 associates each transducer to a single TX and RX channels. The transmit/receive pair "TX1/RX1" will act as both transmitter and receiver for a measurement if $CH_SEL = 0$. The transmit/receive pair "TX2/RX2" will act as both transmitter and receiver for the measurement if $CH_SEL = 1$.

The TDC1000 performs a single TOF measurement (one direction) and returns to the SLEEP mode when the measurement is complete.

8.4.1.3 Mode 2

Mode 2 is intended for transit time water flow metering applications (see [Water Flow Metering](#)). In this mode, the channel definitions are the same as for Mode 1: Channel 1 = "TX1/RX1" and Channel 2 = "TX2/RX2". The TDC1000 will perform one TOF measurement and go into READY state waiting for the next trigger signal.

Mode 2 supports averaging cycles and automatic channel swap. The averaging mode is active if $NUM_AVG > 0$ and allows for the stopwatch or MCU to perform the average of multiple TOF measurement cycles. In this mode, the device performs a TOF measurement on one channel (direction) for every trigger pulse until the averaging count is reached, and if $CH_SWP = 1$, it will automatically swap channels and perform a TOF measurement on the other channel (direction) for every trigger pulse until the averaging count is reached.

The number of averages is controlled with the NUM_AVG field found in the [CONFIG_1](#) register. Channel swapping is controlled with the CH_SWP bit in the [CONFIG_2](#) register. The EXT_CHSEL bit in the [CONFIG_2](#) register must be 0 for automatic channel swap to work. If EXT_CHSEL is 1, the active channel selection is controlled manually with the $CHSEL$ pin.

NOTE

If an echo measurement times out in averaging mode (indicated by the error flags or $ERRB$ pin), the state machine should be reset and the error flags should be cleared. The state machine can be cleared by writing a 1 to bit [1] of the $ERROR_FLAGS$ register and the error flags can be cleared by writing a 1 to bit [0] of the $ERROR_FLAGS$ register. After completing these steps, the averaged measurement should be restarted.

8.4.2 State Machine

A state machine in the TDC1000 manages the operation of the various measurement modes (see [Figure 28](#)). At power-on, the state machine is reset and most blocks are disabled. After the power-on sequence is complete, the device goes into SLEEP mode if the EN pin is low or into READY mode if the EN pin is high. In the SLEEP or READY state, the TDC1000 is able to receive SPI commands to set registers and configure the device for a measurement mode.

NOTE

Although the SPI block is always active, it is not recommended to perform configuration changes while the device is active. Configuration changes should be performed while the device is in the SLEEP state or in the READY state.

If the EN pin is high and a trigger signal is received, the state machine will begin the execution of the configured measurement. If the device is configured in Mode 0 or Mode 1, the state machine will return to the SLEEP state after the measurement is completed. If the device is configured in Mode 2, the state machine returns to the READY state and waits for the next trigger to continue with the next measurement.

The device can be forced to exit a measurement by applying a logic high on the RESET pin high or a logic low on the EN pin.

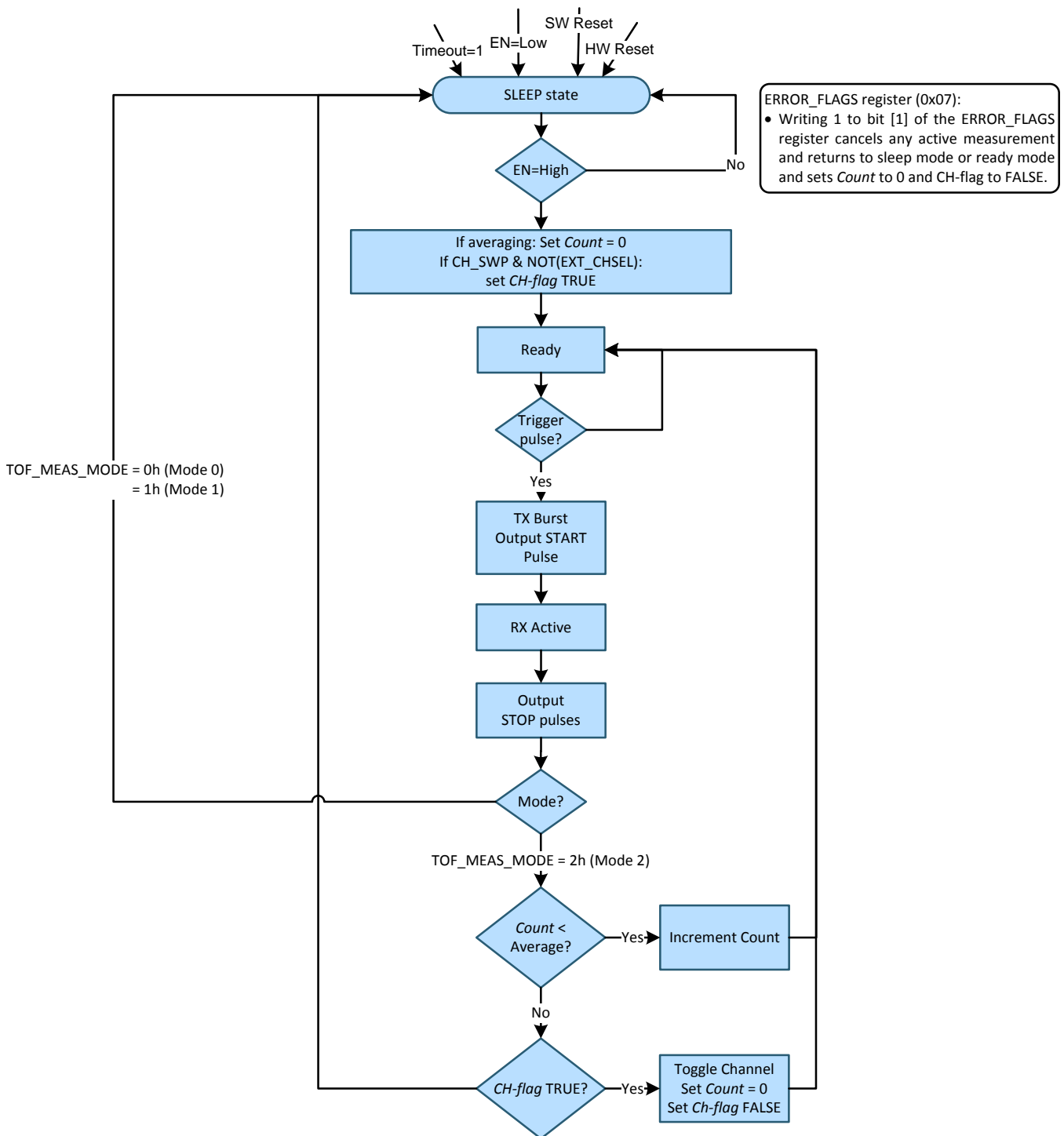

Figure 28. Simplified TDC1000 State Machine Diagram

8.4.3 TRANSMIT Operation

8.4.3.1 Transmission Pulse Count

The number of TX pulses generated by the TDC1000 to drive an ultrasonic transducer is programmable using the `NUM_TX` field located in the `CONFIG_0` register.

8.4.3.2 TX 180° Pulse Shift

As shown in [Figure 29](#), the transmitter block can add a 180° shift at a position in the TX signal. The position of the pulse shift is set by the `TX_PH_SHIFT_POS` field in the `CONFIG_4` register and allows generating a specific signal pattern.

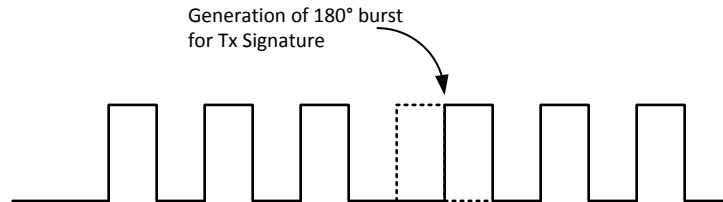

Figure 29. Transmitter Pulse Signature, 180° Burst

As shown in [Figure 30](#), enabling the TX 180° pulse shift has the effect of decreasing the number of transmitted pulses by 1.

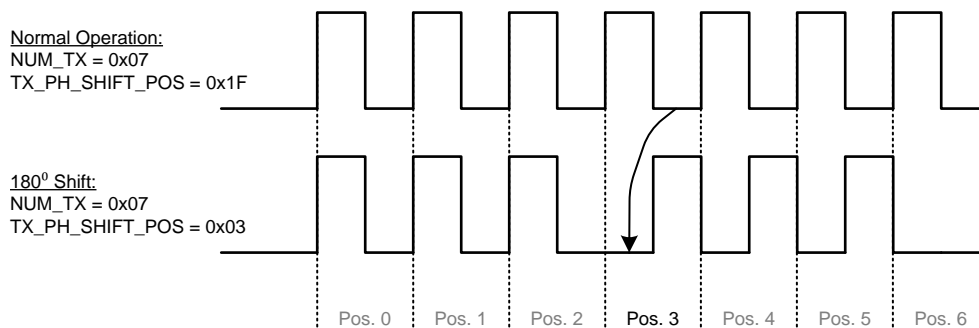

Figure 30. Transmitter Pulse Signature

In some cases, the 180° pulse shift may help improving the turn-off time of a transducer, and thus suppress the transmit ringing.

The 180° pulse shift is disabled by setting `TX_PH_SHIFT_POS` to position 31. Setting the 180° pulse shift to positions 0 or 1 is not recommended.

8.4.3.3 Transmitter Damping

The transmitter damping feature allows for improved control over the transducer signal generation. Damping extends the duration of the last TX pulse to help dissipate ringing and improve the transducer's turn-off time (see [Figure 31](#) and [Figure 32](#)). The accuracy of measurements can be improved by having a faster transducer turn-off time. Damping is controlled with the `DAMPING` bit in the `CONFIG_2` register.

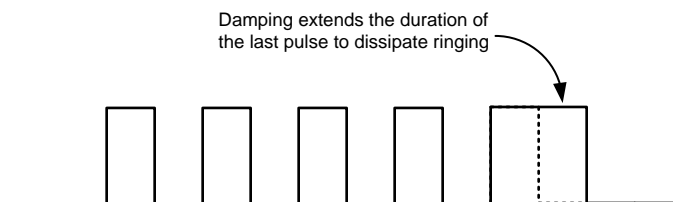

Figure 31. Transmitter Damping (5 Tx Pulses With a Damping Pulse)

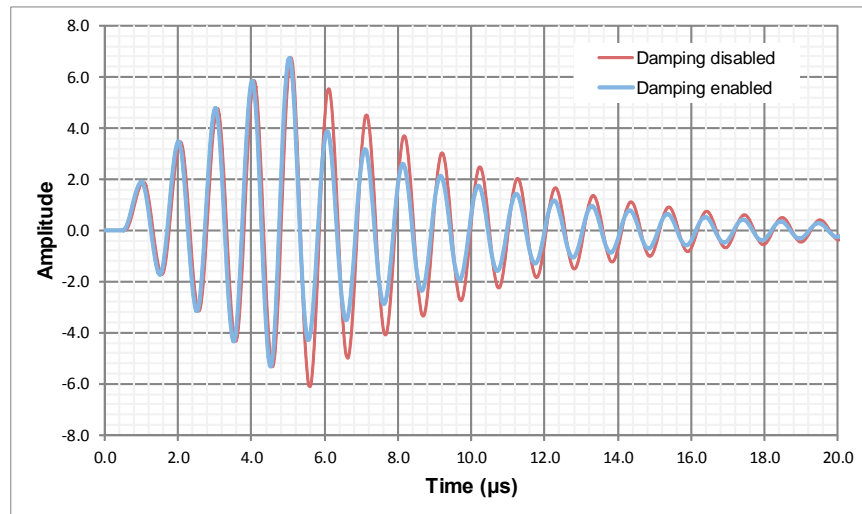

Figure 32. Transmitter Damped Echo

There are two invalid use combinations of the damping feature that may result in unexpected behavior. First, damping should not be combined with the 180° pulse shift described in the previous section. Second, damping should not be enabled if the number of TX pulses is set to 31.

8.4.4 RECEIVE Operation

8.4.4.1 Single Echo Receive Mode

Single Echo mode is suitable for concentration measurements and flow metering applications. The device can be configured for Single Echo mode by setting the *RECEIVE_MODE* bit to 0 in the *CONFIG_4* register. In Single Echo mode, the device will generate STOP pulses for every zero-cross qualified by the threshold comparator, up to the number of expected STOP events configured in the *NUM_RX* field in the *CONFIG_1* register.

The threshold comparator qualifies the next zero-cross after an RX amplitude smaller than the programmed threshold voltage is detected. The zero-cross detector will provide output pulses corresponding to the rising edge of the received signal crossing the V_{COM} level, as shown in Figure 33. The threshold voltage can be set in the *ECHO_QUAL_THDL* field in the *CONFIG_3* register.

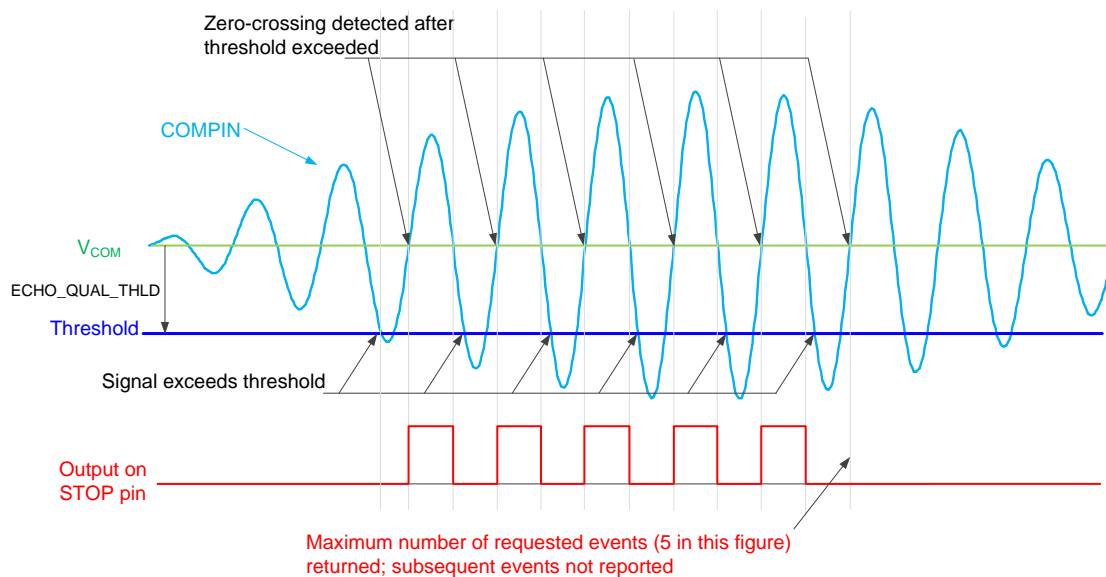

Figure 33. Single Echo Receive Mode (5 STOP Events)

If the number of expected pulses programmed in *NUM_RX* is not received or the time-of-flight operation times out, the TDC1000 will indicate an error condition in the *ERROR_FLAGS* register and will set the ERRB pin low.

8.4.4.2 Multiple Echo Receive Mode

The Multiple Echo mode is intended for use in level sensing applications and distance/displacement measurements in which multiple echoes (burst) are received. In this condition, each received echo group will be treated as a single pulse on the STOP pin. Up to 7 STOP pulses can be generated based on the value of the *NUM_RX* field in the *CONFIG_1* register. Multi echo mode can be enabled by setting the *RECEIVE_MODE* bit to 1 in the *CONFIG_4* register. A representation of multiple echo STOP pulse generation is shown in Figure 34.

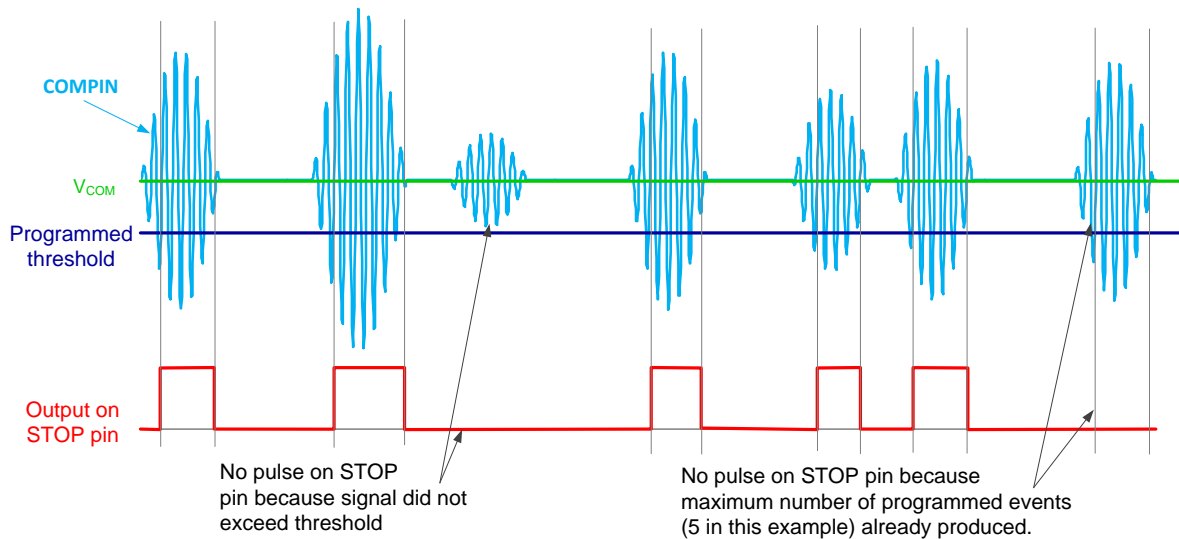

Figure 34. Multiple Echo Receive Mode (5 STOP Events)

The rising edge of a STOP pulse is generated by a zero-crossing event. As in the Single Echo Receive Mode, the threshold comparator qualifies the next zero-cross after an RX amplitude smaller than the programmed threshold voltage is detected. The STOP pulse will extend until a zero-cross after the RX amplitude is no longer smaller than the threshold voltage (see Figure 35).

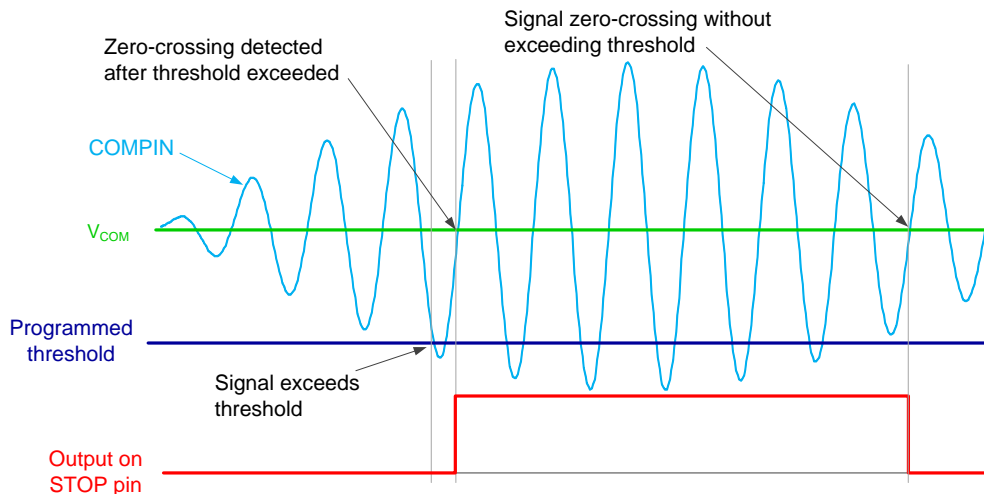

Figure 35. Multiple Echo Receive Mode (Zoom-in)

If the number of expected pulses programmed in *NUM_RX* is not received or the time-of-flight operation times out, the TDC1000 will indicate an error condition in the *ERROR_FLAGS* register and will set the ERRB pin low.

8.4.5 Timing

8.4.5.1 Timing Control and Frequency Scaling (CLKIN)

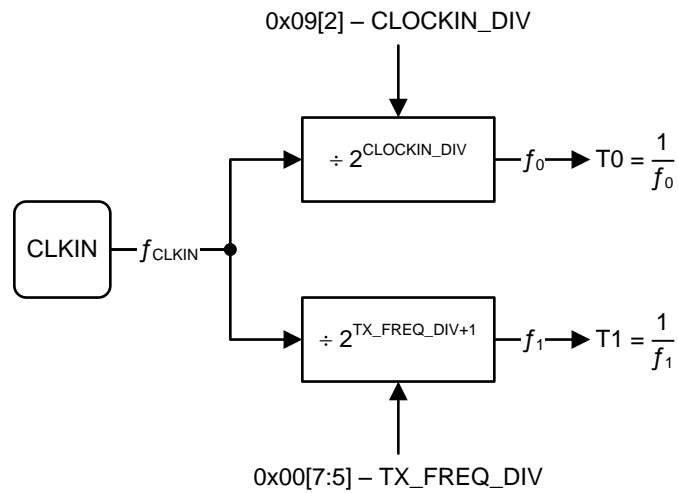

Figure 36. External Clock Division Tree

All transmit and receive function sequencing is synchronous to the external clock applied to the CLKIN pin. The external clock is divided to generate two internal clocks with corresponding time periods denoted as T0 and T1 in [Figure 36](#). The division factor used to generate T0 is controlled with the *CLOCKIN_DIV* bit in the [CLOCK_RATE](#) register. The division factor used to generate T1 is controlled with the *TX_FREQ_DIV* field located in the [CONFIG_0](#) register.

The SPI block is synchronous with the clock applied to the SCLK pin, and it is independent of the clock applied to CLKIN. See the [Serial Peripheral Interface \(SPI\)](#) section for a complete description of the SPI block.

8.4.5.2 TX/RX Measurement Sequencing and Timing

The TDC1000 automatically sequences the TX and RX functionality. After receiving a pulse edge on the TRIGGER pin, the TDC1000 resynchronizes to the CLKIN signal, and sends a TX burst. During the transmission burst, the RX path is set to the alternate channel to minimize coupled noise.

During resynchronization, the trigger and START edges are aligned to the negative edge of the external clock. The time between trigger and START is equal to 3 T0 periods plus 2 or 3 T1 periods, depending on the phase between the received trigger pulse and the external clock. For example, if $f_{CLKIN} = 8$ MHz and *TX_FREQ_DIV* = 0x2 (divide-by-8), the period T0 is 125 ns and the period T1 is 1 μ s, resulting in a time of 2.375 μ s or 3.375 μ s between the received trigger signal and the generated START pulse.

The trigger edge polarity is configured to rising edge by default, but it can be changed to falling edge by setting the *TRIG_EDGE_POLARITY* bit in the [CONFIG4](#) register to 1.

After a device reset, the system must wait a determined time before sending the next trigger signal. The typical reset to trigger wait time is $3 \times T1 + (50 \text{ ns})$.

8.4.6 Time-of-Flight (TOF) Control

The possible configurations of the TX/RX sequencing during a time-of-flight measurement can be divided into three cases: [Short TOF Measurement](#), [Standard TOF Measurement](#) and [Standard TOF Measurement with Power Blanking](#). Overall, the cases differ in the order of sequencing, power saving and echo listening windows. The behavior of each case is described in the sections to follow.

8.4.6.1 Short TOF Measurement

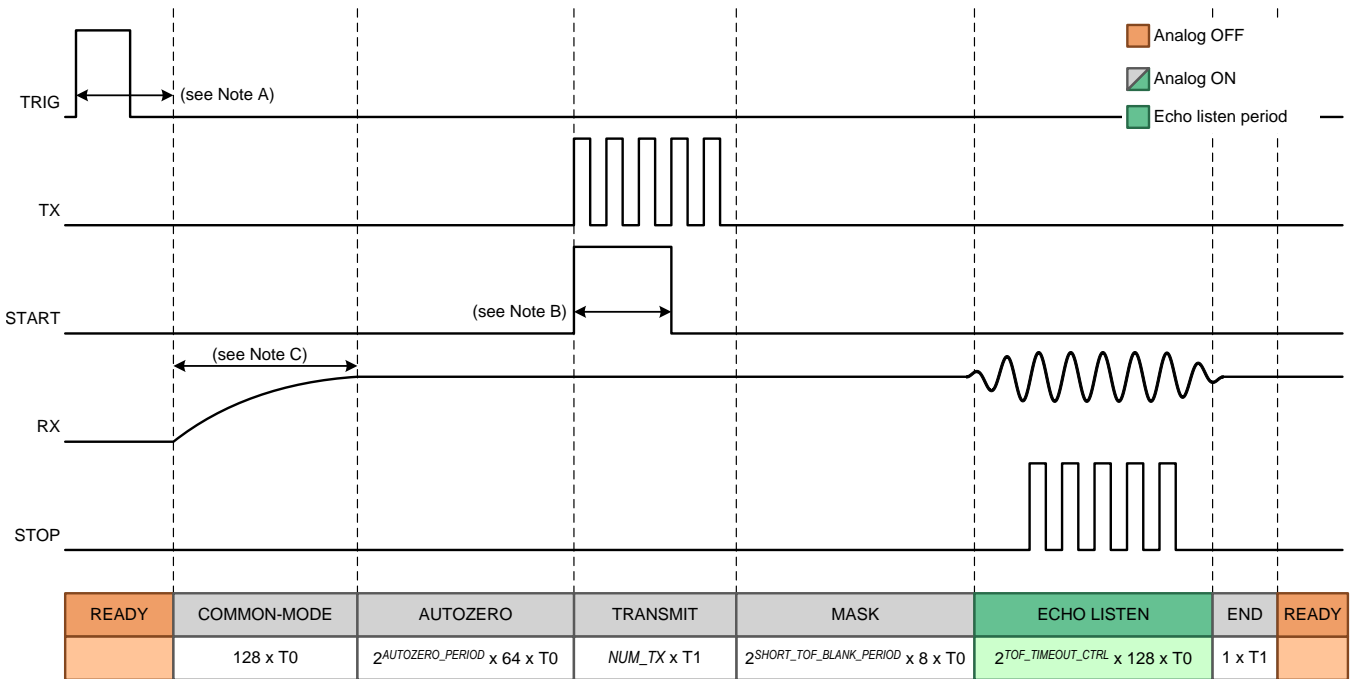

- A. Clock alignment (see [TX/RX Measurement Sequencing and Timing](#))
- B. If $\text{NUM_TX} < 3$, the width of the START pulse is equal to $\text{NUM_TX} \times T1$. If $\text{NUM_TX} \geq 3$, the width of the START pulse is equal to $3 \times T1$.
- C. Common-mode settling time.

Figure 37. Short TOF Measurement

In a short time of flight measurement, the RX path is activated before the TX burst, as shown in [Figure 37](#). The input MUX is automatically swapped to the alternate receive channel before and during the TX burst. Swapping the input prevents the TX burst from being amplified in the RX path. After the TX burst, the input MUX remains switched to the alternate channel for a masking period determined by the $\text{SHORT_TOF_BLANK_PERIOD}$ field in the [TIMEOUT](#) register. Masking the RX path avoids the issue of amplifying the transducer's residual TX ringing in the RX path.

The short TOF is the default measurement sequence selected at power-on. The short TOF measurement is selected if the value of the $\text{TIMING_REG}[9:0]$ field is less than 30, or if the FORCE_SHORT_TOF bit is set to 1. The $\text{TIMING_REG}[9:0]$ is a 10-bit wide field, with its 2 most significant bits located in the [TOF_1](#) register, and the 8 least significant bits located in the [TOF_0](#) register. The FORCE_SHORT_TOF bit is located in the [TIMEOUT](#) register.

The comparator's input offset is stored in an internal capacitor during the auto-zero period. The length of the auto-zero period is controlled by the AUTOZERO_PERIOD field in the [CLOCK_RATE](#) register.

The length of the window when the comparators are able to qualify and generate STOP pulses is configured by the TOF_TIMEOUT_CTRL field. A timeout will occur if the number of expected pulses is not received during the allocated time and an error condition is reported to the [ERROR_FLAGS](#) register and the ERRB pin. It is possible to disable the echo timeout (see [TOF Measurement Interval](#)). The TOF_TIMEOUT_CTRL field is located in the [TIMEOUT](#) register.

See the [Timing Control and Frequency Scaling \(CLKIN\)](#) section for the definition of the time periods T0 and T1.

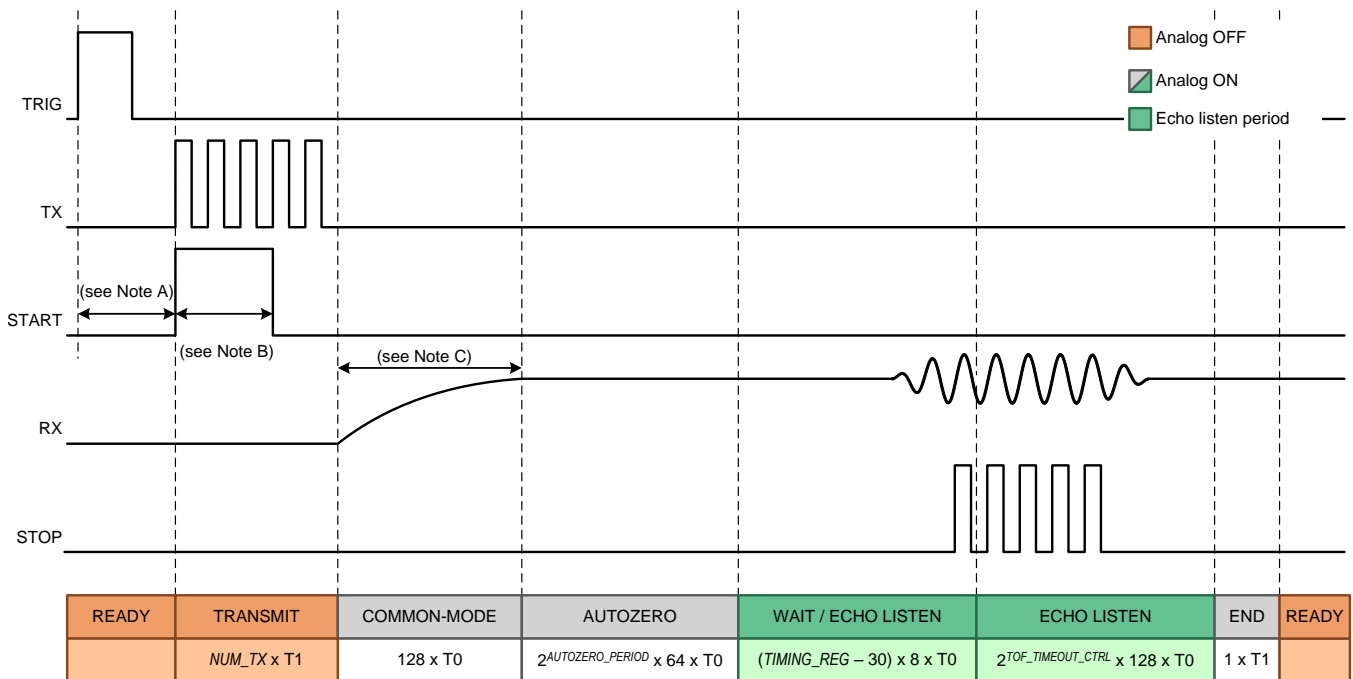
8.4.6.2 Standard TOF Measurement

- A. Clock alignment (see [TX/RX Measurement Sequencing and Timing](#))
- B. If $NUM_TX < 3$, the width of the START pulse is equal to $NUM_TX \times T1$. If $NUM_TX \geq 3$, the width of the START pulse is equal to $3 \times T1$.
- C. Common-mode settling time.

Figure 38. Standard TOF Measurement

In a standard time of flight measurement, the RX path is activated after the TX burst is completed, as shown in [Figure 38](#).

The standard TOF measurement sequence is enabled if the value of the *TIMING_REG* field is greater than or equal to 30, and only if the *FORCE_SHORT_TOF* bit is set to 0. The *TIMING_REG* is a 10-bit wide field, with its 2 most significant bits located in the *TOF_1* register, and the 8 least significant bits located in the *TOF_0* register. The *FORCE_SHORT_TOF* bit is located in the [TIMEOUT](#) register.

The comparator's input offset is stored in an internal capacitor during the auto-zero period. The length of the auto-zero period is controlled by the *AUTOZERO_PERIOD* field in the [CLOCK_RATE](#) register.

The length of the window when the comparators are able to qualify and generate STOP pulses is configured by a combination of the *TIMING_REG* field and the *TOF_TIMEOUT_CTRL* field. With the addition of the *TIMING_REG* in the calculation, the standard TOF measurement allows for a longer wait time and listening window. A timeout will occur if the number of expected pulses is not received during the allocated time and an error condition is reported to the [ERROR_FLAGS](#) register and the ERRB pin. It is possible to disable the echo timeout (see [TOF Measurement Interval](#)). The *TOF_TIMEOUT_CTRL* field is located in the [TIMEOUT](#) register.

NOTE

If the *FORCE_SHORT_TOF* bit = 1, the measurement sequencing will behave as a [Short TOF Measurement](#), thus overriding the setting of the *TIMING_REG* field.

8.4.6.3 Standard TOF Measurement with Power Blanking

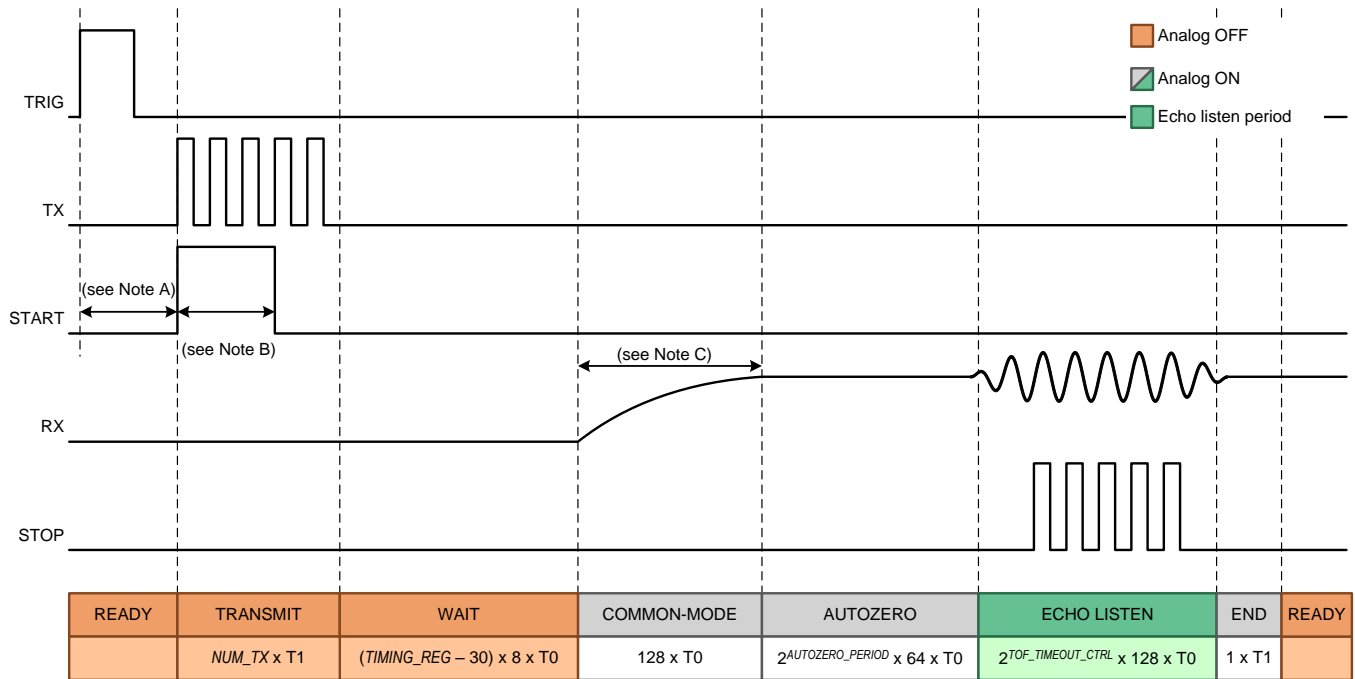

- A. Clock alignment (see [TX/RX Measurement Sequencing and Timing](#))
- B. If $NUM_TX < 3$, the width of the START pulse is equal to $NUM_TX \times T1$. If $NUM_TX \geq 3$, the width of the START pulse is equal to $3 \times T1$.
- C. Common-mode settling time.

Figure 39. Standard TOF Measurement with Blanking Enabled

The power blanking sequence is a variation to the standard TOF measurement sequence, and can be enabled by setting the *BLANKING* bit to 1. In addition, all other conditions described in the [Standard TOF Measurement](#) should be met. The *BLANKING* bit can be found in the [CONFIG_3](#) register.

Power blanking allows the device to remain in a low-power state while the TX signals propagate to the RX transducer in situations when the expected time-of-flight is long. Power blanking uses the *TIMING_REG* to control a wait time between the transmit sequence and the receive sequence, during which, the complete RX chain is disabled, as shown in [Figure 39](#). The *TIMING_REG* is a 10-bit wide field, with its 2 most significant bits located in the [TOF_1](#) register, and the 7 least significant bits located in the [TOF_0](#) register.

8.4.6.4 Common-mode Reference Settling Time

The duration of the common-mode settling *time* is defined by the VCOM capacitor. With a 10-nF VCOM capacitor, the common-mode reference requires 16 μ s to settle. On the other hand, the duration of the common-mode settling *window* is defined as $128 \times T0$, where the time unit $T0$ is determined by the external clock frequency and the value of the *CLOCKIN_DIV* bit, as explained in the [Timing Control and Frequency Scaling \(CLKIN\)](#) section.

A frequency of 8 MHz will result in a settling *window* of $128 \times 1 / 8$ MHz, which equals to 16 μ s. Increasing the value of the VCOM capacitor will increase the common-mode settling *time*, but for the same 8-MHz frequency, the duration of the common-mode settling *window* will remain at 16 μ s. In such situation, the common-mode reference will take multiple TOF cycles to reach its final value when starting from zero initial conditions.

8.4.6.5 TOF Measurement Interval

The comparators in the TDC1000's RX path can qualify and generate STOP pulses from a received echo within an interval set by the *TOF_TIMEOUT_CTRL* field in the [TIMEOUT](#) register. The listening interval can be extended in the standard TOF measurement (without blanking) by a period controlled with the *TIMING_REG* field (see [Standard TOF Measurement](#)).

If the number of STOP events programmed in the *NUM_RX* field is not received within the listening interval, a timeout event will occur and the device will return to the READY state. In addition, an error will be reported to the [ERROR_FLAGS](#) register and the ERRB pin will be driven low.

The echo timeout can be disabled by setting the *ECHO_TIMEOUT* bit to 1 in the [TIMEOUT](#) register. If the echo timeout is disabled, the device will not exit from the receive state until the expected number of STOP events set in *NUM_RX* occur. If the number of events does not occur, the device can be forced out of the receive state by writing a value of 0x03 to the [ERROR_FLAGS](#) register, or by de-asserting the EN pin, or asserting the RESET pin.

NOTE

Writing a logic 1 to bit [1] of the [ERROR_FLAGS](#) register clears the state machine. Writing a logic 1 to bit[0] clears the error flags.

NOTE

It is not recommended to hold the RX in an active state for intervals longer than 100ms, as the comparator auto-zero may no longer be accurate.

8.4.7 Averaging and Channel Selection

The TDC1000 supports averaging when configured in measurement Mode 2 (see [Time-of-Flight Measurement Mode](#)). Averaging is controlled with the *NUM_AVG* field located in the [CONFIG_1](#) register. In Mode 2, the TDC1000 will remain on the channel indicated by *CH_SEL* for $2^{\text{NUM_AVG}}$ trigger cycles. If *CH_SWP* is enabled in the [CONFIG_2](#) register, the TDC1000 will automatically swap the active channel and repeat the averaging cycle.

NOTE

If the bit [1] in the [ERROR_FLAGS](#) register is written to 1, the TDC1000 will reset its internal averaging counter and the software channel selection.

8.4.8 Error Reporting

The TDC1000 will report an error when the receive signals do not match the expected configuration. The ERRB pin will go low to indicate the presence of an error condition. Reading the [ERROR_FLAGS](#) register provides information about the condition(s) that caused the error.

The *ERR_SIG_WEAK* bit indicates that the number of received and qualified zero-crossings was less than the expected number set in the *NUM_RX* register field and a timeout occurred. This error is cleared when bit [0] is written to 1.

The *ERR_NO_SIG* bit indicates that no signals were received and a timeout occurred. Writing a 1 to this bit resets the state machine, halts active measurements and returns the device to SLEEP or READY mode and resets the average counter and automatic channel selection in measurement Mode 2. This error is cleared when bit [0] is written to 1.

The *ERR_SIG_HIGH* bit indicates that the received echo amplitude exceeds the largest echo qualification threshold at the input of the comparators. The *ERR_SIG_HIGH* error is only reported when the *ECHO_QUAL_THDL* register field is set to 7h. Writing a 1 to this bit will reset all the error flags and reset the ERRB pin to high.

NOTE

It is recommended to reset the state machine when the error flags are cleared. This can be done simultaneously by writing a value of 0x03 to the [ERROR_FLAGS](#) register.

8.5 Programming

8.5.1 Serial Peripheral Interface (SPI)

The serial interface consists of serial data input (SDI), serial data output (SDO), serial interface clock (SCLK) and chip select bar (CSB). The serial interface is used to configure the TDC1000 parameters available in various configuration registers. All the registers are organized into individually addressable byte-long registers with a unique address.

The communication on the SPI bus normally supports write and read transactions. A write transaction consists of a single write command byte, followed by single data byte. A read transaction consists of a single read command byte followed by 8 SCLK cycles. The write and read command bytes consist of 1 reserved bit, a 1-bit instruction, and a 6-bit register address. Figure 40 shows the SPI protocol for a transaction involving one byte of data (read or write).

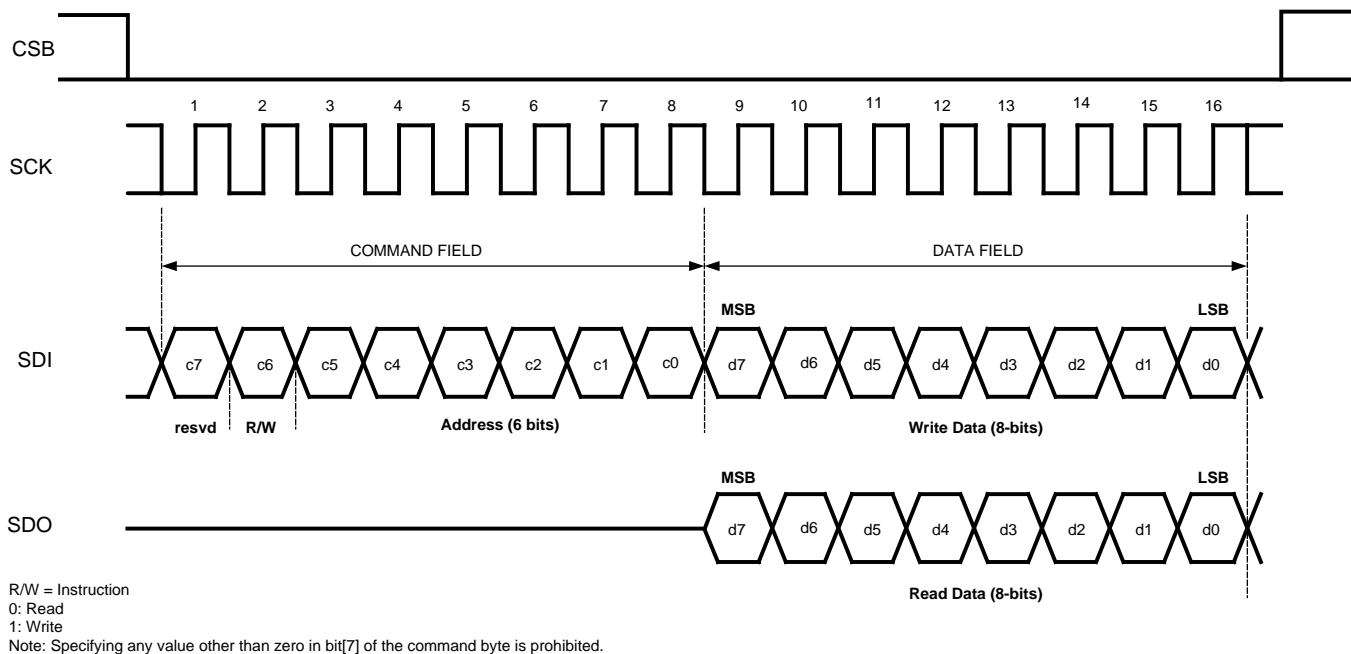

Figure 40. SPI Protocol

8.5.1.1 Chip Select Bar (CSB)

CSB is an active-low signal and needs to be low throughout a transaction. That is, CSB should not pulse between the command byte and the data byte of a single transaction.

De-asserting CSB always terminates an ongoing transaction, even if it is not yet complete. Re-asserting CSB will always bring the device into a state ready for the next transaction, regardless of the termination status of a previous transaction.

8.5.1.2 Serial Clock (SCLK)

SCLK can idle high or low. It is recommended to keep SCLK as clean as possible to prevent glitches from corrupting the SPI frame.

8.5.1.3 Serial Data Input (SDI)

SDI is driven by the SPI master by sending the command and the data byte to configure the AFE.

8.5.1.4 Serial Data Output (SDO)

SDO is driven by the AFE when the SPI master initiates a read transaction.

8.6 Register Maps

NOTE

- Reserved bits must be written to 0 unless otherwise indicated.
- Read-back value of reserved bits and registers is unspecified and should be discarded.
- Recommended values must be programmed and forbidden values must not be programmed where they are indicated to avoid unexpected results.

8.6.1 TDC1000 Registers

Table 4 list the memory-mapped registers for the TDC1000. All register addresses not listed in Table 4 should be considered as reserved locations and the register contents should not be modified.

Table 4. TDC1000 REGISTERS

Address (Hex)	Acronym	Register Name	Reset Value	Section
0h	CONFIG_0	Config-0	45h	See here
1h	CONFIG_1	Config-1	40h	See here
2h	CONFIG_2	Config-2	0h	See here
3h	CONFIG_3	Config-3	3h	See here
4h	CONFIG_4	Config-4	1Fh	See here
5h	TOF_1	TOF-1	0h	See here
6h	TOF_0	TOF-0	0h	See here
7h	ERROR_FLAGS	Error Flags	0h	See here
8h	TIMEOUT	Timeout	19h	See here
9h	CLOCK_RATE	Clock Rate	0h	See here

8.6.1.1 CONFIG_0 Register (address = 0h) [reset = 45h] (map)

Figure 41. CONFIG_0 Register

(MSB) 7	6	5	4	3	2	1	0 (LSB)
TX_FREQ_DIV				NUM_TX			
R/W-2h				R/W-5h			

LEGEND: R/W = Read or write; R = Read only; R/W1C = Read or write 1 to clear

Table 5. CONFIG_0 Register Field Descriptions

Bit	Field	Type	Reset	Description
[7:5]	TX_FREQ_DIV ⁽¹⁾	R/W	2h	Frequency divider for TX clock and T1 0h: Divide by 2 1h: Divide by 4 2h: Divide by 8 (default) 3h: Divide by 16 4h: Divide by 32 5h: Divide by 64 6h: Divide by 128 7h: Divide by 256
[4:0]	NUM_TX	R/W	5h	Number of TX pulses in a burst, ranging from 0 to 31. 5h: 5 pulses (default)

(1) See [Timing Control and Frequency Scaling \(CLKIN\)](#) for the definition of the time period T1.

8.6.1.2 CONFIG_1 Register (address = 1h) [reset = 40h] (map)
Figure 42. CONFIG_1 Register

(MSB) 7	6	5	4	3	2	1	0 (LSB)
RESERVED		NUM_AVG			NUM_RX		
R/W-1h		R/W-0h			R/W-0h		

LEGEND: R/W = Read or write; R = Read only; R/W1C = Read or write 1 to clear

Table 6. CONFIG_1 Register Field Descriptions

Bit	Field	Type	Reset	Description
[7:6]	RESERVED	R/W	1h	1h: Reserved (default)
[5:3]	NUM_AVG	R/W	0h	Number of measurement cycles to average in stopwatch/MCU 0h: 1 measurement cycle (default) 1h: 2 measurement cycles 2h: 4 measurement cycles 3h: 8 measurement cycles 4h: 16 measurement cycles 5h: 32 measurement cycles 6h: 64 measurement cycles 7h: 128 measurement cycles
[2:0]	NUM_RX	R/W	0h	Number of expected receive events 0h: Do not count events (32 STOP pulses output) (default) 1h: 1 event (1 STOP pulse output) 2h: 2 events (2 STOP pulses output) 3h: 3 events (3 STOP pulses output) 4h: 4 events (4 STOP pulses output) 5h: 5 events (5 STOP pulses output) 6h: 6 events (6 STOP pulses output) 7h: 7 events (7 STOP pulses output)

8.6.1.3 CONFIG_2 Register (address = 2h) [reset = 0h] (map)
Figure 43. CONFIG_2 Register

(MSB) 7	6	5	4	3	2	1	0 (LSB)
VCOM_SEL	MEAS_MODE	DAMPING	CH_SWP	EXT_CHSEL	CH_SEL	TOF_MEAS_MODE	
R/W-0h	R/W-0h	R/W-0h	R/W-0h	R/W-0h	R/W-0h	R/W-0h	

LEGEND: R/W = Read or write; R = Read only; R/W1C = Read or write 1 to clear

Table 7. CONFIG_2 Register Field Descriptions

Bit	Field	Type	Reset	Description
[7]	VCOM_SEL	R/W	0h	Common-mode voltage reference control 0h: Internal (default) 1h: External
[6]	MEAS_MODE	R/W	0h	AFE measurement type 0h: Time-of-flight measurement (default) 1h: Temperature measurement
[5]	DAMPING	R/W	0h	TX burst damping 0h: Disable damping (default) 1h: Enable damping
[4]	CH_SWP	R/W	0h	Automatic channel swap in Mode 2 of operation. The setting is ignored if EXT_CHSEL = 1. 0h: Disable automatic channel swap (default) 1h: Enable automatic channel swap
[3]	EXT_CHSEL	R/W	0h	External channel select by CHSEL pin 0h: Disable external channel select (default). 1h: Enable external channel select EXT_CHSEL = 1 overrides the CH_SWP and CH_SEL settings.
[2]	CH_SEL	R/W	0h	Active TX/RX channel pair. 0h: Channel 1 (default) 1h: Channel 2 See Time-of-Flight Measurement Mode for channel definitions. The setting is ignored if EXT_CHSEL = 1.
[1:0]	TOF_MEAS_MODE	R/W	0h	Time-of-flight measurement mode 0h: Mode 0 (default) 1h: Mode 1 2h: Mode 2 3h: Reserved

8.6.1.4 CONFIG_3 Register (address 3h) [reset = 3h] (map)
Figure 44. CONFIG_3 Register

(MSB) 7	6	5	4	3	2	1	0 (LSB)
RESERVED	TEMP_MODE	TEMP_RTD_SEL	TEMP_CLK_DIV	BLANKING	ECHO_QUAL_THLD		
R/W-0h	R/W-0h	R/W-0h	R/W-0h	R/W-0h	R/W-3h		

LEGEND: R/W = Read or write; R = Read only; R/W1C = Read or write 1 to clear

Table 8. CONFIG_3 Register Field Descriptions

Bit	Field	Type	Reset	Description
[7]	RESERVED	R/W	0h	0h: Reserved (default)
[6]	TEMP_MODE	R/W	0h	Temperature measurement channels 0h: Measure REF, RTD1 and RTD2 (default) 1h: Measure REF and RTD1
[5]	TEMP_RTD_SEL	R/W	0h	RTD type 0h: PT1000 (default) 1h: PT500
[4]	TEMP_CLK_DIV	R/W	0h	Clock divider for temperature mode 0h: Divide by 8 (default) 1h: Use TX_FREQ_DIV
[3]	BLANKING	R/W	0h	Power blanking in standard TOF measurements. The blanking length is controlled with the TIMING_REG field (see Standard TOF Measurement with Power Blanking). 0h: Disable power blanking (default) 1h: Enable power blanking
[2:0]	ECHO_QUAL_THLD	R/W	3h	Echo qualification DAC threshold level with respect to V_{COM} 0h: -35 mV 1h: -50 mV 2h: -75 mV 3h: -125 mV (default) 4h: -220 mV 5h: -410 mV 6h: -775 mV 7h: -1500 mV

8.6.1.5 CONFIG_4 Register (address = 4h) [reset = 1Fh] (map)
Figure 45. CONFIG_4 Register

(MSB) 7	6	5	4	3	2	1	0 (LSB)
RESERVED	RECEIVE_MODE	TRIG_EDGE_POLARITY	TX_PH_SHIFT_POS				
R/W-0h	R/W-0h	R/W-0h	R/W-1Fh				

LEGEND: R/W = Read or write; R = Read only; R/W1C = Read or write 1 to clear

Table 9. CONFIG_4 Register Field Descriptions

Bit	Field	Type	Reset	Description
[7]	RESERVED	R/W	0h	0h: Reserved (default)
[6]	RECEIVE_MODE	R/W	0h	Receive echo mode 0h: Single echo (default) 1h: Multi echo
[5]	TRIG_EDGE_POLARITY	R/W	0h	Trigger edge polarity 0h: Rising edge (default) 1h: Falling edge
[4:0]	TX_PH_SHIFT_POS	R/W	1Fh	TX 180° pulse shift position, ranging from 0 to 31. 1Fh: Position 31 (default) It is not recommended to set TX_PH_SHIFT_POS to 0 or 1.

8.6.1.6 TOF_1 Register (address = 5h) [reset = 0h] (map)
Figure 46. TOF_1 Register

(MSB) 7	6	5	4	3	2	1	0 (LSB)
PGA_GAIN		PGA_CTRL		LNA_CTRL	LNA_FB	TIMING_REG[9:8]	
R/W-0h		R/W-0h		R/W-0h	R/W-0h	R/W-0h	

LEGEND: R/W = Read or write; R = Read only; R/W1C = Read or write 1 to clear

Table 10. TOF_1 Register Field Descriptions

Bit	Field	Type	Reset	Description
[7:5]	PGA_GAIN	R/W	0h	PGA gain 0h: 0 dB (default) 1h: 3 dB 2h: 6 dB 3h: 9 dB 4h: 12 dB 5h: 15 dB 6h: 18 dB 7h: 21 dB
[4]	PGA_CTRL	R/W	0h	PGA control 0h: Active (default) 1h: Bypassed and powered off
[3]	LNA_CTRL	R/W	0h	LNA control 0h: Active (default) 1h: Bypassed and powered off
[2]	LNA_FB	R/W	0h	LNA feedback mode 0h: Capacitive feedback (default) 1h: Resistive feedback
[1:0]	TIMING_REG[9:8]	R/W	0h	TIMING_REG field's 2 most-significant bits (see Standard TOF Measurement and Standard TOF Measurement with Power Blanking) 0h: 0 (default)

8.6.1.7 TOF_0 Register (address = 6h) [reset = 0h] (map)
Figure 47. TOF_0 Register

(MSB) 7	6	5	4	3	2	1	0 (LSB)
TIMING_REG[7:0]							
R/W-0h							

LEGEND: R/W = Read or write; R = Read only; R/W1C = Read or write 1 to clear

Table 11. TOF_0 Register Field Descriptions

Bit	Field	Type	Reset	Description
[7:0]	TIMING_REG[7:0]	R/W	0h	TIMING_REG field's 8 least-significant bits (see Standard TOF Measurement and Standard TOF Measurement with Power Blanking) 0h: 0 (default)

8.6.1.8 ERROR_FLAGS Register (address = 7h) [reset = 0h] (map)
Figure 48. ERROR_FLAGS Register

7 (MSB)	6	5	4	3	2	1	0 (LSB)
RESERVED					ERR_SIG_WEAK	ERR_NO_SIG	ERR_SIG_HIGH
R-0h					R-0h	R/W1C-0	R/W1C-0

LEGEND: R/W = Read or write; R = Read only; R/W1C = Read or write 1 to clear

Table 12. ERROR_FLAGS Register Field Descriptions⁽¹⁾⁽²⁾

Bit	Field	Type	Reset	Description
[7:3]	RESERVED	R	0h	0h: Reserved (default)
[2]	ERR_SIG_WEAK	R	0h	1h: The number of received and qualified zero-crossings was less than the expected number set in NUM_RX field and a timeout occurred.
[1]	ERR_NO_SIG	R/W1C	0h	1h: No signals were received and timeout occurred. Writing a 1 to this field resets the state machine, halts active measurements and returns the device to the SLEEP or READY mode and resets the average counter and automatic channel selection in measurement Mode 2.
[0]	ERR_SIG_HIGH	R/W1C	0h	1h: The received echo amplitude exceeds the largest echo qualification threshold at the input of the comparators. The error is only reported when ECHO_QUAL_THLD = 0x07. Writing a 1 to this field will reset all the error flags and reset the ERRB pin to high.

(1) It is recommended to read the error status register or the ERRB pin before initiating a new measurement.

(2) All error flags should be cleared before initiating a new measurement.

8.6.1.9 TIMEOUT Register (address = 8h) [reset = 19h] (map)
Figure 49. TIMEOUT Register

(MSB) 7	6	5	4	3	2	1	0 (LSB)
RESERVED	FORCE_SHORT_TOF	SHORT_TOF_BLANK_PERIOD			ECHO_TIMEOUT	TOF_TIMEOUT_CTRL	
R/W-0h	R/W-0h	R/W-3h			R/W-0h	R/W-1h	

LEGEND: R/W = Read or write; R = Read only; R/W1C = Read or write 1 to clear

Table 13. TIMEOUT Register Field Descriptions

Bit	Field	Type	Reset	Description
[7]	RESERVED	R/W	0h	0h: Reserved (default)
[6]	FORCE_SHORT_TOF	R/W	0h	Short time-of-flight control 0h: Disabled (default) 1h: Force a short time-of-flight measurement
[5:3]	SHORT_TOF_BLANK_PERIOD ⁽¹⁾	R/W	3h	Short time-of-flight blanking period (see Short TOF Measurement) 0h: 8 × T ₀ 1h: 16 × T ₀ 2h: 32 × T ₀ 3h: 64 × T ₀ (default) 4h: 128 × T ₀ 5h: 256 × T ₀ 6h: 512 × T ₀ 7h: 1024 × T ₀
[2]	ECHO_TIMEOUT	R/W	0h	Echo receive timeout control (see TOF Measurement Interval) 0h: Enable echo timeout (default) 1h: Disable timeout
[1:0]	TOF_TIMEOUT_CTRL ⁽¹⁾	R/W	1h	Echo listening window timeout (see TOF Measurement Interval) 0h: 128 × T ₀ 1h: 256 × T ₀ (default) 2h: 512 × T ₀ 3h: 1024 × T ₀

(1) See [Timing Control and Frequency Scaling \(CLKIN\)](#) for the definition of the time period T₀.

8.6.1.10 CLOCK_RATE Register (address = 9h) [reset = 0h] (map)
Figure 50. CLOCK_RATE Register

(MSB) 7	6	5	4	3	2	1	0 (LSB)
RESERVED					CLOCKIN_DIV	AUTOZERO_PERIOD	
R/W-0h					R/W-0h	R/W-0h	

LEGEND: R/W = Read or write; R = Read only; R/W1C = Read or write 1 to clear

Table 14. CLOCK_RATE Register Field Descriptions⁽¹⁾

Bit	Field	Type	Reset	Description
[7:3]	RESERVED	R/W	0h	0h: Reserved (default)
[2]	CLOCKIN_DIV ⁽¹⁾	R/W	0h	CLKIN divider to generate T0 0h: Divide by 1 (default) 1h: Divide by 2
[1:0]	AUTOZERO_PERIOD ⁽¹⁾	R/W	0h	Receiver auto-zero period 0h: 64 × T0 (default) 1h: 128 × T0 2h: 256 × T0 3h: 512 × T0

 (1) See [Timing Control and Frequency Scaling \(CLKIN\)](#) for the definition of the time period T0.

9 Application and Implementation

NOTE

Information in the following applications sections is not part of the TI component specification, and TI does not warrant its accuracy or completeness. TI's customers are responsible for determining suitability of components for their purposes. Customers should validate and test their design implementation to confirm system functionality.

9.1 Application Information

The TDC1000 is an analog front-end for ultrasonic sensing applications. The device is typically used for the driving and sensing of ultrasonic transducers to perform accurate time-of-flight measurements. Ultrasonic time-of-flight sensing allows for fluid level measurements, fluid identification or concentration, flow measurements, and proximity/distance sensing.

9.2 Typical Applications

9.2.1 Level and Fluid Identification Measurements

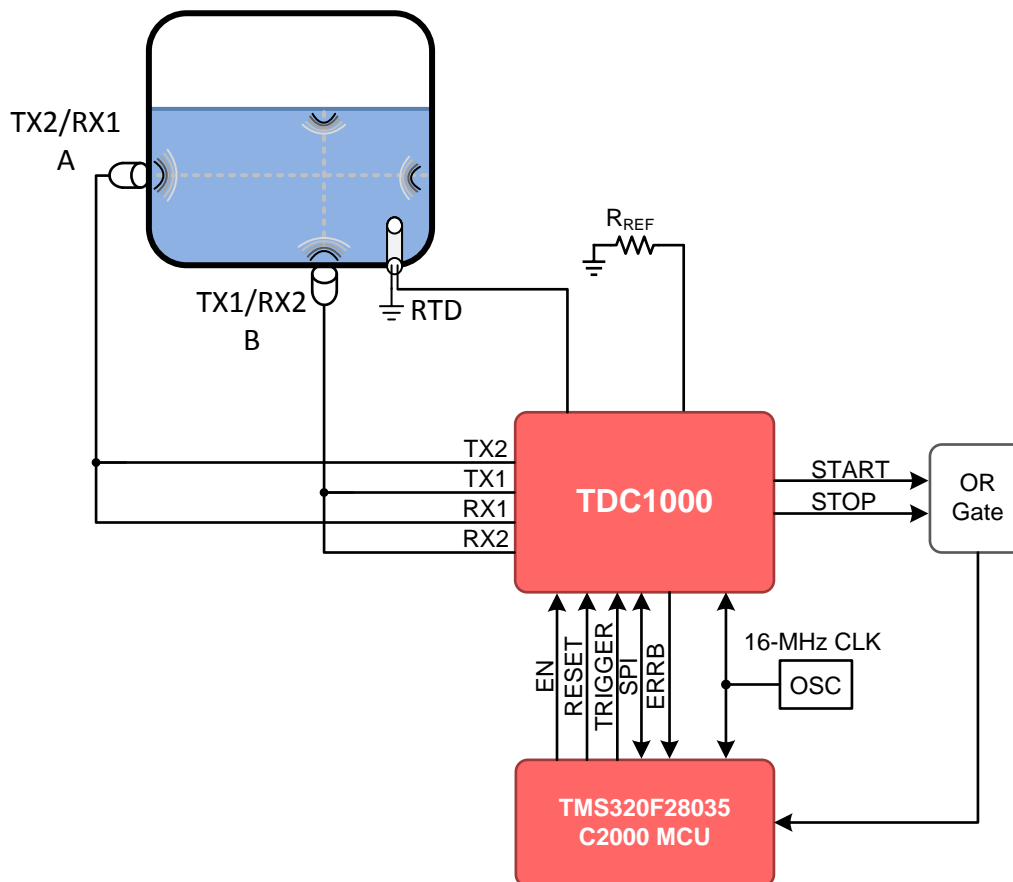

Figure 51. Level and Concentration Measurement Application Diagram

Typical Applications (continued)

9.2.1.1 Design Requirements

Table 15. Design Parameters

DESIGN PARAMETER	EXAMPLE VALUE
Fluid Level	
Range	2 – 10 cm
Fluid Identification	
Accuracy	0.5% concentration variation
Distance	5.08 cm

9.2.1.2 Detailed Design Procedure

9.2.1.2.1 Level Measurements

For level sensing applications, the total time-of-flight (TOF) of the sound wave in the fluid is measured. The pulses transmitted by transducer B travel through the fluid, typically from the bottom, to the surface of the fluid. The discontinuity between the fluid and air generates a reflected wave which returns back to transducer B.

At the beginning of a measurement cycle, the transducer is connected to a transmit channel of the AFE, and the transmit burst excites the transducer to generate an ultrasound wave. Synchronous to the TX burst, a START pulse is generated by the TDC1000 to indicate the start of a measurement. After the transmission is completed, and depending on the device configuration, the transducer is connected to a receive channel of the AFE.

When a valid echo is received, the TDC1000 generates a STOP pulse. Generation of multiple STOP pulses is possible through register configuration of the device. The START and STOP signal times are compared to determine the TOF.

The level of the fluid can be determined using the following equation:

$$d = \frac{TOF \times c}{2}$$

where

- d is the fluid level in meters (m)
 - TOF is the time-of-flight in seconds (s)
 - c is the speed of sound in the fluid in meters per second (m/s)
- (6)

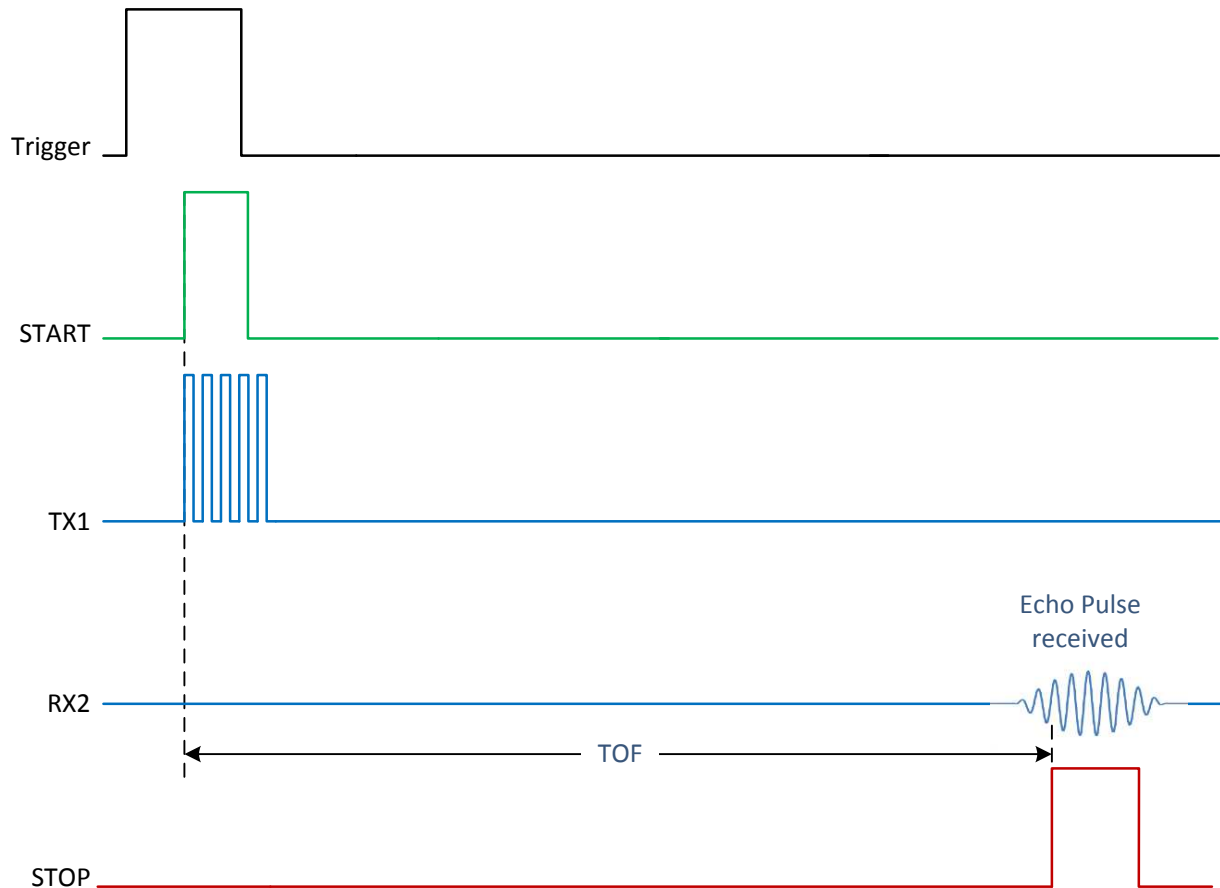

Figure 52. Relation Between Transmit and Receive Pulses in Level Measurements

Level measurements have 2 main criteria: resolution and range (maximum height). Resolution accuracies of 1-2 mm are achievable but are impractical due to any environmental disturbances, such as tank vibrations, creating millimeter level surface waves. Ranges of up to 1 m are measurable utilizing VDD level excitation pulses, but surface disturbances and signal loss over longer distances make the reliable echo reception an issue. Greater level measurement reception can be achieved by mechanical means (level guide tube) and/or electronic means (level shifting the TX pulses to greater voltages; see [TIDA-00322](#)).

9.2.1.2.2 Fluid Identification

The TDC1000 can be used to measure the time-of-flight for a known distance to calculate the speed of sound (c_{medium}) in the fluid. This application utilizes the same circuitry as the level example but a transducer in a different configuration connected to the second channel. In this example, the speed of sound in the fluid (c_{medium}) is measured by using transducer A.

The temperature can also be measured to compensate for the temperature variation of sound. With the known distance, TOF and temperature, the speed of sound in the fluid can be determined and the identity of the medium verified.

After measuring the time-of-flight for the fixed distance, the speed of sound can be calculated as follows:

$$c_{medium} = \frac{2 \times d}{TOF}$$

where

- c_{medium} is the speed of sound in the fluid in meters per second (m/s)
- d is the level in meters (m)
- TOF is the time of flight in seconds (s)

(7)

The measurement process is identical to the level example above. The speed of sound can be used to uniquely identify a variety of fluids. In this example, the concentration of diesel exhaust fluid (DEF) is measured with a desired accuracy resolution of 0.5% of concentration variation. For most fluids, the speed of sound varies over temperature, so every application will be different. In this example, all samples were all at ambient temperature of 23°C.

9.2.1.3 Application Curves

The data used in the following level and fluid identification graphs was collected using ultrasonic test cells. The test cells are acrylic plastic containers with width of 2.54 cm and ultrasonic transducers attached to the outside using cyanoacrylate glue. The transducers in this experiment are STEMiNC 1MHz piezo electric ceramic discs (SMD10T2R111). Equivalent transducers with the following characteristics could be used:

- Piezo material: SM111
- Dimensions: 10mm diameter x 2mm thickness
- Resonant frequency: 1050 kHz (thickness mode)

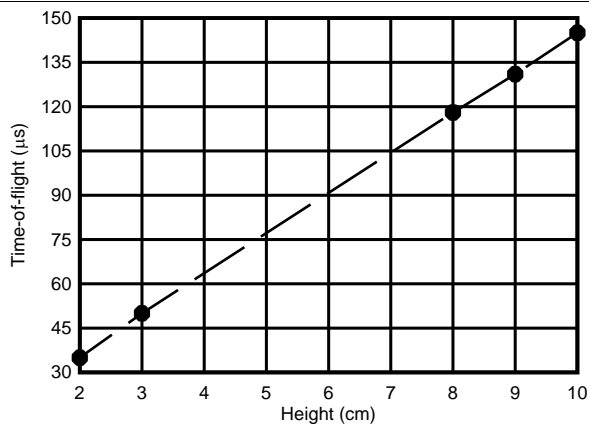

Fluid Height in Tank	Time-of-Flight (µs)
Full (10 cm)	145
Full – 1 (9 cm)	131
Full – 2 (8 cm)	118
3 cm	50
2 cm	35

Figure 53. Time-of-Flight for Fluid Height in Tank

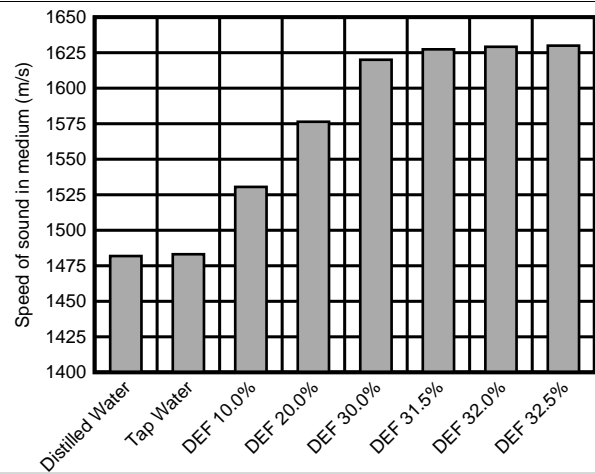

Fluid	Speed of sound (m/s)
Distilled water	1481.87
Tap water	1483.13
DEF 10.0%	1530.49
DEF 20.0%	1576.42
DEF 30.0%	1620.00
DEF 31.5%	1627.37
DEF 32.0%	1629.15
DEF 32.5%	1630.00

Figure 54. Speed of Sound for Various Fluids and Diesel Exhaust Fluid (DEF) Concentration

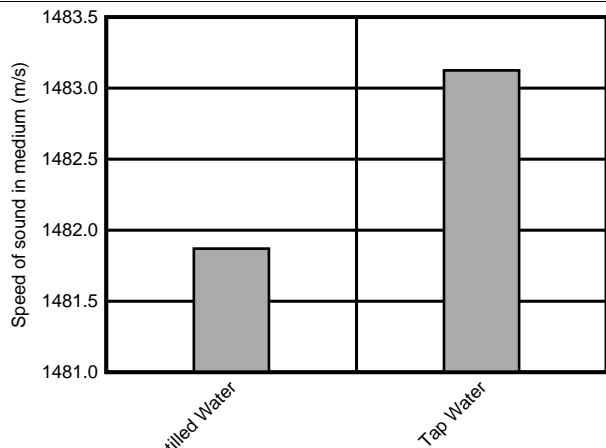

Fluid	Speed of sound (m/s)
Distilled water	1481.87
Tap water	1483.13

Figure 55. Speed of Sound in Distilled Water and Tap Water

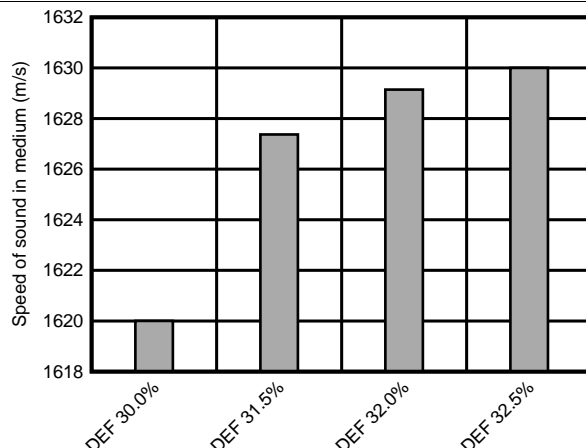

Fluid	Speed of sound (m/s)
DEF 30.0%	1620.00
DEF 31.5%	1627.37
DEF 32.0%	1629.15
DEF 32.5%	1630.00

Figure 56. Speed of Sound of Various Diesel Exhaust Fluid (DEF) Concentrations

9.2.2 Water Flow Metering

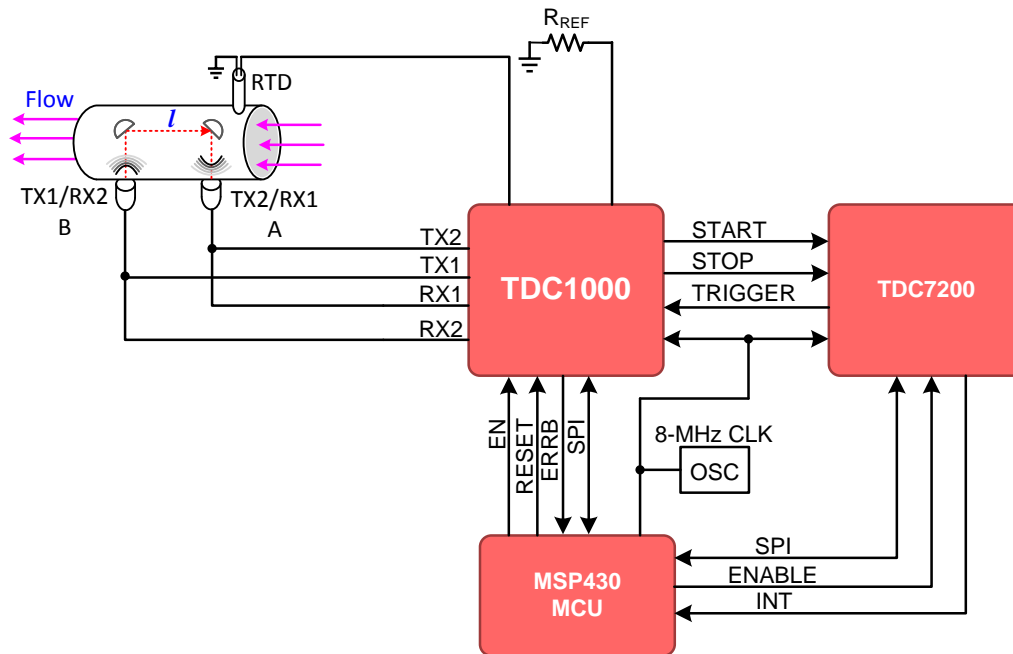

Figure 57. Water Flow-meter Application Simplified Diagram

9.2.2.1 Design Requirements

The parameters in [Table 16](#) are considered for this example.

Table 16. Design Parameters

DESIGN PARAMETER	EXAMPLE VALUE
Pipe diameter	15 mm
Distance between transducers	60 mm
Minimum flow rate	0.015 m ³ /h
Accuracy at minimum flow rate	5%

9.2.2.2 Detailed Design Procedure

The design of flow-meters requires a thorough technical assessment of the system where the device will be used. The following is a list of areas to consider:

- Minimum and maximum flow rate at maximum allowable error in the system
- Transitional flow rate
- Instantaneous and total quantity pumped over time
- Accuracy of the meter within prescribed limits per applicable standards
- Pressure in the system
- Operating temperature range

The appropriate ultrasonic sensor and the proper electronics for interfacing to the sensor are determined based on the system requirements. The following is a list of specifications applicable to the sensor/assembly used in the system:

- Excitation frequency
- Excitation source voltage
- Pipe diameter
- Distance between the transducers (or reflectors)

9.2.2.2.1 Regulations and Accuracy

If the flow meter is intended for residential applications, it must be designed to meet the required standards. For example, per the INTERNATIONAL ORGANIZATION OF LEGAL METROLOGY (OIML), the metrological requirements of water meters are defined by the values of Q1, Q2, Q3 and Q4, which are described in [Table 17](#).

Table 17. Flow-rate Zones per OIML

FLOW-RATE ZONE	DESCRIPTION
Q1	Lowest flow rate at which the meter is to operate within the maximum permissible errors.
Q2	Flow rate between the permanent flow rate and the minimum flow rate that divides the flow rate range into two zones, the upper flow rate zone and the lower flow rate zone, each characterized by its own maximum permissible errors.
Q3	Highest flow rate within the rated operating condition at which the meter is to operate within the maximum permissible errors.
Q4	Highest flow rate at which the meter is to operate for a short period of time within the maximum permissible errors, while maintaining its metrological performance when it is subsequently operating within the rated operating conditions.

A water meter is designated by the numerical value of Q3 in m³/h and the ratio Q3/Q1. The value of Q3 and the ratio of Q3/Q1 are selected from the lists provided in the OIML standards.

Water meters have to be designed and manufactured such that their errors do not exceed the maximum permissible errors (MPE) defined in the standards. For example, in OIML standards, water meters need to be designated as either accuracy class 1 or accuracy class 2, according to the requirements.

For class 1 water meters, the maximum permissible error in the upper flow rate zone ($Q2 \leq Q \leq Q4$) is $\pm 1\%$, for temperatures from 0.1°C to 30°C, and $\pm 2\%$ for temperatures greater than 30°C. The maximum permissible error for the lower flow-rate zone ($Q1 \leq Q < Q2$) is $\pm 3\%$, regardless of the temperature range.

For class 2 water meters, the maximum permissible error for the upper flow rate zone ($Q2 \leq Q \leq Q4$) is $\pm 2\%$, for temperatures from 0.1°C to 30°C, and $\pm 3\%$ for temperatures greater than 30°C. The maximum permissible error for the lower flow rate zone ($Q1 \leq Q < Q2$) is $\pm 5\%$ regardless of the temperature range.

The flow meter accuracy specified in the standards dictates the required accuracy in the electronics used for driving the ultrasonic transducers, circuits in the receiver path, and time measurement sub circuits. The stringent accuracy required at lower flow rates would require a very low noise signal chain in the transmitter and receiver circuits used in ultrasonic flow meters, as well as the ability to measure picosecond time intervals.

9.2.2.2.2 Transit-Time in Ultrasonic Flow-Meters

Transit-time ultrasonic flow meters works based on the principle that sound waves in a moving fluid travel faster in the direction of flow (downstream), and slower in the opposite direction of flow (upstream).

The system requires at least two transducers. The first transducer operates as a transmitter during the upstream cycle and as a receiver during the downstream cycle, and the second transducer operates as a receiver during the upstream cycle and as a transmitter during the downstream cycle. An ultrasonic flow meter operates by alternating transmit and receive cycles between the pair of transducers and accurately measuring the time-of-flight both directions.

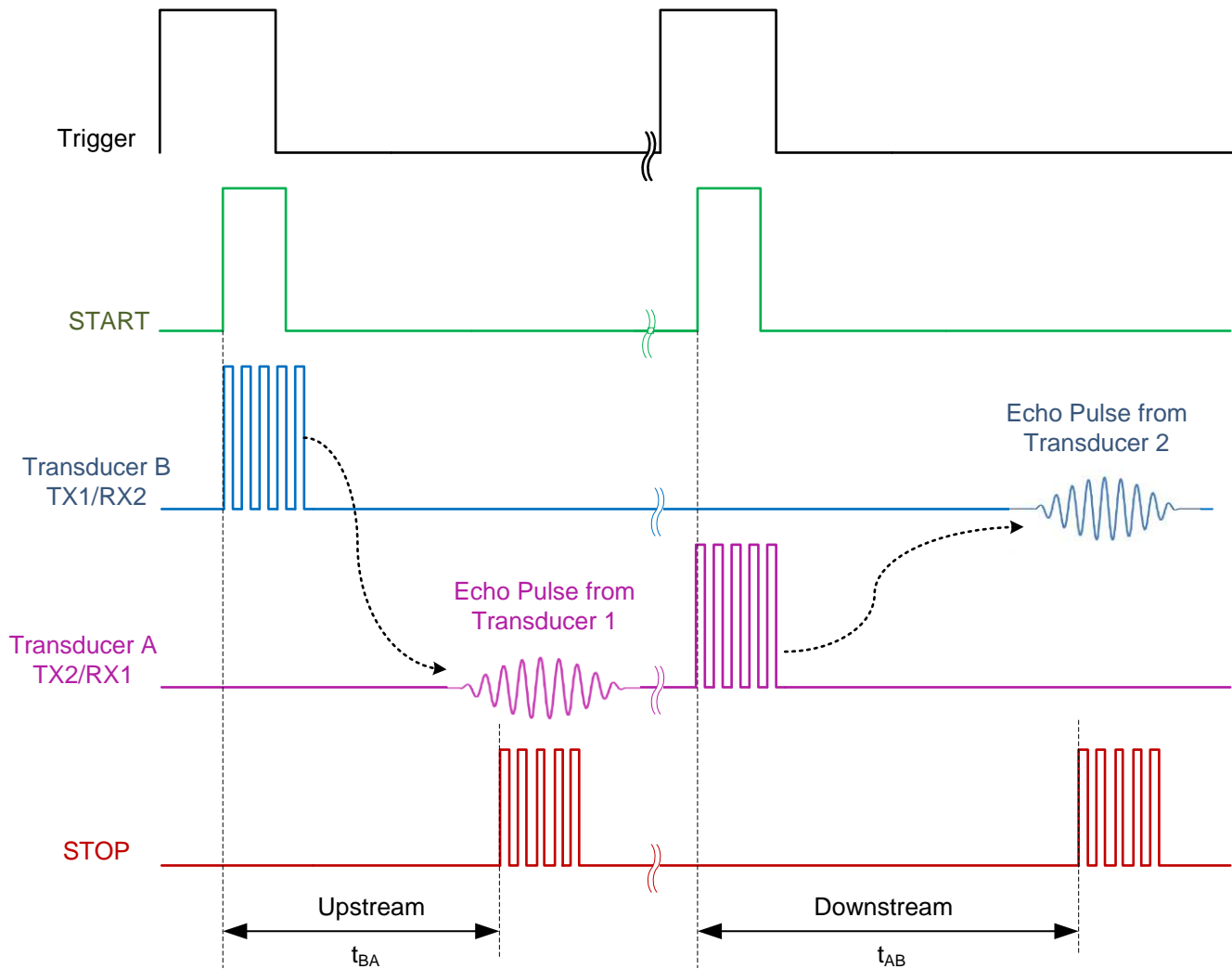

Figure 58. Relation Between Transmit and Receive Pulses Upstream/Downstream

In this example, the upstream TOF is defined as:

$$t_{BA} = \frac{l}{(c - v)}$$

where

- l is the path length between the two transducers in meters (m)
 - c is the speed of sound in water in meters per second (m/s)
 - v is the velocity of the water in the pipe in meters per second (m/s)
- (8)

In this example, the downstream TOF is defined as:

$$t_{AB} = \frac{l}{(c + v)}$$

where

- l is the path length between the two transducers in meters (m)
 - c is the speed of sound in water in meters per second (m/s)
 - v is the velocity of the water in the pipe in meters per second (m/s)
- (9)

The difference of TOF is defined as:

$$\Delta TOF = t_{BA} - t_{AB}$$

where

- t_{BA} is the upstream TOF from transducer B to transducer A in seconds (s)
- t_{AB} is the downstream TOF from transducer A to transducer B in seconds (s) (10)

After the difference in time-of-flight (ΔTOF) is calculated, the water velocity inside the pipe can be related to the ΔTOF using the following equation:

$$v = \frac{\Delta TOF \times c^2}{2 \times l}$$

where

- c is the speed of sound in water in meters per second (m/s)
- l is the path length between the two transducers in meters (m) (11)

Finally, the mass flow rate can be calculated as follows:

$$Q = k \times v \times A$$

where

- k is the flow-meter constant
- v is the velocity of the water in the pipe in meters per second (m/s)
- A is the cross-section area of the pipe in meters-squared (m^2) (12)

9.2.2.2.3 ΔTOF Accuracy Requirement Calculation

Based on the minimum mass flow requirement and accuracy requirements in [Table 16](#), the ΔTOF accuracy needed can be calculated as follows:

1. Convert the mass flow rate to m^3/s :

$$Q = (0.015 \text{ m}^3/\text{h}) \left(\frac{1 \text{ h}}{3600 \text{ s}} \right) = 4.167 \times 10^{-6} \text{ m}^3/\text{s}$$

2. Calculate the flow velocity assuming $k = 1$:

$$v = \frac{Q}{kA} = \frac{4.167 \times 10^{-6} \text{ m}^3/\text{s}}{\pi \left(\frac{0.015 \text{ m}}{2} \right)^2} = 0.0236 \text{ m/s}$$

3. Calculate the ΔTOF for the given speed of sound. In this example, a speed of sound $c = 1400 \text{ m/s}$ is assumed:

$$\Delta TOF = \frac{2 \times l \times v}{c^2} = \frac{(2)(0.06 \text{ m})(0.0236 \text{ m/s})}{1400 \text{ m/s}^2} = 1.445 \text{ ns}$$

4. The requirement of 5% accuracy for minimum flow will result in a ΔTOF accuracy of:

$$\Delta TOF_{\text{error}} = (0.05)(1.445 \text{ ns}) = 72.25 \text{ ps}$$

For this reason, this system requires a high accuracy timer/stopwatch that can measure the lower flow rate state.

9.2.2.2.4 Operation

The TDC1000 is used to drive the transmitter, amplify and filter the received signal and conditioning the echo for START and STOP pulse generation. The TDC7200 ps-accurate timer is used to measure the time interval between the rising edge of the START pulse and the rising edge of the STOP pulse produced by the TDC1000.

The microcontroller should first configure the TDC7200 and the TDC1000 for the measurement. When the microcontroller issues a start command to the TDC7200 via the SPI interface, the TDC7200 sends a trigger pulse to the TRIGGER pin of the TDC1000. When the TDC1000 drives the transmit transducer, a synchronous START pulse is produced on the START pin, which commands the TDC7200 to start its counters. When a valid echo pulse is received on the receive transducer, the TDC1000 generates a STOP pulse on the STOP pin, which commands the TDC7200 to stop its counters. This procedure is repeated for the upstream and downstream cycles.

A temperature measurement can be performed and the result can be used to correct for temperature dependency of the speed of sound.

9.2.2.3 Application Curves

The following figures show data and histograms created with data collected under a zero flow condition at room temperature. A simple offset calibration has been applied, where the overall average of the data is subtracted from the data.

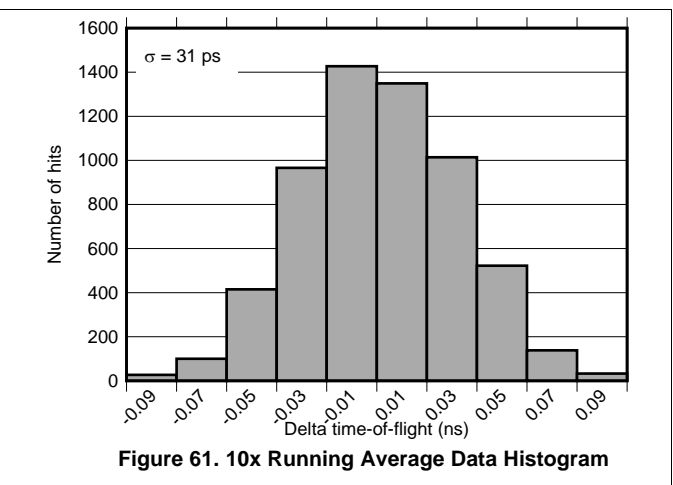
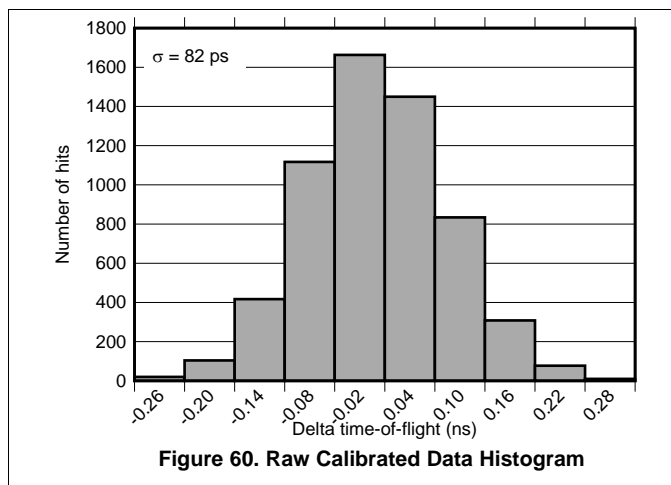
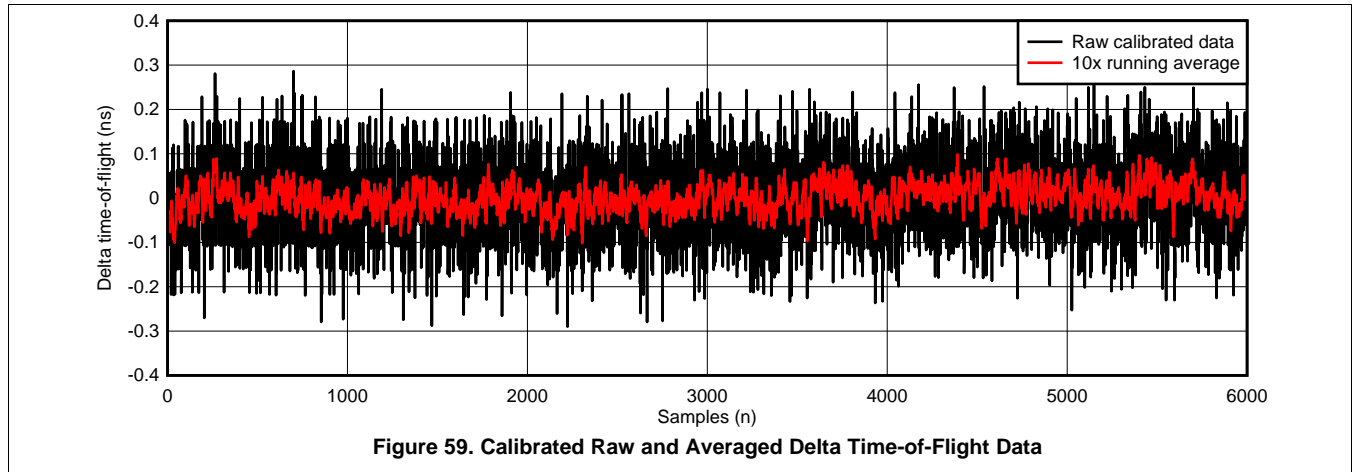

10 Power Supply Recommendations

The analog circuitry of the TDC1000 is designed to operate from an input voltage supply range between 2.7V and 5.5V. It is recommended to place a 100nF ceramic bypass capacitor to ground as close as possible to the VDD pins. In addition, an electrolytic or tantalum capacitor with value greater than 1 μ F is recommended. The bulk capacitor does not need to be in close vicinity with the TDC1000 and could be close to the voltage source terminals or at the output of the voltage regulators powering the TDC1000.

The IO circuitry of the TDC1000 is designed to operate from an input voltage supply range between 1.8V and 5.5V. The IO voltage supply (V_{IO}) can be lower than the analog voltage supply (V_{DD}), but it should not exceed it. It is also recommended to place a 100nF ceramic bypass capacitor to ground as close as possible to the VIO pin. If a separate source or regulator is used for VIO, an additional electrolytic or tantalum capacitor with value greater than 1 μ F is recommended.

In some cases an additional 10 μ F bypass capacitor may further reduce the supply noise.

11 Layout

11.1 Layout Guidelines

- In a 4-layer board design, the recommended layer stack order from top to bottom is: signal, ground, power and signal.
- Bypass capacitors should be placed in close proximity to the VDD and VIO pins.
- The length of the START and STOP traces from the DUT to the stopwatch/MCU should be matched to prevent uneven signal delays. Also, avoid unnecessary via-holes on these traces and keep the routing as short/direct as possible to minimize parasitic capacitance on the PCB.
- Match the length of the TX pair from the DUT to the transducers to prevent uneven signal delays from one channel direction to the other.
- Match the length of the RX pair from the transducers to the DUT to prevent uneven signal delays from one channel direction to the other.
- Match the length (or resistance) of the traces leading to the RTD sensors. PCB series resistance will be added in series to the RTD sensors.
- Route the SPI signal traces close together. Place a series resistor at the source of SDO (close to the DUT) and series resistors at the sources of SDI, SCLK and CSB (close to the master MCU).

11.2 Layout Example

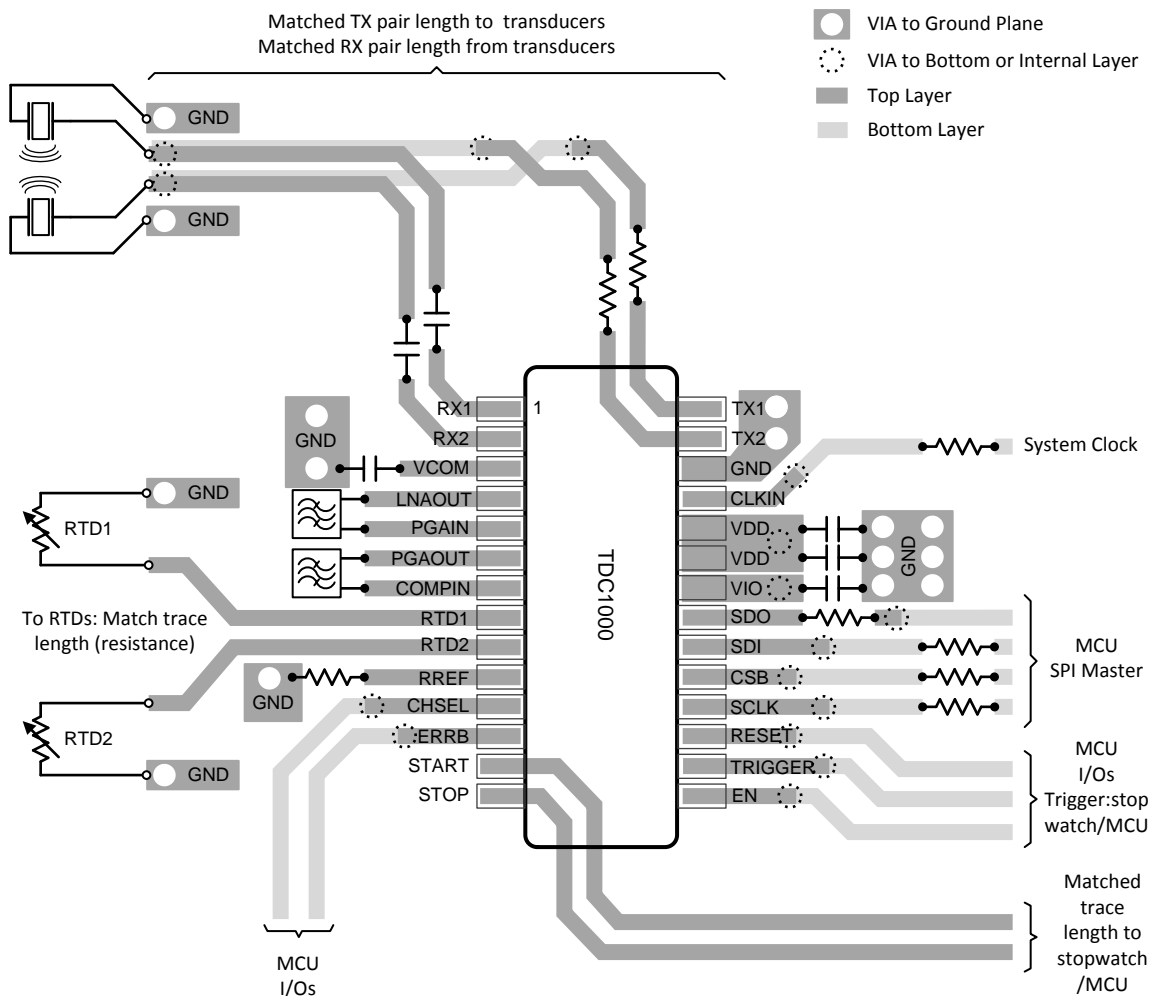

Figure 62. TDC1000 Board Layout (Capacitive Feedback Mode)

12 器件和文档支持

12.1 器件支持

12.1.1 Third-Party Products Disclaimer

TI'S PUBLICATION OF INFORMATION REGARDING THIRD-PARTY PRODUCTS OR SERVICES DOES NOT CONSTITUTE AN ENDORSEMENT REGARDING THE SUITABILITY OF SUCH PRODUCTS OR SERVICES OR A WARRANTY, REPRESENTATION OR ENDORSEMENT OF SUCH PRODUCTS OR SERVICES, EITHER ALONE OR IN COMBINATION WITH ANY TI PRODUCT OR SERVICE.

12.1.2 开发支持

相关开发支持请参阅以下文档:

- 《汽车类超声波液位/质量测量参考设计》， [TIDA-00322](#)

12.2 文档支持

相关文档请参见以下部分:

- 《TDC1000 温度感测接口》， [SNA218](#)

12.3 相关链接

下面的表格列出了快速访问链接。 范围包括技术文档、支持和社区资源、工具和软件，以及样片或购买的快速访问。

表 18. 相关链接

部件	产品文件夹	样片与购买	技术文档	工具与软件	支持与社区
TDC1000	请单击此处	请单击此处	请单击此处	请单击此处	请单击此处
TDC1000-Q1	请单击此处	请单击此处	请单击此处	请单击此处	请单击此处

12.4 社区资源

The following links connect to TI community resources. Linked contents are provided "AS IS" by the respective contributors. They do not constitute TI specifications and do not necessarily reflect TI's views; see TI's [Terms of Use](#).

TI E2E™ Online Community *TI's Engineer-to-Engineer (E2E) Community*. Created to foster collaboration among engineers. At e2e.ti.com, you can ask questions, share knowledge, explore ideas and help solve problems with fellow engineers.

Design Support *TI's Design Support* Quickly find helpful E2E forums along with design support tools and contact information for technical support.

12.5 商标

E2E is a trademark of Texas Instruments.

All other trademarks are the property of their respective owners.

12.6 静电放电警告



这些装置包含有限的内置 ESD 保护。 存储或装卸时，应将导线一起截短或将装置放置于导电泡棉中，以防止 MOS 门极遭受静电损伤。

12.7 Glossary

[SLYZ022](#) — *TI Glossary*.

This glossary lists and explains terms, acronyms, and definitions.

13 机械、封装和可订购信息

以下页中包括机械、封装和可订购信息。 这些信息是针对指定器件可提供的最新数据。 这些数据会在无通知且不对本文档进行修订的情况下发生改变。 欲获得该数据表的浏览器版本，请查阅左侧的导航栏。

PACKAGING INFORMATION

Orderable Device	Status (1)	Package Type	Package Drawing	Pins	Package Qty	Eco Plan (2)	Lead finish/ Ball material (6)	MSL Peak Temp (3)	Op Temp (°C)	Device Marking (4/5)	Samples
TDC1000PW	ACTIVE	TSSOP	PW	28	48	RoHS & Green	SN	Level-1-260C-UNLIM	-40 to 125	TDC1000PW	Samples
TDC1000PWR	ACTIVE	TSSOP	PW	28	2500	RoHS & Green	SN	Level-1-260C-UNLIM	-40 to 125	TDC1000PW	Samples
TDC1000QPWQ1	ACTIVE	TSSOP	PW	28	48	RoHS & Green	SN	Level-1-260C-UNLIM	-40 to 125	TDC1000 PWQ1	Samples
TDC1000QPWRQ1	ACTIVE	TSSOP	PW	28	2500	RoHS & Green	SN	Level-1-260C-UNLIM	-40 to 125	TDC1000 PWQ1	Samples

(1) The marketing status values are defined as follows:

ACTIVE: Product device recommended for new designs.

LIFEBUY: TI has announced that the device will be discontinued, and a lifetime-buy period is in effect.

NRND: Not recommended for new designs. Device is in production to support existing customers, but TI does not recommend using this part in a new design.

PREVIEW: Device has been announced but is not in production. Samples may or may not be available.

OBSELETE: TI has discontinued the production of the device.

(2) **RoHS:** TI defines "RoHS" to mean semiconductor products that are compliant with the current EU RoHS requirements for all 10 RoHS substances, including the requirement that RoHS substance do not exceed 0.1% by weight in homogeneous materials. Where designed to be soldered at high temperatures, "RoHS" products are suitable for use in specified lead-free processes. TI may reference these types of products as "Pb-Free".

RoHS Exempt: TI defines "RoHS Exempt" to mean products that contain lead but are compliant with EU RoHS pursuant to a specific EU RoHS exemption.

Green: TI defines "Green" to mean the content of Chlorine (Cl) and Bromine (Br) based flame retardants meet JS709B low halogen requirements of <=1000ppm threshold. Antimony trioxide based flame retardants must also meet the <=1000ppm threshold requirement.

(3) MSL, Peak Temp. - The Moisture Sensitivity Level rating according to the JEDEC industry standard classifications, and peak solder temperature.

(4) There may be additional marking, which relates to the logo, the lot trace code information, or the environmental category on the device.

(5) Multiple Device Markings will be inside parentheses. Only one Device Marking contained in parentheses and separated by a "-" will appear on a device. If a line is indented then it is a continuation of the previous line and the two combined represent the entire Device Marking for that device.

(6) Lead finish/Ball material - Orderable Devices may have multiple material finish options. Finish options are separated by a vertical ruled line. Lead finish/Ball material values may wrap to two lines if the finish value exceeds the maximum column width.

Important Information and Disclaimer:The information provided on this page represents TI's knowledge and belief as of the date that it is provided. TI bases its knowledge and belief on information provided by third parties, and makes no representation or warranty as to the accuracy of such information. Efforts are underway to better integrate information from third parties. TI has taken and

continues to take reasonable steps to provide representative and accurate information but may not have conducted destructive testing or chemical analysis on incoming materials and chemicals. TI and TI suppliers consider certain information to be proprietary, and thus CAS numbers and other limited information may not be available for release.

In no event shall TI's liability arising out of such information exceed the total purchase price of the TI part(s) at issue in this document sold by TI to Customer on an annual basis.

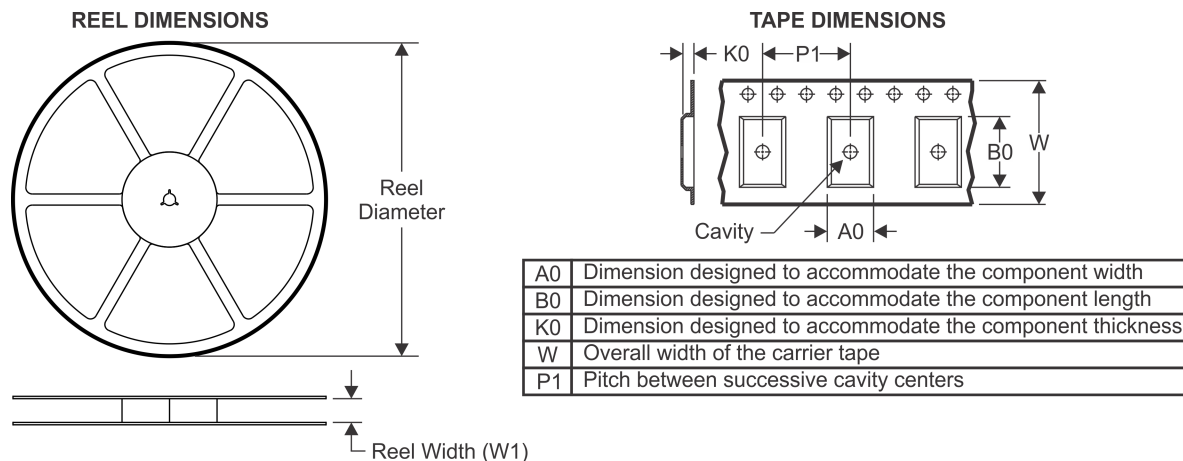
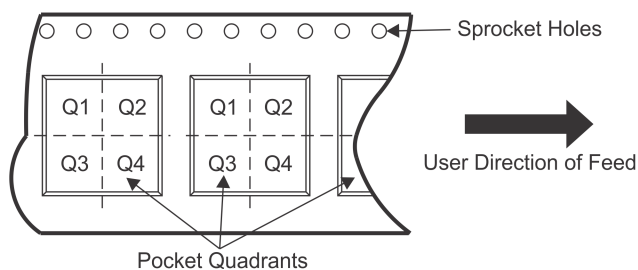
TAPE AND REEL INFORMATION

QUADRANT ASSIGNMENTS FOR PIN 1 ORIENTATION IN TAPE

*All dimensions are nominal

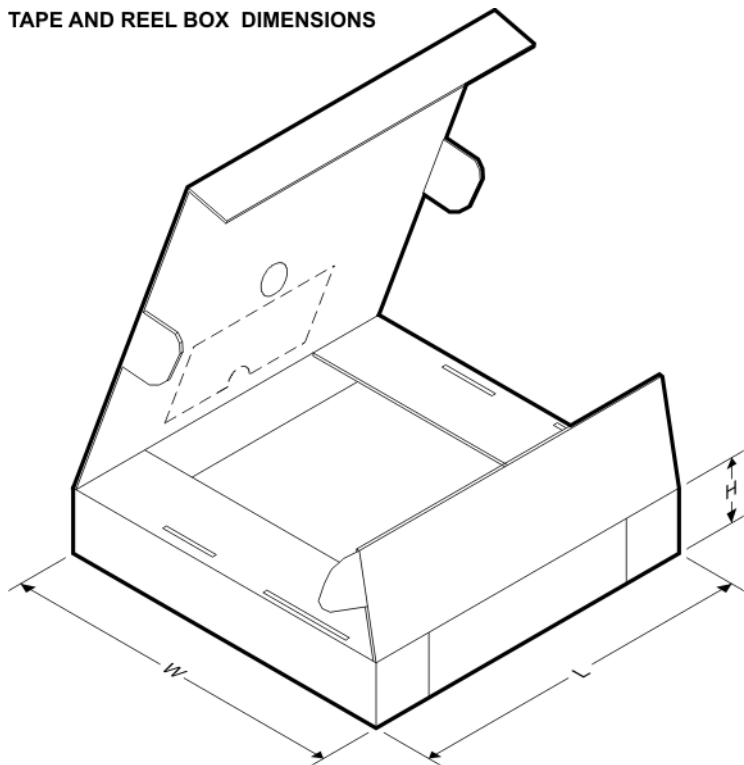
Device	Package Type	Package Drawing	Pins	SPQ	Reel Diameter (mm)	Reel Width W1 (mm)	A0 (mm)	B0 (mm)	K0 (mm)	P1 (mm)	W (mm)	Pin1 Quadrant
TDC1000PWR	TSSOP	PW	28	2500	330.0	16.4	6.8	10.2	1.6	8.0	16.0	Q1
TDC1000QPWRQ1	TSSOP	PW	28	2500	330.0	16.4	6.8	10.2	1.6	8.0	16.0	Q1

TAPE AND REEL BOX DIMENSIONS

*All dimensions are nominal

Device	Package Type	Package Drawing	Pins	SPQ	Length (mm)	Width (mm)	Height (mm)
TDC1000PWR	TSSOP	PW	28	2500	853.0	449.0	35.0
TDC1000QPWRQ1	TSSOP	PW	28	2500	367.0	367.0	35.0

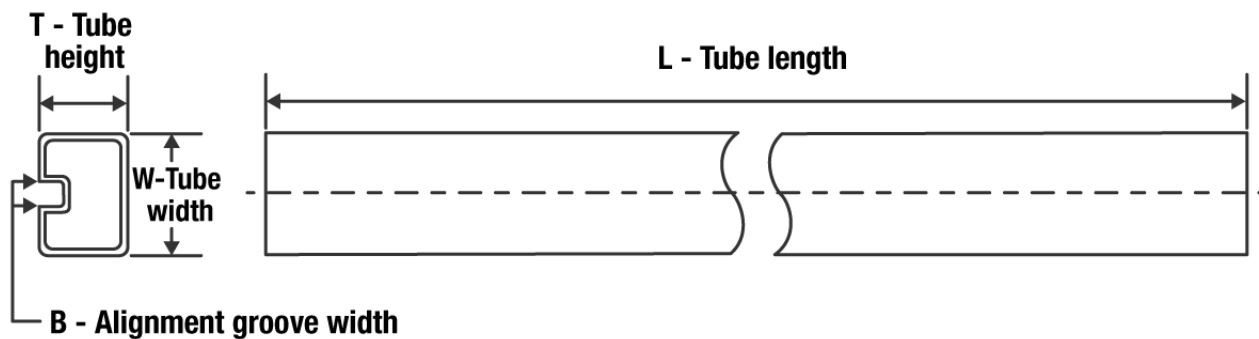
TUBE

*All dimensions are nominal



Device	Package Name	Package Type	Pins	SPQ	L (mm)	W (mm)	T (μm)	B (mm)
TDC1000PW	PW	TSSOP	28	48	495	8	2514.6	4.06
TDC1000QPWQ1	PW	TSSOP	28	48	495	8	2514.6	4.06

PW (R-PDSO-G28)

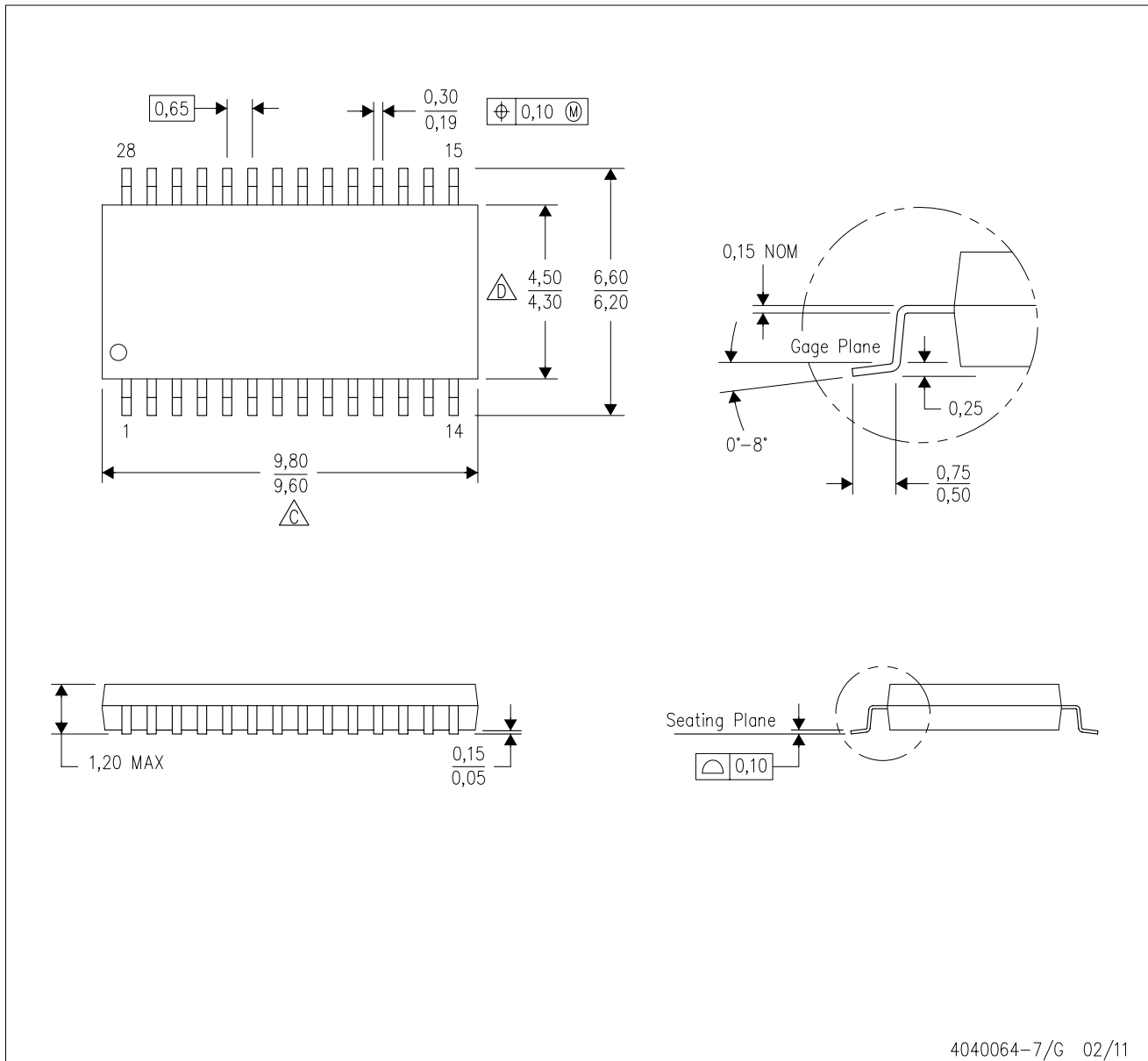
PLASTIC SMALL OUTLINE



4040064-7/G 02/11

- NOTES:
- A. All linear dimensions are in millimeters. Dimensioning and tolerancing per ASME Y14.5M-1994.
 - B. This drawing is subject to change without notice.
 -  C. Body length does not include mold flash, protrusions, or gate burrs. Mold flash, protrusions, or gate burrs shall not exceed 0,15 each side.
 -  D. Body width does not include interlead flash. Interlead flash shall not exceed 0,25 each side.
 - E. Falls within JEDEC MO-153

重要声明和免责声明

TI“按原样”提供技术和可靠性数据（包括数据表）、设计资源（包括参考设计）、应用或其他设计建议、网络工具、安全信息和其他资源，不保证没有瑕疵且不做任何明示或暗示的担保，包括但不限于对适销性、某特定用途方面的适用性或不侵犯任何第三方知识产权的暗示担保。

这些资源可供使用 TI 产品进行设计的熟练开发人员使用。您将自行承担以下全部责任：(1) 针对您的应用选择合适的 TI 产品，(2) 设计、验证并测试您的应用，(3) 确保您的应用满足相应标准以及任何其他功能安全、信息安全、监管或其他要求。

这些资源如有变更，恕不另行通知。TI 授权您仅可将这些资源用于研发本资源所述的 TI 产品的应用。严禁对这些资源进行其他复制或展示。您无权使用任何其他 TI 知识产权或任何第三方知识产权。您应全额赔偿因在这些资源的使用中对 TI 及其代表造成的任何索赔、损害、成本、损失和债务，TI 对此概不负责。

TI 提供的产品受 [TI 的销售条款](#) 或 [ti.com](#) 上其他适用条款/TI 产品随附的其他适用条款的约束。TI 提供这些资源并不会扩展或以其他方式更改 TI 针对 TI 产品发布的适用的担保或担保免责声明。

TI 反对并拒绝您可能提出的任何其他或不同的条款。

邮寄地址：Texas Instruments, Post Office Box 655303, Dallas, Texas 75265

Copyright © 2022，德州仪器 (TI) 公司