

TDP0604 6Gbps 直流或交流耦合型 HDMI™ 2.0 电平转换器混合转接驱动器

1 特性

- 支持高达 6Gbps HDMI 2.0 数据速率的交流耦合或直流耦合输入和输出
 - 向后兼容 HDMI 1.4b
- 支持双模 DisplayPort (DP++)
- 可编程的接收器均衡器在 3GHz 下高达 12dB
- I²C 或引脚搭接可编程
- 集成的 HPD 电平转换器同时支持 1.8V 和 3.3V LVCMOS 电平
- 集成的 DDC 缓冲器支持最低 1.2V 电平
- 主通道上全通道交换
- 用于链路配置的数字显示控制 (DDC) 监控功能
- 低功耗：
 - 6Gbps 有源限制：215mW
 - 关断 (HPD_IN = L)：0.55mW
- 可用于商业级和工业级温度范围
- 3.3V 单电源
- 40 引脚、0.4mm 间距、4mm × 6mm WQFN 封装

2 应用

- 笔记本电脑和台式机
- 电视
- 家庭影院和娱乐系统
- 游戏系统
- 扩展坞
- 专业音频、视频和标牌

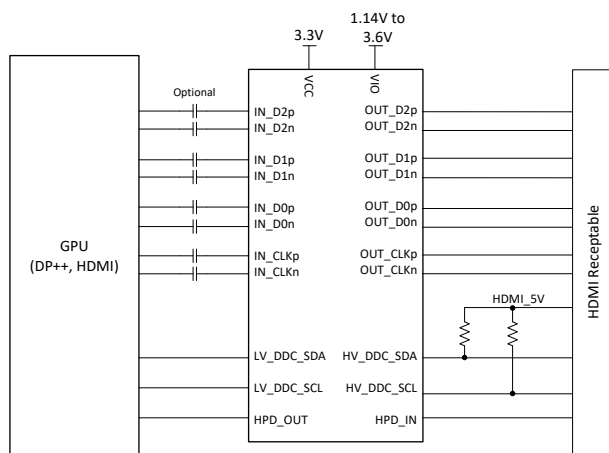

简化版原理图

3 说明

TDP0604 是一款 HDMI 2.0 转接驱动器，支持高达 6Gbps 的数据速率，向后兼容 HDMI 1.4b。高速差分输入和输出可以是交流耦合或直流耦合，从而支持将 TDP0604 用作 DP++ 转 HDMI 电平转换器或 HDMI 转接驱动器。

TDP0604 是一款混合转接驱动器，同时支持源端和接收端应用。混合转接驱动器可用作线性转接驱动器，也可用作限幅转接驱动器。配置为限幅转接驱动器时，TDP0604 的差分输出电压电平独立于图形处理单元 (GPU) 的输出电平，从而确保插座的 HDMI 电平符合要求。限幅转接驱动器模式推荐用于 HDMI 源端应用。配置为线性转接驱动器时，TDP0604 的差分输出电压是 GPU 输出电压的线性函数，从而支持将 TDP0604 用于透明呈现链路训练或用作通道缩短器。建议将线性转接驱动器模式用于 HDMI 接收端应用。

TDP0604 有一个集成的 HPD 电平转换器，该转换器可将 5V HPD 信号转换为 1.8V 或 3.3V。电平转换器输出还可配置为推挽式或开漏式。另外，TDP0604 还集成了一个数字显示控制 (DDC) 缓冲器。DDC 缓冲器可提供电容隔离，电平转换器可将 5V DDC 电平转换至最低 1.2V 电平。集成电平转换器后，无需分立式解决方案，因此节省了系统成本。

TDP0604 支持 3.3V V_{CC} 单电源轨，可用于商业级温度范围 (TDP0604) 和工业级温度范围 (TDP0604I)。

器件信息⁽¹⁾

器件型号	封装	封装尺寸 (标称值)
TDP0604	WQFN (40)	4.00mm × 6.00mm
TDP0604I		

- (1) 如需了解所有可用封装，请参阅数据表末尾的可订购产品附录。



Table of Contents

1 特性	1	8.5 Programming.....	37
2 应用	1	8.6 Register Maps.....	39
3 说明	1	9 Application and Implementation	49
4 Revision History	2	9.1 Application Information.....	49
5 Pin Configuration and Functions	3	9.2 Typical Source-Side Application.....	49
6 Specifications	6	10 Power Supply Recommendations	55
6.1 Absolute Maximum Ratings.....	6	10.1 Supply Decoupling.....	55
6.2 ESD Ratings.....	6	11 Layout	55
6.3 Recommended Operating Conditions.....	6	11.1 Layout Guidelines.....	55
6.4 Thermal Information.....	7	11.2 Layout Example.....	56
6.5 Electrical Characteristics.....	7	12 Device and Documentation Support	57
6.6 Timing Requirements.....	12	12.1 Documentation Support.....	57
6.7 Switching Characteristics.....	13	12.2 接收文档更新通知.....	57
6.8 Typical Characteristics.....	16	12.3 支持资源.....	57
7 Parameter Measurement Information	17	12.4 Trademarks.....	57
8 Detailed Description	22	12.5 Electrostatic Discharge Caution.....	57
8.1 Overview.....	22	12.6 术语表.....	57
8.2 Functional Block Diagram	23	13 Mechanical, Packaging, and Orderable Information	57
8.3 Feature Description.....	24		
8.4 Device Functional Modes.....	34		

4 Revision History

DATE	REVISION	NOTES
December 2021	*	Initial Release

5 Pin Configuration and Functions



图 5-1. RNQ Package, 40-Pin WQFN (Top View)

表 5-1. Pin Functions

PIN		TYPE ⁽¹⁾	DESCRIPTION
NAME	NO.		
VCC	1	P	3.3-V power supply
HPDOUT_SEL	2	I 2-Level (PD)	HPDOUT_SEL. Selects whether HPD_OUT pin is push/pull, or open-drain. Open-drain is not supported in pin-strap mode. Therefore this pin should be left floating or pull-down to GND.
TEST1	3	O	Test1. For internal Texas Instruments use only. This pin can be left unconnected.
CTLEMAP_SEL	4	I 4-Level (PU/PD)	CTLE Map select. When TDP0604 is configured in pin-strap mode, this pin selects the CTLE Map used. Refer to 表 8-7 for details. In I ² C mode, CTLE map is determined by registers.
LINEAR_EN	5	I 4-Level (PU/PD)	In pin-strap mode, selects whether TDP0604 operates in linear or limited redriver mode. Refer to 表 8-4.
VCC	6	P	3.3-V power supply.
EN	7	I 2-Level (PU)	When low, TDP0604 will be held in reset. The IN_D[2:0], IN_CLK, OUT_D[2:0] and OUT_CLK pins will be held in high impedance while EN is low. On rising edge of EN, device will sample 4-level inputs and function based on the sampled state of the pins. This pin has a internal 250k pull-up to VIO.
EQ1	8	I 4 Level (PU/PD)	EQ1 pin setting when TDP0604 is configured for pin strap mode; Works in conjunction with EQ0; See 表 8-5 for settings. In I ² C mode, EQ settings are controlled through the registers.
IN_D2p	9	I	Channel 2 differential positive input.

表 5-1. Pin Functions (continued)

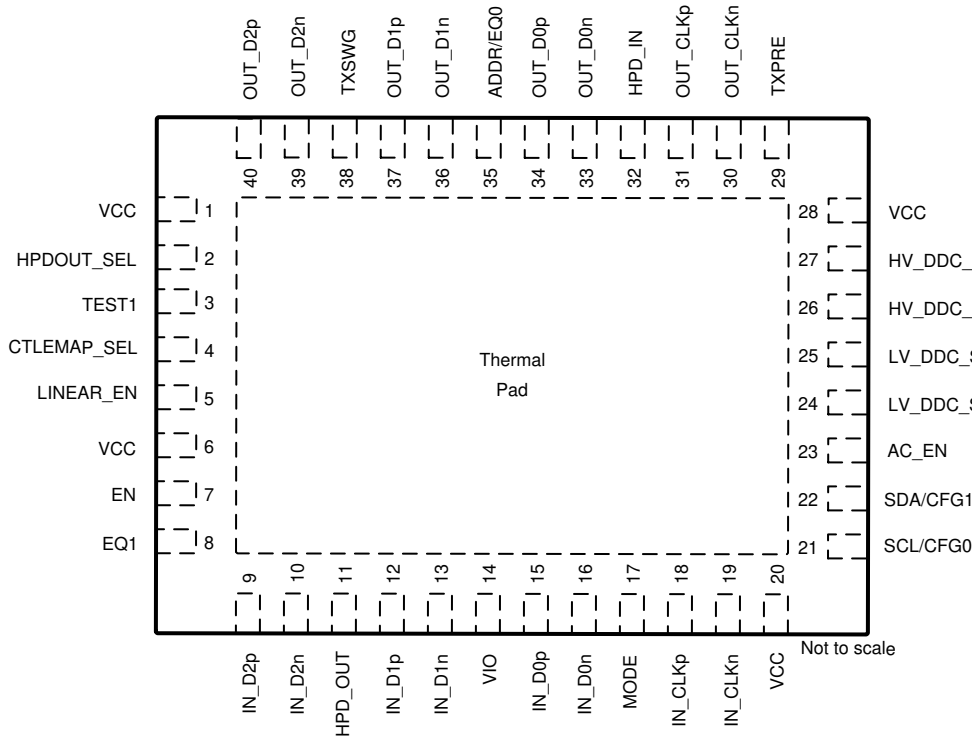
PIN		TYPE ⁽¹⁾	DESCRIPTION
NAME	NO.		
IN_D2n	10	I	Channel 2 differential negative input.
HPD_OUT	11	O	Hot plug detect output to source side. If not used, then this pin can be left floating. If used, then it is recommended to have a external 220k resistor to GND on this pin.
IN_D1p	12	I	Channel 1 differential positive input.
IN_D1n	13	I	Channel 1 differential negative input.
VIO	14	P	Voltage supply for I/Os. Refer to 表 8-2.
IN_D0p	15	I	Channel 0 differential positive input.
IN_D0n	16	I	Channel 0 differential negative input.
MODE	17	I 4-Level (PU/PD)	Mode control pin. Selects between pin-strap and I2C mode. Refer to 节 8.4.1.
IN_CLKp	18	I	Clock differential positive input.
IN_CLKn	19	I	Clock differential negative input.
VCC	20	P	3.3-V power supply.
SCL/CFG0	21	I	I ² C Clock/CFG0: When TDP0604 is configured for I ² C mode, this pin will function as the I ² C clock. Otherwise, this pin will function as CFG0 as detailed in 表 8-13.
SDA/CFG1	22	I/O	I ² C Data / CFG1: When TDP0604 is configured for I ² C mode, this pin will function as the I ² C clock. Otherwise, this pin will function as CFG1 as detailed in 表 8-14.
AC_EN	23	I 2-Level (PD)	In pin-strap mode, selects whether high speed transmitters are externally AC or DC-coupled. 0: DC-coupled 1: AC-coupled
LV_DDC_SCL	24	I/O	Low voltage side bidirectional DDC clock line. Internally pulled-up to VIO.
LV_DDC_SDA	25	I/O	Low voltage side bidirectional DDC data line. Internally pulled-up to VIO.
HV_DDC_SDA	26	I/O	High voltage side bidirectional DDC data line. Pull-up externally to HDMI 5 V.
HV_DDC_SCL	27	I/O	High voltage side bidirectional DDC clock line. Pull-up externally to HDMI 5 V.
VCC	28	P	3.3-V power supply.
TXPRE	29	I 4-Level (PU/PD)	TX pre-emphasis control: In pin-strap mode with limited enabled, this pin controls TX EQ. Refer to 表 8-11 for available TXPRE settings when operating in pin strap mode. In I ² C mode, TX pre-emphasis is controlled through the registers.
OUT_CLKn	30	O	TMDS data clock differential negative output
OUT_CLKp	31	O	TMDS data clock differential positive output
HPD_IN	32	I 2-Level (PD)	Hot plug detect input from sink side. This pin has an internal pull-down resistor and is fail-safe.
OUT_D0n	33	O	TMDS data 0 differential negative output
OUT_D0p	34	O	TMDS data 0 differential positive output
ADDR/EQ0	35	I 4-Level (PU/PD)	Address bit for I2C programming when TDP0604 is configured for I ² C mode. Refer to 表 8-18. EQ0 pin setting when TDP0604 is configured for pin strap mode; works in conjunction with EQ1; see 表 8-5 for settings. In I ² C mode, EQ settings are controlled through the registers.
OUT_D1n	36	O	TMDS data 1 differential negative output
OUT_D1p	37	O	TMDS data 1 differential positive output
TXSWG	38	I 4-Level (PU/PD)	TX output swing control: 4 settings. This pin is only used in pin strap mode. Refer to 表 8-12 for available TX swing settings. In I ² C mode, TX output swing is controlled through the registers.
OUT_D2n	39	O	TMDS data 2 differential negative output
OUT_D2p	40	O	TMDS data 2 differential positive output

表 5-1. Pin Functions (continued)

PIN		TYPE ⁽¹⁾	DESCRIPTION
NAME	NO.		
Thermal Pad	41	GND	Thermal pad. Connect to a solid ground plane.

(1) I = input, O = output, GND = ground, P = power, PU = pull-up, PD = pull-down

6 Specifications

6.1 Absolute Maximum Ratings

over operating free-air temperature range (unless otherwise noted)⁽¹⁾

		MIN	MAX	UNIT
Supply Voltage	V _{CC} and V _{IO}	-0.5	4	V
Input Voltage	Differential Inputs (IN_D[2:0], IN_CLK)	-0.3	4	V
Output voltage	HPD_OUT output	-0.3	4	V
Output voltage	Differential outputs (OUT_D[2:0], OUT_CLK)	-0.3	4	V
Control pins	LV_DDC_SDA, LV_DDC_SCL, SCL/CFG0, SDA/CFG1, MODE, CLTEMAP_SEL, HPDOUT_SEL, TXSWG, TXPRE, EQ1, ADDR/EQ0, EN, AC_EN, LINEAR_EN	-0.5	4	V
	HPD_IN	-0.5	6	V
T _J	TDP0604 Junction temperature		105	°C
T _J	TDP0604I Junction temperature		125	°C
T _{stg}	Storage temperature	-65	150	°C

- (1) Operation outside the *Absolute Maximum Rating* may cause permanent damage to the device. Absolute maximum ratings do not imply functional operation of the device at these or any other conditions beyond those listed under the *Recommended Operating Condition*. If briefly operating outside the *Recommended Operating Conditions* but within the *Absolute Maximum Ratings*, the device may not sustain damage, but it may not be fully functional. Operating the device in this manner may affect device reliability, functionality, performance, and shorten the device lifetime.

6.2 ESD Ratings

			VALUE	UNIT
V _(ESD)	Electrostatic discharge	Human body model (HBM), per ANSI/ESDA/ JEDEC JS-001, all pins ⁽¹⁾	±4000	V
		Charged device model (CDM), per ANSI/ESDA/ JEDEC JS-002, all pins ⁽²⁾	±1500	

- (1) JEDEC document JEP155 states that 500-V HBM allows safe manufacturing with a standard ESD control process.
 (2) JEDEC document JEP157 states that 250-V CDM allows safe manufacturing with a standard ESD control process.

6.3 Recommended Operating Conditions

over operating free-air temperature range (unless otherwise noted)

		MIN	NOM	MAX	UNIT
V _{CC}	Supply voltage when high-speed RX pins (IN_D[2:0] and IN_CLK) is AC-coupled to a DP++ TX	3.0	3.3	3.6	V
V _{CC}	Supply voltage when high-speed RX pins (IN_D[2:0] and IN_CLK) is DC-coupled to a HDMI TX	3.135	3.3	3.465	V
V _{IO}	VIO supply when 1.2-V LVCMOS level used.	1.14	1.2	1.26	V
V _{IO}	VIO supply when 1.8-V LVCMOS level used.	1.7	1.8	1.9	V
V _{IO}	VIO supply when 3.3-V LVCMOS level used.	3	3.3	3.6	V
V _{PSN}	Peak to peak Power supply noise on V _{CC} pins (less than 4 MHz).			100	mV
V _{CTL3}	DC input voltage for SCL/CFG0, SDA/CFG1, MODE, AC_EN, LINEAR_EN, EN, CTLEMAP_SEL, TXSWG, TXPRE, EQ1, ADDR1/EQ0, LV_DDC_SCL, LV_DDC_SDA, HPDOUT_SEL	-0.3		3.6	V
V _{CTL5}	DC input voltage for HV_DDC_SCL, HV_DDC_SDA, HPD_IN pins	-0.3		5.5	V
C _{ACRX}	Optional external AC-coupling capacitor on IN_Dx and IN_CLK.	85		253	nF
C _{ACTX}	External AC-coupling capacitor on OUT_Dx and OUT_CLK when AC_EN = H.	85		253	nF
T _A	TDP0604 Ambient temperature	0		70	°C

6.3 Recommended Operating Conditions (continued)

over operating free-air temperature range (unless otherwise noted)

		MIN	NOM	MAX	UNIT
T _A	TDP0604I Ambient temperature	- 40		85	°C

6.4 Thermal Information

THERMAL METRIC ⁽¹⁾		TDP0604		UNIT
		RNQ (WQFN)		
		40 PINS		
R _{θJA}	Junction-to-ambient thermal resistance	30.9		°C/W
R _{θJC(top)}	Junction-to-case (top) thermal resistance	21.2		°C/W
R _{θJB}	Junction-to-board thermal resistance	11.7		°C/W
Ψ _{JT}	Junction-to-top characterization parameter	0.3		°C/W
Ψ _{JB}	Junction-to-board characterization parameter	11.7		°C/W
R _{θJC(bot)}	Junction-to-case (bottom) thermal resistance	3.8		°C/W

(1) For more information about traditional and new thermal metrics, see the [Semiconductor and IC Package Thermal Metrics](#) application report.

6.5 Electrical Characteristics

over recommended voltage and operating free-air temperature range (unless otherwise noted)

PARAMETER		TEST CONDITIONS	MIN	TYP	MAX	UNIT
POWER						
P _{ACTIVE-H14-LT-ARX-DTX}	Power dissipation in HDMI 1.4 3.4 Gbps active operation	Pin Strap mode; DR = 3.4Gbps; HPD_IN = H; No de-emphasis/pre-emphasis; Limited redriver mode; DC-coupled TX; AC-coupled RX; 3GbpsCTLE;		190		mW
P _{ACTIVE-H20-LT-ARX-DTX}	Power dissipation in HDMI 2.0 6 Gbps active operation	Pin Strap mode; DR = 6Gbps; HPD_IN = H; No de-emphasis/pre-emphasis; Limited redriver mode; DC-coupled TX; AC-coupled RX; 6GbpsCTLE;		215		mW
P _{PD}	Power in power-down (HPD_IN = L)	Pin Strap mode; HPD_IN = L; EN = L or H; High-speed outputs are disconnected;		0.55		mW
P _{SD}	Power in standby (HPD_IN = H) but no incoming signal with DDC Buffer disabled	Pin Strap mode; HPD_IN = H; No incoming signal; EN = H; DC-coupled TX; AC-coupled RX; Limited redriver mode; High-speed outputs are connected;		1.0		mW
P _{SD}	Power in standby (HPD_IN = H) but no incoming signal with DDC buffer enabled.	Pin Strap mode; HPD_IN = H; No incoming signal; EN = H; DC-coupled TX; AC-coupled RX; Limited redriver mode; High-speed outputs are connected;		1.2		mW
I _{VIOQ}	VIO quiescent current	HPD_IN = H; VCC = VIO = 3.6V; LV_DDC_SDA/SCL = H;			16	μA
I _{VIOA}	VIO active instantaneous current	VCC = VIO = 3.6V; HPD_IN = H;			1	mA
2-LEVEL CONTROL PINS (EN, SCL/CFG0, SDA/CFG1, AC_EN)						
V _{IO_TRSH D}	Threshold for selecting between 1.2-V LVCMOS / 1.8-V LVCMOS			1.5		V
V _{IO_TRSH D}	Threshold for selecting between 1.8-V LVCMOS / 3.3-V LVCMOS			2.5		V
V _{IL_1p2V}	Low-level input voltage for SCL/CFG0, SDA/CFG1	VIO = 1.26V; VCC = 3.0V;	-0.3		0.378	V
V _{IH_1p2V}	High-level input voltage for SCL/CFG0, SDA/CFG1	VIO = 1.14V; VCC = 3.6V;	0.8		3.6	V

6.5 Electrical Characteristics (continued)

over recommended voltage and operating free-air temperature range (unless otherwise noted)

PARAMETER		TEST CONDITIONS	MIN	TYP	MAX	UNIT
V_{IL_1p8V}	Low-level input voltage for SCL/CFG0, SDA/CFG1	$V_{IO} = 1.9V$; $V_{CC} = 3.0V$;	-0.3		0.57	V
V_{IH_1p8V}	High-level input voltage for SCL/CFG0, SDA/CFG1	$V_{IO} = 1.7V$; $V_{CC} = 3.6V$;	1.19		3.6	V
V_{IL_3p3V}	Low-level input voltage for SCL/CFG0, SDA/CFG1	$V_{IO} = 3.6V$; $V_{CC} = 3.0V$;	-0.3		0.8	V
V_{IL_3p3V}	Low-level input voltage for AC_EN	$V_{IO} = 3.6V$; $V_{CC} = 3.0V$;	-0.3		0.8	V
V_{IH_3p3V}	High-level input voltage for SCL/CFG0, SDA/CFG1	$V_{IO} = 3.0V$; $V_{CC} = 3.6V$;	2.2		3.6	V
V_{IH_3p3V}	High-level input voltage for AC_EN, HPDOUT_SEL	$V_{IO} = 3.0V$; $V_{CC} = 3.6V$;	2.2		3.6	V
V_{OL_1p2V}	Low-level output voltage SDA/CFG1	$V_{CC} = 3.0V$; $V_{IO} = 1.2V$;	-0.3		0.3	V
I_{OL_1p2V}	Low-level output current SDA/CFG1	$V_{CC} = 3.0V$; $V_{IO} = 1.2V$;	2			mA
V_{OL}	Low-level output voltage SDA/CFG1	$V_{CC} = 3.0V$; $V_{IO} = 1.8V$ or $3.3V$;	-0.3		0.4	V
I_{OL}	Low-level output current SDA/CFG1	$V_{CC} = 3.0V$; $V_{IO} = 1.8V$ or $3.3V$;	4			mA
I_{IL_I2C}	Low-level input current SCL/CFG0, SDA/CFG1	$V_{IN} = 0V$; $V_{IO} = 1.8V$ or $3.3V$;	-1		1	μA
I_{LEAK}	Fail-safe input current for SCL/CFG0, SDA/CFG1	$V_{IN} = 3.6V$; $V_{CC} = 0V$;	-25		25	μA
V_{IL_EN}	Low-level input voltage for EN pin.	$V_{IO} = 1.14V$; $V_{CC} = 3.3V$;	-0.3		0.4	V
V_{IH_EN}	High-level input voltage for EN pin.	$V_{IO} = 3.6V$; $V_{CC} = 3.3V$;	0.8		3.6	V
I_{IL}	Low-level input current EN	$V_{IN} = 0V$; $V_{IO} = 1.8V$ or $3.3V$; $V_{CC} = 3.6V$	-20		20	μA
I_{IL}	Low-level input current AC_EN	$V_{IN} = 0V$; $V_{IO} = 1.8V$ or $3.3V$;	-1		1	μA
I_{IH_EN}	High-level input current for EN	$V_{IN} = 3.6V$; $V_{IO} = 1.8V$ or $3.3V$;	-1		1	μA
I_{IH_ACEN}	High-level input current for AC_EN	$V_{IN} = 3.6V$; $V_{IO} = 1.8V$ or $3.3V$;	-24		24	μA
$I_{IH_HPDOUTSEL}$	High-level input current for HPDOUT_SEL	$V_{IN} = 3.6V$; $V_{IO} = 1.8V$ or $3.3V$;	-24		30	μA
R_{PU_EN}	Internal Pull-up resistance on EN.		125	250	350	$k\Omega$
R_{PD_ACEN}	Internal Pull-down resistance on AC_EN		125	250	350	$k\Omega$
$R_{PD_HPDOUTSEL}$	Internal Pull-down resistance on HPDOUT_SEL		125	250	350	$k\Omega$
C_{I2C_PINS}	Capacitance for SCL/CFG0 and SDA/CFG1	$f = 100\text{ kHz}$;			5	pF
$C_{(I2C_FM+_BUS)}$	I2C bus capacitance for FM+ (1MHz)				150	pF
$C_{(I2C_FM_BUS)}$	I2C bus capacitance for FM (400kHz)				150	pF
$R_{(EXT_I2C_FM+)}$	External resistors on both SDA and SCL when operating at FM+ (1MHz)	$C_{(I2C_FM+_BUS)} = 150\text{ pF}$	620	820	910	Ω
$R_{(EXT_I2C_FM)}$	External resistors on both SDA and SCL when operating at FM (400kHz)	$C_{(I2C_FM_BUS)} = 150\text{ pF}$	620	1500	2200	Ω
LV_DDC_SDA and LV_DDC_SCL						
V_{IL_1p2V}	Low-level input voltage	$V_{CC} = 3.0V$;	-0.3		0.378	V
V_{IH_1p2V}	High-level input voltage	$V_{CC} = 3.6V$;	0.8		3.6	V
V_{IL_1p8V}	Low-level input voltage	$V_{CC} = 3.0V$;	-0.3		0.57	V
V_{IH_1p8V}	High-level input voltage	$V_{CC} = 3.6V$;	1.19		3.6	V
V_{IL_3p3V}	Low-level input voltage	$V_{CC} = 3.0V$;	-0.3		0.8	V
V_{IH_3p3V}	High-level input voltage	$V_{CC} = 3.6V$;	2.2		3.6	V

6.5 Electrical Characteristics (continued)

over recommended voltage and operating free-air temperature range (unless otherwise noted)

PARAMETER		TEST CONDITIONS	MIN	TYP	MAX	UNIT
DDC Buffer (LV_DDC_SCL, LV_DDC_SDA, HV_DDC_SCL, HV_DDC_SDA)						
V _{HV_IH}	High-level input voltage for HV_DDC_SCL and HV_DDC_SDA	VIO = 3.3V; VCC = 3.0V	3.3		5.3	V
V _{HV_IL}	Low-level input voltage for HV_DDC_SCL and HV_DDC_SDA	VIO = 3.3V; VCC = 3.0V	-0.3		1.6	V
V _{LV_IH}	High-level input voltage for LV_DDC_SCL and LV_DDC_SDA for 1.2-V LVCMOS	VIO = 1.14V; VCC = 3.3V	0.8		3.6	V
V _{LV_IH}	High-level input voltage for LV_DDC_SCL and LV_DDC_SDA for 1.8-V LVCMOS	VIO = 1.7V; VCC = 3.3V	1.15		3.6	V
V _{LV_IH}	High-level input voltage for LV_DDC_SCL and LV_DDC_SDA for 3.3-V LVCMOS	VIO = 3.0V; VCC = 3.3V	2.1		3.6	V
V _{LV_IL}	Low-level input voltage for LV_DDC_SCL and LV_DDC_SDA for 1.2-V LVCMOS	VIO = 1.26V; VCC = 3.3V	-0.3	0.082 *	VIO	V
V _{LV_IL}	Low-level input voltage for LV_DDC_SCL and LV_DDC_SDA for 1.8-V LVCMOS	VIO = 1.9V; VCC = 3.3V	-0.3	0.10 *	VIO	V
V _{LV_IL}	Low-level input voltage for LV_DDC_SCL and LV_DDC_SDA for 3.3-V LVCMOS	VIO = 3.6V; VCC = 3.3V	-0.3	0.10 *	VIO	V
I _{LV_IL_FS}	Failsafe Input leakage for LV_DDC_SCL and LV_DDC_SDA	VCC = 0-V; VIO = V _{IN} = 2.0-V	-5.5		5.5	μA
I _{HV_IL_FS}	Failsafe Input leakage for HV_DDC_SCL and HV_DDC_SDA	V _{IN} = 5.3V through 1.5-kΩ; VCC = 0-V; VIO = 0-V;	-5		5	μA
I _{HV_IL}	Input leakage for HV_DDC_SCL and HV_DDC_SDA	HV V _{IN} = 5.3V; LV V _{IN} = VIO;	-5		5	μA
I _{LV_IL}	Input leakage for LV_DDC_SCL and LV_DDC_SDA	HV V _{IN} = 5.3V; LV V _{IN} = VIO;	-5.5		5.5	μA
I _{HV_OL}	Low-level output current	V _{HV_OL} = 0.4V; HDMI5V = 5.3V; Pullup with 1.4-kΩ; VCC = 3.0V;	3.5			mA
V _{HV_OL}	Low-level output voltage for HV_DDC_SCL and HV_DDC_SDA	HDMI5V = 5.3V; Pullup with 1.4-kΩ; VCC = 3.0V;			0.4	V
V _{LV_OL}	Low-level output voltage for LV_DDC_SCL and LV_DDC_SDA for 1.2-V LVCMOS	VCC = 3.0V; VIO = 1.26V	0.2		0.3	V
V _{LV_OL}	Low-level output voltage for LV_DDC_SCL and LV_DDC_SDA for 1.8-V LVCMOS	VCC = 3.0V; VIO = 1.9V	0.3		0.4	V
V _{LV_OL}	Low-level output voltage for LV_DDC_SCL and LV_DDC_SDA for 3.3-V LVCMOS	VCC = 3.0V; VIO = 3.6V	0.6		0.75	V
Δ V _{LV_HYST_1p2V}	Hysteresis on LV side for 1.2V LVCMOS	VIO = 1.2V; VCC = 3.3V;		20		mV
Δ V _{LV_HYST_1p8V}	Hysteresis on LV side for 1.8V LVCMOS	VIO = 1.8V; VCC = 3.3V;		20		mV
Δ V _{LV_HYST_3p3V}	Hysteresis on LV side for 3.3V LVCMOS	VIO = 3.3V; VCC = 3.3V		50		mV
Δ V _{HV_HYST}	Hysteresis on HV side	VIO = 3.3V; VCC = 3.3V; HDMI5V = 4.8V or 5.3V;		500		mV
R _{PULV}	Internal pull-up resistor to VIO		7450	10000	13000	Ω
R _{PUHV}	External pull-up resistor to HDMI 5V		1500	1800	2000	Ω
C _{IOHV}	Capacitance for HV_DDC_SCL and HV_DDC_SDA				12	pF

6.5 Electrical Characteristics (continued)

over recommended voltage and operating free-air temperature range (unless otherwise noted)

PARAMETER		TEST CONDITIONS	MIN	TYP	MAX	UNIT
C_{IOLV}	Capacitance for LV_DDC_SCL and LV_DDC_SDA				7	pF
V_{HDMI5V}	HDMI 5V		4.8		5.3	V
C_{HV_BUS}	Bus capacitance for HV_DDC_SCL and HV_DDC_SDA				750	pF
C_{LV_BUS}	Bus capacitance for LV_DDC_SCL and LV_DDC_SDA				50	pF
HPD_IN						
$V_{IL-HPDIN}$	Low-level input voltage for HPD_IN	$V_{CC} = 3.6V$;	-0.3		0.8	V
$V_{IH-HPDIN}$	High-level input voltage for HPD_IN	$V_{CC} = 3.6V$	2.0		5.5	V
$I_{H-HPDIN}$	High-level input current for HPD_IN	Device powered; $V_{IH} = 5.5V$; Includes internal pull-down resistor	-50		50	μA
$I_{L-HPDIN}$	Low-level input current for HPD_IN	Device powered; $V_{IL} = 0V$; Includes internal pull-down resistor	-1		1	μA
$R_{PD-HPDIN}$	Internal Pull-down resistance on HPD_IN	$V_{CC} = 3.3V$; HPD_IN = 5.5V	110	150	210	k Ω
$I_{LEAK-HPDIN}$	Fail-safe condition leakage current for HPD_IN	$V_{CC} = 0V$; HPD_IN = 5.5V;	-50		50	μA
HPD_OUT						
V_{OH_3p3V}	High level output voltage when configured for 3.3V LVCMOS push/pull.	$V_{CC} = 3.0V$;	2.4		3.465	V
V_{OH_1p8V}	High level output voltage when configured for 1.8V LVCMOS push/pull.	$V_{CC} = 3.0V$;	1.3		1.95	V
V_{OL_PP}	Low level output voltage when configured for push/pull.	$V_{CC} = 3.0V$;	-0.3		0.4	V
V_{OL_OD}	Low level output voltage when configured for open drain.	$V_{CC} = 3.0V$; 0.5k to 3.6V load;	-0.3		0.4	V
I_{OH_3p3V}	High level output current for 3.3-V LVCMOS	HPD_IN = $V_{IH-HPDIN}$;			-4	mA
I_{OL_3p3V}	Low level output current for 3.3-V LVCMOS	HPD_IN = $V_{IL-HPDIN}$; I2C mode;	4			mA
I_{OH_1p8V}	High level output current for 1.8-V LVCMOS	HPD_IN = $V_{IH-HPDIN}$;			-1.1	mA
I_{OL_1p8V}	Low level output current for 1.8-V LVCMOS	HPD_IN = $V_{IL-HPDIN}$; I2C mode;	1.2			mA
4-LEVEL CONTROL (MODE, LINEAR_EN, EQ1, ADDR/EQ0, TXSLEW, TXPRE, TXSWG)						
V_{TH}	Threshold "0" / "R"	$V_{CC} = 3.3V$		0.55		V
V_{TH}	Threshold "R" / "F"	$V_{CC} = 3.3V$		1.65		V
V_{TH}	Threshold "F" / "1"	$V_{CC} = 3.3V$		2.7		V
I_{IH}	High-level input current	$V_{IH} = 3.6V$; $V_{CC} = 3.6V$;	20		60	μA
I_{IL}	Low-level input current	$V_{IL} = 0V$; $V_{CC} = 3.6V$;	-100		-40	μA
R_{4PU}	Internal pullup resistance			48		k Ω
R_{4PD}	Internal pull-down resistance			98		k Ω
HDMI HIGH SPEED INPUTS						
$D_{R_RX_DATA}$	Data lanes data rate		0.25		6	Gbps
$D_{R_RX_CLK}$	Clock lane data rate		0.25		6	Gbps
$V_{ID(DC)}$	DC differential input swing	At pins; LINEAR_EN = L;	400		1200	mVpp

6.5 Electrical Characteristics (continued)

over recommended voltage and operating free-air temperature range (unless otherwise noted)

PARAMETER		TEST CONDITIONS	MIN	TYP	MAX	UNIT
V _{ID(EYE)}	Differential input swing eye opening	At pins;	75			mVpp
V _{RX_ASSE} RT	Signal detect assert level.	PRBS7 pattern; 6 Gbps;		150		mVpp
V _{RX_DEAS} SERT	Signal detect deassert level.	PRBS7 pattern; 6 Gbps;		95		mVpp
V _{ICM-DC}	Input DC common mode voltage bias	At pins;	2.5	3.3	VCC	V
E _{EQ_6Gbps} _MAX_LT	Maximum Fixed EQ gain (AC - DC)	At 3 GHz; 6Gbps CTLE; EQ15; DC Gain = 0dB; Limited Mode; At output of RX;		12.0		dB
E _{EQ_6Gbps} _s_MIN_LT	Minimum Fixed EQ gain (AC - DC)	At 3 GHz; 6Gbps CTLE; EQ0; DC Gain = 0dB; Limited Mode; At output of RX;		0.6		dB
E _{EQ_6Gbps} _s_BYPASS_ LT	Maximum Fixed EQ Gain when EQ is bypassed. (AC - DC)	At 3GHz; 6Gbps CTLE; DC Gain = 0dB; Limited Mode; At output of RX;		-2.0		dB
E _{EQ_3Gbps} _MAX_LT	Maximum Fixed EQ gain (AC - DC)	At 1.5 GHz; 3Gbps CTLE; EQ15; DC Gain = 0dB; Limited Mode; At output of RX;		12		dB
E _{EQ_3Gbps} _s_MIN_LT	Minimum Fixed EQ gain (AC - DC)	At 1.5 GHz; 3Gbps CTLE; EQ0; DC Gain = 0dB; Limited Mode; At output of RX;		0.8		dB
R _{INT}	Input differential impedance when termination is enabled	At TTP2; HPD_IN = H;	85	100	115	Ω
HDMI HIGH SPEED OUTPUTS (Limited Mode)						
V _{OL_open}	Single-ended low-level output voltage for DR ≤ 1.65 Gbps data rate	DR = 270 Mbps; HPD_IN = H; AC_EN = L (DC-coupled); TXSWG = "F" (1000mV); TXPRE = "F" (0dB); TX termination open; VCC_EXT = 3.3V; 25°C ≤ Ta ≤ 85°C;	2.7		2.9	V
V _{OL_300}	Single-ended low-level output voltage 1.65 Gbps < DR ≤ 3.4 Gbps.	DR = 3.4 Gbps; HPD_IN = H; AC_EN = L (DC-coupled); TXSWG = "F" (1000mV); TXPRE = "F" (0dB); TX termination 300-ohms; VCC_EXT = 3.3V; 25°C ≤ Ta ≤ 85°C;	2.6		2.9	V
V _{OL_DAT2} 0	Data lane single-ended low-level output voltage 3.4 Gbps < DR ≤ 6 Gbps.	DR = 5.94 Gbps; HPD_IN = H; AC_EN = L (DC-coupled); TXSWG = "F" (1000mV); TXPRE = "F" (0dB); VCC_EXT = 3.3V; 25°C ≤ Ta ≤ 85°C;	2.3		2.9	V
V _{SWING_D} A_14	Single-ended output voltage swing on data lanes with TX term set to open.	DR = 1.5 Gbps; HPD_IN = H; AC_EN = L (DC-coupled); TXSWG = "F" (1000mV); TXPRE = "F" (0dB); VCC_EXT = 3.3V; 25°C ≤ Ta ≤ 85°C;	400	500	600	mV
V _{SWING_D} A_14	Single-ended output voltage swing on data lanes with TX term set to 300-ohms.	DR = 3.4 Gbps; HPD_IN = H; AC_EN = L (DC-coupled); TXSWG = "F" (1000mV); TXPRE = "F" (0dB); VCC_EXT = 3.3V; 25°C ≤ Ta ≤ 85°C;	400	500	600	mV
V _{SWING_D} A_20	Single-ended output voltage swing on data lanes for HDMI2.0 operation.	DR = 5.94 Gbps; HPD_IN = H; AC_EN = L (DC-coupled); TXSWG = "F" (1000mV); TXPRE = "F" (0dB); VCC_EXT = 3.3V; 25°C ≤ Ta ≤ 85°C;	400	500	600	mV
V _{SWING_C} LK_14_OPE N	Single-ended output voltage swing on clock lane for DR ≤ 3.4 Gbps data rate	HPD_IN = H; AC_EN = L (DC-coupled); TXSWG = "F" (1000mV); TXPRE = "F" (0dB); VCC_EXT = 3.3V; 25°C ≤ Ta ≤ 85°C; TERM set to open;	400	500	600	mV
V _{SWING_C} LK_20	Single-ended output voltage swing on clock lane for HDMI 2.0	HPD_IN = H; AC_EN = L (DC-coupled); TXSWG = "F" (1000mV); TXPRE = "F" (0dB); VCC_EXT = 3.3V; 25°C ≤ Ta ≤ 85°C;	300	400	600	mV

6.5 Electrical Characteristics (continued)

over recommended voltage and operating free-air temperature range (unless otherwise noted)

PARAMETER		TEST CONDITIONS	MIN	TYP	MAX	UNIT
V _{OD_3G}	Data lanes Differential output swing	At TTP4; 2.97Gbps; HPD_IN = H; AC_EN = L or H; TXSWG = "F" (1000mV); TXPRE = "F" (0dB); 25°C ≤ Ta ≤ 85°C;	400		1560	mV
V _{OD_6G}	Data lanes Differential output swing	At TTP4_EQ; 5.94Gbps; HPD_IN = H; AC_EN = L or H; TXSWG = "F" (1000mV); TXPRE = "F" (0dB); 25°C ≤ Ta ≤ 85°C;	150		1560	mV
I _{LEAK}	Failsafe condition leakage current	V _{CC} = 0 V; DC-coupled; TMDS output pulled to 3.465 V with 50 ohm resistors			35	μA
I _{OS}	Short circuit current limit	OUT_CLK, OUT_D[2:0] outputs P or N shorted to GND			62	mA
R _{TERM14}	Internal termination for DR ≤ 3.4 Gbps when DC-coupled	TERM = 1h; AC_EN = L (DC-coupled); HPD_IN=H; Active State; 25°C ≤ T _A ≤ 85°C;	235	295	345	Ω
R _{TERM14}	Internal termination for DR ≤ 3.4 Gbps when AC-coupled	TERM = 1h; AC_EN = H (AC-coupled); HPD_IN=H; Active State; 25°C ≤ T _A ≤ 85°C;	235	295	345	Ω
R _{TERM2+}	Internal termination for DR > 3.4 Gbps when DC-coupled.	TERM = 3h; AC_EN = L (DC-coupled); HPD_IN=H; Active State; 25°C ≤ T _A ≤ 85°C;	90	100	110	Ω
R _{TERM2+}	Internal termination for DR > 3.4 Gbps when AC-coupled.	TERM = 3h; AC_EN = H (AC-coupled); HPD_IN=H; Active State; 25°C ≤ T _A ≤ 85°C;	90	100	110	Ω
V _{TXPRE0-RATIO}	Transmitter FFE pre-emphasis ratio for 0dB.	TERM = 3h; HPD_IN = H; TX_AC_EN = 0; CLK_VOD = 3h; D0_TXFFE = 0h; D0_VOD = 3h; D1_TXFFE = 0h; D1_VOD = 3h; D2_TXFFE = 0h; D2_VOD = 3h; 20 * log (Vp/Vn); 128 zeros followed by 128 ones;		0		dB
V _{TXPRE1-RATIO}	Transmitter FFE pre-emphasis ratio for 3.5dB for data lanes	At 5.94Gbps HDMI 2.0; TERM = 3h; HPD_IN = H; TX_AC_EN = 0; CLK_VOD = 3h; D0_TXFFE = 1h; D0_VOD = 3h; D1_TXFFE = 1h; D1_VOD = 3h; D2_TXFFE = 1h; D2_VOD = 3h; 20 * log (Vp/Vn); 128 zeros followed by 128 ones;		4.0		dB
V _{TXPRE2-RATIO}	Transmitter FFE pre-emphasis ratio for 6dB for data lanes	At 5.94Gbps HDMI 2.0; TERM = 3h; HPD_IN = H; TX_AC_EN = 0; CLK_VOD = 3h; D0_TXFFE = 2h; D0_VOD = 3h; D1_TXFFE = 2h; D1_VOD = 3h; D2_TXFFE = 2h; D2_VOD = 3h; 20 * log (Vp/Vn); 128 zeros followed by 128 ones;		6.5		dB

6.6 Timing Requirements

		MIN	NOM	MAX	UNIT
Local I2C (SCL/CFG0, SDA/CFG1). Refer to 图 7-9.					
f _{SCL}	I ² C clock frequency			1	MHz
t _{BUF}	Bus free time between START and STOP conditions	0.5			μs
t _{HD_STA}	Hold time after repeated START condition. After this period, the first clock pulse is generated	0.26			μs
t _{LOW}	Low period of the I ² C clock	0.5			μs
t _{HIGH}	High period of the I ² C clock	0.26			μs
t _{SU_STA}	Setup time for a repeated START condition	0.26			μs
t _{HD_DAT}	Data hold time	0			μs

6.6 Timing Requirements (continued)

		MIN	NOM	MAX	UNIT
t _{SU_DAT}	Data setup time	50			ns
t _R	Rise time of both SDA and SCL signals			120	ns
t _F	Fall time of both SDA and SCL signals	4		120	ns
t _{SU_STO}	Setup time for STOP condition	0.26			μs
DDC Snoop I2C Timings. Refer to 图 7-9.					
f _{SCL}	I ² C DDC clock frequency			100	kHz
t _{BUF}	Bus free time between START and STOP conditions	4.7			μs
t _{HD_STA}	Hold time after repeated START condition. After this period, the first clock pulse is generated	4			μs
t _{LOW}	Low period of the I ² C clock	4.7			μs
t _{HIGH}	High period of the I ² C clock	4			μs
t _{SU_STA}	Setup time for a repeated START condition	4.7			μs
t _{HD_DAT}	Data hold time	0			μs
t _{SUDAT}	Data setup time	250			ns
t _R	Rise time of both SDA and SCL signals. Measured from 30% to 70%.			1000	ns
t _F	Fall time of both SDA and SCL signals Measured from 70% to 30%.			300	ns
t _{SU_STO}	Setup time for STOP condition	4			μs
C _{b_LV}	Capacitive load for each bus line on LV side			50	pF
Power-On. Refer to 图 7-1.					
t _{VCC_RAMP}	V _{CC} supply ramp. Measured from 10% to 90%.	0.10		50	ms
t _{D_PG}	Internal POR de-assertion delay			5	ms
t _{VIO_SU}	V _{IO} supply stable before reset ⁽²⁾ high.	100			μs
t _{CFG_SU}	Configuration pins ⁽¹⁾ setup before reset ⁽²⁾ high.	0			μs
t _{CFG_HD}	Configuration pins ⁽¹⁾ hold after reset ⁽²⁾ high.	500			μs

- (1) Follow comprise the configuration pins: MODE, ADDR/EQ0, EQ1, TXSWG, TXSLEW, TXPRE, AC_EN, HPDOUT_SEL, DCGAIN
(2) Reset is the logical AND of internal POR and EN pin.

6.7 Switching Characteristics

over recommended voltage and operating free-air temperature range (unless otherwise noted)

PARAMETER		TEST CONDITIONS	MIN	TYP	MAX	UNIT
Redriver						
f _{HDMI14_o pen}	Maximum HDMI 1.4 clock frequency at which TX termination is guaranteed to be open	HDMI1.4; 25MHz ≤ IN_CLK ≤ 340MHz; TXTERM_AUTO_HDMI14 = 0h; TERM = 2h; TX is DC-coupled;	165			MHz
f _{HDMI14_300}	Minimum HDMI 1.4 clock frequency at which TX termination is guaranteed to be 300-ohms	HDMI1.4; 25MHz ≤ IN_CLK ≤ 340MHz; TXTERM_AUTO_HDMI14 = 0h; TERM = 2h; TX is DC-coupled;			250	MHz
t _{PD}	Propagation delay time	At TTP4;	90		220	ps
t _{SK1(T)}	Clock lane Intra-pair output skew with zero intra-pair skew at inputs	At TTP4; No intra-pair skew at input; 6Gbps with 150 MHz clock; TX termination 100-Ω; Limited mode;		0.10	0.15	UI
t _{SK1(T)}	Data lane Intra-pair output skew with zero intra-pair skew at inputs	At TTP4; No intra-pair skew at input; At 6Gbps; TX termination 100-Ω; Limited mode;		0.035	0.09	UI
t _{SK2(T)}	Inter-pair output skew	At TTP4; At 6Gbps;			30	ps
t _{RF-CLK-14}	Transition time (rise and fall time) for clock lane when operating at HDMI1.4	At TTP4; 20% to 80%; Clock Frequency = 300 MHz;	75		600	ps

6.7 Switching Characteristics (continued)

over recommended voltage and operating free-air temperature range (unless otherwise noted)

PARAMETER		TEST CONDITIONS	MIN	TYP	MAX	UNIT
$t_{RF-CLK-20}$	Transition time (rise and fall time) for clock lane when operating at HDMI 2.0	At TTP4; 20% to 80%; Clock Frequency = 150 MHz;	75		600	ps
t_{RF_14}	Transition time (rise and fall time) for data lanes when operating at HDMI 1.4	At TTP4; 20% to 80%; DR = 3 Gbps; SLEW_HDMI14 = default; PRBS7 pattern; Clock Frequency = 300 MHz;	75		195	ps
t_{RFDAT_20}	Transition time (rise and fall time) for data lanes when operating at HDMI 2.0	At TTP4; 20% to 80%; DR = 6 Gbps; SLEW_HDMI20 = default; PRBS7 pattern; Clock Frequency = 150 MHz;	42.5		115	ps
t_{TRANS_3G}	Transition bit duration when de-emphasis/pre-emphasis is enabled	At TTP4; DR = 3Gbps; Clock pattern of 128 zeros followed by 128 ones;	0.4		1	UI
t_{TRANS_6G}	Transition bit duration when de-emphasis/pre-emphasis is enabled	At TTP4; DR = 6Gbps; Clock pattern of 128 zeros followed by 128 ones;	0.4		1	UI
HPD						
t_{HPD_PD}	HPD_IN to HPD_OUT propagation delay	Refer to 图 7-7			100	μ s
$t_{HPD_PWR\ DOWN}$	HPD_IN debounce time before declaring Powerdown. Enter Powerdown if HPD_IN is low after debounce time.	Refer to 图 7-7	2		4	ms
$t_{HPD_STANDBY}$	HPD_IN debounce time required for exiting Powerdown to Standby. Exit Powerdown if HPD_IN is high after debounce time.	Refer to 图 7-8	2		4	ms
Standby						
$t_{STANDBY_ENTRY}$	Detection of electrical idle to entry into Standby.	HPD_IN = H;			300	μ s
t_{SIGDET_DB}	Maximum differential signal glitch time rejected during debounce before transitioning from standby to active	HPD_IN = H;			25	μ s
t_{SIGDET_DB}	Maximum differential signal glitch time rejected during debounce before transitioning from active to standby	HPD_IN = H;			50	ns
$t_{STANDBY_EXIT}$	Detection of differential signal to exit from Standby to Active state	HPD_IN = H;			200	μ s
f_{SCL}	DDC buffer frequency				100	kHz
t_{PLH1}	Propagation delay time. Low-to-high-level output. VIO set to 1.2V LVCMOS levels.	LV to HV; $C_{LV_BUS} = C_{HV_BUS} = 50pF$; DDC_LV_DCC_EN = 1'b1;			1400	ns
	Propagation delay time. Low-to-high-level output. VIO set to 1.8V LVCMOS levels.	LV to HV; $C_{LV_BUS} = C_{HV_BUS} = 50pF$; DDC_LV_DCC_EN = 1'b1;			1400	ns
	Propagation delay time. Low-to-high-level output. VIO set to 3.3V LVCMOS levels.	LV to HV; $C_{LV_BUS} = C_{HV_BUS} = 50pF$; DDC_LV_DCC_EN = 1'b1;			1400	ns
t_{PLH2}	Propagation delay time. Low-to-high-level output. VIO set to 1.2V LVCMOS levels.	HV to LV; $C_{LV_BUS} = C_{HV_BUS} = 50pF$; DDC_LV_DCC_EN = 1'b1;			410	ns
	Propagation delay time. Low-to-high-level output. VIO set to 1.8V LVCMOS levels.	HV to LV; $C_{LV_BUS} = C_{HV_BUS} = 50pF$; DDC_LV_DCC_EN = 1'b1;			410	ns
	Propagation delay time. Low-to-high-level output. VIO set to 3.3V LVCMOS levels.	HV to LV; $C_{LV_BUS} = C_{HV_BUS} = 50pF$; DDC_LV_DCC_EN = 1'b1;			410	ns
t_{PHL1}	Propagation delay time. High to low-level output. VIO set to 1.2V LVCMOS.	LV to HV; $C_{LV_BUS} = C_{HV_BUS} = 50pF$; DDC_LV_DCC_EN = 1'b1;			1200	ns
	Propagation delay time. High to low-level output. VIO set to 1.8V LVCMOS.	LV to HV; $C_{LV_BUS} = C_{HV_BUS} = 50pF$; DDC_LV_DCC_EN = 1'b1;			1200	ns
	Propagation delay time. High to low-level output. VIO set to 3.3V LVCMOS.	LV to HV; $C_{LV_BUS} = C_{HV_BUS} = 50pF$; DDC_LV_DCC_EN = 1'b1;			1200	ns

6.7 Switching Characteristics (continued)

over recommended voltage and operating free-air temperature range (unless otherwise noted)

PARAMETER		TEST CONDITIONS	MIN	TYP	MAX	UNIT
t _{PHL2}	Propagation delay time. High to low-level output. VIO set to 1.2V LVCMOS.	HV to LV; C _{LV_BUS} = C _{HV_BUS} = 50pF; DDC_LV_DCC_EN = 1'b1;			535	ns
	Propagation delay time. High to low-level output. VIO set to 1.8V LVCMOS.	HV to LV; C _{LV_BUS} = C _{HV_BUS} = 50pF; DDC_LV_DCC_EN = 1'b1;			535	ns
	Propagation delay time. High to low-level output. VIO set to 3.3V LVCMOS.	HV to LV; C _{LV_BUS} = C _{HV_BUS} = 50pF; DDC_LV_DCC_EN = 1'b1;			535	ns
t _{LV_FALL}	LV side fall time for 1.2-V LVCMOS	70% to 30%; C _{LV_BUS} = C _{HV_BUS} = 50pF;	75		260	ns
	LV side fall time for 1.8-V LVCMOS	70% to 30%; C _{LV_BUS} = C _{HV_BUS} = 50pF;	75		260	ns
	LV side fall time for 3.3-V LVCMOS	70% to 30%; C _{LV_BUS} = C _{HV_BUS} = 50pF;	75		260	ns
t _{HV_FALL}	HV side fall time	70% to 30%; C _{LV_BUS} = C _{HV_BUS} = 50pF;	75		260	ns
t _{LV_RISE}	LV side rise time for 1.2-V LVCMOS	30% to 70%; C _{LV_BUS} = C _{HV_BUS} = 50pF; Pulled up to VIO using R _{PULV} ;	300		670	ns
	LV side rise time for 1.8-V LVCMOS	30% to 70%; C _{LV_BUS} = C _{HV_BUS} = 50pF; Pulled up to VIO using R _{PULV} ;	300		670	ns
	LV side rise time for 3.3-V LVCMOS	30% to 70%; C _{LV_BUS} = C _{HV_BUS} = 50pF; Pulled up to VIO using R _{PULV} ;	300		670	ns
t _{HV_RISE_50pF}	HV side rise time (50pF load)	30% to 70%; C _{LV_BUS} = C _{HV_BUS} = 50pF; VCC = 3.0V; HDMI5V = 5.3V; Pulled up to HDMI5V using R _{PUHV} ;			225	ns
t _{HV_RISE_750pF}	HV side rise time (750pF load)	30% to 70%; C _{LV_BUS} = 50pF; C _{HV_BUS} = 750pF; VCC = 3.0V; HDMI5V = 5.3V; Pulled up to HDMI5V using R _{PUHV} ;			1250	ns

6.8 Typical Characteristics



图 6-1. 3Gbps CTLE EQ Curves with GLOBAL_DCG = 0x2 in Limited Mode



图 6-2. 6Gbps CTLE EQ Curves with GLOBAL_DCG = 0x2 in Limited Mode

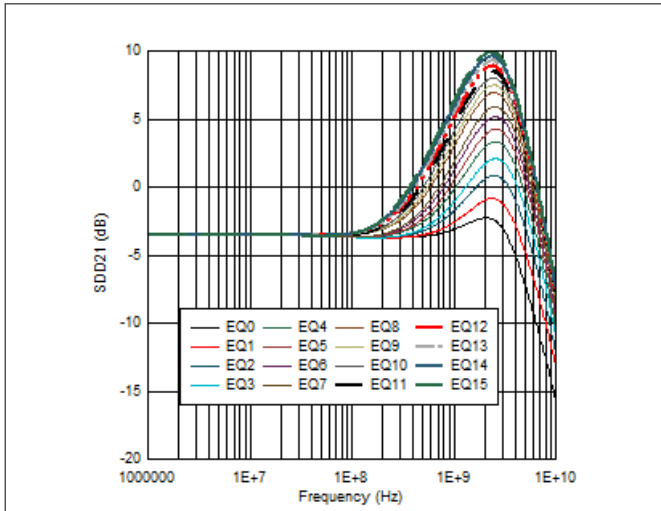

图 6-3. Input Differential Return Loss (SDD11)

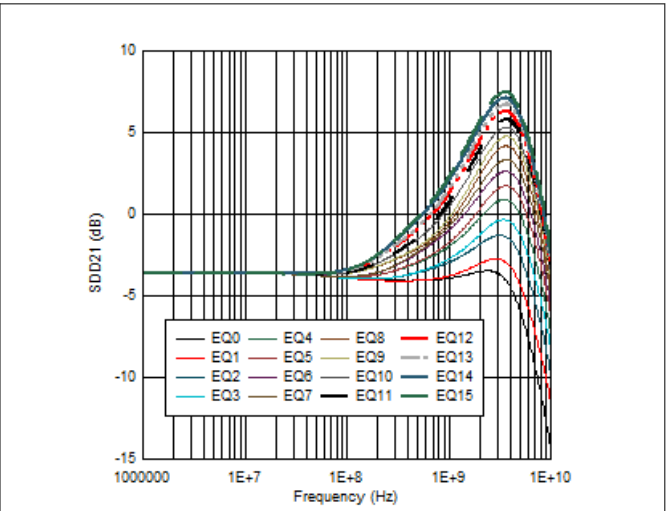

图 6-4. Output Differential Return Loss (SDD22)

7 Parameter Measurement Information

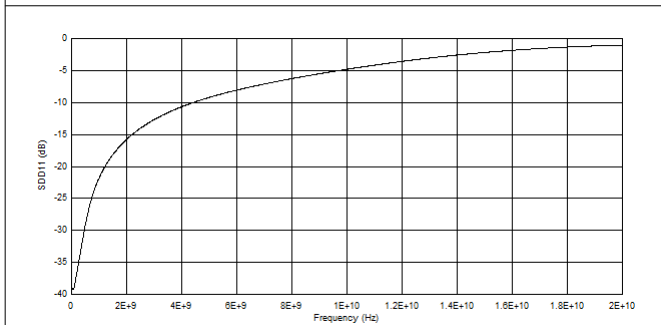

图 7-1. Power-On Timing Requirements

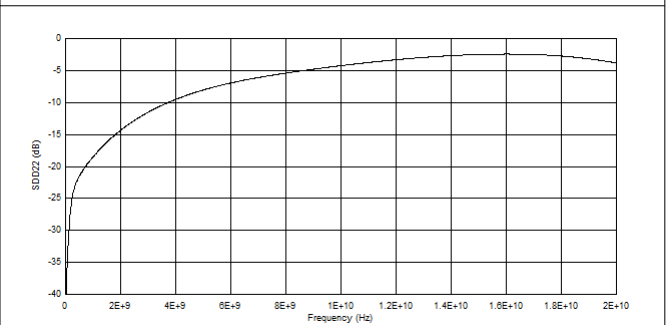

图 7-2. TMD5 Main Link Test Circuit

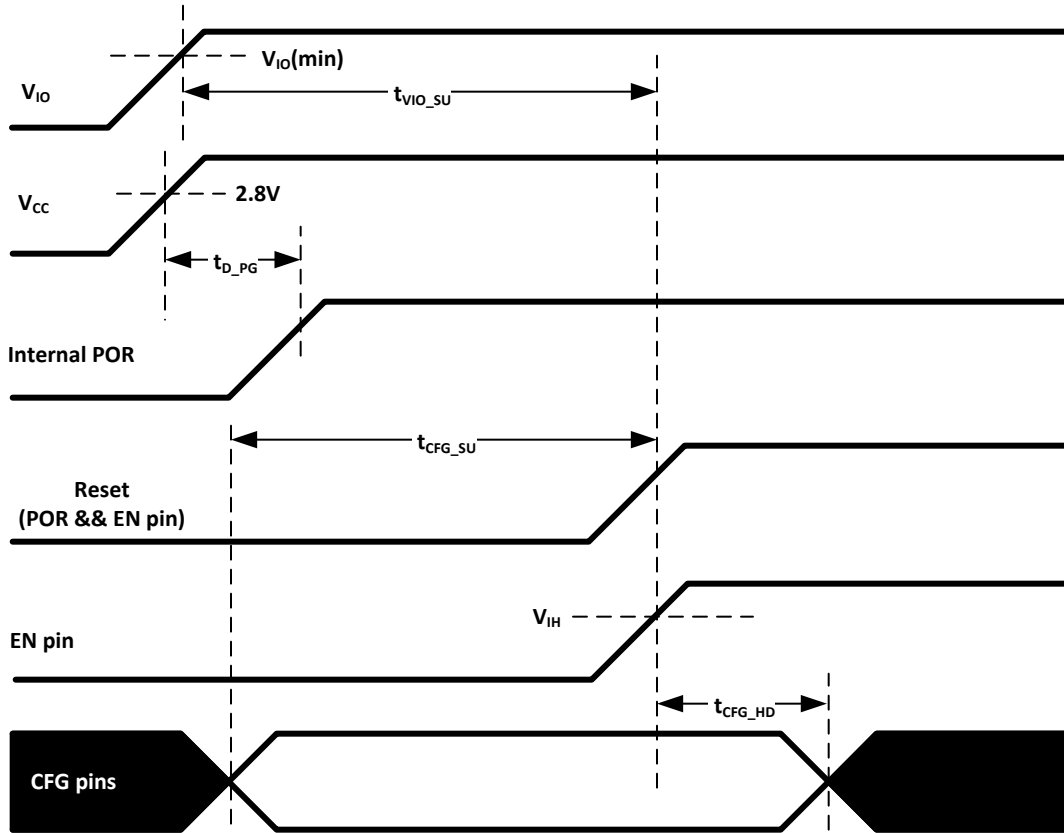

图 7-3. Input or Output Timing Measurements

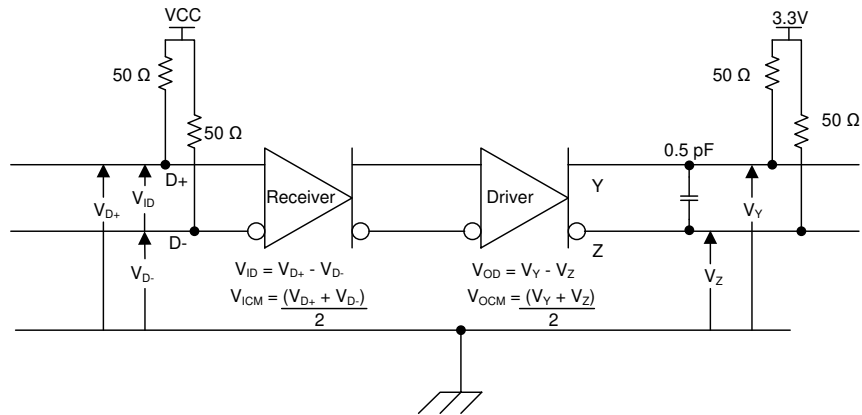

图 7-4. Output Differential Waveform

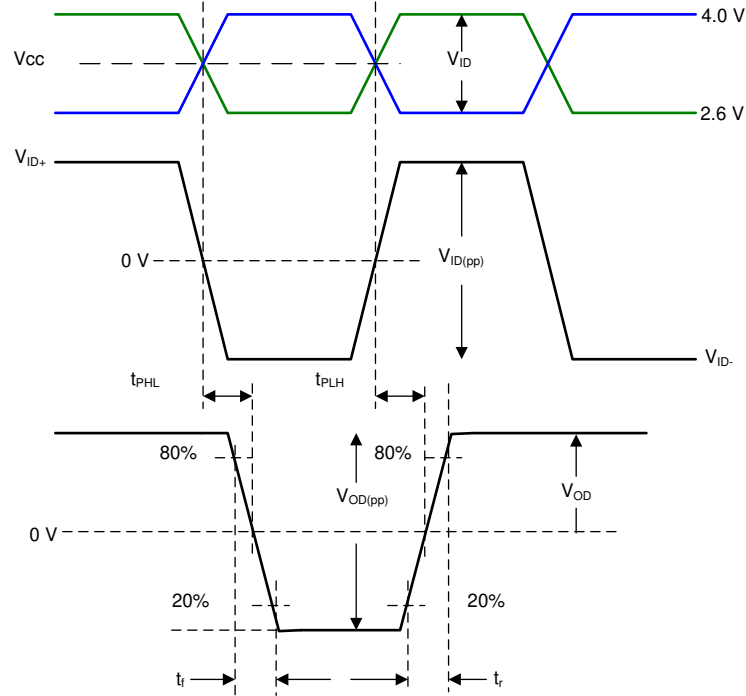

图 7-5. Output Differential Waveform with De-Emphasis

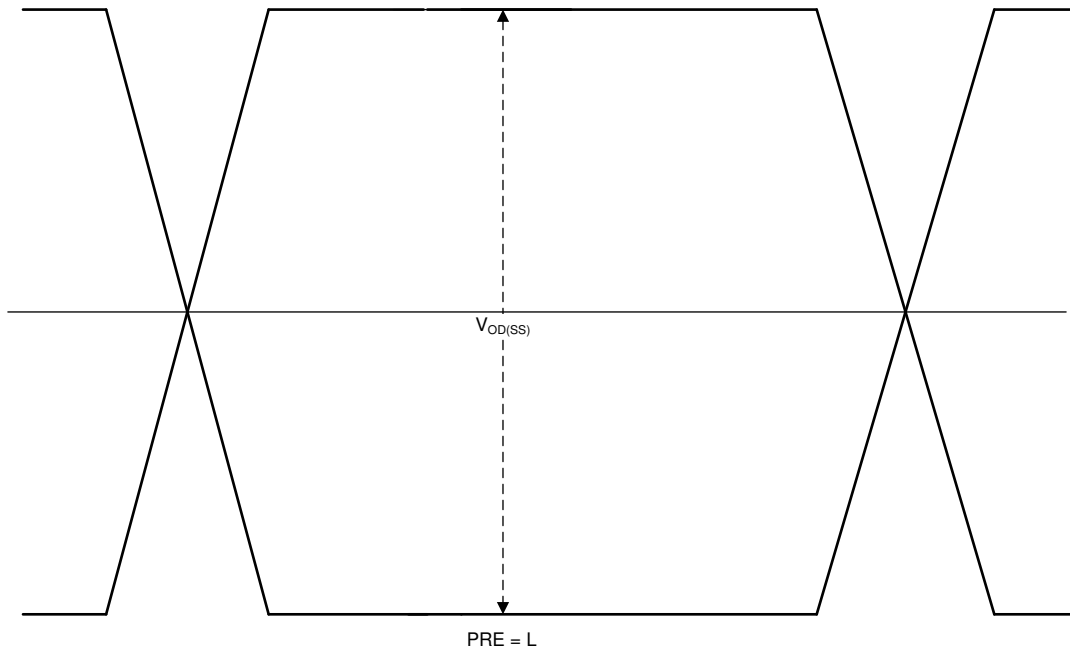

Copyright © 2016, Texas Instruments Incorporated

- (1) The FR4 trace between TTP1 and TTP2 is designed to emulate 1-12" of FR4, ac-coupling cap, connector and another 2" of FR4. Trace width - 4 mils. 100 Ω differential impedance.
- (2) All Jitter is measured at a BER of 10^9 .
- (3) Residual jitter reflects the total jitter measured at TTP4 minus the jitter measured at TTP
- (4) AVCC = 3.3 V.
- (5) $R_T = 50 \Omega$.
- (6) For HDMI 1.4 or 2.0, the input signal from parallel Bert does not have any pre-emphasis or de-emphasis. Refer to *Recommended Operating Conditions*.

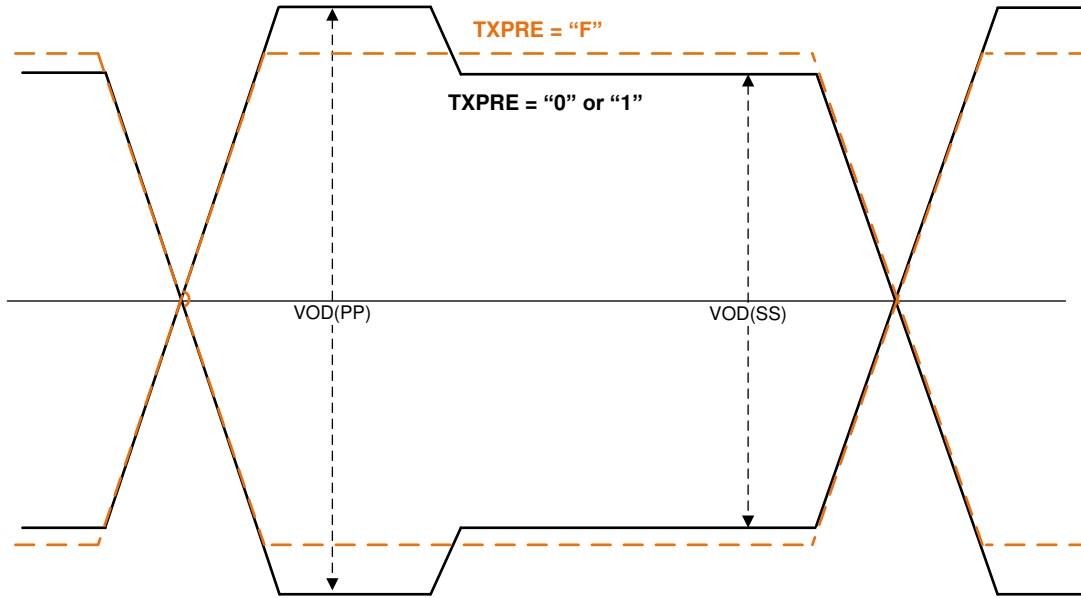
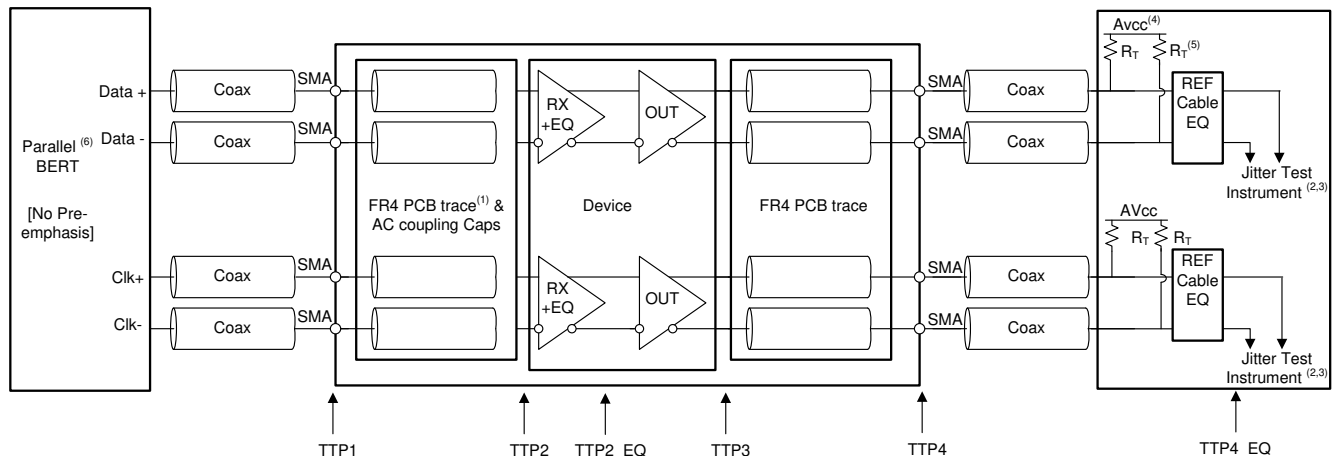
图 7-6. HDMI Output Jitter Measurement



图 7-7. HPD Logic Shutdown and Propagation Timing



图 7-8. HPD Logic Standby and Propagation Timing

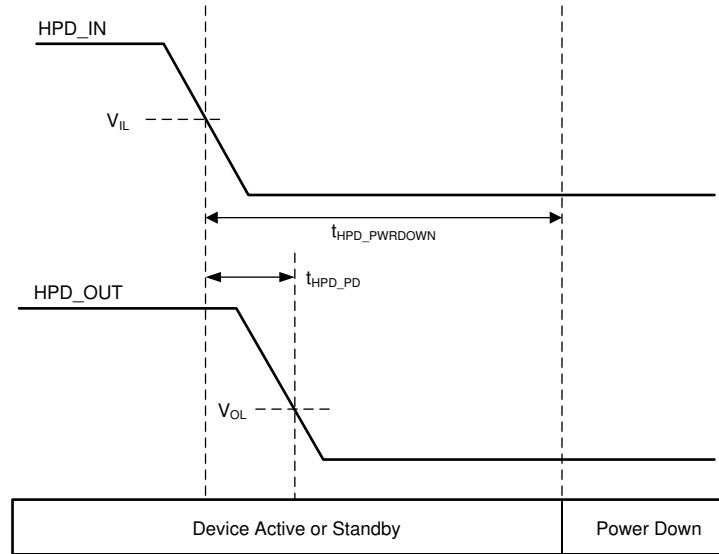

图 7-9. I²C SCL and SDA Timing

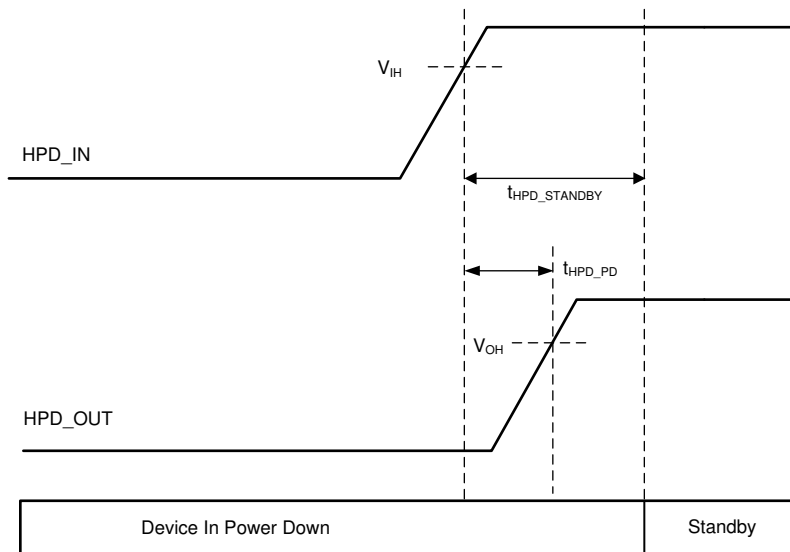

图 7-10. $V_{ID(DC)}$ and $V_{ID(EYE)}$

8 Detailed Description

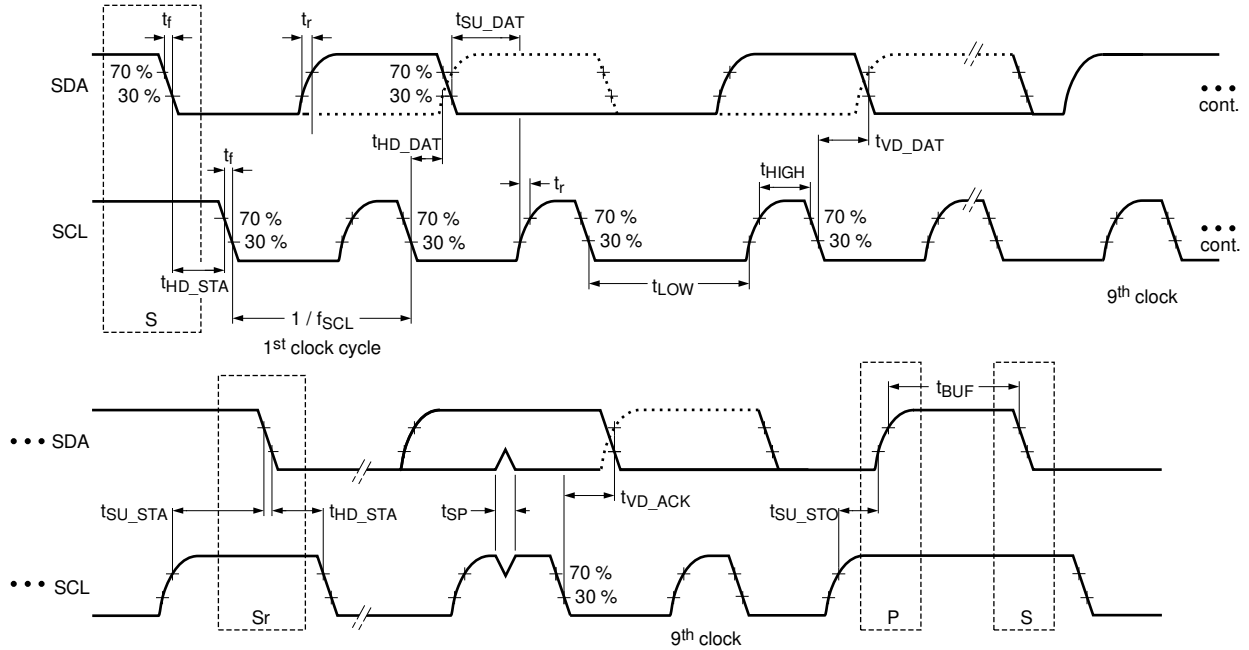
8.1 Overview

The TDP0604 is a HDMI 2.0 redriver supporting data rates up to 6 Gbps. It is also backwards compatible to HDMI 1.4b. The high-speed differential inputs and outputs can be either AC-coupled or DC-coupled, which qualifies the TDP0604 to be used as a DP++ to HDMI level shifter or HDMI redriver.

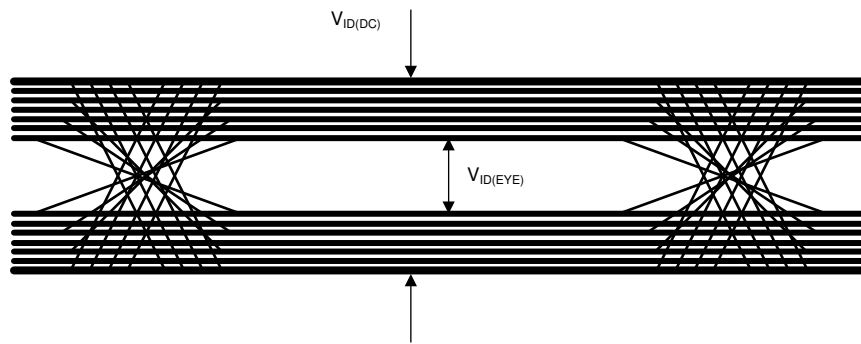
The TDP0604 configuration can be programmed by pin strap or I²C. Receiver equalization, TX pre-emphasis, and TX voltage swing are controlled globally by pin-strap pins such as CTLEMAP_SEL, EQ[1:0], TXSWG, and TXPRE. In I²C mode, all transmitter and receiver settings for each lane are independently controlled. Four TDP0604 devices can be used on one I²C bus with each unique TDP0604 address set by the ADDR pin.

The TDP0604 is a hybrid redriver supporting both source and sink applications. A hybrid redriver can operate either in a linear or limited redriver function. When configured as a limited redriver, the TDP0604 differential output voltage levels are independent of the graphics process unit (GPU) output levels ensuring HDMI compliant levels at the receptacle. The limited redriver is a recommended mode for HDMI source applications. When configured as a linear redriver, the TDP0604 differential output levels are a linear function of the GPU output levels. Linear redriver mode is the recommended mode for sink applications.

For ease of use, the TDP0604 supports single power supply rails of 3.3 V on V_{CC}, integrated HPD level shifter, and DDC buffer eliminating the need for external discrete solutions.

TDP0604 supports up to 16 EQ gain options to compensate for different lengths of input cables or board traces. The EQ gain can be software adjusted by I²C control or pin strapping EQ0 and EQ1 pins. To assist in ease of implementation, the TDP0604 supports lanes swapping; see [# 8.3.4](#). Two temperature gradient versions of the device are available: commercial with a temperature range of 0°C to 70°C (TDP0604) and an industrial temperature range of -40°C to 85°C (TDP0604I).

8.2 Functional Block Diagram

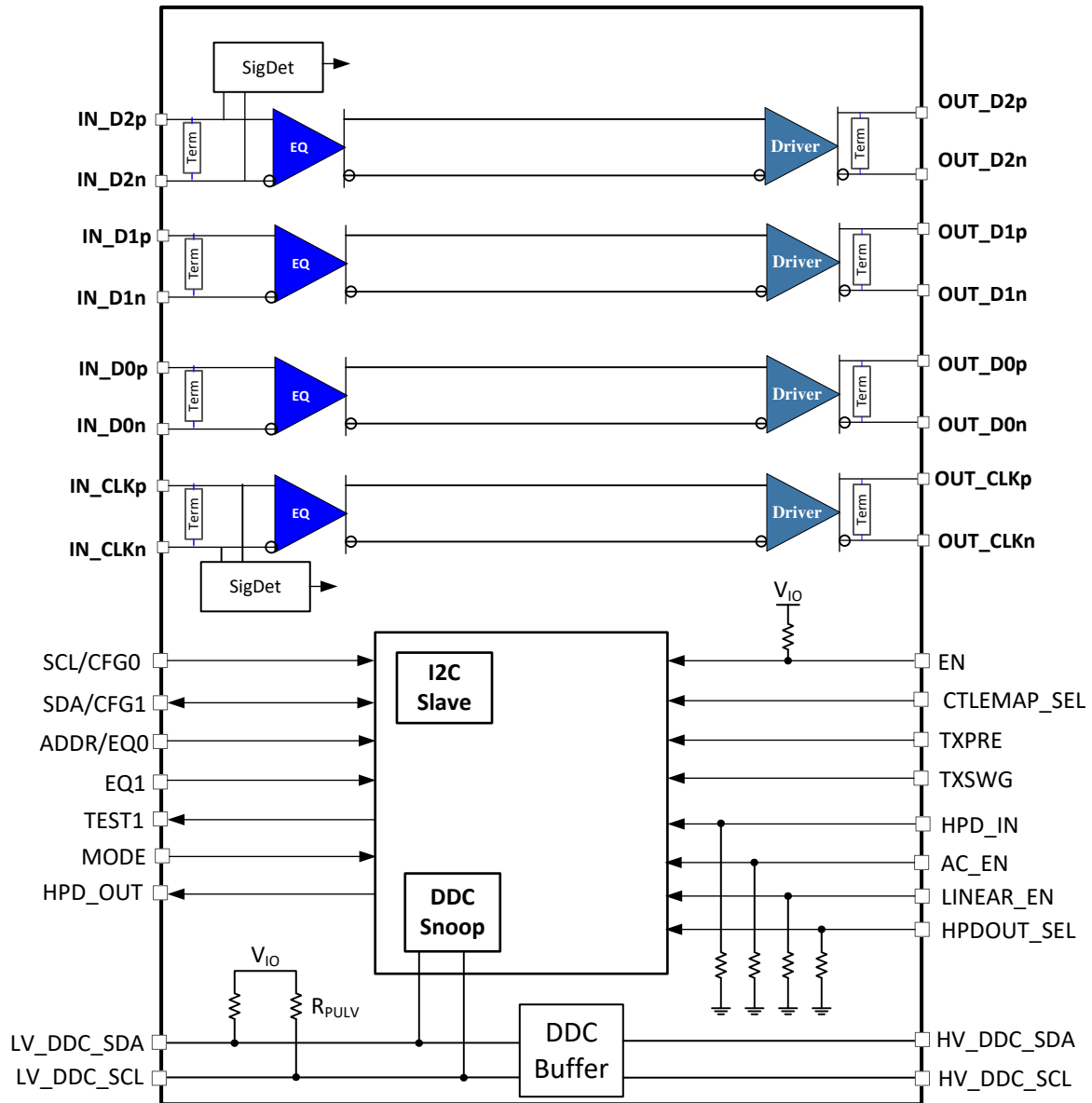

8.3 Feature Description

8.3.1 4-Level Inputs

The TDP0604 has 4-level inputs pins that are used to control the receiver equalization gain, transmitter voltage swing, and pre-emphasis, and place TDP0604 into different modes of operation. These 4-level inputs utilize a resistor divider to help set the 4 valid levels and provide a wider range of control settings. There is an internal pull-up and a pull-down resistors. These resistors, together with the external resistor connection combine to achieve the desired voltage level.

表 8-1. 4-Level Control Pin Settings

LEVEL	SETTINGS
0	Tie 1-k Ω 5% to GND.
R	Tie 20-k Ω 5% to GND.
F	Float (leave pin open)
1	Tie 1-k Ω 5% to V _{CC} .

备注

图 7-1 shows how all 4-level inputs are latched after the rising edge of the EN pin. After these pins are sampled, the internal pull-up and pull-down resistors will be isolated to save power.

8.3.2 I/O Voltage Level Selection

The TDP0604 supports 1.2-V, 1.8-V, and 3.3-V LVCMOS levels. The VIO pin is used to select which voltage level is used for the following 2-level control pins: LV_DDC_SDA, LV_DDC_SCL, SCL/CFG0, and SDA/CFG1.

The AC_EN pin threshold is fixed at 3.3-V LVCMOS levels. EN pin threshold is fixed at 1.2-V LVCMOS threshold.

表 8-2. Selection of LVCMOS Signaling Level

VIO pin	LVCMOS Signaling Level
VALUE < 1.5-V	1.2-V
1.5-V < VALUE < 2.5-V	1.8-V
VALUE > 2.5-V	3.3-V

8.3.3 HPD_OUT

The TDP0604 will level shift 5 V signalling level present on HPD_IN pin to a lower voltage such as 1.8 V or 3.3 V levels on the HPD_OUT pin. The HPD_OUT supports both push-pull and open drain. The default operation is push-pull. Selection between push-pull and open drain is done through the HPDOOUT_SEL register.

When HPD_OUT is configured for push-pull operation, the output level of HPD_OUT is determined by VIO as detailed in 表 8-2. Please note push-pull operation is not supported for VIO less than 1.7 V.

备注

Open-drain operation is only supported when TDP0604 is configured for I2C mode.

When EN pin is low, the HPD_OUT pin will be in a high impedance state. It is recommended to have a weak pull-down resistor (such as 220k) on HPD_OUT.

8.3.4 Lane Control

The TDP0604 has various lane control features. Pin strapping globally controls features like receiver equalization, V_{OD} swing, slew rate, and pre-emphasis or de-emphasis. Through I²C receiver equalization, transmitter swing, and pre-emphasis for each lane can be independently controlled.

8.3.5 Swap

图 8-1 shows how TDP0604 incorporates a swap function which can swap the lanes. The RX EQ, pre-emphasis, termination, and slew configurations will follow the new mapping. This function is supported in pin strap mode as well as when TDP0604 is configured for I²C mode. In I²C mode the swap function is controlled by a register.

表 8-3. Swap Functions

Normal Operation CFG1 pin = L or LANE_SWAP register is 0h	CFG1 = H or LANE_SWAP register is 1h
IN_D2 → OUT_D2	IN_CLK → OUT_CLK
IN_D1 → OUT_D1	IN_D0 → OUT_D0
IN_D0 → OUT_D0	IN_D1 → OUT_D1
IN_CLK → OUT_CLK	IN_D2 → OUT_D2

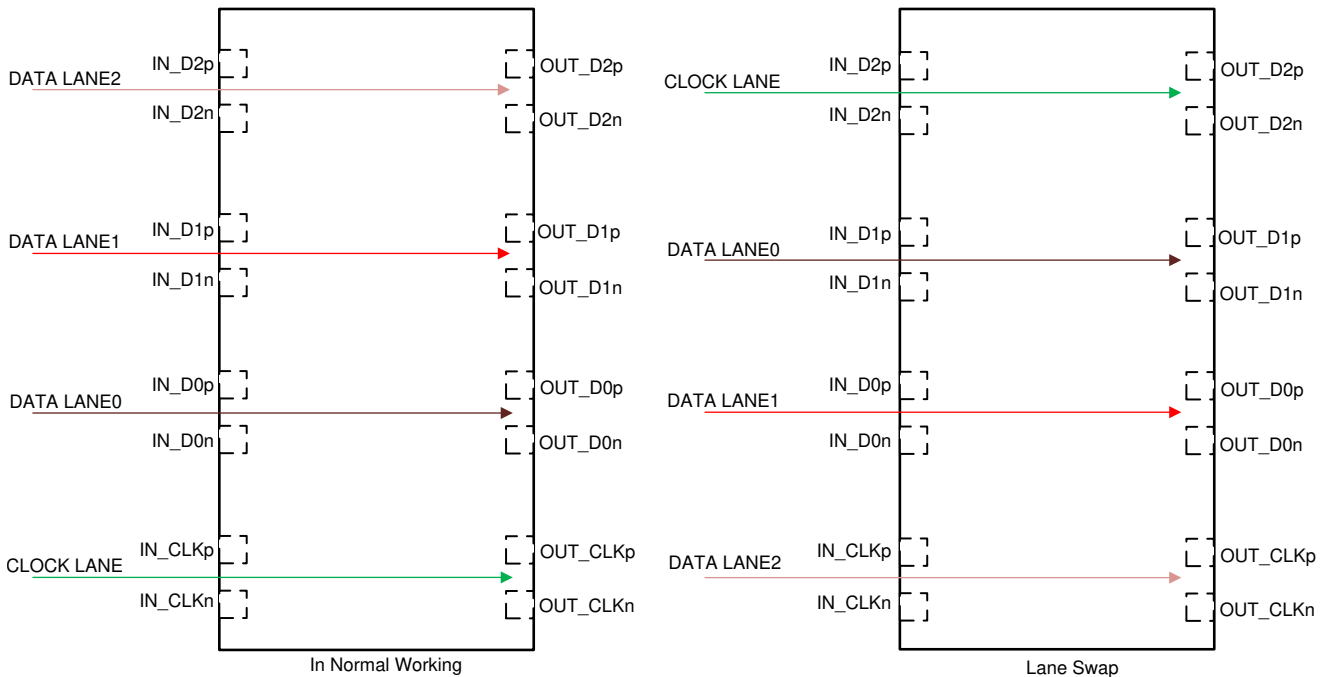

Copyright © 2018, Texas Instruments Incorporated

图 8-1. TDP0604 Swap Function

8.3.6 Linear and Limited Redriver

The TDP0604 supports both linear and limited redriver. Selection between linear and limited can be done from the LINEAR_EN pin in pin-strap mode or through GLOBAL_LINR_EN register in I²C mode.

The limited redriver mode will decouple TDP0604 transmitter's voltage swing, pre-emphasis or de-emphasis, and slew rate from the GPU's transmitter. This allows the GPU to use a lower, power TX setting and depend on TDP0604 transmitter to meet TX compliance requirements. For source applications, it is recommended to configure TDP0604 as a limited redriver. It is not recommended to use limited redriver mode in sink applications.

Unlike limited redriver mode, in linear redriver mode the TDP0604 transmitter's output is not decoupled from the GPU's transmitter. In linear redriver mode, the TDP0604 transmitter's output is a linear function of its input. For HDMI sink applications, it is recommended to configure TDP0604 as a linear redriver.

For HDMI source applications, it is recommended to use TDP0604 in limited redriver mode.

表 8-4. Pin-Strap Mode LINEAR_EN Pin Function

LINEAR_EN Pin Level	Description
1	Limited Enabled
F	Linear Enabled. Recommended for HDMI sink application.
R	Reserved
0	Limited Enabled. Recommended for HDMI source application

8.3.7 Main Link Inputs

Each main link input (IN_D[2:0] and IN_CLK) is internally biased to 3.3-V through approximately 100-Ω (50-Ω single-ended). When using TDP0604 in DisplayPort++ applications, external AC-coupling capacitances should be used. When using TDP0604 in a HDMI application such as in a HDMI monitor, the main link inputs can be DC-coupled to a compliant HDMI transmitter. Each input data channel contains an equalizer to compensate for cable or board losses.

8.3.8 Receiver Equalizer

The equalizer is used to clean up inter-symbol interference (ISI) jitter or loss from the bandwidth-limited board traces or cables. TDP0604 supports fixed receiver equalizer by setting the EQ0 and EQ1 pins or through I²C register.

The TDP0604 has two sets of CTLE curves (3 Gbps CTLE and 6 Gbps CTLE) with each curve having 16 ac gain settings and 3 dc gain settings. The 16 ac gain settings with GLOBAL_DCG = 0x2 is detailed in 表 8-5.

The TDP0604 in pin-strap mode has two CTLE HDMI Datarate Maps: Map B and Map C. These maps are detailed in 表 8-6. The expectation is Map B or C should be used if TDP0604 is used in a source application and Map B for a sink application.

When the TDP0604 is configured for pin-strap mode, the default CTLE HDMI data rate map will be determined by the sampled state of the CTLEMAP_SEL pin as detailed in 表 8-7.

In the I²C mode, the default CTLE (3 Gbps or 6 Gbps) used for each HDMI mode can be controlled from a register.

表 8-5. Receiver EQ Settings when GLOBAL_DCG = 0x2

EQ Setting ⁽¹⁾	RX EQ Level for 3 Gbps CTLE (Gain at 1.5 GHz - Gain at 10 MHz)	RX EQ Level for 6 Gbps CTLE (Gain at 3 GHz - Gain at 10MHz)	EQ1 PIN	EQ0 PIN
0 ⁽²⁾	1.0	0.5	0	0
1	2.0	1.0	0	R
2	3.2	2.4	0	F
3	4.2	3.3	0	1
4	5.3	4.4	F	0
5	6.0	5.2	F	R
6	7.0	6.0	F	F
7	7.7	6.8	F	1
8	9.0	7.5	R	0
9	9.5	8.2	R	R
10	10.0	8.8	R	F
11	10.5	9.3	R	1
12	11.0	10.0	1	0
13	11.5	10.5	1	R
14	12.0	11.0	1	F

表 8-5. Receiver EQ Settings when GLOBAL_DCG = 0x2 (continued)

EQ Setting ⁽¹⁾	RX EQ Level for 3 Gbps CTLE (Gain at 1.5 GHz - Gain at 10 MHz)	RX EQ Level for 6 Gbps CTLE (Gain at 3 GHz - Gain at 10MHz)	EQ1 PIN	EQ0 PIN
15	12.3	11.8	1	1

- (1) In I²C mode, the receiver EQ setting is determined by D0_EQ, D1_EQ, and D2_EQ registers.
(2) When CTLEBYP_EN = 1 and dcGAIN = 0-dB, EQ settings 0 will be 0-dB due to the CTLE is bypassed.

表 8-6. CTLE HDMI Datarate Map B and C

HDMI Mode	Map B	Map C
1.4	3 Gbps CTLE	6 Gbps CTLE
2.0	6 Gbps CTLE	6 Gbps CTLE

表 8-7. Pin-Strap Mode CTLE HDMI Datarate Mapping

CTLE HDMI Datarate Map	Sampled State of CTLEMAP_SEL Pin			
	"0"	"R"	"F"	"1"
	Reserved	Map C	Reserved	Map B

备注

The clock lane EQ when operating in HDMI 1.4 or 2.0 will use the 3-Gbps CTLE and will be set to the zero EQ setting.

8.3.9 CTLE Bypass

The TDP0604 will operate as a buffer when CTLE bypass is enabled. In pin-strap mode, this feature is disabled. In I²C mode, this feature is enabled when CTLEBYP_EN = 1h and GLOBAL_DCG = 2h. Any lane that has EQ setting of 0h that lane will operate in CTLE bypass.

8.3.10 Input Signal Detect

When standby is enabled, the TDP0604 looks for a signal on IN_CLK (SWAP disabled) or IN_D2 (SWAP enabled) and is fully functional when a signal is detected. If no signal is detected, the device reenters standby mode waiting for a signal again. In the standby state all of the TMDS outputs are in high-Z status. In both pin-strap mode and I²C mode standby is enabled by default. In I²C mode standby can be disabled by setting the STANDBY_DISABLE register.

8.3.11 Main Link Outputs

8.3.11.1 Transmitter Bias

The TDP0604 transmitter supports both external (DC-coupled) and internal bias (AC-coupled) to a receiver. Selection between DC and AC-coupled is done through use of the AC_EN pin in pin-strap mode and TX_AC_EN register in I²C mode. The AC_EN pin informs the TDP0604 whether or not an external ac-coupling capacitor is present. When AC_EN is greater than VIH, then TDP0604 transmitters are internally biased to approximately V_{CC}. For AC-coupled application, the AC_EN pin should be connected to greater than VIH and an external ac-coupling capacitor should be placed on each of the OUT_D[2:0] pins and the OUT_CLK pin. If the AC_EN pin is connected to less than VIL, then will inform TDP0604 it is DC-coupled (externally biased) to the far-end HDMI compliant receiver.

备注

If using AC-coupled TX mode (AC_EN = high) in an HDMI source application, an external 499 Ω pull-down to GND must be placed on each OUT pin (OUT_D2:0p/n and OUT_CLKp/n) between the ac-coupling capacitor and the HDMI receptacle. The purpose of the 499 Ω resistor is to set the common mode voltage to HDMI compliant levels. Refer to 图 8-3.



图 8-2. DC-Coupled TX in HDMI Source Application (AC_EN = Low). External ESD Not Shown.



图 8-3. AC-Coupled TX in HDMI Source Application (AC_EN = High). External ESD Not Shown.

8.3.11.2 Transmitter Impedance Control

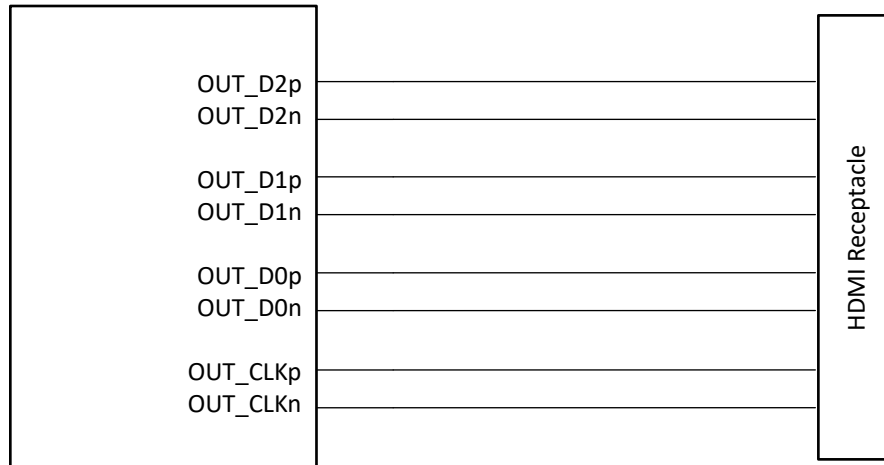
HDMI 2.0 standards requires a source termination impedance approximately 100 Ω for data rates > 3.4 Gbps. HDMI 1.4b requires no source termination but has a provision for termination for higher data rates greater than 1.65 Gbps. Enabling this termination is optional. The TDP0604 terminations are controlled automatically as depicted in 表 8-9 when in pin strap mode. Depending on the MODE pin, the CFG0 pin can be used to select the HDMI 1.4 termination between open and 300-Ω .

The TDP0604 supports automatic selection between open and 300-Ω termination when operating in HDMI1.4. In pin-strap mode with CTL0 low, the TDP0604 will enable open termination when HDMI clock frequency is less than $f_{\text{HDMI14_open}}$ and will enable 300-Ω termination when HDMI clock frequency is greater than $f_{\text{HDMI14_300}}$. In I2C mode, this feature is controlled by the TXTERM_AUTO_HDMI14 register.

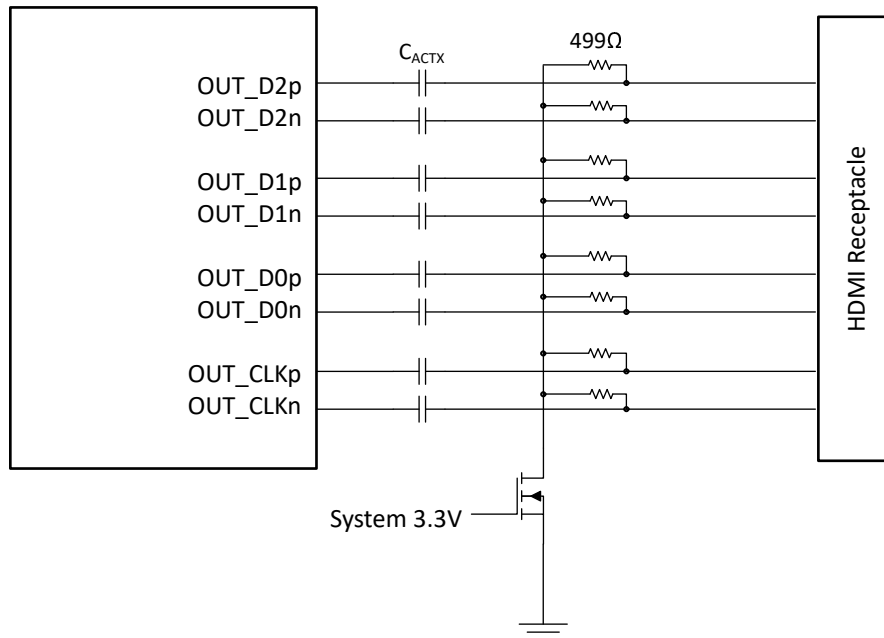
In I²C mode termination is controlled through registers as described by 表 8-8.

表 8-8. Source Termination Control in I2C mode

TX_AC_EN Register	TERM Register	TXTERM_AUTO_HDMI14 Register	Source Termination
0	00	X	None
0	01	X	Parallel $\approx 300\text{-}\Omega$ across P and N
0	10	X	Automatic. parallel $\approx 100\text{-}\Omega$ across P and N
0	10	1	Automatic. HDMI 1.4. parallel $\approx 300\text{-}\Omega$ across P and N
0	10	0	Automatic. HDMI 1.4. No termination if HDMI clock frequency is $\leq f_{\text{HDMI14_open}}$.
0	10	0	Automatic. HDMI 1.4. Parallel $\approx 300\text{-}\Omega$ across P and N termination if HDMI clock frequency is $\geq f_{\text{HDMI14_300}}$.
0	11	X	Parallel $\approx 100\text{-}\Omega$ across P and N
1	00	X	$\approx 150\text{-}\Omega$ to supply (V_{CC}) on both P and N
1	01	X	$\approx 150\text{-}\Omega$ to supply (V_{CC}) on both P and N
1	10	X	Automatic. $\approx 150\text{-}\Omega$ to supply (V_{CC}) on both P and N for HDMI 1.4. Otherwise $\approx 50\text{-}\Omega$ to supply (V_{CC}) on both P and N.
1	11	X	$\approx 50\text{-}\Omega$ to supply (V_{CC}) on both P and N

表 8-9. Automatic Source Termination Control in Pin-Strap Mode

HDMI Mode	AC_EN pin	Source Termination
HDMI 1.4	0	None or parallel $\approx 300\text{-}\Omega$ across P and N depending on state of SCL/CFG0 pin
HDMI 2.0	0	Parallel $\approx 100\text{-}\Omega$ across P and N
HDMI 1.4	1	$\approx 150\text{-}\Omega$ to supply (V_{CC}) on both P and N
HDMI 2.0	1	$\approx 50\text{-}\Omega$ to supply (V_{CC}) on both P and N

8.3.11.3 TX Slew Rate Control

The TDP0604 has the ability to slow down the TMDS output edge rates. In pin-strap mode the TX slew rate can not be controlled. In I²C mode both clock and data lanes slew rate can be controlled from a register. 表 8-10 shows the supported settings for each slew rate register based on HDMI data rate. The TDP0604 must be configured in limited redriver mode to control the TX slew rate.

表 8-10. I²C Mode TX Slew Register Supported Settings

HDMI Datarate	SLEW_CLK register	SLEW_3G register	SLEW_6G register
HDMI 1.4	3'b000 through 3'b011	3'b010 through 3'b101	N/A
HDMI 2.0	3'b000 through 3'b011	N/A	3'b011 through 3'b110

8.3.11.4 TX Pre-Emphasis and De-Emphasis Control

The TDP0604 provides pre-emphasis and de-emphasis on the data lanes allowing the output signal pre-conditioning to offset interconnect losses between the TDP0604 outputs and a TMDS receiver. Pre-emphasis and de-emphasis is not implemented on the clock lane. There are two methods to implement pre-emphasis, pin strapping or through I²C programming. TX pre-emphasis and de-emphasis control is only supported in limited mode.

When using pin strap mode, the TXPRE pin controls four different global pre-emphasis and de-emphasis values for all data lanes when TDP0604 is operating in HDMI 1.4 or HDMI 2.0. These pre-emphasis and de-emphasis values are described in 表 8-11.

表 8-11. Pin-Strap TXPRE Pin Function

TXPRE Pin	HDMI 1.4 or HDMI 2.0
0	3.5 dB pre-emphasis
R	-2.5 dB de-emphasis
F	0 dB
1	6.0 dB pre-emphasis

8.3.11.5 TX Swing Control

The TDP0604 transmitter swing level can be adjusted in both pin strap and I²C mode. In I²C mode, TX swing settings are controlled independently for each lane (both clock and data) through registers.

In I²C mode, the TX swing used when operating in HDMI 1.4 and HDMI 2.0 can be independently controlled through HDMI14_VOD and HDMI20_VOD registers.

In pin strap mode with limited enabled, the TXSWG pin adjusts the default 1000 mV swing as detailed in 表 8-12. In HDMI 1.4 the TXSWG pin controls the swing for both the data and clock lanes. In HDMI 2.0, the TXSWG pin controls the swing for data lanes while the clock lane will remain at default value.

In pin-strap mode with linear enabled, the linearity range is fixed at the highest level (1200 mVpp) and therefore TXSWG pin is not used. In I²C mode, the linearity range can be adjusted from a register.

表 8-12. Pin Strap TXSWG Control

TXSWG pin	Limited Mode for HDMI 1.4	Limited Mode for HDMI 2.0	Linear Mode
0	Default (1000 mVpp)	Default (1000 mVpp)	1200 mVpp
R	Default - 5%	Default - 5%	1200 mVpp
F	Default (1000 mVpp)	Default (1000 mVpp)	1200 mVpp
1	Default (1000 mVpp)	Default + 5%	1200 mVpp

8.3.12 DDC Buffer

The TDP0604 has a DDC buffer for capacitance isolation and for shifting 5-V levels present on the HDMI connector to as low as 1.2-V levels on the GPU source side. The HV_DDC_SDA and HV_DDC_SCL pins support 5-V levels while the LV_DDC_SDA and LV_DDC_SCL pins support 1.2-V, 1.8-V, and 3.3-V levels. When the DDC buffer is used in source application, the HV side must be pulled up using 1.5 k to 2 k-Ω resistors. It is recommended to use 1.8 k-Ω ±5% resistor. HV_DDC_SDA and HV_DDC_SCL pins will typically be pulled up to HDMI 5 V. The LV_DDC_SDA and LV_DDC_SCL are internally pulled up to VIO.

The TDP0604 enables DDC translation from low voltage (system side) voltage levels to 5-V (HDMI cable side) voltage levels without degradation of system performance. The TDP0604 contains 2 bidirectional, open-drain buffers specifically designed to support up and down-translation between the low voltage (LV) side DDC-bus and the high voltage (HV) 5-V DDC-bus. The HV I/Os (HV_DDC_SCL and HV_DDC_SDA) are overvoltage tolerant to 5.5 V. After HPD_IN high, a LOW level on LV side (below VILC = 0.08 × VIO) turns the corresponding HV driver (either SDA or SCL) on and drives HV side down to V_{HVOL}. When LV side rises above approximately 0.10 × VIO, the HV pulldown driver is turned off and the internal pullup resistor pulls the pin HIGH. When HV side falls first and goes below 1.6-V, a CMOS hysteresis input buffer detects the falling edge, turns on the LV driver, and pulls LV down to approximately V_{LVOL} = 0.16 × VIO. The LV side pulldown is not enabled unless the LV voltage goes below VILC. If the LV side low voltage goes below VILC, the HV side pulldown driver is enabled until LV side rises above (VILC + ΔVT-HYST), then HV side, if not externally driven LOW, continues to rise being pulled up by the external pullup resistor.



图 8-4. DDC Buffer Block Diagram

图 8-5 shows the connection of the LV and HV DDC pins when using the DDC buffer. This connection is supported in pin-strap mode when MODE pin is "0" or "1". In I2C mode, the DDCBUF_EN register must be set to enable the DDC Buffer.

备注

The TDP0604 has integrated pullups to VIO on the DDC LV pins. Therefore, no external pull-ups shall be present between the TDP0604's DDC LV pins and DDC master when using TDP0604's DDC buffer.

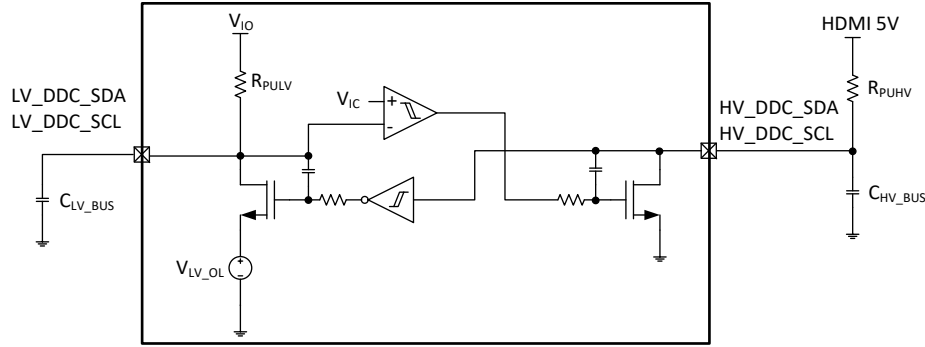

图 8-5. Source Application: DDC Buffer Enabled

图 8-6 shows an example source application of snooping from the HV DDC pins. In this example, the DDC buffer must be enabled and the LV DDC pins must be floating. This connection is supported in pin-strap mode when MODE pin is "0" or "1". In I2C mode, the DDCBUF_EN register must be set to enable the DDC Buffer.

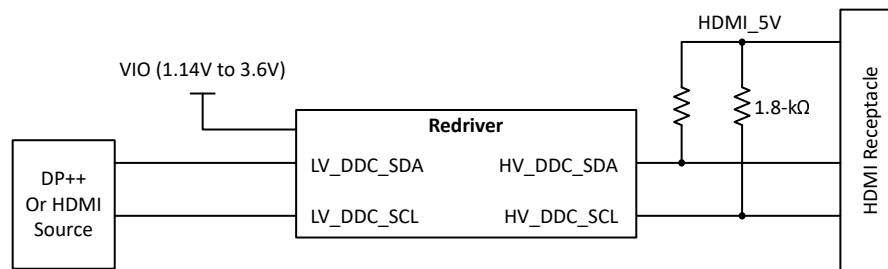

图 8-6. Source Application: DDC Buffer Enabled and Snoop from HV DDC pins

图 8-7 shows an example source application of snooping from the LV DDC pins. In this example, the DDC buffer must be disabled and the HV DDC pins must be floating. This connection is supported in pin-strap mode when MODE pin is "R". In I2C mode, the DDCBUF_EN register must be cleared to disable the DDC Buffer.

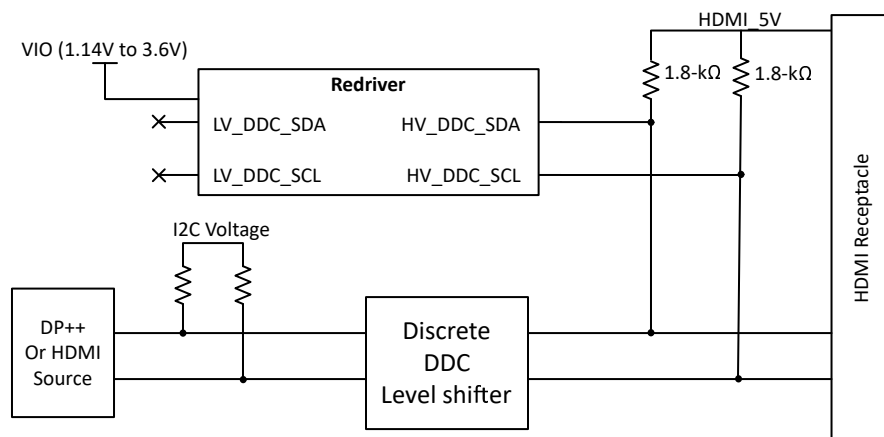

图 8-7. Source Application: DDC Buffer Disabled and Snoop from LV DDC pins

图 8-8 shows the connection of the LV and HV DDC pins when using the DDC buffer in a sink application. This connection is supported in pin-strap mode when MODE pin is "0" or "1". In I2C mode, the DDCBUF_EN register must be set to enable the DDC Buffer.

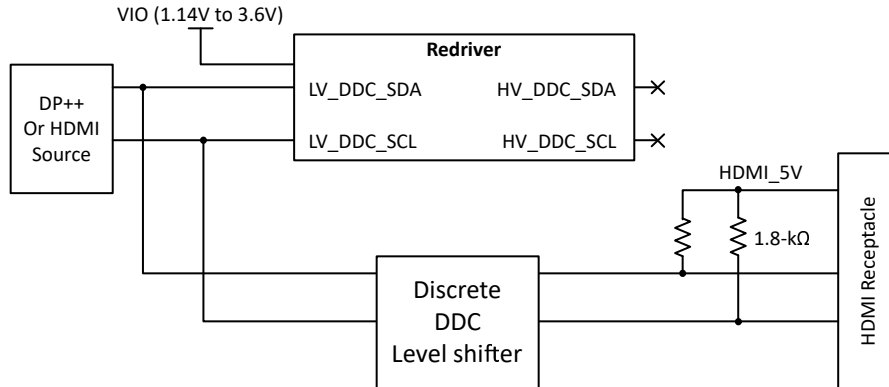

图 8-8. Sink Application: DDC Buffer Enabled

图 8-9 shows an example sink application of snooping from the LV DDC pins. In this example, the DDC buffer must be disabled and the HV DDC pins must be floating. This connection is supported in pin-strap mode when MODE pin is "R". In I2C mode, the DDCBUF_EN register must be cleared to disable the DDC Buffer.

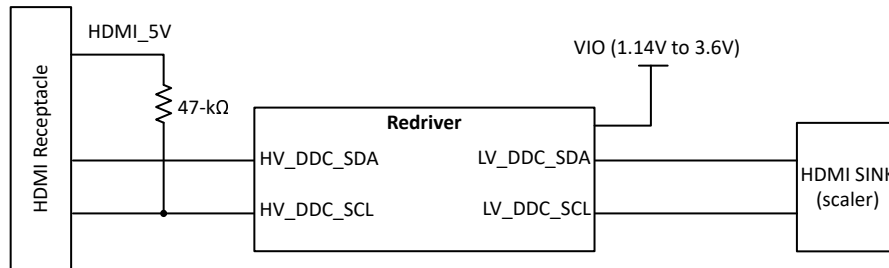

图 8-9. Sink Application: DDC Buffer Disabled and Snoop from LV DDC pins

Figure 8-10 shows an example sink application of snooping from the HV DDC pins. In this example, the DDC buffer must be enabled and the LV DDC pins must be floating. This connection is supported in pin-strap mode when MODE pin is "0" or "1". In I2C mode, the DDCBUF_EN register must be set to enable the DDC Buffer.

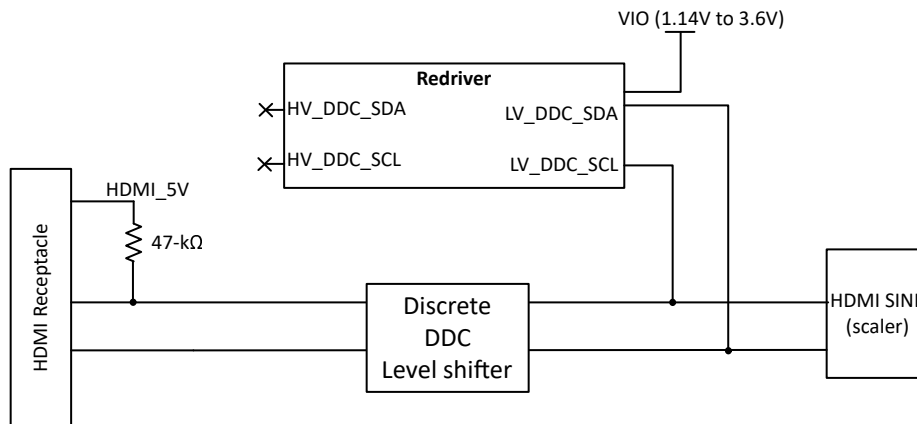
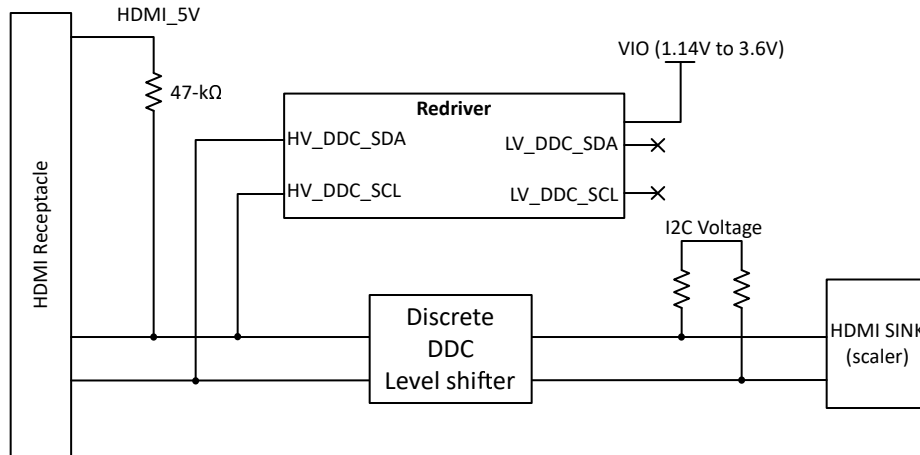

Figure 8-10. Sink Application: DDC Buffer Enable and Snoop from HV DDC pins

8.3.13 HDMI DDC Capacitance

The HDMI specification limits the DDC bus capacitance to ≤ 50 pF for both a HDMI source and sink. Therefore, care must be taken to make sure the total capacitance of all components (TDP0604, FR4 trace, ESD, Source, and Sink) is less than 50 pF.

The TDP0604's DDC Buffer offers capacitance isolation between the LV DDC pins and the HV DDC pin. The total capacitance of components, including the FR4 trace, between the TDP0604 HV_DDC_SDA/SCL pins and the HDMI receptacle must be $\leq (50 \text{ pF} - C_{IOHV})$.

If implementing a DDC level shifter using pass gates, then the total capacitance will include all components between source or sink and the HDMI receptacle. These components include and not limited to Source or Sink, the FR4 trace, ESD components, and TDP0604.

备注

Trace capacitance can be in the range of 2 to 5 pF per inch. A general rule of thumb is a 50- Ω FR4 trace will be around 3.3 pF per inch.

8.4 Device Functional Modes

8.4.1 MODE Control

The MODE pin provides four modes of operation. There are three pin-strap modes and one I²C mode. In all three pin strap modes, DDC snooping feature is enabled. In I²C mode, DDC snoop feature is enabled by default but can be disabled by a register.

8.4.1.1 I²C Mode (MODE = "F")

In I²C mode all settings of the TDP0604 can be controlled through the registers. The TDP0604 7-bit I2C address is determined by the ADDR/EQ0 pin. All other 4-level and 2-level pins are not used in I²C mode since the functions exist in a register. The SCL/CFG0 pin will function as the I²C clock and the SDA/CFG1 pin will function as the I²C data.

The TDP0604 defaults to power down in I²C mode. Upon completion of initialization of the TDP0604, software must clear the PD_EN field to exit the power down state. The HPD_OUT pin will be asserted low while the PD_EN register is set.

The TDP0604 supports 1.2-V, 1.8-V, and 3.3-V I²C signaling levels. Selection of 1.2-V, 1.8-V, or 3.3-V is determined by the VIO pin as described in [表 8-2](#).

8.4.1.2 Pin Strap Modes

In pin-strap mode, the SCL/CFG0 and the SDA/CFG1 pins will be used to control the HDMI 1.4 termination, lane SWAP function, and the DisplayPort mode as described in [表 8-13](#) and [表 8-14](#).

表 8-13. SCL/CFG0 Pin in Pin-Strap Mode

SCL/CFG0 Pin	AC_EN Pin	TDP0604 Function
0	0	HDMI 1.4 termination is open if HDMI clock frequency $\leq f_{\text{HDMI14_open}}$
0	0	HDMI 1.4 termination is $\approx 300\text{-}\Omega$ if HDMI clock frequency $\geq f_{\text{HDMI14_300}}$
1	0	HDMI 1.4 termination is $\approx 300\text{-}\Omega$
0	1	Normal HDMI. Function determined by MODE pin.
1	1	DisplayPort mode. DDC snoop disabled. All four lanes enabled when HPD_IN is high.

表 8-14. SDA/CFG1 Pin in Pin-Strap Mode

SDA/CFG1 Pin	TDP0604 Function
0	Normal Lane ordering
1	Lane Swap enabled.

备注

The SCL/CFG0 is the only two-level pin that is continuously sampled in pin-strap mode. AC_EN, HPDOUT_SEL, and SDA/CFG1 will not be continuously sampled in pin-strap mode unless indicated otherwise.

8.4.1.2.1 Pin-Strap: HDMI 1.4 and HDMI 2.0 Functional Description

The TDP0604 will always use the sampled state of EQ[1:0] pins when operating in either HDMI 1.4 and HDMI 2.0. The amount of EQ applied is determined by the CTLE Map used (refer to [节 8.3.8](#)).

If TDP0604 is configured for limited redriver mode, the OUT_D[2:0] and OUT_CLKP/N levels will be fixed based on the sampled state of TXSWG pin (refer to [表 8-12](#)) and TXPRE pin (refer to [表 8-11](#)).

If TDP0604 is configured for linear redriver mode, OUT_D[2:0] and OUT_CLK will be a linear function of the input signals.

表 8-15. MODE Pin Function

MODE Pin Level	Description
0	Pin Strap with DDC Buffer enabled
R	Pin Strap with DDC Buffer disabled.
F	I2C mode
1	Reserved.

备注

In source application, it is recommended to use limited redriver mode for both HDMI 1.4 and HDMI 2.0.

8.4.2 DDC Snoop Feature

As part of discovery the source reads the sink E-EDID information to understand the sink's capabilities. Part of this read is HDMI Forum Vendor Specific Data Block (HF-VSDB) located at slave address 0xA8. From the LV_DDC_SDA and LV_DDC_SCL pins the TDP0604 DDC snoop function will monitor both reads and writes to TMDS Configuration at offset 20h of the Status and Control Data Channel Structure (SCDCS) located within the HF-VSDB. The DDC snoop function resides on the LV_DDC_SDA and LV_DDC_SCL pins.

The TDP0604 has similar SCDCS registers within its register space. Through TDP0604 local I²C interface, external microprocessor can control TDP0604 to perform all the necessary functions required for each HDMI type.

8.4.2.1 HDMI Type

The TDP0604 monitors offset 20h in order to determine HDMI type as either HDMI 1.4 or HDMI 2.0, as described in [表 8-16](#).

表 8-16. HDMI Type Selection

HDMI Type	TMDS_CLK_RATIO SCDCS Offset 20h[1]
HDMI 1.4 (TMDS x10)	0
HDMI 2.0 (TMDS x40)	1

备注

TDP0604 will default to HDMI 1.4 following a power-on reset or whenever it enters the powerdown state. Upon exiting standby, the TDP0604 will hold data rate value (HDMI 1.4 or 2.0) prior to entering the standby.

8.4.3 Low Power Modes

The TDP0604 has two low power modes: Power Down and Standby. Both lower power modes are detailed in 表 8-17. Power down is entered when HPD_IN is low for $t_{HPD_PWRDOWN}$ or in I²C if PD_EN bit is set. Power down is also entered when the EN pin is low. The TDP0604 will exit power down to the standby state when HPD_IN is high for $t_{HPD_STANDBY}$.

The TDP0604 implements a two stage standby power process when HPD_IN is high.

Stage 1: If there is no signal (electrical idle) on the IN_CLK lane, the TDP0604 will enter standby mode within $t_{STANDBY_ENTRY}$.

Stage 2: If a signal is detected which last longer than t_{SIGDET_DB} , then TDP0604 will declare a valid signal and exit standby within t_{STANDY_EXIT} .

- If a signal is detected, the TDP0604 will go into normal active operation and signals present at IN_CLK and IN_D[2:0] inputs will be passed through to the OUT_CLK and OUT_D[2:0] outputs.
- If it is determined that no signal is present, the TDP0604 will re-enter stage 1.

The TDP0604 will exit normal operation and return to the standby state within $t_{STANDBY_ENTRY}$ anytime the electrical idle is detected.

表 8-17. Power Modes

EN pin	INPUTS					STATUS					
	HPD_IN pin	STANDBY_DISABLE register	HPD_PWRDN_N_DISABLE register	PD_EN register	HDMI 1.4/2.0: IN_CLK pin	HPD_OUT pin	IN_Dx pins	SDA/SCL	OUT_Dx OUT_CLK	DDC	Mode
L	X	X	X	X	X	High-Z	High-Z	Disabled	High-Z	Disabled	Power Down Mode
H	L	X	0	0	X	L	High-Z	Active	High-Z	Disabled	Power Down Mode
H	X	X	X	1	X	L	High-Z	Active	High-Z	Disabled	Power Down Mode
H	H	1	X	0	X	HPD_IN	All RX Active	Active	TX Active	Active	Normal operation
H	X	1	1	0	X	H	All RX Active	Active	TX Active	Active	Normal operation
H	H	0	X	0	No signal	HPD_IN	HDMI 1.4/2.0: IN_CLK Active	Active	High-Z	Active	Standby Mode (Squelch waiting)
H	H	0	X	0	Valid signal detected	HPD_IN	All RX Active	Active	TX Active	Active	Normal operation
H	X	0	1	0	No signal	H	HDMI 1.4/2.0: IN_CLK Active	Active	High-Z	Active	Standby Mode (Squelch waiting)
H	X	0	1	0	Valid signal detected	H	All RX Active	Active	TX Active	Active	Normal operation

8.5 Programming

8.5.1 Pseudocode Examples

These are examples of configuring TDP0604 when it is configured for I2C mode.

8.5.1.1 HDMI 2.0 Source Example with DDC Snoop and DDC Buffer Enabled

When using TDP0604's DDC buffer with snooping enabled, this example can be used.

This example will initialize the following:

- Limited redriver mode with DC-coupled output.
- TX slew rate for each data rate
- CTLE used for each data rate.
- Receiver EQ setting for each lane (D0, D1, and D2).
- TX voltage swing for each lane (clock, D0, D1, and D2).
- TX pre-emphasis/de-emphasis for HDMI 1.4 and 2.0.

```
// (address, data)
// Initial power-on configuration.
(0x0A, 0x0A), // Rate snoop and TXFFE snoop enabled.
(0x0B, 0x34), // 3G and 6G slew rate control
(0x0C, 0x71), // HDMI clock slew rate
(0x0D, 0x22), // Limited mode, DC-coupled TX, 0dB DCG, Auto Term, disable CTLE bypass
(0x0E, 0x05), // HDMI1.4 and 2.0 CTLE selection
(0x10, 0x03), // Enabled DDC DCC correction and DDC buffer
(0x11, 0x0F), // HDMI1.4 and 2.0 VOD controlled per lane
(0x12, 0x03), // Clock lane VOD
(0x14, 0x03), // D0 lane VOD and TXFFE.
(0x15, 0x0Y), // D0 lane EQ. Set "Y" to desired value.
(0x16, 0x03), // D1 lane VOD and TXFFE.
(0x17, 0x0Y), // D1 lane EQ. Set "Y" to desired value.
(0x18, 0x03), // D2 lane VOD and TXFFE.
(0x19, 0x0Y), // D2 lane EQ. Set "Y" to desired value.
(0x09, 0x00), // Take out of PD state. Should be done after initialization is complete.
```

8.5.2 TDP0604 I²C Address Options

For further programmability, the TDP0604 can be controlled using I²C. The SCL/CFG0 and SDA/CFG1 terminals are used for I²C clock and I²C data respectively.

表 8-18. TDP0604 I²C Device Address Description

ADDR/EQ0 pin	Bit 7 (MSB)	Bit 6	Bit 5	Bit 4	Bit 3	Bit 2	Bit 1	Bit 0 (W/R)	HEX
0	1	0	1	1	1	1	0	0/1	BC/BD
R	1	0	1	1	1	0	1	0/1	BA/BB
F	1	0	1	1	1	0	0	0/1	B8/B9
1	1	0	1	1	0	1	1	0/1	B6/B7

8.5.3 I²C Slave Behavior



图 8-11. I²C Write with Data

The following procedure should be followed to write data to TDP0604 I²C registers (refer to 图 8-11):

1. The master initiates a write operation by generating a start condition (S), followed by the TDP0604 7-bit address and a zero-value “W/R” bit to indicate a write cycle.
2. The TDP0604 acknowledges the address cycle.

- The master presents the register offset within TDP0604 to be written, consisting of one byte of data, MSB-first.
- The TDP0604 acknowledges the sub-address cycle.
- The master presents the first byte of data to be written to the I²C register.
- The TDP0604 acknowledges the byte transfer
- The master may continue presenting additional bytes of data to be written, with each byte transfer completing with an acknowledge from the TDP0604.
- The master terminates the write operation by generating a stop condition (P).

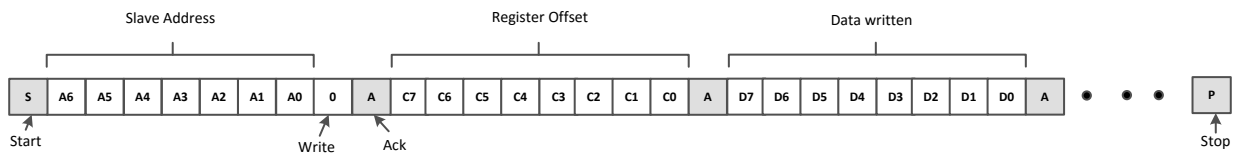

图 8-12. I2C Read without repeated Start

The following procedure should be followed to read the TDP0604 I²C registers without a repeated Start (refer to 图 8-12).

- The master initiates a read operation by generating a start condition (S), followed by the TDP0604 7-bit address and a zero-value “W/R” bit to indicate a read cycle.
- The TDP0604 acknowledges the 7-bit address cycle.
- Following the acknowledge the master continues sending clock.
- The TDP0604 transmit the contents of the memory registers MSB-first starting at register 00h or last read register offset+1. If a write to the I²C register occurred prior to the read, then the TDP0604 shall start at the register offset specified in the write.
- The TDP0604 waits for either an acknowledge (ACK) or a not-acknowledge (NACK) from the master after each byte transfer; the I²C master acknowledges reception of each data byte transfer.
- If an ACK is received, the TDP0604 transmits the next byte of data as long as master provides the clock. If a NAK is received, the TDP0604 stops providing data and waits for a stop condition (P).
- The master terminates the write operation by generating a stop condition (P).

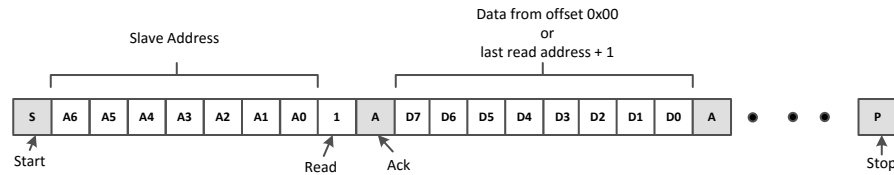

图 8-13. I2C Read with repeated Start

The following procedure should be followed to read the TDP0604 I²C registers with a repeated Start (refer to 图 8-13).

- The master initiates a read operation by generating a start condition (S), followed by the TDP0604 7-bit address and a zero-value “W/R” bit to indicate a write cycle.
- The TDP0604 acknowledges the 7-bit address cycle.
- The master presents the register offset within TDP0604 to be written, consisting of one byte of data, MSB-first.
- The TDP0604 acknowledges the register offset cycle.
- The master presents a repeated start condition (Sr).

6. The master initiates a read operation by generating a start condition (S), followed by the TDP0604 7-bit address and a one-value “W/R” bit to indicate a read cycle.
7. The TDP0604 acknowledges the 7-bit address cycle.
8. The TDP0604 transmit the contents of the memory registers MSB-first starting at the register offset.
9. The TDP0604 shall wait for either an acknowledge (ACK) or a not-acknowledge (NACK) from the master after each byte transfer; the I²C master acknowledges reception of each data byte transfer.
10. If an ACK is received, the TDP0604 transmits the next byte of data as long as master provides the clock. If a NAK is received, the TDP0604 stops providing data and waits for a stop condition (P).
11. The master terminates the read operation by generating a stop condition (P).

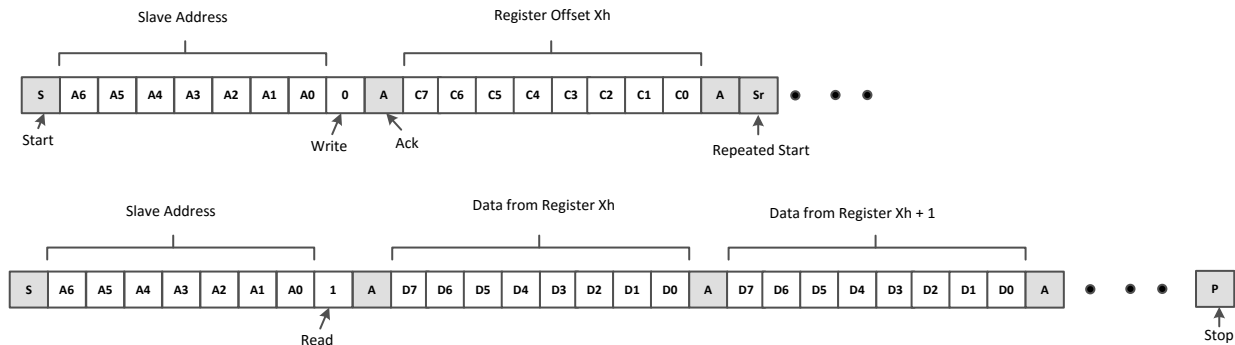

图 8-14. I2C Write without data

The following procedure should be followed for setting a starting sub-address for I²C reads (refer to 图 8-14).

1. The master initiates a write operation by generating a start condition (S), followed by the TDP0604 7-bit address and a zero-value “W/R” bit to indicate a write cycle.
2. The TDP0604 acknowledges the address cycle.
3. The master presents the register offset within TDP0604 to be written, consisting of one byte of data, MSB-first.
4. The TDP0604 acknowledges the register offset cycle.
5. The master terminates the write operation by generating a stop condition (P).

备注

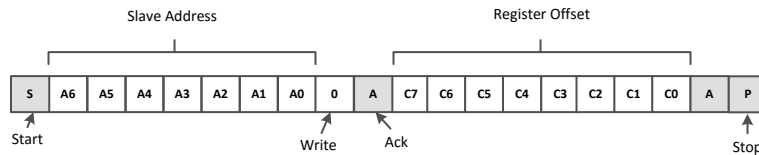
After initial power-up, if no register offset is included for the read procedure (refer to 图 8-12), then reads start at register offset 00h and continue byte by byte through the registers until the I²C master terminates the read operation. During a read operation, the TDP0604 auto-increments the I²C internal register address of the last byte transferred independent of whether or not an ACK was received from the I²C master.

8.6 Register Maps

8.6.1 TDP0604 Registers

[TDP0604 Registers](#) lists the memory-mapped registers for the TDP0604 registers. All register offset addresses not listed in [TDP0604 Registers](#) should be considered as reserved locations and the register contents should not be modified.

表 8-19. TDP0604 Registers

Offset	Acronym	Register Name	Section
8h	REV_ID	Revision ID	节 8.6.1.1
9h	PD_RST	Power Down and Reset control	节 8.6.1.2
Ah	MISC_CONTROL	Misc Control	节 8.6.1.3
Bh	GBL_SLEW_CTRL	Global TX Slew control for data lanes in HDMI1.4 and 2.0	节 8.6.1.4
Ch	GBL_SLEW_CTRL2	Global TX Slew control for data and clock	节 8.6.1.5
Dh	GBL_CTRL1	Global control	节 8.6.1.6
Eh	GBL_CTL1_CTRL	Global CTLE control	节 8.6.1.7
10h	DDC_CFG	DDC Buffer controls	节 8.6.1.8
11h	LANE_ENABLE	Lane enables	节 8.6.1.9
12h	CLK_CONFIG1	CLK lane TX swing control	节 8.6.1.10

表 8-19. TDP0604 Registers (continued)

Offset	Acronym	Register Name	Section
14h	D0_CONFIG1	D0 lane TX swing and FFE control	节 8.6.1.11
15h	D0_CONFIG2	D0 lane RX EQ control	节 8.6.1.12
16h	D1_CONFIG1	D1 lane TX swing and FFE control	节 8.6.1.13
17h	D1_CONFIG2	D1 lane RX EQ control	节 8.6.1.14
18h	D2_CONFIG1	D2 lane TX swing and FFE control	节 8.6.1.15
19h	D2_CONFIG2	D2 lane RX EQ control	节 8.6.1.16
1Ah	SIGDET_TH_CFG	SIGDET voltage threshold control	节 8.6.1.17
1Ch	GBL_STATUS	Global Powerdown and Standby Status	节 8.6.1.18
20h	SCDC_TMDS_CONFIG	SCDC TMDS Clock Ratio	节 8.6.1.19

Complex bit access types are encoded to fit into small table cells. [TDP0604 Access Type Codes](#) shows the codes that are used for access types in this section.

表 8-20. TDP0604 Access Type Codes

Access Type	Code	Description
Read Type		
H	H	Set or cleared by hardware
R	R	Read
RH	R H	Read Set or cleared by hardware
Write Type		
W	W	Write
W1S	W 1S	Write 1 to set
WtoP	W	Write
Reset or Default Value		
-n		Value after reset or the default value

8.6.1.1 REV_ID Register (Offset = 8h) [Reset = 03h]

REV_ID is shown in [REV_ID Register Field Descriptions](#).

Return to the [TDP0604 Registers](#).

表 8-21. REV_ID Register Field Descriptions

Bit	Field	Type	Reset	Description
7-0	REV_ID	RH	3h	Device revision.

8.6.1.2 PD_RST Register (Offset = 9h) [Reset = 01h]

PD_RST is shown in [PD_RST Register Field Descriptions](#).

Return to the [TDP0604 Registers](#).

表 8-22. PD_RST Register Field Descriptions

Bit	Field	Type	Reset	Description
7	SOFT_RST	HWtoP	0h	Writing a 1 to this field resets all fields
6	SCDC_SOFT_RST	HWtoP	0h	Writing a 1 to this field resets the SCDC register 20h.

表 8-22. PD_RST Register Field Descriptions (continued)

Bit	Field	Type	Reset	Description
5	RESERVED	R	0h	Reserved
4	RESERVED	R/W	0h	Reserved
3	RESERVED	R	0h	Reserved
2	HPD_PWRDWN_DISABLE	R/W	0h	Mode to ignore HPD pin and always enter active state unless PD_EN is high 0h = Automatically enter power down based on HPD_IN 1h = Always remain in active state or Standby
1	STANDBY_DISABLE	R/W	0h	When high, standby mode is disabled and the device will immediately enter active mode with all lanes enabled when not in power down. When low, the device will enter standby mode when exiting power down and wait for incoming data before entering active mode. 0h = Standby mode enabled 1h = Standby mode disabled
0	PD_EN	R/W	1h	I2C power down. Software should clear this field after it has completed initialization. HPD_OUT will be asserted low when this field is set. 0h = Normal operation 1h = Forced power down by I2C

8.6.1.3 MISC_CONTROL Register (Offset = Ah) [Reset = 08h]

MISC_CONTROL is shown in [MISC_CONTROL Register Field Descriptions](#).

Return to the [TDP0604 Registers](#).

表 8-23. MISC_CONTROL Register Field Descriptions

Bit	Field	Type	Reset	Description
7	LANE_SWAP	R/W	0h	This field swaps the input and output lanes. 0h = No lanes swapped 1h = Both input and output lanes swapped
6	RESERVED	R/W	0h	Reserved
5	RX_TERM_DISABLE	R/W	0h	When set will disable Rx termination. 0h = Enabled when HPD_IN high. 1h = Disable
4	HPD_OUT_SEL	R/W	0h	Selects whether HPD_OUT is push/pull or open-drain. 0h = Push Pull 1h = Open Drain
3	RESERVED	R/W	1h	Reserved
2	RATE_SNOOP_CTRL	R/W	0h	Control snooping of HDMI rates. When snooping is disabled, correct HDMI rate must be written through I2C to register 20h. 0h = Snooping enabled 1h = Snooping disabled
1-0	RESERVED	R/W	0h	Reserved

8.6.1.4 GBL_SLEW_CTRL Register (Offset = Bh) [Reset = 34h]

GBL_SLEW_CTRL is shown in [GBL_SLEW_CTRL Register Field Descriptions](#).

Return to the [TDP0604 Registers](#).

表 8-24. GBL_SLEW_CTRL Register Field Descriptions

Bit	Field	Type	Reset	Description
7	RESERVED	R	0h	Reserved
6-4	SLEW_3G	R/W	3h	Field controls slew rate for HDMI 1.4 data lane. 0h = slowest edge rate 7h = fastest edge rate
3	RESERVED	R	0h	Reserved
2-0	SLEW_6G	R/W	4h	Field controls slew rate for HDMI 2.0 data lanes. 0h = slowest edge rate 7h = fastest edge rate

8.6.1.5 GBL_SLEW_CTRL2 Register (Offset = Ch) [Reset = 71h]

GBL_SLEW_CTRL2 is shown in [GBL_SLEW_CTRL2 Register Field Descriptions](#).

Return to the [TDP0604 Registers](#).

表 8-25. GBL_SLEW_CTRL2 Register Field Descriptions

Bit	Field	Type	Reset	Description
7	RESERVED	R	0h	Reserved
6-4	RESERVED	R/W	7h	Reserved
3	RESERVED	R	0h	Reserved
2-0	SLEW_CLK	R/W	1h	Field control slew rate of clock lane. 0h = slowest edge rate 7h = fastest edge rate

8.6.1.6 GBL_CTRL1 Register (Offset = Dh) [Reset = 22h]

GBL_CTRL1 is shown in [GBL_CTRL1 Register Field Descriptions](#).

Return to the [TDP0604 Registers](#).

表 8-26. GBL_CTRL1 Register Field Descriptions

Bit	Field	Type	Reset	Description
7	GLOBAL_LINR_EN	R/W	0h	Global control for selecting between linear redriver or limited redriver. 0h = Limited 1h = Linear
6	TX_AC_EN	R/W	0h	Controls selection of AC-coupled or DC-coupled TX termination. When AC-coupled is enabled, 50 Ω termination on both P and N to VCC will be enabled. 0h = DC-coupled 1h = AC-coupled
5-4	GLOBAL_DCG	R/W	2h	CTLE DCGain for all lane. 0h = -3 dB 1h = -3 dB 2h = 0 dB 3h = +1 dB
3	TXTERM_AUTO_HDMI14	R/W	0h	Selects between no termination and 300 Ω s when TERM = 2h and operating in HDMI1.4. 0h = No termination for clock less than or equal to 165 MHz and 300 Ω for clock greater than 225 MHz 1h = 300 Ω

表 8-26. GBL_CTRL1 Register Field Descriptions (continued)

Bit	Field	Type	Reset	Description
2	CTLEBYP_EN	R/W	0h	Selects whether or not CTLE bypass is enabled or not when GLOBAL_DCG is set to 2h and EQ set to 0h. 0h = CTLE bypass disabled 1h = CTLE bypass enabled
1-0	TERM	R/W	2h	TX terminaion control 0h = No termination 1h = 300 Ω 2h = Automatic based HDMI mode 3h = 100 Ω

8.6.1.7 GBL_CTLE_CTRL Register (Offset = Eh) [Reset = 3Fh]

GBL_CTLE_CTRL is shown in [GBL_CTLE_CTRL Register Field Descriptions](#).

Return to the [TDP0604 Registers](#).

表 8-27. GBL_CTLE_CTRL Register Field Descriptions

Bit	Field	Type	Reset	Description
7-6	RESERVED	R/W	0h	Reserved
5-4	HDMI14_CTLE_SEL	R/W	3h	Selects the CTLE used when datarate is HDMI 1.4. Value programmed into this field will apply to data lanes only. Clock lane will always use 3Gbps CTLE. 0h = 3 Gbps CTLE 1h = 6 Gbps CTLE 2h = Auto select based on snoop datarate 3h = Reserved
3-2	HDMI20_CTLE_SEL	R/W	3h	Selects the CTLE used when datarate is HDMI 2.0. Value programmed into this field will apply to data lanes only. Clock lane will always use 3Gbps CTLE. 0h = 3 Gbps CTLE 1h = 6 Gbps CTLE 2h = Auto select based on snoop datarate 3h = Reserved
1-0	RESERVED	R/W	3h	Reserved

8.6.1.8 DDC_CFG Register (Offset = 10h) [Reset = 02h]

DDC_CFG is shown in [DDC_CFG Register Field Descriptions](#).

Return to the [TDP0604 Registers](#).

表 8-28. DDC_CFG Register Field Descriptions

Bit	Field	Type	Reset	Description
7-2	RESERVED	R	0h	Reserved
1	DDC_LV_DCC_EN	R/W	1h	Controls whether duty cycle correction is enabled for DDC LV side. 0h = DCC disabled 1h = DCC enabled
0	DDCBUF_EN	R/W	0h	Controls whether or not DDC buffer is enabled. Regardless of the state of this field, the device will always disable the DDC buffer anytime HPD_IN is low or when PD_EN field is 1. 0h = DDC Buffer Disabled 1h = DDC Buffer Enabled

8.6.1.9 LANE_ENABLE Register (Offset = 11h) [Reset = 5Fh]

LANE_ENABLE is shown in [LANE_ENABLE Register Field Descriptions](#).

Return to the [TDP0604 Registers](#).

表 8-29. LANE_ENABLE Register Field Descriptions

Bit	Field	Type	Reset	Description
7-6	HDMI20_VOD	R/W	1h	VOD control for limited redriver in HDMI 2.0 0h = Use values in CLK_VOD, D0_VOD, D1_VOD and D2_VOD 1h = Default (1000 mV) 2h = Default - 5% 3h = Default + 5%
5-4	HDMI14_VOD	R/W	1h	VOD control for limited redriver in HDMI 1.4 0h = Use values in CLK_VOD, D0_VOD, D1_VOD and D2_VOD 1h = Default (1000 mV) 2h = Default - 5% 3h = Default - 10%
3	CLK_LANE_EN	R/W	1h	Enable for CLK lane 0h = Disabled 1h = Enabled
2	D0_LANE_EN	R/W	1h	Enable for D0 lane 0h = Disabled 1h = Enabled
1	D1_LANE_EN	R/W	1h	Enable for D0 lane 0h = Disabled 1h = Enabled
0	D2_LANE_EN	R/W	1h	Enable for D0 lane 0h = Disabled 1h = Enabled

8.6.1.10 CLK_CONFIG1 Register (Offset = 12h) [Reset = 03h]

CLK_CONFIG1 is shown in [CLK_CONFIG1 Register Field Descriptions](#).

Return to the [TDP0604 Registers](#).

表 8-30. CLK_CONFIG1 Register Field Descriptions

Bit	Field	Type	Reset	Description
7	RESERVED	R	0h	Reserved
6-4	RESERVED	R/W	0h	Reserved
3	RESERVED	R	0h	Reserved
2-0	CLK_VOD	R/W	3h	Differential Swing control for CLK lane. 0h = Limited -15% Linear 800 mV 1h = Limited -10% Linear 900 mV 2h = Limited - 5% Linear 1000 mV 3h = Limited 800 mV Linear 1200 mV 4h = Limited +5% Linear Reserved 5h = Limited +10% Linear Reserved 6h = Limited +15% Linear Reserved 7h = Limited +20% Linear Reserved

8.6.1.11 D0_CONFIG1 Register (Offset = 14h) [Reset = 03h]

D0_CONFIG1 is shown in [D0_CONFIG1 Register Field Descriptions](#).

Return to the [TDP0604 Registers](#).

表 8-31. D0_CONFIG1 Register Field Descriptions

Bit	Field	Type	Reset	Description
7	RESERVED	R	0h	Reserved
6-4	D0_TXFFE	R/W	0h	TXFFE control for D0 lane. 0h = 0.0 dB 1h = 3.5 dB 2h = 6.0 dB 3h = Reserved 4h = -1.5 dB 5h = -2.5 dB 6h = -3.5 dB 7h = -4.8 dB
3	RESERVED	R	0h	Reserved
2-0	D0_VOD	R/W	3h	Differential Swing control for D0 lane. 0h = Limited -15% Linear 800 mV 1h = Limited -10% Linear 900 mV 2h = Limited -5% Linear 1000 mV 3h = Limited 1000 mV Linear 1200 mV 4h = Limited +5% Linear Reserved 5h = Limited +10% Linear Reserved 6h = Limited +15% Linear Reserved 7h = Limited +20% Linear Reserved

8.6.1.12 D0_CONFIG2 Register (Offset = 15h) [Reset = 00h]

D0_CONFIG2 is shown in [D0_CONFIG2 Register Field Descriptions](#).

Return to the [TDP0604 Registers](#).

表 8-32. D0_CONFIG2 Register Field Descriptions

Bit	Field	Type	Reset	Description
7-4	RESERVED	R	0h	Reserved
3-0	D0_EQ	R/W	0h	EQ control for D0 lane. 0h = Min EQ Fh = Max EQ

8.6.1.13 D1_CONFIG1 Register (Offset = 16h) [Reset = 03h]

D1_CONFIG1 is shown in [D1_CONFIG1 Register Field Descriptions](#).

Return to the [TDP0604 Registers](#).

表 8-33. D1_CONFIG1 Register Field Descriptions

Bit	Field	Type	Reset	Description
7	RESERVED	R	0h	Reserved

表 8-33. D1_CONFIG1 Register Field Descriptions (continued)

Bit	Field	Type	Reset	Description
6-4	D1_TXFFE	R/W	0h	TXFFE control for D1 lane. 0h = 0.0 dB 1h = 3.5 dB 2h = 6.0 dB 3h = Reserved 4h = -1.5 dB 5h = -2.5 dB 6h = -3.5 dB 7h = -4.8 dB
3	RESERVED	R	0h	Reserved
2-0	D1_VOD	R/W	3h	Differential Swing control for D1 lane. 0h = Limited -15% Linear 800 mV 1h = Limited -10% Linear 900 mV 2h = Limited -5% Linear 1000 mV 3h = Limited 1000 mV Linear 1200 mV 4h = Limited +5% Linear Reserved 5h = Limited +10% Linear Reserved 6h = Limited +15% Linear Reserved 7h = Limited +20% Linear Reserved

8.6.1.14 D1_CONFIG2 Register (Offset = 17h) [Reset = 00h]

D1_CONFIG2 is shown in [D1_CONFIG2 Register Field Descriptions](#).

Return to the [TDP0604 Registers](#).

表 8-34. D1_CONFIG2 Register Field Descriptions

Bit	Field	Type	Reset	Description
7-4	RESERVED	R	0h	Reserved
3-0	D1_EQ	R/W	0h	EQ control for D1 lane 0h = Min EQ Fh = Max EQ

8.6.1.15 D2_CONFIG1 Register (Offset = 18h) [Reset = 03h]

D2_CONFIG1 is shown in [D2_CONFIG1 Register Field Descriptions](#).

Return to the [TDP0604 Registers](#).

表 8-35. D2_CONFIG1 Register Field Descriptions

Bit	Field	Type	Reset	Description
7	RESERVED	R	0h	Reserved
6-4	D2_TXFFE	R/W	0h	TXFFE control for D2 lane 0h = 0.0 dB 1h = 3.5 dB 2h = 6.0 dB 3h = Reserved 4h = -1.5 dB 5h = -2.5 dB 6h = -3.5 dB 7h = -4.8 dB
3	RESERVED	R	0h	Reserved

表 8-35. D2_CONFIG1 Register Field Descriptions (continued)

Bit	Field	Type	Reset	Description
2-0	D2_VOD	R/W	3h	Differential Swing control for D2 lane. 0h = Limited -15% Linear 800 mV 1h = Limited -10% Linear 900 mV 2h = Limited -5% Linear 1000 mV 3h = Limited 1000 mV Linear 1200 mV 4h = Limited +5% Linear Reserved 5h = Limited +10% Linear Reserved 6h = Limited +15% Linear Reserved 7h = Limited +20% Linear Reserved

8.6.1.16 D2_CONFIG2 Register (Offset = 19h) [Reset = 00h]

D2_CONFIG2 is shown in [D2_CONFIG2 Register Field Descriptions](#).

Return to the [TDP0604 Registers](#).

表 8-36. D2_CONFIG2 Register Field Descriptions

Bit	Field	Type	Reset	Description
7-4	RESERVED	R	0h	Reserved
3-0	D2_EQ	R/W	0h	EQ control for D2 lane. 0h = Min EQ Fh = Max EQ

8.6.1.17 SIGDET_TH_CFG Register (Offset = 1Ah) [Reset = 44h]

SIGDET_TH_CFG is shown in [SIGDET_TH_CFG Register Field Descriptions](#).

Return to the [TDP0604 Registers](#).

表 8-37. SIGDET_TH_CFG Register Field Descriptions

Bit	Field	Type	Reset	Description
7	RESERVED	R	0h	Reserved
6-4	CFG_SIGDET_HYST	R/W	4h	Controls the SIGDET hysteresis. Value programmed into this field plus value programmed into CFG_SIGDET_VTH field defines the SIGDET assert threshold. 0h = 0 mV 1h = 12 mV 2h = 25 mV 3h = 37 mV 4h = 55 mV 5h = 63 mV 6h = 75 mV 7h = 90 mV
3	RESERVED	R	0h	Reserved

表 8-37. SIGDET_TH_CFG Register Field Descriptions (continued)

Bit	Field	Type	Reset	Description
2-0	CFG_SIGDET_VTH	R/W	4h	Controls the SIGDET de-assert voltage threshold. 0h = 58 mV 1h = 60 mV 2h = 72 mV 3h = 84 mV 4h = 95 mV 5h = 108 mV 6h = 120 mV 7h = 135 mV

8.6.1.18 GBL_STATUS Register (Offset = 1Ch) [Reset = 00h]

GBL_STATUS is shown in [GBL_STATUS Register Field Descriptions](#).

Return to the [TDP0604 Registers](#).

表 8-38. GBL_STATUS Register Field Descriptions

Bit	Field	Type	Reset	Description
7	PD_STATUS	RH	0h	Power Down status
6	STANDBY_STATUS	RH	0h	Standby Status
5-0	RESERVED	R	0h	Reserved

8.6.1.19 SCDC_TMDS_CONFIG Register (Offset = 20h) [Reset = 00h]

SCDC_TMDS_CONFIG is shown in [SCDC_TMDS_CONFIG Register Field Descriptions](#).

Return to the [TDP0604 Registers](#).

表 8-39. SCDC_TMDS_CONFIG Register Field Descriptions

Bit	Field	Type	Reset	Description
7-2	RESERVED	R	0h	Reserved
1	TMDS_CLK_RATIO	RH/W	0h	TMDS Bit Period to TMDS Clock Period Ratio. Reads last value snooped through DDC read/write or I2C write. 0h = 1/10 (HDMI 1.4b) 1h = 1/40 (HDMI 2.0)
0	RESERVED	R	0h	Reserved

9 Application and Implementation

备注

以下应用部分中的信息不属于 TI 器件规格的范围，TI 不担保其准确性和完整性。TI 的客户应负责确定器件是否适用于其应用。客户应验证并测试其设计，以确保系统功能。

TDP0604 is designed to accept AC or DC-coupled HDMI input signals. The device provides signal conditioning and level shifting functions to drive a compliant HDMI source connector. The device can be used in a HDMI sink application such as monitor or TV. In many major PC or gaming systems APU/GPU will provide AC-coupled HDMI signals. TDP0604 is suitable for such platforms.

9.1 Application Information

The TDP0604 is defined to work in source applications such as Blu-ray™ DVD player, gaming system, desktop, notebook, or AVR and it is also designed to work in sink applications such as TV or monitor. The following sections provide design considerations for various types of applications.

9.2 Typical Source-Side Application

图 9-1 provides a schematic representation of what is considered a standard source implementation.



图 9-1. TDP0604 in Source Side Application

9.2.1 Design Requirements

The TDP0604 can be designed into many different applications. In all the applications there are certain requirements for the system to work properly. The EN pin must have a 0.1- μ F capacitor to ground. This pin can be driven by a processor but the pin needs to change states (low to high) after voltage rails have stabilized. The best way to configure the device is by using I²C, but pin strapping is also provided as I²C is not available in all cases. As sources may have many different naming conventions it is necessary to confirm that the link between the source and the TDP0604 are correctly mapped. A Swap function is provide for the input pins in case signaling is reversed between the source and receptacle. 表 9-1 provides information on the expected values to perform properly.

For this design example, the TDP0604 is assumed to be configured for pin-strap mode. If I2C mode is desired, MODE pin should be set to "F" and software must configure TDP0604. For information about how to configure TDP0604, refer to 节 8.5.1.

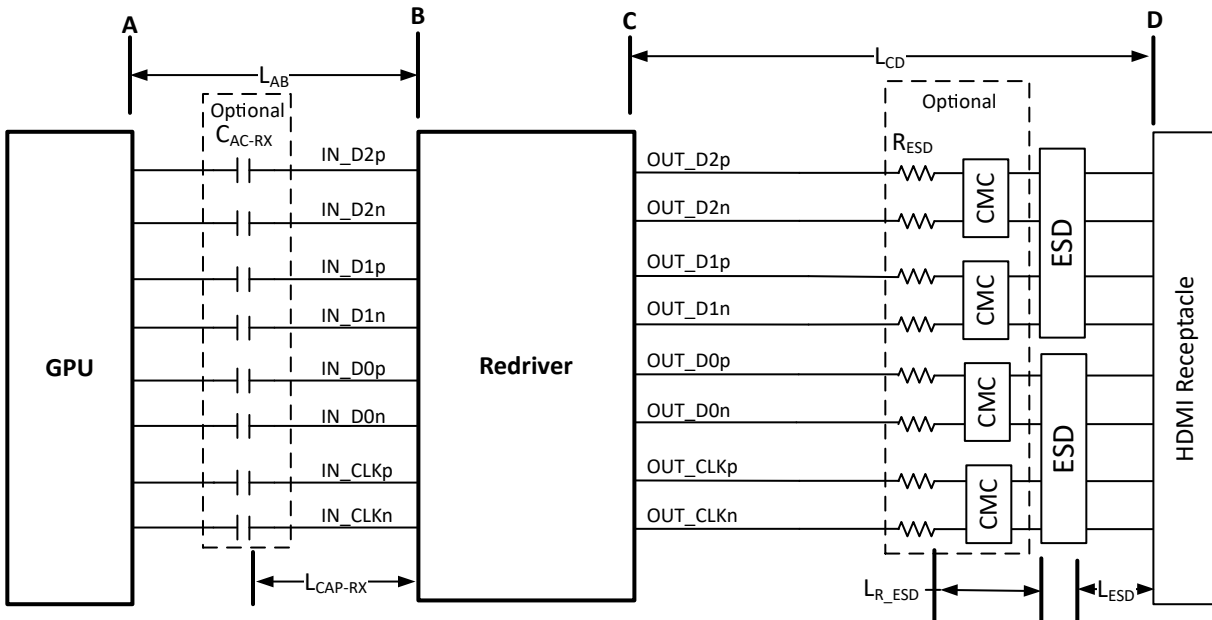
表 9-1. Design Parameters

Design Parameter	Value
V _{CC}	3.3-V
V _{IO} (1.2-V, 1.8-V, or 3.3-V LVCMOS levels)	1.8-V
Maximum HDMI Datarate (3 or 6Gbps)	6 Gbps
Pin-strap or I2C mode (if I2C, then MODE = "F").	Pin-strap
Pin Strap Mode. (MODE = "0" or "R").	Mode = "0" (Fixed EQ with DDC Buffer support)
DDC Snoop Feature. (Y/N). Required when in pin strap. Optional in I2C mode.	Yes
SWAP function (Y/N). In pin strap mode controlled by SDA/CFG1 pin.	No. SDA/CFG1 pin = L.
DDC Level Shifter Support (Y/N)	Yes
HPD_IN to HPD_OUT Level Shifter Support (Y/N)	Yes, HPD_OUT is used. If no, then HPD_OUT can be left floating.
Pre-Channel Length (Refer to 表 9-2 on length restrictions)	Length = 16 inches (\approx 10 dB at 3 GHz insertion loss)
Post-Channel Length (Refer to 表 9-2 on length restrictions)	Length = 2 inches (\approx 1.5 dB at 3 GHz insertion loss)
Limited or linear redriver mode?	Limited redriver (LINEAR_EN pin = "0").
TX is DC or AC coupled to HDMI receptacle?	DC-coupled. AC_EN pin = Low.
GPU Launch Voltage (500 to 1200 mVpp) if using limited redriver mode.	800 mVpp
CTLE HDMI Datarate Map (Map B or Map C)	Map B
RX EQ (16 possible values. Value chosen based on pre-channel length).	EQ1 pin: "F" ADDR/EQ0 pin: "F"
TX Pre-emphasis. In pre-strap mode controlled by TXPRE pin.	Default 0 dB of pre-emphasis. Float TXPRE pin.
TX Swing. In pre-strap mode controlled by TXSWG pin.	Default TX swing level. Float TXSWG pin.

表 9-2. Source Layout and Component Placement Constraints

Symbol	Parameter	Condition	Min	Typ	Max	Units
R_{ESD}	External series resistor between ESD component and TDP0604		0		2.5	Ω
L_{AB} ^{(1) (2)}	PCB trace length from GPU to TDP0604	At 6-Gbps	1		16	inches
L_{CD} ⁽¹⁾	PCB trace length from TDP0604 to receptacle	At 6-Gbps	0.75		2	inches
L_{CAP-RX}	PCB trace length from TDP0604 to optional external C_{AC-RX} capacitor		0.3			inches
L_{ESD}	PCB trace length from ESD component to receptacle				0.5	inches
L_{R_ESD}	PCB trace length from R_{ESD} to ESD component				0.25	inches
$L_{INTER-PAIR}$ ⁽³⁾	Inter-pair skew between all four channels (D0, D1, D2, and CLK)				1	inches
IL_{PCB}	PCB trace insertion loss		0.1		0.2	dB / inch / GHz
Z_{PCB_AB}	Differential impedance of L_{AB}		75		110	Ω
Z_{PCB_CD}	Differential impedance of L_{CD}		90		110	Ω
VIA_{AB}	Number of vias between GPU and TDP0604				2	VIA
VIA_{CD}	Number of vias between HDMI connector and TDP0604				1	VIA
XTALK	Differential crosstalk between adjacent differential pairs on PCB.	≤ 3 GHz			-24	dB

- (1) Maximum distance assumes PCB trace insertion loss meets IL_{PCB} requirement. If PCB trace insertion loss exceeds the maximum limit, then distance needs be reduced.
- (2) Minimum distance assumes PCB trace insertion loss meets IL_{PCB} requirement. If PCB trace insertion loss is less than the minimum limit, then distance needs to be increased.
- (3) Calculation of channel length is the sum of L_{AB} and L_{CD} .

9.2.2 Detailed Design Procedure



图 9-2. TDP0604 in Source Application Schematics

9.2.2.1 Pre-Channel (L_{AB})

The TDP0604 can support up to 12 dB at 3 GHz of insertion loss. The loss profile between the GPU/chipset and the TDP0604 input, referred to the pre-channel as depicted in 图 9-1, is less than the TDP0604 maximum receiver equalization. The loss profile of FR4 trace at different lengths is detailed in Application Curves section. The TDP0604 EQ0 and EQ1 pins should be configured to match the pre-channel insertion loss. Refer to 表 8-5 for EQ0 and EQ1 configuration options.

The GPU/chipset transmitter differential output voltage swing must be large enough so that the TDP0604s $V_{ID(DC)}$ and $V_{ID(EYE)}$ requirements are met. The $V_{ID(EYE)}$ is the eye height after the contribution of the ISI jitter only. Because a redriver can only compensate for ISI jitter, all non-ISI sources of jitter (random, sinusoidal, and so forth) will be passed through TDP0604. If the system designer requires the worst case channel length of 16 inches, then the GPU/chipset transmitter differential voltage swing without de-emphasis should be at least 1000 mVpp in order to meet the $V_{ID(DC)}$ and $V_{ID(EYE)}$ requirements of the TDP0604. A GPU/chipset transmitter which incorporates de-emphasis can meet the requirement with less than 1000 mVpp.

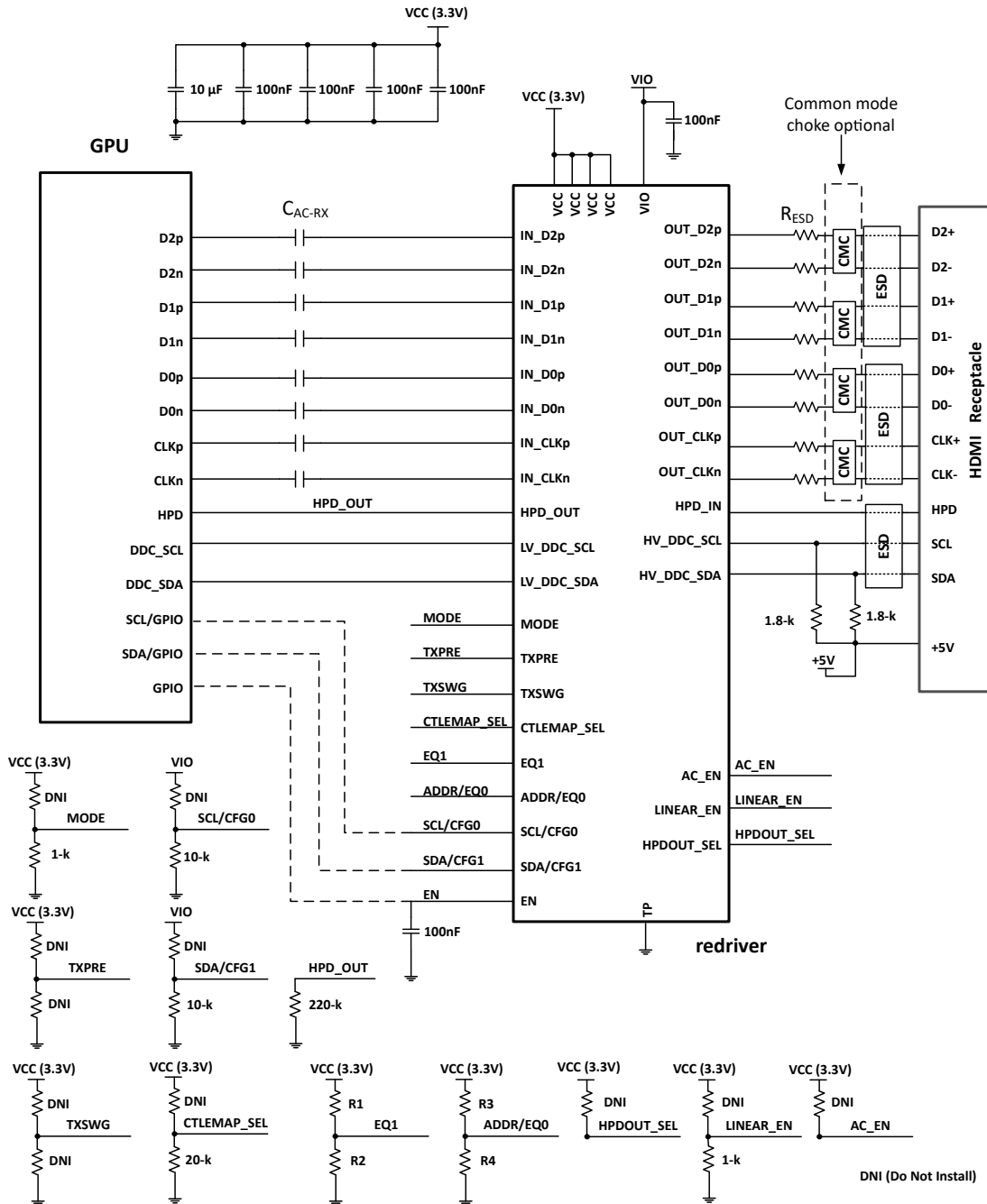
9.2.2.2 Post-Channel (L_{CD})

The post-channel, as depicted in 图 9-1, should be 2 inches or less. If ESD devices are used, then it may be necessary to overcome the insertion loss of the ESD device by increasing the TDP0604 transmitter voltage swing. This is done by configuring the TXSWG pin to the appropriate value as detailed in 表 8-12.

The post-channel is greater than 2 inches, then transmitter pre-emphasis may need to be employed. This is done by configuring the TDP0604 TXPRE pin to the appropriate setting as detailed in 表 8-11. Adjusting the TDP0604 transmitter voltage swing may also be necessary.

9.2.2.3 Common Mode Choke

It may be necessary to incorporate a common mode choke (CMC) to reduce EMI. The purpose of a CMC is to have a minimal impact to the differential signal while attenuating common mode noise thereby reducing radiated emissions. The CMC should be placed between the TDP0604 and the ESD device.

表 9-3. Recommended Common Mode Chokes

Manufacturer	Part Number
Murata	DLW21SN900HQ2
Murata	DLP11SA900HL2

9.2.2.4 ESD Protection

It may be necessary to incorporate an ESD component to protect the TDP0604 from electrostatic discharge (ESD). It is recommended that the ESD protection component has a breakdown voltage of ≥ 4.5 V and a clamp voltage of ≤ 4.3 V. A clamp voltage greater than 4.3 V will require a R_{ESD} on each high-speed differential pin. The ESD component should be placed near the HDMI connector.

表 9-4. Recommended ESD Protection Component

Manufacturer	Part Number
NXP	PUSB3FR4

9.2.3 Application Curves



图 9-3. FR4 Trace Insertion Loss at 3 GHz



图 9-4. Pre-Channel Insertion Loss at TTP2

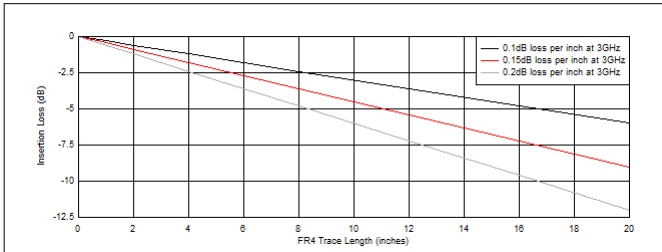

图 9-5. Post-Channel Insertion Loss at TTP4

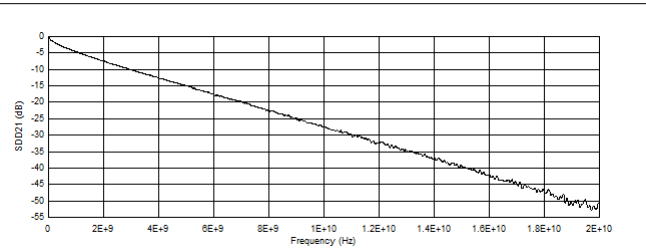

图 9-6. 2.97 Gbps Input Eye at TTP2 After Pre-Channel

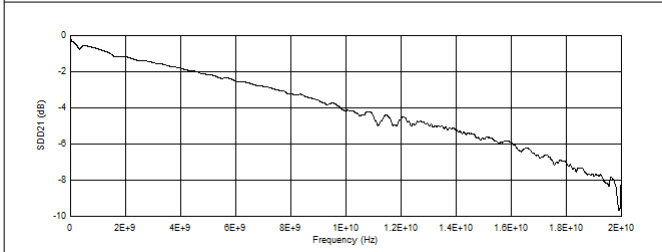

Map B, EQ6

图 9-7. 2.97 Gbps Output Eye at TTP4 After Pre and Post Channels

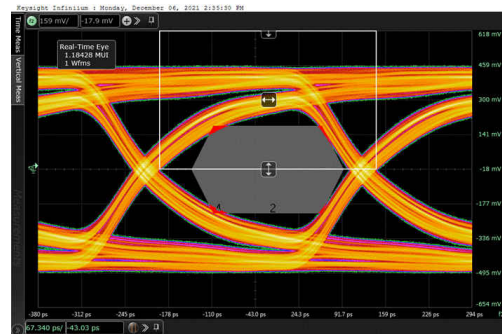
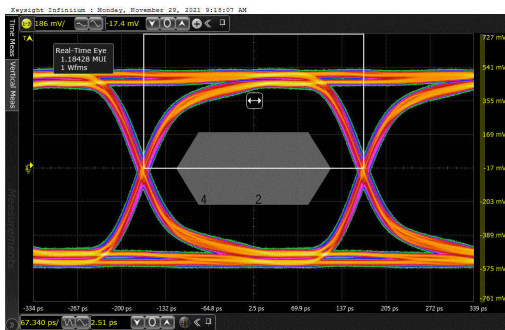

图 9-8. 5.94 Gbps Input Eye at TTP2 After Pre-Channel



Map B EQ 6

图 9-9. 5.94 Gbps Output Eye at TTP4 After Pre and Post Channels

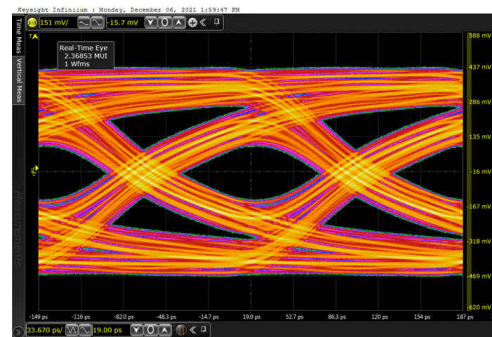
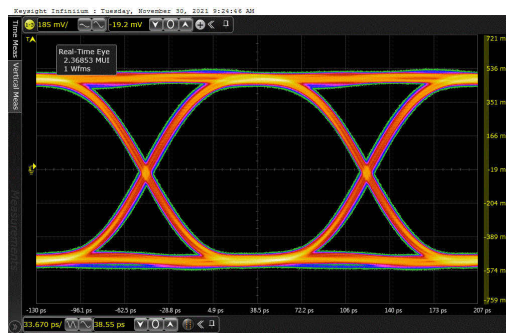
10 Power Supply Recommendations

10.1 Supply Decoupling

Texas Instruments recommends a single bulk capacitor of 10 μF on the V_{CC} supply. Along with the bulk capacitor, Texas Instruments recommends a 0.1 μF decoupling capacitor on each TDP0604 V_{CC} pin that is placed as close to the V_{CC} pin as possible. For example, see [图 9-2](#).

11 Layout

11.1 Layout Guidelines

For the TDP0604 on a high-K board, it is required to solder the PowerPAD™ onto the thermal land to ground. A thermal land is the area of solder-tinned-copper underneath the PowerPAD™ package. On a high-K board the TDP0604 can operate over the full temperature range by soldering the PowerPAD™ onto the thermal land. On a low-K board, for the device to operate across the temperature range on a low-K board, a 1-oz Cu trace connecting the GND pins to the thermal land must be used. A simulation shows $R_{\theta \text{JA}} = 30.9^\circ\text{C/W}$ allowing 950 mW power dissipation at 70°C ambient temperature. A general PCB design guide for PowerPAD packages is provided in the [PowerPAD Thermally Enhanced Package](#) application report. TI recommends using at a minimum a four layer stack up to accomplish a low-EMI PCB design. TI recommends four layers as the TDP0604 is a single voltage rail device.

- Routing the high-speed TMDS traces on the top layer avoids the use of vias (and the introduction of their inductances) and allows for clean interconnects from the HDMI connectors to the Redriver inputs and outputs. It is important to match the electrical length of these high speed traces to minimize both inter-pair and intra-pair skew.
- Placing a solid ground plane next to the high-speed single layer establishes controlled impedance for transmission link interconnects and provides an excellent low - inductance path for the return current flow.
- Placing a power plane next to the ground plane creates an additional high-frequency bypass capacitance.
- Routing slower speed control signals on the bottom layer allows for greater flexibility as these signal links usually have margin to tolerate discontinuities such as vias.
- If an additional supply voltage plane or signal layer is needed, add a second power or ground plane system to the stack to keep symmetry. This makes the stack mechanically stable and prevents it from warping. Also the power and ground plane of each power system can be placed closer together, thus increasing the high frequency bypass capacitance significantly.



图 11-1. Recommended 4 or 6-Layer PCB Stack

11.2 Layout Example

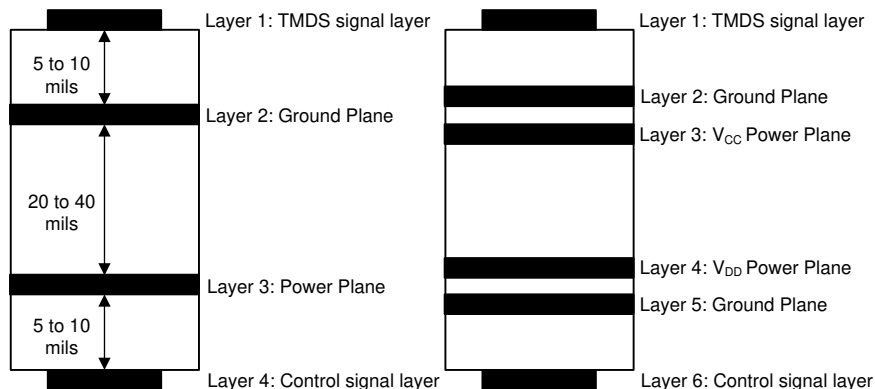

图 11-2. Source Example Layout

12 Device and Documentation Support

12.1 Documentation Support

12.1.1 Related Documentation

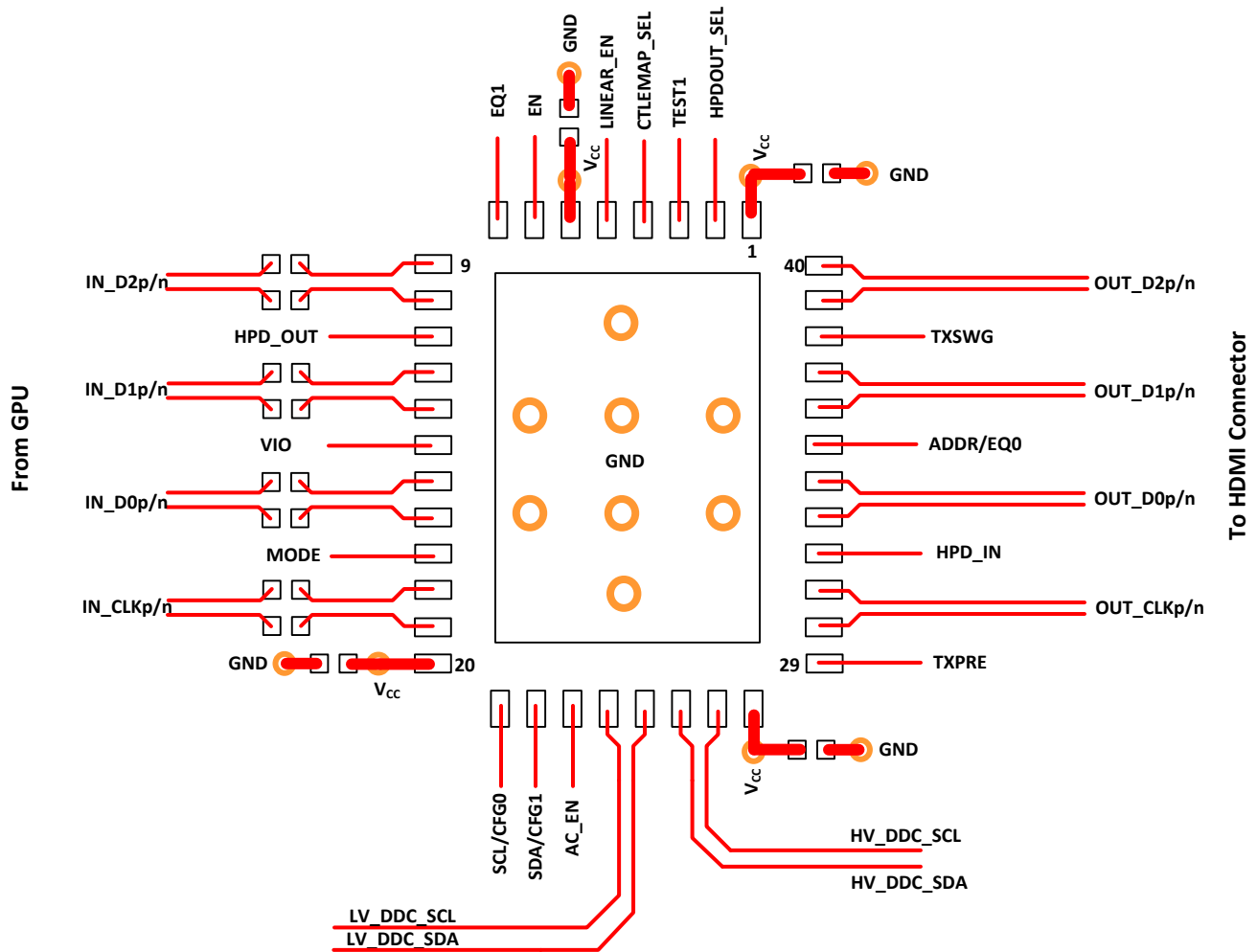
For related documentation, see the following:

- Texas Instruments, [PowerPAD Thermally Enhanced Package application report](#)

12.2 接收文档更新通知

要接收文档更新通知，请导航至 ti.com 上的器件产品文件夹。点击 [订阅更新](#) 进行注册，即可每周接收产品信息更改摘要。有关更改的详细信息，请查看任何已修订文档中包含的修订历史记录。

12.3 支持资源

TI E2E™ [支持论坛](#) 是工程师的重要参考资料，可直接从专家获得快速、经过验证的解答和设计帮助。搜索现有解答或提出自己的问题可获得所需的快速设计帮助。

链接的内容由各个贡献者“按原样”提供。这些内容并不构成 TI 技术规范，并且不一定反映 TI 的观点；请参阅 TI 的《[使用条款](#)》。

12.4 Trademarks

HDMI™ is a trademark of HDMI Licensing Administrator.

Blu-ray™ is a trademark of Blu-ray Disc Association (BDA).

PowerPAD™ and TI E2E™ are trademarks of Texas Instruments.

所有商标均为其各自所有者的财产。

12.5 Electrostatic Discharge Caution



This integrated circuit can be damaged by ESD. Texas Instruments recommends that all integrated circuits be handled with appropriate precautions. Failure to observe proper handling and installation procedures can cause damage.

ESD damage can range from subtle performance degradation to complete device failure. Precision integrated circuits may be more susceptible to damage because very small parametric changes could cause the device not to meet its published specifications.

12.6 术语表

[TI 术语表](#) 本术语表列出并解释了术语、首字母缩略词和定义。

13 Mechanical, Packaging, and Orderable Information

The following pages include mechanical, packaging, and orderable information. This information is the most current data available for the designated devices. This data is subject to change without notice and revision of this document. For browser-based versions of this data sheet, refer to the left-hand navigation.

PACKAGING INFORMATION

Orderable Device	Status (1)	Package Type	Package Drawing	Pins	Package Qty	Eco Plan (2)	Lead finish/ Ball material (6)	MSL Peak Temp (3)	Op Temp (°C)	Device Marking (4/5)	Samples
TDP0604IRNQR	ACTIVE	WQFN	RNQ	40	3000	RoHS & Green	NIPDAU	Level-2-260C-1 YEAR	-40 to 85	TDP04	Samples
TDP0604IRNQT	ACTIVE	WQFN	RNQ	40	250	RoHS & Green	NIPDAU	Level-2-260C-1 YEAR	-40 to 85	TDP04	Samples
TDP0604RNQR	ACTIVE	WQFN	RNQ	40	3000	RoHS & Green	NIPDAU	Level-2-260C-1 YEAR	0 to 85	TDP04	Samples
TDP0604RNQT	ACTIVE	WQFN	RNQ	40	250	RoHS & Green	NIPDAU	Level-2-260C-1 YEAR	0 to 85	TDP04	Samples

(1) The marketing status values are defined as follows:

ACTIVE: Product device recommended for new designs.

LIFEBUY: TI has announced that the device will be discontinued, and a lifetime-buy period is in effect.

NRND: Not recommended for new designs. Device is in production to support existing customers, but TI does not recommend using this part in a new design.

PREVIEW: Device has been announced but is not in production. Samples may or may not be available.

OBSELETE: TI has discontinued the production of the device.

(2) **RoHS:** TI defines "RoHS" to mean semiconductor products that are compliant with the current EU RoHS requirements for all 10 RoHS substances, including the requirement that RoHS substance do not exceed 0.1% by weight in homogeneous materials. Where designed to be soldered at high temperatures, "RoHS" products are suitable for use in specified lead-free processes. TI may reference these types of products as "Pb-Free".

RoHS Exempt: TI defines "RoHS Exempt" to mean products that contain lead but are compliant with EU RoHS pursuant to a specific EU RoHS exemption.

Green: TI defines "Green" to mean the content of Chlorine (Cl) and Bromine (Br) based flame retardants meet JS709B low halogen requirements of <=1000ppm threshold. Antimony trioxide based flame retardants must also meet the <=1000ppm threshold requirement.

(3) MSL, Peak Temp. - The Moisture Sensitivity Level rating according to the JEDEC industry standard classifications, and peak solder temperature.

(4) There may be additional marking, which relates to the logo, the lot trace code information, or the environmental category on the device.

(5) Multiple Device Markings will be inside parentheses. Only one Device Marking contained in parentheses and separated by a "-" will appear on a device. If a line is indented then it is a continuation of the previous line and the two combined represent the entire Device Marking for that device.

(6) Lead finish/Ball material - Orderable Devices may have multiple material finish options. Finish options are separated by a vertical ruled line. Lead finish/Ball material values may wrap to two lines if the finish value exceeds the maximum column width.

Important Information and Disclaimer:The information provided on this page represents TI's knowledge and belief as of the date that it is provided. TI bases its knowledge and belief on information provided by third parties, and makes no representation or warranty as to the accuracy of such information. Efforts are underway to better integrate information from third parties. TI has taken and

continues to take reasonable steps to provide representative and accurate information but may not have conducted destructive testing or chemical analysis on incoming materials and chemicals. TI and TI suppliers consider certain information to be proprietary, and thus CAS numbers and other limited information may not be available for release.

In no event shall TI's liability arising out of such information exceed the total purchase price of the TI part(s) at issue in this document sold by TI to Customer on an annual basis.

RNQ0040A

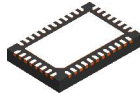

PACKAGE OUTLINE

WQFN - 0.8 mm max height

PLASTIC QUAD FLATPACK - NO LEAD

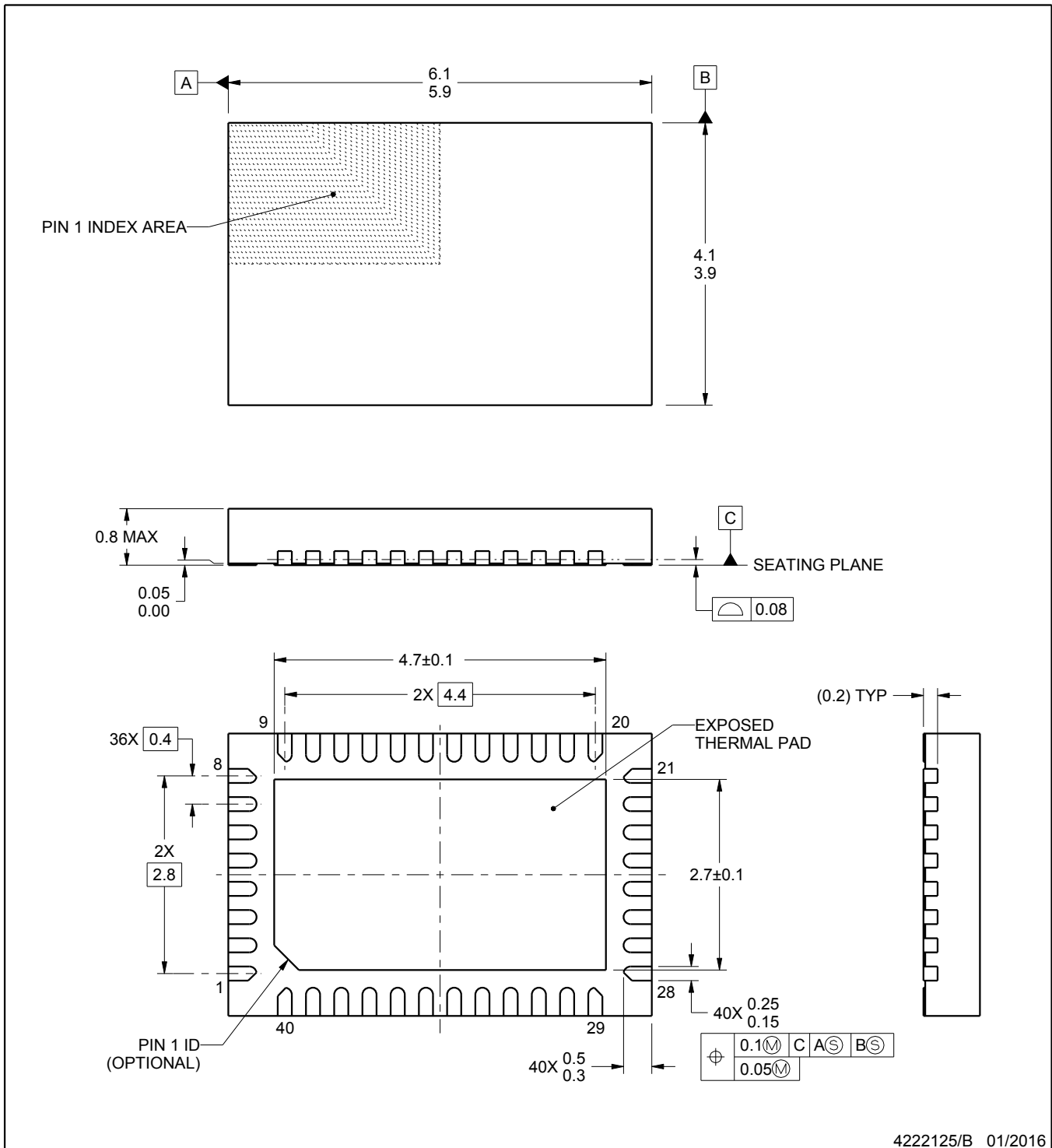

4222125/B 01/2016

NOTES:

1. All linear dimensions are in millimeters. Any dimensions in parenthesis are for reference only. Dimensioning and tolerancing per ASME Y14.5M.
2. This drawing is subject to change without notice.
3. The package thermal pad must be soldered to the printed circuit board for thermal and mechanical performance.

EXAMPLE BOARD LAYOUT

RNQ0040A

WQFN - 0.8 mm max height

PLASTIC QUAD FLATPACK - NO LEAD

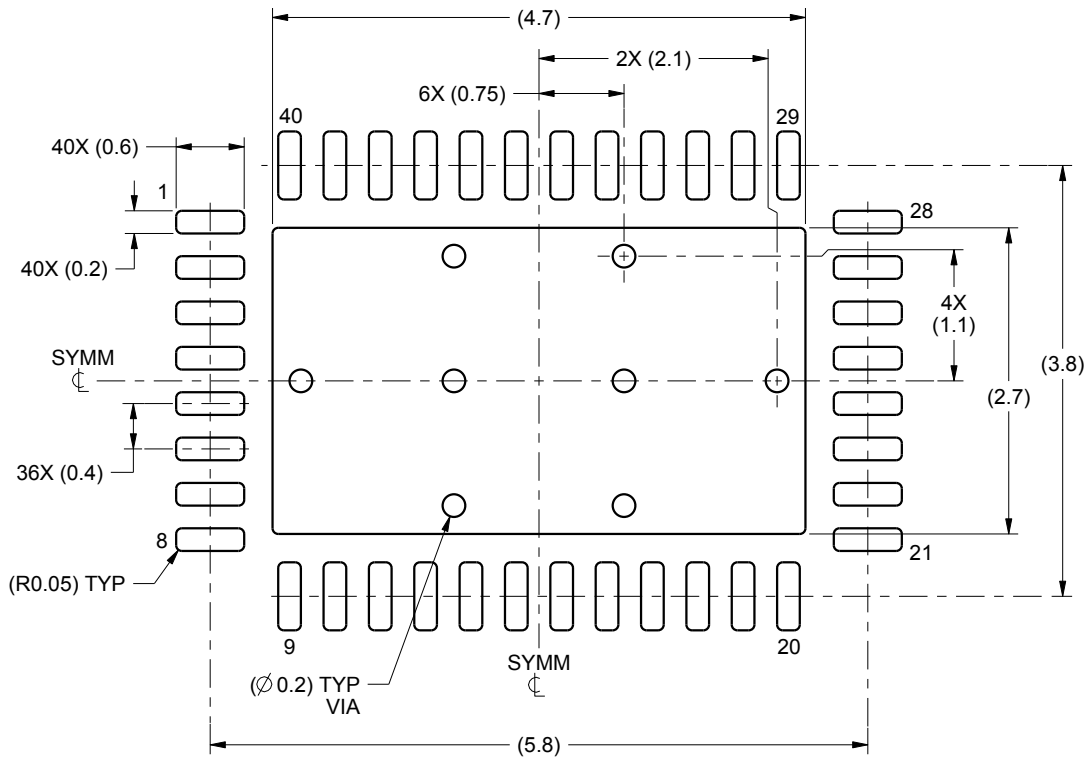

LAND PATTERN EXAMPLE
SCALE:15X

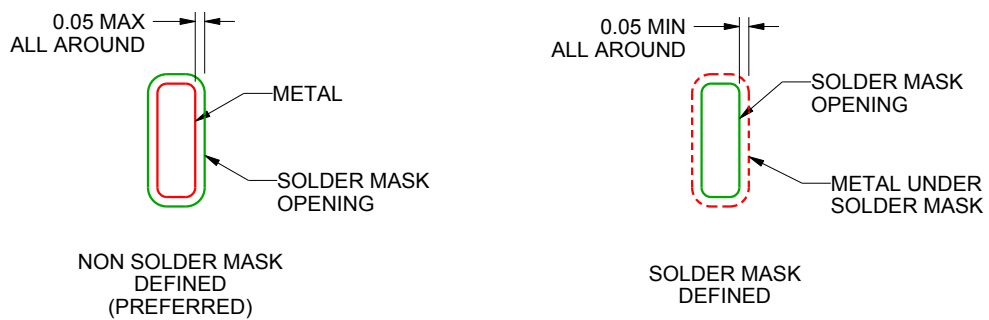

SOLDER MASK DETAILS

4222125/B 01/2016

NOTES: (continued)

4. This package is designed to be soldered to a thermal pad on the board. For more information, see Texas Instruments literature number SLUA271 (www.ti.com/lit/slua271).

EXAMPLE STENCIL DESIGN

RNQ0040A

WQFN - 0.8 mm max height

PLASTIC QUAD FLATPACK - NO LEAD

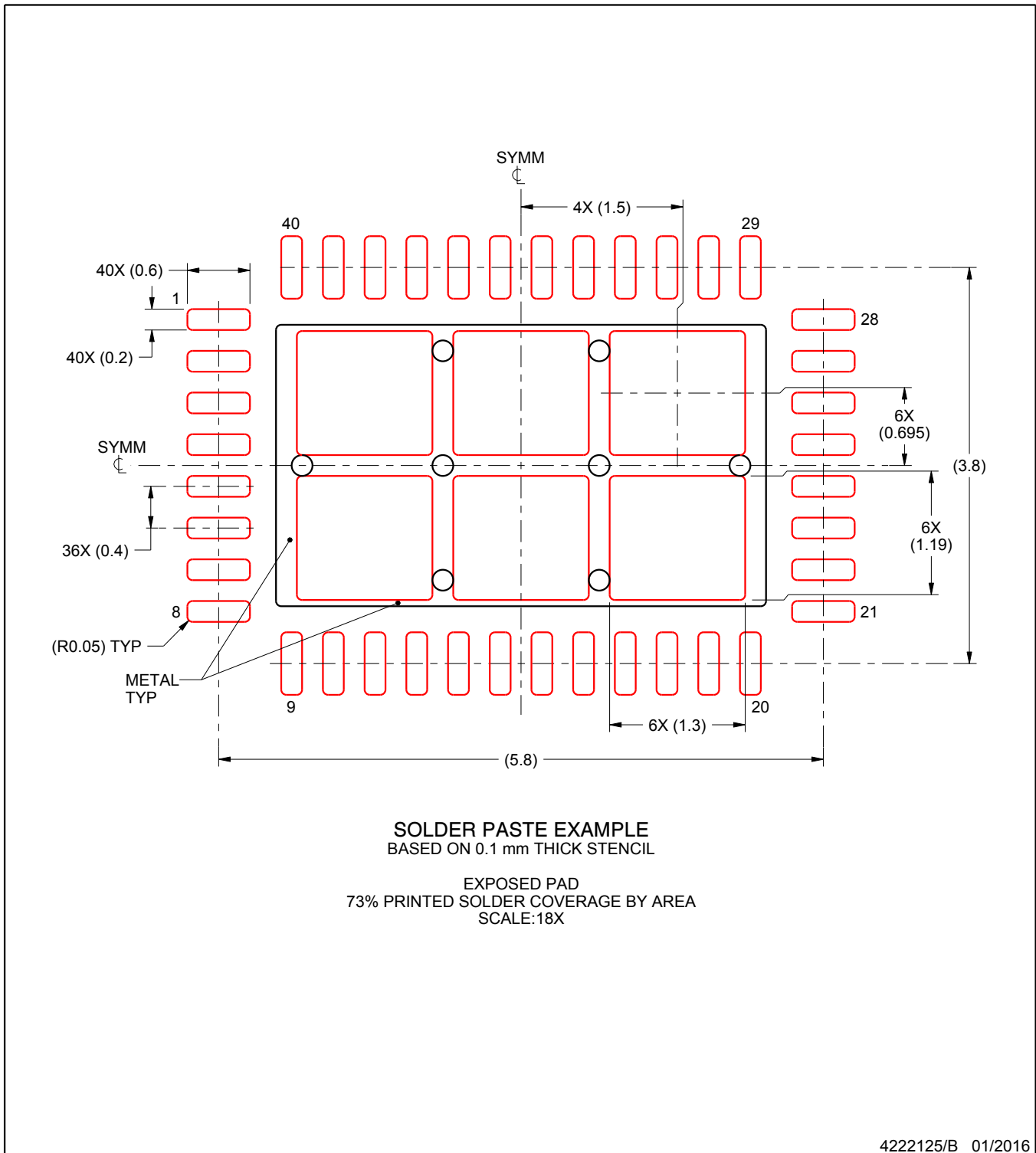

NOTES: (continued)

5. Laser cutting apertures with trapezoidal walls and rounded corners may offer better paste release. IPC-7525 may have alternate design recommendations.

重要声明和免责声明

TI“按原样”提供技术和可靠性数据（包括数据表）、设计资源（包括参考设计）、应用或其他设计建议、网络工具、安全信息和其他资源，不保证没有瑕疵且不做任何明示或暗示的担保，包括但不限于对适销性、某特定用途方面的适用性或不侵犯任何第三方知识产权的暗示担保。

这些资源可供使用 TI 产品进行设计的熟练开发人员使用。您将自行承担以下全部责任：(1) 针对您的应用选择合适的 TI 产品，(2) 设计、验证并测试您的应用，(3) 确保您的应用满足相应标准以及任何其他功能安全、信息安全、监管或其他要求。

这些资源如有变更，恕不另行通知。TI 授权您仅可将这些资源用于研发本资源所述的 TI 产品的应用。严禁对这些资源进行其他复制或展示。您无权使用任何其他 TI 知识产权或任何第三方知识产权。您应全额赔偿因在这些资源的使用中对 TI 及其代表造成的任何索赔、损害、成本、损失和债务，TI 对此概不负责。

TI 提供的产品受 [TI 的销售条款](#) 或 [ti.com](#) 上其他适用条款/TI 产品随附的其他适用条款的约束。TI 提供这些资源并不会扩展或以其他方式更改 TI 针对 TI 产品发布的适用的担保或担保免责声明。

TI 反对并拒绝您可能提出的任何其他或不同的条款。

邮寄地址：Texas Instruments, Post Office Box 655303, Dallas, Texas 75265

Copyright © 2022，德州仪器 (TI) 公司