

TL431、TL432 精密可编程基准

1 特性

- 25°C 下的基准电压容差
 - 0.5% (B 级)
 - 1% (A 级)
 - 2% (标准级)
- 可调输出电压: V_{ref} 至 36V
- 工作温度范围: -40°C 至 125°C
- 典型温度漂移 (TL43xB)
 - 6mV (C 级温度)
 - 14mV (I 级温度, Q 级温度)
- 低输出噪声
- 0.2 Ω 输出阻抗典型值
- 灌电流能力: 1mA 至 100mA

2 应用

- 可调节电压和电流基准
- 反激式开关模式电源 (SMPS) 中的次级侧调节
- 齐纳二极管替代产品
- 电压监测
- 具有集成基准的比较器

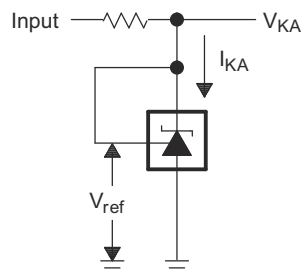

简化版原理图

3 说明

TL431LI/TL432LI 是 TL431/TL432 的引脚对引脚替代产品。TL43xLI 具有更好的稳定性、更低温漂 ($V_{I(dev)}$) 以及更低基准电流 (I_{ref})，从而提高了系统精度。

TL431 和 TL432 器件是三端可调节并联稳压器，在适用的汽车级、商用级和军用级温度范围内均可满足规定的热稳定性。可以通过两个外部电阻器将输出电压设置为介于 V_{ref} (约为

2.5V) 和 36V 之间的任意值。其输出阻抗典型值均为 0.2 Ω 。此类器件的有源输出电路具有非常明显的导通特性，因此非常适合用于替代许多应用中的齐纳二极管，例如板载稳压器、可调节电源和开关电源。TL432 器件具有与 TL431 器件完全相同的功能和电气特性，但是具有不同的 DBV、DBZ 和 PK 封装引脚排列。

TL431 和 TL432 器件都具有 B、A 和标准三个等级，25°C 下的初始容差分别为 0.5%、1% 和 2%。此外，低输出温漂可确保在整个温度范围内保持出色的稳定性。

TL43xxC 器件运行温度范围为 0°C 至 70°C，TL43xxI 器件运行温度范围为 -40°C 至 85°C，TL43xxQ 器件运行温度范围为 -40°C 至 125°C。

器件信息

器件型号 (1)	封装 (引脚)	封装尺寸 (标称值)
TL43x	SOT-23-3 (3)	2.90mm x 1.30mm
	SOT-23-5 (5)	2.90mm x 1.60mm
	SOIC (8)	4.90mm x 3.90mm
	PDIP (8)	9.50mm x 6.35mm
	SOP (8)	6.20mm x 5.30mm

(1) 如需了解所有可用封装，请参阅数据表末尾的可订购产品附录。



内容

1 特性.....	1	9.1 概述.....	21
2 应用.....	1	9.2 功能方框图.....	21
3 说明.....	1	9.3 特性说明.....	22
4 修订历史记录.....	2	9.4 器件功能模式.....	22
5 器件比较表.....	3	10 应用和实现	23
6 引脚配置和功能.....	4	10.1 应用信息.....	23
7 规格.....	6	10.2 典型应用.....	23
7.1 绝对最大额定值.....	6	10.3 系统示例.....	28
7.2 ESD 等级.....	6	11 电源相关建议	31
7.3 热性能信息.....	6	12 布局	31
7.4 建议运行条件.....	6	12.1 布局指南.....	31
7.5 电气特性, TL431C、TL432C.....	7	12.2 布局示例.....	31
7.6 电气特性, TL431I、TL432I.....	8	13 器件和文档支持	32
7.7 电气特性, TL431Q、TL432Q.....	9	13.1 器件命名规则.....	32
7.8 电气特性, TL431AC、TL432AC.....	10	13.2 相关链接.....	32
7.9 电气特性, TL431AI、TL432AI.....	11	13.3 接收文档更新通知.....	32
7.10 电气特性, TL431AQ、TL432AQ.....	12	13.4 支持资源.....	32
7.11 电气特性, TL431BC、TL432BC.....	13	13.5 商标.....	32
7.12 电气特性, TL431BI、TL432BI.....	14	13.6 Electrostatic Discharge Caution.....	32
7.13 电气特性, TL431BQ、TL432BQ.....	15	13.7 术语表.....	33
8 参数测量信息.....	20	14 机械、封装和可订购信息	33
9 详细说明.....	21		

4 修订历史记录

Changes from Revision P (November 2018) to Revision Q (July 2022)	Page
• 更新了整个文档中的表格、图和交叉引用的编号格式.....	1
• 更正了 引脚功能表 中的器件名称.....	4
Changes from Revision O (January 2015) to Revision P (November 2018)	Page
• 向 说明 部分添加了文本.....	1
• 添加了 TL43x 器件比较表	3
• 添加了 TL43x 器件命名规则 部分.....	32
Changes from Revision N (January 2014) to Revision O (January 2015)	Page
• 添加了 应用 、 器件信息表 、 引脚功能表 、 ESD 等级表 、 热性能信息表 、 特性说明 部分、 器件功能模式 、 应用和实现 部分、 电源相关建议 部分、 布局 部分、 器件和文档支持 部分以及 机械、封装和可订购信息 部分.....	1
• 添加了“应用”.....	1
• 将 典型特性 移至 规格 部分。.....	0
Changes from Revision M (July 2012) to Revision N (January 2014)	Page
• 更新了文档格式.....	1
• 删除了 订购信息表	4
• 添加了 应用手册链接	23

5 器件比较表

器件引脚分配	初始精度	自然通风条件下的工作温度 (T _A)
TL431 TL432	B : 0.5% A : 1% (空白) : 2%	C : 0°C 至 70°C I : -40°C 至 85°C Q : -40°C 至 125°C

6 引脚配置和功能

TL431, TL431A, TL431B ... LP (TO-92/TO-226) PACKAGE (TOP VIEW)

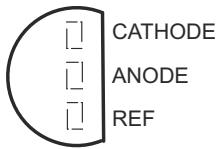

TL431 ... KTP (PowerFLEX /TO-252) PACKAGE (TOP VIEW)

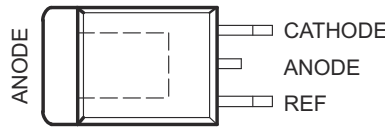

TL431A, TL431B ... DCK (SC-70) PACKAGE (TOP VIEW)

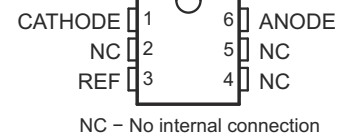

TL431, TL431A, TL431B ... D (SOIC) PACKAGE (TOP VIEW)

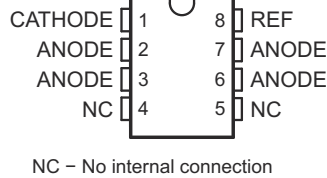

TL431, TL431A, TL431B ... P (PDIP), PS (SOP), OR PW (TSSOP) PACKAGE (TOP VIEW)

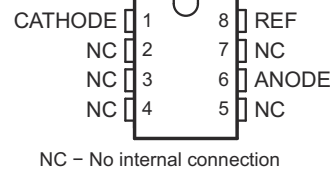

TL431, TL431A, TL431B ... PK (SOT-89) PACKAGE (TOP VIEW)

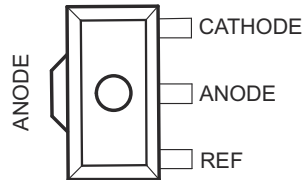

TL432, TL432A, TL432B ... PK (SOT-89) PACKAGE (TOP VIEW)

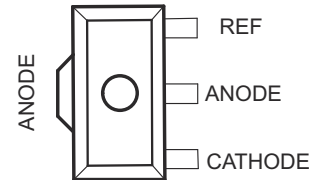

TL431, TL431A, TL431B ... DBV (SOT-23-5) PACKAGE (TOP VIEW)

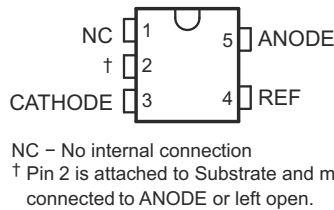

TL432, TL432A, TL432B ... DBV (SOT-23-5) PACKAGE (TOP VIEW)

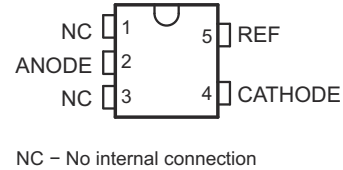

TL431, TL431A, TL431B ... DBZ (SOT-23-3) PACKAGE (TOP VIEW)

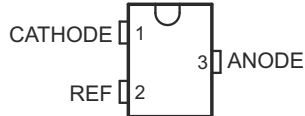

TL432, TL432A, TL432B ... DBZ (SOT-23-3) PACKAGE (TOP VIEW)



表 6-1. 引脚功能

名称	引脚											类型	说明
	TL431x							TL432x					
	DBZ	DBV	PK	D	P, PS PW	LP	KTP	DCK	DBZ	DBV	PK		
CATHODE (阴极)	1	3	3	1	1	1	1	1	2	4	1	I/O	并联电流/电压输入
REF (基准)	2	4	1	8	8	3	3	3	1	5	3	I	相对于通用阳极的阈值

表 6-1. 引脚功能 (continued)

名称	引脚											类型	说明
	TL431x								TL432x				
	DBZ	DBV	PK	D	P、PS PW	LP	KTP	DCK	DBZ	DBV	PK		
ANODE (阳极)	3	5	2	2、 3、 6、7	6	2	2	6	3	2	2	O	通用引脚，通常接地

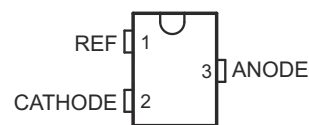
7 规格

7.1 绝对最大额定值

在自然通风条件下的工作温度范围内测得（除非另有说明）⁽¹⁾

		最小值	最大值	单位
V_{KA}	阴极电压 ⁽²⁾		37	V
I_{KA}	连续阴极电流范围	- 100	150	mA
$I_{I(ref)}$	基准输入电流范围	- 0.05	10	mA
T_J	工作等效结温		150	°C
T_{stg}	存储温度范围	-65	150	°C

- (1) 超出“绝对最大额定值”下列出的压力可能会对器件造成永久损坏。这些仅为压力额定值，并不表示器件在这些条件下以及在[建议运行条件](#)以外的任何其他条件下能够正常运行。长时间处于绝对最大额定条件下可能会影响器件的可靠性。
- (2) 除非另有说明，否则所有电压值均以 ANODE 为基准。

7.2 ESD 等级

		值	单位
$V_{(ESD)}$	静电放电		V
	人体放电模型 (HBM), 符合 ANSI/ESDA/JEDEC JS-001 标准 ⁽¹⁾	±2000	
	充电器件模型 (CDM), 符合 JEDEC 规范 JESD22-C101 ⁽²⁾	±1000	

- (1) JEDEC 文件 JEP155 指出：500V HBM 可实现在标准 ESD 控制流程下安全生产。若部署必要的预防措施，则可以在低于 500V HBM 时进行生产。
- (2) JEDEC 文档 JEP157 指出：250V CDM 能够在标准 ESD 控制流程下安全生产。若部署必要的预防措施，则可以在低于 250V CDM 时进行生产。

7.3 热性能信息

热指标 ⁽¹⁾	TL43xx									单位	
	P	PW	D	PS	DCK	DBV	DBZ	LP	PK		
	8 引脚				6 引脚	5 引脚	3 引脚				
$R_{\theta JA}$	结至环境热阻	85	149	97	95	259	206	206	140	52	°C/W
$R_{\theta JC(top)}$	结至外壳（顶部）热阻	57	65	39	46	87	131	76	55	9	

- (1) 有关新旧热指标的更多信息，请参阅 [IC 封装热指标应用报告 \(SPRA953\)](#)。

7.4 建议运行条件

请参阅⁽¹⁾

		最小值	最大值	单位
V_{KA}	阴极电压	V_{ref}	36	V
I_{KA}	阴极电流	1	100	mA
T_A	自然通风条件下的工作温度范围	TL43xxC	0	70
		TL43xxI	-40	85
		TL43xxQ	-40	125

- (1) 最大功耗是与 $T_{J(max)}$ 、 θ_{JA} 和 T_A 相关的函数。在任何允许的环境温度下，允许的最大功耗为 $P_D = (T_{J(max)} - T_A) / \theta_{JA}$ 。在 150°C 的绝对最大 T_J 下运行可能会影响可靠性。

7.5 电气特性，TL431C、TL432C

在推荐的工作条件下测得， $T_A = 25^\circ\text{C}$ (除非另有说明)

参数	测试电路	测试条件	TL431C、TL432C			单位	
			最小值	典型值	最大值		
V_{ref}	基准电压	请参阅图 8-1	$V_{KA} = V_{\text{ref}}, I_{KA} = 10\text{mA}$			mV	
$V_{I(\text{dev})}$	整个温度范围内的基准输入电压偏差 ⁽¹⁾	请参阅图 8-1	$V_{KA} = V_{\text{ref}}, I_{KA} = 10\text{mA}$,	SOT23-3 和 TL432 器件	6	16	mV
				所有其他器件	4	25	
$\Delta V_{\text{ref}} / \Delta V_{KA}$	基准电压变化与阴极电压变化之比	请参阅图 8-2	$I_{KA} = 10\text{mA}$	$\Delta V_{KA} = 10\text{V} - V_{\text{ref}}$	-1.4	-2.7	mV/V
				$\Delta V_{KA} = 36\text{V} - 10\text{V}$	-1	-2	
I_{ref}	基准输入电流	请参阅图 8-2	$I_{KA} = 10\text{mA}, R1 = 10\text{k}\Omega, R2 = \infty$			μA	
$I_{I(\text{dev})}$	整个温度范围内的基准输入电流偏差 ⁽¹⁾	请参阅图 8-2	$I_{KA} = 10\text{mA}, R1 = 10\text{k}\Omega, R2 = \infty$			μA	
I_{min}	调节的最小阴极电流	请参阅图 8-1	$V_{KA} = V_{\text{ref}}$			mA	
I_{off}	关闭状态阴极电流	请参阅图 8-3	$V_{KA} = 36\text{V}, V_{\text{ref}} = 0$			μA	
$ z_{KA} $	动态阻抗 ⁽²⁾	请参阅图 8-1	$V_{KA} = V_{\text{ref}}, f \leq 1\text{kHz}, I_{KA} = 1\text{mA}$ 至 100mA			Ω	

- (1) 偏差参数 $V_{\text{ref}(\text{dev})}$ 和 $I_{\text{ref}(\text{dev})}$ 是指在额定温度范围内获得的最大和最小值之间的差异。基准输入电压的平均全范围温度系数 $\alpha_{V_{\text{ref}}}$ 定义为：

$$|\alpha_{V_{\text{ref}}}| \left(\frac{\text{ppm}}{^\circ\text{C}} \right) = \frac{\left(\frac{V_{I(\text{dev})}}{V_{\text{ref at } 25^\circ\text{C}}} \right) \times 10^6}{\Delta T_A}$$

where:

ΔT_A is the rated operating temperature range of the device.

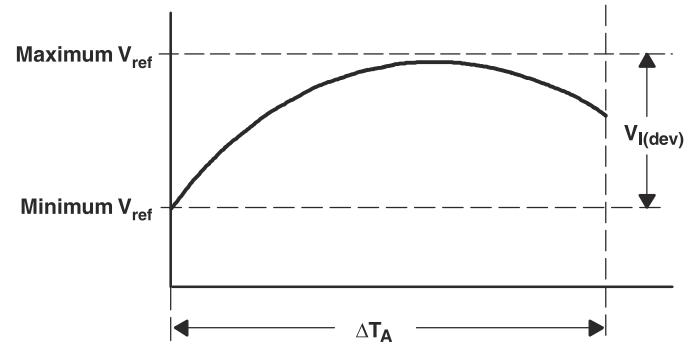

$\alpha_{V_{\text{ref}}}$ 可能是正数，也可能是负数，具体取决于较低温度条件下出现的是最小 V_{ref} 还是最大 V_{ref} 。

- (2) 动态阻抗定义为： $|z_{KA}| = \frac{\Delta V_{KA}}{\Delta I_{KA}}$

当器件在配备两个外部电阻器的情况下运行时（请参阅图 8-2），电路的总动态阻抗为： $|z'| = \frac{\Delta V}{\Delta I}$ 这约等于： $|z_{KA}| \left(1 + \frac{R1}{R2} \right)$ 。

7.6 电气特性, TL431I、TL432I

在推荐的工作条件下测得, $T_A = 25^\circ\text{C}$ (除非另有说明)

参数	测试电路	测试条件	TL431I、TL432I			单位	
			最小值	典型值	最大值		
V_{ref}	基准电压	请参阅图 8-1	$V_{\text{KA}} = V_{\text{ref}}, I_{\text{KA}} = 10\text{mA}$			mV	
$V_{\text{I(dev)}}$	整个温度范围内的基准输入电压偏差 ⁽¹⁾	请参阅图 8-1	$V_{\text{KA}} = V_{\text{ref}}, I_{\text{KA}} = 10\text{mA}$	SOT23-3 和 TL432 器件	14	34	mV
				所有其他器件	5	50	
$\Delta V_{\text{ref}} / \Delta V_{\text{KA}}$	基准电压变化与阴极电压变化之比	请参阅图 8-2	$I_{\text{KA}} = 10\text{mA}$	$\Delta V_{\text{KA}} = 10\text{V} - V_{\text{ref}}$	-1.4	-2.7	mV/V
				$\Delta V_{\text{KA}} = 36\text{V} - 10\text{V}$	-1	-2	
I_{ref}	基准输入电流	请参阅图 8-2	$I_{\text{KA}} = 10\text{mA}, R1 = 10\text{k}\Omega, R2 = \infty$			μA	
$I_{\text{I(dev)}}$	整个温度范围内的基准输入电流偏差 ⁽¹⁾	请参阅图 8-2	$I_{\text{KA}} = 10\text{mA}, R1 = 10\text{k}\Omega, R2 = \infty$			μA	
I_{min}	调节的最小阴极电流	请参阅图 8-1	$V_{\text{KA}} = V_{\text{ref}}$			mA	
I_{off}	关闭状态阴极电流	请参阅图 8-3	$V_{\text{KA}} = 36\text{V}, V_{\text{ref}} = 0$			μA	
$ z_{\text{KA}} $	动态阻抗 ⁽²⁾	请参阅图 8-1	$V_{\text{KA}} = V_{\text{ref}}, f \leq 1\text{kHz}, I_{\text{KA}} = 1\text{mA}$ 至 100mA			Ω	

7.7 电气特性，TL431Q、TL432Q

在推荐的工作条件下测得， $T_A = 25^\circ\text{C}$ (除非另有说明)

参数	测试电路	测试条件	TL431Q、TL432Q			单位	
			最小值	典型值	最大值		
V_{ref}	基准电压	请参阅图 8-1	$V_{\text{KA}} = V_{\text{ref}}, I_{\text{KA}} = 10\text{mA}$			mV	
$V_{\text{I(dev)}}$	整个温度范围内的基准输入电压偏差 ⁽¹⁾	请参阅图 8-1	$V_{\text{KA}} = V_{\text{ref}}, I_{\text{KA}} = 10\text{mA}$			mV	
$\frac{\Delta V_{\text{ref}}}{\Delta V_{\text{KA}}}$	基准电压变化与阴极电压变化之比	请参阅图 8-2	$I_{\text{KA}} = 10\text{mA}$	$\Delta V_{\text{KA}} = 10\text{V} - V_{\text{ref}}$	-1.4	-2.7	mV/V
				$\Delta V_{\text{KA}} = 36\text{V} - 10\text{V}$	-1	-2	
I_{ref}	基准输入电流	请参阅图 8-2	$I_{\text{KA}} = 10\text{mA}, R1 = 10\text{k}\Omega, R2 = \infty$			μA	
$I_{\text{I(dev)}}$	整个温度范围内的基准输入电流偏差 ⁽¹⁾	请参阅图 8-2	$I_{\text{KA}} = 10\text{mA}, R1 = 10\text{k}\Omega, R2 = \infty$			μA	
I_{min}	调节的最小阴极电流	请参阅图 8-1	$V_{\text{KA}} = V_{\text{ref}}$			mA	
I_{off}	关闭状态阴极电流	请参阅图 8-3	$V_{\text{KA}} = 36\text{V}, V_{\text{ref}} = 0$			μA	
$ z_{\text{KA}} $	动态阻抗 ⁽²⁾	请参阅图 8-1	$V_{\text{KA}} = V_{\text{ref}}, f \leq 1\text{kHz}, I_{\text{KA}} = 1\text{mA}$ 至 100mA			Ω	

7.8 电气特性，TL431AC、TL432AC

在推荐的工作条件下测得， $T_A = 25^\circ\text{C}$ (除非另有说明)

参数	测试电路	测试条件	TL431AC、TL432AC			单位
			最小值	典型值	最大值	
V_{ref} 基准电压	请参阅图 8-1	$V_{\text{KA}} = V_{\text{ref}}, I_{\text{KA}} = 10\text{mA}$	2470	2495	2520	mV
$V_{\text{I(dev)}}$ 整个温度范围内的基准输入电压偏差 ⁽¹⁾	请参阅图 8-1	$V_{\text{KA}} = V_{\text{ref}}, I_{\text{KA}} = 10\text{mA}$	SOT23-3 和 TL432 器件	6	16	mV
			所有其他器件	4	25	
$\frac{\Delta V_{\text{ref}}}{\Delta V_{\text{KA}}}$ 基准电压变化与阴极电压变化之比	请参阅图 8-2	$I_{\text{KA}} = 10\text{mA}$	$\Delta V_{\text{KA}} = 10\text{V} - V_{\text{ref}}$	-1.4	-2.7	mV/V
			$\Delta V_{\text{KA}} = 36\text{V} - 10\text{V}$	-1	-2	
I_{ref} 基准输入电流	请参阅图 8-2	$I_{\text{KA}} = 10\text{mA}, R1 = 10\text{k}\Omega, R2 = \infty$	2	4		μA
$I_{\text{I(dev)}}$ 整个温度范围内的基准输入电流偏差 ⁽¹⁾	请参阅图 8-2	$I_{\text{KA}} = 10\text{mA}, R1 = 10\text{k}\Omega, R2 = \infty$	0.8	1.2		μA
I_{min} 调节的最小阴极电流	请参阅图 8-1	$V_{\text{KA}} = V_{\text{ref}}$	0.4	0.6		mA
I_{off} 关闭状态阴极电流	请参阅图 8-3	$V_{\text{KA}} = 36\text{V}, V_{\text{ref}} = 0$	0.1	0.5		μA
$ Z_{\text{KA}} $ 动态阻抗 ⁽²⁾	请参阅图 8-1	$V_{\text{KA}} = V_{\text{ref}}, f \leq 1\text{kHz}, I_{\text{KA}} = 1\text{mA}$ 至 100mA	0.2	0.5		Ω

7.9 电气特性，TL431AI、TL432AI

在推荐的工作条件下测得， $T_A = 25^\circ\text{C}$ (除非另有说明)

参数	测试电路	测试条件	TL431AI、TL432AI			单位
			最小值	典型值	最大值	
V_{ref} 基准电压	请参阅图 8-1	$V_{\text{KA}} = V_{\text{ref}}, I_{\text{KA}} = 10\text{mA}$	2470	2495	2520	mV
$V_{\text{I(dev)}}$ 整个温度范围内的基准输入电压偏差 ⁽¹⁾	请参阅图 8-1	$V_{\text{KA}} = V_{\text{ref}}, I_{\text{KA}} = 10\text{mA}$	SOT23-3 和 TL432 器件	14	34	mV
			所有其他器件	5	50	
$\Delta V_{\text{ref}} / \Delta V_{\text{KA}}$ 基准电压变化与阴极电压变化之比	请参阅图 8-2	$I_{\text{KA}} = 10\text{mA}$	$\Delta V_{\text{KA}} = 10\text{V} - V_{\text{ref}}$	-1.4	-2.7	mV/V
			$\Delta V_{\text{KA}} = 36\text{V} - 10\text{V}$	-1	-2	
I_{ref} 基准输入电流	请参阅图 8-2	$I_{\text{KA}} = 10\text{mA}, R1 = 10\text{k}\Omega, R2 = \infty$		2	4	μA
$I_{\text{I(dev)}}$ 整个温度范围内的基准输入电流偏差 ⁽¹⁾	请参阅图 8-2	$I_{\text{KA}} = 10\text{mA}, R1 = 10\text{k}\Omega, R2 = \infty$		0.8	2.5	μA
I_{min} 调节的最小阴极电流	请参阅图 8-1	$V_{\text{KA}} = V_{\text{ref}}$		0.4	0.7	mA
I_{off} 关闭状态阴极电流	请参阅图 8-3	$V_{\text{KA}} = 36\text{V}, V_{\text{ref}} = 0$		0.1	0.5	μA
$ z_{\text{KA}} $ 动态阻抗 ⁽²⁾	请参阅图 8-1	$V_{\text{KA}} = V_{\text{ref}}, f \leq 1\text{kHz}, I_{\text{KA}} = 1\text{mA}$ 至 100mA		0.2	0.5	Ω

7.10 电气特性, TL431AQ、TL432AQ

在推荐的工作条件下测得, $T_A = 25^\circ\text{C}$ (除非另有说明)

参数	测试电路	测试条件	TL431AQ、TL432AQ			单位
			最小值	典型值	最大值	
V_{ref} 基准电压	请参阅图 8-1	$V_{\text{KA}} = V_{\text{ref}}, I_{\text{KA}} = 10\text{mA}$	2470	2495	2520	mV
$V_{\text{I(dev)}}$ 整个温度范围内的基准输入电压偏差 ⁽¹⁾	请参阅图 8-1	$V_{\text{KA}} = V_{\text{ref}}, I_{\text{KA}} = 10\text{mA}$		14	34	mV
$\frac{\Delta V_{\text{ref}}}{\Delta V_{\text{KA}}}$ 基准电压变化与阴极电压变化之比	请参阅图 8-2	$I_{\text{KA}} = 10\text{mA}$	$\Delta V_{\text{KA}} = 10\text{V} - V_{\text{ref}}$	-1.4	-2.7	mV/V
			$\Delta V_{\text{KA}} = 36\text{V} - 10\text{V}$	-1	-2	
I_{ref} 基准输入电流	请参阅图 8-2	$I_{\text{KA}} = 10\text{mA}, R1 = 10\text{k}\Omega, R2 = \infty$		2	4	μA
$I_{\text{I(dev)}}$ 整个温度范围内的基准输入电流偏差 ⁽¹⁾	请参阅图 8-2	$I_{\text{KA}} = 10\text{mA}, R1 = 10\text{k}\Omega, R2 = \infty$		0.8	2.5	μA
I_{min} 调节的最小阴极电流	请参阅图 8-1	$V_{\text{KA}} = V_{\text{ref}}$		0.4	0.7	mA
I_{off} 关闭状态阴极电流	请参阅图 8-3	$V_{\text{KA}} = 36\text{V}, V_{\text{ref}} = 0$		0.1	0.5	μA
$ z_{\text{KA}} $ 动态阻抗 ⁽²⁾	请参阅图 8-1	$V_{\text{KA}} = V_{\text{ref}}, f \leq 1\text{kHz}, I_{\text{KA}} = 1\text{mA}$ 至 100mA		0.2	0.5	Ω

7.11 电气特性，TL431BC、TL432BC

在推荐的工作条件下测得， $T_A = 25^\circ\text{C}$ (除非另有说明)

参数	测试电路	测试条件	TL431BC、TL432BC			单位
			最小值	典型值	最大值	
V_{ref} 基准电压	请参阅图 8-1	$V_{\text{KA}} = V_{\text{ref}}, I_{\text{KA}} = 10\text{mA}$	2483	2495	2507	mV
$V_{\text{I(dev)}}$ 整个温度范围内的基准输入电压偏差 ⁽¹⁾	请参阅图 8-1	$V_{\text{KA}} = V_{\text{ref}}, I_{\text{KA}} = 10\text{mA}$		6	16	mV
$\frac{\Delta V_{\text{ref}}}{\Delta V_{\text{KA}}}$ 基准电压变化与阴极电压变化之比	请参阅图 8-2	$I_{\text{KA}} = 10\text{mA}$	$\Delta V_{\text{KA}} = 10\text{V} - V_{\text{ref}}$	-1.4	-2.7	mV/V
			$\Delta V_{\text{KA}} = 36\text{V} - 10\text{V}$	-	-2	
I_{ref} 基准输入电流	请参阅图 8-2	$I_{\text{KA}} = 10\text{mA}, R1 = 10\text{k}\Omega, R2 = \infty$		2	4	μA
$I_{\text{I(dev)}}$ 整个温度范围内的基准输入电流偏差 ⁽¹⁾	请参阅图 8-2	$I_{\text{KA}} = 10\text{mA}, R1 = 10\text{k}\Omega, R2 = \infty$		0.8	1.2	μA
I_{min} 调节的最小阴极电流	请参阅图 8-1	$V_{\text{KA}} = V_{\text{ref}}$		0.4	0.6	mA
I_{off} 关闭状态阴极电流	请参阅图 8-3	$V_{\text{KA}} = 36\text{V}, V_{\text{ref}} = 0$		0.1	0.5	μA
$ z_{\text{KA}} $ 动态阻抗 ⁽²⁾	请参阅图 8-1	$V_{\text{KA}} = V_{\text{ref}}, f \leq 1\text{kHz}, I_{\text{KA}} = 1\text{mA}$ 至 100mA		0.2	0.5	Ω

7.12 电气特性, TL431BI、TL432BI

在推荐的工作条件下测得, $T_A = 25^\circ\text{C}$ (除非另有说明)

参数	测试电路	测试条件	TL431BI、TL432BI			单位
			最小值	典型值	最大值	
V_{ref} 基准电压	请参阅图 8-1	$V_{\text{KA}} = V_{\text{ref}}, I_{\text{KA}} = 10\text{mA}$	2483	2495	2507	mV
$V_{\text{I(dev)}}$ 整个温度范围内的基准输入电压偏差 ⁽¹⁾	请参阅图 8-1	$V_{\text{KA}} = V_{\text{ref}}, I_{\text{KA}} = 10\text{mA}$		14	34	mV
$\frac{\Delta V_{\text{ref}}}{\Delta V_{\text{KA}}}$ 基准电压变化与阴极电压变化之比	请参阅图 8-2	$I_{\text{KA}} = 10\text{mA}$	$\Delta V_{\text{KA}} = 10\text{V} - V_{\text{ref}}$	-1.4	-2.7	mV/V
			$\Delta V_{\text{KA}} = 36\text{V} - 10\text{V}$	-1	-2	
I_{ref} 基准输入电流	请参阅图 8-2	$I_{\text{KA}} = 10\text{mA}, R1 = 10\text{k}\Omega, R2 = \infty$		2	4	μA
$I_{\text{I(dev)}}$ 整个温度范围内的基准输入电流偏差 ⁽¹⁾	请参阅图 8-2	$I_{\text{KA}} = 10\text{mA}, R1 = 10\text{k}\Omega, R2 = \infty$		0.8	2.5	μA
I_{min} 调节的最小阴极电流	请参阅图 8-1	$V_{\text{KA}} = V_{\text{ref}}$		0.4	0.7	mA
I_{off} 关闭状态阴极电流	请参阅图 8-3	$V_{\text{KA}} = 36\text{V}, V_{\text{ref}} = 0$		0.1	0.5	μA
$ Z_{\text{KA}} $ 动态阻抗 ⁽²⁾	请参阅图 8-1	$V_{\text{KA}} = V_{\text{ref}}, f \leq 1\text{kHz}, I_{\text{KA}} = 1\text{mA}$ 至 100mA		0.2	0.5	Ω

7.13 电气特性, TL431BQ、TL432BQ

在推荐的工作条件下测得, $T_A = 25^\circ\text{C}$ (除非另有说明)

参数	测试电路	测试条件	TL431BQ、TL432BQ			单位
			最小值	典型值	最大值	
V_{ref} 基准电压	请参阅图 8-1	$V_{\text{KA}} = V_{\text{ref}}, I_{\text{KA}} = 10\text{mA}$	2483	2495	2507	mV
$V_{\text{I(dev)}}$ 整个温度范围内的基准输入电压偏差 ⁽¹⁾	请参阅图 8-1	$V_{\text{KA}} = V_{\text{ref}}, I_{\text{KA}} = 10\text{mA}$		14	34	mV
$\frac{\Delta V_{\text{ref}}}{\Delta V_{\text{KA}}}$ 基准电压变化与阴极电压变化之比	请参阅图 8-2	$I_{\text{KA}} = 10\text{mA}$	$\Delta V_{\text{KA}} = 10\text{V} - V_{\text{ref}}$	-1.4	-2.7	mV/V
			$\Delta V_{\text{KA}} = 36\text{V} - 10\text{V}$	-1	-2	
I_{ref} 基准输入电流	请参阅图 8-2	$I_{\text{KA}} = 10\text{mA}, R1 = 10\text{k}\Omega, R2 = \infty$		2	4	μA
$I_{\text{I(dev)}}$ 整个温度范围内的基准输入电流偏差 ⁽¹⁾	请参阅图 8-2	$I_{\text{KA}} = 10\text{mA}, R1 = 10\text{k}\Omega, R2 = \infty$		0.8	2.5	μA
I_{min} 调节的最小阴极电流	请参阅图 8-1	$V_{\text{KA}} = V_{\text{ref}}$		0.4	0.7	mA
I_{off} 关闭状态阴极电流	请参阅图 8-3	$V_{\text{KA}} = 36\text{V}, V_{\text{ref}} = 0$		0.1	0.5	μA
$ Z_{\text{KA}} $ 动态阻抗 ⁽²⁾	请参阅图 8-1	$V_{\text{KA}} = V_{\text{ref}}, f \leq 1\text{kHz}, I_{\text{KA}} = 1\text{mA}$ 至 100mA		0.2	0.5	Ω

典型特性

高温和低温下的数据仅适用于各种器件在自然通风条件下的推荐工作温度范围内。



图 7-1. 基准电压与自然通风温度之间的关系



图 7-2. 基准电流与自然通风温度之间的关系

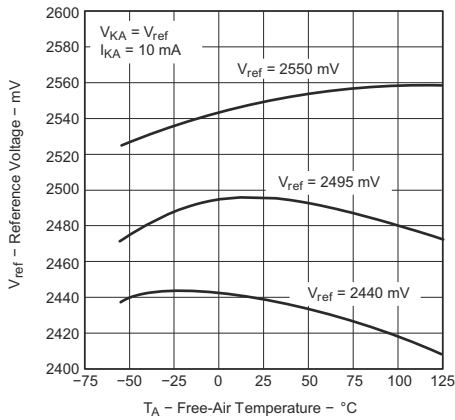

图 7-3. 阴极电流与阴极电压之间的关系

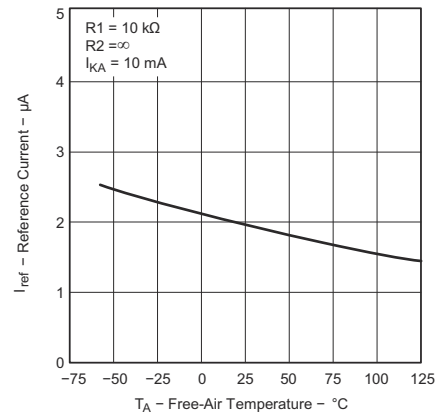

图 7-4. 阴极电流与阴极电压之间的关系

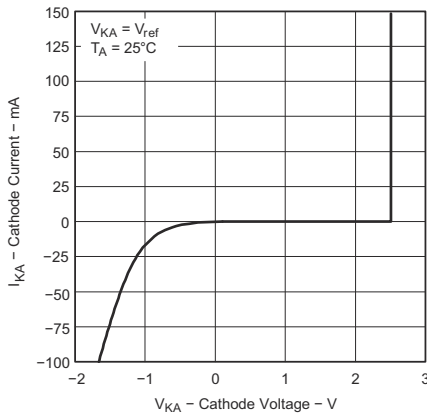

图 7-5. 关闭状态阴极电流与自然通风条件下的温度之间的关系

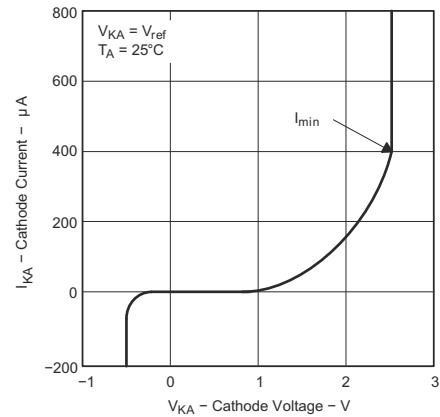

图 7-6. Δ 基准电压与 Δ 阴极电压之比与自然通风条件下的温度之间的关系

典型特性

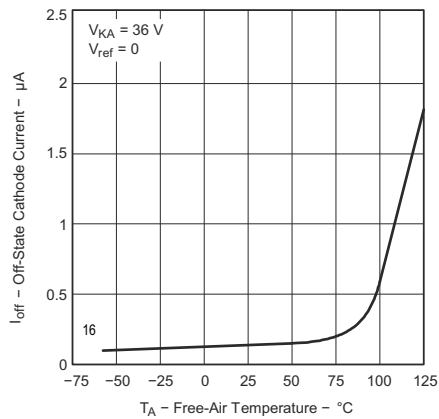
高温和低温下的数据仅适用于各种器件在自然通风条件下的推荐工作温度范围内。

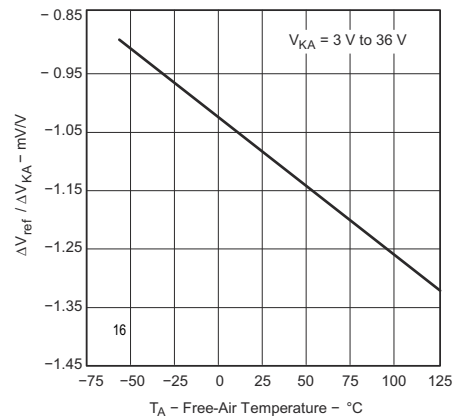

图 7-7. 等效输入噪声电压与频率之间的关系



图 7-8. 10S 周期内的等效输入噪声电压

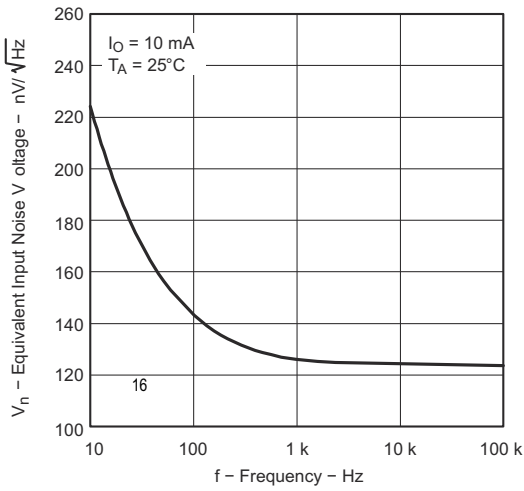

图 7-9. 10S 周期内等效输入噪声电压的测试电路

典型特性

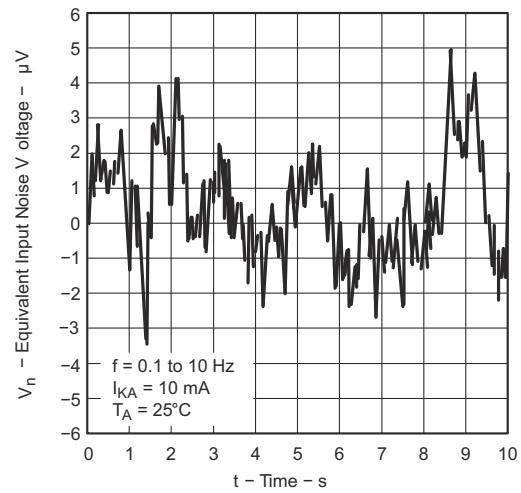
高温和低温下的数据仅适用于各种器件在自然通风条件下的推荐工作温度范围内。

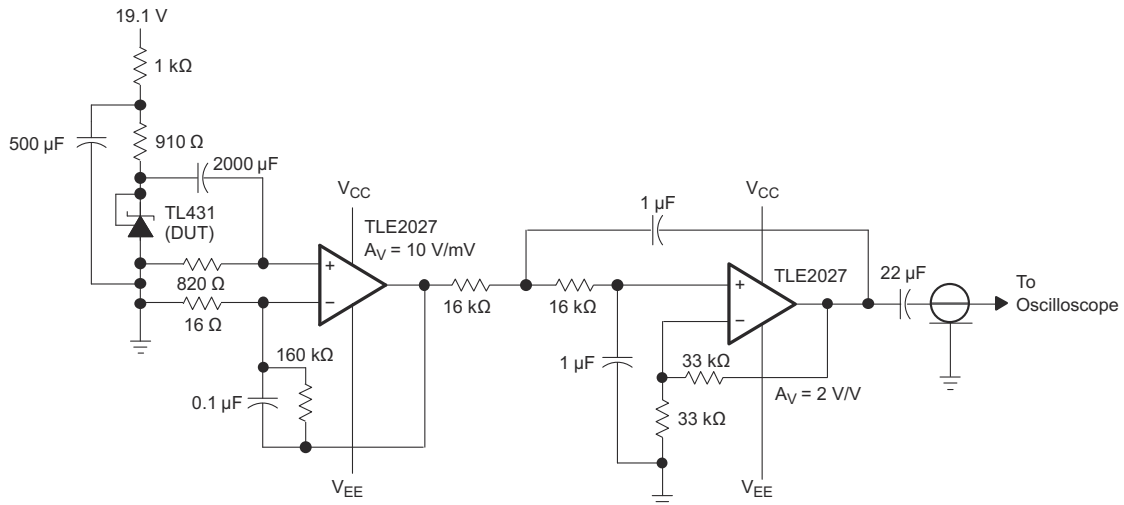

图 7-10. 小信号电压放大与频率之间的关系



图 7-11. 电压放大测试电路

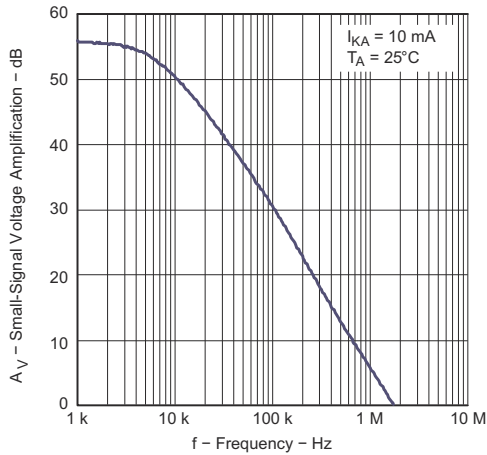

图 7-12. 基准阻抗与频率之间的关系

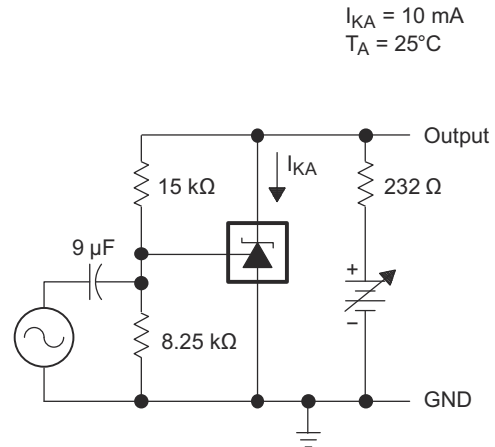

图 7-13. 基准阻抗测试电路

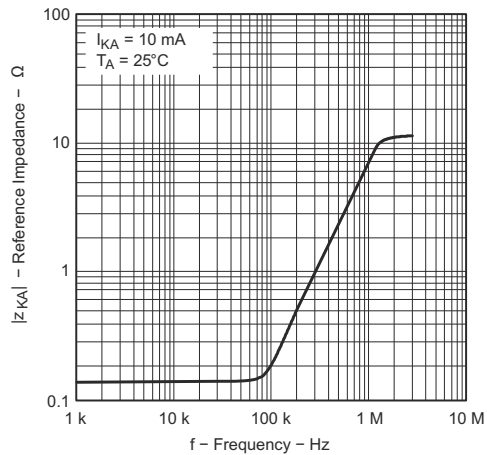

图 7-14. 脉冲响应

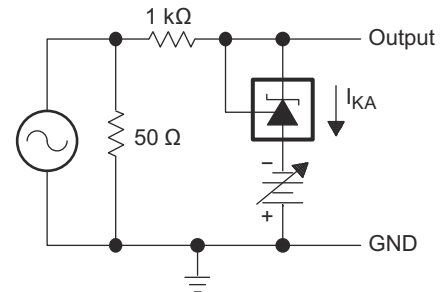

图 7-15. 脉冲响应测试电路

典型特性

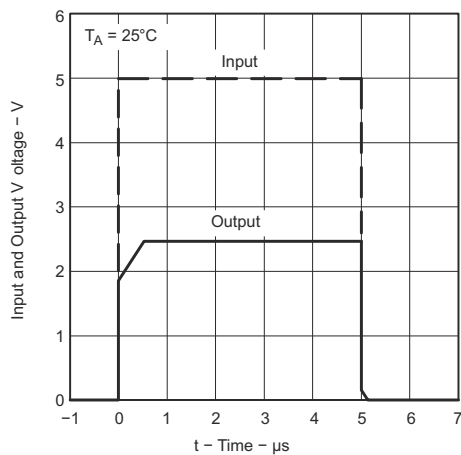
高温和低温下的数据仅适用于各种器件在自然通风条件下的推荐工作温度范围内。

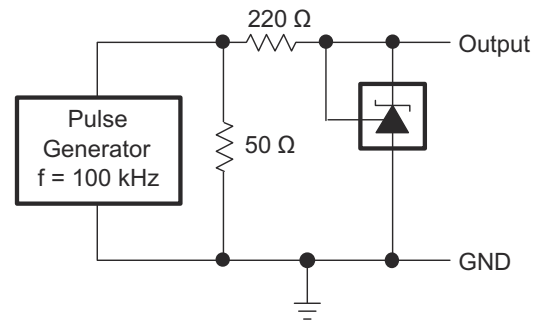
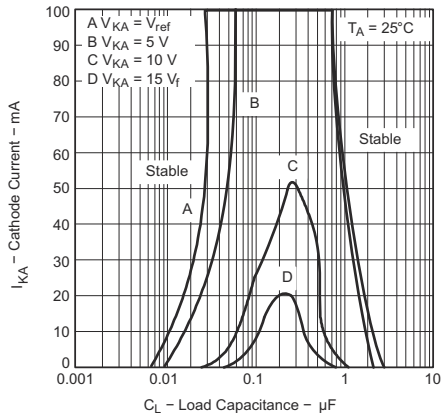

曲线下的区域表示可能导致器件振荡的条件。针对曲线 B、C 和 D，对 R2 和 V+ 进行了调整，以建立初始 V_{KA} 和 I_{KA} 条件，且 $C_L = 0$ 。然后，对 V_{BATT} 和 C_L 进行了调整，以确定稳定范围。

图 7-16. 所有 TL431 和 TL431A 器件的稳定性边界条件 (SOT23-3、SC-70 和 Q 级温度器件除外)

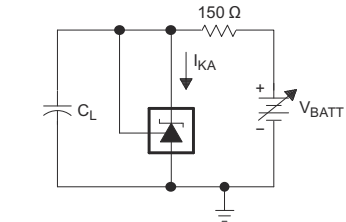

TEST CIRCUIT FOR CURVE A

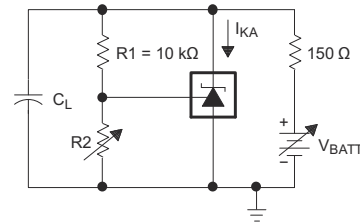

TEST CIRCUIT FOR CURVES B, C, AND D

图 7-17. 稳定性边界条件测试电路

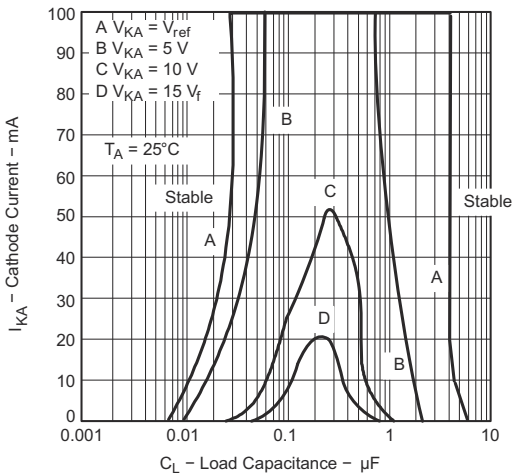

曲线下的区域表示可能导致器件振荡的条件。针对曲线 B、C 和 D，对 R2 和 V+ 进行了调整，以建立初始 V_{KA} 和 I_{KA} 条件，且 $C_L = 0$ 。然后，对 V_{BATT} 和 C_L 进行了调整，以确定稳定范围。

图 7-18. 所有 TL431B、TL432、SOT-23、SC-70 和 Q 级温度器件的稳定性边界条件

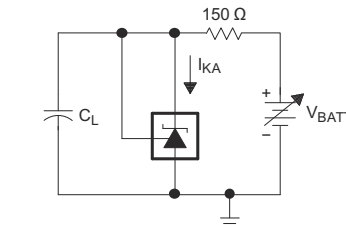

TEST CIRCUIT FOR CURVE A

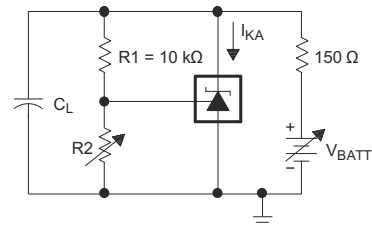

TEST CIRCUIT FOR CURVES B, C, AND D

图 7-19. 稳定性边界条件测试电路

8 参数测量信息



图 8-1. 针对 $V_{KA} = V_{ref}$ 的测试电路



图 8-2. 针对 $V_{KA} > V_{ref}$ 的测试电路

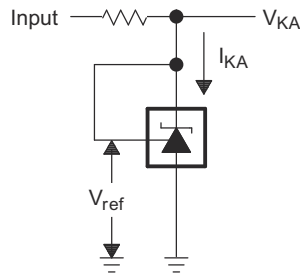

图 8-3. 针对 I_{off} 的测试电路

9 详细说明

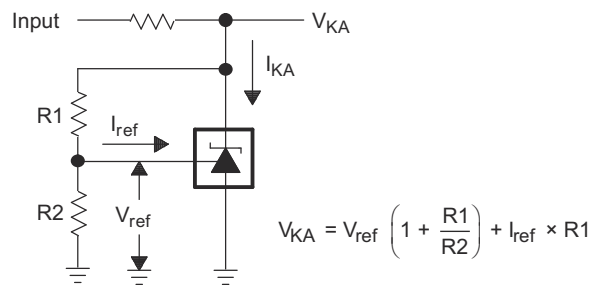
9.1 概述

此标准器件已经证明可广泛应用于从电源到信号路径的各种应用。这是由于它的关键组件包含精确的电压基准和运算放大器，这是非常基本的模拟构建块。TL43xx 与其关键元器件搭配使用，可用作单个电压基准、误差放大器、电压钳位或具有集成基准的比较器。

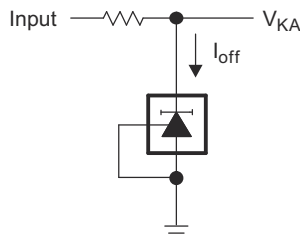
TL43xx 能够运行并调整到 2.5V 至 36V 的阴极电压，这使得该器件成为了工业、汽车、电信和计算领域中各种终端设备的最佳选择。若要将该器件用作并联稳压器或误差放大器，必须为阴极引脚提供 $>1\text{mA}$ ($I_{\text{min(max)}}$) 的电流。在这种情况下，可以从阴极引脚和基准引脚施加反馈，以创建内部基准电压的副本。

您可以购买初始容差为 0.5%、1% 和 2% (在 25°C 条件下) 的各种基准电压选项。这些基准选项以在 TL431 或 TL432 之后跟 B (0.5%)、A (1.0%) 和空白 (2.0%) 的形式表示。TL431 和 TL432 的功能相同，但具有不同的引脚排列选项。

TL43xxC 器件运行温度范围为 0°C 至 70°C，TL43xxI 器件运行温度范围为 -40°C 至 85°C，TL43xxQ 器件运行温度范围为 -40°C 至 125°C。

9.2 功能方框图



图 9-1. 等效原理图



图 9-2. 详细的原理图

9.3 特性说明

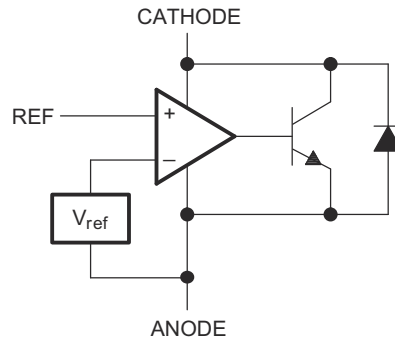
TL43xx 由内部基准和根据基准引脚和虚拟内部引脚之间的差异输出灌电流的放大器组成。该灌电流由内部达林顿对产生，如上文中的原理图（图 9-2）所示。使用达林顿对是为了使该器件能够吸收最高 100mA 的电流。

在具有足够电压余量 ($\geq 2.5V$) 和阴极电流 (I_{KA}) 的情况下，TL431 会强行将基准引脚的电压控制在 2.5V。但是，基准引脚不能悬空，因为它需要 $I_{REF} \geq 4\mu A$ （请参阅 [电气特性](#)，[TL431C](#)、[TL432C](#)）。这是因为基准引脚会被驱动到 npn 中，后者要有基极电流才能正常工作。

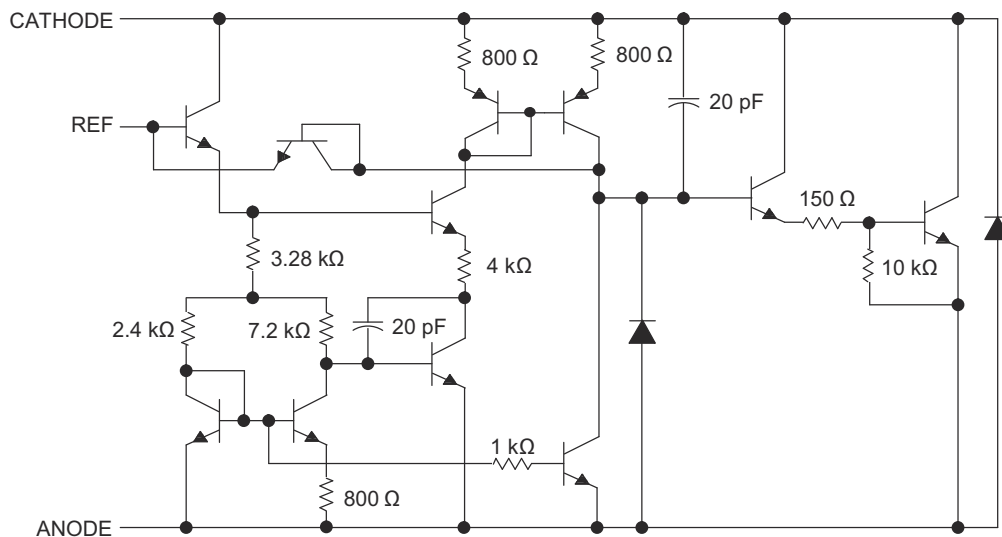
当从阴极引脚和基准引脚施加反馈时，TL43xx 将作为齐纳二极管，根据向阴极提供的电流将输出电压调节至恒定电压。这是由于内部放大器和基准进入了适当的运行区域。在开环、伺服或误差放大实现中，为了使该器件保持在合适的线性区域，必须向其施加与在反馈情况下所需电流的大小相同的电流，从而使 TL43xx 具有足够的增益。

与许多线性稳压器不同的是，TL43xx 通过内部补偿来达到稳定，无需在阴极和阳极之间使用输出电容器。但是，如果需要为该器件使用输出电容器，图 9-2 可提供指导，帮助用户选择用于保持稳定性的合适电容器。

9.4 器件功能模式

9.4.1 开环（比较器）

当 TL43xx 的阴极/输出电压或电流未以任何形式馈送回基准/输入引脚时，该器件便是处于开环状态。在向该器件施加合适的阴极电流 (I_{KA}) 后，TL43xx 将会具有图 9-1 中所示的特性。这种配置具有如此高的增益，因此 TL43xx 通常用作比较器。TL43xx 具有集成的内部基准，因此，当用户想要监控单个信号的某个电平时，该器件便成为了他们的理想选择。

9.4.2 闭环

当 TL43xx 的阴极/输出电压或电流以任何形式馈送回基准/输入引脚时，该器件便是处于闭环状态。涉及 TL43xx 的多数应用都是采用这种模式，从而实现调节至固定电压或电流的目的。反馈使得该器件能够作为误差放大器，计算输出电压的一部分，并对其进行调整以保持期望的调节。实现该目标的途径是：将输出电压以某种方式关联至基准引脚，从而使其等于内部基准电压（这可以通过电阻反馈或直接反馈来实现）。

10 应用和实现

备注

以下应用部分中的信息不属于 TI 元件规范，TI 不担保其准确性和完整性。TI 的客户应负责确定各元件是否适用于其应用。客户应验证并测试其设计实现，以确保系统功能正常。

10.1 应用信息

该器件具有很多应用和设置，因此许多情况都无法在本数据表中进行详述。链接的应用手册可帮助设计人员在使用此器件时制定理想的选择。

应用手册 [了解 TL431/TL432 数据表中的稳定性边界条件图 \(SLVA482\)](#) 可帮助用户更深入地了解此类器件的稳定性特征和选择合适的负载电容器。应用手册 [在可调并联稳压器上设置并联电压 \(SLVA445\)](#) 可协助设计人员设置并联电压，以达到该设备的理想精度。

10.2 典型应用

10.2.1 具有集成基准的比较器



图 10-1. 比较器应用原理图

10.2.1.1 设计要求

本设计示例使用表 10-1 中所列的参数作为输入参数。

表 10-1. 设计参数

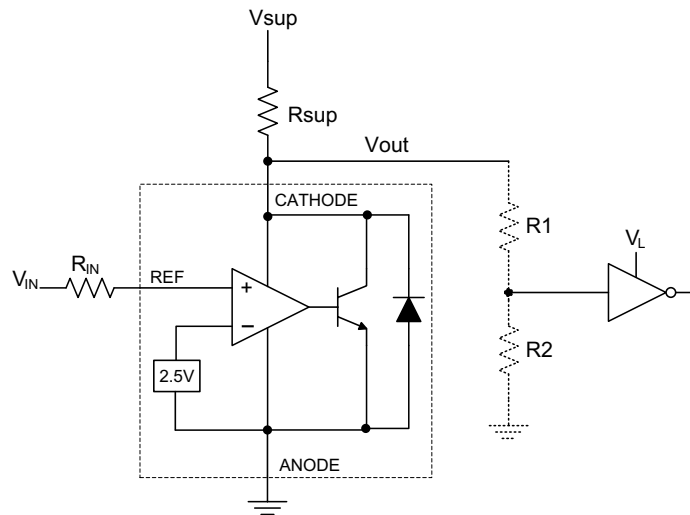
设计参数	示例值
输入电压范围	0V 至 5V
输入电阻	10k Ω
电源电压	24V
阴极电流 (I_K)	5mA
输出电压电平	$\sim 2V - V_{SUP}$
逻辑输入阈值 $V_{IH/VIL}$	V_L

10.2.1.2 详细设计过程

在将 TL431 用作具有基准电压的比较器时，需要确定以下参数：

- 输入电压范围
- 基准电压精度
- 输出/逻辑输入高低电平阈值
- 电流源电阻

10.2.1.2.1 基本操作

在图 10-1 所示的配置中，TL431 将作为比较器，将 V_{REF} 引脚电压与内部虚拟基准电压进行比较。在获得合适的阴极电流 (I_K) 时，TL43xx 将具有足够的开环增益来提供快速响应。图 10-2 展示了这种情况，其中 $R_{SUP}=10k\Omega$ ($I_{KA}=500\mu A$) 的情况要比 $R_{SUP}=1k\Omega$ ($I_{KA}=5mA$) 时的响应速度慢得多。TL43xx 的最大工作电流 (I_{MIN}) 为 1mA，因此低于该电流值运行可能会导致增益降低，从而使响应速度变慢。

10.2.1.2.1.1 过驱

未为基准引脚提供足够的过驱动电压也可能导致响应较慢或不准确。该电压高于内部虚拟基准电压。内部虚拟基准电压将在 $2.5V \pm 0.5\%$ 、 1.0% 或 1.5% (具体取决于所使用的版本) 范围内。所提供的过驱动电压越高，TL431 的响应速度就会越快。

对于 TL431 用作比较器的应用，最好是将跳闸点设置为高于正预期误差 (对于 A 版本来说是 $+1.0\%$) 为了实现快速响应，将跳闸点设置为高于内部 V_{REF} 的 10% 就足够了。

为了实现从 V_{in} 到基准引脚的最低压降或电压差，建议使用阻值低于 $10k\Omega$ 的输入电阻器来提供 I_{ref} 。

10.2.1.2.2 输出电压和逻辑输入电平

为了使 TL431 能够正常地用作比较器，逻辑输出必须可供逻辑接收器件读取。这是通过了解输入高低电平阈值电压电平（通常表示为 V_{IH} 和 V_{IL} ）来实现的。

如图 10-2 中所示，TL431 在开环/比较器模式下的输出低电平电压大约为 2V，这通常已经足够支持 5V 的供应逻辑。但却无法支持 3.3V 和 1.8V 的供应逻辑。为了适应这种情况，可以在输出端连接一个电阻分压器，以将输出电压衰减到方便低电压逻辑接收器件读取的电压。

TL431 的输出高电压等于 V_{SUP} ，因为 TL431 处于集电极开路状态。如果 V_{SUP} 远高于接收逻辑的最大输入电压容差，则必须对输出进行衰减，以确保输出逻辑的稳定性。

当在输出端上使用电阻分压器时，务必要使电阻分压器（图 10-1 中的 R1 和 R2）的和远高于 R_{SUP} ，以免影响 TL431 在关闭时将电压拉近至 V_{SUP} 的能力。

10.2.1.2.2.1 输入电阻

在此应用中，TL431 需要具有输入电阻，以确保此器件所提供的所需基准拉电流 (I_{REF}) 在开启期间保持在合适的运行区域内。基准引脚上的实际电压为 $V_{REF}=V_{IN}-I_{REF}*R_{IN}$ 。 I_{REF} 可能会高达 $4\mu A$ ，因此建议使用足够小的电阻，这将能够减小 I_{REF} 通过 V_{IN} 造成的误差。

10.2.1.3 应用曲线



图 10-2. 各种阴极电流情况下的输出响应

10.2.2 并联稳压器/基准

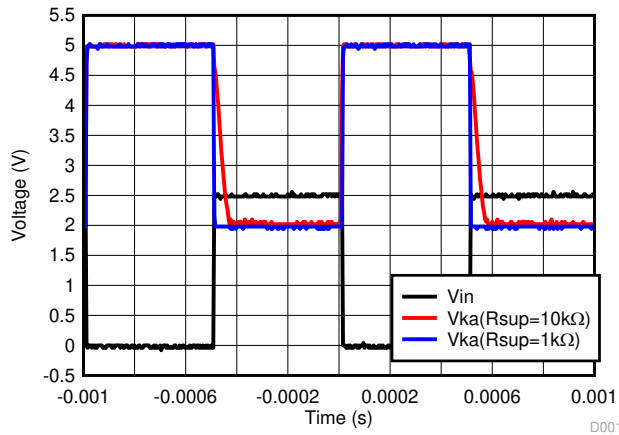

图 10-3. 并联稳压器原理图

10.2.2.1 设计要求

本设计示例使用表 10-1 中所列的参数作为输入参数。

表 10-2. 设计参数

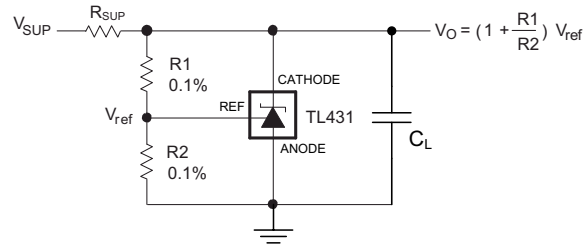
设计参数	示例值
基准初始精度	1.0 %
电源电压	24V
阴极电流 (I _k)	5mA
输出电压电平	2.5V - 36V
负载电容	100nF
反馈电阻器值和精度 (R1 和 R2)	10k Ω

10.2.2.2 详细设计过程

在将 TL431 用作并联稳压器时，需要确定以下参数：

- 输入电压范围
- 温度范围
- 总精度
- 阴极电流
- 基准初始精度
- 输出电容

10.2.2.2.1 可编程输出/阴极电压

为了将阴极电压编程至调节电压，必须对阴极和阳极引脚之间的电阻桥进行分流，即将中点处连接至基准引脚。您可以在图 10-3 中看到该电路，其中电阻桥由 R1 和 R2 组成。您可以使用图 10-3 中所示的公式计算出并联稳压器配置中的阴极/输出电压近似值。您还可以通过考虑阴极电流，更精确地确定阴极电压：

$$V_O = (1 + R1/R2) * V_{REF} - I_{REF} * R1$$

为了使该公式有效，TL43xx 必须完全偏置，以便它具有足够的开环增益来减小任何增益误差。这可以通过满足第 7.5 中指示的 I_{min} 规格来实现。

10.2.2.2.2 总精度

当对高于单位增益 ($V_{KA}=V_{REF}$) 的输出进行编程时，除 V_{REF} 之外，TL43xx 还容易受其他误差的影响，这些误差可能会影响整体精度。这些误差包括：

- R1 和 R2 的精度
- $V_{I(dev)}$ - 基准电压随温度的变化
- $\Delta V_{REF} / \Delta V_{KA}$ - 基准电压变化与阴极电压变化之比
- $|z_{KA}|$ - 动态阻抗，通过阴极电流导致阴极电压的变化

将所有这些变量考虑在内，便可确定最坏情况下的阴极电压。应用手册 [在可调并联稳压器上设置并联电压 \(SLVA445\)](#) 可协助设计人员设置并联电压，以达到该设备的理想精度。

10.2.2.2.3 稳定性

虽然 TL43xx 在没有容性负载的情况下是稳定的，但是接收并联稳压器输出电压的器件可能会产生 TL43xx 稳定区域 (如 [图 7-16](#) 和 [图 7-18](#) 中所示) 内的容性负载。此外，设计人员可以使用容性负载来改进瞬态响应或进行电源去耦。在阴极和阳极之间使用额外电容时，请参阅 [图 7-16](#) 和 [图 7-18](#)。此外，应用手册 [了解 TL431/TL432 数据表中的稳定性边界条件图 \(SLVA482\)](#) 可帮助用户更深入地了解此类器件的稳定性特征和选择合适的负载电容器。

10.2.2.2.4 启动时间

如 [图 10-4](#) 中所示，TL43xx 具有高达约 2V 的快速响应，然后会缓慢充电至其编程值。这得益于 TL43xx 为了达到稳定性标准而配备的补偿电容 (如 [图 9-2](#) 所示)。尽管存在二次延迟，TL43xx 的快速响应仍然能够满足许多钳位应用的需要。

10.2.2.3 应用曲线



图 10-4. TL43xx 启动响应

10.3 系统示例

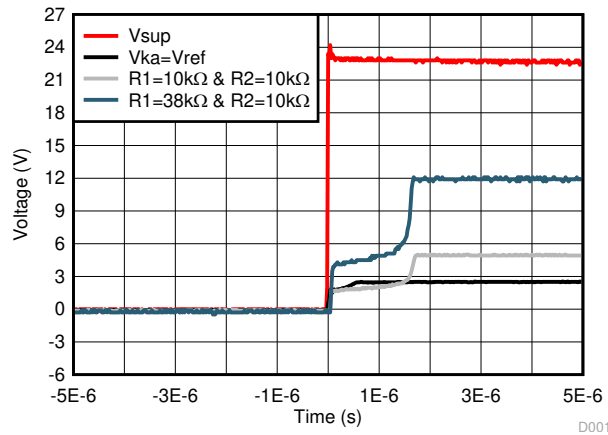
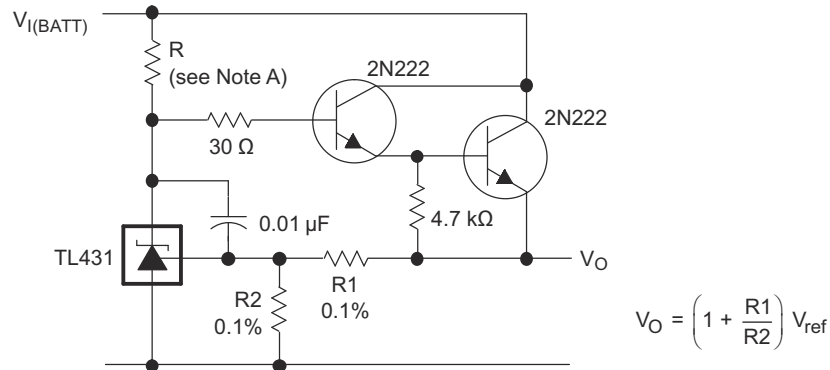

A. R 应在最低 $V_{(BATT)}$ 情况下向 TL431 提供 $\geq 1\text{mA}$ 的阴极电流。

图 10-5. 精密大电流串联稳压器



图 10-6. 三端固定稳压器的输出控制



图 10-7. 大电流并联稳压器

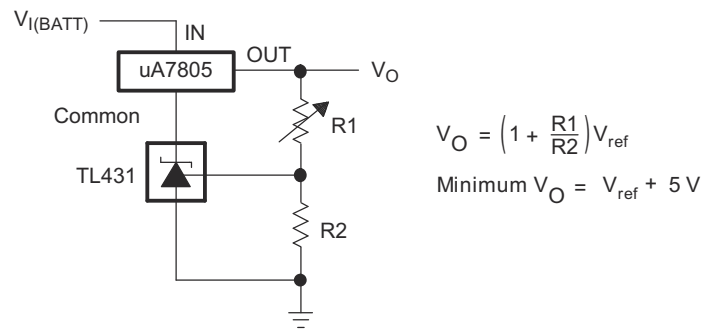

A. 请参阅图 7-16 和图 7-18 中的稳定性边界条件，以确定 C 的允许值。

图 10-8. Crowbar 电路

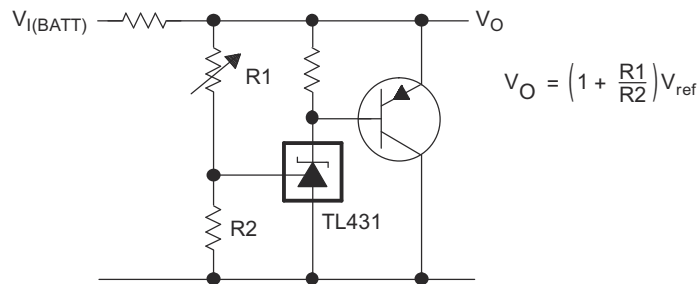
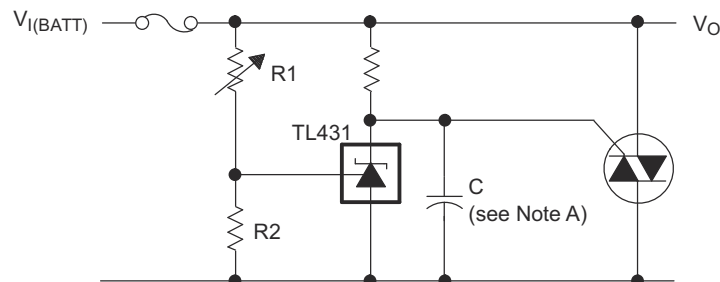

图 10-9. 精密 5V 1.5A 稳压器



A. R_b 应向 TL431 提供 $\geq 1\text{mA}$ 的阴极电流。

图 10-10. 高效 5V 精密稳压器

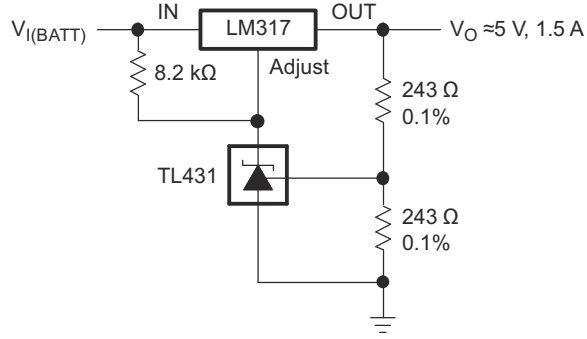
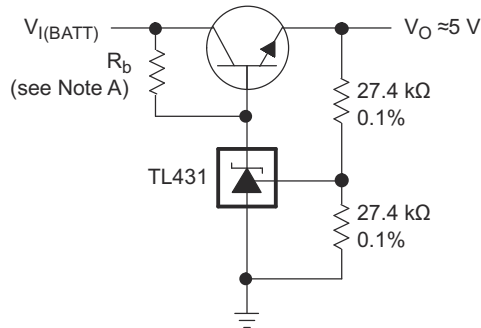

图 10-11. 具有基准电压的 PWM 转换器



A. 选择 R3 和 R4，以在可用的 $V_{I(BATT)}$ 条件下提供所需的 LED 强度并为 TL431 提供 $\geq 1\text{mA}$ 的阴极电流。

图 10-12. 电压监控器

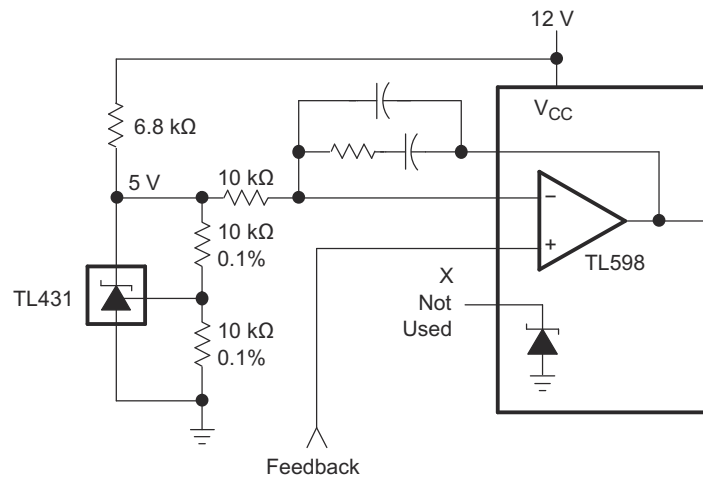
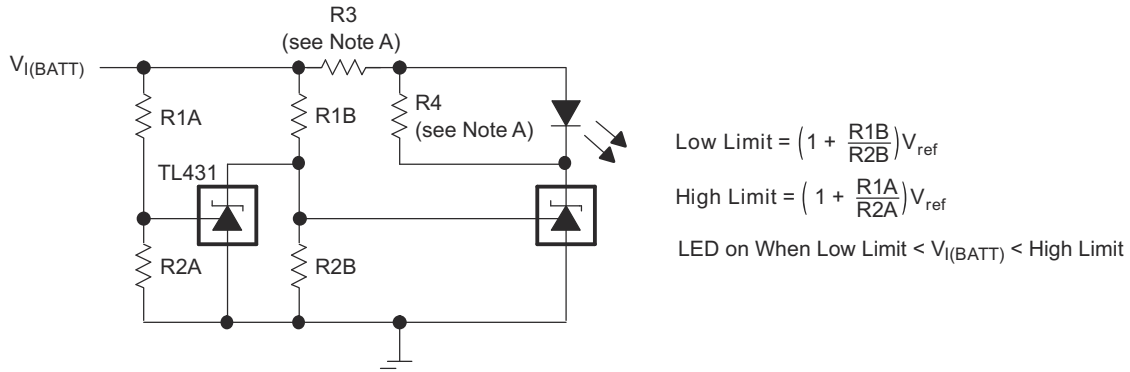

图 10-13. 延迟计时器



图 10-14. 精密限流器

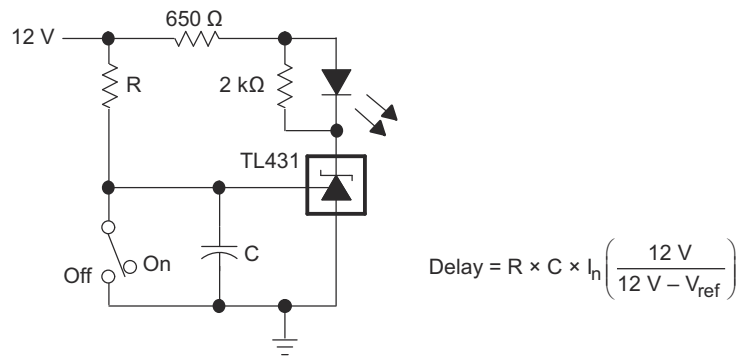

图 10-15. 精密恒定电流吸收器

11 电源相关建议

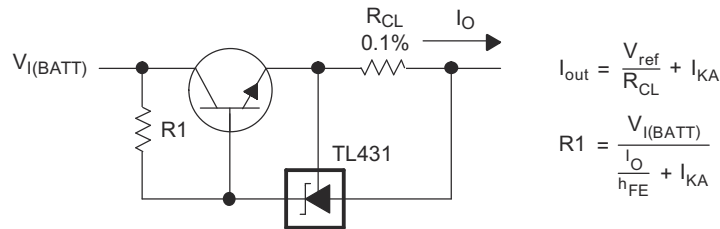
当使用 TL43xx 作为线性稳压器来为负载供电时，设计人员通常会在输出/阴极引脚上使用旁路电容。这样做时，请确保电容符合图 7-16 和图 7-18 中所示的稳定性标准。

为了避免超出最大阴极电流，请确保电源电压符合电流要求的限制。另外，请务必限制流入基准引脚的电流，以免其超过绝对最大额定值。

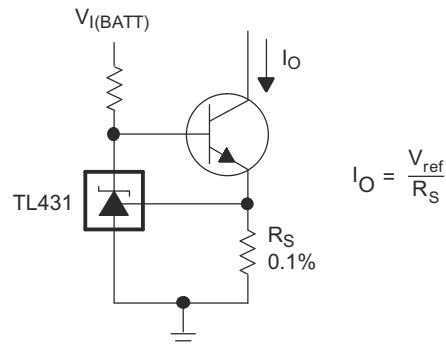
对于分流高电流的应用，请注意阴极和阳极迹线的长度，从而调整迹线宽度以获得适当的电流密度。

12 布局

12.1 布局指南

旁路电容器应尽可能靠近该部件。载流迹线需要具有适合其所承载的电流量的宽度；对于 TL43xx，这些电流很低。

12.2 布局示例



图 12-1. DBZ 布局示例

13 器件和文档支持

13.1 器件命名规则

TI 通过分配前缀和后缀来区分 TL43x 系列的所有组合。环保计划标识符是曾用于区分无铅和绿色环保器件的旧标识符。更多详细信息和可以订购的组合请参阅[机械、封装和可订购信息](#)中的“封装选项附录”。

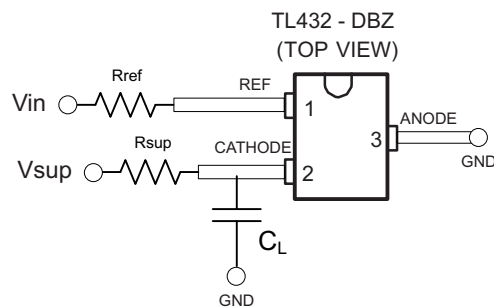
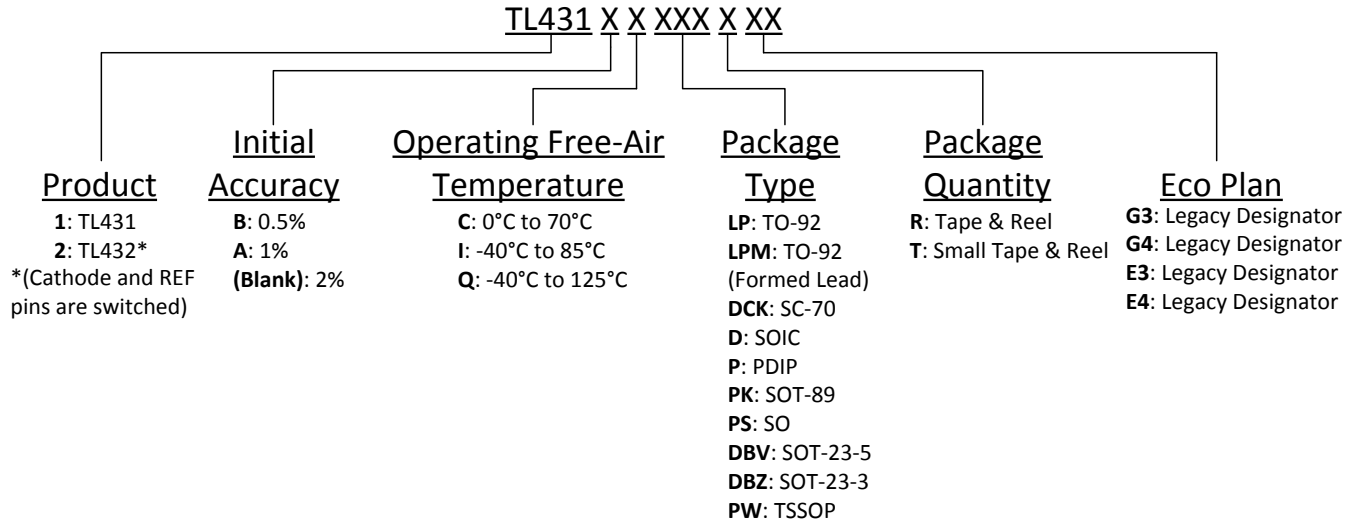

13.2 相关链接

下表列出了快速访问链接。类别包括技术文档、支持和社区资源、工具和软件，以及申请样片或购买产品的快速链接。

表 13-1. 相关链接

器件	产品文件夹	样片与购买	技术文档	工具和软件	支持和社区
TL431	点击此处	点击此处	点击此处	点击此处	点击此处
TL432	点击此处	点击此处	点击此处	点击此处	点击此处

13.3 接收文档更新通知

要接收文档更新通知，请导航至 ti.com 上的器件产品文件夹。点击 [订阅更新](#) 进行注册，即可每周接收产品信息更改摘要。有关更改的详细信息，请查看任何已修订文档中包含的修订历史记录。

13.4 支持资源

[TI E2E™ 支持论坛](#) 是工程师的重要参考资料，可直接从专家获得快速、经过验证的解答和设计帮助。搜索现有解答或提出自己的问题可获得所需的快速设计帮助。

链接的内容由各个贡献者“按原样”提供。这些内容并不构成 TI 技术规范，并且不一定反映 TI 的观点；请参阅 TI 的 [《使用条款》](#)。

13.5 商标

TI E2E™ is a trademark of Texas Instruments.

所有商标均为其各自所有者的财产。

13.6 Electrostatic Discharge Caution



This integrated circuit can be damaged by ESD. Texas Instruments recommends that all integrated circuits be handled with appropriate precautions. Failure to observe proper handling and installation procedures can cause damage.

ESD damage can range from subtle performance degradation to complete device failure. Precision integrated circuits may be more susceptible to damage because very small parametric changes could cause the device not to meet its published specifications.

13.7 术语表

[TI 术语表](#) 本术语表列出并解释了术语、首字母缩略词和定义。

14 机械、封装和可订购信息

以下页面包含机械、封装和可订购信息。这些信息是指定器件可用的最新数据。数据如有变更，恕不另行通知，且不会对此文档进行修订。如需获取此数据表的浏览器版本，请查阅左侧的导航栏。

PACKAGING INFORMATION

Orderable Device	Status (1)	Package Type	Package Drawing	Pins	Package Qty	Eco Plan (2)	Lead finish/ Ball material (6)	MSL Peak Temp (3)	Op Temp (°C)	Device Marking (4/5)	Samples
TL431ACD	ACTIVE	SOIC	D	8	75	RoHS & Green	NIPDAU	Level-1-260C-UNLIM	0 to 70	431AC	Samples
TL431ACDBVR	ACTIVE	SOT-23	DBV	5	3000	RoHS & Green	NIPDAU SN	Level-1-260C-UNLIM	0 to 70	(TACG, TACJ, TACS)	Samples
TL431ACDBVRE4	ACTIVE	SOT-23	DBV	5	3000	RoHS & Green	NIPDAU	Level-1-260C-UNLIM	0 to 70	TACG	Samples
TL431ACDBVRG4	ACTIVE	SOT-23	DBV	5	3000	RoHS & Green	NIPDAU	Level-1-260C-UNLIM	0 to 70	TACG	Samples
TL431ACDBVT	ACTIVE	SOT-23	DBV	5	250	RoHS & Green	NIPDAU SN	Level-1-260C-UNLIM	0 to 70	(TACG, TACJ, TACU)	Samples
TL431ACDBZR	ACTIVE	SOT-23	DBZ	3	3000	RoHS & Green	NIPDAU SN NIPDAUAG	Level-1-260C-UNLIM	0 to 70	(TAC3, TACG, TACS, TACU)	Samples
TL431ACDBZRG4	ACTIVE	SOT-23	DBZ	3	3000	RoHS & Green	NIPDAU	Level-1-260C-UNLIM	0 to 70	TAC3	Samples
TL431ACDBZT	ACTIVE	SOT-23	DBZ	3	250	RoHS & Green	NIPDAU SN	Level-1-260C-UNLIM	0 to 70	(TAC3, TACG, TACS, TACU)	Samples
TL431ACDBZTG4	ACTIVE	SOT-23	DBZ	3	250	RoHS & Green	NIPDAU	Level-1-260C-UNLIM	0 to 70	TAC3	Samples
TL431ACDCKR	ACTIVE	SC70	DCK	6	3000	RoHS & Green	NIPDAU	Level-1-260C-UNLIM	0 to 70	(T4S, T4U)	Samples
TL431ACDG4	ACTIVE	SOIC	D	8	75	RoHS & Green	NIPDAU	Level-1-260C-UNLIM	0 to 70	431AC	Samples
TL431ACDR	ACTIVE	SOIC	D	8	2500	RoHS & Green	NIPDAU SN	Level-1-260C-UNLIM	0 to 70	431AC	Samples
TL431ACDRE4	ACTIVE	SOIC	D	8	2500	RoHS & Green	NIPDAU	Level-1-260C-UNLIM	0 to 70	431AC	Samples
TL431ACDRG4	ACTIVE	SOIC	D	8	2500	RoHS & Green	NIPDAU	Level-1-260C-UNLIM	0 to 70	431AC	Samples
TL431ACLP	ACTIVE	TO-92	LP	3	1000	RoHS & Green	SN	N / A for Pkg Type	0 to 70	TL431AC	Samples
TL431ACLPE3	ACTIVE	TO-92	LP	3	1000	RoHS & Green	SN	N / A for Pkg Type	0 to 70	TL431AC	Samples
TL431ACLPM	ACTIVE	TO-92	LP	3	2000	RoHS & Green	SN	N / A for Pkg Type	0 to 70	TL431AC	Samples
TL431ACLPME3	ACTIVE	TO-92	LP	3	2000	RoHS & Green	SN	N / A for Pkg Type	0 to 70	TL431AC	Samples
TL431ACLPR	ACTIVE	TO-92	LP	3	2000	RoHS & Green	SN	N / A for Pkg Type	0 to 70	TL431AC	Samples

Orderable Device	Status (1)	Package Type	Package Drawing	Pins	Package Qty	Eco Plan (2)	Lead finish/ Ball material (6)	MSL Peak Temp (3)	Op Temp (°C)	Device Marking (4/5)	Samples
TL431ACLPRE3	ACTIVE	TO-92	LP	3	2000	RoHS & Green	SN	N / A for Pkg Type	0 to 70	TL431AC	Samples
TL431ACP	ACTIVE	PDIP	P	8	50	RoHS & Green	NIPDAU	N / A for Pkg Type	0 to 70	TL431ACP	Samples
TL431ACPK	ACTIVE	SOT-89	PK	3	1000	RoHS & Green	SN	Level-2-260C-1 YEAR	0 to 70	4A	Samples
TL431ACPKG3	ACTIVE	SOT-89	PK	3	1000	RoHS & Green	SN	Level-2-260C-1 YEAR	0 to 70	4A	Samples
TL431ACPSR	ACTIVE	SO	PS	8	2000	RoHS & Green	NIPDAU	Level-1-260C-UNLIM	0 to 70	T431A	Samples
TL431ACPW	ACTIVE	TSSOP	PW	8	150	RoHS & Green	NIPDAU	Level-1-260C-UNLIM	0 to 70	T431A	Samples
TL431ACPWR	ACTIVE	TSSOP	PW	8	2000	RoHS & Green	NIPDAU	Level-1-260C-UNLIM	0 to 70	T431A	Samples
TL431AID	ACTIVE	SOIC	D	8	75	RoHS & Green	NIPDAU	Level-1-260C-UNLIM	-40 to 85	431AI	Samples
TL431AIDBVR	ACTIVE	SOT-23	DBV	5	3000	RoHS & Green	NIPDAU SN	Level-1-260C-UNLIM	-40 to 85	(TAIG, TAIJ, TAIS)	Samples
TL431AIDBVRE4	ACTIVE	SOT-23	DBV	5	3000	RoHS & Green	NIPDAU	Level-1-260C-UNLIM	-40 to 85	TAIG	Samples
TL431AIDBVRG4	ACTIVE	SOT-23	DBV	5	3000	RoHS & Green	NIPDAU	Level-1-260C-UNLIM	-40 to 85	TAIG	Samples
TL431AIDBVT	ACTIVE	SOT-23	DBV	5	250	RoHS & Green	NIPDAU SN	Level-1-260C-UNLIM	-40 to 85	(TAIG, TAIJ, TAIU)	Samples
TL431AIDBVTG4	ACTIVE	SOT-23	DBV	5	250	RoHS & Green	NIPDAU	Level-1-260C-UNLIM	-40 to 85	TAIG	Samples
TL431AIDBZR	ACTIVE	SOT-23	DBZ	3	3000	RoHS & Green	NIPDAU SN	Level-1-260C-UNLIM	-40 to 85	(T3AG, TA13, TAIS, TAIU)	Samples
TL431AIDBZRG4	ACTIVE	SOT-23	DBZ	3	3000	RoHS & Green	NIPDAU	Level-1-260C-UNLIM	-40 to 85	TA13	Samples
TL431AIDBZT	ACTIVE	SOT-23	DBZ	3	250	RoHS & Green	NIPDAU SN	Level-1-260C-UNLIM	-40 to 85	(T3AG, TA13, TAIS, TAIU)	Samples
TL431AIDBZTG4	ACTIVE	SOT-23	DBZ	3	250	RoHS & Green	NIPDAU	Level-1-260C-UNLIM	-40 to 85	TA13	Samples
TL431AIDCKR	ACTIVE	SC70	DCK	6	3000	RoHS & Green	NIPDAU	Level-1-260C-UNLIM	-40 to 85	T5U	Samples
TL431AIDCKRE4	ACTIVE	SC70	DCK	6	3000	RoHS & Green	NIPDAU	Level-1-260C-UNLIM	-40 to 85	T5U	Samples
TL431AIDCKT	ACTIVE	SC70	DCK	6	250	RoHS & Green	NIPDAU	Level-1-260C-UNLIM	-40 to 85	T5U	Samples

Orderable Device	Status (1)	Package Type	Package Drawing	Pins	Package Qty	Eco Plan (2)	Lead finish/ Ball material (6)	MSL Peak Temp (3)	Op Temp (°C)	Device Marking (4/5)	Samples
TL431AIDG4	ACTIVE	SOIC	D	8	75	RoHS & Green	NIPDAU	Level-1-260C-UNLIM	-40 to 85	431AI	Samples
TL431AIDR	ACTIVE	SOIC	D	8	2500	RoHS & Green	NIPDAU SN	Level-1-260C-UNLIM	-40 to 85	431AI	Samples
TL431AIDRG4	ACTIVE	SOIC	D	8	2500	RoHS & Green	NIPDAU	Level-1-260C-UNLIM	-40 to 85	431AI	Samples
TL431AILP	ACTIVE	TO-92	LP	3	1000	RoHS & Green	SN	N / A for Pkg Type	-40 to 85	TL431AI	Samples
TL431AILPE3	ACTIVE	TO-92	LP	3	1000	RoHS & Green	SN	N / A for Pkg Type	-40 to 85	TL431AI	Samples
TL431AILPM	ACTIVE	TO-92	LP	3	2000	RoHS & Green	SN	N / A for Pkg Type	-40 to 85	TL431AI	Samples
TL431AILPME3	ACTIVE	TO-92	LP	3	2000	RoHS & Green	SN	N / A for Pkg Type	-40 to 85	TL431AI	Samples
TL431AILPR	ACTIVE	TO-92	LP	3	2000	RoHS & Green	SN	N / A for Pkg Type	-40 to 85	TL431AI	Samples
TL431AILPRE3	ACTIVE	TO-92	LP	3	2000	RoHS & Green	SN	N / A for Pkg Type	-40 to 85	TL431AI	Samples
TL431AIP	ACTIVE	PDIP	P	8	50	RoHS & Green	NIPDAU	N / A for Pkg Type	-40 to 85	TL431AIP	Samples
TL431AIP E4	ACTIVE	PDIP	P	8	50	RoHS & Green	NIPDAU	N / A for Pkg Type	-40 to 85	TL431AIP	Samples
TL431AIPK	ACTIVE	SOT-89	PK	3	1000	RoHS & Green	SN	Level-2-260C-1 YEAR	-40 to 85	4B	Samples
TL431AIPKG3	ACTIVE	SOT-89	PK	3	1000	RoHS & Green	SN	Level-2-260C-1 YEAR	-40 to 85	4B	Samples
TL431AQDBVR	ACTIVE	SOT-23	DBV	5	3000	RoHS & Green	NIPDAU SN	Level-1-260C-UNLIM	-40 to 125	(TAQG, TAQJ, TAQU)	Samples
TL431AQDBVT	ACTIVE	SOT-23	DBV	5	250	RoHS & Green	NIPDAU SN	Level-1-260C-UNLIM	-40 to 125	(TAQG, TAQJ, TAQU)	Samples
TL431AQDBZR	ACTIVE	SOT-23	DBZ	3	3000	RoHS & Green	NIPDAUAG SN	Level-1-260C-UNLIM	-40 to 125	(TAQ3, TAQG, TAQS, TAQU)	Samples
TL431AQDBZRG4	ACTIVE	SOT-23	DBZ	3	3000	RoHS & Green	NIPDAUAG	Level-1-260C-UNLIM	-40 to 125	TAQS	Samples
TL431AQDBZT	ACTIVE	SOT-23	DBZ	3	250	RoHS & Green	NIPDAUAG SN	Level-1-260C-UNLIM	-40 to 125	(TAQG, TAQS, TAQU)	Samples
TL431AQDBZTG4	ACTIVE	SOT-23	DBZ	3	250	RoHS & Green	NIPDAUAG	Level-1-260C-UNLIM	-40 to 125	TAQS	Samples
TL431AQDCKR	ACTIVE	SC70	DCK	6	3000	RoHS & Green	NIPDAU	Level-1-260C-UNLIM	-40 to 125	T7U	Samples

Orderable Device	Status (1)	Package Type	Package Drawing	Pins	Package Qty	Eco Plan (2)	Lead finish/ Ball material (6)	MSL Peak Temp (3)	Op Temp (°C)	Device Marking (4/5)	Samples
TL431AQDCKT	ACTIVE	SC70	DCK	6	250	RoHS & Green	NIPDAU	Level-1-260C-UNLIM	-40 to 125	T7U	Samples
TL431AQPCK	ACTIVE	SOT-89	PK	3	1000	RoHS & Green	SN	Level-2-260C-1 YEAR	-40 to 125	4D	Samples
TL431AQPCKG3	ACTIVE	SOT-89	PK	3	1000	RoHS & Green	SN	Level-2-260C-1 YEAR	-40 to 125	4D	Samples
TL431BCD	ACTIVE	SOIC	D	8	75	RoHS & Green	NIPDAU	Level-1-260C-UNLIM	0 to 70	T431B	Samples
TL431BCDBVR	ACTIVE	SOT-23	DBV	5	3000	RoHS & Green	NIPDAU SN	Level-1-260C-UNLIM	0 to 70	(T3GG, T3GJ, T3GU)	Samples
TL431BCDBVT	ACTIVE	SOT-23	DBV	5	250	RoHS & Green	NIPDAU SN	Level-1-260C-UNLIM	0 to 70	(T3GG, T3GJ, T3GU)	Samples
TL431BCDBVTG4	ACTIVE	SOT-23	DBV	5	250	RoHS & Green	NIPDAU	Level-1-260C-UNLIM	0 to 70	T3GG	Samples
TL431BCDBZR	ACTIVE	SOT-23	DBZ	3	3000	RoHS & Green	NIPDAU SN	Level-1-260C-UNLIM	0 to 70	(T3G3, T3GG, T3GS, T3GU)	Samples
TL431BCDBZRG4	ACTIVE	SOT-23	DBZ	3	3000	RoHS & Green	NIPDAU	Level-1-260C-UNLIM	0 to 70	T3G3	Samples
TL431BCDBZT	ACTIVE	SOT-23	DBZ	3	250	RoHS & Green	NIPDAU SN	Level-1-260C-UNLIM	0 to 70	(T3G3, T3GG, T3GS, T3GU)	Samples
TL431BCDBZTG4	ACTIVE	SOT-23	DBZ	3	250	RoHS & Green	NIPDAU	Level-1-260C-UNLIM	0 to 70	T3G3	Samples
TL431BCDCKR	ACTIVE	SC70	DCK	6	3000	RoHS & Green	NIPDAU	Level-1-260C-UNLIM	0 to 70	T2U	Samples
TL431BCDCKT	ACTIVE	SC70	DCK	6	250	RoHS & Green	NIPDAU	Level-1-260C-UNLIM	0 to 70	T2U	Samples
TL431BCDE4	ACTIVE	SOIC	D	8	75	RoHS & Green	NIPDAU	Level-1-260C-UNLIM	0 to 70	T431B	Samples
TL431BCDR	ACTIVE	SOIC	D	8	2500	RoHS & Green	NIPDAU	Level-1-260C-UNLIM	0 to 70	T431B	Samples
TL431BCDRG4	ACTIVE	SOIC	D	8	2500	TBD	Call TI	Call TI	0 to 70		Samples
TL431BCLP	ACTIVE	TO-92	LP	3	1000	RoHS & Green	SN	N / A for Pkg Type	0 to 70	T431B	Samples
TL431BCLPE3	ACTIVE	TO-92	LP	3	1000	RoHS & Green	SN	N / A for Pkg Type	0 to 70	T431B	Samples
TL431BCLPR	ACTIVE	TO-92	LP	3	2000	RoHS & Green	SN	N / A for Pkg Type	0 to 70	T431B	Samples
TL431BCP	ACTIVE	PDIP	P	8	50	RoHS & Green	NIPDAU	N / A for Pkg Type	0 to 70	TL431BCP	Samples

Orderable Device	Status (1)	Package Type	Package Drawing	Pins	Package Qty	Eco Plan (2)	Lead finish/ Ball material (6)	MSL Peak Temp (3)	Op Temp (°C)	Device Marking (4/5)	Samples
TL431BCPK	ACTIVE	SOT-89	PK	3	1000	RoHS & Green	SN	Level-2-260C-1 YEAR	0 to 70	4C	Samples
TL431BCPKG3	ACTIVE	SOT-89	PK	3	1000	RoHS & Green	SN	Level-2-260C-1 YEAR	0 to 70	4C	Samples
TL431BCPSR	ACTIVE	SO	PS	8	2000	RoHS & Green	NIPDAU	Level-1-260C-UNLIM	0 to 70	T431B	Samples
TL431BCPWR	ACTIVE	TSSOP	PW	8	2000	RoHS & Green	NIPDAU	Level-1-260C-UNLIM	0 to 70	T431B	Samples
TL431BID	ACTIVE	SOIC	D	8	75	RoHS & Green	NIPDAU	Level-1-260C-UNLIM	-40 to 85	Z431B	Samples
TL431BIDBVR	ACTIVE	SOT-23	DBV	5	3000	RoHS & Green	NIPDAU SN	Level-1-260C-UNLIM	-40 to 85	(T3FG, T3FJ, T3FU)	Samples
TL431BIDBVT	ACTIVE	SOT-23	DBV	5	250	RoHS & Green	NIPDAU SN	Level-1-260C-UNLIM	-40 to 85	(T3FG, T3FJ, T3FU)	Samples
TL431BIDBVTG4	ACTIVE	SOT-23	DBV	5	250	RoHS & Green	NIPDAU	Level-1-260C-UNLIM	-40 to 85	T3FG	Samples
TL431BIDBZR	ACTIVE	SOT-23	DBZ	3	3000	RoHS & Green	NIPDAU SN	Level-1-260C-UNLIM	-40 to 85	(T3F3, T3FG, T3FS, T3FU)	Samples
TL431BIDBZRG4	ACTIVE	SOT-23	DBZ	3	3000	RoHS & Green	NIPDAU	Level-1-260C-UNLIM	-40 to 85	T3F3	Samples
TL431BIDBZT	ACTIVE	SOT-23	DBZ	3	250	RoHS & Green	NIPDAU SN NIPDAUAG	Level-1-260C-UNLIM	-40 to 85	(T3F3, T3FG, T3FS, T3FU)	Samples
TL431BIDBZTG4	ACTIVE	SOT-23	DBZ	3	250	RoHS & Green	NIPDAU	Level-1-260C-UNLIM	-40 to 85	T3F3	Samples
TL431BIDCKR	ACTIVE	SC70	DCK	6	3000	RoHS & Green	NIPDAU	Level-1-260C-UNLIM	-40 to 85	T3U	Samples
TL431BIDCKT	ACTIVE	SC70	DCK	6	250	RoHS & Green	NIPDAU	Level-1-260C-UNLIM	-40 to 85	T3U	Samples
TL431BIDE4	ACTIVE	SOIC	D	8	75	RoHS & Green	NIPDAU	Level-1-260C-UNLIM	-40 to 85	Z431B	Samples
TL431BIDG4	ACTIVE	SOIC	D	8	75	RoHS & Green	NIPDAU	Level-1-260C-UNLIM	-40 to 85	Z431B	Samples
TL431BIDR	ACTIVE	SOIC	D	8	2500	RoHS & Green	NIPDAU SN	Level-1-260C-UNLIM	-40 to 85	Z431B	Samples
TL431BIDRE4	ACTIVE	SOIC	D	8	2500	RoHS & Green	NIPDAU	Level-1-260C-UNLIM	-40 to 85	Z431B	Samples
TL431BIDRG4	ACTIVE	SOIC	D	8	2500	RoHS & Green	NIPDAU	Level-1-260C-UNLIM	-40 to 85	Z431B	Samples
TL431BILP	ACTIVE	TO-92	LP	3	1000	RoHS & Green	SN	N / A for Pkg Type	-40 to 85	Z431B	Samples

Orderable Device	Status (1)	Package Type	Package Drawing	Pins	Package Qty	Eco Plan (2)	Lead finish/ Ball material (6)	MSL Peak Temp (3)	Op Temp (°C)	Device Marking (4/5)	Samples
TL431BILPE3	ACTIVE	TO-92	LP	3	1000	RoHS & Green	SN	N / A for Pkg Type	-40 to 85	Z431B	Samples
TL431BILPR	ACTIVE	TO-92	LP	3	2000	RoHS & Green	SN	N / A for Pkg Type	-40 to 85	Z431B	Samples
TL431BILPRE3	ACTIVE	TO-92	LP	3	2000	RoHS & Green	SN	N / A for Pkg Type	-40 to 85	Z431B	Samples
TL431BIP	ACTIVE	PDIP	P	8	50	RoHS & Green	NIPDAU	N / A for Pkg Type	-40 to 85	TL431BIP	Samples
TL431BIPK	ACTIVE	SOT-89	PK	3	1000	RoHS & Green	SN	Level-2-260C-1 YEAR	-40 to 85	4I	Samples
TL431BIPKG3	ACTIVE	SOT-89	PK	3	1000	RoHS & Green	SN	Level-2-260C-1 YEAR	-40 to 85	4I	Samples
TL431BQD	ACTIVE	SOIC	D	8	75	RoHS & Green	NIPDAU	Level-1-260C-UNLIM	-40 to 125	T431BQ	Samples
TL431BQDBVR	ACTIVE	SOT-23	DBV	5	3000	RoHS & Green	NIPDAU SN	Level-1-260C-UNLIM	-40 to 125	(T3HJ, T3HU)	Samples
TL431BQDBVRG4	ACTIVE	SOT-23	DBV	5	3000	RoHS & Green	NIPDAU	Level-1-260C-UNLIM	-40 to 125	(T3HJ, T3HU)	Samples
TL431BQDBVT	ACTIVE	SOT-23	DBV	5	250	RoHS & Green	NIPDAU SN	Level-1-260C-UNLIM	-40 to 125	(T3HJ, T3HU)	Samples
TL431BQDBZR	ACTIVE	SOT-23	DBZ	3	3000	RoHS & Green	NIPDAU SN NIPDAUAG	Level-1-260C-UNLIM	-40 to 125	(T3H3, T3HG, T3HS, T3HU)	Samples
TL431BQDBZRG4	ACTIVE	SOT-23	DBZ	3	3000	RoHS & Green	NIPDAUAG	Level-1-260C-UNLIM	-40 to 125	T3HS	Samples
TL431BQDBZT	ACTIVE	SOT-23	DBZ	3	250	RoHS & Green	NIPDAUAG SN	Level-1-260C-UNLIM	-40 to 125	(T3HG, T3HS, T3HU)	Samples
TL431BQDBZTG4	ACTIVE	SOT-23	DBZ	3	250	RoHS & Green	NIPDAUAG	Level-1-260C-UNLIM	-40 to 125	T3HS	Samples
TL431BQDCKR	ACTIVE	SC70	DCK	6	3000	RoHS & Green	NIPDAU	Level-1-260C-UNLIM	-40 to 125	T8U	Samples
TL431BQDCKT	ACTIVE	SC70	DCK	6	250	RoHS & Green	NIPDAU	Level-1-260C-UNLIM	-40 to 125	T8U	Samples
TL431BQDE4	ACTIVE	SOIC	D	8	75	RoHS & Green	NIPDAU	Level-1-260C-UNLIM	-40 to 125	T431BQ	Samples
TL431BQDR	ACTIVE	SOIC	D	8	2500	RoHS & Green	NIPDAU	Level-1-260C-UNLIM	-40 to 125	T431BQ	Samples
TL431BQDRG4	ACTIVE	SOIC	D	8	2500	RoHS & Green	NIPDAU	Level-1-260C-UNLIM	-40 to 125	T431BQ	Samples
TL431BQLP	ACTIVE	TO-92	LP	3	1000	RoHS & Green	SN	N / A for Pkg Type	-40 to 125	T431BQ	Samples
TL431BQLPM	ACTIVE	TO-92	LP	3	2000	RoHS & Green	SN	N / A for Pkg Type	-40 to 125	T431BQ	Samples

Orderable Device	Status (1)	Package Type	Package Drawing	Pins	Package Qty	Eco Plan (2)	Lead finish/ Ball material (6)	MSL Peak Temp (3)	Op Temp (°C)	Device Marking (4/5)	Samples
TL431BQLPME3	ACTIVE	TO-92	LP	3	2000	RoHS & Green	SN	N / A for Pkg Type	-40 to 125	T431BQ	Samples
TL431BQLPR	ACTIVE	TO-92	LP	3	2000	RoHS & Green	SN	N / A for Pkg Type	-40 to 125	T431BQ	Samples
TL431BQLPRE3	ACTIVE	TO-92	LP	3	2000	RoHS & Green	SN	N / A for Pkg Type	-40 to 125	T431BQ	Samples
TL431BQPK	ACTIVE	SOT-89	PK	3	1000	RoHS & Green	SN	Level-2-260C-1 YEAR	-40 to 125	3H	Samples
TL431BQPKG3	ACTIVE	SOT-89	PK	3	1000	RoHS & Green	SN	Level-2-260C-1 YEAR	-40 to 125	3H	Samples
TL431CD	ACTIVE	SOIC	D	8	75	RoHS & Green	NIPDAU	Level-1-260C-UNLIM	0 to 70	TL431C	Samples
TL431CDBVR	ACTIVE	SOT-23	DBV	5	3000	RoHS & Green	NIPDAU SN	Level-1-260C-UNLIM	0 to 70	(T3CG, T3CJ, T3CS)	Samples
TL431CDBVT	ACTIVE	SOT-23	DBV	5	250	RoHS & Green	NIPDAU SN	Level-1-260C-UNLIM	0 to 70	(T3CG, T3CJ, T3CS)	Samples
TL431CDBVTG4	ACTIVE	SOT-23	DBV	5	250	RoHS & Green	NIPDAU	Level-1-260C-UNLIM	0 to 70	T3CG	Samples
TL431CDBZR	ACTIVE	SOT-23	DBZ	3	3000	RoHS & Green	NIPDAU SN	Level-1-260C-UNLIM	0 to 70	(T3C3, T3CG, T3CS, T3CU)	Samples
TL431CDBZRG4	ACTIVE	SOT-23	DBZ	3	3000	RoHS & Green	NIPDAU	Level-1-260C-UNLIM	0 to 70	T3C3	Samples
TL431CDBZT	ACTIVE	SOT-23	DBZ	3	250	RoHS & Green	NIPDAUAG SN	Level-1-260C-UNLIM	0 to 70	(T3CG, T3CS, T3CU)	Samples
TL431CDBZTG4	ACTIVE	SOT-23	DBZ	3	250	RoHS & Green	NIPDAUAG	Level-1-260C-UNLIM	0 to 70	T3CS	Samples
TL431CDE4	ACTIVE	SOIC	D	8	75	RoHS & Green	NIPDAU	Level-1-260C-UNLIM	0 to 70	TL431C	Samples
TL431CDG4	ACTIVE	SOIC	D	8	75	RoHS & Green	NIPDAU	Level-1-260C-UNLIM	0 to 70	TL431C	Samples
TL431CDR	ACTIVE	SOIC	D	8	2500	RoHS & Green	NIPDAU SN	Level-1-260C-UNLIM	0 to 70	TL431C	Samples
TL431CDRG4	ACTIVE	SOIC	D	8	2500	RoHS & Green	NIPDAU	Level-1-260C-UNLIM	0 to 70	TL431C	Samples
TL431CLP	ACTIVE	TO-92	LP	3	1000	RoHS & Green	SN	N / A for Pkg Type	0 to 70	TL431C	Samples
TL431CLPE3	ACTIVE	TO-92	LP	3	1000	RoHS & Green	SN	N / A for Pkg Type	0 to 70	TL431C	Samples
TL431CLPM	ACTIVE	TO-92	LP	3	2000	RoHS & Green	SN	N / A for Pkg Type	0 to 70	TL431C	Samples

Orderable Device	Status (1)	Package Type	Package Drawing	Pins	Package Qty	Eco Plan (2)	Lead finish/ Ball material (6)	MSL Peak Temp (3)	Op Temp (°C)	Device Marking (4/5)	Samples
TL431CLPME3	ACTIVE	TO-92	LP	3	2000	RoHS & Green	SN	N / A for Pkg Type	0 to 70	TL431C	Samples
TL431CLPR	ACTIVE	TO-92	LP	3	2000	RoHS & Green	SN	N / A for Pkg Type	0 to 70	TL431C	Samples
TL431CLPRE3	ACTIVE	TO-92	LP	3	2000	RoHS & Green	SN	N / A for Pkg Type	0 to 70	TL431C	Samples
TL431CP	ACTIVE	PDIP	P	8	50	RoHS & Green	NIPDAU	N / A for Pkg Type	0 to 70	TL431CP	Samples
TL431CPE4	ACTIVE	PDIP	P	8	50	RoHS & Green	NIPDAU	N / A for Pkg Type	0 to 70	TL431CP	Samples
TL431CPK	ACTIVE	SOT-89	PK	3	1000	RoHS & Green	SN	Level-2-260C-1 YEAR	0 to 70	43	Samples
TL431CPKE6	ACTIVE	SOT-89	PK	3	1000	RoHS & Non-Green	SNBI	Level-1-260C-UNLIM	0 to 70	43	Samples
TL431CPKG3	ACTIVE	SOT-89	PK	3	1000	RoHS & Green	SN	Level-2-260C-1 YEAR	0 to 70	43	Samples
TL431CPSR	ACTIVE	SO	PS	8	2000	RoHS & Green	NIPDAU	Level-1-260C-UNLIM	0 to 70	T431	Samples
TL431CPSRG4	ACTIVE	SO	PS	8	2000	RoHS & Green	NIPDAU	Level-1-260C-UNLIM	0 to 70	T431	Samples
TL431CPWR	ACTIVE	TSSOP	PW	8	2000	RoHS & Green	NIPDAU	Level-1-260C-UNLIM	0 to 70	T431	Samples
TL431ID	ACTIVE	SOIC	D	8	75	RoHS & Green	NIPDAU	Level-1-260C-UNLIM	-40 to 85	TL431I	Samples
TL431IDBVR	ACTIVE	SOT-23	DBV	5	3000	RoHS & Green	NIPDAU SN	Level-1-260C-UNLIM	-40 to 85	(T3IG, T3IJ, T3IS)	Samples
TL431IDBPRE4	ACTIVE	SOT-23	DBV	5	3000	RoHS & Green	NIPDAU	Level-1-260C-UNLIM	-40 to 85	T3IG	Samples
TL431IDBVRG4	ACTIVE	SOT-23	DBV	5	3000	RoHS & Green	NIPDAU	Level-1-260C-UNLIM	-40 to 85	T3IG	Samples
TL431IDBVT	ACTIVE	SOT-23	DBV	5	250	RoHS & Green	NIPDAU SN	Level-1-260C-UNLIM	-40 to 85	(T3IG, T3IJ, T3IU)	Samples
TL431IDBZR	ACTIVE	SOT-23	DBZ	3	3000	RoHS & Green	NIPDAUAG SN	Level-1-260C-UNLIM	-40 to 85	(T3I3, T3IG, T3IS, T3IU)	Samples
TL431IDBZRG4	ACTIVE	SOT-23	DBZ	3	3000	RoHS & Green	NIPDAUAG	Level-1-260C-UNLIM	-40 to 85	T3IS	Samples
TL431IDBZT	ACTIVE	SOT-23	DBZ	3	250	RoHS & Green	NIPDAUAG SN	Level-1-260C-UNLIM	-40 to 85	(T3IG, T3IS, T3IU)	Samples
TL431IDBZTG4	ACTIVE	SOT-23	DBZ	3	250	RoHS & Green	NIPDAUAG	Level-1-260C-UNLIM	-40 to 85	T3IS	Samples

Orderable Device	Status (1)	Package Type	Package Drawing	Pins	Package Qty	Eco Plan (2)	Lead finish/ Ball material (6)	MSL Peak Temp (3)	Op Temp (°C)	Device Marking (4/5)	Samples
TL431IDG4	ACTIVE	SOIC	D	8	75	RoHS & Green	NIPDAU	Level-1-260C-UNLIM	-40 to 85	TL431I	Samples
TL431IDR	ACTIVE	SOIC	D	8	2500	RoHS & Green	NIPDAU SN	Level-1-260C-UNLIM	-40 to 85	TL431I	Samples
TL431IDRE4	ACTIVE	SOIC	D	8	2500	TBD	Call TI	Call TI	-40 to 85		Samples
TL431IDRG4	ACTIVE	SOIC	D	8	2500	RoHS & Green	NIPDAU	Level-1-260C-UNLIM	-40 to 85	TL431I	Samples
TL431ILP	ACTIVE	TO-92	LP	3	1000	RoHS & Green	SN	N / A for Pkg Type	-40 to 85	TL431I	Samples
TL431ILPE3	ACTIVE	TO-92	LP	3	1000	RoHS & Green	SN	N / A for Pkg Type	-40 to 85	TL431I	Samples
TL431ILPR	ACTIVE	TO-92	LP	3	2000	RoHS & Green	SN	N / A for Pkg Type	-40 to 85	TL431I	Samples
TL431ILPRE3	ACTIVE	TO-92	LP	3	2000	RoHS & Green	SN	N / A for Pkg Type	-40 to 85	TL431I	Samples
TL431IP	ACTIVE	PDIP	P	8	50	RoHS & Green	NIPDAU	N / A for Pkg Type	-40 to 85	TL431IP	Samples
TL431IPE4	ACTIVE	PDIP	P	8	50	RoHS & Green	NIPDAU	N / A for Pkg Type	-40 to 85	TL431IP	Samples
TL431IPK	ACTIVE	SOT-89	PK	3	1000	RoHS & Green	SN	Level-2-260C-1 YEAR	-40 to 85	3I	Samples
TL431IPKG3	ACTIVE	SOT-89	PK	3	1000	RoHS & Green	SN	Level-2-260C-1 YEAR	-40 to 85	3I	Samples
TL431IQD	ACTIVE	SOIC	D	8	75	RoHS & Green	NIPDAU	Level-1-260C-UNLIM	-40 to 125	T431Q	Samples
TL431QDBVR	ACTIVE	SOT-23	DBV	5	3000	RoHS & Green	NIPDAU SN	Level-1-260C-UNLIM	-40 to 125	(T3QG, T3QJ, T3QU)	Samples
TL431QDBVRG4	ACTIVE	SOT-23	DBV	5	3000	RoHS & Green	NIPDAU	Level-1-260C-UNLIM	-40 to 125	T3QG	Samples
TL431QDBVT	ACTIVE	SOT-23	DBV	5	250	RoHS & Green	NIPDAU SN	Level-1-260C-UNLIM	-40 to 125	(T3QG, T3QJ, T3QU)	Samples
TL431QDBZR	ACTIVE	SOT-23	DBZ	3	3000	RoHS & Green	NIPDAUAG SN	Level-1-260C-UNLIM	-40 to 125	(T3Q3, T3QG, T3QS, T3QU)	Samples
TL431QDBZRG4	ACTIVE	SOT-23	DBZ	3	3000	RoHS & Green	NIPDAUAG	Level-1-260C-UNLIM	-40 to 125	T3QS	Samples
TL431QDBZT	ACTIVE	SOT-23	DBZ	3	250	RoHS & Green	NIPDAUAG SN	Level-1-260C-UNLIM	-40 to 125	(T3QG, T3QS, T3QU)	Samples
TL431QDBZTG4	ACTIVE	SOT-23	DBZ	3	250	RoHS & Green	NIPDAUAG	Level-1-260C-UNLIM	-40 to 125	T3QS	Samples

Orderable Device	Status (1)	Package Type	Package Drawing	Pins	Package Qty	Eco Plan (2)	Lead finish/ Ball material (6)	MSL Peak Temp (3)	Op Temp (°C)	Device Marking (4/5)	Samples
TL431QDCKR	ACTIVE	SC70	DCK	6	3000	RoHS & Green	NIPDAU	Level-1-260C-UNLIM	-40 to 125	T6U	Samples
TL431QDCKT	ACTIVE	SC70	DCK	6	250	RoHS & Green	NIPDAU	Level-1-260C-UNLIM	-40 to 125	T6U	Samples
TL431QDR	ACTIVE	SOIC	D	8	2500	RoHS & Green	NIPDAU	Level-1-260C-UNLIM	-40 to 125	T431Q	Samples
TL431QPK	ACTIVE	SOT-89	PK	3	1000	RoHS & Green	SN	Level-2-260C-1 YEAR	-40 to 125	3Q	Samples
TL431QPKG3	ACTIVE	SOT-89	PK	3	1000	RoHS & Green	SN	Level-2-260C-1 YEAR	-40 to 125	3Q	Samples
TL432ACDBVR	ACTIVE	SOT-23	DBV	5	3000	RoHS & Green	NIPDAU SN	Level-1-260C-UNLIM	0 to 70	(T4BG, T4BJ, T4BU)	Samples
TL432ACDBZR	ACTIVE	SOT-23	DBZ	3	3000	RoHS & Green	NIPDAUAG SN	Level-1-260C-UNLIM	0 to 70	(T4B3, T4BG, T4BS, T4BU)	Samples
TL432ACDBZRG4	ACTIVE	SOT-23	DBZ	3	3000	RoHS & Green	NIPDAUAG	Level-1-260C-UNLIM	0 to 70	T4BS	Samples
TL432ACDBZT	ACTIVE	SOT-23	DBZ	3	250	RoHS & Green	NIPDAUAG SN	Level-1-260C-UNLIM	0 to 70	(T4BG, T4BS, T4BU)	Samples
TL432ACDBZTG4	ACTIVE	SOT-23	DBZ	3	250	RoHS & Green	NIPDAUAG	Level-1-260C-UNLIM	0 to 70	T4BS	Samples
TL432AIDBVR	ACTIVE	SOT-23	DBV	5	3000	RoHS & Green	NIPDAU SN	Level-1-260C-UNLIM	-40 to 85	(T4AG, T4AJ, T4AU)	Samples
TL432AIDBZR	ACTIVE	SOT-23	DBZ	3	3000	RoHS & Green	NIPDAU SN	Level-1-260C-UNLIM	-40 to 85	(T4A3, T4AG, T4AS, T4AU)	Samples
TL432AIDBZRG4	ACTIVE	SOT-23	DBZ	3	3000	RoHS & Green	NIPDAU	Level-1-260C-UNLIM	-40 to 85	T4A3	Samples
TL432AIDBZT	ACTIVE	SOT-23	DBZ	3	250	RoHS & Green	NIPDAU SN	Level-1-260C-UNLIM	-40 to 85	(T4A3, T4AG, T4AS, T4AU)	Samples
TL432AIDBZTG4	ACTIVE	SOT-23	DBZ	3	250	RoHS & Green	NIPDAU	Level-1-260C-UNLIM	-40 to 85	T4A3	Samples
TL432AIPK	ACTIVE	SOT-89	PK	3	1000	RoHS & Green	SN	Level-2-260C-1 YEAR	-40 to 85	2E	Samples
TL432AQDBVR	ACTIVE	SOT-23	DBV	5	3000	RoHS & Green	NIPDAU SN	Level-1-260C-UNLIM	-40 to 125	(T4DJ, T4DU)	Samples
TL432AQDBVT	ACTIVE	SOT-23	DBV	5	250	RoHS & Green	NIPDAU SN	Level-1-260C-UNLIM	-40 to 125	(T4DJ, T4DU)	Samples
TL432AQDBZR	ACTIVE	SOT-23	DBZ	3	3000	RoHS & Green	NIPDAUAG SN	Level-1-260C-UNLIM	-40 to 125	(T4D3, T4DG, T4DS, T4DU)	Samples
TL432AQDBZRG4	ACTIVE	SOT-23	DBZ	3	3000	RoHS & Green	NIPDAUAG	Level-1-260C-UNLIM	-40 to 125	T4DS	Samples

Orderable Device	Status (1)	Package Type	Package Drawing	Pins	Package Qty	Eco Plan (2)	Lead finish/ Ball material (6)	MSL Peak Temp (3)	Op Temp (°C)	Device Marking (4/5)	Samples
TL432AQDBZT	ACTIVE	SOT-23	DBZ	3	250	RoHS & Green	NIPDAUAG SN	Level-1-260C-UNLIM	-40 to 125	(T4DG, T4DS, T4DU)	Samples
TL432AQDBZTG4	ACTIVE	SOT-23	DBZ	3	250	RoHS & Green	NIPDAUAG	Level-1-260C-UNLIM	-40 to 125	T4DS	Samples
TL432AQP	ACTIVE	SOT-89	PK	3	1000	RoHS & Green	SN	Level-2-260C-1 YEAR	-40 to 125	2F	Samples
TL432AQP3	ACTIVE	SOT-89	PK	3	1000	RoHS & Green	SN	Level-2-260C-1 YEAR	-40 to 125	2F	Samples
TL432BCDBVR	ACTIVE	SOT-23	DBV	5	3000	RoHS & Green	NIPDAU SN	Level-1-260C-UNLIM	0 to 70	(TBCJ, TBCU)	Samples
TL432BCDBZR	ACTIVE	SOT-23	DBZ	3	3000	RoHS & Green	NIPDAUAG SN	Level-1-260C-UNLIM	0 to 70	(TBCG, TBCS, TBCU)	Samples
TL432BCDBZRG4	ACTIVE	SOT-23	DBZ	3	3000	RoHS & Green	NIPDAUAG	Level-1-260C-UNLIM	0 to 70	TBCS	Samples
TL432BCDBZT	ACTIVE	SOT-23	DBZ	3	250	RoHS & Green	NIPDAUAG SN	Level-1-260C-UNLIM	0 to 70	(TBCG, TBCS, TBCU)	Samples
TL432BCDBZTG4	ACTIVE	SOT-23	DBZ	3	250	RoHS & Green	NIPDAUAG	Level-1-260C-UNLIM	0 to 70	TBCS	Samples
TL432BCPK	ACTIVE	SOT-89	PK	3	1000	RoHS & Green	SN	Level-2-260C-1 YEAR	0 to 70	2G	Samples
TL432BIDBZR	ACTIVE	SOT-23	DBZ	3	3000	RoHS & Green	NIPDAU SN	Level-1-260C-UNLIM	-40 to 85	(T4F3, T4FG, T4FS, T4FU)	Samples
TL432BIDBZRG4	ACTIVE	SOT-23	DBZ	3	3000	RoHS & Green	NIPDAU	Level-1-260C-UNLIM	-40 to 85	T4F3	Samples
TL432BIDBZT	ACTIVE	SOT-23	DBZ	3	250	RoHS & Green	NIPDAU SN	Level-1-260C-UNLIM	-40 to 85	(T4F3, T4FG, T4FS, T4FU)	Samples
TL432BIDBZTG4	ACTIVE	SOT-23	DBZ	3	250	RoHS & Green	NIPDAU	Level-1-260C-UNLIM	-40 to 85	T4F3	Samples
TL432BIPK	ACTIVE	SOT-89	PK	3	1000	RoHS & Green	SN	Level-2-260C-1 YEAR	-40 to 85	2H	Samples
TL432BQDBZR	ACTIVE	SOT-23	DBZ	3	3000	RoHS & Green	NIPDAU NIPDAUAG	Level-1-260C-UNLIM	-40 to 125	(T4H3, T4HS, T4HU)	Samples
TL432BQDBZRG4	ACTIVE	SOT-23	DBZ	3	3000	RoHS & Green	NIPDAU	Level-1-260C-UNLIM	-40 to 125	(T4H3, T4HS, T4HU)	Samples
TL432BQPK	ACTIVE	SOT-89	PK	3	1000	RoHS & Green	SN	Level-2-260C-1 YEAR	-40 to 125	2J	Samples
TL432CDBVR	ACTIVE	SOT-23	DBV	5	3000	RoHS & Green	NIPDAU SN	Level-1-260C-UNLIM	0 to 70	(T4CG, T4CJ, T4CU)	Samples

Orderable Device	Status (1)	Package Type	Package Drawing	Pins	Package Qty	Eco Plan (2)	Lead finish/ Ball material (6)	MSL Peak Temp (3)	Op Temp (°C)	Device Marking (4/5)	Samples
TL432CDBZR	ACTIVE	SOT-23	DBZ	3	3000	RoHS & Green	NIPDAUAG SN	Level-1-260C-UNLIM	0 to 70	(T4CG, T4CS, T4CU)	Samples
TL432CDBZRG4	ACTIVE	SOT-23	DBZ	3	3000	RoHS & Green	NIPDAUAG	Level-1-260C-UNLIM	0 to 70	T4CS	Samples
TL432CPK	ACTIVE	SOT-89	PK	3	1000	RoHS & Green	SN	Level-2-260C-1 YEAR	0 to 70	2A	Samples
TL432IDBVR	ACTIVE	SOT-23	DBV	5	3000	RoHS & Green	NIPDAU SN	Level-1-260C-UNLIM	-40 to 85	(T4IG, T4IJ, T4IU)	Samples
TL432IDBZR	ACTIVE	SOT-23	DBZ	3	3000	RoHS & Green	NIPDAUAG SN	Level-1-260C-UNLIM	-40 to 85	(T4IG, T4IS, T4IU)	Samples
TL432IDBZRG4	ACTIVE	SOT-23	DBZ	3	3000	RoHS & Green	NIPDAUAG	Level-1-260C-UNLIM	-40 to 85	T4IS	Samples
TL432IDBZT	ACTIVE	SOT-23	DBZ	3	250	RoHS & Green	NIPDAUAG SN	Level-1-260C-UNLIM	-40 to 85	(T4IG, T4IS, T4IU)	Samples
TL432IDBZTG4	ACTIVE	SOT-23	DBZ	3	250	RoHS & Green	NIPDAUAG	Level-1-260C-UNLIM	-40 to 85	T4IS	Samples
TL432IPK	ACTIVE	SOT-89	PK	3	1000	RoHS & Green	SN	Level-2-260C-1 YEAR	-40 to 85	2B	Samples
TL432QDBZR	ACTIVE	SOT-23	DBZ	3	3000	RoHS & Green	NIPDAUAG SN	Level-1-260C-UNLIM	-40 to 125	(T4QG, T4QS, T4QU)	Samples
TL432QDBZRG4	ACTIVE	SOT-23	DBZ	3	3000	RoHS & Green	NIPDAUAG	Level-1-260C-UNLIM	-40 to 125	T4QS	Samples
TL432QPK	ACTIVE	SOT-89	PK	3	1000	RoHS & Green	SN	Level-2-260C-1 YEAR	-40 to 125	2C	Samples
TL432QPKG3	ACTIVE	SOT-89	PK	3	1000	RoHS & Green	SN	Level-2-260C-1 YEAR	-40 to 125	2C	Samples

(1) The marketing status values are defined as follows:

ACTIVE: Product device recommended for new designs.

LIFEBUY: TI has announced that the device will be discontinued, and a lifetime-buy period is in effect.

NRND: Not recommended for new designs. Device is in production to support existing customers, but TI does not recommend using this part in a new design.

PREVIEW: Device has been announced but is not in production. Samples may or may not be available.

OBSELETE: TI has discontinued the production of the device.

(2) **RoHS:** TI defines "RoHS" to mean semiconductor products that are compliant with the current EU RoHS requirements for all 10 RoHS substances, including the requirement that RoHS substance do not exceed 0.1% by weight in homogeneous materials. Where designed to be soldered at high temperatures, "RoHS" products are suitable for use in specified lead-free processes. TI may reference these types of products as "Pb-Free".

RoHS Exempt: TI defines "RoHS Exempt" to mean products that contain lead but are compliant with EU RoHS pursuant to a specific EU RoHS exemption.

Green: TI defines "Green" to mean the content of Chlorine (Cl) and Bromine (Br) based flame retardants meet JS709B low halogen requirements of <=1000ppm threshold. Antimony trioxide based flame retardants must also meet the <=1000ppm threshold requirement.

- (3) MSL, Peak Temp. - The Moisture Sensitivity Level rating according to the JEDEC industry standard classifications, and peak solder temperature.
- (4) There may be additional marking, which relates to the logo, the lot trace code information, or the environmental category on the device.
- (5) Multiple Device Markings will be inside parentheses. Only one Device Marking contained in parentheses and separated by a "~" will appear on a device. If a line is indented then it is a continuation of the previous line and the two combined represent the entire Device Marking for that device.
- (6) Lead finish/Ball material - Orderable Devices may have multiple material finish options. Finish options are separated by a vertical ruled line. Lead finish/Ball material values may wrap to two lines if the finish value exceeds the maximum column width.

Important Information and Disclaimer:The information provided on this page represents TI's knowledge and belief as of the date that it is provided. TI bases its knowledge and belief on information provided by third parties, and makes no representation or warranty as to the accuracy of such information. Efforts are underway to better integrate information from third parties. TI has taken and continues to take reasonable steps to provide representative and accurate information but may not have conducted destructive testing or chemical analysis on incoming materials and chemicals. TI and TI suppliers consider certain information to be proprietary, and thus CAS numbers and other limited information may not be available for release.

In no event shall TI's liability arising out of such information exceed the total purchase price of the TI part(s) at issue in this document sold by TI to Customer on an annual basis.

OTHER QUALIFIED VERSIONS OF TL431, TL432 :

- Automotive : [TL431-Q1](#), [TL432-Q1](#)

NOTE: Qualified Version Definitions:

- Automotive - Q100 devices qualified for high-reliability automotive applications targeting zero defects

TAPE AND REEL INFORMATION

QUADRANT ASSIGNMENTS FOR PIN 1 ORIENTATION IN TAPE

*All dimensions are nominal

Device	Package Type	Package Drawing	Pins	SPQ	Reel Diameter (mm)	Reel Width W1 (mm)	A0 (mm)	B0 (mm)	K0 (mm)	P1 (mm)	W (mm)	Pin1 Quadrant
TL431ACDBVR	SOT-23	DBV	5	3000	178.0	9.0	3.3	3.2	1.4	4.0	8.0	Q3
TL431ACDBVR	SOT-23	DBV	5	3000	178.0	9.0	3.3	3.2	1.4	4.0	8.0	Q3
TL431ACDBVR	SOT-23	DBV	5	3000	180.0	8.4	3.23	3.17	1.37	4.0	8.0	Q3
TL431ACDBVRG4	SOT-23	DBV	5	3000	178.0	9.0	3.3	3.2	1.4	4.0	8.0	Q3
TL431ACDBVT	SOT-23	DBV	5	250	178.0	9.0	3.23	3.17	1.37	4.0	8.0	Q3
TL431ACDBVT	SOT-23	DBV	5	250	178.0	9.0	3.3	3.2	1.4	4.0	8.0	Q3
TL431ACDBZR	SOT-23	DBZ	3	3000	178.0	9.0	3.15	2.77	1.22	4.0	8.0	Q3
TL431ACDBZR	SOT-23	DBZ	3	3000	178.0	9.2	3.15	2.77	1.22	4.0	8.0	Q3
TL431ACDBZRG4	SOT-23	DBZ	3	3000	178.0	9.2	3.15	2.77	1.22	4.0	8.0	Q3
TL431ACDBZT	SOT-23	DBZ	3	250	178.0	9.0	3.15	2.77	1.22	4.0	8.0	Q3
TL431ACDBZT	SOT-23	DBZ	3	250	178.0	9.2	3.15	2.77	1.22	4.0	8.0	Q3
TL431ACDBZTG4	SOT-23	DBZ	3	250	178.0	9.2	3.15	2.77	1.22	4.0	8.0	Q3
TL431ACDCKR	SC70	DCK	6	3000	180.0	8.4	2.41	2.41	1.2	4.0	8.0	Q3
TL431ACDR	SOIC	D	8	2500	330.0	12.4	6.4	5.2	2.1	8.0	12.0	Q1
TL431ACDR	SOIC	D	8	2500	330.0	12.8	6.4	5.2	2.1	8.0	12.0	Q1
TL431ACDRG4	SOIC	D	8	2500	330.0	12.4	6.4	5.2	2.1	8.0	12.0	Q1

Device	Package Type	Package Drawing	Pins	SPQ	Reel Diameter (mm)	Reel Width W1 (mm)	A0 (mm)	B0 (mm)	K0 (mm)	P1 (mm)	W (mm)	Pin1 Quadrant
TL431ACPK	SOT-89	PK	3	1000	180.0	12.4	4.91	4.52	1.9	8.0	12.0	Q3
TL431ACPSR	SO	PS	8	2000	330.0	16.4	8.35	6.6	2.4	12.0	16.0	Q1
TL431ACPWR	TSSOP	PW	8	2000	330.0	12.4	7.0	3.6	1.6	8.0	12.0	Q1
TL431AIDBVR	SOT-23	DBV	5	3000	178.0	9.0	3.3	3.2	1.4	4.0	8.0	Q3
TL431AIDBVR	SOT-23	DBV	5	3000	180.0	8.4	3.23	3.17	1.37	4.0	8.0	Q3
TL431AIDBVR	SOT-23	DBV	5	3000	178.0	9.0	3.23	3.17	1.37	4.0	8.0	Q3
TL431AIDBVRG4	SOT-23	DBV	5	3000	178.0	9.0	3.23	3.17	1.37	4.0	8.0	Q3
TL431AIDBVT	SOT-23	DBV	5	250	178.0	9.0	3.23	3.17	1.37	4.0	8.0	Q3
TL431AIDBVT	SOT-23	DBV	5	250	178.0	9.0	3.3	3.2	1.4	4.0	8.0	Q3
TL431AIDBVTG4	SOT-23	DBV	5	250	178.0	9.0	3.23	3.17	1.37	4.0	8.0	Q3
TL431AIDBZR	SOT-23	DBZ	3	3000	178.0	9.2	3.15	2.77	1.22	4.0	8.0	Q3
TL431AIDBZR	SOT-23	DBZ	3	3000	178.0	9.0	3.15	2.77	1.22	4.0	8.0	Q3
TL431AIDBZRG4	SOT-23	DBZ	3	3000	178.0	9.2	3.15	2.77	1.22	4.0	8.0	Q3
TL431AIDBZT	SOT-23	DBZ	3	250	178.0	9.0	3.15	2.77	1.22	4.0	8.0	Q3
TL431AIDBZT	SOT-23	DBZ	3	250	178.0	9.2	3.15	2.77	1.22	4.0	8.0	Q3
TL431AIDBZTG4	SOT-23	DBZ	3	250	178.0	9.2	3.15	2.77	1.22	4.0	8.0	Q3
TL431AIDCKR	SC70	DCK	6	3000	179.0	8.4	2.2	2.5	1.2	4.0	8.0	Q3
TL431AIDCKT	SC70	DCK	6	250	179.0	8.4	2.2	2.5	1.2	4.0	8.0	Q3
TL431AIDR	SOIC	D	8	2500	330.0	12.4	6.4	5.2	2.1	8.0	12.0	Q1
TL431AIDR	SOIC	D	8	2500	330.0	12.8	6.4	5.2	2.1	8.0	12.0	Q1
TL431AIDRG4	SOIC	D	8	2500	330.0	12.4	6.4	5.2	2.1	8.0	12.0	Q1
TL431AIPK	SOT-89	PK	3	1000	180.0	12.4	4.91	4.52	1.9	8.0	12.0	Q3
TL431AQDBVR	SOT-23	DBV	5	3000	178.0	9.0	3.3	3.2	1.4	4.0	8.0	Q3
TL431AQDBVR	SOT-23	DBV	5	3000	178.0	9.0	3.23	3.17	1.37	4.0	8.0	Q3
TL431AQDBVT	SOT-23	DBV	5	250	178.0	9.0	3.3	3.2	1.4	4.0	8.0	Q3
TL431AQDBVT	SOT-23	DBV	5	250	178.0	9.0	3.3	3.2	1.4	4.0	8.0	Q3
TL431AQDBZR	SOT-23	DBZ	3	3000	178.0	9.0	3.15	2.77	1.22	4.0	8.0	Q3
TL431AQDBZR	SOT-23	DBZ	3	3000	180.0	8.4	3.15	2.77	1.22	4.0	8.0	Q3
TL431AQDBZRG4	SOT-23	DBZ	3	3000	180.0	8.4	3.15	2.77	1.22	4.0	8.0	Q3
TL431AQDBZT	SOT-23	DBZ	3	250	180.0	8.4	3.15	2.77	1.22	4.0	8.0	Q3
TL431AQDBZT	SOT-23	DBZ	3	250	178.0	9.0	3.15	2.77	1.22	4.0	8.0	Q3
TL431AQDBZTG4	SOT-23	DBZ	3	250	180.0	8.4	3.15	2.77	1.22	4.0	8.0	Q3
TL431AQDCKR	SC70	DCK	6	3000	179.0	8.4	2.2	2.5	1.2	4.0	8.0	Q3
TL431AQDCKT	SC70	DCK	6	250	179.0	8.4	2.2	2.5	1.2	4.0	8.0	Q3
TL431AQPK	SOT-89	PK	3	1000	180.0	12.4	4.91	4.52	1.9	8.0	12.0	Q3
TL431BCDBVR	SOT-23	DBV	5	3000	178.0	9.0	3.3	3.2	1.4	4.0	8.0	Q3
TL431BCDBVR	SOT-23	DBV	5	3000	178.0	9.0	3.23	3.17	1.37	4.0	8.0	Q3
TL431BCDBVT	SOT-23	DBV	5	250	178.0	9.0	3.23	3.17	1.37	4.0	8.0	Q3
TL431BCDBVT	SOT-23	DBV	5	250	178.0	9.0	3.3	3.2	1.4	4.0	8.0	Q3
TL431BCDBVTG4	SOT-23	DBV	5	250	178.0	9.0	3.23	3.17	1.37	4.0	8.0	Q3
TL431BCDBZR	SOT-23	DBZ	3	3000	178.0	9.0	3.15	2.77	1.22	4.0	8.0	Q3

Device	Package Type	Package Drawing	Pins	SPQ	Reel Diameter (mm)	Reel Width W1 (mm)	A0 (mm)	B0 (mm)	K0 (mm)	P1 (mm)	W (mm)	Pin1 Quadrant
TL431BCDBZR	SOT-23	DBZ	3	3000	178.0	9.2	3.15	2.77	1.22	4.0	8.0	Q3
TL431BCDBZRG4	SOT-23	DBZ	3	3000	178.0	9.2	3.15	2.77	1.22	4.0	8.0	Q3
TL431BCDBZT	SOT-23	DBZ	3	250	178.0	9.2	3.15	2.77	1.22	4.0	8.0	Q3
TL431BCDBZT	SOT-23	DBZ	3	250	178.0	9.0	3.15	2.77	1.22	4.0	8.0	Q3
TL431BCDBZTG4	SOT-23	DBZ	3	250	178.0	9.2	3.15	2.77	1.22	4.0	8.0	Q3
TL431BCDCKR	SC70	DCK	6	3000	179.0	8.4	2.2	2.5	1.2	4.0	8.0	Q3
TL431BCDCKT	SC70	DCK	6	250	179.0	8.4	2.2	2.5	1.2	4.0	8.0	Q3
TL431BCDR	SOIC	D	8	2500	330.0	12.4	6.4	5.2	2.1	8.0	12.0	Q1
TL431BCPK	SOT-89	PK	3	1000	180.0	12.4	4.91	4.52	1.9	8.0	12.0	Q3
TL431BCPSR	SO	PS	8	2000	330.0	16.4	8.35	6.6	2.4	12.0	16.0	Q1
TL431BCPWR	TSSOP	PW	8	2000	330.0	12.4	7.0	3.6	1.6	8.0	12.0	Q1
TL431BIDBVR	SOT-23	DBV	5	3000	178.0	9.0	3.23	3.17	1.37	4.0	8.0	Q3
TL431BIDBVR	SOT-23	DBV	5	3000	178.0	9.0	3.3	3.2	1.4	4.0	8.0	Q3
TL431BIDBVT	SOT-23	DBV	5	250	178.0	9.0	3.23	3.17	1.37	4.0	8.0	Q3
TL431BIDBVT	SOT-23	DBV	5	250	178.0	9.0	3.3	3.2	1.4	4.0	8.0	Q3
TL431BIDBVTG4	SOT-23	DBV	5	250	178.0	9.0	3.23	3.17	1.37	4.0	8.0	Q3
TL431BIDBZR	SOT-23	DBZ	3	3000	178.0	9.2	3.15	2.77	1.22	4.0	8.0	Q3
TL431BIDBZR	SOT-23	DBZ	3	3000	178.0	9.0	3.15	2.77	1.22	4.0	8.0	Q3
TL431BIDBZRG4	SOT-23	DBZ	3	3000	178.0	9.2	3.15	2.77	1.22	4.0	8.0	Q3
TL431BIDBZT	SOT-23	DBZ	3	250	178.0	9.0	3.15	2.77	1.22	4.0	8.0	Q3
TL431BIDBZT	SOT-23	DBZ	3	250	178.0	9.2	3.15	2.77	1.22	4.0	8.0	Q3
TL431BIDBZTG4	SOT-23	DBZ	3	250	178.0	9.2	3.15	2.77	1.22	4.0	8.0	Q3
TL431BIDCKR	SC70	DCK	6	3000	179.0	8.4	2.2	2.5	1.2	4.0	8.0	Q3
TL431BIDCKT	SC70	DCK	6	250	179.0	8.4	2.2	2.5	1.2	4.0	8.0	Q3
TL431BIDR	SOIC	D	8	2500	330.0	12.4	6.4	5.2	2.1	8.0	12.0	Q1
TL431BIDR	SOIC	D	8	2500	330.0	12.8	6.4	5.2	2.1	8.0	12.0	Q1
TL431BIDRG4	SOIC	D	8	2500	330.0	12.4	6.4	5.2	2.1	8.0	12.0	Q1
TL431BIPK	SOT-89	PK	3	1000	180.0	12.4	4.91	4.52	1.9	8.0	12.0	Q3
TL431BQDBVR	SOT-23	DBV	5	3000	178.0	9.0	3.3	3.2	1.4	4.0	8.0	Q3
TL431BQDBVR	SOT-23	DBV	5	3000	180.0	8.4	3.2	3.2	1.4	4.0	8.0	Q3
TL431BQDBVT	SOT-23	DBV	5	250	180.0	8.4	3.2	3.2	1.4	4.0	8.0	Q3
TL431BQDBVT	SOT-23	DBV	5	250	178.0	9.0	3.3	3.2	1.4	4.0	8.0	Q3
TL431BQDBZR	SOT-23	DBZ	3	3000	180.0	8.4	3.15	2.77	1.22	4.0	8.0	Q3
TL431BQDBZR	SOT-23	DBZ	3	3000	178.0	9.0	3.15	2.77	1.22	4.0	8.0	Q3
TL431BQDBZR	SOT-23	DBZ	3	3000	178.0	9.2	3.15	2.77	1.22	4.0	8.0	Q3
TL431BQDBZRG4	SOT-23	DBZ	3	3000	180.0	8.4	3.15	2.77	1.22	4.0	8.0	Q3
TL431BQDBZT	SOT-23	DBZ	3	250	180.0	8.4	3.15	2.77	1.22	4.0	8.0	Q3
TL431BQDBZT	SOT-23	DBZ	3	250	178.0	9.0	3.15	2.77	1.22	4.0	8.0	Q3
TL431BQDBZTG4	SOT-23	DBZ	3	250	180.0	8.4	3.15	2.77	1.22	4.0	8.0	Q3
TL431BQDCKR	SC70	DCK	6	3000	179.0	8.4	2.2	2.5	1.2	4.0	8.0	Q3
TL431BQDCKT	SC70	DCK	6	250	179.0	8.4	2.2	2.5	1.2	4.0	8.0	Q3

Device	Package Type	Package Drawing	Pins	SPQ	Reel Diameter (mm)	Reel Width W1 (mm)	A0 (mm)	B0 (mm)	K0 (mm)	P1 (mm)	W (mm)	Pin1 Quadrant
TL431BQDR	SOIC	D	8	2500	330.0	12.4	6.4	5.2	2.1	8.0	12.0	Q1
TL431CDBVR	SOT-23	DBV	5	3000	178.0	9.0	3.23	3.17	1.37	4.0	8.0	Q3
TL431CDBVR	SOT-23	DBV	5	3000	178.0	9.0	3.3	3.2	1.4	4.0	8.0	Q3
TL431CDBVR	SOT-23	DBV	5	3000	180.0	8.4	3.23	3.17	1.37	4.0	8.0	Q3
TL431CDBVT	SOT-23	DBV	5	250	178.0	9.0	3.23	3.17	1.37	4.0	8.0	Q3
TL431CDBVT	SOT-23	DBV	5	250	180.0	8.4	3.23	3.17	1.37	4.0	8.0	Q3
TL431CDBVT	SOT-23	DBV	5	250	178.0	9.0	3.3	3.2	1.4	4.0	8.0	Q3
TL431CDBVTG4	SOT-23	DBV	5	250	178.0	9.0	3.23	3.17	1.37	4.0	8.0	Q3
TL431CDBZR	SOT-23	DBZ	3	3000	178.0	9.0	3.15	2.77	1.22	4.0	8.0	Q3
TL431CDBZR	SOT-23	DBZ	3	3000	178.0	9.2	3.15	2.77	1.22	4.0	8.0	Q3
TL431CDBZRG4	SOT-23	DBZ	3	3000	178.0	9.2	3.15	2.77	1.22	4.0	8.0	Q3
TL431CDBZT	SOT-23	DBZ	3	250	178.0	9.0	3.15	2.77	1.22	4.0	8.0	Q3
TL431CDBZTG4	SOT-23	DBZ	3	250	180.0	8.4	3.15	2.77	1.22	4.0	8.0	Q3
TL431CDR	SOIC	D	8	2500	330.0	12.4	6.4	5.2	2.1	8.0	12.0	Q1
TL431CDR	SOIC	D	8	2500	330.0	12.8	6.4	5.2	2.1	8.0	12.0	Q1
TL431CDRG4	SOIC	D	8	2500	330.0	12.4	6.4	5.2	2.1	8.0	12.0	Q1
TL431CPK	SOT-89	PK	3	1000	180.0	12.4	4.91	4.52	1.9	8.0	12.0	Q3
TL431CPKE6	SOT-89	PK	3	1000	180.0	13.0	4.91	4.52	1.9	8.0	12.0	Q3
TL431CPSR	SO	PS	8	2000	330.0	16.4	8.35	6.6	2.4	12.0	16.0	Q1
TL431CPWR	TSSOP	PW	8	2000	330.0	12.4	7.0	3.6	1.6	8.0	12.0	Q1
TL431IDBVR	SOT-23	DBV	5	3000	180.0	8.4	3.23	3.17	1.37	4.0	8.0	Q3
TL431IDBVR	SOT-23	DBV	5	3000	178.0	9.0	3.23	3.17	1.37	4.0	8.0	Q3
TL431IDBVR	SOT-23	DBV	5	3000	178.0	9.0	3.3	3.2	1.4	4.0	8.0	Q3
TL431IDBVRG4	SOT-23	DBV	5	3000	178.0	9.0	3.23	3.17	1.37	4.0	8.0	Q3
TL431IDBVT	SOT-23	DBV	5	250	178.0	9.0	3.23	3.17	1.37	4.0	8.0	Q3
TL431IDBVT	SOT-23	DBV	5	250	178.0	9.0	3.3	3.2	1.4	4.0	8.0	Q3
TL431IDBZR	SOT-23	DBZ	3	3000	178.0	9.0	3.15	2.77	1.22	4.0	8.0	Q3
TL431IDBZR	SOT-23	DBZ	3	3000	180.0	8.4	3.15	2.77	1.22	4.0	8.0	Q3
TL431IDBZRG4	SOT-23	DBZ	3	3000	180.0	8.4	3.15	2.77	1.22	4.0	8.0	Q3
TL431IDBZT	SOT-23	DBZ	3	250	180.0	8.4	3.15	2.77	1.22	4.0	8.0	Q3
TL431IDBZT	SOT-23	DBZ	3	250	178.0	9.0	3.15	2.77	1.22	4.0	8.0	Q3
TL431IDBZTG4	SOT-23	DBZ	3	250	180.0	8.4	3.15	2.77	1.22	4.0	8.0	Q3
TL431IDR	SOIC	D	8	2500	330.0	12.8	6.4	5.2	2.1	8.0	12.0	Q1
TL431IDR	SOIC	D	8	2500	330.0	12.4	6.4	5.2	2.1	8.0	12.0	Q1
TL431IDRG4	SOIC	D	8	2500	330.0	12.4	6.4	5.2	2.1	8.0	12.0	Q1
TL431IPK	SOT-89	PK	3	1000	180.0	12.4	4.91	4.52	1.9	8.0	12.0	Q3
TL431QDBVR	SOT-23	DBV	5	3000	178.0	9.0	3.23	3.17	1.37	4.0	8.0	Q3
TL431QDBVR	SOT-23	DBV	5	3000	178.0	9.0	3.3	3.2	1.4	4.0	8.0	Q3
TL431QDBVRG4	SOT-23	DBV	5	3000	178.0	9.0	3.23	3.17	1.37	4.0	8.0	Q3
TL431QDBVT	SOT-23	DBV	5	250	178.0	9.0	3.3	3.2	1.4	4.0	8.0	Q3
TL431QDBVT	SOT-23	DBV	5	250	178.0	9.0	3.23	3.17	1.37	4.0	8.0	Q3

Device	Package Type	Package Drawing	Pins	SPQ	Reel Diameter (mm)	Reel Width W1 (mm)	A0 (mm)	B0 (mm)	K0 (mm)	P1 (mm)	W (mm)	Pin1 Quadrant
TL431QDBZR	SOT-23	DBZ	3	3000	178.0	9.0	3.15	2.77	1.22	4.0	8.0	Q3
TL431QDBZR	SOT-23	DBZ	3	3000	180.0	8.4	3.15	2.77	1.22	4.0	8.0	Q3
TL431QDBZRG4	SOT-23	DBZ	3	3000	180.0	8.4	3.15	2.77	1.22	4.0	8.0	Q3
TL431QDBZT	SOT-23	DBZ	3	250	178.0	9.0	3.15	2.77	1.22	4.0	8.0	Q3
TL431QDBZT	SOT-23	DBZ	3	250	180.0	8.4	3.15	2.77	1.22	4.0	8.0	Q3
TL431QDBZTG4	SOT-23	DBZ	3	250	180.0	8.4	3.15	2.77	1.22	4.0	8.0	Q3
TL431QDCKR	SC70	DCK	6	3000	179.0	8.4	2.2	2.5	1.2	4.0	8.0	Q3
TL431QDCKT	SC70	DCK	6	250	179.0	8.4	2.2	2.5	1.2	4.0	8.0	Q3
TL431QDR	SOIC	D	8	2500	330.0	12.4	6.4	5.2	2.1	8.0	12.0	Q1
TL432ACDBVR	SOT-23	DBV	5	3000	178.0	9.0	3.23	3.17	1.37	4.0	8.0	Q3
TL432ACDBVR	SOT-23	DBV	5	3000	178.0	9.0	3.3	3.2	1.4	4.0	8.0	Q3
TL432ACDBZR	SOT-23	DBZ	3	3000	180.0	8.4	3.15	2.77	1.22	4.0	8.0	Q3
TL432ACDBZR	SOT-23	DBZ	3	3000	178.0	9.0	3.15	2.77	1.22	4.0	8.0	Q3
TL432ACDBZRG4	SOT-23	DBZ	3	3000	180.0	8.4	3.15	2.77	1.22	4.0	8.0	Q3
TL432ACDBZT	SOT-23	DBZ	3	250	180.0	8.4	3.15	2.77	1.22	4.0	8.0	Q3
TL432ACDBZT	SOT-23	DBZ	3	250	178.0	9.0	3.15	2.77	1.22	4.0	8.0	Q3
TL432ACDBZTG4	SOT-23	DBZ	3	250	180.0	8.4	3.15	2.77	1.22	4.0	8.0	Q3
TL432AIDBVR	SOT-23	DBV	5	3000	178.0	9.0	3.3	3.2	1.4	4.0	8.0	Q3
TL432AIDBVR	SOT-23	DBV	5	3000	178.0	9.0	3.23	3.17	1.37	4.0	8.0	Q3
TL432AIDBZR	SOT-23	DBZ	3	3000	178.0	9.2	3.15	2.77	1.22	4.0	8.0	Q3
TL432AIDBZR	SOT-23	DBZ	3	3000	178.0	9.0	3.15	2.77	1.22	4.0	8.0	Q3
TL432AIDBZRG4	SOT-23	DBZ	3	3000	178.0	9.2	3.15	2.77	1.22	4.0	8.0	Q3
TL432AIDBZT	SOT-23	DBZ	3	250	178.0	9.0	3.15	2.77	1.22	4.0	8.0	Q3
TL432AIDBZT	SOT-23	DBZ	3	250	178.0	9.2	3.15	2.77	1.22	4.0	8.0	Q3
TL432AIDBZTG4	SOT-23	DBZ	3	250	178.0	9.2	3.15	2.77	1.22	4.0	8.0	Q3
TL432AIPK	SOT-89	PK	3	1000	180.0	12.4	4.91	4.52	1.9	8.0	12.0	Q3
TL432AQDBVR	SOT-23	DBV	5	3000	179.0	8.4	3.2	3.2	1.4	4.0	8.0	Q3
TL432AQDBVR	SOT-23	DBV	5	3000	178.0	9.0	3.3	3.2	1.4	4.0	8.0	Q3
TL432AQDBVT	SOT-23	DBV	5	250	178.0	9.0	3.3	3.2	1.4	4.0	8.0	Q3
TL432AQDBVT	SOT-23	DBV	5	250	179.0	8.4	3.2	3.2	1.4	4.0	8.0	Q3
TL432AQDBZR	SOT-23	DBZ	3	3000	178.0	9.0	3.15	2.77	1.22	4.0	8.0	Q3
TL432AQDBZR	SOT-23	DBZ	3	3000	180.0	8.4	3.15	2.77	1.22	4.0	8.0	Q3
TL432AQDBZRG4	SOT-23	DBZ	3	3000	180.0	8.4	3.15	2.77	1.22	4.0	8.0	Q3
TL432AQDBZT	SOT-23	DBZ	3	250	178.0	9.0	3.15	2.77	1.22	4.0	8.0	Q3
TL432AQDBZT	SOT-23	DBZ	3	250	180.0	8.4	3.15	2.77	1.22	4.0	8.0	Q3
TL432AQDBZTG4	SOT-23	DBZ	3	250	180.0	8.4	3.15	2.77	1.22	4.0	8.0	Q3
TL432AQPK	SOT-89	PK	3	1000	180.0	12.4	4.91	4.52	1.9	8.0	12.0	Q3
TL432BCDBVR	SOT-23	DBV	5	3000	178.0	9.0	3.3	3.2	1.4	4.0	8.0	Q3
TL432BCDBVR	SOT-23	DBV	5	3000	180.0	8.4	3.2	3.2	1.4	4.0	8.0	Q3
TL432BCDBZR	SOT-23	DBZ	3	3000	178.0	9.0	3.15	2.77	1.22	4.0	8.0	Q3
TL432BCDBZR	SOT-23	DBZ	3	3000	180.0	8.4	3.15	2.77	1.22	4.0	8.0	Q3

Device	Package Type	Package Drawing	Pins	SPQ	Reel Diameter (mm)	Reel Width W1 (mm)	A0 (mm)	B0 (mm)	K0 (mm)	P1 (mm)	W (mm)	Pin1 Quadrant
TL432BCDBZRG4	SOT-23	DBZ	3	3000	180.0	8.4	3.15	2.77	1.22	4.0	8.0	Q3
TL432BCDBZT	SOT-23	DBZ	3	250	178.0	9.0	3.15	2.77	1.22	4.0	8.0	Q3
TL432BCDBZTG4	SOT-23	DBZ	3	250	180.0	8.4	3.15	2.77	1.22	4.0	8.0	Q3
TL432BCPK	SOT-89	PK	3	1000	180.0	12.4	4.91	4.52	1.9	8.0	12.0	Q3
TL432BIDBZR	SOT-23	DBZ	3	3000	178.0	9.0	3.15	2.77	1.22	4.0	8.0	Q3
TL432BIDBZR	SOT-23	DBZ	3	3000	178.0	9.2	3.15	2.77	1.22	4.0	8.0	Q3
TL432BIDBZRG4	SOT-23	DBZ	3	3000	178.0	9.2	3.15	2.77	1.22	4.0	8.0	Q3
TL432BIDBZT	SOT-23	DBZ	3	250	178.0	9.2	3.15	2.77	1.22	4.0	8.0	Q3
TL432BIDBZT	SOT-23	DBZ	3	250	178.0	9.0	3.15	2.77	1.22	4.0	8.0	Q3
TL432BIDBZTG4	SOT-23	DBZ	3	250	178.0	9.2	3.15	2.77	1.22	4.0	8.0	Q3
TL432BIPK	SOT-89	PK	3	1000	180.0	12.4	4.91	4.52	1.9	8.0	12.0	Q3
TL432BQDBZR	SOT-23	DBZ	3	3000	179.0	8.4	3.15	2.95	1.22	4.0	8.0	Q3
TL432BQDBZR	SOT-23	DBZ	3	3000	178.0	9.2	3.15	2.77	1.22	4.0	8.0	Q3
TL432BQDBZR	SOT-23	DBZ	3	3000	180.0	8.4	3.15	2.77	1.22	4.0	8.0	Q3
TL432BQPK	SOT-89	PK	3	1000	180.0	12.4	4.91	4.52	1.9	8.0	12.0	Q3
TL432CDBVR	SOT-23	DBV	5	3000	178.0	9.0	3.23	3.17	1.37	4.0	8.0	Q3
TL432CDBVR	SOT-23	DBV	5	3000	178.0	9.0	3.3	3.2	1.4	4.0	8.0	Q3
TL432CDBZR	SOT-23	DBZ	3	3000	180.0	8.4	3.15	2.77	1.22	4.0	8.0	Q3
TL432CDBZR	SOT-23	DBZ	3	3000	178.0	9.0	3.15	2.77	1.22	4.0	8.0	Q3
TL432CDBZRG4	SOT-23	DBZ	3	3000	180.0	8.4	3.15	2.77	1.22	4.0	8.0	Q3
TL432CPK	SOT-89	PK	3	1000	180.0	12.4	4.91	4.52	1.9	8.0	12.0	Q3
TL432IDBVR	SOT-23	DBV	5	3000	178.0	9.0	3.3	3.2	1.4	4.0	8.0	Q3
TL432IDBVR	SOT-23	DBV	5	3000	178.0	9.0	3.23	3.17	1.37	4.0	8.0	Q3
TL432IDBZR	SOT-23	DBZ	3	3000	178.0	9.0	3.15	2.77	1.22	4.0	8.0	Q3
TL432IDBZR	SOT-23	DBZ	3	3000	180.0	8.4	3.15	2.77	1.22	4.0	8.0	Q3
TL432IDBZRG4	SOT-23	DBZ	3	3000	180.0	8.4	3.15	2.77	1.22	4.0	8.0	Q3
TL432IDBZT	SOT-23	DBZ	3	250	180.0	8.4	3.15	2.77	1.22	4.0	8.0	Q3
TL432IDBZT	SOT-23	DBZ	3	250	178.0	9.0	3.15	2.77	1.22	4.0	8.0	Q3
TL432IDBZTG4	SOT-23	DBZ	3	250	180.0	8.4	3.15	2.77	1.22	4.0	8.0	Q3
TL432IPK	SOT-89	PK	3	1000	180.0	12.4	4.91	4.52	1.9	8.0	12.0	Q3
TL432QDBZR	SOT-23	DBZ	3	3000	180.0	8.4	3.15	2.77	1.22	4.0	8.0	Q3
TL432QDBZR	SOT-23	DBZ	3	3000	178.0	9.0	3.15	2.77	1.22	4.0	8.0	Q3
TL432QDBZRG4	SOT-23	DBZ	3	3000	180.0	8.4	3.15	2.77	1.22	4.0	8.0	Q3
TL432QPK	SOT-89	PK	3	1000	180.0	12.4	4.91	4.52	1.9	8.0	12.0	Q3

TAPE AND REEL BOX DIMENSIONS

*All dimensions are nominal

Device	Package Type	Package Drawing	Pins	SPQ	Length (mm)	Width (mm)	Height (mm)
TL431ACDBVR	SOT-23	DBV	5	3000	180.0	180.0	18.0
TL431ACDBVR	SOT-23	DBV	5	3000	180.0	180.0	18.0
TL431ACDBVR	SOT-23	DBV	5	3000	183.0	183.0	20.0
TL431ACDBVRG4	SOT-23	DBV	5	3000	180.0	180.0	18.0
TL431ACDBVT	SOT-23	DBV	5	250	180.0	180.0	18.0
TL431ACDBVT	SOT-23	DBV	5	250	180.0	180.0	18.0
TL431ACDBZR	SOT-23	DBZ	3	3000	180.0	180.0	18.0
TL431ACDBZR	SOT-23	DBZ	3	3000	180.0	180.0	18.0
TL431ACDBZRG4	SOT-23	DBZ	3	3000	180.0	180.0	18.0
TL431ACDBZT	SOT-23	DBZ	3	250	180.0	180.0	18.0
TL431ACDBZT	SOT-23	DBZ	3	250	180.0	180.0	18.0
TL431ACDBZTG4	SOT-23	DBZ	3	250	180.0	180.0	18.0
TL431ACDCKR	SC70	DCK	6	3000	183.0	183.0	20.0
TL431ACDR	SOIC	D	8	2500	340.5	336.1	25.0
TL431ACDR	SOIC	D	8	2500	364.0	364.0	27.0
TL431ACDRG4	SOIC	D	8	2500	340.5	336.1	25.0
TL431ACPK	SOT-89	PK	3	1000	340.0	340.0	38.0
TL431ACPSR	SO	PS	8	2000	356.0	356.0	35.0

Device	Package Type	Package Drawing	Pins	SPQ	Length (mm)	Width (mm)	Height (mm)
TL431ACPWR	TSSOP	PW	8	2000	356.0	356.0	35.0
TL431AIDBVR	SOT-23	DBV	5	3000	180.0	180.0	18.0
TL431AIDBVR	SOT-23	DBV	5	3000	183.0	183.0	20.0
TL431AIDBVR	SOT-23	DBV	5	3000	180.0	180.0	18.0
TL431AIDBVRG4	SOT-23	DBV	5	3000	180.0	180.0	18.0
TL431AIDBVT	SOT-23	DBV	5	250	180.0	180.0	18.0
TL431AIDBVT	SOT-23	DBV	5	250	180.0	180.0	18.0
TL431AIDBVTG4	SOT-23	DBV	5	250	180.0	180.0	18.0
TL431AIDBZR	SOT-23	DBZ	3	3000	180.0	180.0	18.0
TL431AIDBZR	SOT-23	DBZ	3	3000	180.0	180.0	18.0
TL431AIDBZRG4	SOT-23	DBZ	3	3000	180.0	180.0	18.0
TL431AIDBZT	SOT-23	DBZ	3	250	180.0	180.0	18.0
TL431AIDBZT	SOT-23	DBZ	3	250	180.0	180.0	18.0
TL431AIDBZTG4	SOT-23	DBZ	3	250	180.0	180.0	18.0
TL431AIDCKR	SC70	DCK	6	3000	200.0	183.0	25.0
TL431AIDCKT	SC70	DCK	6	250	200.0	183.0	25.0
TL431AIDR	SOIC	D	8	2500	340.5	336.1	25.0
TL431AIDR	SOIC	D	8	2500	364.0	364.0	27.0
TL431AIDRG4	SOIC	D	8	2500	340.5	336.1	25.0
TL431AIPK	SOT-89	PK	3	1000	340.0	340.0	38.0
TL431AQDBVR	SOT-23	DBV	5	3000	180.0	180.0	18.0
TL431AQDBVR	SOT-23	DBV	5	3000	180.0	180.0	18.0
TL431AQDBVT	SOT-23	DBV	5	250	180.0	180.0	18.0
TL431AQDBVT	SOT-23	DBV	5	250	180.0	180.0	18.0
TL431AQDBZR	SOT-23	DBZ	3	3000	180.0	180.0	18.0
TL431AQDBZR	SOT-23	DBZ	3	3000	183.0	183.0	20.0
TL431AQDBZRG4	SOT-23	DBZ	3	3000	183.0	183.0	20.0
TL431AQDBZT	SOT-23	DBZ	3	250	183.0	183.0	20.0
TL431AQDBZT	SOT-23	DBZ	3	250	180.0	180.0	18.0
TL431AQDBZTG4	SOT-23	DBZ	3	250	183.0	183.0	20.0
TL431AQDCKR	SC70	DCK	6	3000	200.0	183.0	25.0
TL431AQDCKT	SC70	DCK	6	250	200.0	183.0	25.0
TL431AQPK	SOT-89	PK	3	1000	340.0	340.0	38.0
TL431BCDBVR	SOT-23	DBV	5	3000	180.0	180.0	18.0
TL431BCDBVR	SOT-23	DBV	5	3000	180.0	180.0	18.0
TL431BCDBVT	SOT-23	DBV	5	250	180.0	180.0	18.0
TL431BCDBVT	SOT-23	DBV	5	250	180.0	180.0	18.0
TL431BCDBVTG4	SOT-23	DBV	5	250	180.0	180.0	18.0
TL431BCDBZR	SOT-23	DBZ	3	3000	180.0	180.0	18.0
TL431BCDBZR	SOT-23	DBZ	3	3000	180.0	180.0	18.0
TL431BCDBZRG4	SOT-23	DBZ	3	3000	180.0	180.0	18.0
TL431BCDBZT	SOT-23	DBZ	3	250	180.0	180.0	18.0
TL431BCDBZT	SOT-23	DBZ	3	250	180.0	180.0	18.0

Device	Package Type	Package Drawing	Pins	SPQ	Length (mm)	Width (mm)	Height (mm)
TL431BCDBZTG4	SOT-23	DBZ	3	250	180.0	180.0	18.0
TL431BCDCKR	SC70	DCK	6	3000	200.0	183.0	25.0
TL431BCDCKT	SC70	DCK	6	250	200.0	183.0	25.0
TL431BCDR	SOIC	D	8	2500	340.5	336.1	25.0
TL431BCPK	SOT-89	PK	3	1000	340.0	340.0	38.0
TL431BCPSR	SO	PS	8	2000	356.0	356.0	35.0
TL431BCPWR	TSSOP	PW	8	2000	356.0	356.0	35.0
TL431BIDBVR	SOT-23	DBV	5	3000	180.0	180.0	18.0
TL431BIDBVR	SOT-23	DBV	5	3000	180.0	180.0	18.0
TL431BIDBVT	SOT-23	DBV	5	250	180.0	180.0	18.0
TL431BIDBVT	SOT-23	DBV	5	250	180.0	180.0	18.0
TL431BIDBVTG4	SOT-23	DBV	5	250	180.0	180.0	18.0
TL431BIDBZR	SOT-23	DBZ	3	3000	180.0	180.0	18.0
TL431BIDBZR	SOT-23	DBZ	3	3000	180.0	180.0	18.0
TL431BIDBZRG4	SOT-23	DBZ	3	3000	180.0	180.0	18.0
TL431BIDBZT	SOT-23	DBZ	3	250	180.0	180.0	18.0
TL431BIDBZT	SOT-23	DBZ	3	250	180.0	180.0	18.0
TL431BIDBZTG4	SOT-23	DBZ	3	250	180.0	180.0	18.0
TL431BIDCKR	SC70	DCK	6	3000	200.0	183.0	25.0
TL431BIDCKT	SC70	DCK	6	250	203.0	203.0	35.0
TL431BIDR	SOIC	D	8	2500	340.5	336.1	25.0
TL431BIDR	SOIC	D	8	2500	364.0	364.0	27.0
TL431BIDRG4	SOIC	D	8	2500	340.5	336.1	25.0
TL431BIPK	SOT-89	PK	3	1000	340.0	340.0	38.0
TL431BQDBVR	SOT-23	DBV	5	3000	180.0	180.0	18.0
TL431BQDBVR	SOT-23	DBV	5	3000	200.0	183.0	25.0
TL431BQDBVT	SOT-23	DBV	5	250	200.0	183.0	25.0
TL431BQDBVT	SOT-23	DBV	5	250	180.0	180.0	18.0
TL431BQDBZR	SOT-23	DBZ	3	3000	183.0	183.0	20.0
TL431BQDBZR	SOT-23	DBZ	3	3000	180.0	180.0	18.0
TL431BQDBZR	SOT-23	DBZ	3	3000	180.0	180.0	18.0
TL431BQDBZRG4	SOT-23	DBZ	3	3000	183.0	183.0	20.0
TL431BQDBZT	SOT-23	DBZ	3	250	183.0	183.0	20.0
TL431BQDBZT	SOT-23	DBZ	3	250	180.0	180.0	18.0
TL431BQDBZTG4	SOT-23	DBZ	3	250	183.0	183.0	20.0
TL431BQDCKR	SC70	DCK	6	3000	200.0	183.0	25.0
TL431BQDCKT	SC70	DCK	6	250	203.0	203.0	35.0
TL431BQDR	SOIC	D	8	2500	340.5	336.1	25.0
TL431CDBVR	SOT-23	DBV	5	3000	180.0	180.0	18.0
TL431CDBVR	SOT-23	DBV	5	3000	180.0	180.0	18.0
TL431CDBVR	SOT-23	DBV	5	3000	183.0	183.0	20.0
TL431CDBVT	SOT-23	DBV	5	250	180.0	180.0	18.0
TL431CDBVT	SOT-23	DBV	5	250	183.0	183.0	20.0

Device	Package Type	Package Drawing	Pins	SPQ	Length (mm)	Width (mm)	Height (mm)
TL431CDBVT	SOT-23	DBV	5	250	180.0	180.0	18.0
TL431CDBVTG4	SOT-23	DBV	5	250	180.0	180.0	18.0
TL431CDBZR	SOT-23	DBZ	3	3000	180.0	180.0	18.0
TL431CDBZR	SOT-23	DBZ	3	3000	180.0	180.0	18.0
TL431CDBZRG4	SOT-23	DBZ	3	3000	180.0	180.0	18.0
TL431CDBZT	SOT-23	DBZ	3	250	180.0	180.0	18.0
TL431CDBZTG4	SOT-23	DBZ	3	250	183.0	183.0	20.0
TL431CDR	SOIC	D	8	2500	340.5	336.1	25.0
TL431CDR	SOIC	D	8	2500	364.0	364.0	27.0
TL431CDRG4	SOIC	D	8	2500	340.5	336.1	25.0
TL431CPK	SOT-89	PK	3	1000	340.0	340.0	38.0
TL431CPKE6	SOT-89	PK	3	1000	182.0	182.0	20.0
TL431CPSR	SO	PS	8	2000	356.0	356.0	35.0
TL431CPWR	TSSOP	PW	8	2000	356.0	356.0	35.0
TL431IDBVR	SOT-23	DBV	5	3000	183.0	183.0	20.0
TL431IDBVR	SOT-23	DBV	5	3000	180.0	180.0	18.0
TL431IDBVR	SOT-23	DBV	5	3000	180.0	180.0	18.0
TL431IDBVRG4	SOT-23	DBV	5	3000	180.0	180.0	18.0
TL431IDBVT	SOT-23	DBV	5	250	180.0	180.0	18.0
TL431IDBVT	SOT-23	DBV	5	250	180.0	180.0	18.0
TL431IDBZR	SOT-23	DBZ	3	3000	180.0	180.0	18.0
TL431IDBZR	SOT-23	DBZ	3	3000	183.0	183.0	20.0
TL431IDBZRG4	SOT-23	DBZ	3	3000	183.0	183.0	20.0
TL431IDBZT	SOT-23	DBZ	3	250	183.0	183.0	20.0
TL431IDBZT	SOT-23	DBZ	3	250	180.0	180.0	18.0
TL431IDBZTG4	SOT-23	DBZ	3	250	183.0	183.0	20.0
TL431IDR	SOIC	D	8	2500	364.0	364.0	27.0
TL431IDR	SOIC	D	8	2500	340.5	336.1	25.0
TL431IDRG4	SOIC	D	8	2500	340.5	336.1	25.0
TL431IPK	SOT-89	PK	3	1000	340.0	340.0	38.0
TL431QDBVR	SOT-23	DBV	5	3000	180.0	180.0	18.0
TL431QDBVR	SOT-23	DBV	5	3000	180.0	180.0	18.0
TL431QDBVRG4	SOT-23	DBV	5	3000	180.0	180.0	18.0
TL431QDBVT	SOT-23	DBV	5	250	180.0	180.0	18.0
TL431QDBVT	SOT-23	DBV	5	250	180.0	180.0	18.0
TL431QDBZR	SOT-23	DBZ	3	3000	180.0	180.0	18.0
TL431QDBZR	SOT-23	DBZ	3	3000	183.0	183.0	20.0
TL431QDBZRG4	SOT-23	DBZ	3	3000	183.0	183.0	20.0
TL431QDBZT	SOT-23	DBZ	3	250	180.0	180.0	18.0
TL431QDBZT	SOT-23	DBZ	3	250	183.0	183.0	20.0
TL431QDBZTG4	SOT-23	DBZ	3	250	183.0	183.0	20.0
TL431QDCKR	SC70	DCK	6	3000	203.0	203.0	35.0
TL431QDCKT	SC70	DCK	6	250	203.0	203.0	35.0

Device	Package Type	Package Drawing	Pins	SPQ	Length (mm)	Width (mm)	Height (mm)
TL431QDR	SOIC	D	8	2500	340.5	336.1	25.0
TL432ACDBVR	SOT-23	DBV	5	3000	180.0	180.0	18.0
TL432ACDBVR	SOT-23	DBV	5	3000	180.0	180.0	18.0
TL432ACDBZR	SOT-23	DBZ	3	3000	183.0	183.0	20.0
TL432ACDBZR	SOT-23	DBZ	3	3000	180.0	180.0	18.0
TL432ACDBZRG4	SOT-23	DBZ	3	3000	183.0	183.0	20.0
TL432ACDBZT	SOT-23	DBZ	3	250	183.0	183.0	20.0
TL432ACDBZT	SOT-23	DBZ	3	250	180.0	180.0	18.0
TL432ACDBZTG4	SOT-23	DBZ	3	250	183.0	183.0	20.0
TL432AIDBVR	SOT-23	DBV	5	3000	180.0	180.0	18.0
TL432AIDBVR	SOT-23	DBV	5	3000	180.0	180.0	18.0
TL432AIDBZR	SOT-23	DBZ	3	3000	180.0	180.0	18.0
TL432AIDBZR	SOT-23	DBZ	3	3000	180.0	180.0	18.0
TL432AIDBZRG4	SOT-23	DBZ	3	3000	180.0	180.0	18.0
TL432AIDBZT	SOT-23	DBZ	3	250	180.0	180.0	18.0
TL432AIDBZT	SOT-23	DBZ	3	250	180.0	180.0	18.0
TL432AIDBZTG4	SOT-23	DBZ	3	250	180.0	180.0	18.0
TL432AIPK	SOT-89	PK	3	1000	340.0	340.0	38.0
TL432AQDBVR	SOT-23	DBV	5	3000	203.0	203.0	35.0
TL432AQDBVR	SOT-23	DBV	5	3000	180.0	180.0	18.0
TL432AQDBVT	SOT-23	DBV	5	250	180.0	180.0	18.0
TL432AQDBVT	SOT-23	DBV	5	250	203.0	203.0	35.0
TL432AQDBZR	SOT-23	DBZ	3	3000	180.0	180.0	18.0
TL432AQDBZR	SOT-23	DBZ	3	3000	183.0	183.0	20.0
TL432AQDBZRG4	SOT-23	DBZ	3	3000	183.0	183.0	20.0
TL432AQDBZT	SOT-23	DBZ	3	250	180.0	180.0	18.0
TL432AQDBZT	SOT-23	DBZ	3	250	183.0	183.0	20.0
TL432AQDBZTG4	SOT-23	DBZ	3	250	183.0	183.0	20.0
TL432AQPCK	SOT-89	PK	3	1000	340.0	340.0	38.0
TL432BCDBVR	SOT-23	DBV	5	3000	180.0	180.0	18.0
TL432BCDBVR	SOT-23	DBV	5	3000	200.0	183.0	25.0
TL432BCDBZR	SOT-23	DBZ	3	3000	180.0	180.0	18.0
TL432BCDBZR	SOT-23	DBZ	3	3000	183.0	183.0	20.0
TL432BCDBZRG4	SOT-23	DBZ	3	3000	183.0	183.0	20.0
TL432BCDBZT	SOT-23	DBZ	3	250	180.0	180.0	18.0
TL432BCDBZTG4	SOT-23	DBZ	3	250	183.0	183.0	20.0
TL432BCPK	SOT-89	PK	3	1000	340.0	340.0	38.0
TL432BIDBZR	SOT-23	DBZ	3	3000	180.0	180.0	18.0
TL432BIDBZR	SOT-23	DBZ	3	3000	180.0	180.0	18.0
TL432BIDBZRG4	SOT-23	DBZ	3	3000	180.0	180.0	18.0
TL432BIDBZT	SOT-23	DBZ	3	250	180.0	180.0	18.0
TL432BIDBZT	SOT-23	DBZ	3	250	180.0	180.0	18.0
TL432BIDBZTG4	SOT-23	DBZ	3	250	180.0	180.0	18.0

Device	Package Type	Package Drawing	Pins	SPQ	Length (mm)	Width (mm)	Height (mm)
TL432BIPK	SOT-89	PK	3	1000	340.0	340.0	38.0
TL432BQDBZR	SOT-23	DBZ	3	3000	200.0	183.0	25.0
TL432BQDBZR	SOT-23	DBZ	3	3000	180.0	180.0	18.0
TL432BQDBZR	SOT-23	DBZ	3	3000	183.0	183.0	20.0
TL432BQPK	SOT-89	PK	3	1000	340.0	340.0	38.0
TL432CDBVR	SOT-23	DBV	5	3000	180.0	180.0	18.0
TL432CDBVR	SOT-23	DBV	5	3000	180.0	180.0	18.0
TL432CDBZR	SOT-23	DBZ	3	3000	183.0	183.0	20.0
TL432CDBZR	SOT-23	DBZ	3	3000	180.0	180.0	18.0
TL432CDBZRG4	SOT-23	DBZ	3	3000	183.0	183.0	20.0
TL432CPK	SOT-89	PK	3	1000	340.0	340.0	38.0
TL432IDBVR	SOT-23	DBV	5	3000	180.0	180.0	18.0
TL432IDBVR	SOT-23	DBV	5	3000	180.0	180.0	18.0
TL432IDBZR	SOT-23	DBZ	3	3000	180.0	180.0	18.0
TL432IDBZR	SOT-23	DBZ	3	3000	183.0	183.0	20.0
TL432IDBZRG4	SOT-23	DBZ	3	3000	183.0	183.0	20.0
TL432IDBZT	SOT-23	DBZ	3	250	183.0	183.0	20.0
TL432IDBZT	SOT-23	DBZ	3	250	180.0	180.0	18.0
TL432IDBZTG4	SOT-23	DBZ	3	250	183.0	183.0	20.0
TL432IPK	SOT-89	PK	3	1000	340.0	340.0	38.0
TL432QDBZR	SOT-23	DBZ	3	3000	183.0	183.0	20.0
TL432QDBZR	SOT-23	DBZ	3	3000	180.0	180.0	18.0
TL432QDBZRG4	SOT-23	DBZ	3	3000	183.0	183.0	20.0
TL432QPK	SOT-89	PK	3	1000	340.0	340.0	38.0

TUBE

*All dimensions are nominal

Device	Package Name	Package Type	Pins	SPQ	L (mm)	W (mm)	T (µm)	B (mm)
TL431ACD	D	SOIC	8	75	507	8	3940	4.32
TL431ACDG4	D	SOIC	8	75	507	8	3940	4.32
TL431ACP	P	PDIP	8	50	506	13.97	11230	4.32
TL431ACPW	PW	TSSOP	8	150	530	10.2	3600	3.5
TL431AID	D	SOIC	8	75	507	8	3940	4.32
TL431AIDG4	D	SOIC	8	75	507	8	3940	4.32
TL431AIP	P	PDIP	8	50	506	13.97	11230	4.32
TL431AIPE4	P	PDIP	8	50	506	13.97	11230	4.32
TL431BCD	D	SOIC	8	75	507	8	3940	4.32
TL431BCDE4	D	SOIC	8	75	507	8	3940	4.32
TL431BCP	P	PDIP	8	50	506	13.97	11230	4.32
TL431BID	D	SOIC	8	75	507	8	3940	4.32
TL431BIDE4	D	SOIC	8	75	507	8	3940	4.32
TL431BIDG4	D	SOIC	8	75	507	8	3940	4.32
TL431BIP	P	PDIP	8	50	506	13.97	11230	4.32
TL431BQD	D	SOIC	8	75	507	8	3940	4.32
TL431BQDE4	D	SOIC	8	75	507	8	3940	4.32
TL431CD	D	SOIC	8	75	507	8	3940	4.32
TL431CDE4	D	SOIC	8	75	507	8	3940	4.32
TL431CDG4	D	SOIC	8	75	507	8	3940	4.32
TL431CP	P	PDIP	8	50	506	13.97	11230	4.32
TL431CPE4	P	PDIP	8	50	506	13.97	11230	4.32
TL431ID	D	SOIC	8	75	507	8	3940	4.32
TL431IDG4	D	SOIC	8	75	507	8	3940	4.32
TL431IP	P	PDIP	8	50	506	13.97	11230	4.32
TL431IPE4	P	PDIP	8	50	506	13.97	11230	4.32
TL431QD	D	SOIC	8	75	507	8	3940	4.32

GENERIC PACKAGE VIEW

DBZ 3

SOT-23 - 1.12 mm max height

SMALL OUTLINE TRANSISTOR

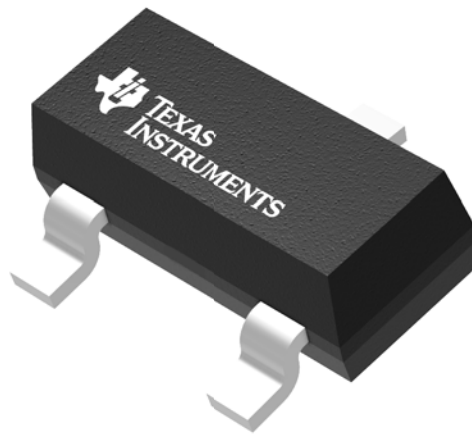

Images above are just a representation of the package family, actual package may vary.
Refer to the product data sheet for package details.

4203227/C

DBZ0003A



PACKAGE OUTLINE

SOT-23 - 1.12 mm max height

SMALL OUTLINE TRANSISTOR

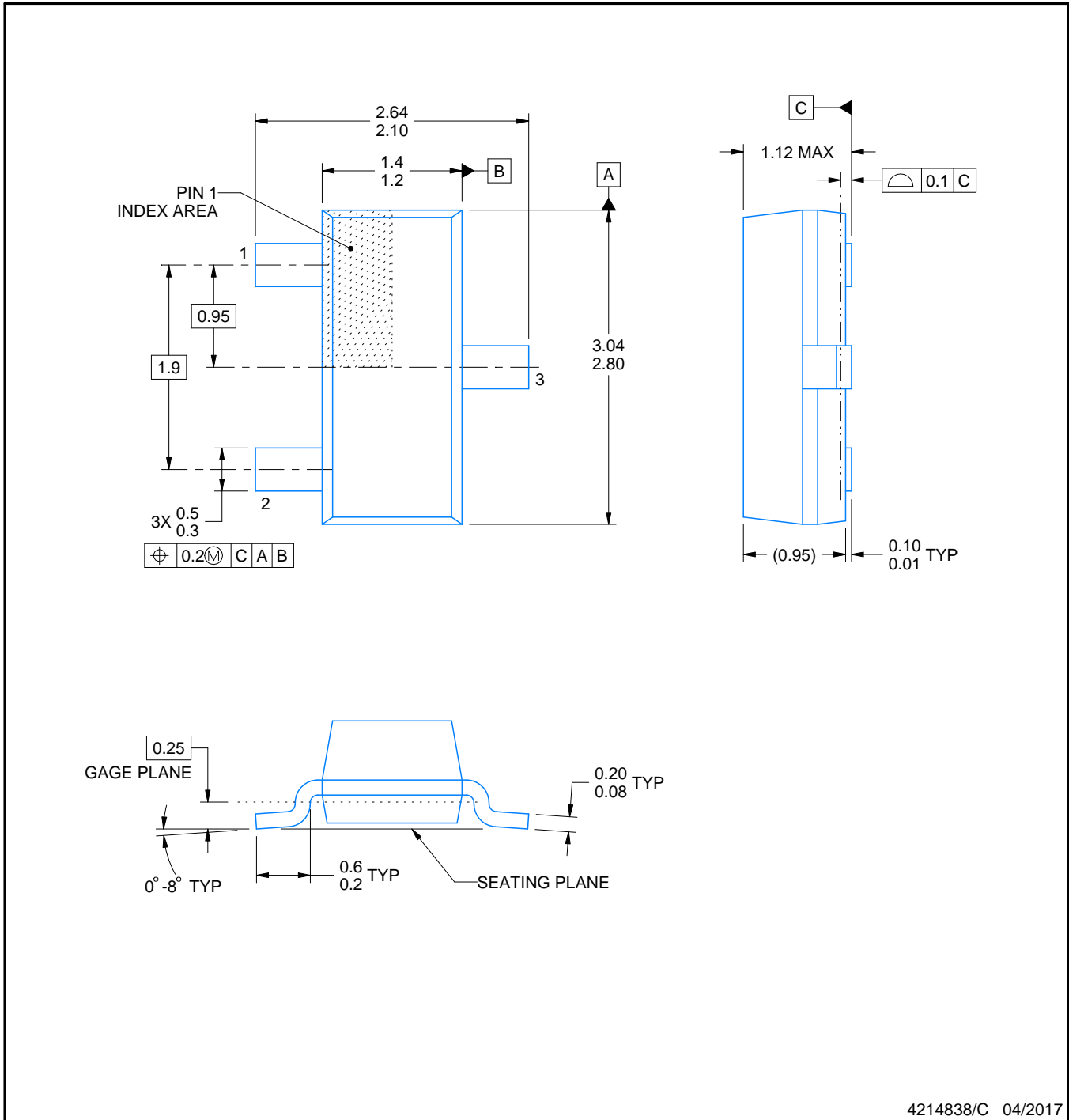

4214838/C 04/2017

NOTES:

1. All linear dimensions are in millimeters. Any dimensions in parenthesis are for reference only. Dimensioning and tolerancing per ASME Y14.5M.
2. This drawing is subject to change without notice.
3. Reference JEDEC registration TO-236, except minimum foot length.

EXAMPLE BOARD LAYOUT

DBZ0003A

SOT-23 - 1.12 mm max height

SMALL OUTLINE TRANSISTOR

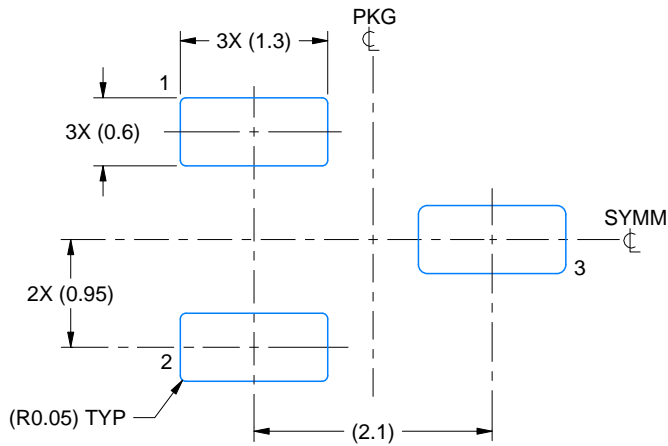

LAND PATTERN EXAMPLE
SCALE:15X

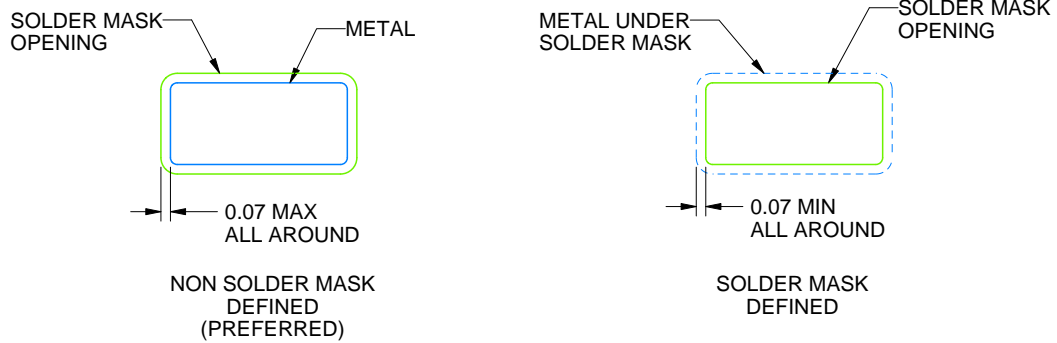

SOLDER MASK DETAILS

4214838/C 04/2017

NOTES: (continued)

4. Publication IPC-7351 may have alternate designs.
5. Solder mask tolerances between and around signal pads can vary based on board fabrication site.

EXAMPLE STENCIL DESIGN

DBZ0003A

SOT-23 - 1.12 mm max height

SMALL OUTLINE TRANSISTOR

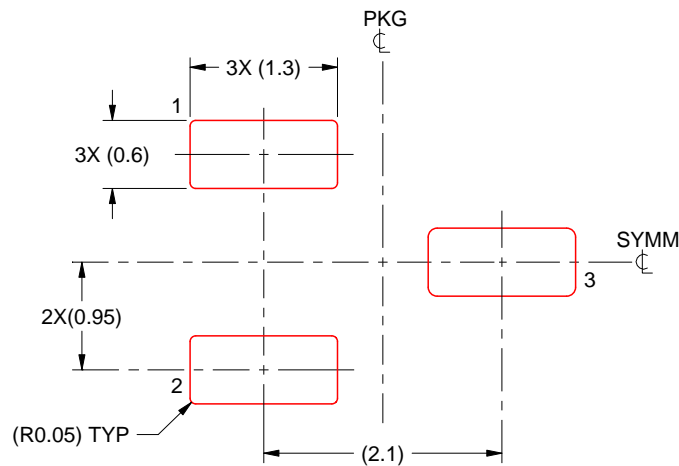

SOLDER PASTE EXAMPLE
BASED ON 0.125 THICK STENCIL
SCALE:15X

4214838/C 04/2017

NOTES: (continued)

6. Laser cutting apertures with trapezoidal walls and rounded corners may offer better paste release. IPC-7525 may have alternate design recommendations.
7. Board assembly site may have different recommendations for stencil design.

DBV0005A



PACKAGE OUTLINE

SOT-23 - 1.45 mm max height

SMALL OUTLINE TRANSISTOR

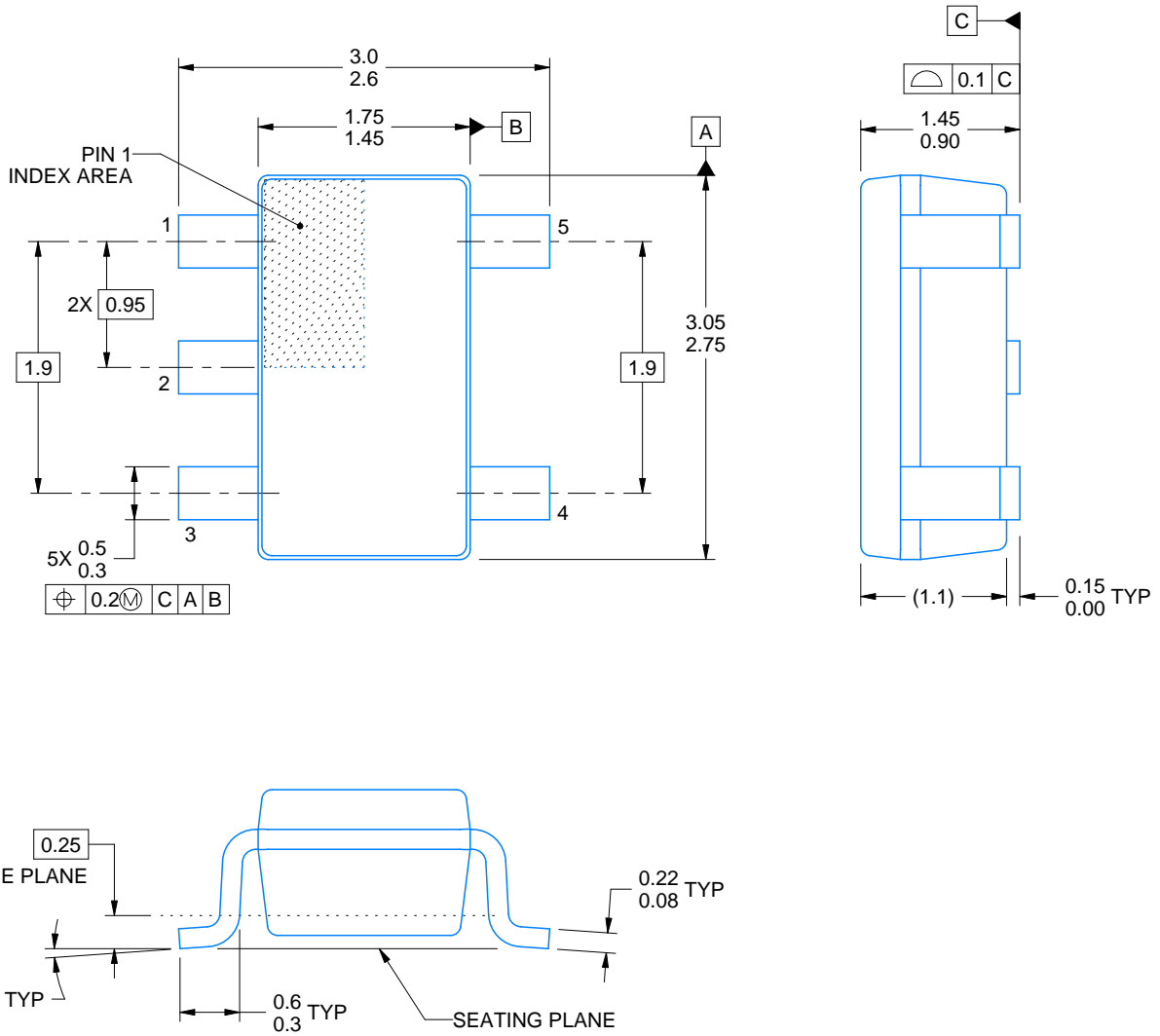

4214839/F 06/2021

NOTES:

1. All linear dimensions are in millimeters. Any dimensions in parenthesis are for reference only. Dimensioning and tolerancing per ASME Y14.5M.
2. This drawing is subject to change without notice.
3. Reference JEDEC MO-178.
4. Body dimensions do not include mold flash, protrusions, or gate burrs. Mold flash, protrusions, or gate burrs shall not exceed 0.25 mm per side.

EXAMPLE BOARD LAYOUT

DBV0005A

SOT-23 - 1.45 mm max height

SMALL OUTLINE TRANSISTOR



LAND PATTERN EXAMPLE
EXPOSED METAL SHOWN
SCALE:15X



SOLDER MASK DETAILS

4214839/F 06/2021

NOTES: (continued)

- 5. Publication IPC-7351 may have alternate designs.
- 6. Solder mask tolerances between and around signal pads can vary based on board fabrication site.

EXAMPLE STENCIL DESIGN

DBV0005A

SOT-23 - 1.45 mm max height

SMALL OUTLINE TRANSISTOR



SOLDER PASTE EXAMPLE
BASED ON 0.125 mm THICK STENCIL
SCALE:15X

4214839/F 06/2021

NOTES: (continued)

7. Laser cutting apertures with trapezoidal walls and rounded corners may offer better paste release. IPC-7525 may have alternate design recommendations.
8. Board assembly site may have different recommendations for stencil design.

PK (R-PSS0-F3)

PLASTIC SINGLE-IN-LINE PACKAGE

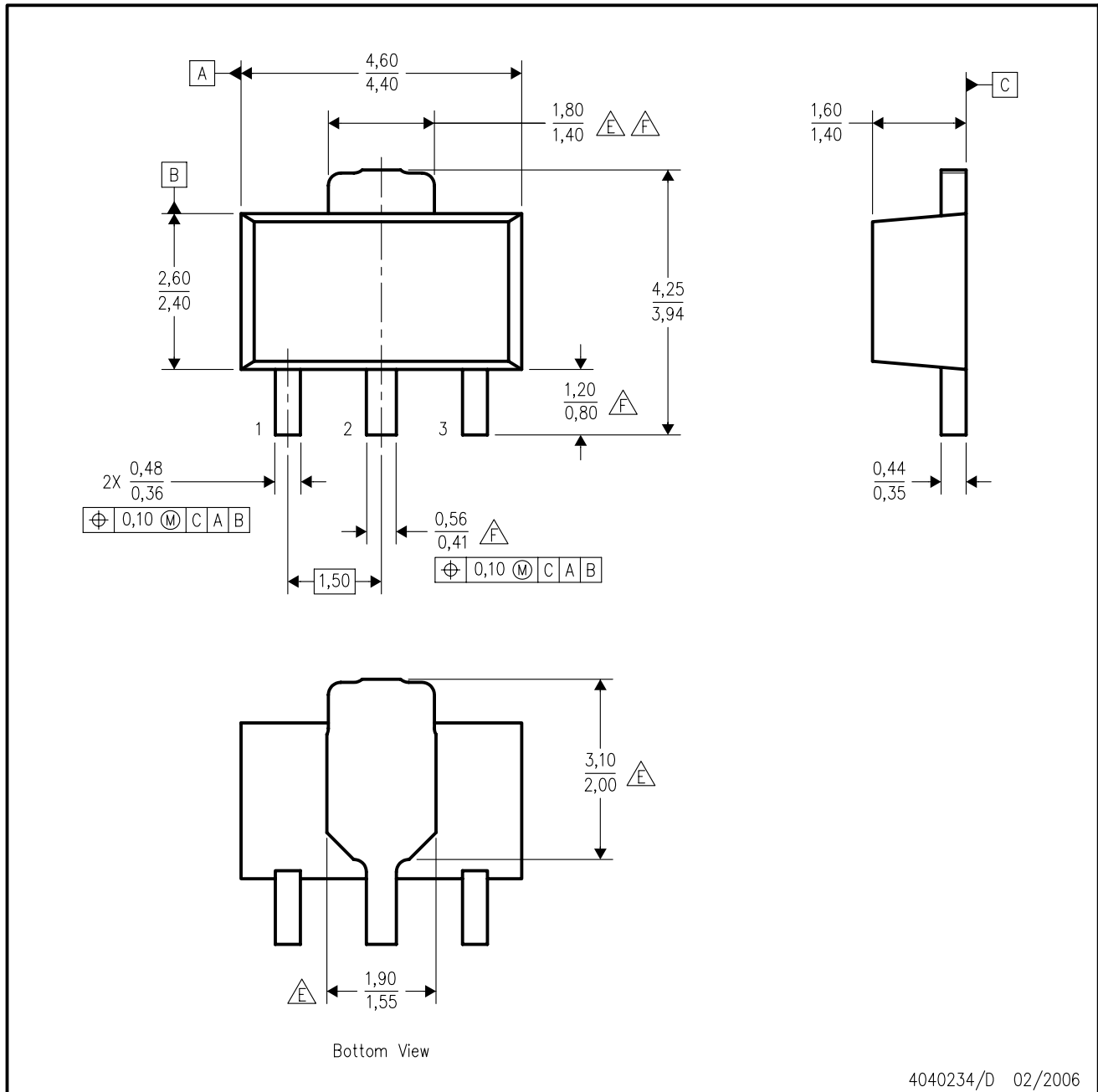

4040234/D 02/2006

- NOTES:
- All linear dimensions are in millimeters. Dimensioning and tolerancing per ASME Y14.5M-1994.
 - This drawing is subject to change without notice.
 - The center lead is in electrical contact with the tab.
 - Body dimensions do not include mold flash or protrusion. Mold flash and protrusion not to exceed 0.15 per side.
- △E Thermal pad contour optional within these dimensions.
 △F Falls within JEDEC TO-243 variation AA, except minimum lead length, pin 2 minimum lead width, minimum tab width.

PK (R-PDSO-G3)

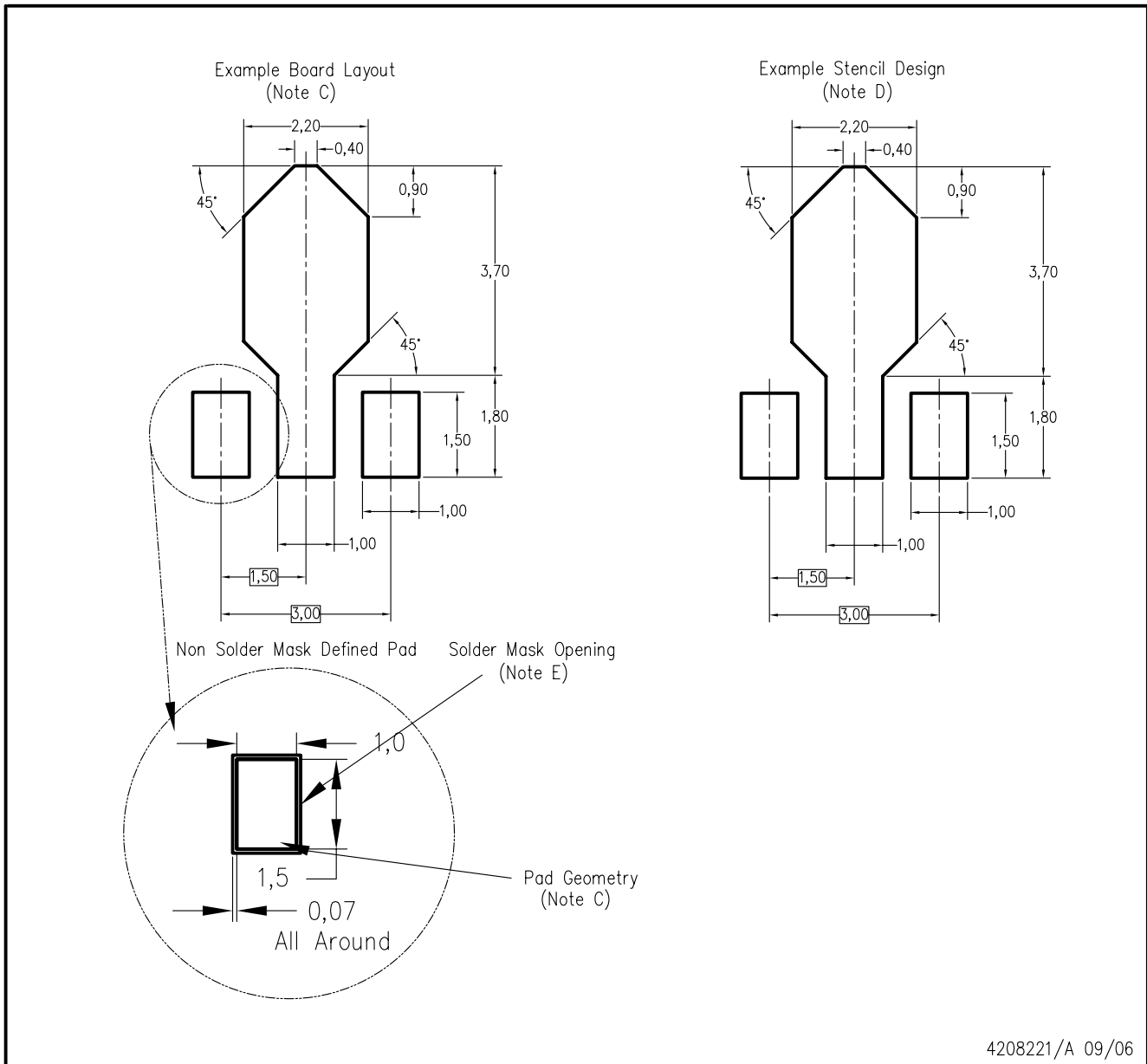

4208221/A 09/06

- NOTES:
- A. All linear dimensions are in millimeters.
 - B. This drawing is subject to change without notice.
 - C. Publication IPC-7351 is recommended for alternate designs.
 - D. Laser cutting apertures with trapezoidal walls and also rounding corners will offer better paste release. Customers should contact their board assembly site for stencil design recommendations. Refer to IPC-7525.
 - E. Customers should contact their board fabrication site for solder mask tolerances between and around signal pads.

DCK (R-PDSO-G6)

PLASTIC SMALL-OUTLINE PACKAGE

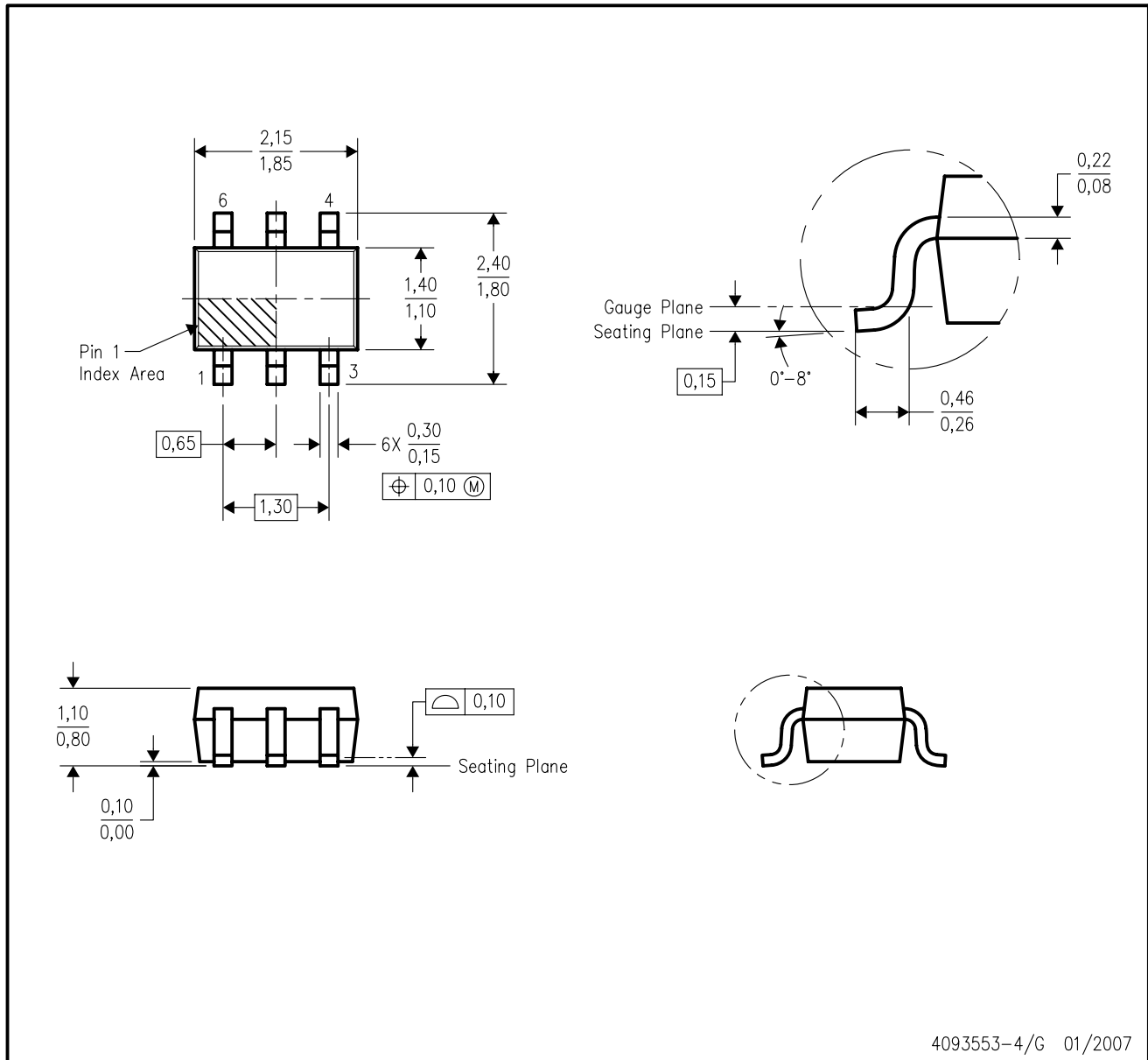

- NOTES:
- A. All linear dimensions are in millimeters.
 - B. This drawing is subject to change without notice.
 - C. Body dimensions do not include mold flash or protrusion. Mold flash and protrusion shall not exceed 0.15 per side.
 - D. Falls within JEDEC MO-203 variation AB.

DCK (R-PDSO-G6)

PLASTIC SMALL OUTLINE

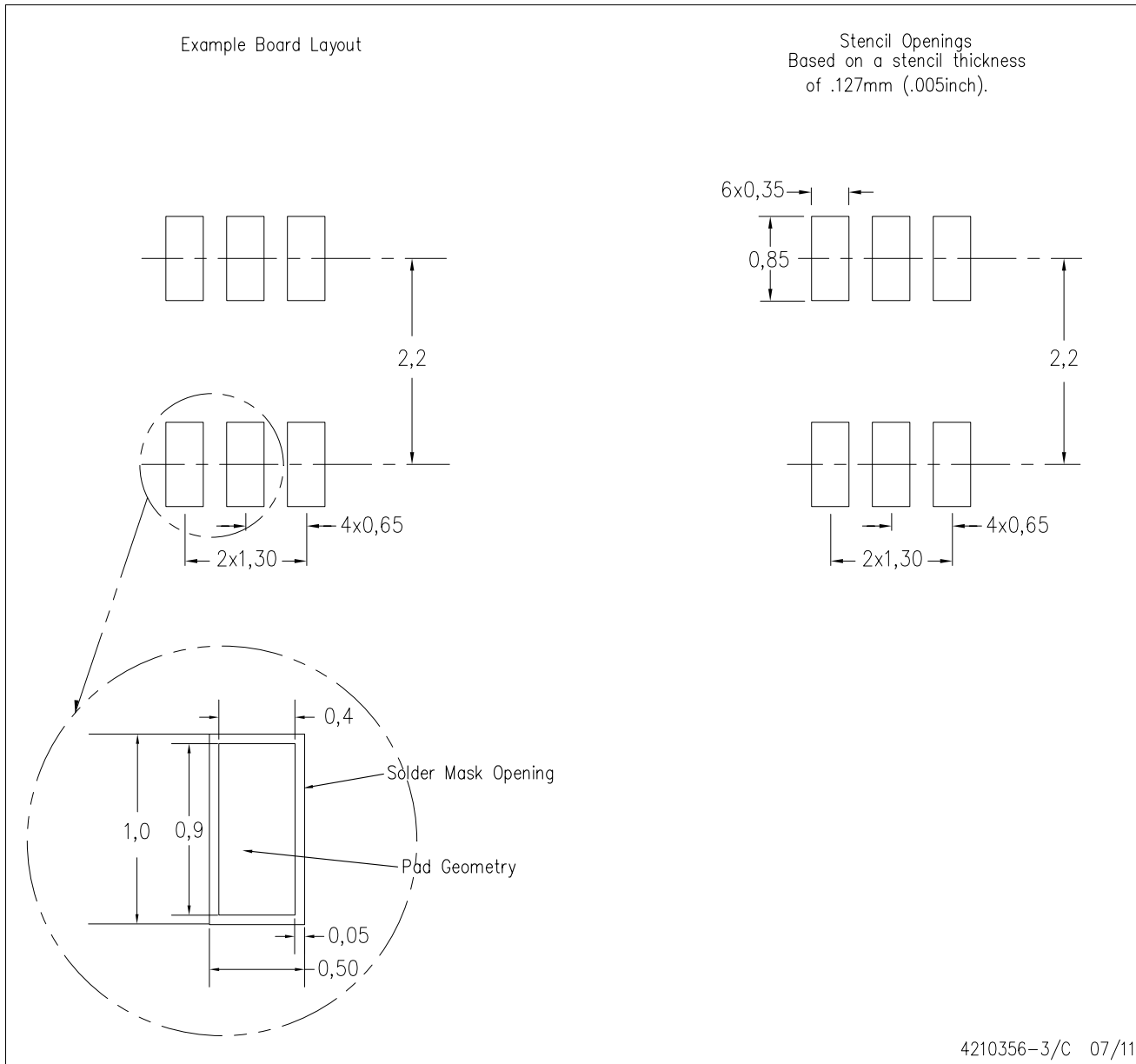

- NOTES:
- All linear dimensions are in millimeters.
 - This drawing is subject to change without notice.
 - Customers should place a note on the circuit board fabrication drawing not to alter the center solder mask defined pad.
 - Publication IPC-7351 is recommended for alternate designs.
 - Laser cutting apertures with trapezoidal walls and also rounding corners will offer better paste release. Customers should contact their board assembly site for stencil design recommendations. Example stencil design based on a 50% volumetric metal load solder paste. Refer to IPC-7525 for other stencil recommendations.



D0008A

PACKAGE OUTLINE

SOIC - 1.75 mm max height

SMALL OUTLINE INTEGRATED CIRCUIT



4214825/C 02/2019

NOTES:

1. Linear dimensions are in inches [millimeters]. Dimensions in parenthesis are for reference only. Controlling dimensions are in inches. Dimensioning and tolerancing per ASME Y14.5M.
2. This drawing is subject to change without notice.
3. This dimension does not include mold flash, protrusions, or gate burrs. Mold flash, protrusions, or gate burrs shall not exceed $.006$ [0.15] per side.
4. This dimension does not include interlead flash.
5. Reference JEDEC registration MS-012, variation AA.

EXAMPLE BOARD LAYOUT

D0008A

SOIC - 1.75 mm max height

SMALL OUTLINE INTEGRATED CIRCUIT



LAND PATTERN EXAMPLE
 EXPOSED METAL SHOWN
 SCALE:8X



SOLDER MASK DETAILS

4214825/C 02/2019

NOTES: (continued)

- 6. Publication IPC-7351 may have alternate designs.
- 7. Solder mask tolerances between and around signal pads can vary based on board fabrication site.

EXAMPLE STENCIL DESIGN

D0008A

SOIC - 1.75 mm max height

SMALL OUTLINE INTEGRATED CIRCUIT



SOLDER PASTE EXAMPLE
BASED ON .005 INCH [0.125 MM] THICK STENCIL
SCALE:8X

4214825/C 02/2019

NOTES: (continued)

8. Laser cutting apertures with trapezoidal walls and rounded corners may offer better paste release. IPC-7525 may have alternate design recommendations.
9. Board assembly site may have different recommendations for stencil design.

MECHANICAL DATA

PS (R-PDSO-G8)

PLASTIC SMALL-OUTLINE PACKAGE

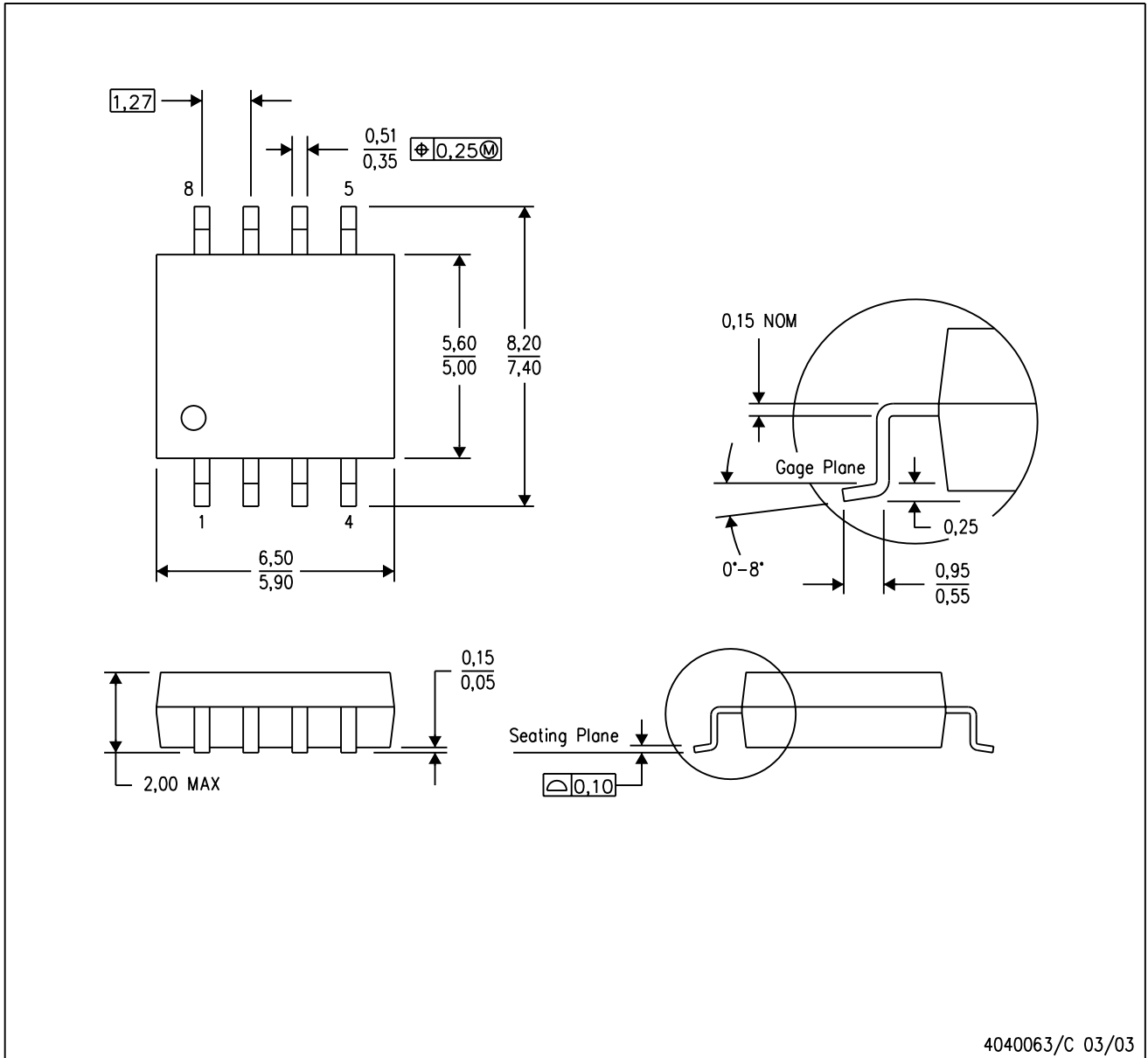

- NOTES:
- A. All linear dimensions are in millimeters.
 - B. This drawing is subject to change without notice.
 - C. Body dimensions do not include mold flash or protrusion, not to exceed 0,15.

PS (R-PDSO-G8)

PLASTIC SMALL OUTLINE



- NOTES:
- A. All linear dimensions are in millimeters.
 - B. This drawing is subject to change without notice.
 - C. Publication IPC-7351 is recommended for alternate designs.
 - D. Laser cutting apertures with trapezoidal walls and also rounding corners will offer better paste release. Customers should contact their board assembly site for stencil design recommendations. Refer to IPC-7525 for other stencil recommendations.
 - E. Customers should contact their board fabrication site for solder mask tolerances between and around signal pads.

P (R-PDIP-T8)

PLASTIC DUAL-IN-LINE PACKAGE



- NOTES:
- A. All linear dimensions are in inches (millimeters).
 - B. This drawing is subject to change without notice.
 - C. Falls within JEDEC MS-001 variation BA.

PW0008A



PACKAGE OUTLINE

TSSOP - 1.2 mm max height

SMALL OUTLINE PACKAGE

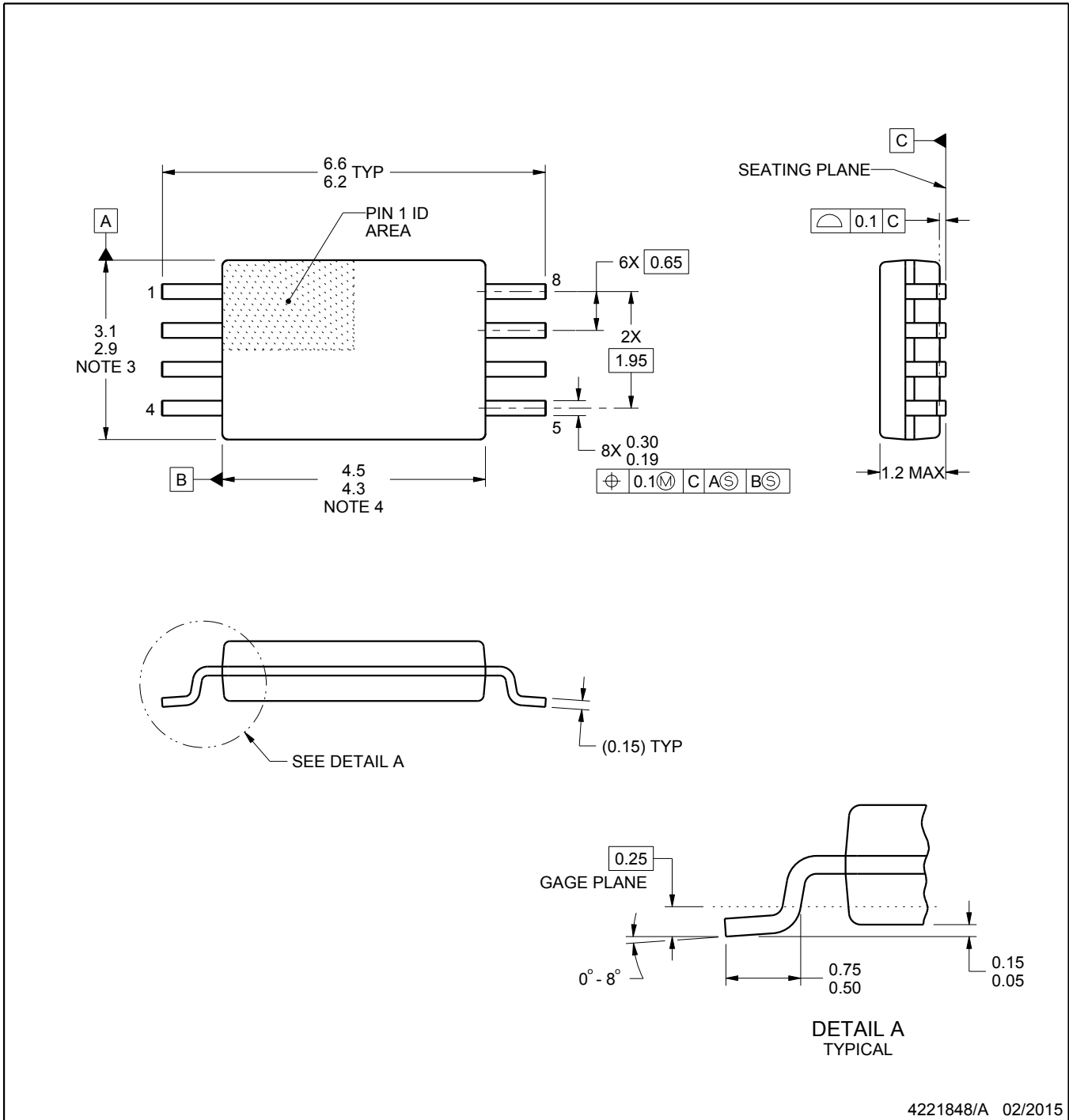

4221848/A 02/2015

NOTES:

- All linear dimensions are in millimeters. Any dimensions in parenthesis are for reference only. Dimensioning and tolerancing per ASME Y14.5M.
- This drawing is subject to change without notice.
- This dimension does not include mold flash, protrusions, or gate burrs. Mold flash, protrusions, or gate burrs shall not exceed 0.15 mm per side.
- This dimension does not include interlead flash. Interlead flash shall not exceed 0.25 mm per side.
- Reference JEDEC registration MO-153, variation AA.

EXAMPLE BOARD LAYOUT

PW0008A

TSSOP - 1.2 mm max height

SMALL OUTLINE PACKAGE

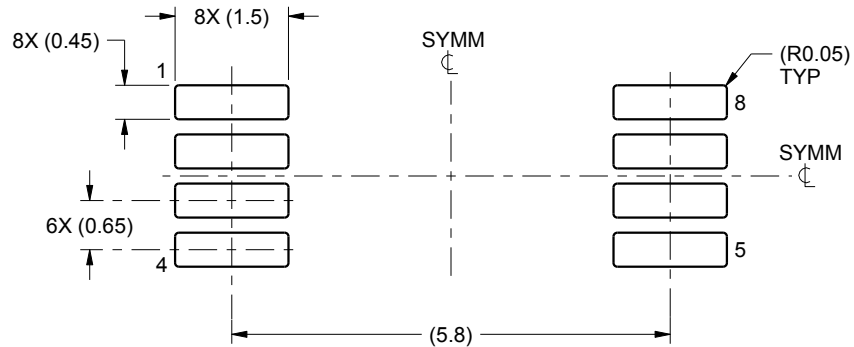

LAND PATTERN EXAMPLE
SCALE:10X



SOLDER MASK DETAILS
NOT TO SCALE

4221848/A 02/2015

NOTES: (continued)

- 6. Publication IPC-7351 may have alternate designs.
- 7. Solder mask tolerances between and around signal pads can vary based on board fabrication site.

EXAMPLE STENCIL DESIGN

PW0008A

TSSOP - 1.2 mm max height

SMALL OUTLINE PACKAGE



SOLDER PASTE EXAMPLE
BASED ON 0.125 mm THICK STENCIL
SCALE:10X

4221848/A 02/2015

NOTES: (continued)

8. Laser cutting apertures with trapezoidal walls and rounded corners may offer better paste release. IPC-7525 may have alternate design recommendations.
9. Board assembly site may have different recommendations for stencil design.

GENERIC PACKAGE VIEW

LP 3

TO-92 - 5.34 mm max height

TRANSISTOR OUTLINE



Images above are just a representation of the package family, actual package may vary.
Refer to the product data sheet for package details.

4040001-2/F

LP0003A



PACKAGE OUTLINE

TO-92 - 5.34 mm max height

TO-92



4215214/B 04/2017

NOTES:

1. All linear dimensions are in millimeters. Any dimensions in parenthesis are for reference only. Dimensioning and tolerancing per ASME Y14.5M.
2. This drawing is subject to change without notice.
3. Lead dimensions are not controlled within this area.
4. Reference JEDEC TO-226, variation AA.
5. Shipping method:
 - a. Straight lead option available in bulk pack only.
 - b. Formed lead option available in tape and reel or ammo pack.
 - c. Specific products can be offered in limited combinations of shipping medium and lead options.
 - d. Consult product folder for more information on available options.

EXAMPLE BOARD LAYOUT

LP0003A

TO-92 - 5.34 mm max height

TO-92

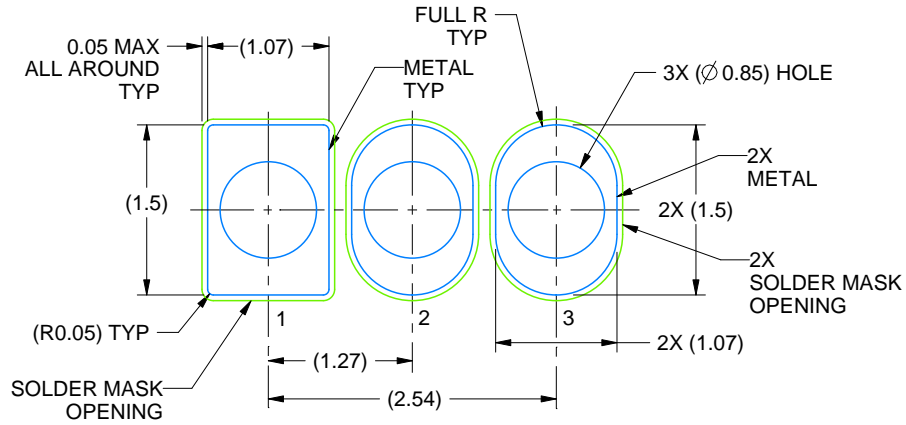

LAND PATTERN EXAMPLE
STRAIGHT LEAD OPTION
NON-SOLDER MASK DEFINED
SCALE:15X



LAND PATTERN EXAMPLE
FORMED LEAD OPTION
NON-SOLDER MASK DEFINED
SCALE:15X

4215214/B 04/2017

TAPE SPECIFICATIONS

LP0003A

TO-92 - 5.34 mm max height

TO-92

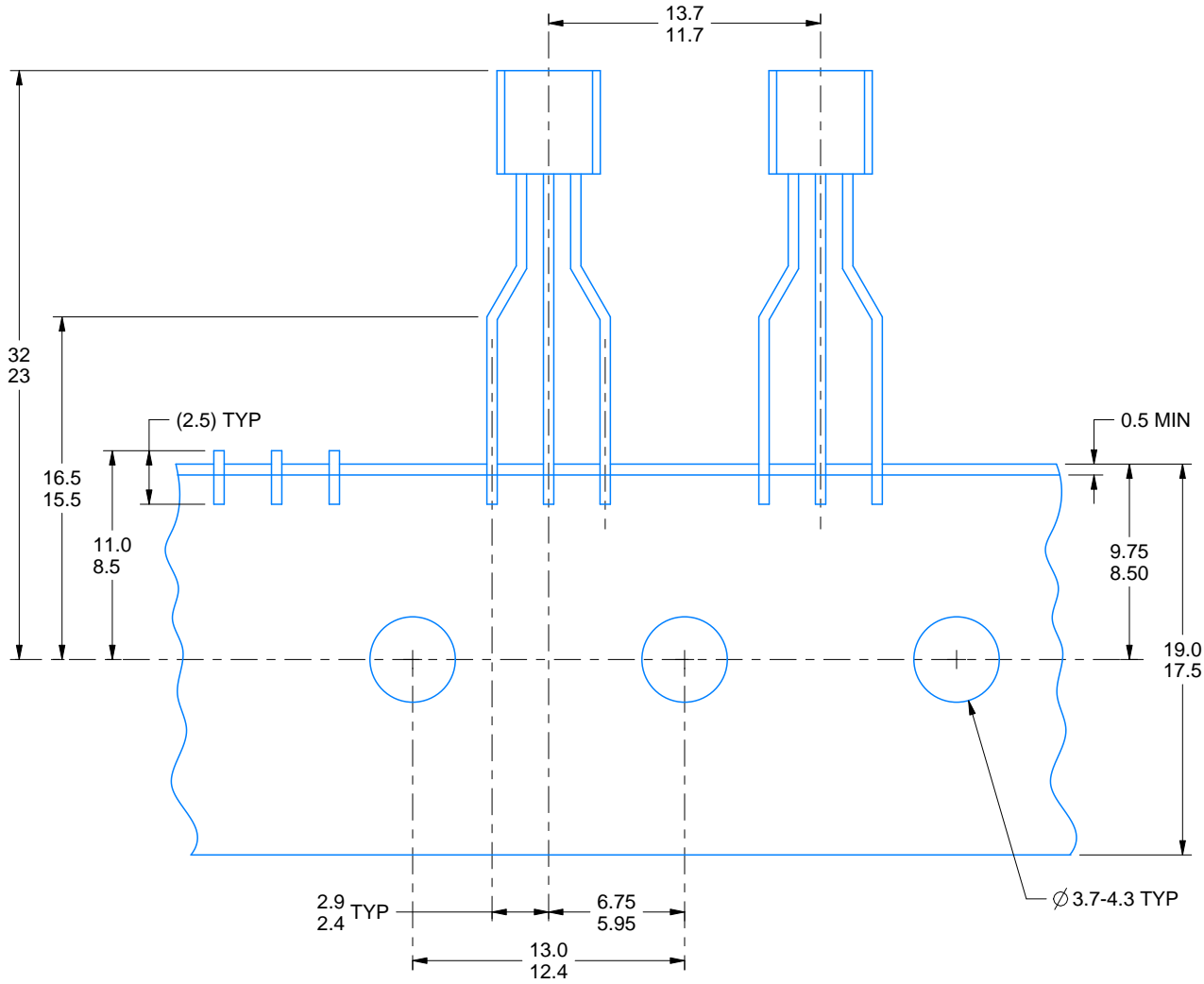

FOR FORMED LEAD OPTION PACKAGE

4215214/B 04/2017

重要声明和免责声明

TI“按原样”提供技术和可靠性数据（包括数据表）、设计资源（包括参考设计）、应用或其他设计建议、网络工具、安全信息和其他资源，不保证没有瑕疵且不做任何明示或暗示的担保，包括但不限于对适销性、某特定用途方面的适用性或不侵犯任何第三方知识产权的暗示担保。

这些资源可供使用 TI 产品进行设计的熟练开发人员使用。您将自行承担以下全部责任：(1) 针对您的应用选择合适的 TI 产品，(2) 设计、验证并测试您的应用，(3) 确保您的应用满足相应标准以及任何其他功能安全、信息安全、监管或其他要求。

这些资源如有变更，恕不另行通知。TI 授权您仅可将这些资源用于研发本资源所述的 TI 产品的应用。严禁对这些资源进行其他复制或展示。您无权使用任何其他 TI 知识产权或任何第三方知识产权。您应全额赔偿因在这些资源的使用中对 TI 及其代表造成的任何索赔、损害、成本、损失和债务，TI 对此概不负责。

TI 提供的产品受 [TI 的销售条款](#) 或 [ti.com](#) 上其他适用条款/TI 产品随附的其他适用条款的约束。TI 提供这些资源并不会扩展或以其他方式更改 TI 针对 TI 产品发布的适用的担保或担保免责声明。

TI 反对并拒绝您可能提出的任何其他或不同的条款。

邮寄地址：Texas Instruments, Post Office Box 655303, Dallas, Texas 75265

Copyright © 2022，德州仪器 (TI) 公司