

- Protects Against Latch-Up
- 25-mA Current Sink in Active State
- Less Than 1-mW Dissipation in Standby Condition
- Ideal for Applications in Environments Where Large Transient Spikes Occur
- Stable Operation for All Values of Capacitive Load
- No Output Overshoot

**D OR P PACKAGE
(TOP VIEW)**

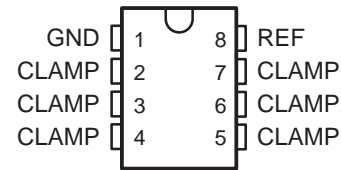

description

The TL7726 consists of six identical clamping circuits that monitor an input voltage with respect to a reference value, REF. For an input voltage (V_I) in the range of GND to $< REF$, the clamping circuits present a very high impedance to ground, drawing current of less than 10 μA . The clamping circuits are active for $V_I < GND$ or $V_I > REF$ when they have a very low impedance and can sink up to 25 mA.

These characteristics make the TL7726 ideal as protection devices for CMOS semiconductor devices in environments where there are large positive or negative transients to protect analog-to-digital converters in automotive or industrial systems. The use of clamping circuits provides a safeguard against potential latch-up.

The TL7726C is characterized for operation over the temperature range of 0°C to 70°C. The TL7726I is characterized for operation over the temperature range of -40°C to 85°C. The TL7726Q is characterized for operation over the temperature range of -40°C to 125°C.

AVAILABLE OPTIONS

T_A	SOIC (D)	PLASTIC DIP (P)
0°C to 70°C	TL7726CD	TL7726CP
-40°C to 85°C	TL7726ID	TL7726IP
-40°C to 125°C	TL7726QD	TL7726QP

The D package is available taped and reeled. Add the suffix R to the device type (i.e., TL7726CDR).



Please be aware that an important notice concerning availability, standard warranty, and use in critical applications of Texas Instruments semiconductor products and disclaimers thereto appears at the end of this data sheet.

TL7726

HEX CLAMPING CIRCUITS

SLAS078C – SEPTEMBER 1993 – REVISED JULY 1999

absolute maximum ratings over operating free-air temperature (unless otherwise noted)†

Reference voltage, V_{ref}	6 V
Clamping current, I_{IK}	± 50 mA
Junction temperature, T_J	150°C
Package thermal impedance, θ_{JA} (see Notes 1 and 2): D package	97°C/W
P package	127°C/W
Lead temperature 1,6 mm (1/16 inch) from case for 10 seconds	260°C
Storage temperature range, T_{stg}	-65°C to 150°C

† Stresses beyond those listed under “absolute maximum ratings” may cause permanent damage to the device. These are stress ratings only, and functional operation of the device at these or any other conditions beyond those indicated under “recommended operating conditions” is not implied. Exposure to absolute-maximum-rated conditions for extended periods may affect device reliability.

- NOTES: 1. Maximum power dissipation is a function of $T_{J(max)}$, θ_{JA} , and T_A . The maximum allowable power dissipation at any allowable ambient temperature is $P_D = (T_{J(max)} - T_A)/\theta_{JA}$. Operating at the absolute maximum T_J of 150°C can impact reliability.
2. The package thermal impedance is calculated in accordance with JEDEC 51, except for through-hole packages, which use a trace length of zero.

recommended operating conditions

		MIN	MAX	UNIT
Reference voltage, V_{ref}		4.5	5.5	V
Input clamping current, I_{IK}	$V_I \geq V_{ref}$	25		mA
	$V_I \leq GND$	-25		
Operating free-air temperature range, T_A	TL7726C	0	70	°C
	TL7726I	-40	85	
	TL7726Q	-40	125	

electrical characteristics over recommended operating free-air temperature range (unless otherwise noted)

PARAMETER		TEST CONDITIONS	MIN	TYP‡	MAX	UNIT
V_{IK+}	Positive clamp voltage	$I_I = 20$ mA	V_{ref}		$V_{ref} + 200$	mV
V_{IK-}	Negative clamp voltage	$I_I = 20$ mA	-200		0	mV
I_Z	Reference current	$V_{ref} = 5$ V		25	60	μ A
I_I	Input current	$V_{ref} - 50$ mV $\leq V_I \leq V_{ref}$			10	μ A
		$GND \leq V_I \leq 50$ mV	-10			
		50 mV $\leq V_I \leq V_{ref} - 50$ mV	-1		1	

‡ All typical values are at $T_A = 25^\circ\text{C}$.

switching characteristics specified at $T_A = 25^\circ\text{C}$

PARAMETER		TEST CONDITIONS	MIN	MAX	UNIT
t_s	Settling time	$V_{I(system)} = \pm 13$ V, $R_I = 600 \Omega$, $t_t < 1 \mu\text{s}$, Measured at 10% to 90%, See Figure 1		30	μs



PARAMETER MEASUREMENT INFORMATION

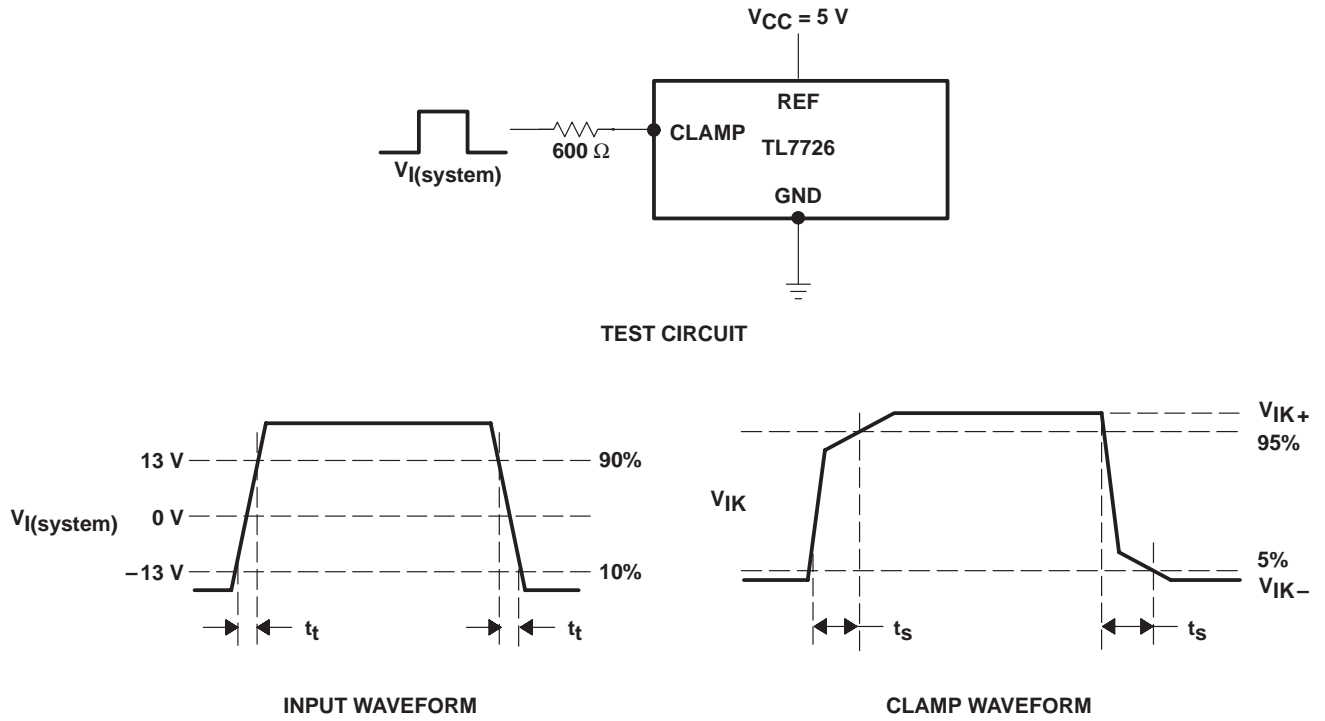

Figure 1. Switching Characteristics

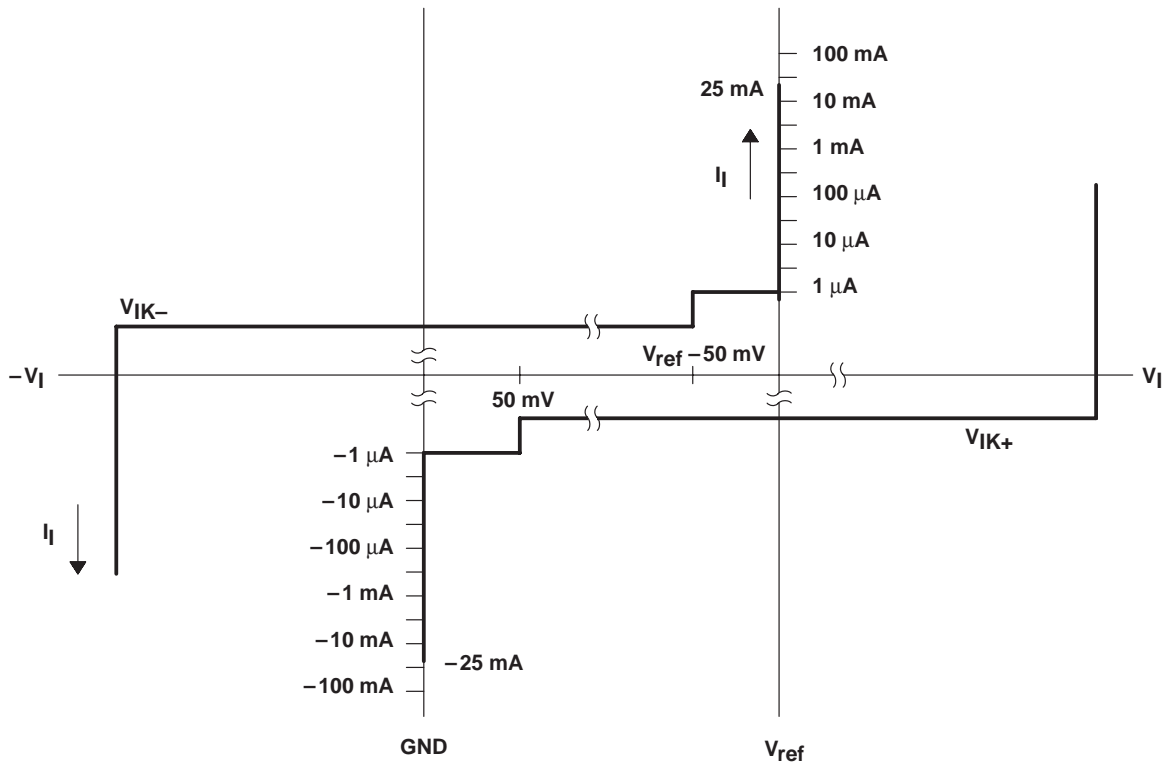
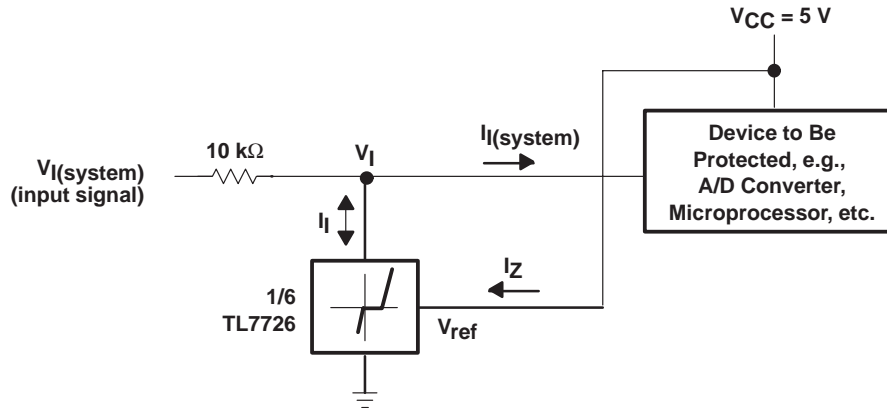

Figure 2. Tolerance Band for Clamping Circuit

TL7726 HEX CLAMPING CIRCUITS

SLAS078C – SEPTEMBER 1993 – REVISED JULY 1999

APPLICATION INFORMATION



Example: If $I_I \gg I_{I(\text{system})}$, i.e., $V_{I(\text{system})} > V_{\text{ref}} + 200 \text{ mV}$
where:

$I_{I(\text{system})}$ = Input current to the device being protected

$V_{I(\text{system})}$ = Input voltage to the device being protected
then the maximum input voltage

$$\begin{aligned} V_{I(\text{system})\text{max}} &= V_{\text{ref}} + I_{I\text{max}}(10\text{k}\Omega) \\ &= 5 \text{ V} + 25 \text{ mA}(10\text{k}\Omega) \\ &= 5 \text{ V} + 250 \text{ V} \\ &= 255 \text{ V} \end{aligned}$$

Figure 3. Typical Application

PACKAGING INFORMATION

Orderable Device	Status (1)	Package Type	Package Drawing	Pins	Package Qty	Eco Plan (2)	Lead finish/ Ball material (6)	MSL Peak Temp (3)	Op Temp (°C)	Device Marking (4/5)	Samples
TL7726CD	ACTIVE	SOIC	D	8	75	RoHS & Green	NIPDAU	Level-1-260C-UNLIM	0 to 70	7726C	Samples
TL7726CDE4	ACTIVE	SOIC	D	8	75	RoHS & Green	NIPDAU	Level-1-260C-UNLIM	0 to 70	7726C	Samples
TL7726CDR	ACTIVE	SOIC	D	8	2500	RoHS & Green	NIPDAU	Level-1-260C-UNLIM	0 to 70	7726C	Samples
TL7726CP	ACTIVE	PDIP	P	8	50	RoHS & Green	NIPDAU	N / A for Pkg Type	0 to 70	TL7726CP	Samples
TL7726ID	ACTIVE	SOIC	D	8	75	RoHS & Green	NIPDAU	Level-1-260C-UNLIM	-40 to 85	7726I	Samples
TL7726IDR	ACTIVE	SOIC	D	8	2500	RoHS & Green	NIPDAU	Level-1-260C-UNLIM	-40 to 85	7726I	Samples
TL7726IP	ACTIVE	PDIP	P	8	50	RoHS & Green	NIPDAU	N / A for Pkg Type	-40 to 85	TL7726IP	Samples
TL7726IPE4	ACTIVE	PDIP	P	8	50	RoHS & Green	NIPDAU	N / A for Pkg Type	-40 to 85	TL7726IP	Samples
TL7726QD	ACTIVE	SOIC	D	8	75	RoHS & Green	NIPDAU	Level-1-260C-UNLIM	-40 to 125	7726Q	Samples
TL7726QDG4	ACTIVE	SOIC	D	8	75	RoHS & Green	NIPDAU	Level-1-260C-UNLIM		7726Q	Samples
TL7726QDR	ACTIVE	SOIC	D	8	2500	RoHS & Green	NIPDAU	Level-1-260C-UNLIM	-40 to 125	7726Q	Samples
TL7726QDRG4	ACTIVE	SOIC	D	8	2500	RoHS & Green	NIPDAU	Level-1-260C-UNLIM		7726Q	Samples

(1) The marketing status values are defined as follows:

ACTIVE: Product device recommended for new designs.

LIFEBUY: TI has announced that the device will be discontinued, and a lifetime-buy period is in effect.

NRND: Not recommended for new designs. Device is in production to support existing customers, but TI does not recommend using this part in a new design.

PREVIEW: Device has been announced but is not in production. Samples may or may not be available.

OBSOLETE: TI has discontinued the production of the device.

(2) **RoHS:** TI defines "RoHS" to mean semiconductor products that are compliant with the current EU RoHS requirements for all 10 RoHS substances, including the requirement that RoHS substance do not exceed 0.1% by weight in homogeneous materials. Where designed to be soldered at high temperatures, "RoHS" products are suitable for use in specified lead-free processes. TI may reference these types of products as "Pb-Free".

RoHS Exempt: TI defines "RoHS Exempt" to mean products that contain lead but are compliant with EU RoHS pursuant to a specific EU RoHS exemption.

Green: TI defines "Green" to mean the content of Chlorine (Cl) and Bromine (Br) based flame retardants meet JS709B low halogen requirements of <=1000ppm threshold. Antimony trioxide based flame retardants must also meet the <=1000ppm threshold requirement.

- (3) MSL, Peak Temp. - The Moisture Sensitivity Level rating according to the JEDEC industry standard classifications, and peak solder temperature.
- (4) There may be additional marking, which relates to the logo, the lot trace code information, or the environmental category on the device.
- (5) Multiple Device Markings will be inside parentheses. Only one Device Marking contained in parentheses and separated by a "-" will appear on a device. If a line is indented then it is a continuation of the previous line and the two combined represent the entire Device Marking for that device.
- (6) Lead finish/Ball material - Orderable Devices may have multiple material finish options. Finish options are separated by a vertical ruled line. Lead finish/Ball material values may wrap to two lines if the finish value exceeds the maximum column width.

Important Information and Disclaimer:The information provided on this page represents TI's knowledge and belief as of the date that it is provided. TI bases its knowledge and belief on information provided by third parties, and makes no representation or warranty as to the accuracy of such information. Efforts are underway to better integrate information from third parties. TI has taken and continues to take reasonable steps to provide representative and accurate information but may not have conducted destructive testing or chemical analysis on incoming materials and chemicals. TI and TI suppliers consider certain information to be proprietary, and thus CAS numbers and other limited information may not be available for release.

In no event shall TI's liability arising out of such information exceed the total purchase price of the TI part(s) at issue in this document sold by TI to Customer on an annual basis.

TAPE AND REEL INFORMATION

QUADRANT ASSIGNMENTS FOR PIN 1 ORIENTATION IN TAPE

*All dimensions are nominal

Device	Package Type	Package Drawing	Pins	SPQ	Reel Diameter (mm)	Reel Width W1 (mm)	A0 (mm)	B0 (mm)	K0 (mm)	P1 (mm)	W (mm)	Pin1 Quadrant
TL7726CDR	SOIC	D	8	2500	330.0	12.4	6.4	5.2	2.1	8.0	12.0	Q1
TL7726IDR	SOIC	D	8	2500	330.0	12.4	6.4	5.2	2.1	8.0	12.0	Q1
TL7726QDR	SOIC	D	8	2500	330.0	12.4	6.4	5.2	2.1	8.0	12.0	Q1
TL7726QDRG4	SOIC	D	8	2500	330.0	12.4	6.4	5.2	2.1	8.0	12.0	Q1

TAPE AND REEL BOX DIMENSIONS

*All dimensions are nominal

Device	Package Type	Package Drawing	Pins	SPQ	Length (mm)	Width (mm)	Height (mm)
TL7726CDR	SOIC	D	8	2500	340.5	336.1	25.0
TL7726IDR	SOIC	D	8	2500	340.5	336.1	25.0
TL7726QDR	SOIC	D	8	2500	350.0	350.0	43.0
TL7726QDRG4	SOIC	D	8	2500	350.0	350.0	43.0

TUBE

*All dimensions are nominal

Device	Package Name	Package Type	Pins	SPQ	L (mm)	W (mm)	T (μm)	B (mm)
TL7726CD	D	SOIC	8	75	507	8	3940	4.32
TL7726CDE4	D	SOIC	8	75	507	8	3940	4.32
TL7726CP	P	PDIP	8	50	506	13.97	11230	4.32
TL7726ID	D	SOIC	8	75	507	8	3940	4.32
TL7726IP	P	PDIP	8	50	506	13.97	11230	4.32
TL7726IPE4	P	PDIP	8	50	506	13.97	11230	4.32
TL7726QD	D	SOIC	8	75	505.46	6.76	3810	4
TL7726QDG4	D	SOIC	8	75	505.46	6.76	3810	4



D0008A

PACKAGE OUTLINE

SOIC - 1.75 mm max height

SMALL OUTLINE INTEGRATED CIRCUIT



4214825/C 02/2019

NOTES:

1. Linear dimensions are in inches [millimeters]. Dimensions in parenthesis are for reference only. Controlling dimensions are in inches. Dimensioning and tolerancing per ASME Y14.5M.
2. This drawing is subject to change without notice.
3. This dimension does not include mold flash, protrusions, or gate burrs. Mold flash, protrusions, or gate burrs shall not exceed $.006$ [0.15] per side.
4. This dimension does not include interlead flash.
5. Reference JEDEC registration MS-012, variation AA.

EXAMPLE BOARD LAYOUT

D0008A

SOIC - 1.75 mm max height

SMALL OUTLINE INTEGRATED CIRCUIT



LAND PATTERN EXAMPLE
 EXPOSED METAL SHOWN
 SCALE:8X



SOLDER MASK DETAILS

4214825/C 02/2019

NOTES: (continued)

- 6. Publication IPC-7351 may have alternate designs.
- 7. Solder mask tolerances between and around signal pads can vary based on board fabrication site.

EXAMPLE STENCIL DESIGN

D0008A

SOIC - 1.75 mm max height

SMALL OUTLINE INTEGRATED CIRCUIT



SOLDER PASTE EXAMPLE
BASED ON .005 INCH [0.125 MM] THICK STENCIL
SCALE:8X

4214825/C 02/2019

NOTES: (continued)

8. Laser cutting apertures with trapezoidal walls and rounded corners may offer better paste release. IPC-7525 may have alternate design recommendations.
9. Board assembly site may have different recommendations for stencil design.

P (R-PDIP-T8)

PLASTIC DUAL-IN-LINE PACKAGE



4040082/E 04/2010

- NOTES:
- A. All linear dimensions are in inches (millimeters).
 - B. This drawing is subject to change without notice.
 - C. Falls within JEDEC MS-001 variation BA.

IMPORTANT NOTICE AND DISCLAIMER

TI PROVIDES TECHNICAL AND RELIABILITY DATA (INCLUDING DATA SHEETS), DESIGN RESOURCES (INCLUDING REFERENCE DESIGNS), APPLICATION OR OTHER DESIGN ADVICE, WEB TOOLS, SAFETY INFORMATION, AND OTHER RESOURCES "AS IS" AND WITH ALL FAULTS, AND DISCLAIMS ALL WARRANTIES, EXPRESS AND IMPLIED, INCLUDING WITHOUT LIMITATION ANY IMPLIED WARRANTIES OF MERCHANTABILITY, FITNESS FOR A PARTICULAR PURPOSE OR NON-INFRINGEMENT OF THIRD PARTY INTELLECTUAL PROPERTY RIGHTS.

These resources are intended for skilled developers designing with TI products. You are solely responsible for (1) selecting the appropriate TI products for your application, (2) designing, validating and testing your application, and (3) ensuring your application meets applicable standards, and any other safety, security, regulatory or other requirements.

These resources are subject to change without notice. TI grants you permission to use these resources only for development of an application that uses the TI products described in the resource. Other reproduction and display of these resources is prohibited. No license is granted to any other TI intellectual property right or to any third party intellectual property right. TI disclaims responsibility for, and you will fully indemnify TI and its representatives against, any claims, damages, costs, losses, and liabilities arising out of your use of these resources.

TI's products are provided subject to [TI's Terms of Sale](#) or other applicable terms available either on ti.com or provided in conjunction with such TI products. TI's provision of these resources does not expand or otherwise alter TI's applicable warranties or warranty disclaimers for TI products.

TI objects to and rejects any additional or different terms you may have proposed.

Mailing Address: Texas Instruments, Post Office Box 655303, Dallas, Texas 75265
Copyright © 2022, Texas Instruments Incorporated