

TLC193, TLC393 DUAL MICROPOWER LinCMOS™ VOLTAGE COMPARATOR

SLCS115E – DECEMBER 1986 – REVISED JULY 2003

- Very Low Power . . . 110 μ W Typ at 5 V
- Fast Response Time . . . $t_{PLH} = 2.5 \mu$ s Typ With 5-mV Overdrive
- Single Supply Operation:
 - TLC393C . . . 3 V to 16 V
 - TLC393I . . . 3 V to 16 V
 - TLC393Q . . . 4 V to 16 V
 - TLC393M . . . 4 V to 16 V
 - TLC193M . . . 4 V to 16 V
- On-Chip ESD Protection

description

The TLC193 and TLC393 consist of dual independent micropower voltage comparators designed to operate from a single supply. They are functionally similar to the LM393 but uses one-twentieth the power for similar response times. The open-drain MOS output stage interfaces to a variety of loads and supplies. For a similar device with a push-pull output configuration (see the TLC3702 data sheet).

Texas Instruments LinCMOS™ process offers superior analog performance to standard CMOS processes. Along with the standard CMOS advantages of low power without sacrificing speed, high input impedance, and low bias currents, the LinCMOS™ process offers extremely stable input offset voltages, even with differential input stresses of several volts. This characteristic makes it possible to build reliable CMOS comparators.

The TLC393C is characterized for operation over the commercial temperature range of $T_A = 0^\circ\text{C}$ to 70°C . The TLC393I is characterized for operation over the extended industrial temperature range of $T_A = -40^\circ\text{C}$ to 85°C . The TLC393Q is characterized for operation over the full automotive temperature range of $T_A = -40^\circ\text{C}$ to 125°C . The TLC193M and TLC393M are characterized for operation over the full military temperature range of $T_A = -55^\circ\text{C}$ to 125°C .

D, JG, P, OR PW PACKAGE
(TOP VIEW)

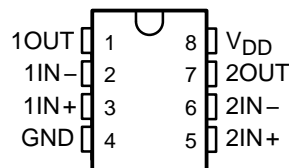

FK PACKAGE
(TOP VIEW)

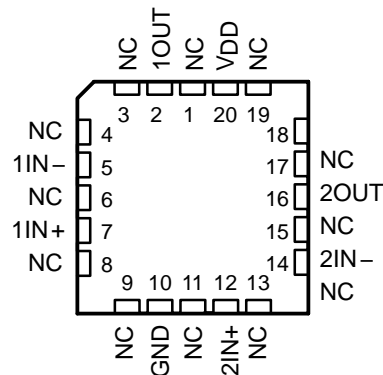

NC – No internal connection

symbol (each comparator)

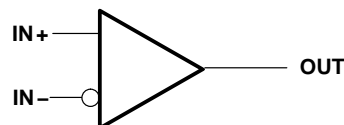

Please be aware that an important notice concerning availability, standard warranty, and use in critical applications of Texas Instruments semiconductor products and disclaimers thereto appears at the end of this data sheet.

LinCMOS is a trademark of Texas Instruments Incorporated. All other trademarks are the property of their respective owners.

PRODUCTION DATA information is current as of publication date. Products conform to specifications per the terms of Texas Instruments standard warranty. Production processing does not necessarily include testing of all parameters.

**TEXAS
INSTRUMENTS**

POST OFFICE BOX 655303 • DALLAS, TEXAS 75265
POST OFFICE BOX 1443 • HOUSTON, TEXAS 77251-1443

Copyright © 1986-2003, Texas Instruments Incorporated

TLC193, TLC393

DUAL MICROWPOWER LinCMOS™ VOLTAGE COMPARATOR

SLCS115D – DECEMBER 1986 – REVISED JULY 2003

AVAILABLE OPTIONS

T _A	V _{IOmax} at 25°C	PACKAGES				
		SMALL OUTLINE (D)	CHIP CARRIER (FK)	CERAMIC DIP (JG)	PLASTIC DIP (P)	TSSOP (PW)
0°C to 70°C	5 mV	TLC393CD	—	—	TLC393CP	TLC393CPWLE
– 40°C to 85°C	5 mV	TLC393ID	—	—	TLC393IP	TLC393IPWLE
– 40°C to 125°C	5 mV	TLC393QD	—	—	—	—
– 55°C to 125°C	5 mV	TLC393MD	TLC193MFK	TLC193MJG	TLC393MP	—

The D package is available taped and reeled. Add the suffix R to the device type (e.g., TLC393CDR).

schematic

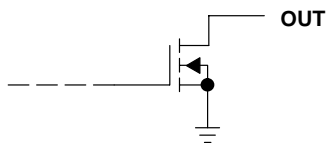

OPEN-DRAIN CMOS OUTPUT

absolute maximum ratings over operating free-air temperature range (unless otherwise noted)†

Supply voltage range, V _{DD} (see Note 1)	– 0.3 V to 18 V
Differential input voltage, V _{ID} (see Note 2)	±18 V
Input voltage range, V _I	– 0.3 V to V _{DD}
Output voltage range, V _O	– 0.3 V to 16 V
Input current, I _I	±5 mA
Output current, I _O (each output)	20 mA
Total supply current into V _{DD}	40 mA
Total current out of GND	40 mA
Continuous total power dissipation	See Dissipation Rating Table
Operating free-air temperature range:	
TLC393C	0°C to 70°C
TLC393I	– 40°C to 85°C
TLC393Q	– 40°C to 125°C
TLC393M	– 55°C to 125°C
TLC193M	– 55°C to 125°C
Storage temperature range	– 65°C to 150°C
Case temperature for 60 seconds: FK package	260°C
Lead temperature 1,6 mm (1/16 inch) from case for 10 seconds: D or P package	260°C
Lead temperature 1,6 mm (1/16 inch) from case for 60 seconds: JG package	300°C

† Stresses beyond those listed under “absolute maximum ratings” may cause permanent damage to the device. These are stress ratings only, and functional operation of the device at these or any other conditions beyond those indicated under “recommended operating conditions” is not implied. Exposure to absolute-maximum-rated conditions for extended periods may affect device reliability.

- NOTES: 1. All voltage values, except differential voltages, are with respect to network ground.
2. Differential voltages are at IN+ with respect to IN–.

DISSIPATION RATING TABLE

PACKAGE	T _A ≤ 25°C POWER RATING	DERATING FACTOR ABOVE T _A = 25°C	T _A = 70°C POWER RATING	T _A = 85°C POWER RATING	T _A = 125°C POWER RATING
D	725 mW	5.8 mW/°C	464 mW	377 mW	145 mW
FK	1375 mW	11.0 mW/°C	880 mW	715 mW	275 mW
JG	1050 mW	8.4 mW/°C	672 mW	546 mW	210 mW
P	1000 mW	8.0 mW/°C	640 mW	520 mW	—
PW	525 mW	4.2 mW/°C	336 mW	273 mW	—



TLC193, TLC393

DUAL MICROPPOWER LinCMOS™ VOLTAGE COMPARATOR

SLCS115E – DECEMBER 1986 – REVISED JULY 2003

recommended operating conditions

	TLC393C			UNIT
	MIN	NOM	MAX	
Supply voltage, V_{DD}	3	5	16	V
Common-mode input voltage, V_{IC}	-0.2		$V_{DD} - 1.5$	V
Low-level output current, I_{OL}			20	mA
Operating free-air temperature, T_A	0		70	°C

electrical characteristics at specified operating free-air temperature, $V_{DD} = 5$ V (unless otherwise noted)

PARAMETER	TEST CONDITIONS†	T_A	TLC393C			UNIT
			MIN	TYP	MAX	
V_{IO} Input offset voltage	$V_{IC} = V_{ICRmin}$, $V_{DD} = 5$ V to 10 V, See Note 3	25°C		1.4	5	mV
		0°C to 70°C			6.5	
I_{IO} Input offset current	$V_{IC} = 2.5$ V	25°C		1		pA
		70°C			0.3	nA
I_{IB} Input bias current	$V_{IC} = 2.5$ V	25°C		5		pA
		70°C			0.6	nA
V_{ICR} Common-mode input voltage range		25°C	0 to $V_{DD} - 1$			V
		0°C to 70°C	0 to $V_{DD} - 1.5$			
CMMR Common-mode rejection ratio	$V_{IC} = V_{ICRmin}$	25°C	84			dB
		70°C	84			
		0°C	84			
k_{SVR} Supply-voltage rejection ratio	$V_{DD} = 5$ V to 10 V	25°C	85			dB
		70°C	85			
		0°C	85			
V_{OL} Low-level output voltage	$V_{ID} = -1$ V, $I_{OL} = 6$ mA	25°C		300	400	mV
		70°C			650	
I_{OH} High-level output current	$V_{ID} = 1$ V, $V_O = 5$ V	25°C		0.8	40	nA
		70°C			1	μA
I_{DD} Supply current (both comparators)	Outputs low, No load	25°C		22	40	μA
		0°C to 70°C			50	

† All characteristics are measured with zero common-mode voltage unless otherwise noted.

NOTE 3: The offset voltage limits given are the maximum values required to drive the output up to 4.5 V or down to 0.3 V.



TLC193, TLC393

DUAL MICROWPOWER LinCMOS™ VOLTAGE COMPARATOR

SLCS115D – DECEMBER 1986 – REVISED JULY 2003

recommended operating conditions

	TLC393I			UNIT
	MIN	NOM	MAX	
Supply voltage, V_{DD}	3	5	16	V
Common-mode input voltage, V_{IC}	-0.2		$V_{DD} - 1.5$	V
Low-level output current, I_{OL}			20	mA
Operating free-air temperature, T_A	-40		85	°C

electrical characteristics at specified operating free-air temperature, $V_{DD} = 5$ V (unless otherwise noted)

PARAMETER	TEST CONDITION†	T_A	TLC393I			UNIT
			MIN	TYP	MAX	
V_{IO} Input offset voltage	$V_{IC} = V_{ICRmin}$, $V_{DD} = 5$ V to 10 V, See Note 3	25°C		1.4	5	mV
		-40°C to 85°C			7	
I_{IO} Input offset current	$V_{IC} = 2.5$ V	25°C		1		pA
		85°C			1	nA
I_{IB} Input bias current	$V_{IC} = 2.5$ V	25°C		5		pA
		85°C			2	nA
V_{ICR} Common-mode input voltage range		25°C	0 to $V_{DD} - 1$			V
		-40°C to 85°C	0 to $V_{DD} - 1.5$			
CMMR Common-mode rejection ratio	$V_{IC} = V_{ICRmin}$	25°C	84			dB
		85°C	84			
		-40°C	84			
k_{SVR} Supply-voltage rejection ratio	$V_{DD} = 5$ V to 10 V	25°C	85			dB
		85°C	85			
		-40°C	84			
V_{OL} Low-level output voltage	$V_{ID} = -1$ V, $I_{OL} = 6$ mA	25°C	300	400		mV
		85°C	700			
I_{OH} High-level output current	$V_{ID} = 1$ V, $V_O = 5$ V	25°C	0.8		40	nA
		85°C	1			μA
I_{DD} Supply current (both comparators)	Outputs low, No load	25°C	22		40	μA
		-40°C to 85°C	65			

† All characteristics are measured with zero common-mode voltage unless otherwise noted.

NOTE 3: The offset voltage limits given are the maximum values required to drive the output up to 4.5 V or down to 0.3 V.



TLC193, TLC393

DUAL MICROPPOWER LinCMOS™ VOLTAGE COMPARATOR

SLCS115E – DECEMBER 1986 – REVISED JULY 2003

recommended operating conditions

	TLC393Q			UNIT
	MIN	NOM	MAX	
Supply voltage, V_{DD}	4	5	16	V
Common-mode input voltage, V_{IC}	0	$V_{DD} - 1.5$		V
Low-level output current, I_{OL}	20			mA
Operating free-air temperature, T_A	-40	125		°C

electrical characteristics at specified operating free-air temperature, $V_{DD} = 5$ V (unless otherwise noted)

PARAMETER	TEST CONDITION†	T_A	TLC393Q			UNIT
			MIN	TYP	MAX	
V_{IO} Input offset voltage	$V_{IC} = V_{ICRmin}$, $V_{DD} = 5$ V to 10 V, See Note 4	25°C	1.4		5	mV
		-40°C to 125°C	10			
I_{IO} Input offset current	$V_{IC} = 2.5$ V	25°C	1			pA
		125°C			15	nA
I_{IB} Input bias current	$V_{IC} = 2.5$ V	25°C	5			pA
		125°C			30	nA
V_{ICR} Common-mode input voltage range		25°C	0 to $V_{DD} - 1$			V
		-40°C to 125°C	0 to $V_{DD} - 1.5$			
CMMR Common-mode rejection ratio	$V_{IC} = V_{ICRmin}$	25°C	84			dB
		125°C	84			
		-40°C	84			
k_{SVR} Supply-voltage rejection ratio	$V_{DD} = 5$ V to 10 V	25°C	85			dB
		125°C	84			
		-40°C	84			
V_{OL} Low-level output voltage	$V_{ID} = -1$ V, $I_{OL} = 6$ mA	25°C	300	400		mV
		125°C	800			
I_{OH} High-level output current	$V_{ID} = 1$ V, $V_O = 5$ V	25°C	0.8	40		nA
		125°C	1			μA
I_{DD} Supply current (both comparators)	Outputs low, No load	25°C	22	40		μA
		-40°C to 125°C	90			

† All characteristics are measured with zero common-mode voltage unless otherwise noted.

NOTE 4: The offset voltage limits given are the maximum values required to drive the output up to 4.5 V or down to 0.3 V (with a 2.5-kΩ load to V_{DD}).



TLC193, TLC393

DUAL MICROWPOWER LinCMOS™ VOLTAGE COMPARATOR

SLCS115D – DECEMBER 1986 – REVISED JULY 2003

recommended operating conditions

	TLC193M, TLC393M			UNIT
	MIN	NOM	MAX	
Supply voltage, V_{DD}	4	5	16	V
Common-mode input voltage, V_{IC}	0		$V_{DD} - 1.5$	V
Low-level output current, I_{OL}			20	mA
Operating free-air temperature, T_A	-55		125	°C

electrical characteristics at specified operating free-air temperature, $V_{DD} = 5$ V (unless otherwise noted)

PARAMETER	TEST CONDITIONS†	T_A	TLC193M, TLC393M			UNIT
			MIN	TYP	MAX	
V_{IO} Input offset voltage	$V_{IC} = V_{ICRmin}$, $V_{DD} = 5$ V to 10 V, See Note 4	25°C		1.4	5	mV
		-55°C to 125°C			10	
I_{IO} Input offset current	$V_{IC} = 2.5$ V	25°C		1		pA
		125°C			15	nA
I_{IB} Input bias current	$V_{IC} = 2.5$ V	25°C		5		pA
		125°C			30	nA
V_{ICR} Common-mode input voltage range		25°C	0 to $V_{DD} - 1$			V
		-55°C to 125°C	0 to $V_{DD} - 1.5$			
CMMR Common-mode rejection ratio	$V_{IC} = V_{ICRmin}$	25°C	84			dB
		125°C	84			
		-55°C	84			
kSVR Supply-voltage rejection ratio	$V_{DD} = 5$ V to 10 V	25°C	85			dB
		125°C	84			
		-55°C	84			
V_{OL} Low-level output voltage	$V_{ID} = -1$ V, $I_{OL} = 6$ mA	25°C	300	400		mV
		125°C	800			
I_{OH} High-level output current	$V_{ID} = 1$ V, $V_O = 5$ V	25°C	0.8		40	nA
		125°C	1			μA
I_{DD} Supply current (both comparators)	Outputs low, No load	25°C	22		40	μA
		-55°C to 125°C	90			

† All characteristics are measured with zero common-mode voltage unless otherwise noted.

NOTE 4: The offset voltage limits given are the maximum values required to drive the output up to 4.5 V or down to 0.3 V (with a 2.5-kΩ load to V_{DD}).



TLC193, TLC393 DUAL MICROPOWER LinCMOS™ VOLTAGE COMPARATOR

SLCS115E – DECEMBER 1986 – REVISED JULY 2003

switching characteristics, $V_{DD} = 5\text{ V}$, $T_A = 25^\circ\text{C}$ (see Figure 3)

PARAMETER	TEST CONDITIONS	TLC393C, TLC393I TLC393Q, TLC193M, TLC393M			UNIT
		MIN	TYP	MAX	
t_{PLH} Propagation delay time, low-to-high-level output	$f = 10\text{ kHz}$, $C_L = 15\text{ pF}$	Overdrive = 2 mV	4.5		μs
		Overdrive = 5 mV	2.5		
		Overdrive = 10 mV	1.7		
		Overdrive = 20 mV	1.2		
		Overdrive = 40 mV	1.1		
t_{PHL} Propagation delay time, high-to-low-level output	$f = 10\text{ kHz}$, $C_L = 15\text{ pF}$	$V_I = 1.4\text{-V}$ step at IN+	1.1		μs
		Overdrive = 2 mV	3.6		
		Overdrive = 5 mV	2.1		
		Overdrive = 10 mV	1.3		
		Overdrive = 20 mV	0.85		
		Overdrive = 40 mV	0.55		
t_f Fall time, output	$f = 10\text{ kHz}$, $C_L = 15\text{ pF}$	$V_I = 1.4\text{-V}$ step at IN+	0.10		ns
		Overdrive = 50 mV	22		

PARAMETER MEASUREMENT INFORMATION

The TLC393 contains a digital output stage which, if held in the linear region of the transfer curve, can cause damage to the device. Conventional operational amplifier/comparator testing incorporates the use of a servo loop that is designed to force the device output to a level within this linear region. Since the servo-loop method of testing cannot be used, the following alternatives for testing parameters such as input offset voltage, common-mode rejection ratio, etc., are suggested.

To verify that the input offset voltage falls within the limits specified, the limit value is applied to the input as shown in Figure 1(a). With the noninverting input positive with respect to the inverting input, the output should be high. With the input polarity reversed, the output should be low.

A similar test can be made to verify the input offset voltage at the common-mode extremes. The supply voltages can be slewed as shown in Figure 1(b) for the V_{ICR} test, rather than changing the input voltages, to provide greater accuracy.

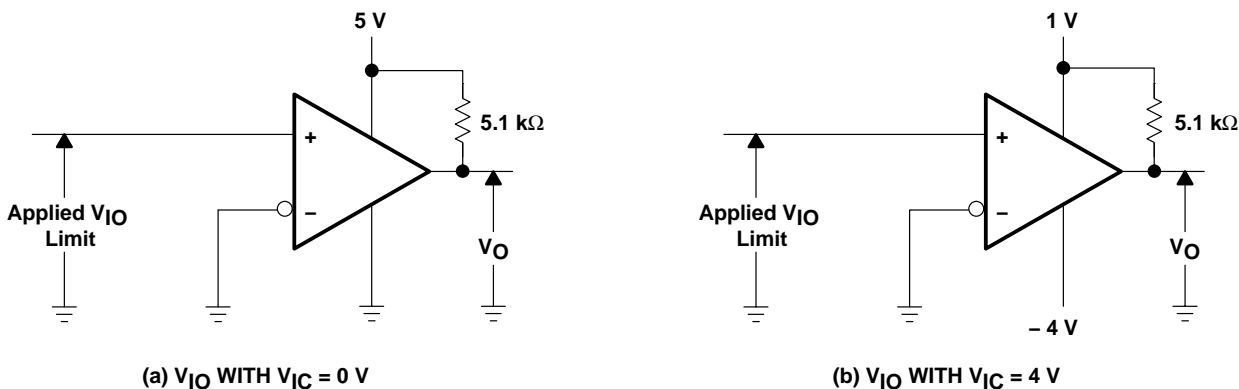

Figure 1. Method for Verifying That Input Offset Voltage Is Within Specified Limits



TLC193, TLC393 DUAL MICROWPOWER LinCMOS™ VOLTAGE COMPARATOR

SLCS115D – DECEMBER 1986 – REVISED JULY 2003

PARAMETER MEASUREMENT INFORMATION

A close approximation of the input offset voltage can be obtained by using a binary search method to vary the differential input voltage while monitoring the output state. When the applied input voltage differential is equal, but opposite in polarity, to the input offset voltage, the output changes states.

Figure 2 illustrates a practical circuit for direct dc measurement of input offset voltage that does not bias the comparator in the linear region. The circuit consists of a switching-mode servo loop in which U1A generates a triangular waveform of approximately 20-mV amplitude. U1B acts as a buffer, with C2 and R4 removing any residual dc offset. The signal is then applied to the inverting input of the comparator under test, while the noninverting input is driven by the output of the integrator formed by U1C through the voltage divider formed by R9 and R10. The loop reaches a stable operating point when the output of the comparator under test has a duty cycle of exactly 50%, which can only occur when the incoming triangle wave is sliced symmetrically or when the voltage at the noninverting input exactly equals the input offset voltage.

The voltage divider formed by R9 and R10 provides an increase in input offset voltage by a factor of 100 to make measurement easier. The values of R5, R8, R9, and R10 can significantly influence the accuracy of the reading; therefore, it is suggested that their tolerance level be 1% or lower.

Measuring the extremely low values of input current requires isolation from all other sources of leakage current and compensation for the leakage of the test socket and board. With a good picoammeter, the socket and board leakage can be measured with no device in the socket. Subsequently, this open-socket leakage value can be subtracted from the measurement obtained with a device in the socket to obtain the actual input current of the device.

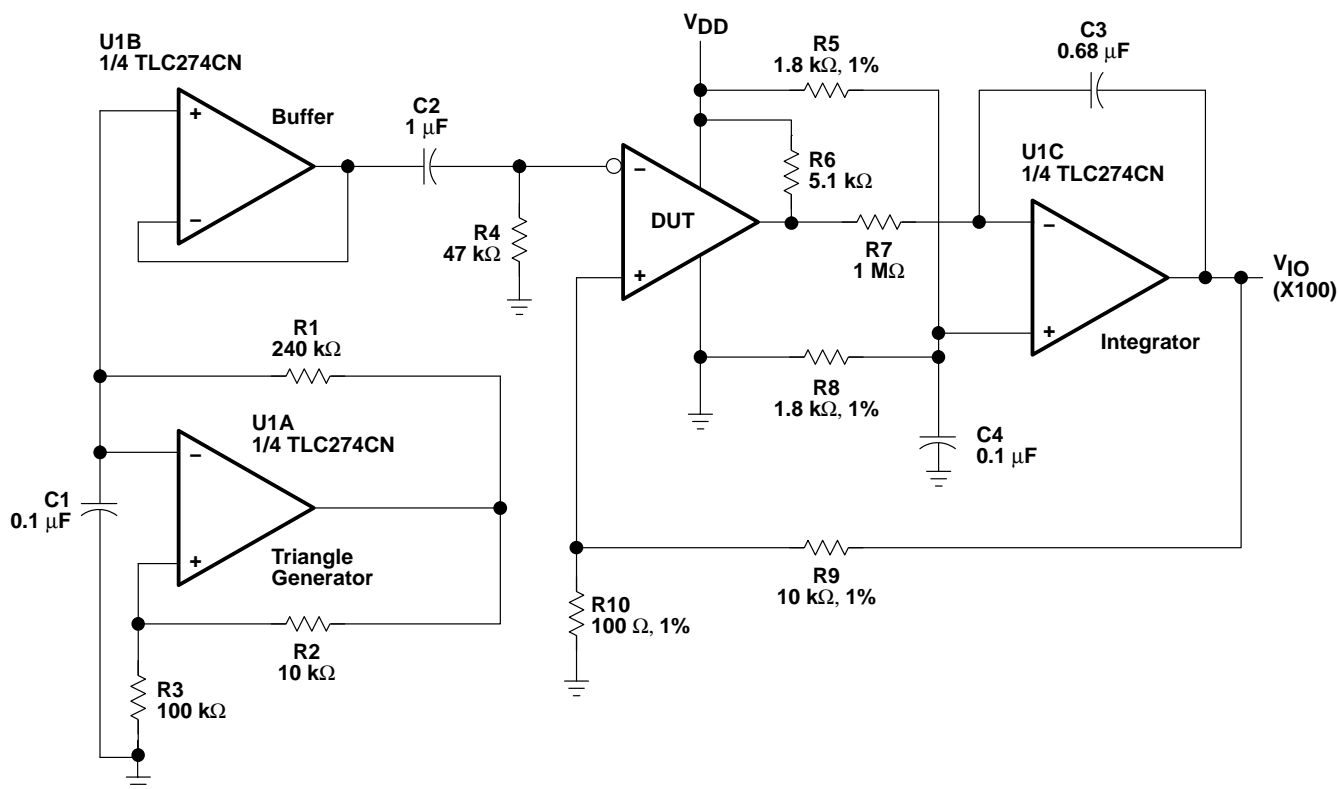
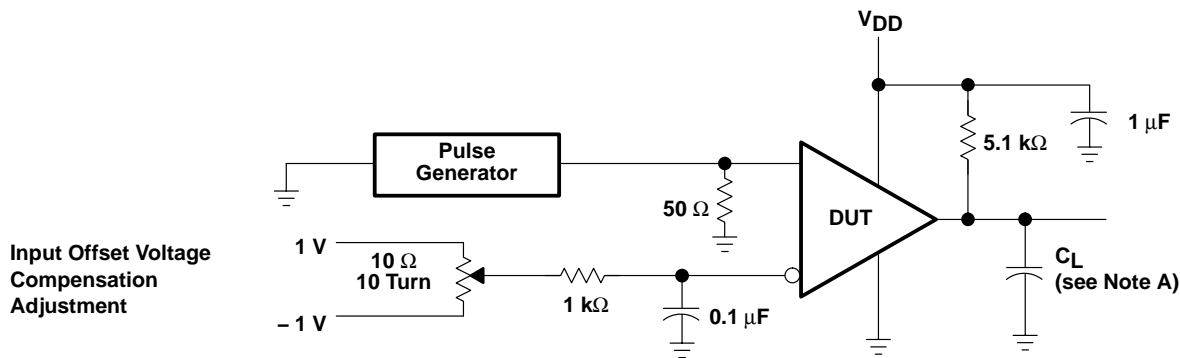

Figure 2. Circuit for Input Offset Voltage Measurement



PARAMETER MEASUREMENT INFORMATION

Propagation delay time is defined as the interval between the application of an input step function and the instant when the output reaches 50% of its maximum value. Propagation delay time, low-to-high-level output, is measured from the leading edge of the input pulse, while propagation delay time, high-to-low-level output, is measured from the trailing edge of the input pulse. Propagation delay time measurement at low input signal levels can be greatly affected by the input offset voltage. The offset voltage should be balanced by the adjustment at the inverting input (as shown in Figure 3) so that the circuit is just at the transition point. Then a low signal, for example, 105 mV or 5 mV overdrive, causes the output to change state.



TEST CIRCUIT

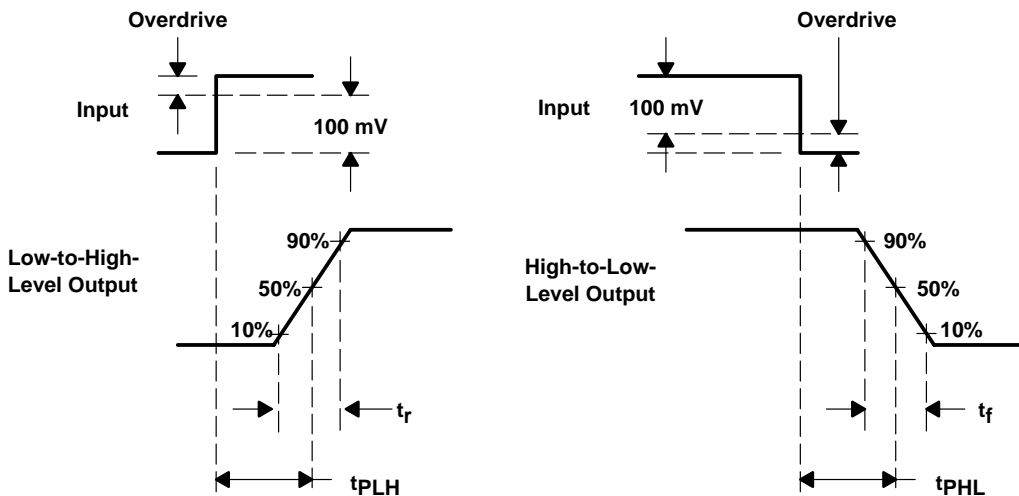

VOLTAGE WAVEFORMS

NOTE A: C_L includes probe and jig capacitance.

Figure 3. Propagation Delay, Rise Time, and Fall Time Circuit and Voltage Waveforms

TLC193, TLC393 DUAL MICROWPOWER LinCMOS™ VOLTAGE COMPARATOR

SLCS115D – DECEMBER 1986 – REVISED JULY 2003

TYPICAL CHARACTERISTICS

Table of Graphs

			FIGURE
V_{IO}	Input offset voltage	Distribution	4
I_{IB}	Input bias current	vs Free-air temperature	5
CMRR	Common-mode rejection ratio	vs Free-air temperature	6
k_{SVR}	Supply-voltage rejection ratio	vs Free-air temperature	7
V_{OL}	Low-level output voltage	vs Low-level output current	8
		vs Free-air temperature	9
I_{OH}	Low-level output current	vs High-level output voltage	10
		vs Free-air temperature	11
I_{DD}	Supply current	vs Supply voltage	12
		vs Free-air temperature	13
t_{PLH}	Low-to-high level output propagation delay time	vs Supply voltage	14
t_{PHL}	High-to-low level output propagation delay time	vs Supply voltage	15
	Low-to-high-level output response	Low-to-high level output propagation delay time	16
	High-to-low level output response	High-to-low level output propagation delay time	17
t_f	Fall time	vs Supply voltage	18

DISTRIBUTION OF INPUT
OFFSET VOLTAGE†

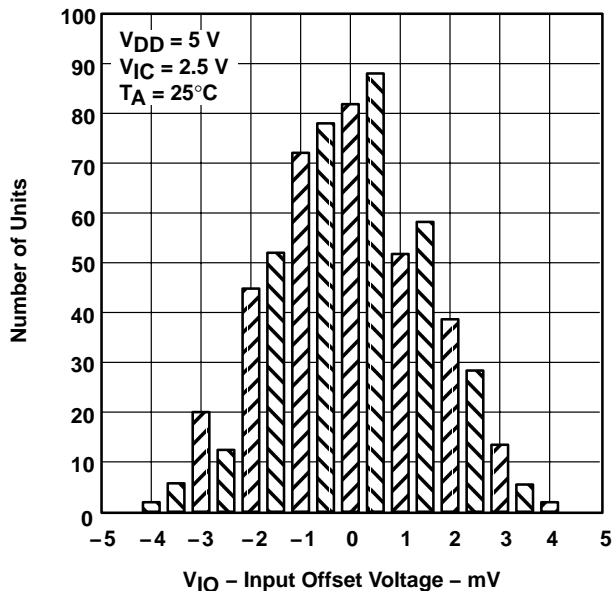

Figure 4

INPUT BIAS CURRENT
VS
FREE-AIR TEMPERATURE†

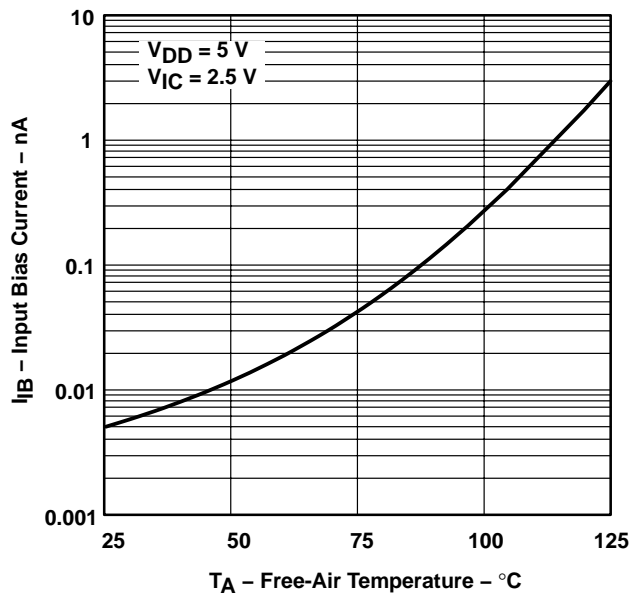

Figure 5

† Data at high and low temperatures are applicable only within the rated operating free-air temperature ranges of the various devices.

TYPICAL CHARACTERISTICS†

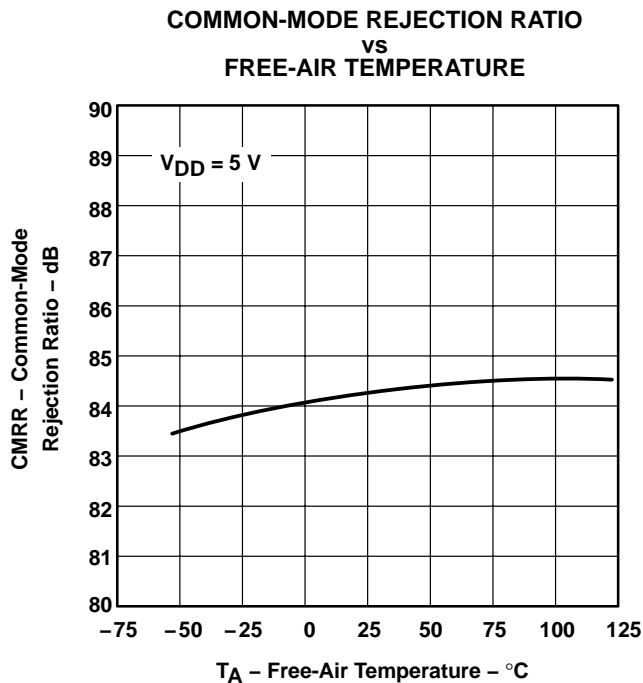

Figure 6

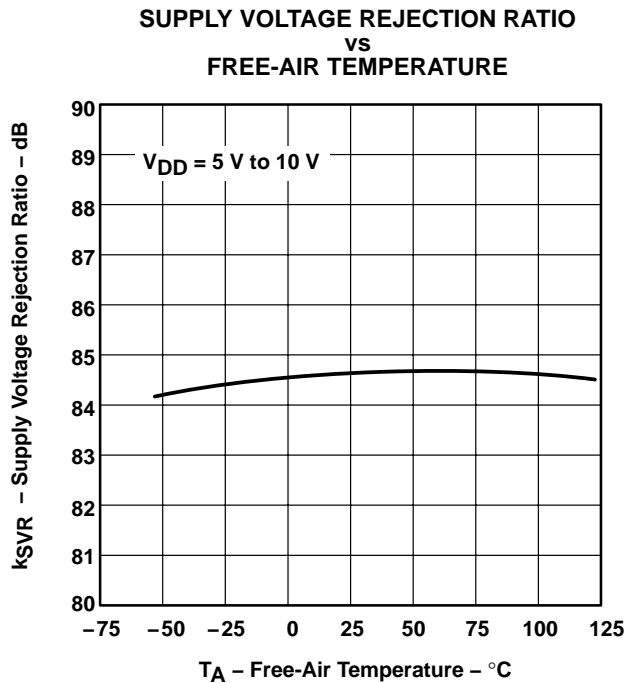

Figure 7

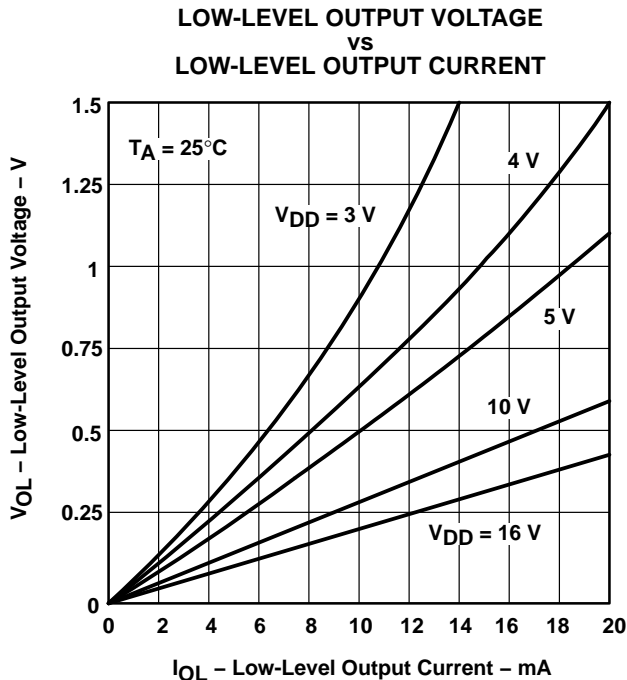

Figure 8

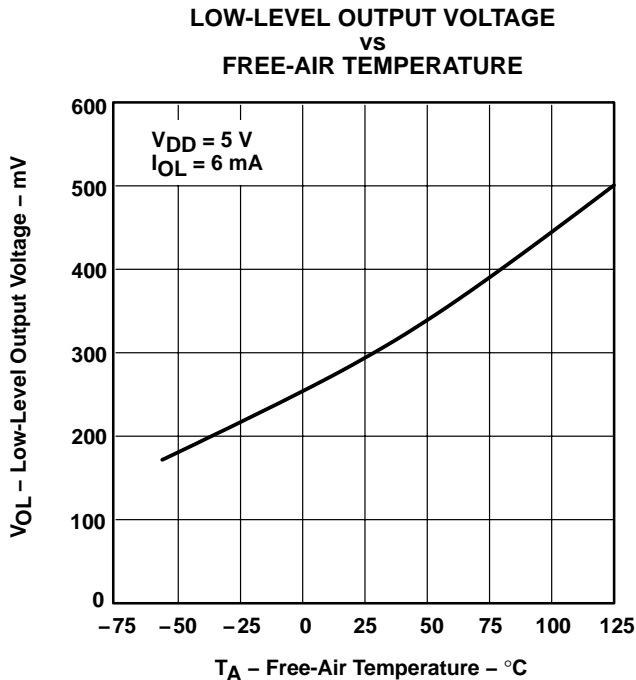

Figure 9

† Data at high and low temperatures are applicable only within the rated operating free-air temperature ranges of the various devices.

TLC193, TLC393 DUAL MICROWPOWER LinCMOS™ VOLTAGE COMPARATOR

SLCS115D – DECEMBER 1986 – REVISED JULY 2003

TYPICAL CHARACTERISTICS†

HIGH-LEVEL OUTPUT CURRENT
vs
HIGH-LEVEL OUTPUT VOLTAGE

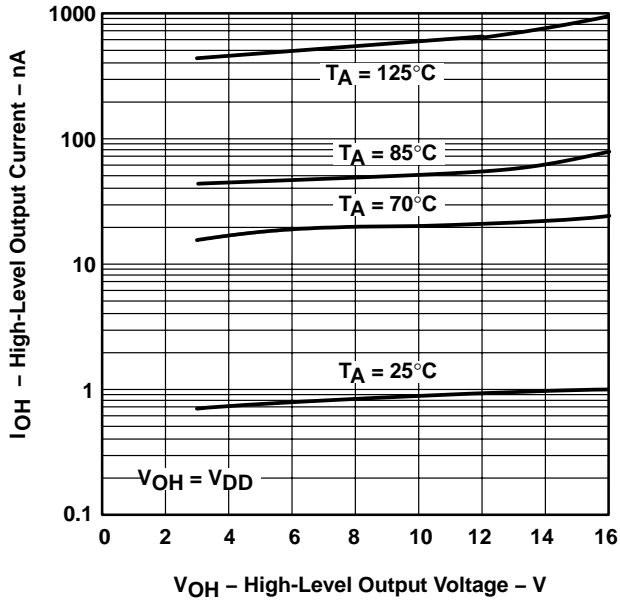

Figure 10

HIGH-LEVEL OUTPUT CURRENT
vs
FREE-AIR TEMPERATURE

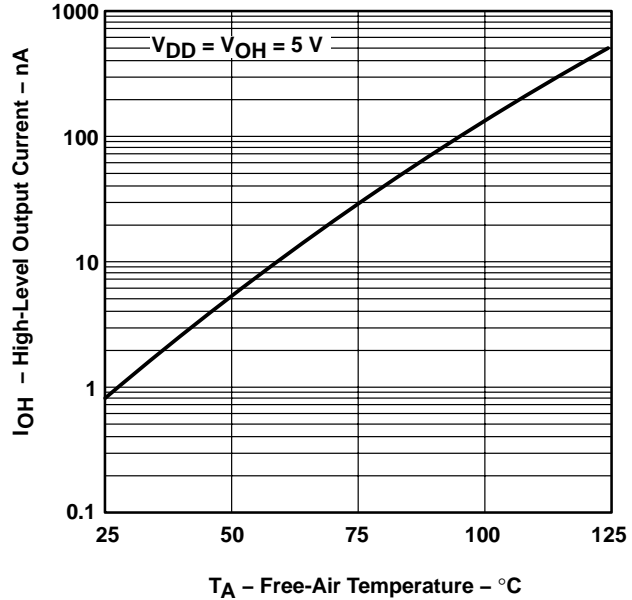

Figure 11

SUPPLY CURRENT
vs
SUPPLY VOLTAGE

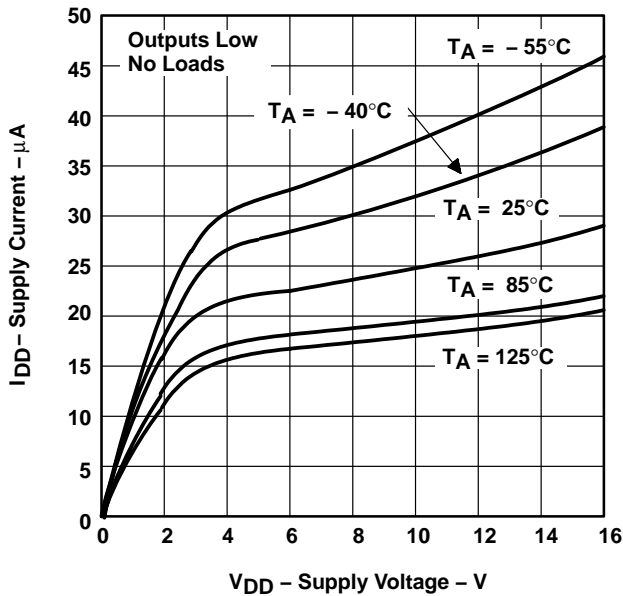

Figure 12

SUPPLY CURRENT
vs
FREE-AIR TEMPERATURE

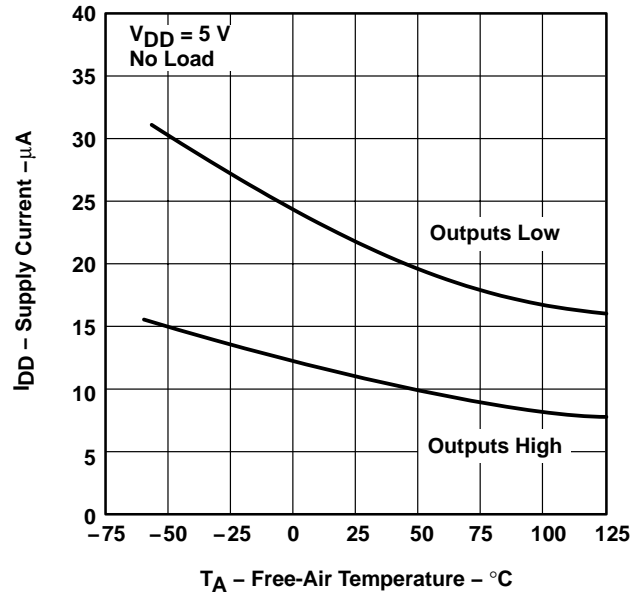
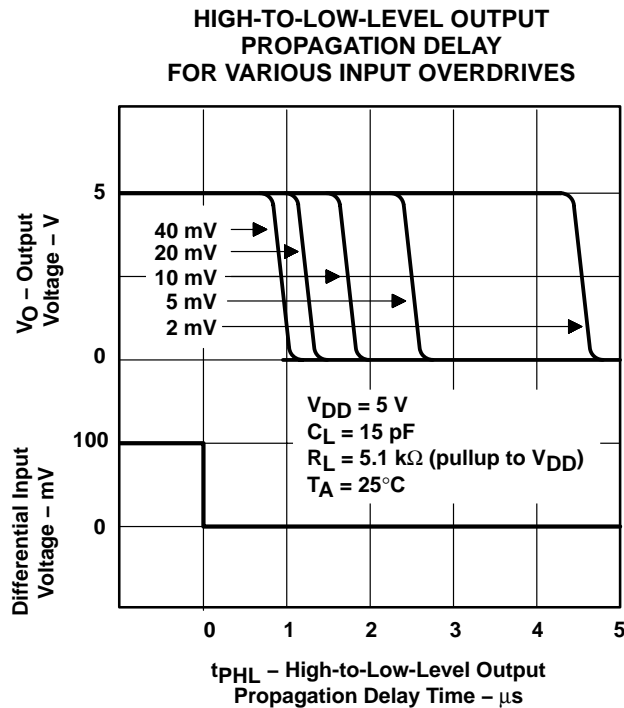
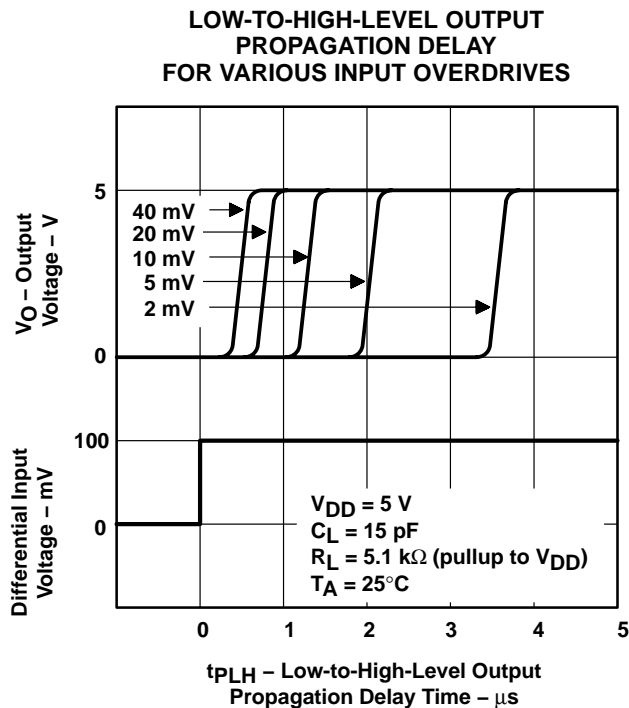
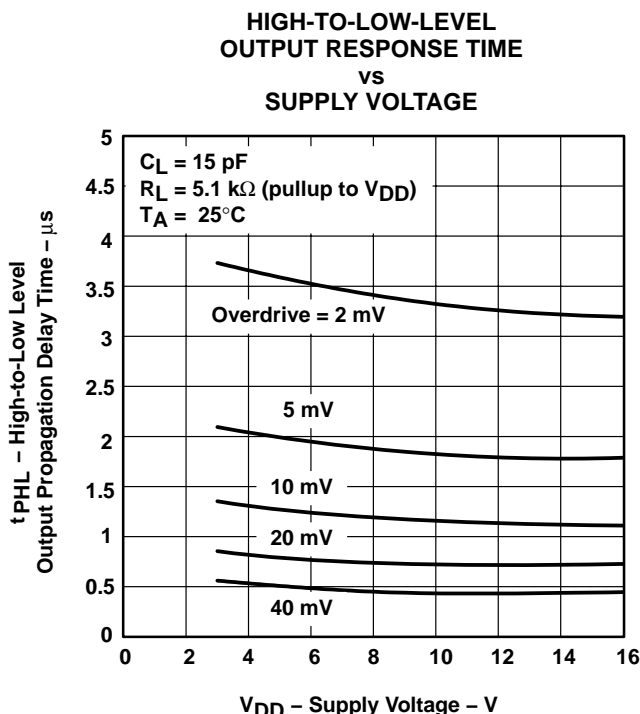
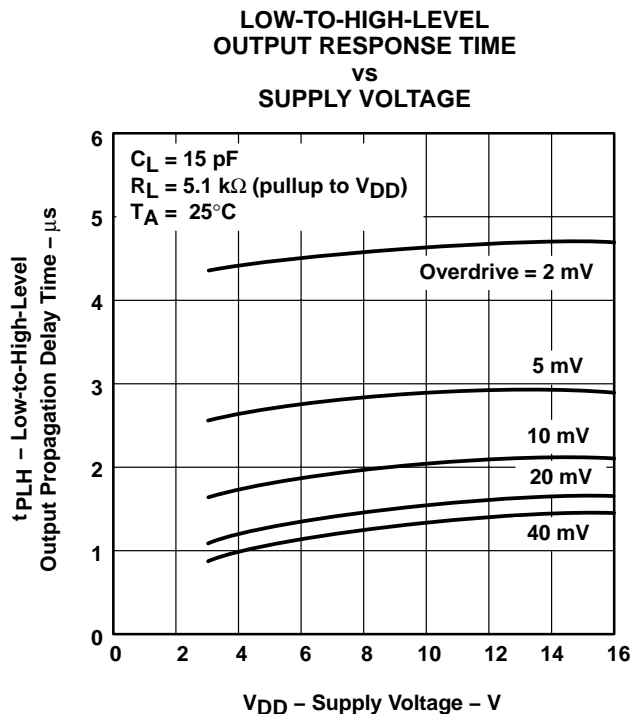

Figure 13

† Data at high and low temperatures are applicable only within the rated operating free-air temperature ranges of the various devices.



TYPICAL CHARACTERISTICS



TLC193, TLC393 DUAL MICROWPOWER LinCMOS™ VOLTAGE COMPARATOR

SLCS115D – DECEMBER 1986 – REVISED JULY 2003

TYPICAL CHARACTERISTICS

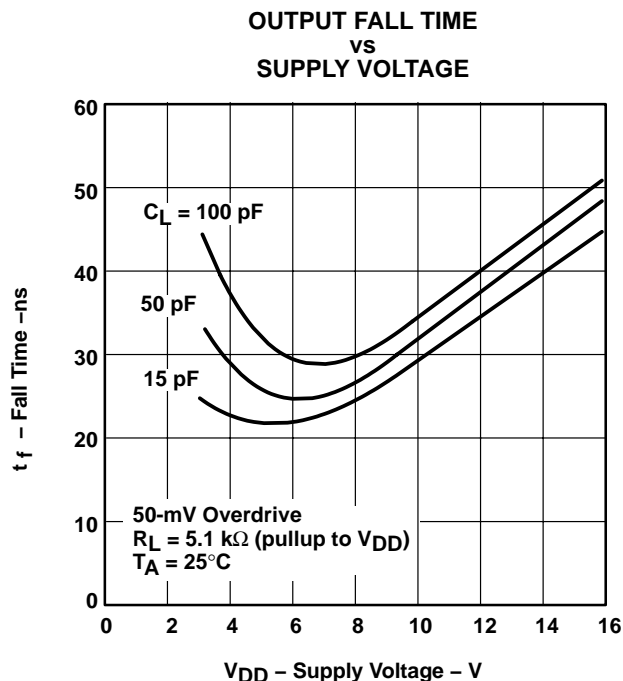

APPLICATION INFORMATION

The input should always remain within the supply rails in order to avoid forward biasing the diodes in the electrostatic discharge (ESD) protection structure. If either input exceeds this range, the device will not be damaged as long as the input current is limited to less than 5 mA. To maintain the expected output state, the inputs must remain within the common-mode range. For example, at 25°C with $V_{DD} = 5$ V, both inputs must remain between -0.2 V and 4 V to assure proper device operation.

To assure reliable operation, the supply should be decoupled with a capacitor (0.1- μ F) positioned as close to the device as possible.

The TLC393 has internal ESD-protection circuits that prevent functional failures at voltages up to 2000 V as tested under MIL-STD-883C, Method 3015.2; however, care should be exercised in handling these devices, as exposure to ESD may result in the degradation of the device parametric performance.

Table of Applications

	FIGURE
Pulse-width-modulated motor speed controller	19
Enhanced supply supervisor	20
Two-phase nonoverlapping clock generator	21
Micropower switching regulator	28



APPLICATION INFORMATION

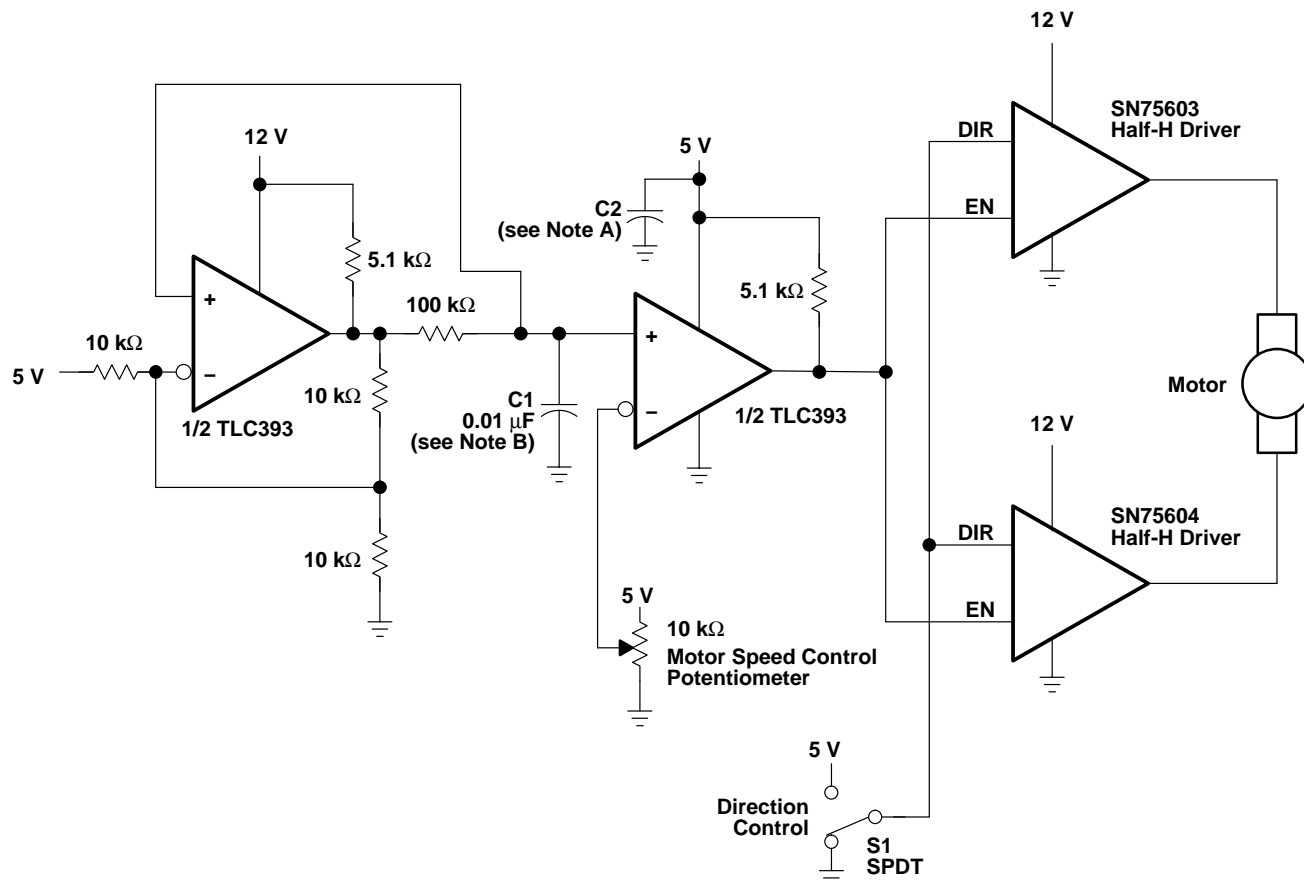

NOTES: A. The recommended minimum capacitance is 10 μF to eliminate common ground switching noise.
 B. Adjust C1 for change in oscillator frequency.

Figure 19. Pulse-Width-Modulated Motor Speed Controller

TLC193, TLC393 DUAL MICROPPOWER LinCMOS™ VOLTAGE COMPARATOR

SLCS115D – DECEMBER 1986 – REVISED JULY 2003

APPLICATION INFORMATION

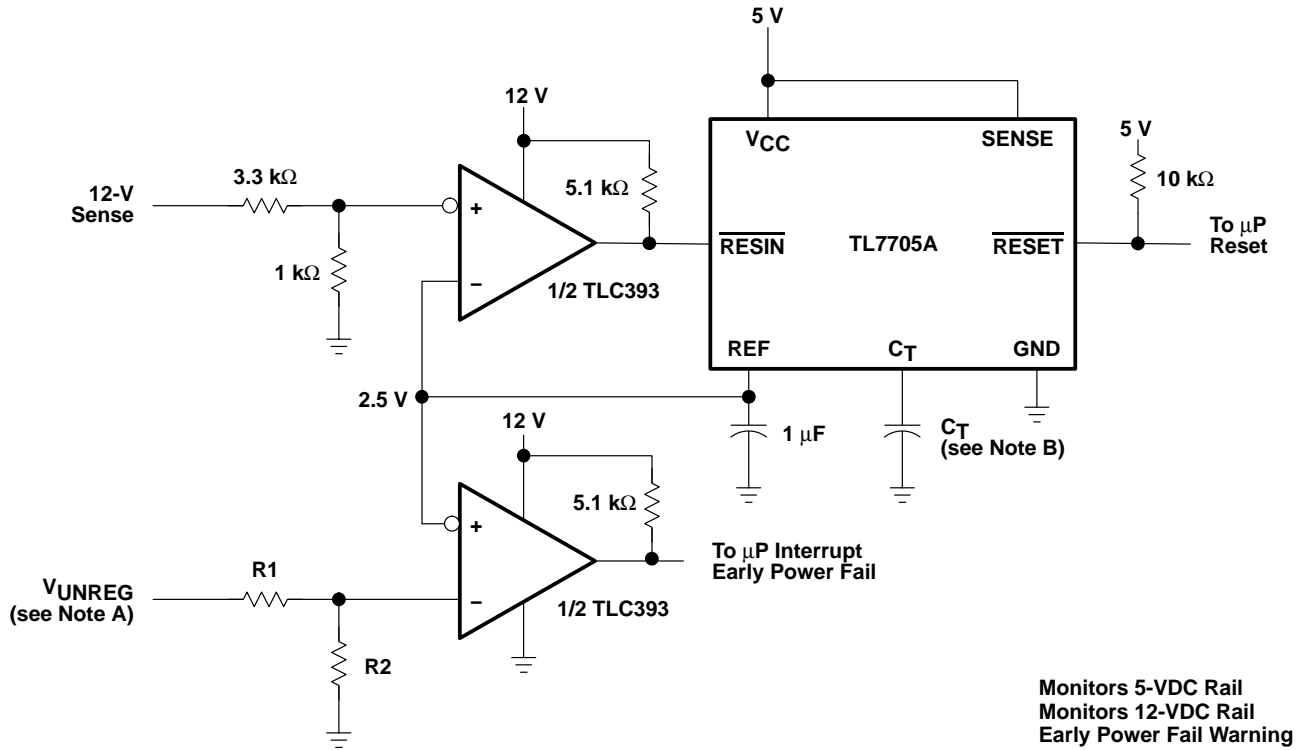

- NOTES: A. $V_{UNREG} = 2.5 \frac{(R1 + R2)}{R2}$
 B. The value of C_T determines the time delay of reset.

Figure 20. Enhanced Supply Supervisor



APPLICATION INFORMATION

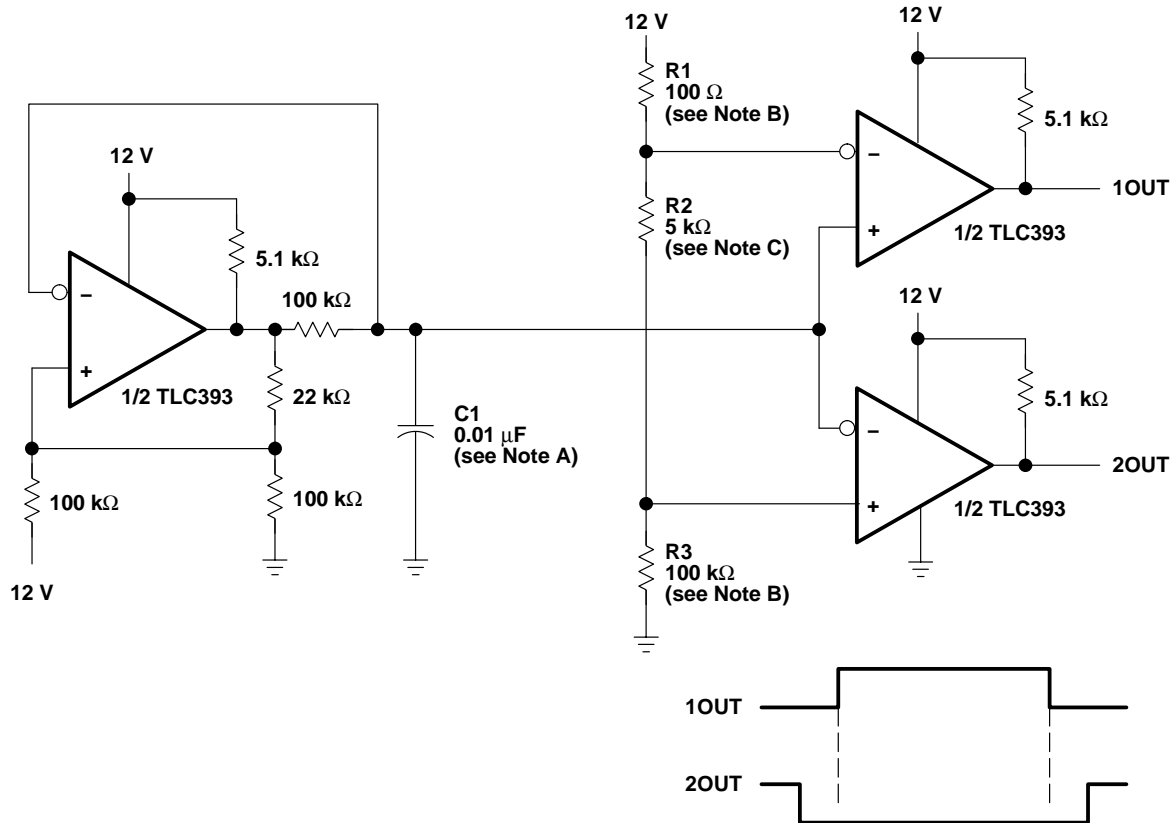

- NOTES: A. Adjust C1 for a change in oscillator frequency where:
 $1/f = 1.85(100\text{ k}\Omega)C1$
 B. Adjust R1 and R3 to change duty cycle
 C. Adjust R2 to change deadtime

Figure 21. Two-Phase Nonoverlapping Clock Generator

PACKAGING INFORMATION

Orderable Device	Status (1)	Package Type	Package Drawing	Pins	Package Qty	Eco Plan (2)	Lead finish/ Ball material (6)	MSL Peak Temp (3)	Op Temp (°C)	Device Marking (4/5)	Samples
5962-9555101NXD	ACTIVE	SOIC	D	8	2500	RoHS & Green	NIPDAU	Level-1-260C-UNLIM		Q193M	Samples
5962-9555101NXDR	ACTIVE	SOIC	D	8	2500	RoHS & Green	NIPDAU	Level-1-260C-UNLIM		Q193M	Samples
5962-9555101QPA	ACTIVE	CDIP	JG	8	1	Non-RoHS & Green	SNPB	N / A for Pkg Type	-55 to 125	9555101QPA TLC193M	Samples
TLC193MJGB	ACTIVE	CDIP	JG	8	1	Non-RoHS & Green	SNPB	N / A for Pkg Type		9555101QPA TLC193M	Samples
TLC393CD	ACTIVE	SOIC	D	8	75	RoHS & Green	NIPDAU	Level-1-260C-UNLIM	0 to 70	C393C	Samples
TLC393CDR	ACTIVE	SOIC	D	8	2500	RoHS & Green	NIPDAU	Level-1-260C-UNLIM	0 to 70	C393C	Samples
TLC393CP	ACTIVE	PDIP	P	8	50	RoHS & Green	NIPDAU	N / A for Pkg Type	0 to 70	TLC393CP	Samples
TLC393CPS	ACTIVE	SO	PS	8	80	RoHS & Green	NIPDAU	Level-1-260C-UNLIM	0 to 70	P393	Samples
TLC393CPSR	ACTIVE	SO	PS	8	2000	RoHS & Green	NIPDAU	Level-1-260C-UNLIM	0 to 70	P393	Samples
TLC393CPW	ACTIVE	TSSOP	PW	8	150	RoHS & Green	NIPDAU	Level-1-260C-UNLIM	0 to 70	P393	Samples
TLC393CPWR	ACTIVE	TSSOP	PW	8	2000	RoHS & Green	NIPDAU	Level-1-260C-UNLIM	0 to 70	P393	Samples
TLC393CPWRG4	ACTIVE	TSSOP	PW	8	2000	RoHS & Green	NIPDAU	Level-1-260C-UNLIM	0 to 70	P393	Samples
TLC393ID	ACTIVE	SOIC	D	8	75	RoHS & Green	NIPDAU	Level-1-260C-UNLIM	-40 to 85	C393I	Samples
TLC393IDG4	ACTIVE	SOIC	D	8	75	RoHS & Green	NIPDAU	Level-1-260C-UNLIM	-40 to 85	C393I	Samples
TLC393IDR	ACTIVE	SOIC	D	8	2500	RoHS & Green	NIPDAU	Level-1-260C-UNLIM	-40 to 85	C393I	Samples
TLC393IDRG4	ACTIVE	SOIC	D	8	2500	RoHS & Green	NIPDAU	Level-1-260C-UNLIM	-40 to 85	C393I	Samples
TLC393IP	ACTIVE	PDIP	P	8	50	RoHS & Green	NIPDAU	N / A for Pkg Type	-40 to 85	TLC393IP	Samples
TLC393IPE4	ACTIVE	PDIP	P	8	50	RoHS & Green	NIPDAU	N / A for Pkg Type	-40 to 85	TLC393IP	Samples
TLC393IPW	ACTIVE	TSSOP	PW	8	150	RoHS & Green	NIPDAU	Level-1-260C-UNLIM	-40 to 85	Y393	Samples

Orderable Device	Status (1)	Package Type	Package Drawing	Pins	Package Qty	Eco Plan (2)	Lead finish/ Ball material (6)	MSL Peak Temp (3)	Op Temp (°C)	Device Marking (4/5)	Samples
TLC393IPWG4	ACTIVE	TSSOP	PW	8	150	RoHS & Green	NIPDAU	Level-1-260C-UNLIM	-40 to 85	Y393	Samples
TLC393IPWR	ACTIVE	TSSOP	PW	8	2000	RoHS & Green	NIPDAU	Level-1-260C-UNLIM	-40 to 85	Y393	Samples
TLC393IPWRG4	ACTIVE	TSSOP	PW	8	2000	RoHS & Green	NIPDAU	Level-1-260C-UNLIM	-40 to 85	Y393	Samples
TLC393QDR	ACTIVE	SOIC	D	8	2500	RoHS & Green	NIPDAU	Level-1-260C-UNLIM	-40 to 125	C393Q	Samples
TLC393QDRG4	ACTIVE	SOIC	D	8	2500	RoHS & Green	NIPDAU	Level-1-260C-UNLIM		C393Q	Samples

(1) The marketing status values are defined as follows:

ACTIVE: Product device recommended for new designs.

LIFEBUY: TI has announced that the device will be discontinued, and a lifetime-buy period is in effect.

NRND: Not recommended for new designs. Device is in production to support existing customers, but TI does not recommend using this part in a new design.

PREVIEW: Device has been announced but is not in production. Samples may or may not be available.

OBSOLETE: TI has discontinued the production of the device.

(2) **RoHS:** TI defines "RoHS" to mean semiconductor products that are compliant with the current EU RoHS requirements for all 10 RoHS substances, including the requirement that RoHS substance do not exceed 0.1% by weight in homogeneous materials. Where designed to be soldered at high temperatures, "RoHS" products are suitable for use in specified lead-free processes. TI may reference these types of products as "Pb-Free".

RoHS Exempt: TI defines "RoHS Exempt" to mean products that contain lead but are compliant with EU RoHS pursuant to a specific EU RoHS exemption.

Green: TI defines "Green" to mean the content of Chlorine (Cl) and Bromine (Br) based flame retardants meet JS709B low halogen requirements of <=1000ppm threshold. Antimony trioxide based flame retardants must also meet the <=1000ppm threshold requirement.

(3) MSL, Peak Temp. - The Moisture Sensitivity Level rating according to the JEDEC industry standard classifications, and peak solder temperature.

(4) There may be additional marking, which relates to the logo, the lot trace code information, or the environmental category on the device.

(5) Multiple Device Markings will be inside parentheses. Only one Device Marking contained in parentheses and separated by a "~" will appear on a device. If a line is indented then it is a continuation of the previous line and the two combined represent the entire Device Marking for that device.

(6) Lead finish/Ball material - Orderable Devices may have multiple material finish options. Finish options are separated by a vertical ruled line. Lead finish/Ball material values may wrap to two lines if the finish value exceeds the maximum column width.

Important Information and Disclaimer:The information provided on this page represents TI's knowledge and belief as of the date that it is provided. TI bases its knowledge and belief on information provided by third parties, and makes no representation or warranty as to the accuracy of such information. Efforts are underway to better integrate information from third parties. TI has taken and

continues to take reasonable steps to provide representative and accurate information but may not have conducted destructive testing or chemical analysis on incoming materials and chemicals. TI and TI suppliers consider certain information to be proprietary, and thus CAS numbers and other limited information may not be available for release.

In no event shall TI's liability arising out of such information exceed the total purchase price of the TI part(s) at issue in this document sold by TI to Customer on an annual basis.

OTHER QUALIFIED VERSIONS OF TLC393 :

- Automotive : [TLC393-Q1](#)

NOTE: Qualified Version Definitions:

- Automotive - Q100 devices qualified for high-reliability automotive applications targeting zero defects

TAPE AND REEL INFORMATION

QUADRANT ASSIGNMENTS FOR PIN 1 ORIENTATION IN TAPE



*All dimensions are nominal

Device	Package Type	Package Drawing	Pins	SPQ	Reel Diameter (mm)	Reel Width W1 (mm)	A0 (mm)	B0 (mm)	K0 (mm)	P1 (mm)	W (mm)	Pin1 Quadrant
5962-9555101NXDR	SOIC	D	8	2500	330.0	12.4	6.4	5.2	2.1	8.0	12.0	Q1
TLC393CDR	SOIC	D	8	2500	330.0	12.4	6.4	5.2	2.1	8.0	12.0	Q1
TLC393CPSR	SO	PS	8	2000	330.0	16.4	8.35	6.6	2.5	12.0	16.0	Q1
TLC393CPWR	TSSOP	PW	8	2000	330.0	12.4	7.0	3.6	1.6	8.0	12.0	Q1
TLC393IDR	SOIC	D	8	2500	330.0	12.4	6.4	5.2	2.1	8.0	12.0	Q1
TLC393IPWR	TSSOP	PW	8	2000	330.0	12.4	7.0	3.6	1.6	8.0	12.0	Q1
TLC393QDR	SOIC	D	8	2500	330.0	12.4	6.4	5.2	2.1	8.0	12.0	Q1
TLC393QDRG4	SOIC	D	8	2500	330.0	12.4	6.4	5.2	2.1	8.0	12.0	Q1

TAPE AND REEL BOX DIMENSIONS

*All dimensions are nominal

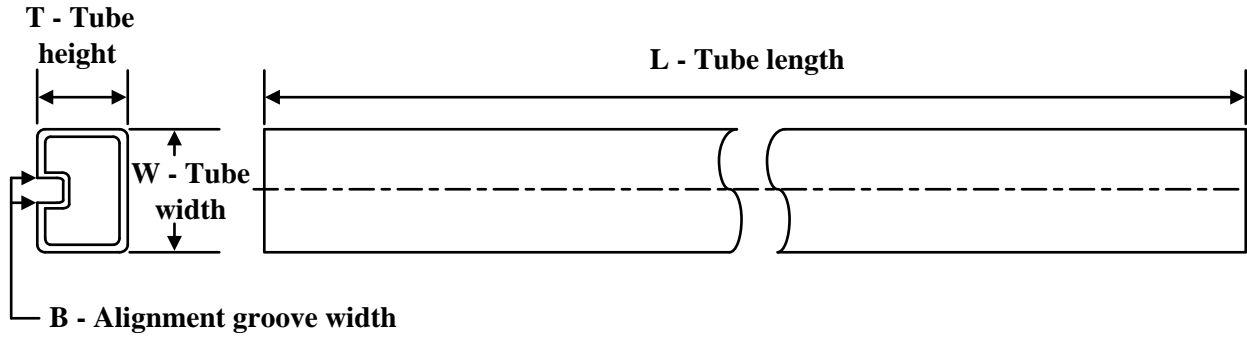
Device	Package Type	Package Drawing	Pins	SPQ	Length (mm)	Width (mm)	Height (mm)
5962-9555101NXDR	SOIC	D	8	2500	350.0	350.0	43.0
TLC393CDR	SOIC	D	8	2500	340.5	336.1	25.0
TLC393CPSR	SO	PS	8	2000	356.0	356.0	35.0
TLC393CPWR	TSSOP	PW	8	2000	356.0	356.0	35.0
TLC393IDR	SOIC	D	8	2500	340.5	336.1	25.0
TLC393IPWR	TSSOP	PW	8	2000	356.0	356.0	35.0
TLC393QDR	SOIC	D	8	2500	350.0	350.0	43.0
TLC393QDRG4	SOIC	D	8	2500	350.0	350.0	43.0

TUBE

*All dimensions are nominal

Device	Package Name	Package Type	Pins	SPQ	L (mm)	W (mm)	T (μm)	B (mm)
TLC393CD	D	SOIC	8	75	507	8	3940	4.32
TLC393CP	P	PDIP	8	50	506	13.97	11230	4.32
TLC393CPS	PS	SOP	8	80	530	10.5	4000	4.1
TLC393CPW	PW	TSSOP	8	150	530	10.2	3600	3.5
TLC393ID	D	SOIC	8	75	507	8	3940	4.32
TLC393ID	D	SOIC	8	75	505.46	6.76	3810	4
TLC393IDG4	D	SOIC	8	75	505.46	6.76	3810	4
TLC393IDG4	D	SOIC	8	75	507	8	3940	4.32
TLC393IP	P	PDIP	8	50	506	13.97	11230	4.32
TLC393IPE4	P	PDIP	8	50	506	13.97	11230	4.32
TLC393IPW	PW	TSSOP	8	150	530	10.2	3600	3.5
TLC393IPWG4	PW	TSSOP	8	150	530	10.2	3600	3.5



D0008A

PACKAGE OUTLINE

SOIC - 1.75 mm max height

SMALL OUTLINE INTEGRATED CIRCUIT



4214825/C 02/2019

NOTES:

- Linear dimensions are in inches [millimeters]. Dimensions in parenthesis are for reference only. Controlling dimensions are in inches. Dimensioning and tolerancing per ASME Y14.5M.
- This drawing is subject to change without notice.
- This dimension does not include mold flash, protrusions, or gate burrs. Mold flash, protrusions, or gate burrs shall not exceed $.006$ [0.15] per side.
- This dimension does not include interlead flash.
- Reference JEDEC registration MS-012, variation AA.

EXAMPLE BOARD LAYOUT

D0008A

SOIC - 1.75 mm max height

SMALL OUTLINE INTEGRATED CIRCUIT



LAND PATTERN EXAMPLE
 EXPOSED METAL SHOWN
 SCALE:8X

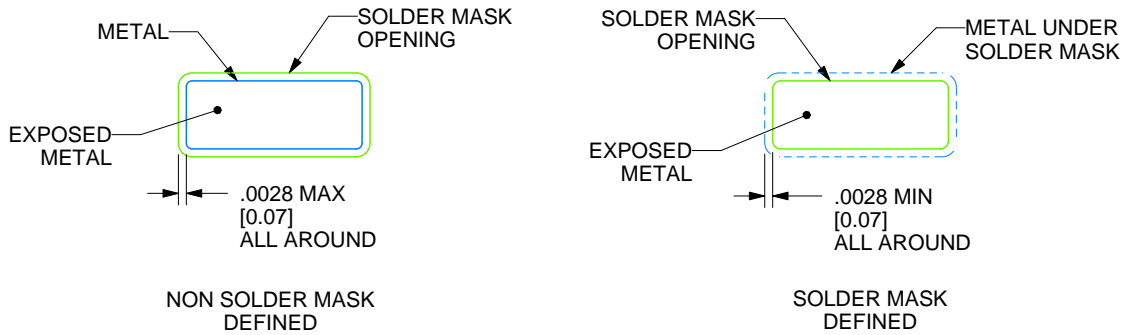

SOLDER MASK DETAILS

4214825/C 02/2019

NOTES: (continued)

- 6. Publication IPC-7351 may have alternate designs.
- 7. Solder mask tolerances between and around signal pads can vary based on board fabrication site.

EXAMPLE STENCIL DESIGN

D0008A

SOIC - 1.75 mm max height

SMALL OUTLINE INTEGRATED CIRCUIT



SOLDER PASTE EXAMPLE
BASED ON .005 INCH [0.125 MM] THICK STENCIL
SCALE:8X

4214825/C 02/2019

NOTES: (continued)

8. Laser cutting apertures with trapezoidal walls and rounded corners may offer better paste release. IPC-7525 may have alternate design recommendations.
9. Board assembly site may have different recommendations for stencil design.

MECHANICAL DATA

PS (R-PDSO-G8)

PLASTIC SMALL-OUTLINE PACKAGE

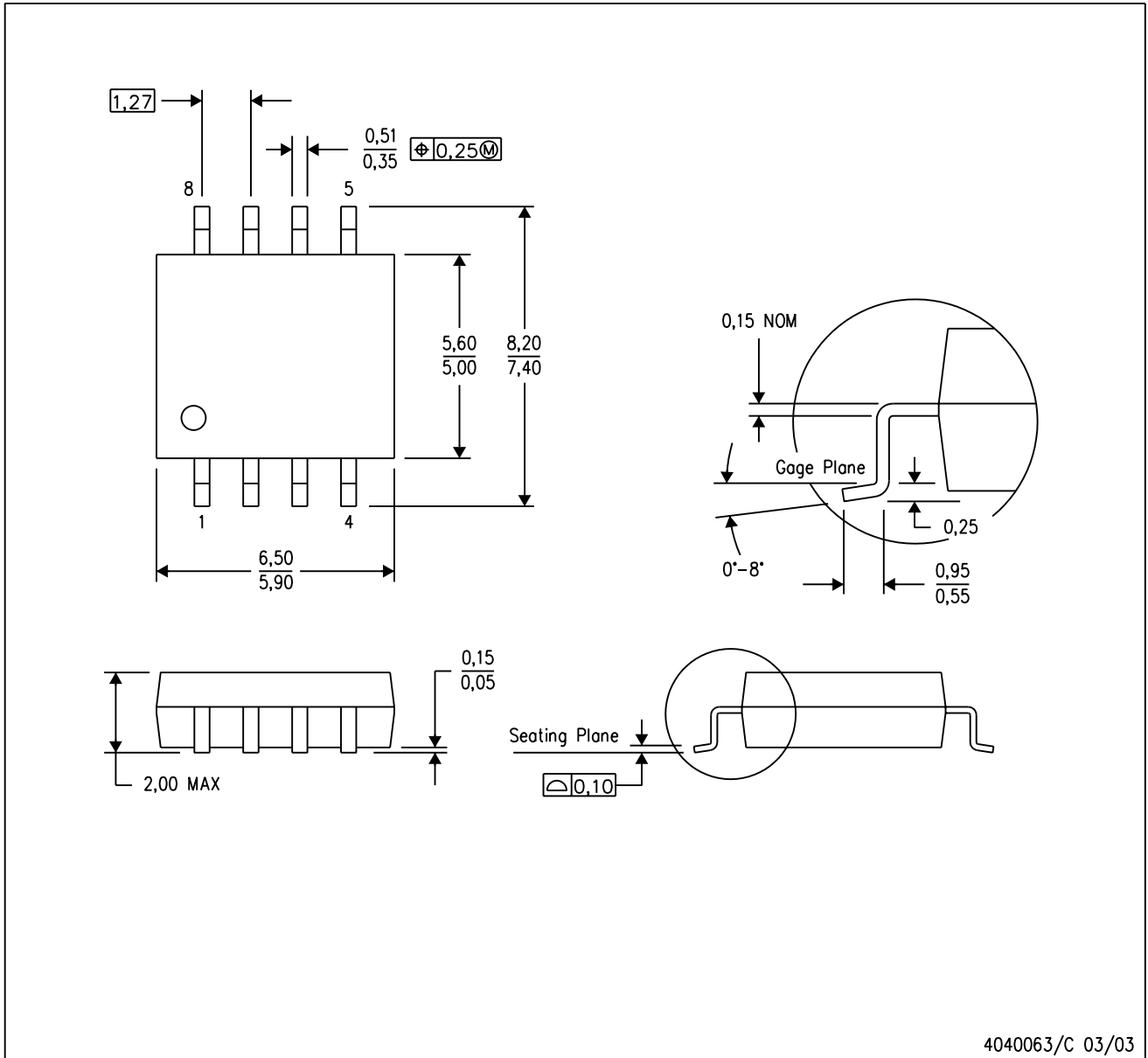

- NOTES:
- A. All linear dimensions are in millimeters.
 - B. This drawing is subject to change without notice.
 - C. Body dimensions do not include mold flash or protrusion, not to exceed 0,15.

PS (R-PDSO-G8)

PLASTIC SMALL OUTLINE

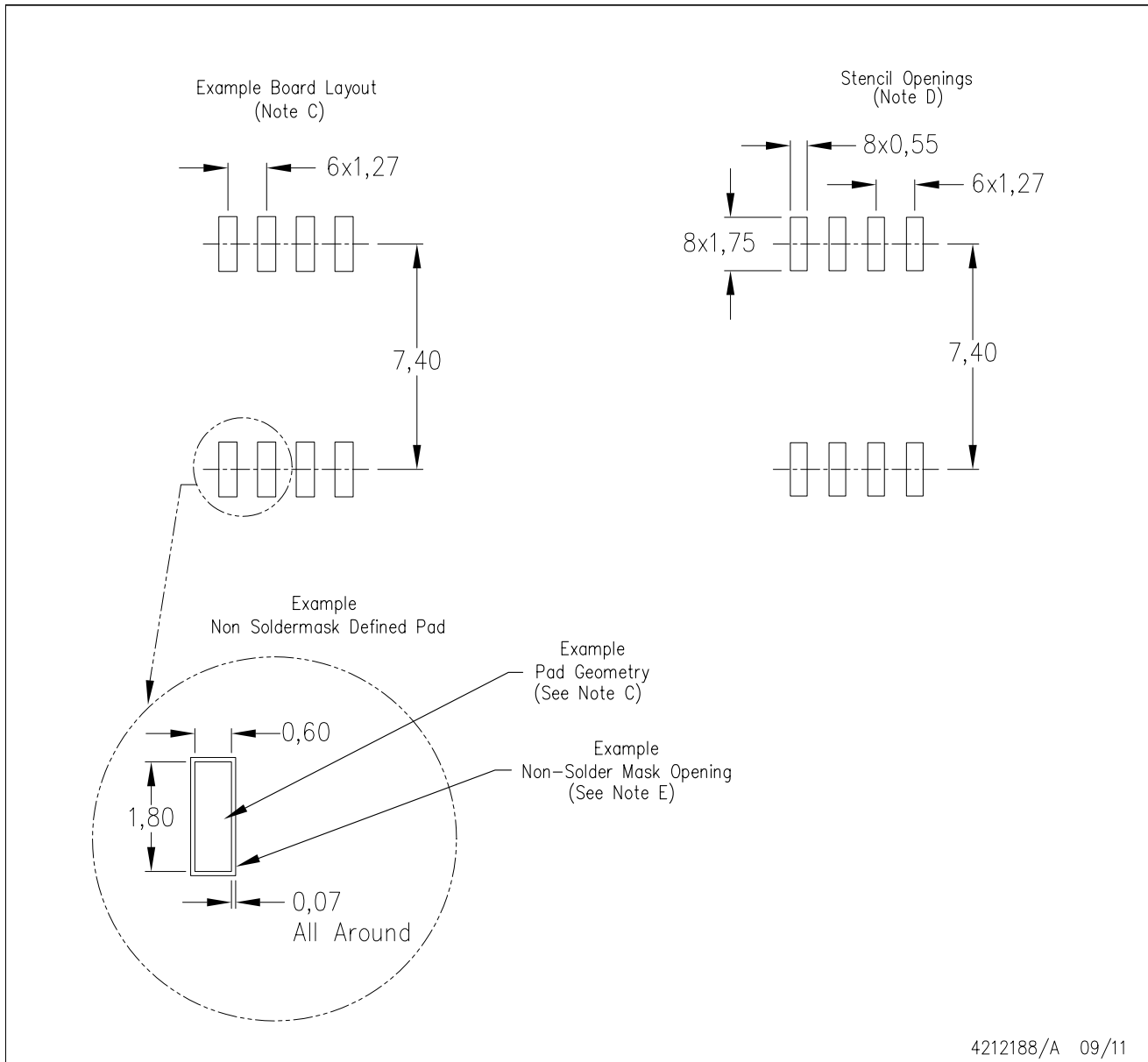

- NOTES:
- All linear dimensions are in millimeters.
 - This drawing is subject to change without notice.
 - Publication IPC-7351 is recommended for alternate designs.
 - Laser cutting apertures with trapezoidal walls and also rounding corners will offer better paste release. Customers should contact their board assembly site for stencil design recommendations. Refer to IPC-7525 for other stencil recommendations.
 - Customers should contact their board fabrication site for solder mask tolerances between and around signal pads.

JG (R-GDIP-T8)

CERAMIC DUAL-IN-LINE



- NOTES: A. All linear dimensions are in inches (millimeters).
 B. This drawing is subject to change without notice.
 C. This package can be hermetically sealed with a ceramic lid using glass frit.
 D. Index point is provided on cap for terminal identification.
 E. Falls within MIL STD 1835 GDIP1-T8

P (R-PDIP-T8)

PLASTIC DUAL-IN-LINE PACKAGE



- NOTES:
- A. All linear dimensions are in inches (millimeters).
 - B. This drawing is subject to change without notice.
 - C. Falls within JEDEC MS-001 variation BA.

PW0008A



PACKAGE OUTLINE
TSSOP - 1.2 mm max height

SMALL OUTLINE PACKAGE

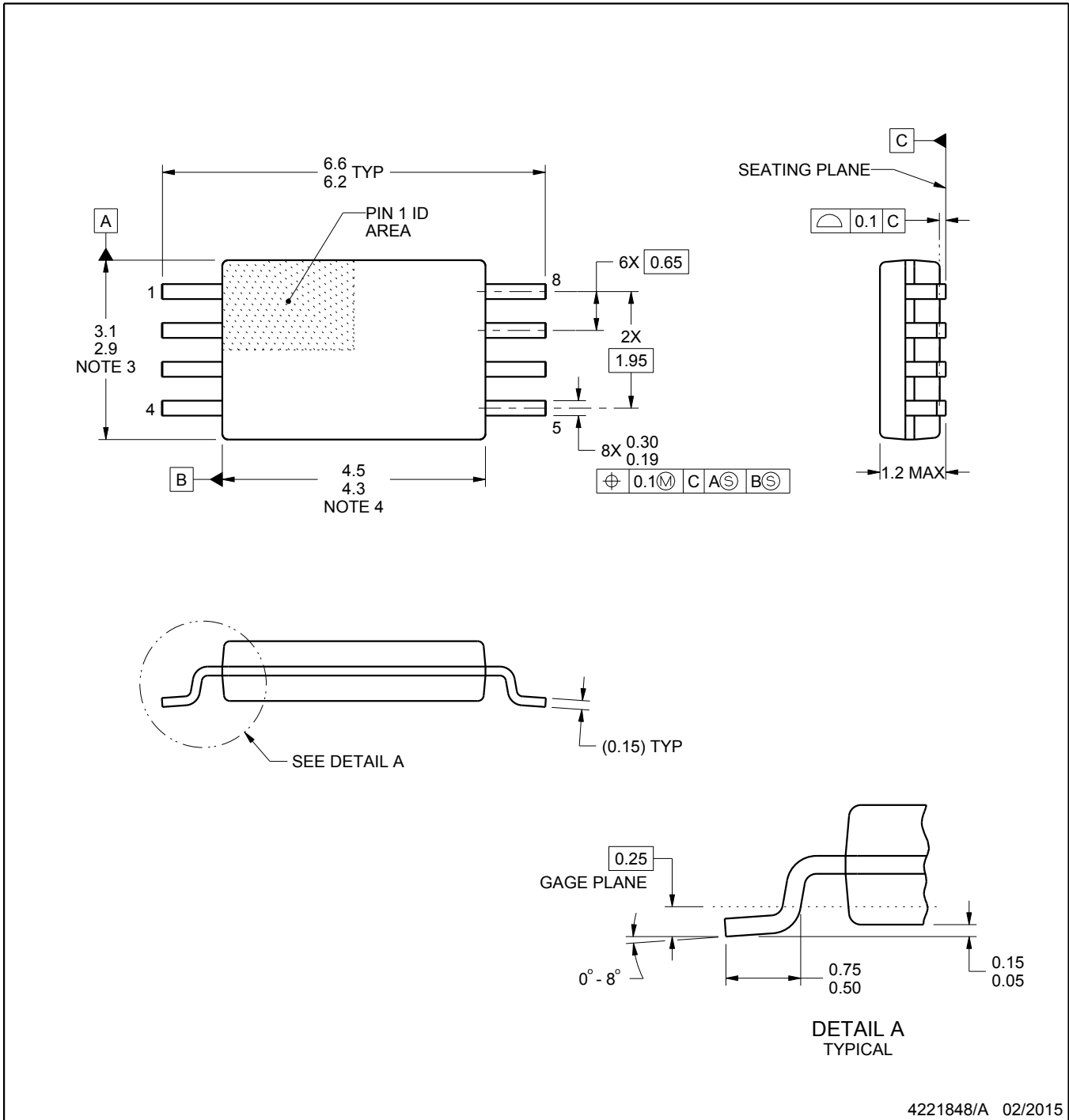

4221848/A 02/2015

NOTES:

1. All linear dimensions are in millimeters. Any dimensions in parenthesis are for reference only. Dimensioning and tolerancing per ASME Y14.5M.
2. This drawing is subject to change without notice.
3. This dimension does not include mold flash, protrusions, or gate burrs. Mold flash, protrusions, or gate burrs shall not exceed 0.15 mm per side.
4. This dimension does not include interlead flash. Interlead flash shall not exceed 0.25 mm per side.
5. Reference JEDEC registration MO-153, variation AA.

EXAMPLE BOARD LAYOUT

PW0008A

TSSOP - 1.2 mm max height

SMALL OUTLINE PACKAGE

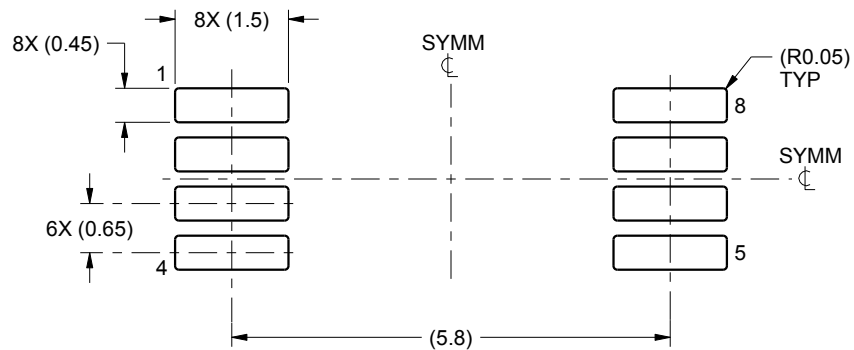

LAND PATTERN EXAMPLE
SCALE:10X

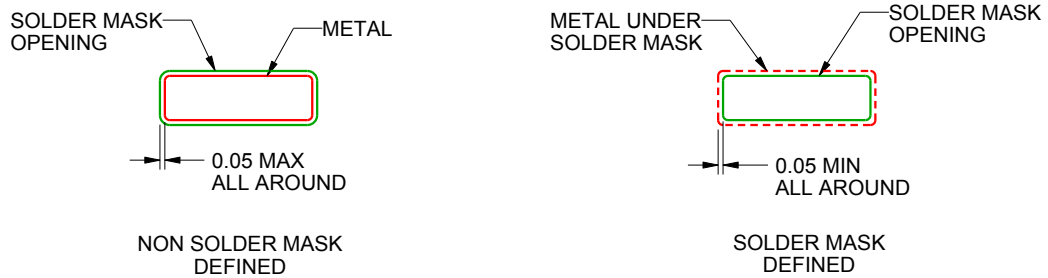

SOLDER MASK DETAILS
NOT TO SCALE

4221848/A 02/2015

NOTES: (continued)

- 6. Publication IPC-7351 may have alternate designs.
- 7. Solder mask tolerances between and around signal pads can vary based on board fabrication site.

EXAMPLE STENCIL DESIGN

PW0008A

TSSOP - 1.2 mm max height

SMALL OUTLINE PACKAGE

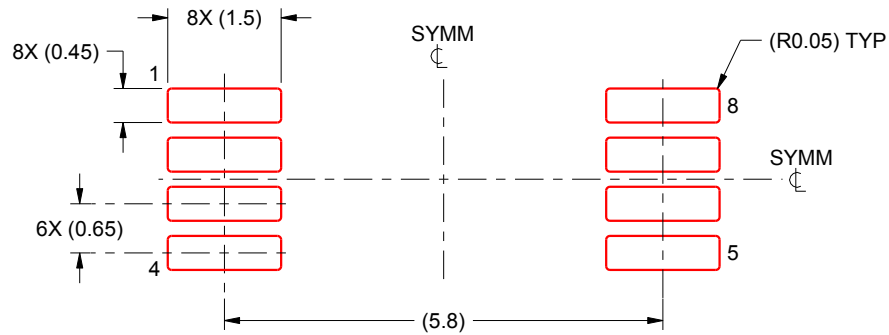

SOLDER PASTE EXAMPLE
BASED ON 0.125 mm THICK STENCIL
SCALE:10X

4221848/A 02/2015

NOTES: (continued)

8. Laser cutting apertures with trapezoidal walls and rounded corners may offer better paste release. IPC-7525 may have alternate design recommendations.
9. Board assembly site may have different recommendations for stencil design.

IMPORTANT NOTICE AND DISCLAIMER

TI PROVIDES TECHNICAL AND RELIABILITY DATA (INCLUDING DATA SHEETS), DESIGN RESOURCES (INCLUDING REFERENCE DESIGNS), APPLICATION OR OTHER DESIGN ADVICE, WEB TOOLS, SAFETY INFORMATION, AND OTHER RESOURCES "AS IS" AND WITH ALL FAULTS, AND DISCLAIMS ALL WARRANTIES, EXPRESS AND IMPLIED, INCLUDING WITHOUT LIMITATION ANY IMPLIED WARRANTIES OF MERCHANTABILITY, FITNESS FOR A PARTICULAR PURPOSE OR NON-INFRINGEMENT OF THIRD PARTY INTELLECTUAL PROPERTY RIGHTS.

These resources are intended for skilled developers designing with TI products. You are solely responsible for (1) selecting the appropriate TI products for your application, (2) designing, validating and testing your application, and (3) ensuring your application meets applicable standards, and any other safety, security, regulatory or other requirements.

These resources are subject to change without notice. TI grants you permission to use these resources only for development of an application that uses the TI products described in the resource. Other reproduction and display of these resources is prohibited. No license is granted to any other TI intellectual property right or to any third party intellectual property right. TI disclaims responsibility for, and you will fully indemnify TI and its representatives against, any claims, damages, costs, losses, and liabilities arising out of your use of these resources.

TI's products are provided subject to [TI's Terms of Sale](#) or other applicable terms available either on ti.com or provided in conjunction with such TI products. TI's provision of these resources does not expand or otherwise alter TI's applicable warranties or warranty disclaimers for TI products.

TI objects to and rejects any additional or different terms you may have proposed.

Mailing Address: Texas Instruments, Post Office Box 655303, Dallas, Texas 75265
Copyright © 2022, Texas Instruments Incorporated