

## 具有 4 通道分组式延迟的 16 通道、恒定电流 LED 驱动器

 查询样品: [TLC59282](#)

### 特性

- 具有开/关控制功能的 16 通道、恒定吸收电流输出
- 功能（恒定电流吸收）：  
**35mA ( $V_{CC} \leq 3.6V$ )**, **45mA ( $V_{CC} > 3.6V$ )**
- **LED** 电源电压高达 **17V**
- **$V_{CC}$**  = **3V** 至 **5.5V**
- 恒定电流准确度：
  - 通道间 =  $\pm 0.6\%$ （典型值）， $\pm 2\%$ （最大值）
  - 器件间 =  $\pm 1\%$ （典型值）， $\pm 3\%$ （最大值）
- 低饱和电压：在 **20 mA**（典型值）时，**0.31 V**
  - $T_A = +25^\circ\text{C}$ ，一个通道开启
- **CMOS** 逻辑电平 I/O
- 数据传输速率：**35 MHz**
- 消隐脉冲宽度：**30 ns**
- 用于降噪的 4 通道分组式延迟
- 工作温度： **$-40^\circ\text{C}$  至  $+85^\circ\text{C}$**

### 应用

- 视频显示器
- 消息板
- 照明

### 说明

TLC59282 是一款 16 通道、恒定吸收电流驱动器。每个通道可利用一种与 3.3V 或 5V CMOS 逻辑电平相兼容（取决于工作  $V_{CC}$ ）的简单串行通信协议进行独立控制。当串行数据缓冲器被加载时，LATCH 上的一个上升沿将把数据传送到 LEDx 输出端。BLANK 引脚可用于在加电及输出数据锁存过程中关断所有的  $OUT_n$  输出，以防止在此期间进行无用的图像显示。所有 16 个通道的恒定电流值均由单个外部电阻器设定。可以将多个 TLC59282 级联起来，以利用同一个处理器来控制额外的 LED。

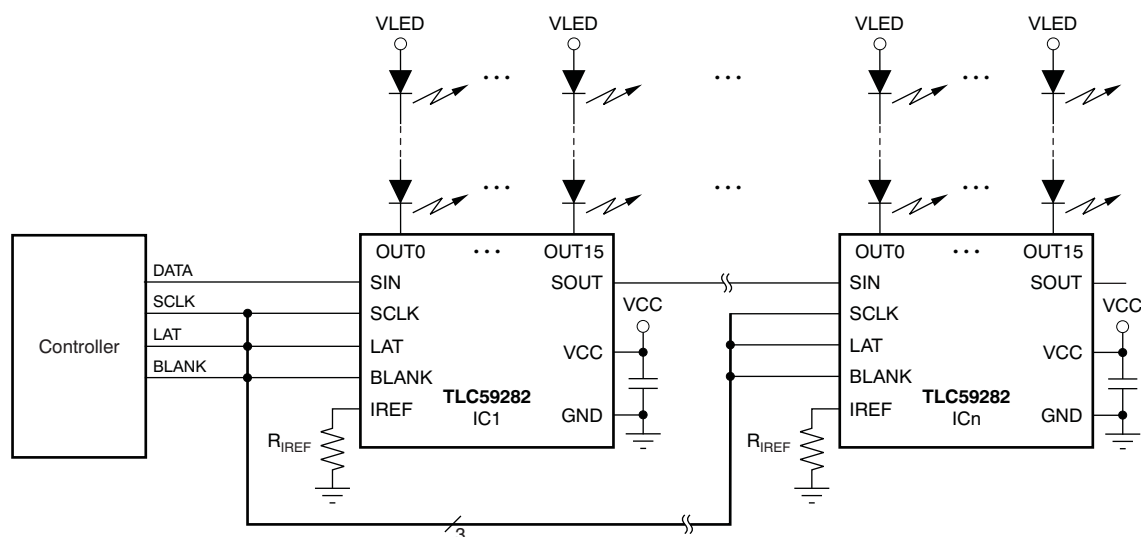

典型应用电路（多重菊花链 TLC59282s）



Please be aware that an important notice concerning availability, standard warranty, and use in critical applications of Texas Instruments semiconductor products and disclaimers thereto appears at the end of this data sheet.

All trademarks are the property of their respective owners.



This integrated circuit can be damaged by ESD. Texas Instruments recommends that all integrated circuits be handled with appropriate precautions. Failure to observe proper handling and installation procedures can cause damage.

ESD damage can range from subtle performance degradation to complete device failure. Precision integrated circuits may be more susceptible to damage because very small parametric changes could cause the device not to meet its published specifications.

### PACKAGE/ORDERING INFORMATION<sup>(1)</sup>

PRODUCT	PACKAGE-LEAD	ORDERING NUMBER	TRANSPORT MEDIA, QUANTITY
TLC59282	SSOP-24/QSOP-24	TLC59282DBQR	Tape and Reel, 2500
		TLC59282DBQ	Tube, 50
TLC59282	QFN-24	TLC59282RGER	Tape and Reel, 3000
		TLC59282RGE	Tape and Reel, 250

(1) For the most current package and ordering information, see the Package Option Addendum at the end of this document, or visit the device product folder at [www.ti.com](http://www.ti.com).

### ABSOLUTE MAXIMUM RATINGS<sup>(1)(2)</sup>

Over operating free-air temperature range, unless otherwise noted.

PARAMETER		TLC59282	UNIT
$V_{CC}$	Supply voltage	-0.3 to +6	V
$I_{OUT}$	Output current (dc) OUT0 to OUT15	50	mA
$V_{IN}$	Input voltage range SIN, SCLK, LAT, BLANK, IREF	-0.3 to $V_{CC} + 0.3$	V
$V_{OUT}$	Output voltage range SOUT	-0.3 to $V_{CC} + 0.3$	V
	OUT0 to OUT15	-0.3 to +18	V
$T_{J(MAX)}$	Operating junction temperature	+150	°C
$T_{STG}$	Storage temperature range	-55 to +150	°C
ESD rating	Human body model (HBM)	4000	V
	Charged device model (CDM)	1000	V

- (1) Stresses above these ratings may cause permanent damage. Exposure to absolute maximum conditions for extended periods may degrade device reliability. These are stress ratings only, and functional operation of the device at these or any other conditions beyond those specified is not supported.
- (2) All voltage values are with respect to network ground terminal.

### THERMAL INFORMATION

THERMAL METRIC <sup>(1)</sup>		TLC59282		UNITS
		DBQ	RGE	
		24 PINS	24 PINS	
$\theta_{JA}$	Junction-to-ambient thermal resistance	73.2	46.8	°C/W
$\theta_{JCTop}$	Junction-to-case (top) thermal resistance	44.6	48.6	
$\theta_{JB}$	Junction-to-board thermal resistance	38.9	23.0	
$\Psi_{JT}$	Junction-to-top characterization parameter	12.3	1.2	
$\Psi_{JB}$	Junction-to-board characterization parameter	39.7	22.9	
$\theta_{JCbott}$	Junction-to-case (bottom) thermal resistance	n/a	6.3	

(1) 有关传统和新的热度的更多信息，请参阅 IC 封装热量应用报告 [SPRA953](#)。

**RECOMMENDED OPERATING CONDITIONS**

 At  $T_A = -40^\circ\text{C}$  to  $+85^\circ\text{C}$ , unless otherwise noted.

PARAMETER	TEST CONDITIONS	TLC59282			UNIT	
		MIN	NOM	MAX		
<b>DC Characteristics: <math>V_{CC} = 3\text{ V}</math> to <math>5.5\text{ V}</math></b>						
$V_{CC}$	Supply voltage		3		5.5	V
$V_O$	Voltage applied to output		OUT0 to OUT15		17	V
$V_{IH}$	High-level input voltage		$0.7 \times V_{CC}$		$V_{CC}$	V
$V_{IL}$	Low-level input voltage		GND		$0.3 \times V_{CC}$	V
$I_{OH}$	High-level output current		SOUT		-1	mA
$I_{OL}$	Low-level output current		SOUT		1	mA
$I_{OLC}$	Constant output sink current		OUT0 to OUT15, $3\text{ V} \leq V_{CC} < 3.6\text{ V}$	2	35	mA
			OUT0 to OUT15, $3.6\text{ V} \leq V_{CC} < 5.5\text{ V}$	2	45	mA
$T_A$	Operating free-air temperature range			-40	+85	$^\circ\text{C}$
$T_J$	Operating junction temperature range			-40	+125	$^\circ\text{C}$
<b>AC Characteristics: <math>V_{CC} = 3\text{ V}</math> to <math>5.5\text{ V}</math></b>						
$f_{CLK}$ (SCLK)	Data shift clock frequency		SCLK		35	MHz
$T_{WH0}$	Pulse duration		SCLK	10		ns
$T_{WL0}$			SCLK	10		ns
$T_{WH1}$			LAT	20		ns
$T_{WH2}$			BLANK	60		ns
$T_{WL2}$			BLANK	30		ns
$T_{SU0}$		Setup time		SIN-SCLK $\uparrow$	4	
$T_{SU1}$			LAT $\downarrow$ -SCLK $\uparrow$	10		ns
$T_{H0}$	Hold time		SIN-SCLK $\uparrow$	4		ns
$T_{H1}$			LAT $\downarrow$ -SCLK $\uparrow$	10		ns

## ELECTRICAL CHARACTERISTICS

At  $V_{CC} = 3\text{ V}$  to  $5.5\text{ V}$  and  $T_A = -40^\circ\text{C}$  to  $+85^\circ\text{C}$ . Typical values at  $V_{CC} = 3.3\text{ V}$  and  $T_A = +25^\circ\text{C}$ , unless otherwise noted.

PARAMETER		TEST CONDITIONS	TLC59282			UNIT	
			MIN	TYP	MAX		
$V_{OH}$	High-level output voltage	$I_{OH} = -1\text{ mA}$ at SOUT	$V_{CC} - 0.4$		$V_{CC}$	V	
$V_{OL}$	Low-level output voltage	$I_{OL} = 1\text{ mA}$ at SOUT			0.4	V	
$I_{IN}$	Input current	$V_{IN} = V_{CC}$ or GND at SIN and SCLK	-1		1	$\mu\text{A}$	
$I_{CC0}$	Supply current ( $V_{CC}$ )	SIN/SCLK/LAT = low, BLANK = high, $V_{OUTn} = 1\text{ V}$ , $R_{REF} = \text{open}$	0.1		1	mA	
$I_{CC1}$		SIN/SCLK/LAT = low, BLANK = high, $V_{OUTn} = 1\text{ V}$ , $R_{REF} = 3\text{ k}\Omega$ ( $I_{OUT} = 16.8\text{ mA}$ target)	4.5		6	mA	
$I_{CC2}$		All $OUTn = \text{ON}$ , SIN/SCLK/LAT/BLANK = low, $V_{OUTn} = 1\text{ V}$ , $R_{REF} = 3\text{ k}\Omega$	7		15	mA	
$I_{CC3}$		All $OUTn = \text{ON}$ , SIN/SCLK/LAT/BLANK = low, $V_{OUTn} = 1\text{ V}$ , $R_{REF} = 1.5\text{ k}\Omega$ ( $I_{OUT} = 33.6\text{ mA}$ target)	16		34	mA	
$I_{OLC}$	Constant output current	All $OUTn = \text{ON}$ , $V_{OUTn} = V_{OUTfix} = 1\text{ V}$ , $R_{REF} = 1.5\text{ k}\Omega$ at $OUT0$ to $OUT15$ (see Figure 6), $T_A = +25^\circ\text{C}$	32.1	33.7	35.3	mA	
$I_{OLKG}$	Output leakage current	$OUTn = \text{OFF}$ , $V_{OUTn} = V_{OUTfix} = 17\text{ V}$ , BLANK = high, $R_{REF} = 1.5\text{ k}\Omega$ at $OUT0$ to $OUT15$ (see Figure 6)			0.1	$\mu\text{A}$	
$\Delta I_{OLC0}$	Constant-current error (channel-to-channel) <sup>(1)</sup>	All $OUTn = \text{ON}$ , $V_{OUTn} = V_{OUTfix} = 1\text{ V}$ , $R_{REF} = 1.5\text{ k}\Omega$ at $OUT0$ to $OUT15$			$\pm 0.6$	$\pm 2$	%
$\Delta I_{OLC1}$	Constant-current error (device-to-device) <sup>(2)</sup>	All $OUTn = \text{ON}$ , $V_{OUTn} = V_{OUTfix} = 1\text{ V}$ , $R_{REF} = 1.5\text{ k}\Omega$ at $OUT0$ to $OUT15$ , $T_A = +25^\circ\text{C}$			$\pm 1$	$\pm 3$	%
$\Delta I_{OLC2}$	Line regulation <sup>(3)</sup>	All $OUTn = \text{ON}$ , $V_{OUTn} = V_{OUTfix} = 1\text{ V}$ , $R_{REF} = 1.5\text{ k}\Omega$ at $OUT0$ to $OUT15$ , $V_{CC} = 3\text{ V}$ to $5.5\text{ V}$			$\pm 0.5$	$\pm 1$	%/V
$\Delta I_{OLC3}$	Load regulation <sup>(4)</sup>	All $OUTn = \text{ON}$ , $V_{OUTn} = 1\text{ V}$ to $3\text{ V}$ , $V_{OUTfix} = 1\text{ V}$ , $R_{REF} = 1.5\text{ k}\Omega$			$\pm 1$	$\pm 3$	%/V
$V_{IREF}$	Reference voltage output	$R_{REF} = 1.5\text{ k}\Omega$ , $T_A = +25^\circ\text{C}$	1.18	1.205	1.23	V	
$R_{PUP}$	Pull-up resistor	BLANK	250	500	750	k $\Omega$	
$R_{PDWN}$	Pull-down resistor	LAT	250	500	750	k $\Omega$	

- (1) The deviation of each output from the average of  $OUT0$ – $OUT15$  constant-current. Deviation is calculated by the formula:

$$\Delta (\%) = \left[ \frac{I_{OUTn}}{\frac{(I_{OUT0} + I_{OUT1} + \dots + I_{OUT14} + I_{OUT15})}{16}} - 1 \right] \times 100$$

- (2) The deviation of the  $OUT0$ – $OUT15$  constant-current average from the ideal constant-current value.

Deviation is calculated by the following formula:

$$\Delta (\%) = \left[ \frac{\frac{(I_{OUT0} + I_{OUT1} + \dots + I_{OUT14} + I_{OUT15})}{16} - (\text{Ideal Output Current})}{\text{Ideal Output Current}} \right] \times 100$$

Ideal current is calculated by the formula:

$$I_{OUT(\text{IDEAL})} = 41.9 \times \left[ \frac{1.205}{R_{REF}} \right]$$

- (3) Line regulation is calculated by this equation:

$$\Delta (\%/V) = \left[ \frac{(I_{OUTn} \text{ at } V_{CC} = 5.5\text{ V}) - (I_{OUTn} \text{ at } V_{CC} = 3\text{ V})}{(I_{OUTn} \text{ at } V_{CC} = 3\text{ V})} \right] \times \frac{100}{5.5\text{ V} - 3\text{ V}}$$

- (4) Load regulation is calculated by the equation:

$$\Delta (\%/V) = \left[ \frac{(I_{OUTn} \text{ at } V_{OUTn} = 3\text{ V}) - (I_{OUTn} \text{ at } V_{OUTn} = 1\text{ V})}{(I_{OUTn} \text{ at } V_{OUTn} = 1\text{ V})} \right] \times \frac{100}{3\text{ V} - 1\text{ V}}$$

## SWITCHING CHARACTERISTICS

At  $V_{CC} = 3\text{ V to }5.5\text{ V}$ ,  $T_A = -40^\circ\text{C to }+85^\circ\text{C}$ ,  $C_L = 15\text{ pF}$ ,  $R_L = 130\ \Omega$ ,  $R_{IREF} = 1.5\text{ k}\Omega$ , and  $V_{LED} = 5.5\text{ V}$ . Typical values at  $V_{CC} = 3.3\text{ V}$  and  $T_A = +25^\circ\text{C}$ , unless otherwise noted.

PARAMETER	TEST CONDITIONS	TLC59282			UNIT
		MIN	TYP	MAX	
$t_{R0}$	Rise time SOUT (see Figure 5)		5	12	ns
$t_{R1}$		OUTn (see Figure 4)		10	
$t_{F0}$	Fall time SOUT (see Figure 5)		5	12	ns
$t_{F1}$		OUTn (see Figure 4)		10	
$t_{D0}$	Propagation delay time LAT $\uparrow$ or BLANK $\uparrow\downarrow$ to OUT0/OUT7/OUT8/OUT15 on/off	SCLK $\uparrow$ to SOUT $\uparrow\downarrow$	8	20	ns
$t_{D1}$		LAT $\uparrow$ or BLANK $\uparrow\downarrow$ to OUT1/OUT6/OUT9/OUT14 on/off	18	36	ns
$t_{D2}$		LAT $\uparrow$ or BLANK $\uparrow\downarrow$ to OUT1/OUT6/OUT9/OUT14 on/off	38	69	ns
$t_{D3}$		LAT $\uparrow$ or BLANK $\uparrow\downarrow$ to OUT2/OUT5/OUT10/OUT13 on/off	58	102	ns
$t_{D4}$		LAT $\uparrow$ or BLANK $\uparrow\downarrow$ to OUT3/OUT4/OUT11/OUT12 on/off	78	135	ns
$t_{ON\_ERR}$	Output on-time error <sup>(1)</sup> On/off latch data = all '1', 30 ns BLANK low level one-shot pulse input	-15		15	ns

(1) Output on-time error ( $t_{ON\_ERR}$ ) is calculated by the formula:  $t_{ON\_ERR}\text{ (ns)} = t_{OUT\_ON} - \text{BLANK low level one-shot pulse width (}T_{WL2}\text{)}$ .  $t_{OUT\_ON}$  indicates the actual on-time of the constant-current output.

## FUNCTIONAL BLOCK DIAGRAM

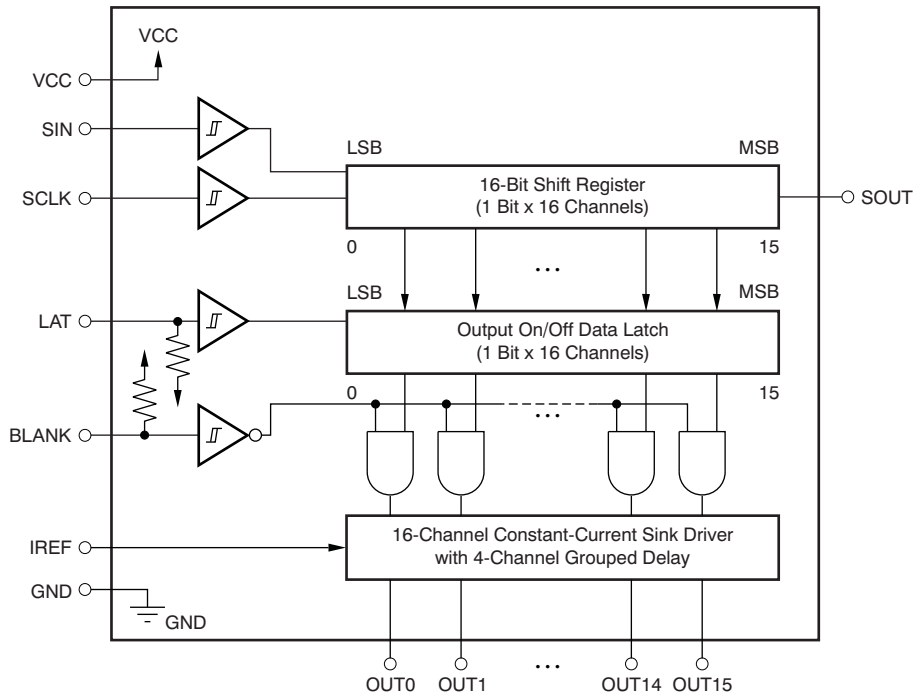

### DEVICE INFORMATION

**SSOP-24/QSOP-24  
DBQ PACKAGE  
(TOP VIEW)**

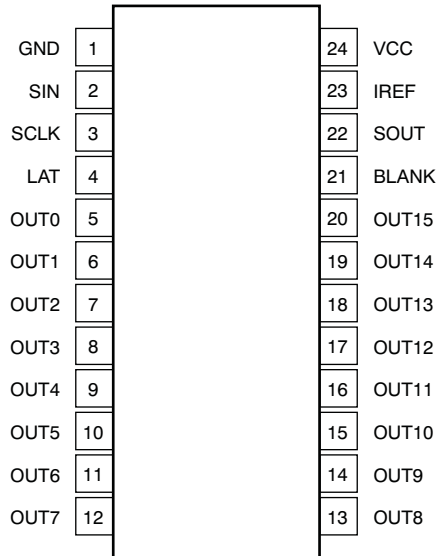

**QFN-24  
RGE PACKAGE  
(TOP VIEW)**

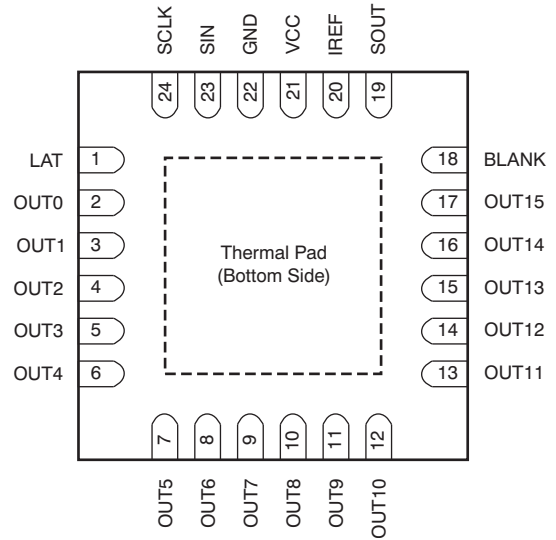

NOTE: Thermal pad is not connected to GND internally. The thermal pad must be connected to GND via the PCB pattern.

**TERMINAL FUNCTIONS**

TERMINAL			I/O	DESCRIPTION
NAME	DBQ	RGE		
SIN	2	23	I	Serial data input for driver on/off control; Schmitt buffer input. When SIN is high, data '1' are written into the LSB of the 16-bit shift register at the SCLK rising edge.
SCLK	3	24	I	Serial data shift clock; Schmitt buffer input. All data in the 16-bit shift register are shifted toward the MSB by 1-bit synchronization of SCLK.
LAT	4	1	I	Level triggered latch; Schmitt buffer input. The data in the 16-bit shift register continue to transfer to the output on/off data latch while LAT is high. Therefore, if the data in the 16-bit shift register are changed when LAT is high, the data in the data latch are also changed. The data in the data latch are held when LAT is low. This pin is internally pulled down to GND with a 500 k $\Omega$ (typ) resistor.
BLANK	21	18	I	Blank, all outputs; Schmitt buffer input. When BLANK is high, all constant-current outputs (OUT0–OUT15) are forced off. When BLANK is low, all constant-current outputs are controlled by the data in the output on/off data latch. This pin is internally pulled up to V <sub>CC</sub> with a 500 k $\Omega$ (typ) resistor.
IREF	23	20	I/O	Constant-current value setting, OUT0–OUT15 sink constant-current is set to desired value by connection to an external resistor between IREF and GND.
SOUT	22	19	O	Serial data output. This output is connected to the MSB of the 16-bit shift register. SOUT data changes at the rising edge of SCLK.
OUT0	5	2	O	Constant-current output. Each output can be tied together with others to increase the constant-current. Different voltages can be applied to each output.
OUT1	6	3	O	Constant-current output
OUT2	7	4	O	Constant-current output
OUT3	8	5	O	Constant-current output
OUT4	9	6	O	Constant-current output
OUT5	10	7	O	Constant-current output
OUT6	11	8	O	Constant-current output
OUT7	12	9	O	Constant-current output
OUT8	13	10	O	Constant-current output
OUT9	14	11	O	Constant-current output
OUT10	15	12	O	Constant-current output
OUT11	16	13	O	Constant-current output
OUT12	17	14	O	Constant-current output
OUT13	18	15	O	Constant-current output
OUT14	19	16	O	Constant-current output
OUT15	20	17	O	Constant-current output
VCC	24	21	—	Power-supply voltage
GND	1	22	—	Power ground

PARAMETER MEASUREMENT INFORMATION

PIN EQUIVALENT INPUT AND OUTPUT SCHEMATIC DIAGRAMS

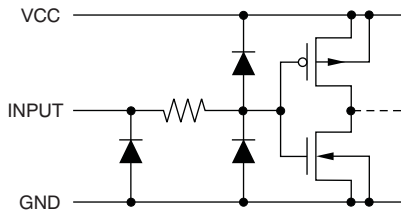

Figure 1. SIN, SCLK, LAT, BLANK

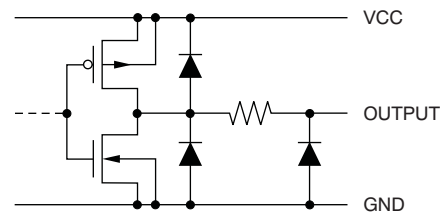

Figure 2. SOUT

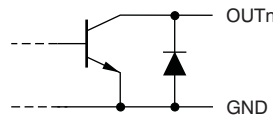
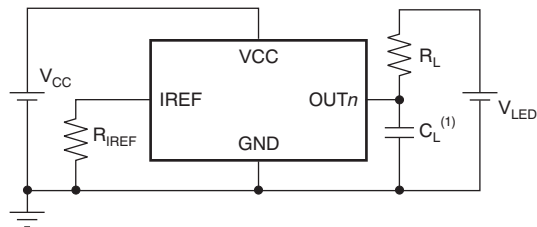

Figure 3. OUT0 Through OUT15

TEST CIRCUITS



(1)  $C_L$  includes measurement probe and jig capacitance.

Figure 4. Rise Time and Fall Time Test Circuit for  $OUT_n$

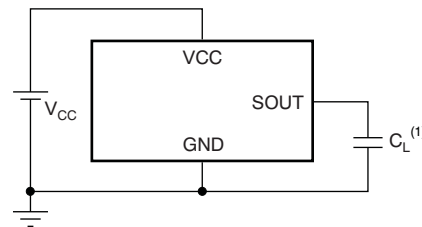

(1)  $C_L$  includes measurement probe and jig capacitance.

Figure 5. Rise Time and Fall Time Test Circuit for SOUT

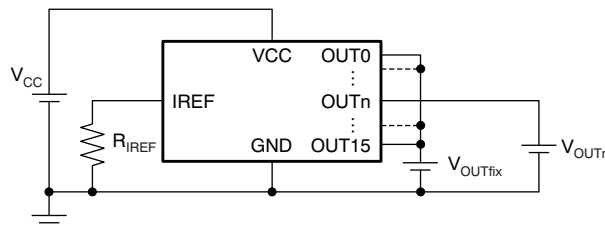
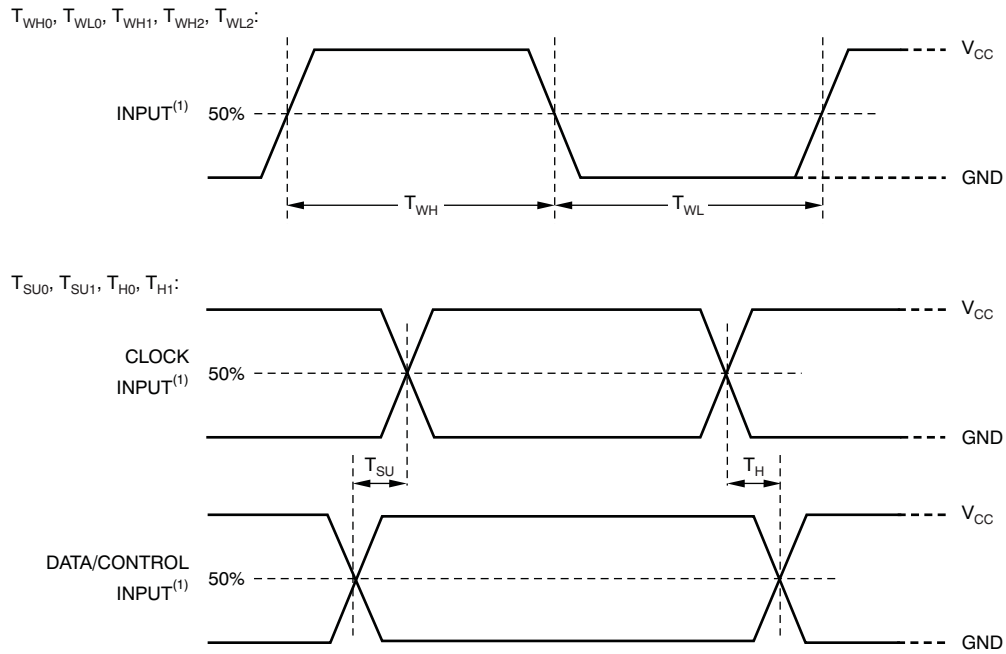

Figure 6. Constant-Current Test Circuit for  $OUT_n$

**TIMING DIAGRAMS**



(1) Input pulse rise and fall time is 1 ns to 3 ns.

**Figure 7. Input Timing**

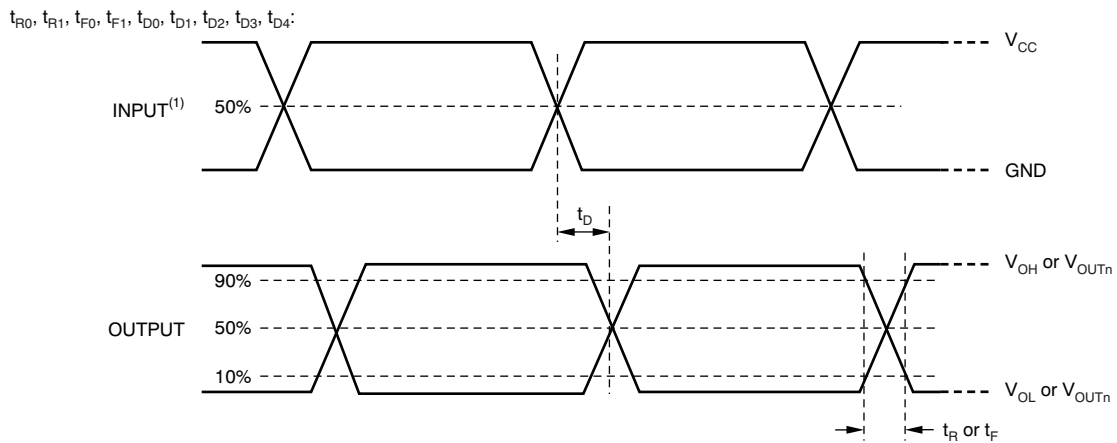

(1) Input pulse rise and fall time is 1 ns to 3 ns.

**Figure 8. Output Timing**

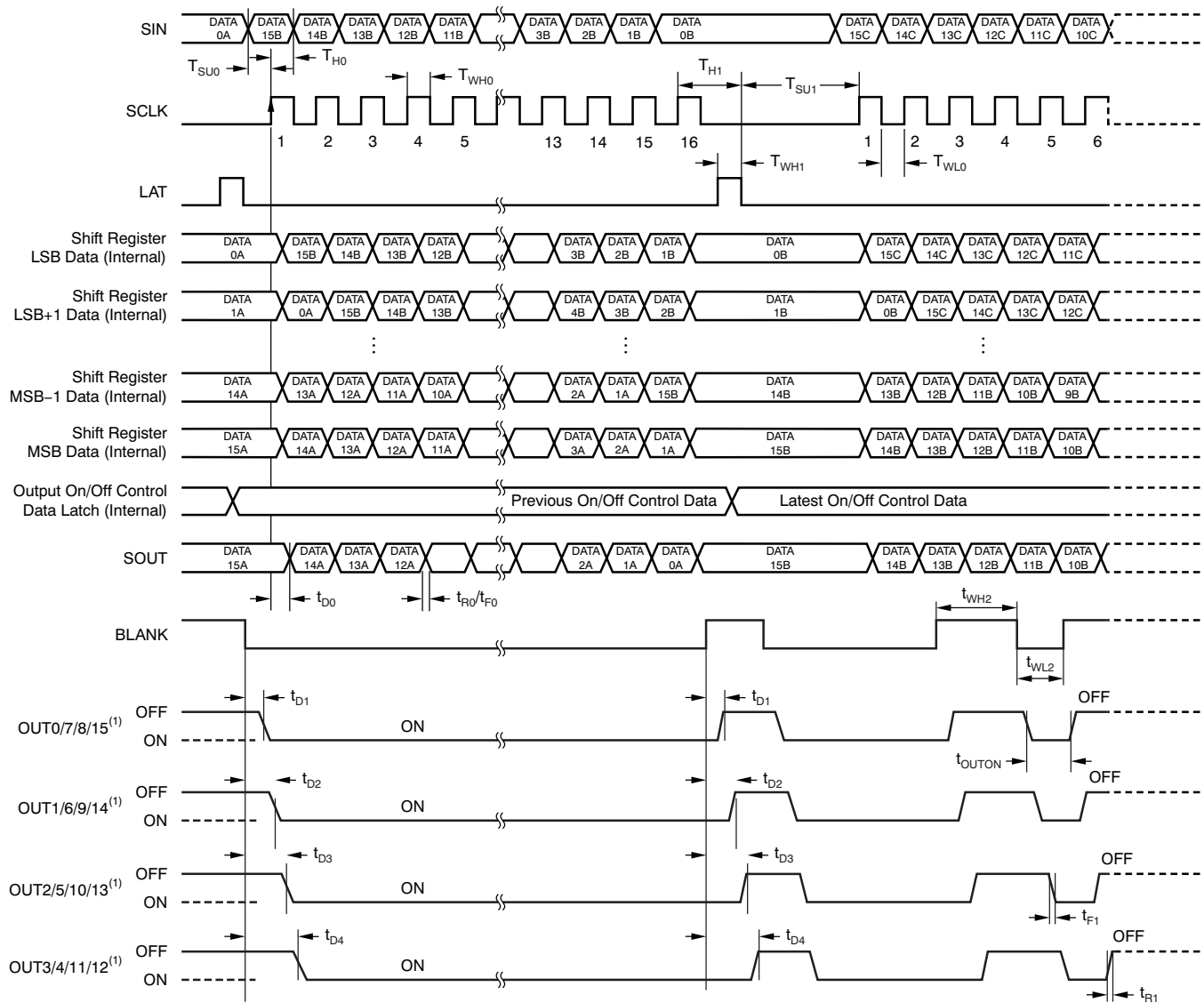

(1) Output on/off data = FFFFh.

(2)  $t_{ON\_ERR} = t_{OUTON} - T_{WL2}$ .

Figure 9. Timing Diagram

### TYPICAL CHARACTERISTICS

At  $V_{CC} = 3.3\text{ V}$  and  $T_A = +25^\circ\text{C}$ , unless otherwise noted.

**REFERENCE RESISTOR vs OUTPUT CURRENT**

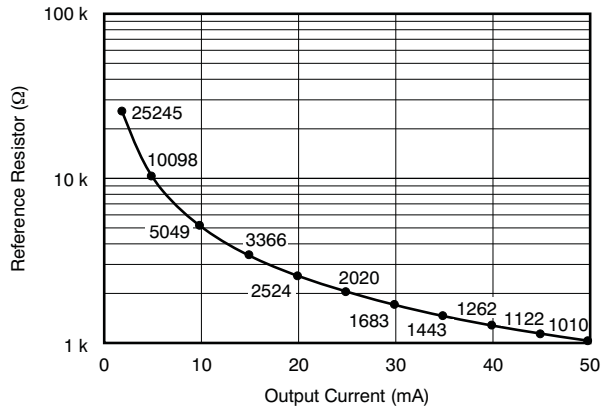

Figure 10.

**OUTPUT CURRENT vs OUTPUT VOLTAGE**

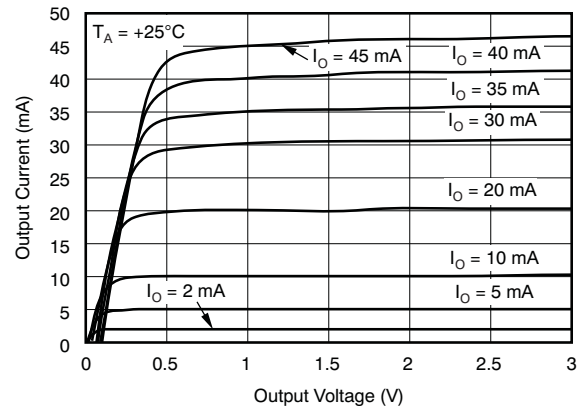

Figure 11.

**OUTPUT CURRENT vs OUTPUT VOLTAGE**

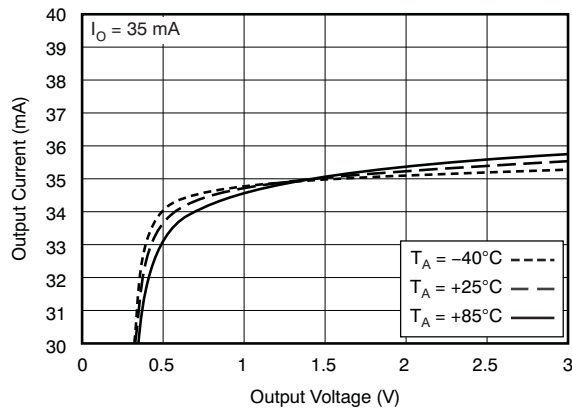

Figure 12.

**$\Delta I_{OLC}$  vs AMBIENT TEMPERATURE**

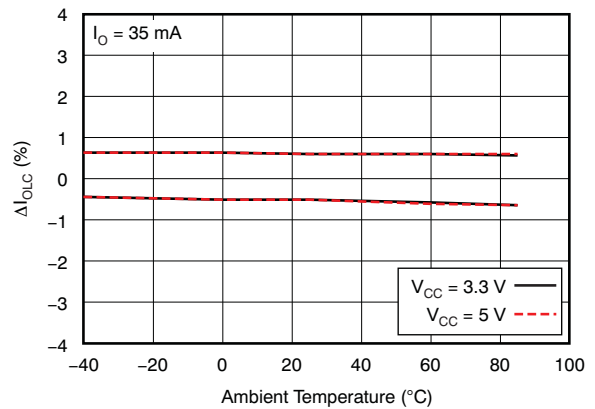

Figure 13.

**$\Delta I_{OLC}$  vs OUTPUT CURRENT**

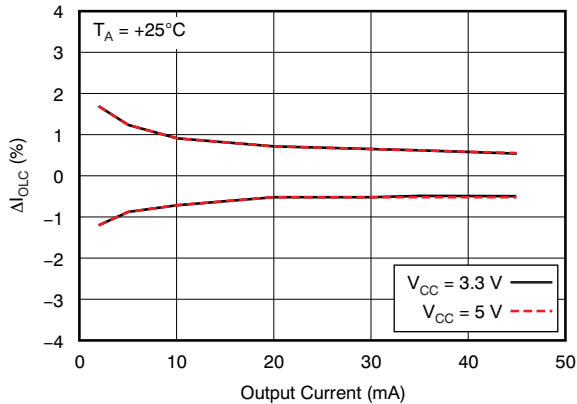

Figure 14.

**CONSTANT-CURRENT OUTPUT VOLTAGE WAVEFORM**

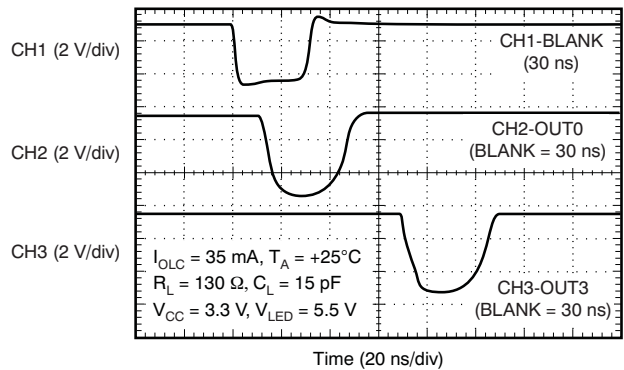

Figure 15.

## DETAILED DESCRIPTION

### SETTING FOR THE CONSTANT SINK CURRENT VALUE

The constant-current values are determined by an external resistor ( $R_{IREF}$ ) placed between IREF and GND. The resistor ( $R_{IREF}$ ) value is calculated by [Equation 1](#).

$$R_{IREF} \text{ (k}\Omega\text{)} = \frac{V_{IREF} \text{ (V)}}{I_{OLC} \text{ (mA)}} \times 41.9$$

Where:

$$V_{IREF} = \text{the internal reference voltage on the IREF pin (typically 1.205 V)} \quad (1)$$

$I_{OLC}$  must be set in the range of 2 mA to 35 mA when  $V_{CC}$  is less than 3.6 V. Also, when  $V_{CC}$  is equal to 3.6 V or greater,  $I_{OLC}$  must be set in the range of 2 mA to 45 mA. The constant sink current characteristic for the external resistor value is shown in [Figure 10](#). [Table 1](#) describes the constant-current output versus external resistor value.

**Table 1. Constant-Current Output versus External Resistor Value**

$I_{OLC}$ (mA, Typical)	$R_{IREF}$ (k $\Omega$ )
45 ( $V_{CC} > 3.6$ V only)	1.12
40 ( $V_{CC} > 3.6$ V only)	1.26
35	1.44
30	1.68
25	2.02
20	2.52
15	3.37
10	5.05
5	10.1
2	25.2

### CONSTANT-CURRENT DRIVER ON/OFF CONTROL

When BLANK is low, the corresponding output is turned on if the data in the on/off control data latch are '1' and remains off if the data are '0'. When BLANK is high, all outputs are forced off. This control is shown in [Table 2](#).

**Table 2. On/Off Control Data Truth Table**

OUTPUT ON/OFF DATA	CONSTANT-CURRENT OUTPUT STATUS
0	Off
1	On

When the IC is initially powered on, the data in the 16-bit shift register and output on/off data latch are not set to the respective default value. Therefore, the output on/off data must be written to the data latch before turning the constant-current output on. BLANK should be at a high level when powered on because the constant-current may be turned on as a result of random data in the output on/off data latch.

The output on/off data corresponding to any unconnected OUTn outputs should be set to '0' before turning on the remaining outputs. Otherwise, the supply current ( $I_{CC}$ ) increases while the LEDs are on.

## REGISTER CONFIGURATION

The TLC59282 has a 16-bit shift register and an output on/off data latch. Both the shift register and data latch are 16 bits long and are used to turn the constant-current outputs on and off. Figure 16 shows the shift register and data latch configuration. The data at the SIN pin are shifted in to the LSB of the 16-bit shift register at the rising edge of the SCLK pin; SOUT data change at the rising edge of SCLK.

The output on/off data in the 16-bit shift register continue to transfer to the output on/off data latch while LAT is high. Therefore, if the data in the 16-bit shift register are changed when LAT is high, the data in the data latch are also changed. The data in the data latch are held when LAT is low. When the IC initially powers on, the data in the output on/off shift register and latch are not set to the default values; on/off control data must be written to the on/off control data latch before turning the constant-current output on. BLANK should be high when the IC is powered on because the constant-current may be turned on at that time as a result of random values in the on/off data latch. All constant-current outputs are forced off when BLANK is high. The OUTn on/off are controlled by the data in the output on/off data latch. The timing diagram and truth table for writing data are shown in Figure 17 and Table 3.

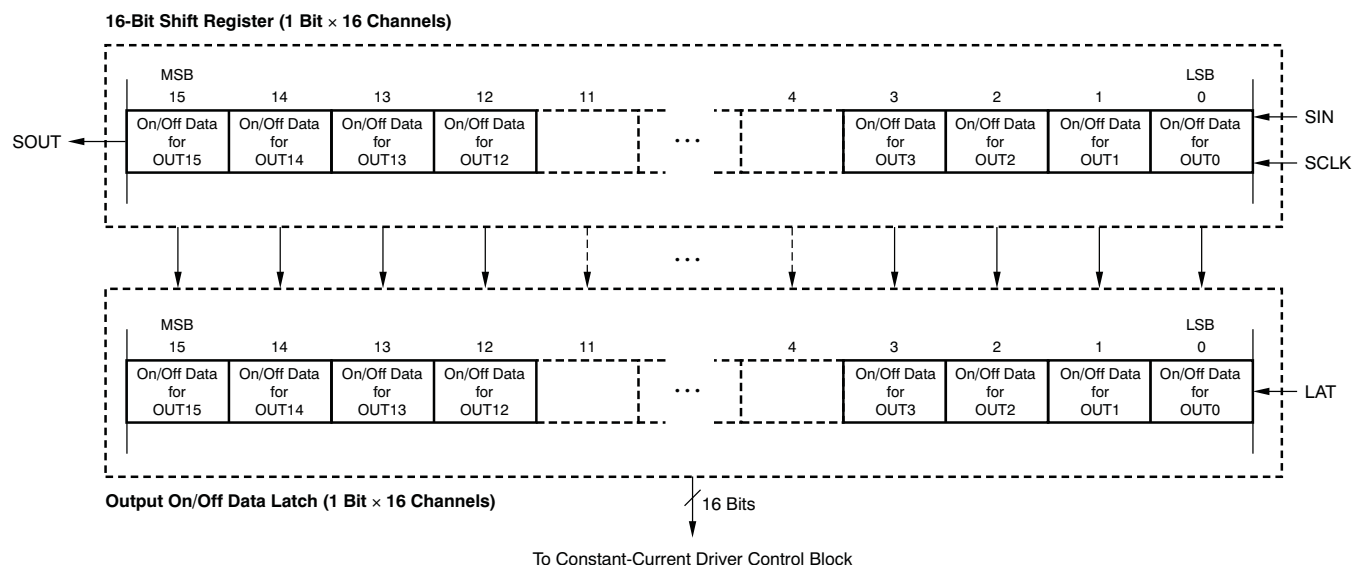

Figure 16. 16-Bit Shift Register and Output On/Off Data Latch Configuration

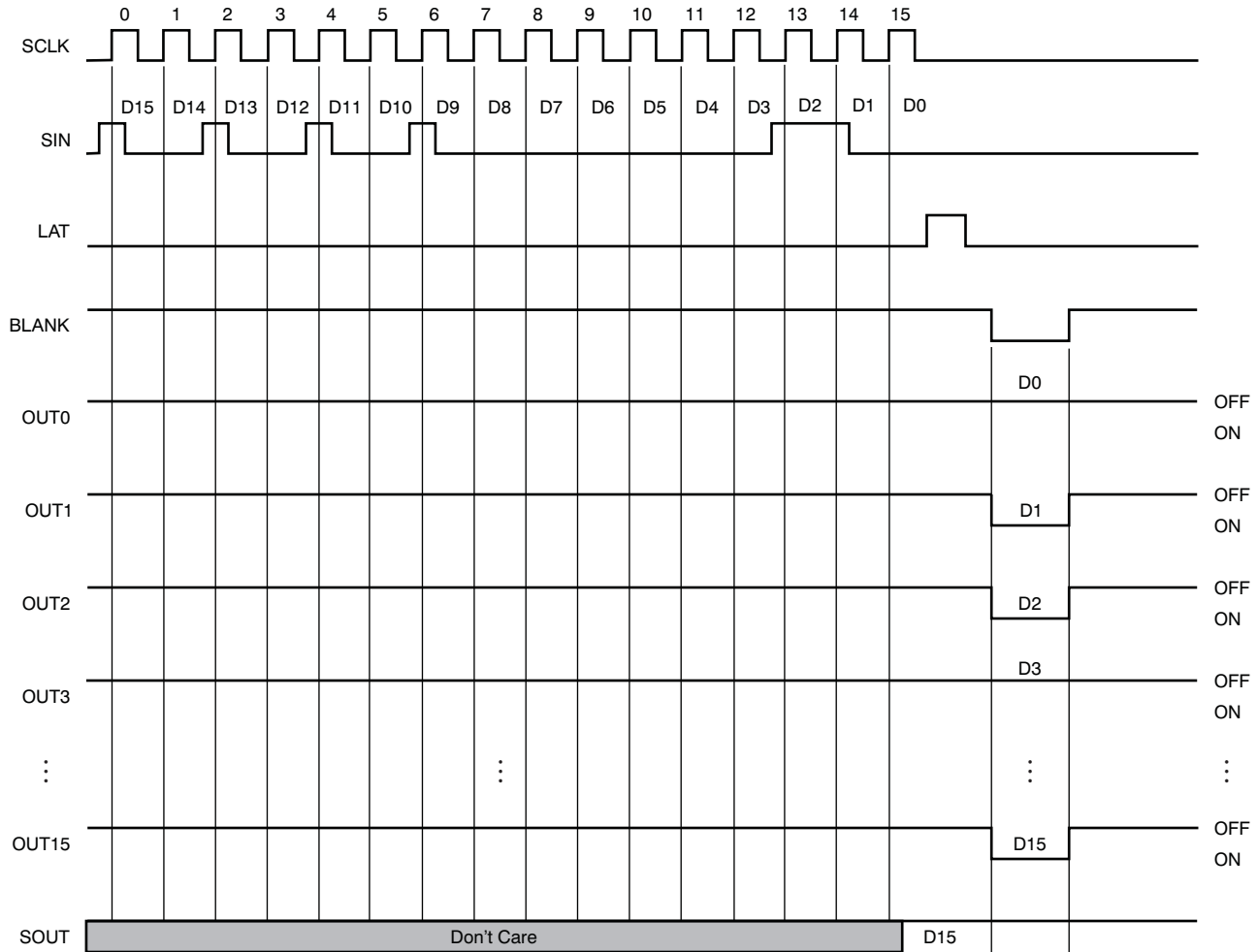

Figure 17. Operation Timing Diagram

Table 3. Truth Table in Operation

SCLK	LAT	BLANK	SIN	OUT0...OUT7...OUT15	SOUT
↑	High	Low	Dn	Dn...Dn – 7...Dn – 15	Dn – 15
↑	Low	Low	Dn + 1	No change	Dn – 14
↑	High	Low	Dn + 2	Dn + 2...Dn – 5...Dn – 13	Dn – 13
↓	—	Low	Dn + 3	Dn + 2...Dn – 5...Dn – 13	Dn – 13
↓	—	High	Dn + 3	Off	Dn – 13

**NOISE REDUCTION**

Large surge currents may flow through the IC and the board if all 16 outputs turn on or off simultaneously. These large current surges could induce detrimental noise and electromagnetic interference (EMI) into other circuits. The TLC59282 independently turns on or off the outputs for each color group with a 20 ns (typ) delay time; see Figure 9. The output current sinks are grouped into four groups. The first group that is turned on/off are OUT0/7/8/15; the second group that is turned on/off are OUT1/6/9/14; the third group that is turned on/off are OUT2/5/10/13; and the fourth group is OUT3/4/11/12. Both turn-on and turn-off are delayed. However, the state of each output is controlled by the data in the output on-off data latch and BLANK level.

## REVISION HISTORY

NOTE: Page numbers for previous revisions may differ from page numbers in the current version.

---

### Changes from Revision B (July 2011) to Revision C Page

- Added 低饱和电压 特性 ..... 1
- 

---

### Changes from Revision A (December 2010) to Revision B Page

- Changed 恒定电流准确度特性 ..... 1
  - Added RGE package information to *Package/Ordering Information* table ..... 2
  - Added RGE package to *Thermal Information* table ..... 2
  - Changed *Input current* parameter test conditions in Electrical Characteristics table ..... 4
  - Added RGE pin out and footnote to *Device Information* section ..... 6
  - Added RGE information to *Terminal Functions* table ..... 7
  - Deleted Figure 11, *POWER DISSIPATION RATE vs FREE-AIR TEMPERATURE* ..... 11
-

**PACKAGING INFORMATION**

Orderable Device	Status (1)	Package Type	Package Drawing	Pins	Package Qty	Eco Plan (2)	Lead finish/ Ball material (6)	MSL Peak Temp (3)	Op Temp (°C)	Device Marking (4/5)	Samples
TLC59282DBQ	ACTIVE	SSOP	DBQ	24	50	RoHS & Green	NIPDAU	Level-2-260C-1 YEAR	-40 to 85	TLC59282	<a href="#">Samples</a>
TLC59282DBQR	ACTIVE	SSOP	DBQ	24	2500	RoHS & Green	NIPDAU	Level-2-260C-1 YEAR	-40 to 85	TLC59282	<a href="#">Samples</a>
TLC59282RGER	ACTIVE	VQFN	RGE	24	3000	RoHS & Green	NIPDAU	Level-2-260C-1 YEAR	-40 to 85	TLC 59282	<a href="#">Samples</a>
TLC59282RGET	ACTIVE	VQFN	RGE	24	250	RoHS & Green	NIPDAU	Level-2-260C-1 YEAR	-40 to 85	TLC 59282	<a href="#">Samples</a>

(1) The marketing status values are defined as follows:

**ACTIVE:** Product device recommended for new designs.

**LIFEBUY:** TI has announced that the device will be discontinued, and a lifetime-buy period is in effect.

**NRND:** Not recommended for new designs. Device is in production to support existing customers, but TI does not recommend using this part in a new design.

**PREVIEW:** Device has been announced but is not in production. Samples may or may not be available.

**OBSOLETE:** TI has discontinued the production of the device.

(2) **RoHS:** TI defines "RoHS" to mean semiconductor products that are compliant with the current EU RoHS requirements for all 10 RoHS substances, including the requirement that RoHS substance do not exceed 0.1% by weight in homogeneous materials. Where designed to be soldered at high temperatures, "RoHS" products are suitable for use in specified lead-free processes. TI may reference these types of products as "Pb-Free".

**RoHS Exempt:** TI defines "RoHS Exempt" to mean products that contain lead but are compliant with EU RoHS pursuant to a specific EU RoHS exemption.

**Green:** TI defines "Green" to mean the content of Chlorine (Cl) and Bromine (Br) based flame retardants meet JS709B low halogen requirements of <=1000ppm threshold. Antimony trioxide based flame retardants must also meet the <=1000ppm threshold requirement.

(3) MSL, Peak Temp. - The Moisture Sensitivity Level rating according to the JEDEC industry standard classifications, and peak solder temperature.

(4) There may be additional marking, which relates to the logo, the lot trace code information, or the environmental category on the device.

(5) Multiple Device Markings will be inside parentheses. Only one Device Marking contained in parentheses and separated by a "~" will appear on a device. If a line is indented then it is a continuation of the previous line and the two combined represent the entire Device Marking for that device.

(6) Lead finish/Ball material - Orderable Devices may have multiple material finish options. Finish options are separated by a vertical ruled line. Lead finish/Ball material values may wrap to two lines if the finish value exceeds the maximum column width.

**Important Information and Disclaimer:**The information provided on this page represents TI's knowledge and belief as of the date that it is provided. TI bases its knowledge and belief on information provided by third parties, and makes no representation or warranty as to the accuracy of such information. Efforts are underway to better integrate information from third parties. TI has taken and

continues to take reasonable steps to provide representative and accurate information but may not have conducted destructive testing or chemical analysis on incoming materials and chemicals. TI and TI suppliers consider certain information to be proprietary, and thus CAS numbers and other limited information may not be available for release.

In no event shall TI's liability arising out of such information exceed the total purchase price of the TI part(s) at issue in this document sold by TI to Customer on an annual basis.

**TAPE AND REEL INFORMATION**

**QUADRANT ASSIGNMENTS FOR PIN 1 ORIENTATION IN TAPE**



\*All dimensions are nominal

Device	Package Type	Package Drawing	Pins	SPQ	Reel Diameter (mm)	Reel Width W1 (mm)	A0 (mm)	B0 (mm)	K0 (mm)	P1 (mm)	W (mm)	Pin1 Quadrant
TLC59282DBQR	SSOP	DBQ	24	2500	330.0	16.4	6.5	9.0	2.1	8.0	16.0	Q1
TLC59282RGER	VQFN	RGE	24	3000	330.0	12.4	4.25	4.25	1.15	8.0	12.0	Q2
TLC59282RGET	VQFN	RGE	24	250	180.0	12.4	4.25	4.25	1.15	8.0	12.0	Q2

**TAPE AND REEL BOX DIMENSIONS**

\*All dimensions are nominal

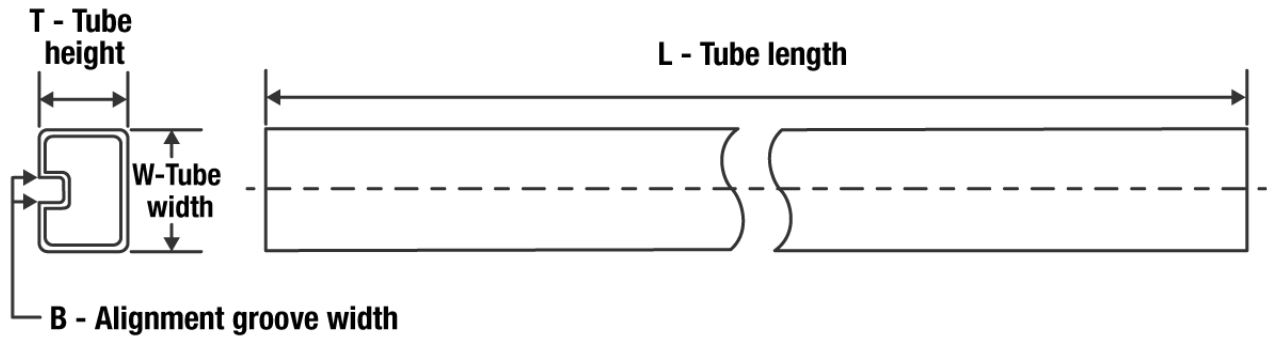
Device	Package Type	Package Drawing	Pins	SPQ	Length (mm)	Width (mm)	Height (mm)
TLC59282DBQR	SSOP	DBQ	24	2500	367.0	367.0	38.0
TLC59282RGER	VQFN	RGE	24	3000	853.0	449.0	35.0
TLC59282RGET	VQFN	RGE	24	250	210.0	185.0	35.0

**TUBE**

\*All dimensions are nominal

Device	Package Name	Package Type	Pins	SPQ	L (mm)	W (mm)	T (μm)	B (mm)
TLC59282DBQ	DBQ	SSOP	24	50	506.6	8	3940	4.32

**RGE 24**

**GENERIC PACKAGE VIEW**

**VQFN - 1 mm max height**

PLASTIC QUAD FLATPACK - NO LEAD

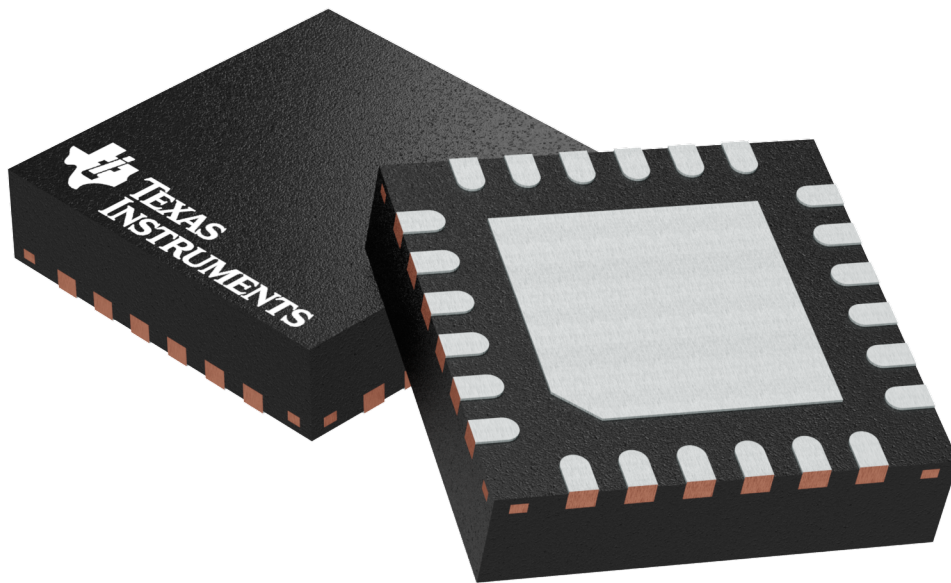

Images above are just a representation of the package family, actual package may vary.  
Refer to the product data sheet for package details.

4204104/H

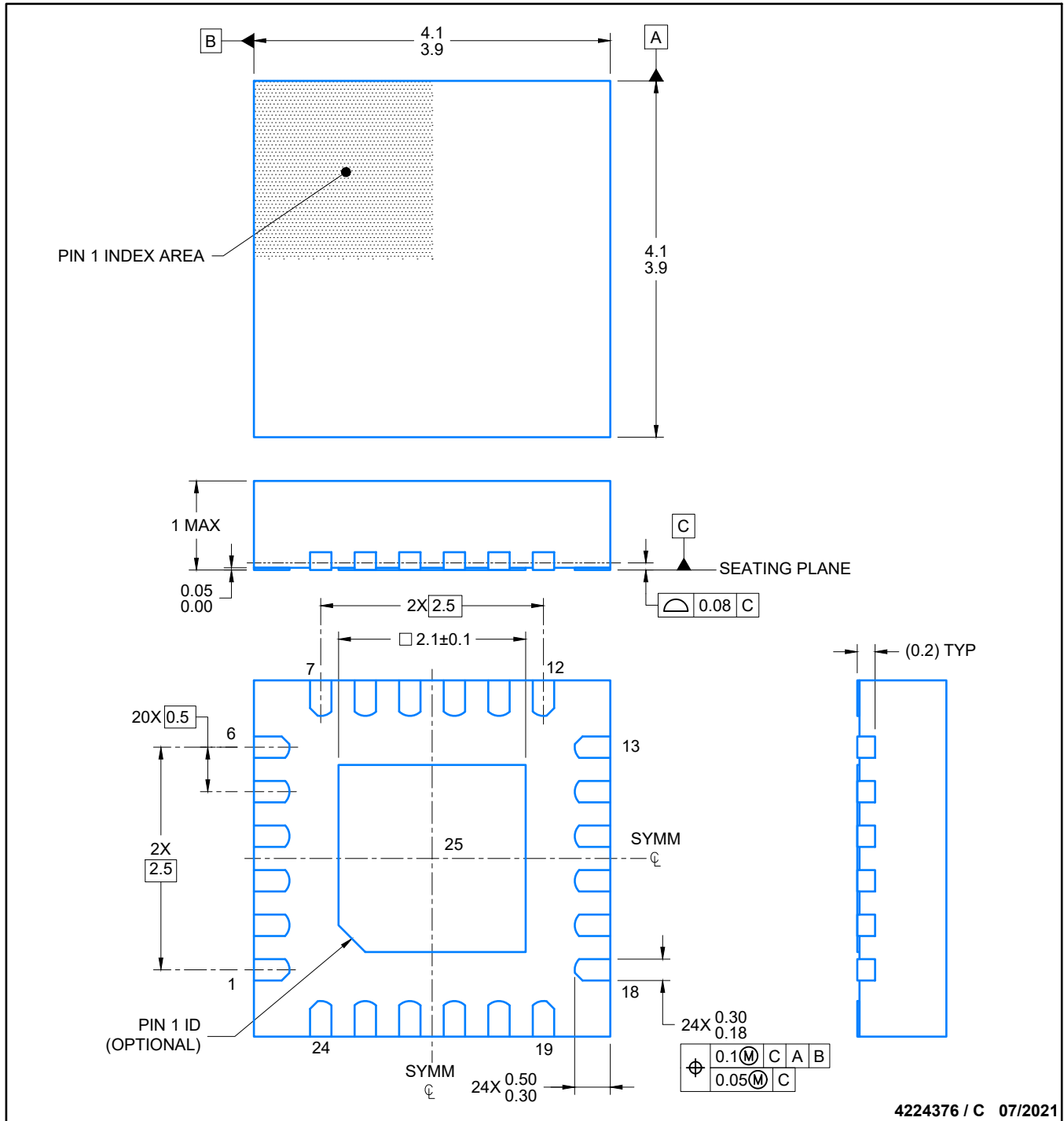

4224376 / C 07/2021

NOTES:

1. All linear dimensions are in millimeters. Any dimensions in parenthesis are for reference only. Dimensioning and tolerancing per ASME Y14.5M.
2. This drawing is subject to change without notice.
3. The package thermal pad must be soldered to the printed circuit board for thermal and mechanical performance.

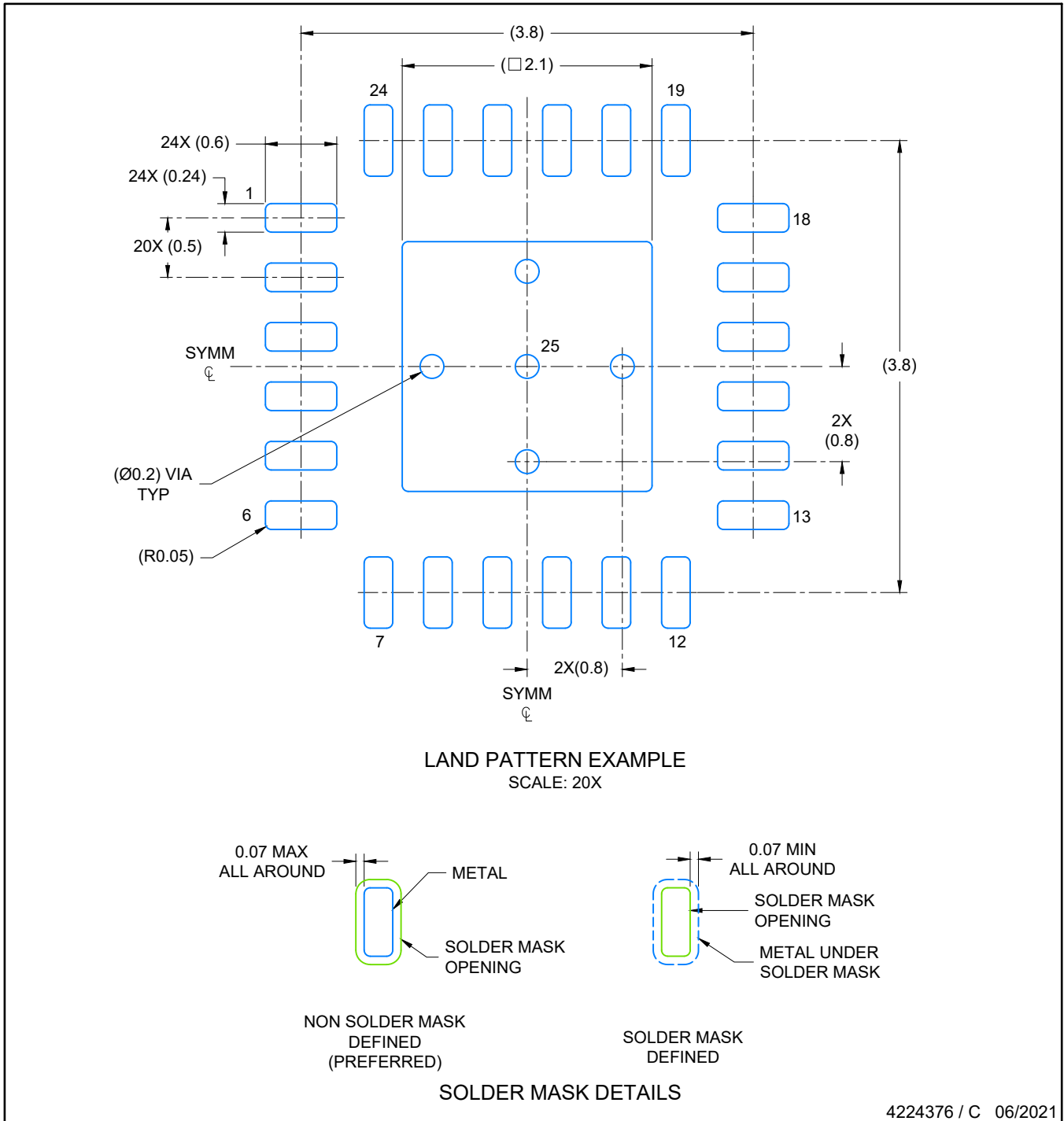

4224376 / C 06/2021

NOTES: (continued)

4. This package is designed to be soldered to a thermal pad on the board. For more information, see Texas Instruments literature number SLUA271 ([www.ti.com/lit/slua271](http://www.ti.com/lit/slua271)).
5. Solder mask tolerances between and around signal pads can vary based on board fabrication site.

# EXAMPLE STENCIL DESIGN

RGE0024C

VQFN - 1 mm max height

PLASTIC QUAD FLATPACK- NO LEAD

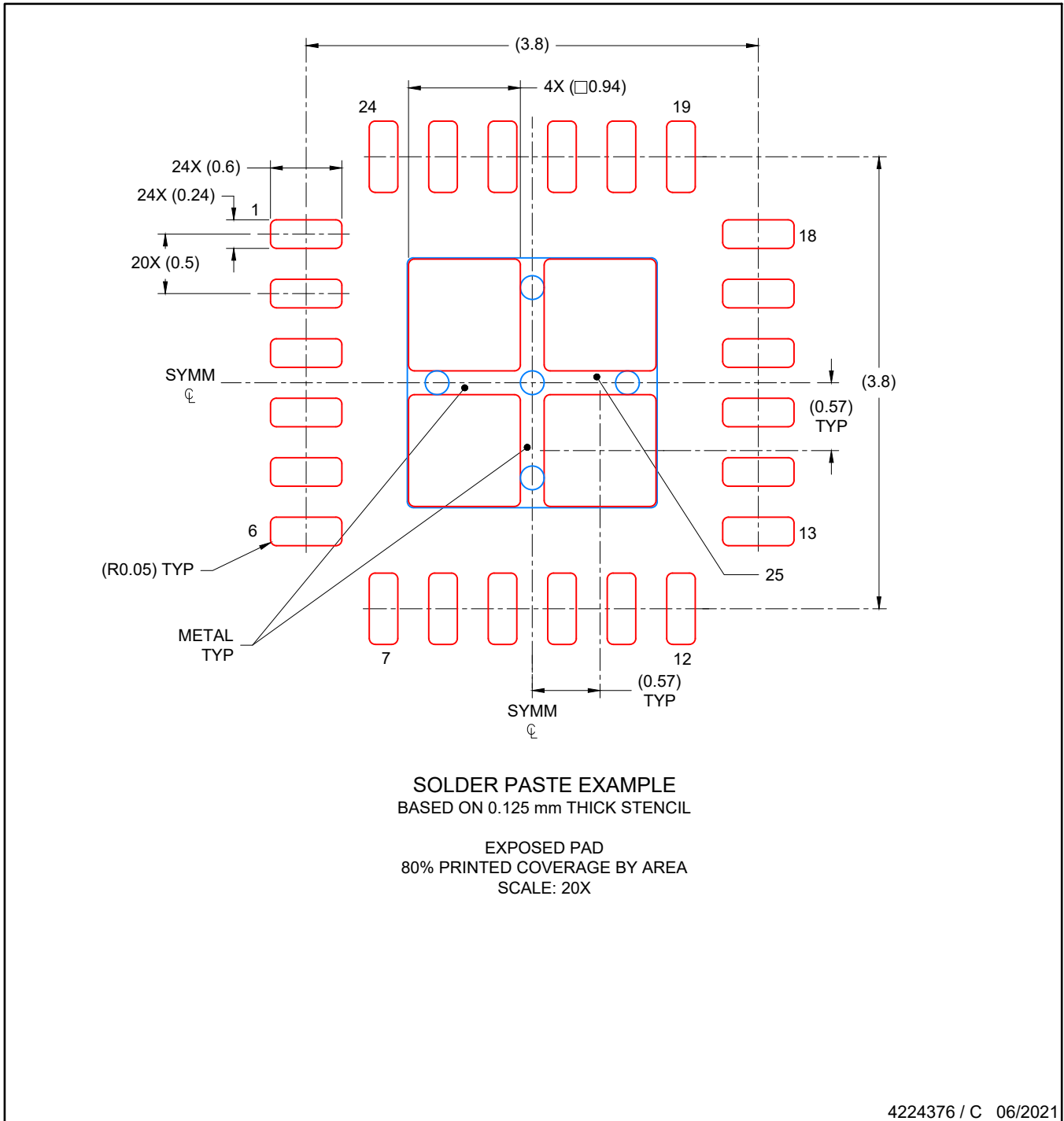

NOTES: (continued)

6. Laser cutting apertures with trapezoidal walls and rounded corners may offer better paste release. IPC-7525 may have alternate design recommendations..



## 重要声明和免责声明

TI“按原样”提供技术和可靠性数据（包括数据表）、设计资源（包括参考设计）、应用或其他设计建议、网络工具、安全信息和其他资源，不保证没有瑕疵且不做任何明示或暗示的担保，包括但不限于对适销性、某特定用途方面的适用性或不侵犯任何第三方知识产权的暗示担保。

这些资源可供使用 TI 产品进行设计的熟练开发人员使用。您将自行承担以下全部责任：(1) 针对您的应用选择合适的 TI 产品，(2) 设计、验证并测试您的应用，(3) 确保您的应用满足相应标准以及任何其他功能安全、信息安全、监管或其他要求。

这些资源如有变更，恕不另行通知。TI 授权您仅可将这些资源用于研发本资源所述的 TI 产品的应用。严禁对这些资源进行其他复制或展示。您无权使用任何其他 TI 知识产权或任何第三方知识产权。您应全额赔偿因在这些资源的使用中对 TI 及其代表造成的任何索赔、损害、成本、损失和债务，TI 对此概不负责。

TI 提供的产品受 [TI 的销售条款](#) 或 [ti.com](#) 上其他适用条款/TI 产品随附的其他适用条款的约束。TI 提供这些资源并不会扩展或以其他方式更改 TI 针对 TI 产品发布的适用的担保或担保免责声明。

TI 反对并拒绝您可能提出的任何其他或不同的条款。

邮寄地址：Texas Instruments, Post Office Box 655303, Dallas, Texas 75265

Copyright © 2022，德州仪器 (TI) 公司