

## TLE4275-Q1 5-V Low-Dropout Voltage Regulator

### 1 Features

- Qualified for Automotive Applications
- Output Voltage 5 V  $\pm$  2%
- Very Low Current Consumption
- Power-On and Undervoltage Reset
- Reset Low-Level Output Voltage < 1 V
- Very Low Dropout Voltage
- Short-Circuit Proof
- Reverse-Polarity Proof

### 2 Applications

- Qualified for Automotive Applications
- Cluster
- Body Control Modules
- Heating Ventilation and Air Conditioning (HVAC)

### 3 Description

The TLE4275-Q1 is a monolithic integrated low-dropout voltage regulator offered in a 5-pin TO package. The device regulates an input voltage up to 45 V to  $V_{OUT} = 5$  V (typical). The device can drive loads up to 450 mA and is short-circuit proof. At overtemperature, the incorporated temperature protection turns off the TLE4275-Q1. The device generates a reset signal for an output voltage,  $V_{OUT,rt}$ , of 4.65 V (typical). By the use of an external delay capacitor, one can program the reset delay time.

### 4 Typical Application

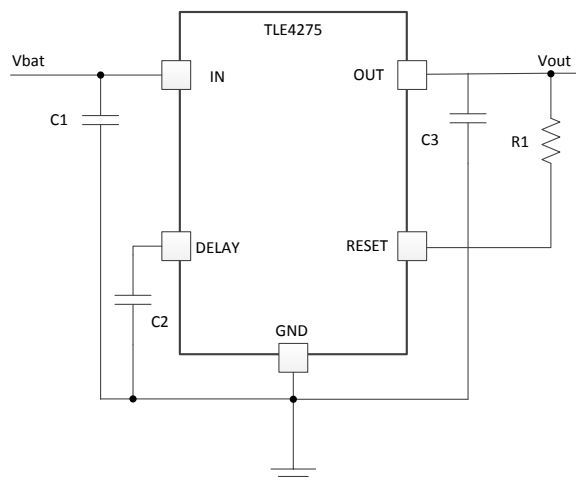

The input capacitor,  $C_{IN}$ , compensates for line fluctuation. Using a resistor of approximately 1  $\Omega$  in series with  $C_{IN}$  dampens the oscillation of input inductance and input capacitance. The output capacitor,  $C_{OUT}$ , stabilizes the regulation circuit. The specification for stability is at  $C_{OUT} \geq 22$   $\mu$ F and  $ESR \leq 5$   $\Omega$ , within the operating temperature range. Stability for electrolytic capacitors specifically is at  $C_{OUT} \geq 68$   $\mu$ F within the operating temperature range. See the application report on low-temperature stability, [SLVA501](#), for further details.

The control amplifier compares a reference voltage to a voltage that is proportional to the output voltage and drives the base of the series transistor through a buffer. Saturation control as a function of the load current prevents any oversaturation of the power element. The device also incorporates a number of internal circuits for protection against: *overload*, *overtemperature*, and *reverse polarity*.

#### Device Information<sup>(1)</sup>

PART NUMBER	PACKAGE	BODY SIZE (NOM)
TLE4275-Q1	DDPAK/TO-263 (5)	10.16 mm $\times$ 8.42 mm
	TO-252 (5)	6.10 mm $\times$ 6.60 mm
	HTSSOP (20)	6.50 mm $\times$ 4.40 mm

(1) For all available packages, see the orderable addendum at the end of the data sheet.



## Table of Contents

<b>1</b>	<b>Features</b> .....	<b>1</b>	9.2	Functional Block Diagram .....	<b>11</b>
<b>2</b>	<b>Applications</b> .....	<b>1</b>	9.3	Feature Description .....	<b>12</b>
<b>3</b>	<b>Description</b> .....	<b>1</b>	9.4	Device Functional Modes .....	<b>12</b>
<b>4</b>	<b>Typical Application</b> .....	<b>1</b>	<b>10</b>	<b>Application and Implementation</b> .....	<b>13</b>
<b>5</b>	<b>Revision History</b> .....	<b>2</b>	10.1	Application Information .....	<b>13</b>
<b>6</b>	<b>Pin Configuration and Functions</b> .....	<b>3</b>	10.2	Typical Application .....	<b>13</b>
<b>7</b>	<b>Specifications</b> .....	<b>4</b>	<b>11</b>	<b>Power Supply Recommendations</b> .....	<b>15</b>
7.1	Absolute Maximum Ratings .....	<b>4</b>	<b>12</b>	<b>Layout</b> .....	<b>15</b>
7.2	ESD Ratings .....	<b>4</b>	12.1	Layout Guidelines .....	<b>15</b>
7.3	Recommended Operating Conditions .....	<b>4</b>	12.2	Layout Example .....	<b>15</b>
7.4	Thermal Information .....	<b>4</b>	<b>13</b>	<b>Device and Documentation Support</b> .....	<b>16</b>
7.5	Electrical Characteristics .....	<b>5</b>	13.1	Documentation Support .....	<b>16</b>
7.6	Switching Characteristics .....	<b>5</b>	13.2	Trademarks .....	<b>16</b>
7.7	Typical Characteristics .....	<b>7</b>	13.3	Electrostatic Discharge Caution .....	<b>16</b>
<b>8</b>	<b>Parameter Measurement Information</b> .....	<b>10</b>	13.4	Glossary .....	<b>16</b>
<b>9</b>	<b>Detailed Description</b> .....	<b>11</b>	<b>14</b>	<b>Mechanical, Packaging, and Orderable Information</b> .....	<b>16</b>
9.1	Overview .....	<b>11</b>			

## 5 Revision History

### Changes from Revision H (March 2013) to Revision I

**Page**

- Added *Applications*, *Pin Configuration and Functions* section, *Handling Rating* table, *Feature Description* section, *Device Functional Modes*, *Application and Implementation* section, *Power Supply Recommendations* section, *Layout* section, *Device and Documentation Support* section, and *Mechanical, Packaging, and Orderable Information* section ..... **1**
- Changed KTT values in *Thermal Information* table ..... **4**

### Changes from Revision G (January 2013) to Revision H

**Page**

- Deleted row for  $\theta_{JA}$  from *Absolute Maximum Ratings* table ..... **4**

### Changes from Revision F (May 2011) to Revision G

**Page**

- Updated *Pin Functions* table with PWP package pin information. .... **3**

## 6 Pin Configuration and Functions

**KTT Package**  
5-Pin DDPAK/TO-263  
Top View

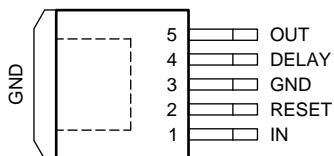

**KVU Package**  
5-Pin TO-252  
Top View

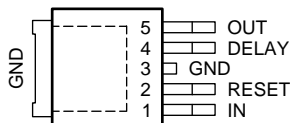

**PWP Package**  
20-Pin HTSSOP With Exposed Thermal Pad  
Top View

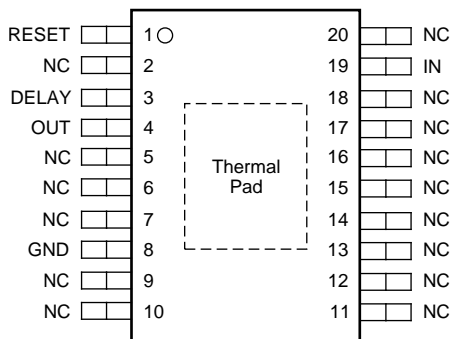

**Pin Functions**

NAME	PIN NO.			TYPE	DESCRIPTION
	KT	KVU	PWP		
DELAY	4	4	3	O	Reset delay. Connect to ground with a capacitor to set delay time.
GND	3	3	8	O	Ground. Internally connected to heatsink
IN	1	1	19	I	Input. Connect to ground as close to device as possible, through a ceramic capacitor.
NC	—	—	2, 5-7, 9-18, 20	—	Not connected
OUT	5	5	4	O	Output. Connect to ground with $\geq 22\text{-}\mu\text{F}$ capacitor, ESR $< 5\ \Omega$ at 10 kHz.
RESET	2	2	1	I	Reset output. Open-collector output

## 7 Specifications

### 7.1 Absolute Maximum Ratings<sup>(1)</sup>

over operating free-air temperature range (unless otherwise noted)

		MIN	MAX	UNIT	
V <sub>I</sub>	Input voltage range <sup>(2)</sup>	IN	-42	45	V
		DELAY	-0.3	7	
V <sub>O</sub>	Output voltage range	OUT	-1	16	V
		RESET	-0.3	25	
I <sub>I</sub>	Input current			±2	mA
I <sub>O</sub>	Output current			±5	mA
T <sub>J</sub>	Operating junction temperature	-40	150		°C
T <sub>stg</sub>	Storage temperature	-65	150		°C

- (1) Stresses beyond those listed under *Absolute Maximum Ratings* may cause permanent damage to the device. These are stress ratings only, and functional operation of the device at these or any other conditions beyond those indicated under *Recommended Operating Conditions* is not implied. Exposure to absolute-maximum-rated conditions for extended periods may affect device reliability.
- (2) All voltage values are with respect to the network ground terminal.

### 7.2 ESD Ratings

		VALUE	UNIT	
V <sub>(ESD)</sub>	Electrostatic discharge	Human body model (HBM), per AEC Q100-002 <sup>(1)</sup>	6000	V
		Machine model (MM) <sup>(2)</sup>	400	

- (1) AEC Q100-002 indicates HBM stressing is done in accordance with the ANSI/ESDA/JEDEC JS-001 specification.
- (2) MM ESD rating tested per JESD22-A115.

### 7.3 Recommended Operating Conditions

over operating free-air temperature range (unless otherwise noted)

		MIN	MAX	UNIT
V <sub>I</sub>	Input voltage	5.5	42	V
T <sub>J</sub>	Junction temperature	-40	150	°C

### 7.4 Thermal Information

THERMAL METRIC <sup>(1)</sup>		TLE4275-Q1			UNIT
		KTT	KVU	PWP	
		5 PINS	5 PINS	20 PINS	
R <sub>θJA</sub>	Junction-to-ambient thermal resistance	32.8	40.3	39.3	°C/W
R <sub>θJC(top)</sub>	Junction-to-case (top) thermal resistance	38.0	31.8	22.7	
R <sub>θJB</sub>	Junction-to-board thermal resistance	5.3	17.2	19.1	
ψ <sub>JT</sub>	Junction-to-top characterization parameter	6.3	2.8	0.6	
ψ <sub>JB</sub>	Junction-to-board characterization parameter	5.4	17.1	18.9	
R <sub>θJC(bot)</sub>	Junction-to-case (bottom) thermal resistance	0.8	0.7	1.5	

- (1) For more information about traditional and new thermal metrics, see the *IC Package Thermal Metrics* application report (SPRA953) .

## 7.5 Electrical Characteristics

over recommended operating free-air temperature range,  $V_I = 13.5\text{ V}$ ,  $T_J = -40^\circ\text{C}$  to  $150^\circ\text{C}$  (unless otherwise noted) (see [Figure 18](#))

PARAMETER		TEST CONDITIONS	MIN	TYP	MAX	UNIT
$V_O$	Output voltage	$I_O = 5\text{ mA}$ to $400\text{ mA}$ , $V_I = 6\text{ V}$ to $28\text{ V}$	4.9	5	5.1	V
		$I_O = 5\text{ mA}$ to $200\text{ mA}$ , $V_I = 6\text{ V}$ to $40\text{ V}$	4.9	5	5.1	
$I_O$	Output current limit		450	700	950	mA
$I_q$	Current consumption, $I_q = I_I - I_O$	$I_O = 1\text{ mA}$	$T_J = 25^\circ\text{C}$	150	200	$\mu\text{A}$
			$T_J \leq 85^\circ\text{C}$	150	220	
		$I_O = 250\text{ mA}$		5	10	mA
		$I_O = 400\text{ mA}$		12	22	
$V_{DO}$	Dropout voltage <sup>(1)</sup>	$I_O = 300\text{ mA}$ , $V_{do} = V_I - V_O$		250	500	mV
	Load regulation	$I_O = 5\text{ mA}$ to $400\text{ mA}$		15	30	mV
	Line regulation	$\Delta V_I = 8\text{ V}$ to $32\text{ V}$ , $I_O = 5\text{ mA}$	-15	5	15	mV
PSRR	Power-supply ripple rejection	$f_r = 100\text{ Hz}$ , $V_r = 0.5\text{ V}_{pp}$		60		dB
$\frac{\Delta V_O}{\Delta T}$	Temperature output-voltage drift			0.5		mV/K
$V_{O,rt}$	RESET switching threshold		4.5	4.65	4.8	V
$V_{ROL}$	RESET output low voltage	$R_{ext} \geq 5\text{ k}\Omega$ , $V_O > 1\text{ V}$		0.2	0.4	V
$I_{ROH}$	RESET output leakage current	$V_{ROH} = 5\text{ V}$		0	10	$\mu\text{A}$
$I_{D,c}$	RESET charging current	$V_D = 1\text{ V}$	3	5.5	9	$\mu\text{A}$
$V_{DU}$	RESET upper timing threshold		1.5	1.8	2.2	V
$V_{DRL}$	RESET lower timing threshold		0.2	0.4	0.7	V

(1) Measured when the output voltage  $V_O$  has dropped 100 mV from the nominal value obtained at  $V_I = 13.5\text{ V}$

## 7.6 Switching Characteristics

over operating free-air temperature range (unless otherwise noted) (see [Figure 1](#))

PARAMETER		TEST CONDITIONS	MIN	TYP	MAX	UNIT
$t_{rd}$	RESET delay time	$C_D = 47\text{ nF}$	10	16	22	ms
$t_{rr}$	RESET reaction time	$C_D = 47\text{ nF}$		0.5	2	$\mu\text{s}$

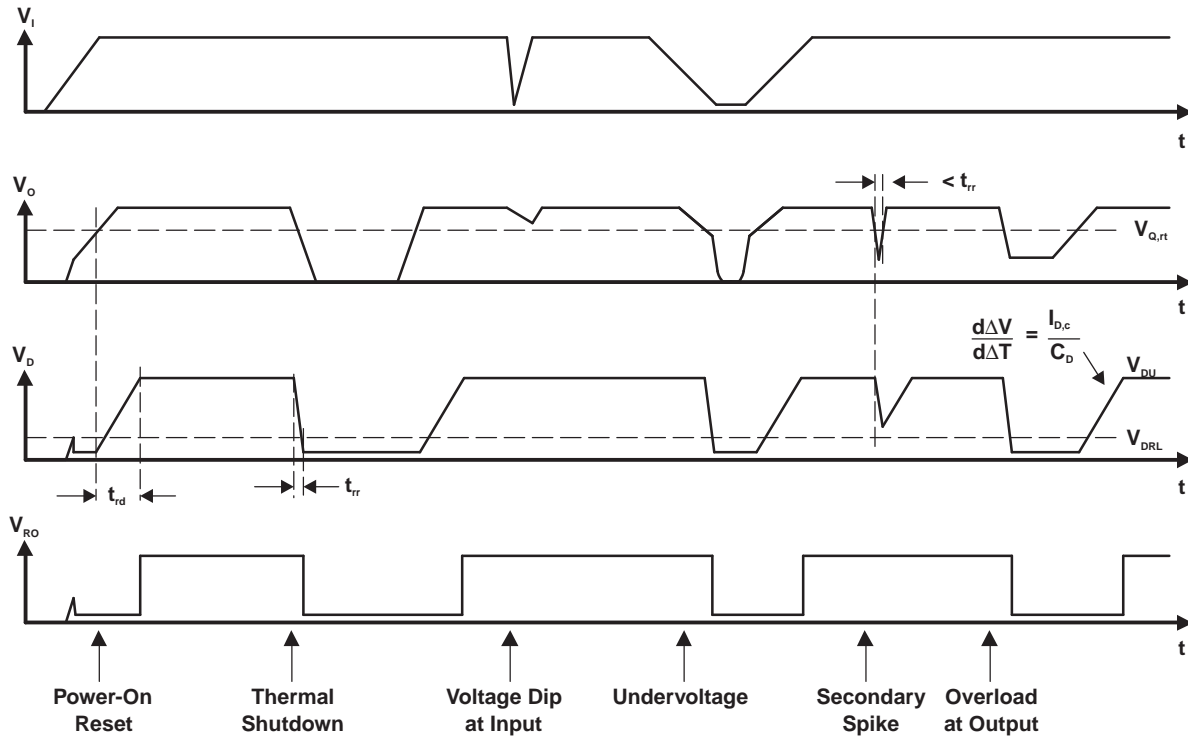

Figure 1. Reset Timing Diagram

## 7.7 Typical Characteristics

At  $T_A = 25^\circ\text{C}$

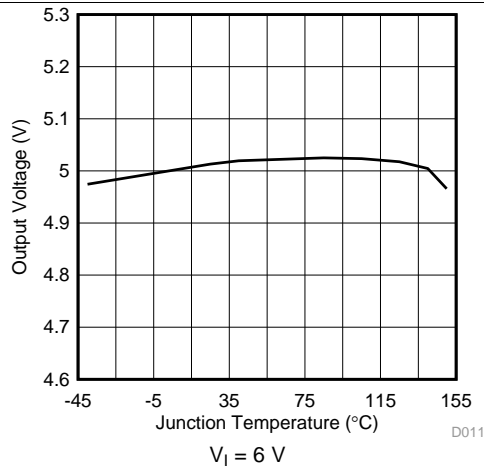

Figure 2. Output Voltage vs Junction Temperature

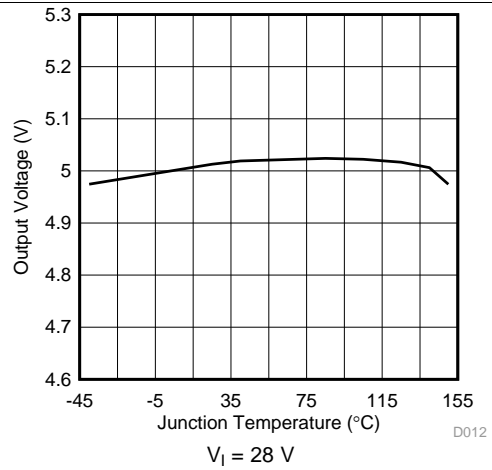

Figure 3. Output Voltage vs Junction Temperature

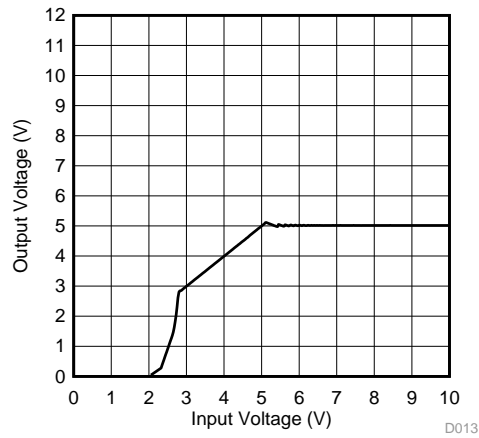

Figure 4. Output Voltage vs Input Voltage

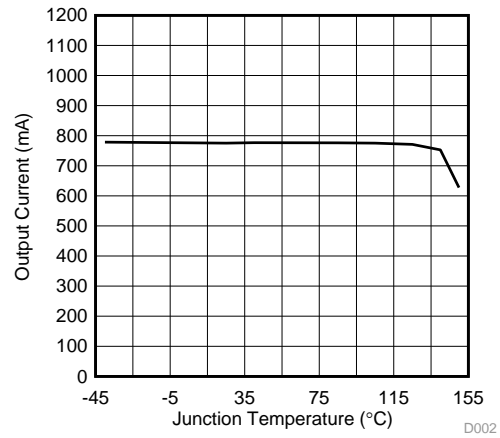

Figure 5. Output Current vs Junction Temperature

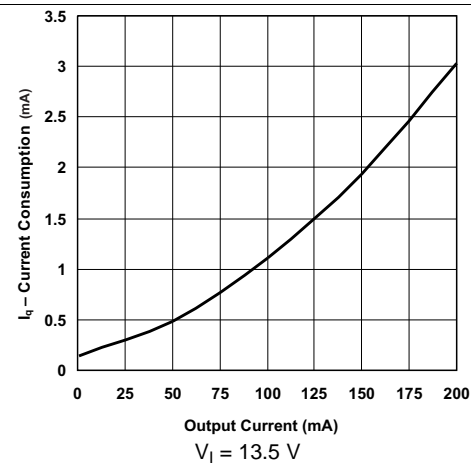

Figure 6. Current Consumption vs Output Current

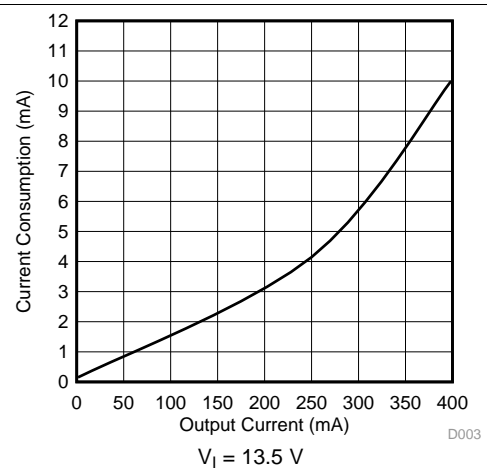

Figure 7. Current Consumption vs Output Current

Typical Characteristics (continued)

At  $T_A = 25^\circ\text{C}$

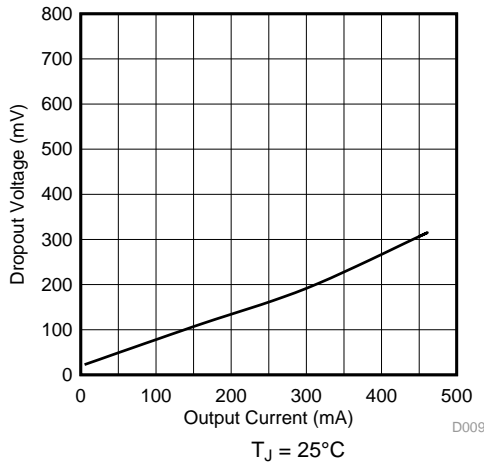

Figure 8. Dropout Voltage ( $V_{do}$ ) vs Output Current

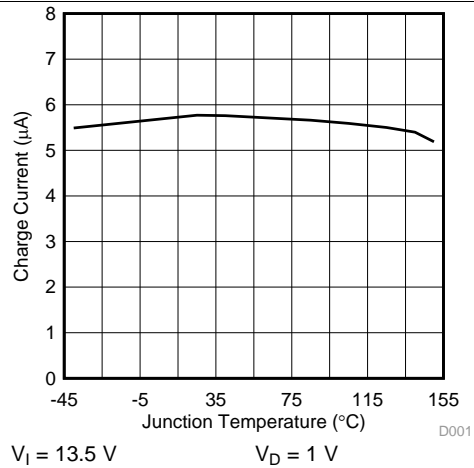

Figure 9. Charge Current ( $I_{b,c}$ ) vs Junction Temperature

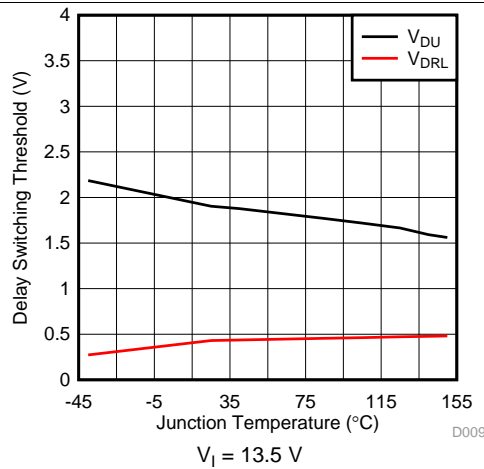

Figure 10. Delay Switching Threshold vs Junction Temperature

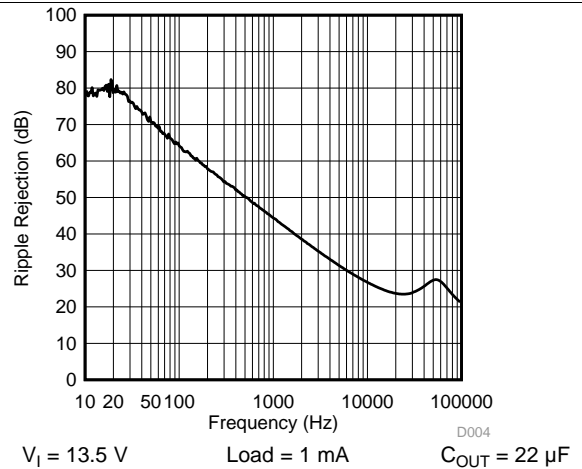

Figure 11. Power-Supply Ripple Rejection vs Frequency

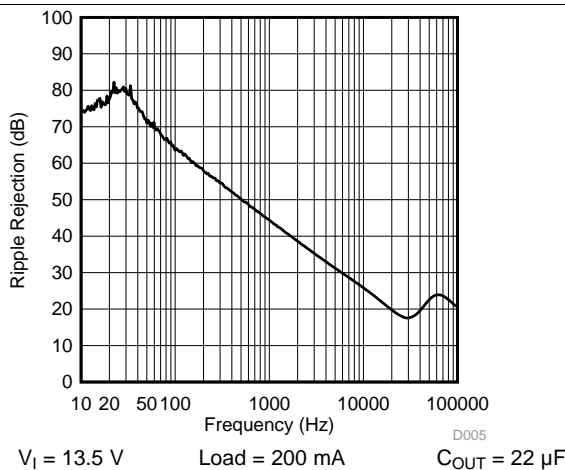

Figure 12. Power-Supply Ripple Rejection vs Frequency

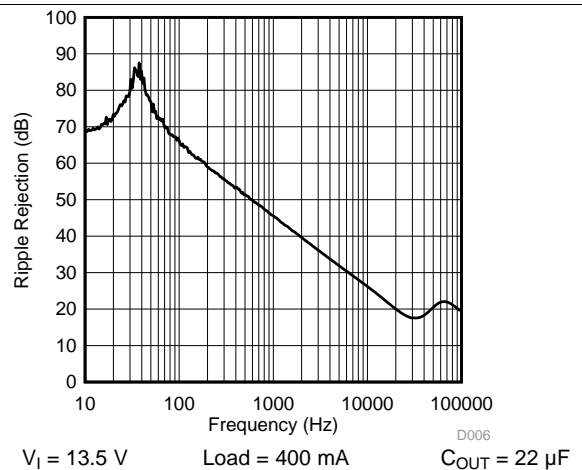

Figure 13. Power-Supply Ripple Rejection vs Frequency

Typical Characteristics (continued)

At  $T_A = 25^\circ\text{C}$

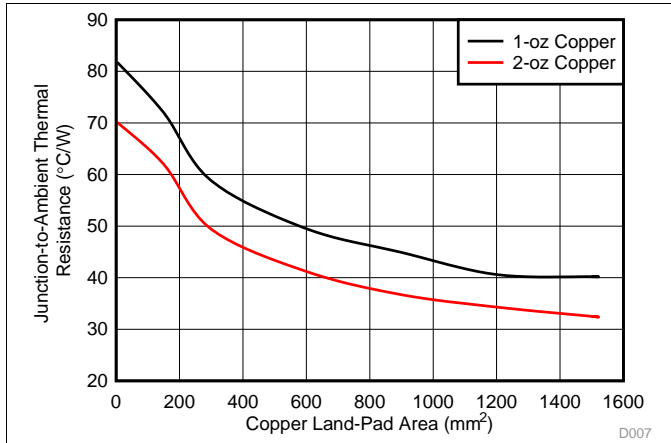

Figure 14. Thermal Resistance vs Copper Land Pad Area (JEDEC 51-3 Low-K Board)

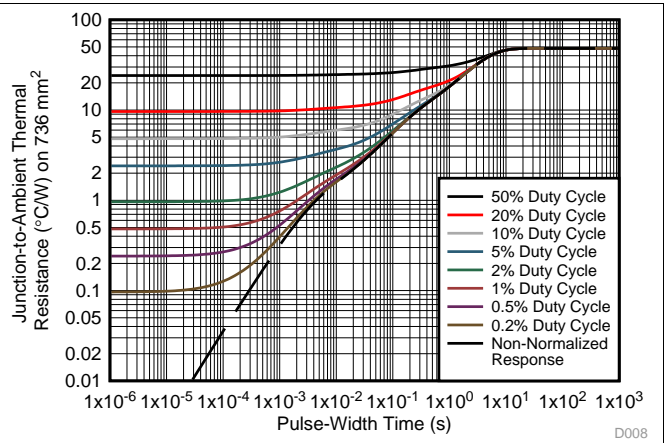

Figure 15. Thermal Resistance vs Pulse Width Time for Various Duty Cycles

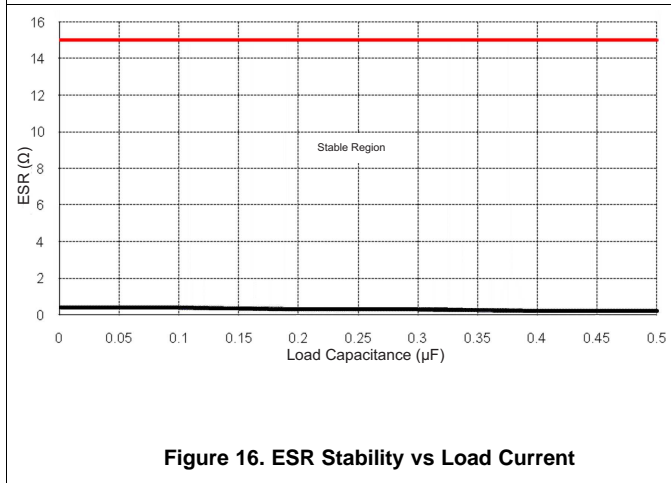

Figure 16. ESR Stability vs Load Current

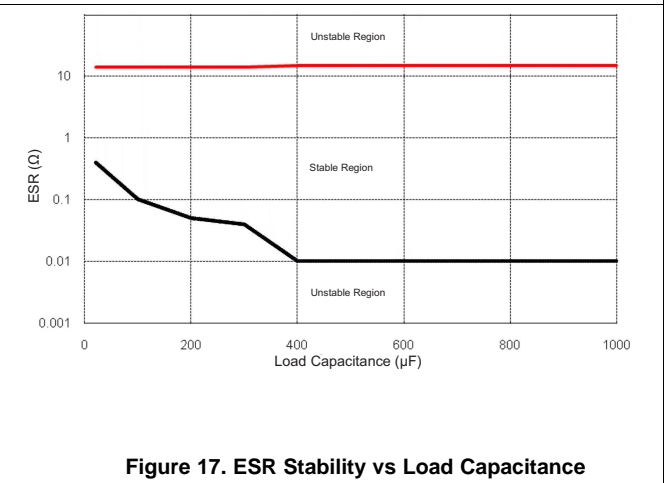

Figure 17. ESR Stability vs Load Capacitance

## 8 Parameter Measurement Information

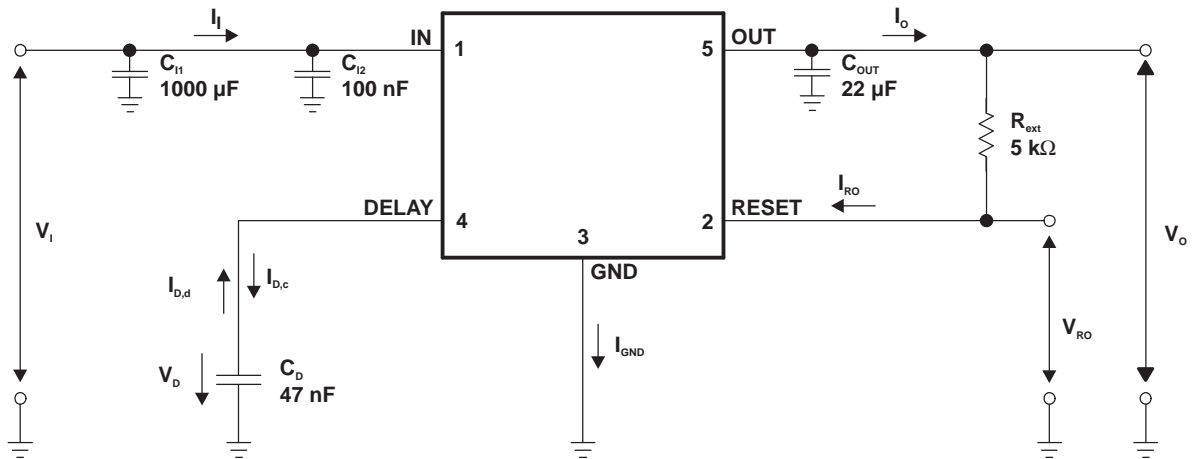

Figure 18. Test Circuit

## 9 Detailed Description

### 9.1 Overview

The TLE4275-Q1 device is a monolithic integrated low-dropout voltage regulator offered in a 5-pin TO package. The device regulates an input voltage up to 45 V to  $V_{OUT} = 5$  V (typical). The device can drive loads up to 450 mA and is short circuit proof. At over temperature, the incorporated temperature protection turns off the TLE4275-Q1 device. The device generates a reset signal for an output voltage,  $V_{OUT,rt}$  of 4.65 V (typical). By the use of an external delay capacitor, one can program the reset delay time.

### 9.2 Functional Block Diagram

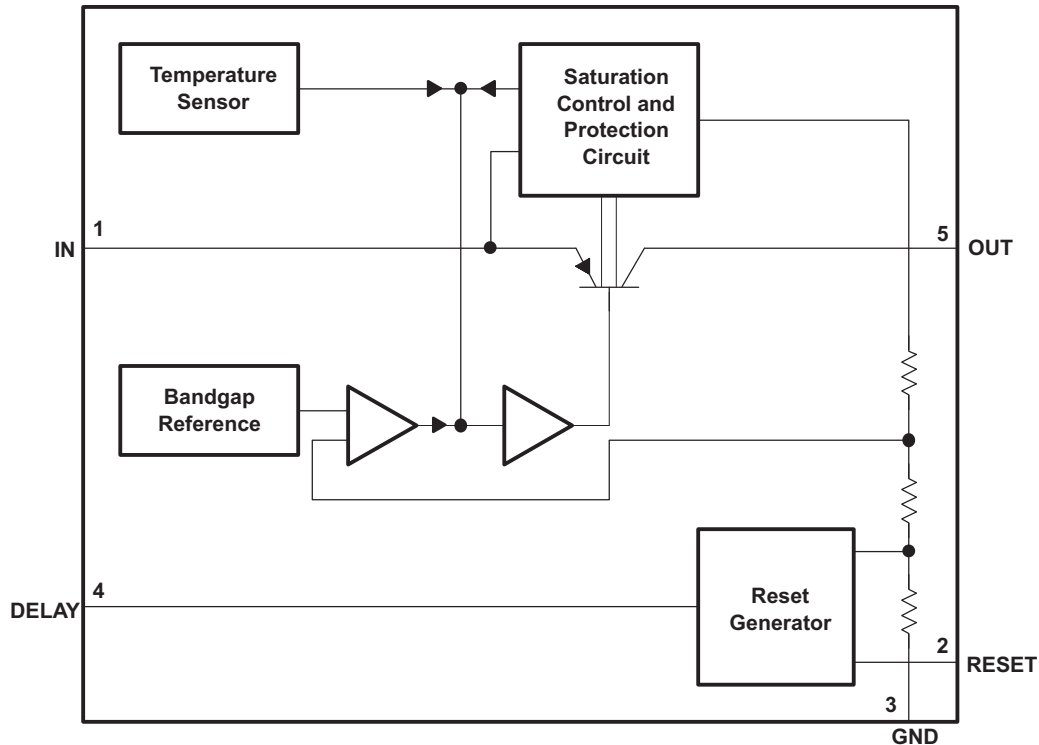

## 9.3 Feature Description

### 9.3.1 Regulated Output (OUT)

The OUT terminal is the regulated 5-V output. The output has current limitation. During initial power up, the regulator has a soft start incorporated to control the initial current through the pass element. In the event that the regulator drops out of regulation, the output tracks the input minus a drop based on the load current.

### 9.3.2 Power-On-Reset (RESET)

The power-on-reset is an output with an external pull up resistor to the regulated supply. The reset output remains low until the regulated  $V_O$  exceeds approximately 4.65 V and the power-on-reset delay has expired.

### 9.3.3 Reset Delay Timer (DELAY)

An external capacitor on this terminal sets the timer delay before the reset terminal is asserted high. The constant output current charges an external capacitor until the voltage exceeds a threshold to trip an internal comparator. The reset pulse delay time  $t_d$ , is defined with the charge time of an external capacitor DELAY.

$$t_d = \frac{C_{\text{delay}} \times V_{\text{DU}}}{I_{\text{D,c}}} \quad (1)$$

## 9.4 Device Functional Modes

### 9.4.1 Low-Voltage Tracking

At low input voltages, the regulator drops out of regulation and the output voltage tracks input minus a voltage based on the load current ( $I_O$ ) and switch resistance ( $R_{\text{SW}}$ ). This allows for a smaller input capacitor and can possibly eliminate the need of using a boost convertor during cold-crank conditions.

## 10 Application and Implementation

### NOTE

Information in the following applications sections is not part of the TI component specification, and TI does not warrant its accuracy or completeness. TI's customers are responsible for determining suitability of components for their purposes. Customers should validate and test their design implementation to confirm system functionality.

### 10.1 Application Information

Figure 19 shows typical application circuits for the TLE4275-Q1. Based on the end-application, different values of external components can be used. An application can require a larger output capacitor during fast load steps in order to prevent a reset from occurring. TI recommends a low-ESR ceramic capacitor with a dielectric of type X5R or X7R for better load transient response.

### 10.2 Typical Application

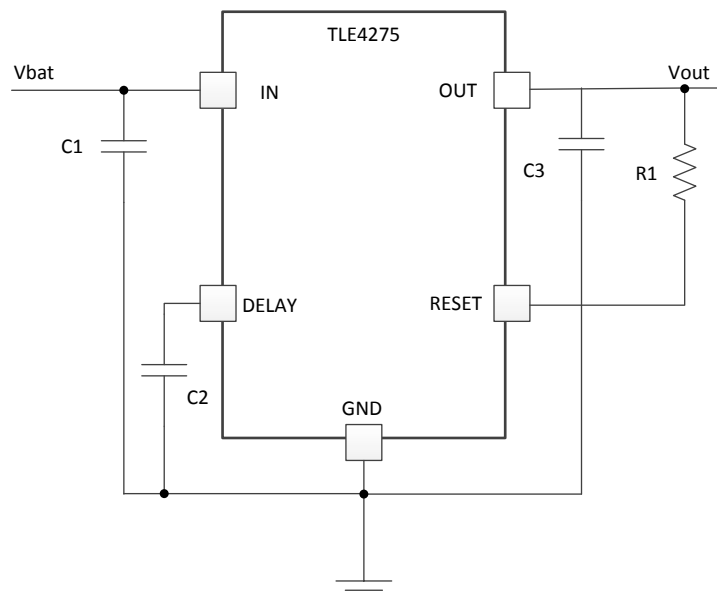

Figure 19. Typical Application Diagram

#### 10.2.1 Design Requirements

For this design example, use the parameters listed in Table 1.

Table 1. Design Parameters

DESIGN PARAMETER	EXAMPLE VALUE
Input voltage range	4 to 40 V
Output voltage	5 V
Output current rating	400 mA
Output capacitor range	10 to 500 $\mu$ F
Output capacitor ESR range	1 m $\Omega$ to 20 $\Omega$
DELAY capacitor range	100 pF to 500 nF

### 10.2.2 Detailed Design Procedure

To begin the design process, determine the following:

- Input voltage range
- Output voltage
- Output current rating
- Output capacitor
- Power-up reset delay time

#### 10.2.2.1 Power-Up Reset Capacitance

To calculate the power-up reset capacitance, use Equation 2.

$$t_d = \frac{C_{\text{delay}} \times V_{\text{DU}}}{I_{\text{D,c}}}$$

$$C_{\text{delay}} t_d = \frac{t_d \times I_{\text{D,c}}}{V_{\text{DU}}} = \frac{t_d \times 5.5 \times 10^{-6}}{1.8} \tag{2}$$

#### 10.2.2.2 Thermal Consideration

Calculate the power dissipated by the device according to Equation 3.

$$P_T = I_O \times (V_I - V_O) + V_I \times I_Q$$

where

- $P_T$  = Total power dissipation of the device.
- $I_O$  = output current
- $V_I$  = input voltage
- $V_O$  = output voltage

(3)

After determining the power dissipated by the device, calculate the junction temperature from the ambient temperature and the device thermal impedance.

$$T_J = T_A + R_{\theta JA} \times P_T$$

(4)

### 10.2.3 Application Curves

Load = 200 mA,  $C_{\text{in}} = 22 \mu\text{F}$ ,  $C_{\text{out}} = 10 \mu\text{F}$

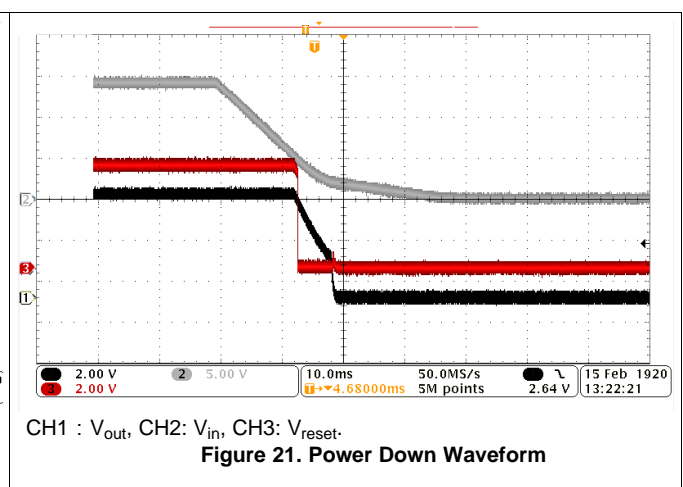
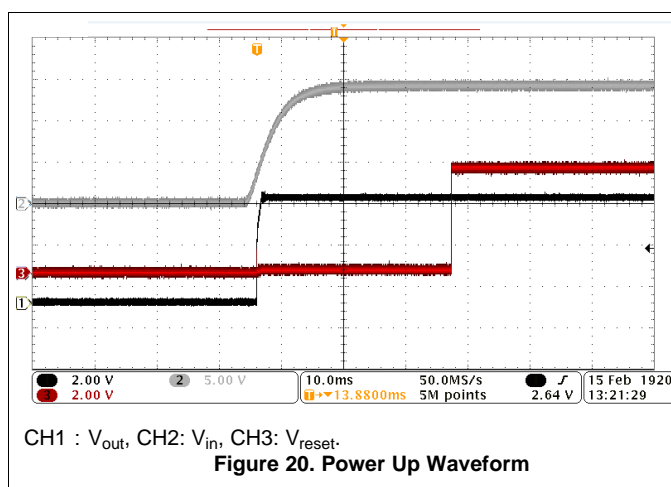

## 11 Power Supply Recommendations

The device is designed to operate from an input voltage supply range between 4 V and 40 V. This input supply must be well regulated. If the input supply is located more than a few inches from the TLE4275-Q1 device, an electrolytic capacitor with a value of 47  $\mu\text{F}$  and a ceramic bypass capacitor are recommended to add at the input.

## 12 Layout

### 12.1 Layout Guidelines

- Do not place any of the capacitors on the opposite side of the PCB from where the regulator is installed. The use of vias and long traces is strongly discouraged because of the negative impact on system performance. Vias and long traces can also cause instability.
- Equivalent series inductance (ESL) and ESR must be minimized in order to maximize performance and ensure stability. Every capacitor must be placed as close to the device as possible and on the same side of the PCB as the regulator.

### 12.2 Layout Example

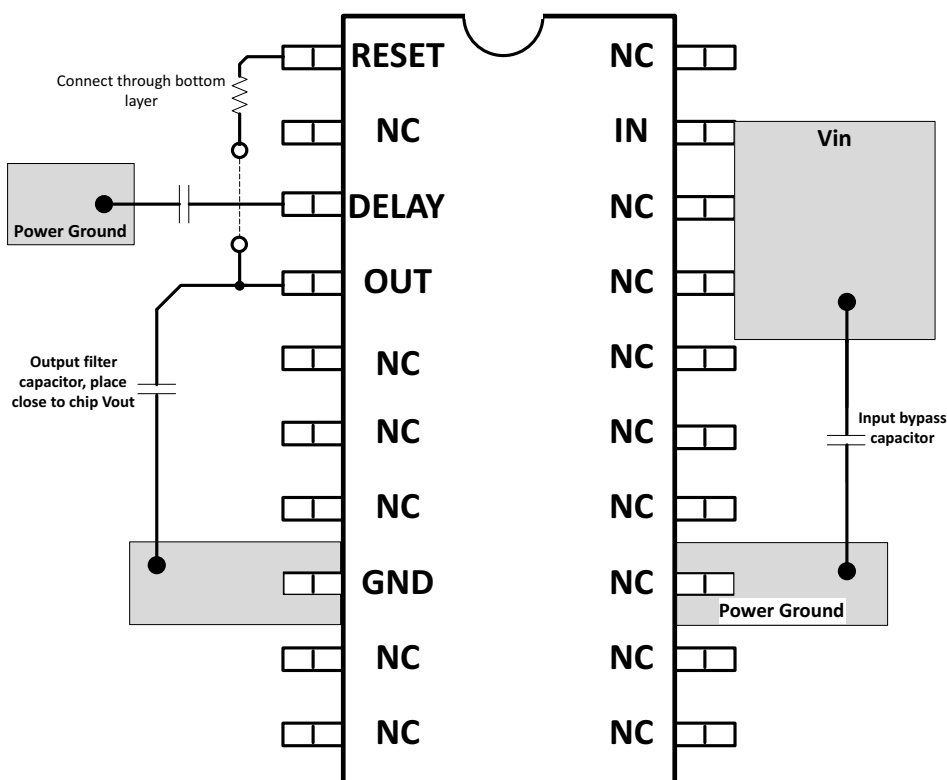

Figure 22. TLE4275-Q1 HTSSOP Layout Design Example

## 13 Device and Documentation Support

### 13.1 Documentation Support

#### 13.1.1 Related Documentation

For related documentation see the following:

*TLE4275-Q1 Low Temperature Stability*, [SLVA501](#)

### 13.2 Trademarks

All trademarks are the property of their respective owners.

### 13.3 Electrostatic Discharge Caution



These devices have limited built-in ESD protection. The leads should be shorted together or the device placed in conductive foam during storage or handling to prevent electrostatic damage to the MOS gates.

### 13.4 Glossary

[SLYZ022](#) — *TI Glossary*.

This glossary lists and explains terms, acronyms, and definitions.

## 14 Mechanical, Packaging, and Orderable Information

The following pages include mechanical, packaging, and orderable information. This information is the most current data available for the designated devices. This data is subject to change without notice and revision of this document. For browser-based versions of this data sheet, refer to the left-hand navigation.

**PACKAGING INFORMATION**

Orderable Device	Status (1)	Package Type	Package Drawing	Pins	Package Qty	Eco Plan (2)	Lead finish/ Ball material (6)	MSL Peak Temp (3)	Op Temp (°C)	Device Marking (4/5)	Samples
TLE4275QKTRRQ1	ACTIVE	DDPAK/ TO-263	KTT	5	500	RoHS & Green	SN	Level-3-245C-168 HR	-40 to 125	TLE4275Q	<a href="#">Samples</a>
TLE4275QKVURQ1	ACTIVE	TO-252	KVU	5	2500	RoHS & Green	SN	Level-3-260C-168 HR	-40 to 125	TLE4275Q	<a href="#">Samples</a>
TLE4275QPWPRQ1	ACTIVE	HTSSOP	PWP	20	2000	RoHS & Green	NIPDAU	Level-3-260C-168 HR	-40 to 125	TLE4275Q	<a href="#">Samples</a>

(1) The marketing status values are defined as follows:

**ACTIVE:** Product device recommended for new designs.

**LIFEBUY:** TI has announced that the device will be discontinued, and a lifetime-buy period is in effect.

**NRND:** Not recommended for new designs. Device is in production to support existing customers, but TI does not recommend using this part in a new design.

**PREVIEW:** Device has been announced but is not in production. Samples may or may not be available.

**OBSOLETE:** TI has discontinued the production of the device.

(2) **RoHS:** TI defines "RoHS" to mean semiconductor products that are compliant with the current EU RoHS requirements for all 10 RoHS substances, including the requirement that RoHS substance do not exceed 0.1% by weight in homogeneous materials. Where designed to be soldered at high temperatures, "RoHS" products are suitable for use in specified lead-free processes. TI may reference these types of products as "Pb-Free".

**RoHS Exempt:** TI defines "RoHS Exempt" to mean products that contain lead but are compliant with EU RoHS pursuant to a specific EU RoHS exemption.

**Green:** TI defines "Green" to mean the content of Chlorine (Cl) and Bromine (Br) based flame retardants meet JS709B low halogen requirements of <=1000ppm threshold. Antimony trioxide based flame retardants must also meet the <=1000ppm threshold requirement.

(3) MSL, Peak Temp. - The Moisture Sensitivity Level rating according to the JEDEC industry standard classifications, and peak solder temperature.

(4) There may be additional marking, which relates to the logo, the lot trace code information, or the environmental category on the device.

(5) Multiple Device Markings will be inside parentheses. Only one Device Marking contained in parentheses and separated by a "~" will appear on a device. If a line is indented then it is a continuation of the previous line and the two combined represent the entire Device Marking for that device.

(6) Lead finish/Ball material - Orderable Devices may have multiple material finish options. Finish options are separated by a vertical ruled line. Lead finish/Ball material values may wrap to two lines if the finish value exceeds the maximum column width.

**Important Information and Disclaimer:**The information provided on this page represents TI's knowledge and belief as of the date that it is provided. TI bases its knowledge and belief on information provided by third parties, and makes no representation or warranty as to the accuracy of such information. Efforts are underway to better integrate information from third parties. TI has taken and continues to take reasonable steps to provide representative and accurate information but may not have conducted destructive testing or chemical analysis on incoming materials and chemicals. TI and TI suppliers consider certain information to be proprietary, and thus CAS numbers and other limited information may not be available for release.

In no event shall TI's liability arising out of such information exceed the total purchase price of the TI part(s) at issue in this document sold by TI to Customer on an annual basis.

## TAPE AND REEL INFORMATION



### QUADRANT ASSIGNMENTS FOR PIN 1 ORIENTATION IN TAPE



\*All dimensions are nominal

Device	Package Type	Package Drawing	Pins	SPQ	Reel Diameter (mm)	Reel Width W1 (mm)	A0 (mm)	B0 (mm)	K0 (mm)	P1 (mm)	W (mm)	Pin1 Quadrant
TLE4275QKTTRQ1	DDPAK/ TO-263	KTT	5	500	330.0	24.4	10.6	15.8	4.9	16.0	24.0	Q2
TLE4275QKVURQ1	TO-252	KVU	5	2500	330.0	16.4	6.9	10.5	2.7	8.0	16.0	Q2
TLE4275QPWPRQ1	HTSSOP	PWP	20	2000	330.0	16.4	6.95	7.1	1.6	8.0	16.0	Q1

## TAPE AND REEL BOX DIMENSIONS



\*All dimensions are nominal

Device	Package Type	Package Drawing	Pins	SPQ	Length (mm)	Width (mm)	Height (mm)
TLE4275QKTTRQ1	DDPAK/TO-263	KTT	5	500	340.0	340.0	38.0
TLE4275QKVURQ1	TO-252	KVU	5	2500	340.0	340.0	38.0
TLE4275QPWPRQ1	HTSSOP	PWP	20	2000	350.0	350.0	43.0



KVU (R-PSFM-G5)

PLASTIC FLANGE MOUNT PACKAGE

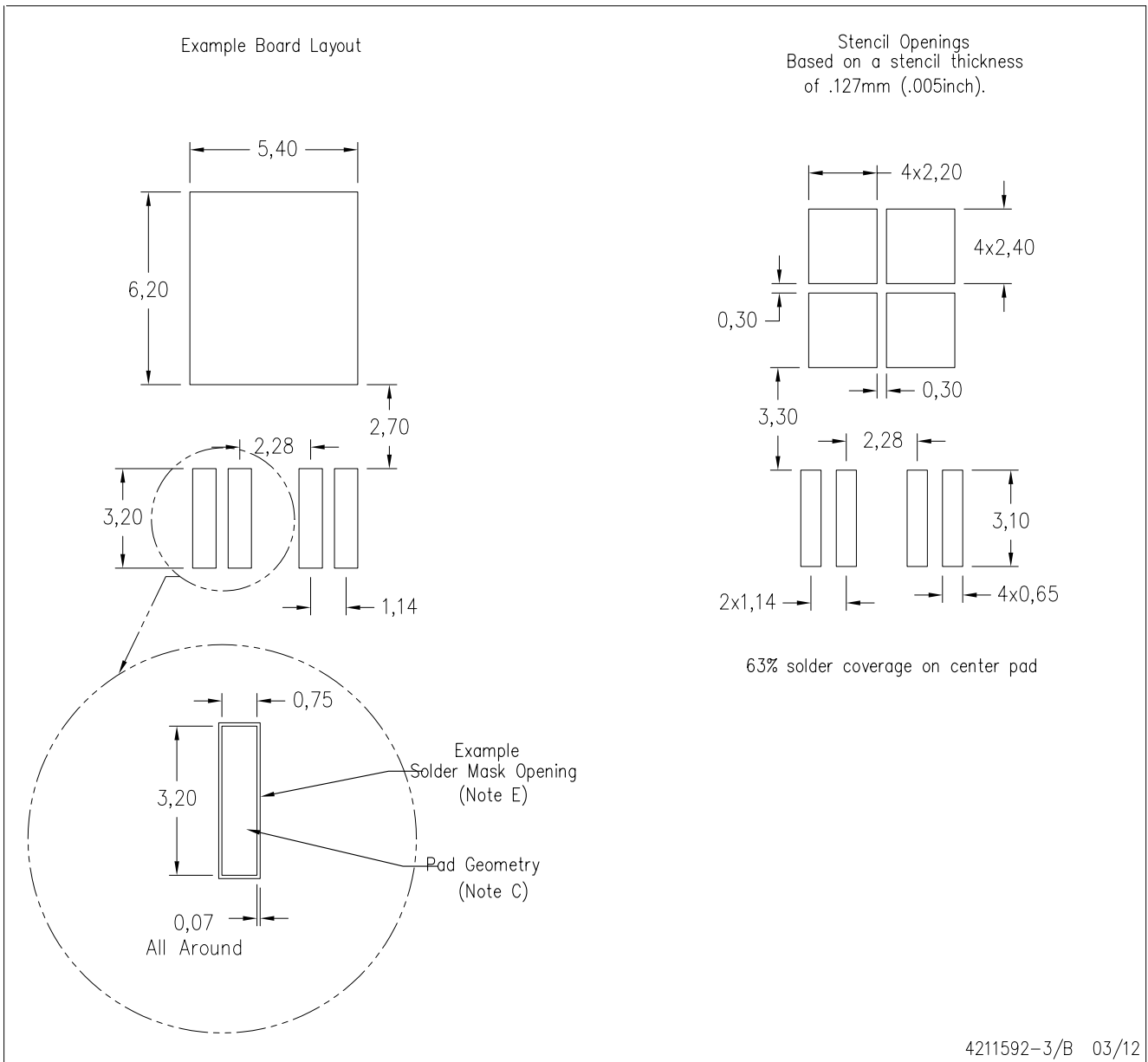

- NOTES:
- A. All linear dimensions are in millimeters.
  - B. This drawing is subject to change without notice.
  - C. Publication IPC-SM-782 is an alternate information source for PCB land pattern designs.
  - D. Laser cutting apertures with trapezoidal walls and also rounding corners will offer better paste release. Customers should contact their board assembly site for stencil design recommendations. Refer to IPC-7525 for other stencil recommendations.
  - E. Customers should contact their board fabrication site for recommended solder mask tolerances and via tenting recommendations for vias placed in thermal pad.

# MECHANICAL DATA

PWP (R-PDSO-G20)

PowerPAD™ PLASTIC SMALL OUTLINE

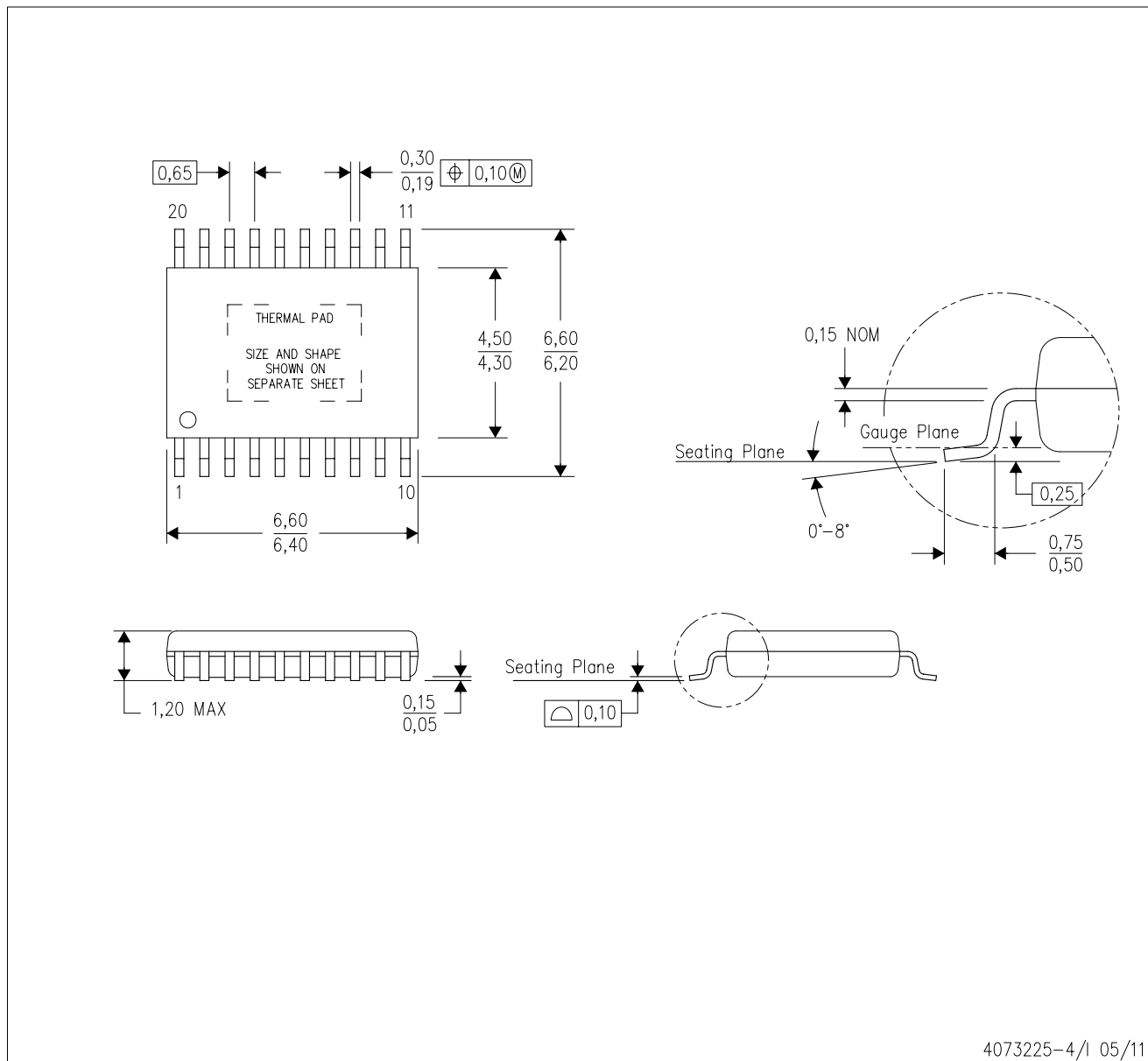

4073225-4/1 05/11

- NOTES:
- All linear dimensions are in millimeters.
  - This drawing is subject to change without notice.
  - Body dimensions do not include mold flash or protrusions. Mold flash and protrusion shall not exceed 0.15 per side.
  - This package is designed to be soldered to a thermal pad on the board. Refer to Technical Brief, PowerPad Thermally Enhanced Package, Texas Instruments Literature No. SLMA002 for information regarding recommended board layout. This document is available at [www.ti.com](http://www.ti.com) <<http://www.ti.com>>.
  - See the additional figure in the Product Data Sheet for details regarding the exposed thermal pad features and dimensions.
  - Falls within JEDEC MO-153

PowerPAD is a trademark of Texas Instruments.

# THERMAL PAD MECHANICAL DATA

## PWP (R-PDSO-G20) PowerPAD™ SMALL PLASTIC OUTLINE

### THERMAL INFORMATION

This PowerPAD™ package incorporates an exposed thermal pad that is designed to be attached to a printed circuit board (PCB). The thermal pad must be soldered directly to the PCB. After soldering, the PCB can be used as a heatsink. In addition, through the use of thermal vias, the thermal pad can be attached directly to the appropriate copper plane shown in the electrical schematic for the device, or alternatively, can be attached to a special heatsink structure designed into the PCB. This design optimizes the heat transfer from the integrated circuit (IC).

For additional information on the PowerPAD package and how to take advantage of its heat dissipating abilities, refer to Technical Brief, PowerPAD Thermally Enhanced Package, Texas Instruments Literature No. SLMA002 and Application Brief, PowerPAD Made Easy, Texas Instruments Literature No. SLMA004. Both documents are available at [www.ti.com](http://www.ti.com).

The exposed thermal pad dimensions for this package are shown in the following illustration.

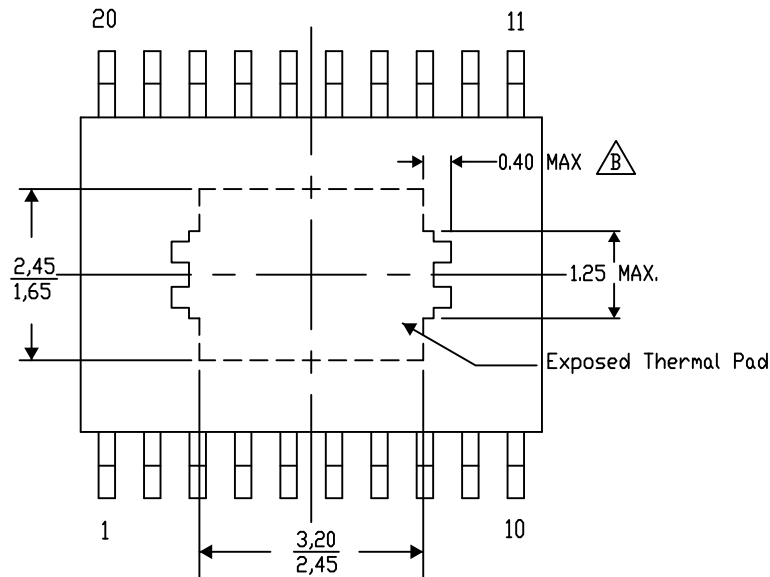

Top View

Exposed Thermal Pad Dimensions

4206332-18/AO 01/16

NOTE: A. All linear dimensions are in millimeters

$\triangle B$  Exposed tie strap features may not be present.

PowerPAD is a trademark of Texas Instruments

PWP (R-PDSO-G20)

PowerPAD™ PLASTIC SMALL OUTLINE

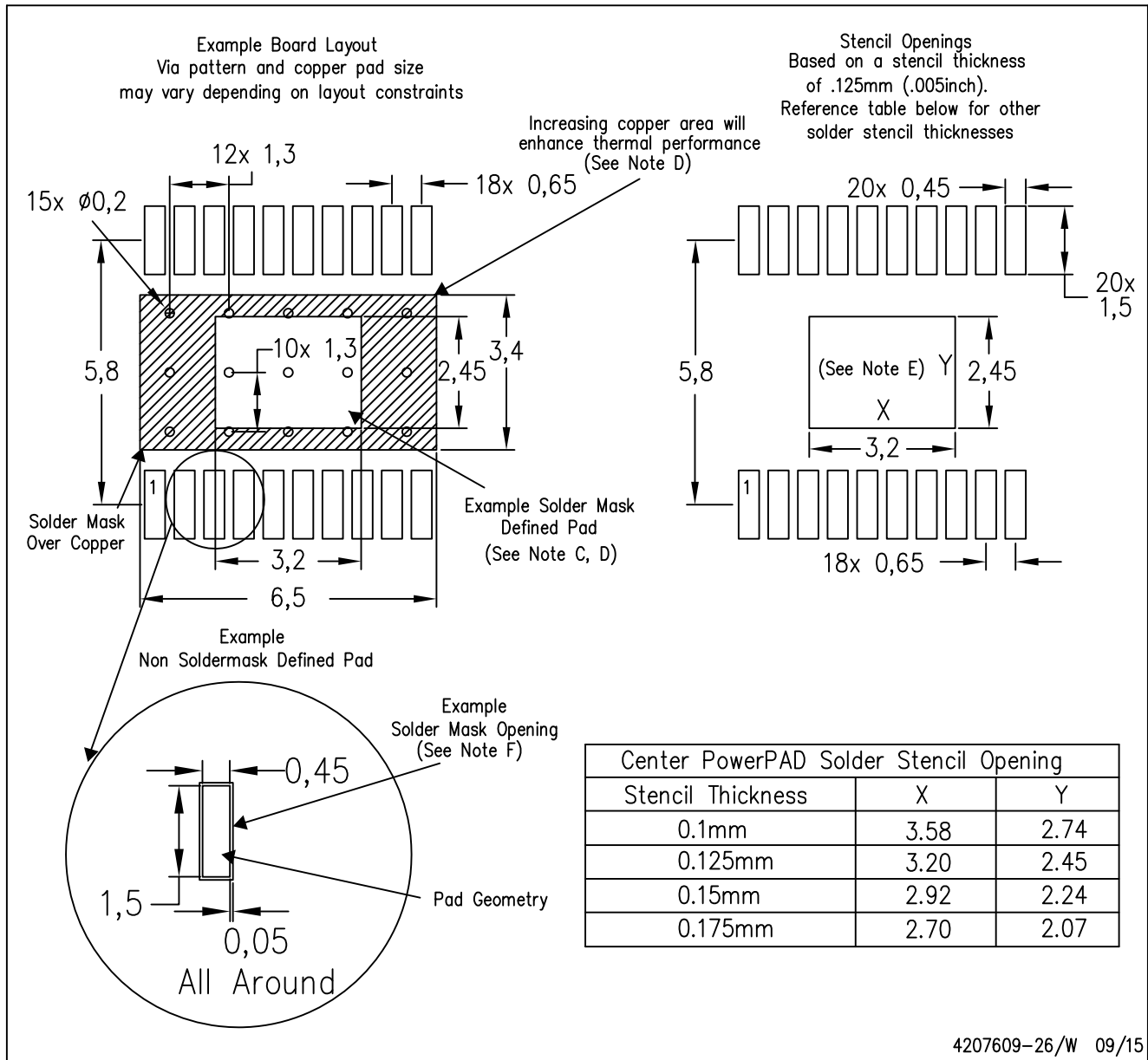

- NOTES:
- All linear dimensions are in millimeters.
  - This drawing is subject to change without notice.
  - Customers should place a note on the circuit board fabrication drawing not to alter the center solder mask defined pad.
  - This package is designed to be soldered to a thermal pad on the board. Refer to Technical Brief, PowerPad Thermally Enhanced Package, Texas Instruments Literature No. SLMA002, SLMA004, and also the Product Data Sheets for specific thermal information, via requirements, and recommended board layout. These documents are available at [www.ti.com](http://www.ti.com) <<http://www.ti.com>>. Publication IPC-7351 is recommended for alternate designs.
  - Laser cutting apertures with trapezoidal walls and also rounding corners will offer better paste release. Customers should contact their board assembly site for stencil design recommendations. Example stencil design based on a 50% volumetric metal load solder paste. Refer to IPC-7525 for other stencil recommendations.
  - Customers should contact their board fabrication site for solder mask tolerances between and around signal pads.

KTT (R-PSFM-G5)

PLASTIC FLANGE-MOUNT PACKAGE



4200577-4/G 01/13

KTT (R-PSFM-G5)

PLASTIC FLANGE-MOUNT PACKAGE

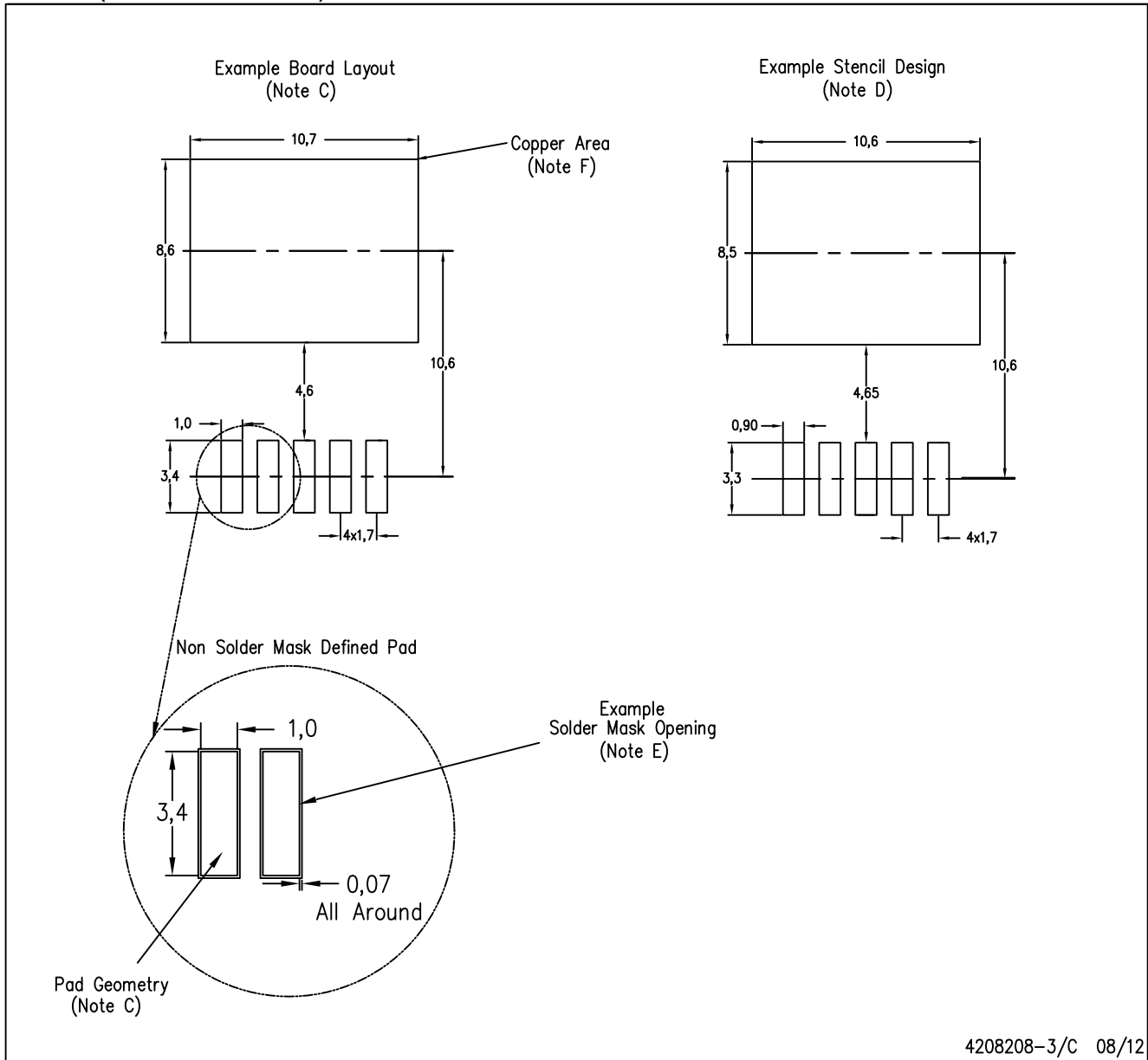

4208208-3/C 08/12

- NOTES:
- All linear dimensions are in millimeters.
  - This drawing is subject to change without notice.
  - Publication IPC-SM-782 is recommended for alternate designs.
  - Laser cutting apertures with trapezoidal walls and also rounding corners will offer better paste release. Customers should contact their board assembly site for stencil design recommendations. Refer to IPC-7525.
  - Customers should contact their board fabrication site for solder mask tolerances between and around signal pads.
  - This package is designed to be soldered to a thermal pad on the board. Refer to the Product Datasheet for specific thermal information, via requirements, and recommended thermal pad size. For thermal pad sizes larger than shown a solder mask defined pad is recommended in order to maintain the solderable pad geometry while increasing copper area.

## IMPORTANT NOTICE AND DISCLAIMER

TI PROVIDES TECHNICAL AND RELIABILITY DATA (INCLUDING DATASHEETS), DESIGN RESOURCES (INCLUDING REFERENCE DESIGNS), APPLICATION OR OTHER DESIGN ADVICE, WEB TOOLS, SAFETY INFORMATION, AND OTHER RESOURCES "AS IS" AND WITH ALL FAULTS, AND DISCLAIMS ALL WARRANTIES, EXPRESS AND IMPLIED, INCLUDING WITHOUT LIMITATION ANY IMPLIED WARRANTIES OF MERCHANTABILITY, FITNESS FOR A PARTICULAR PURPOSE OR NON-INFRINGEMENT OF THIRD PARTY INTELLECTUAL PROPERTY RIGHTS.

These resources are intended for skilled developers designing with TI products. You are solely responsible for (1) selecting the appropriate TI products for your application, (2) designing, validating and testing your application, and (3) ensuring your application meets applicable standards, and any other safety, security, or other requirements. These resources are subject to change without notice. TI grants you permission to use these resources only for development of an application that uses the TI products described in the resource. Other reproduction and display of these resources is prohibited. No license is granted to any other TI intellectual property right or to any third party intellectual property right. TI disclaims responsibility for, and you will fully indemnify TI and its representatives against, any claims, damages, costs, losses, and liabilities arising out of your use of these resources.

TI's products are provided subject to TI's Terms of Sale ([www.ti.com/legal/termsofsale.html](http://www.ti.com/legal/termsofsale.html)) or other applicable terms available either on [ti.com](http://ti.com) or provided in conjunction with such TI products. TI's provision of these resources does not expand or otherwise alter TI's applicable warranties or warranty disclaimers for TI products.

Mailing Address: Texas Instruments, Post Office Box 655303, Dallas, Texas 75265  
Copyright © 2020, Texas Instruments Incorporated