

TLV3691 0.9V 至 6.5V、毫微功耗比较器

1 特性

- 低静态电流: 75nA
- 宽电源:
 - 0.9V 至 6.5V
 - $\pm 0.45V$ 至 $\pm 3.25V$
- 微型封装: 双列扁平无脚封装 (DFN)-6 (1mm x 1mm), 5 引脚 SC70
- 输入共模范围扩展至两个电源轨以上 100mV
- 响应时间: 24 μ s
- 低输入偏移电压: $\pm 3mV$
- 推挽输出
- 工业温度范围: -40°C 至 125°C

2 应用

- 过压和欠压检测
- 窗口比较器
- 过流检测
- 零交叉检测
- 系统监控:
 - 智能电话
 - 平板电脑
 - 工业传感器
 - 便携式医疗设备

3 说明

此 TLV3691 提供宽电源电压范围、低至 150nA (最大值) 的静态电流和轨到轨输入。所有这些具有搭配行业标准的超小型封装, 使得这款器件成为便携式电子和工业系统中 低压和低功耗 应用的理想选择。

单通道、低功耗、宽电源和温度范围使得这款器件能够灵活处理从消费类到工业类的几乎全部应用。

TLV3691 采用 SC70-5 和 1mm x 1mm DFN-6 封装。这款器件可在 -40°C 至 125°C 的扩展工业温度范围内运行。

器件信息⁽¹⁾

器件型号	封装	封装尺寸 (标称值)
TLV3691	SC70 (5)	1.25mm x 2.00mm
	X2SON (6)	1.00mm x 1.00mm

(1) 要了解所有可用封装, 请参见数据表末尾的可订购产品附录。

毫微功耗运行

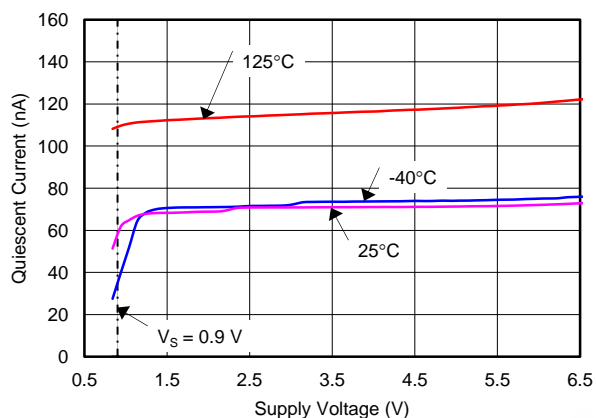

目录

1	特性	1	7.4	Device Functional Modes.....	12
2	应用	1	8	Application and Implementation	13
3	说明	1	8.1	Application Information.....	13
4	修订历史记录	2	8.2	Typical Application	16
5	Pin Configuration and Functions	3	9	Power Supply Recommendations	18
6	Specifications.....	4	10	Layout.....	19
6.1	Absolute Maximum Ratings	4	10.1	Layout Guidelines	19
6.2	ESD Ratings	4	10.2	Layout Example	19
6.3	Recommended Operating Conditions.....	4	11	器件和文档支持	20
6.4	Thermal Information	4	11.1	器件支持	20
6.5	Electrical Characteristics.....	5	11.2	文档支持	20
6.6	Switching Characteristics	6	11.3	社区资源	20
6.7	Typical Characteristics	7	11.4	商标	20
7	Detailed Description	12	11.5	静电放电警告	20
7.1	Overview	12	11.6	Glossary	21
7.2	Functional Block Diagram	12	12	机械、封装和可订购信息	21
7.3	Feature Description.....	12			

4 修订历史记录

注：之前版本的页码可能与当前版本有所不同。

Changes from Original (December 2013) to Revision A	Page
<ul style="list-style-type: none"> 已添加 ESD 额定值表，特性描述部分，器件功能模式，应用和实施部分，电源相关建议部分，布局部分，器件和文档支持部分以及机械、封装和可订购信息部分 	1

5 Pin Configuration and Functions

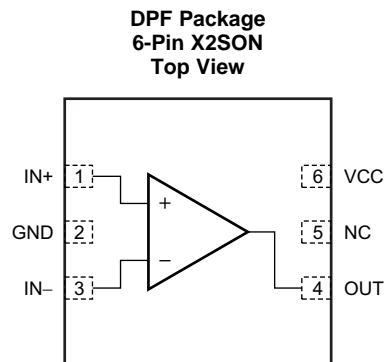
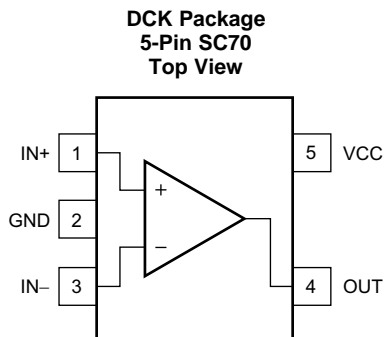

Pin Functions

NAME	PIN		I/O	DESCRIPTION
	X2SON	SC70		
GND	2	2	—	Ground
IN+	1	1	I	Noninverting input
IN-	3	3	I	Inverting input
NC	5	—	—	No internal connection
OUT	4	4	O	Output (push-pull)
VCC	6	5	I	Positive power supply

6 Specifications

6.1 Absolute Maximum Ratings

over operating free-air temperature range (unless otherwise noted) ⁽¹⁾

		MIN	MAX	UNIT
Supply voltage		7		V
Signal input terminals	Voltage ⁽²⁾	(V-) – 0.5	(V+) + 0.5	V
	Current ⁽²⁾	±10		mA
Output short circuit ⁽³⁾		Continuous		mA
Temperature	Operating, T _A	–55	150	°C
	Junction, T _J	150		
	Storage, T _{stg}	–65	150	

- (1) Stresses beyond those listed under *Absolute Maximum Ratings* may cause permanent damage to the device. These are stress ratings only, which do not imply functional operation of the device at these or any other conditions beyond those indicated under *Recommended Operating Conditions*. Exposure to absolute-maximum-rated conditions for extended periods may affect device reliability.
- (2) Input terminals are diode-clamped to the power-supply rails. Input signals that can swing more than 0.5 V beyond the supply rails should be current-limited to 10 mA or less.
- (3) Short-circuit to ground, one comparator per package.

6.2 ESD Ratings

		VALUE	UNIT
V _(ESD)	Electrostatic discharge	±2500	V
		±1000	

- (1) JEDEC document JEP155 states that 500-V HBM allows safe manufacturing with a standard ESD control process.
- (2) JEDEC document JEP157 states that 250-V CDM allows safe manufacturing with a standard ESD control process.

6.3 Recommended Operating Conditions

over operating free-air temperature range (unless otherwise noted)

	MIN	NOM	MAX	UNIT
Power supply voltage	0.9		6.5	V
Ambient Temperature, T _A	–40		125	°C

6.4 Thermal Information

THERMAL METRIC ⁽¹⁾	TLV3691		UNIT
	DCK (SC70)	DPF (X2SON)	
	5 PINS	6 PINS	
R _{θJA} Junction-to-ambient thermal resistance	297.4	252.4	°C/W
R _{θJctop} Junction-to-case (top) thermal resistance	109.3	93.9	°C/W
R _{θJB} Junction-to-board thermal resistance	74.4	192.8	°C/W
Ψ _{JT} Junction-to-top characterization parameter	3	3	°C/W
Ψ _{JB} Junction-to-board characterization parameter	73.6	203.8	°C/W
R _{θJcbot} Junction-to-case (bottom) thermal resistance	N/A	N/A	°C/W

- (1) For more information about traditional and new thermal metrics, see the *Semiconductor and IC Package Thermal Metrics* application report, [SPRA953](#).

6.5 Electrical Characteristics

At $T_A = 25^\circ\text{C}$, $V_S = 0.9\text{ V}$ to 6.5 V , $V_{CM} = V_S/2$ and $C_L = 15\text{ pF}$, unless otherwise noted.

PARAMETER		TEST CONDITIONS	MIN	TYP	MAX	UNIT
OFFSET VOLTAGE						
V_{OS}	Input offset voltage	$T_A = 25^\circ\text{C}$		± 3	± 15	mV
		$T_A = -40^\circ\text{C}$ to 125°C			± 22	mV
V_{HYS}	Hysteresis			17		mV
dV_{OS}/dT	Input offset voltage drift	$T_A = -40^\circ\text{C}$ to 125°C			± 70	$\mu\text{V}/^\circ\text{C}$
PSRR	Power-supply rejection ratio	$T_A = -40^\circ\text{C}$ to 125°C			2000	$\mu\text{V}/\text{V}$
INPUT VOLTAGE RANGE						
V_{CM}	Common-mode voltage range	$T_A = -40^\circ\text{C}$ to 125°C	$(V-) - 0.1$		$(V+) + 0.1$	V
	Hysteresis			± 17		mV
INPUT BIAS CURRENT						
I_B	Input bias current	$T_A = 25^\circ\text{C}$		30	100	pA
		$T_A = -40^\circ\text{C}$ to 125°C			20	nA
I_{OS}	Input offset current			8		pA
C_{LOAD}	Capacitive load drive		See Typical Characteristics			
OUTPUT						
V_{OH}	Voltage output swing from upper rail	$I_O = 2.5\text{ mA}$, input overdrive $\geq 50\text{ mV}$, $V_S = 6.5\text{ V}$		155	165	mV
		$I_O = 2.5\text{ mA}$, input overdrive $\geq 50\text{ mV}$, $V_S = 6.5\text{ V}$, $T_A = -40^\circ\text{C}$ to 125°C			220	mV
		$I_O \leq 100\ \mu\text{A}$, input overdrive $\geq 50\text{ mV}$, $V_S = 6.5\text{ V}$		6	10	mV
		$I_O \leq 100\ \mu\text{A}$, input overdrive $\geq 50\text{ mV}$, $V_S = 6.5\text{ V}$, $T_A = -40^\circ\text{C}$ to 125°C			20	mV
		$I_O \leq 100\ \mu\text{A}$, input overdrive $\geq 50\text{ mV}$, $V_S = 0.9\text{ V}$		70	75	mV
		$I_O \leq 100\ \mu\text{A}$, input overdrive $\geq 50\text{ mV}$, $V_S = 0.9\text{ V}$, $T_A = -40^\circ\text{C}$ to 125°C			80	mV
V_{OL}	Voltage output swing from lower rail	$I_O = 2.5\text{ mA}$, input overdrive $\geq 50\text{ mV}$, $V_S = 6.5\text{ V}$		155	165	mV
		$I_O = 2.5\text{ mA}$, input overdrive $\geq 50\text{ mV}$, $V_S = 6.5\text{ V}$, $T_A = -40^\circ\text{C}$ to 125°C			220	mV
		$I_O \leq 100\ \mu\text{A}$, input overdrive $\geq 50\text{ mV}$, $V_S = 6.5\text{ V}$		6	10	mV
		$I_O \leq 100\ \mu\text{A}$, input overdrive $\geq 50\text{ mV}$, $V_S = 6.5\text{ V}$, $T_A = -40^\circ\text{C}$ to 125°C			20	mV
		$I_O \leq 100\ \mu\text{A}$, input overdrive $\geq 50\text{ mV}$, $V_S = 0.9\text{ V}$		35	40	mV
		$I_O \leq 100\ \mu\text{A}$, input overdrive $\geq 50\text{ mV}$, $V_S = 0.9\text{ V}$, $T_A = -40^\circ\text{C}$ to 125°C			45	mV
I_{SC}	Short circuit sink current	$V_S = 6.5\text{ V}$, see Typical Characteristics		42		mA
	Short circuit source current	$V_S = 6.5\text{ V}$, see Typical Characteristics		35		mA

Electrical Characteristics (continued)

At $T_A = 25^\circ\text{C}$, $V_S = 0.9\text{ V}$ to 6.5 V , $V_{CM} = V_S/2$ and $C_L = 15\text{ pF}$, unless otherwise noted.

PARAMETER		TEST CONDITIONS	MIN	TYP	MAX	UNIT
POWER SUPPLY						
V_S	Specified voltage range		0.9		6.5	V
I_Q	Quiescent current (per channel)	$T_A = 25^\circ\text{C}$		75	150	nA
		$T_A = -40^\circ\text{C}$ to 125°C			200	nA
TEMPERATURE RANGE						
	Specified range		-40		125	$^\circ\text{C}$
	Operating range		-55		150	$^\circ\text{C}$
	Storage range		-65		150	$^\circ\text{C}$

6.6 Switching Characteristics

At $T_A = 25^\circ\text{C}$, $V_S = 0.9\text{ V}$ to 6.5 V , $V_{CM} = V_S/2$ and $C_L = 15\text{ pF}$, unless otherwise noted.

PARAMETER			TEST CONDITIONS	MIN	TYP	MAX	UNIT
t_{PHL}	Propagation delay time	High-to-low	$V_S = 6.5\text{ V}$, Input overdrive = 50 mV		32		μs
			$V_S = 0.9\text{ V}$, Input overdrive = 50 mV		45		
			$V_S = 6.5\text{ V}$, Input overdrive = 100 mV		24		
			$V_S = 0.9\text{ V}$, Input overdrive = 100 mV		35		
t_{PLH}		Low-to-high	$V_S = 6.5\text{ V}$, Input overdrive = 50 mV		32		
			$V_S = 0.9\text{ V}$, Input overdrive = 50 mV		40		
			$V_S = 6.5\text{ V}$, Input overdrive = 100 mV		24		
			$V_S = 0.9\text{ V}$, Input overdrive = 100 mV		28		
t_R	Rise time	Input overdrive = 100 mV					ns
t_F	Fall time	Input overdrive = 100 mV		330			

6.7 Typical Characteristics

At $T_A = 25^\circ\text{C}$, $V_S = 0.9\text{ V}$ to 6.5 V , and input overdrive = 100 mV , unless otherwise noted.

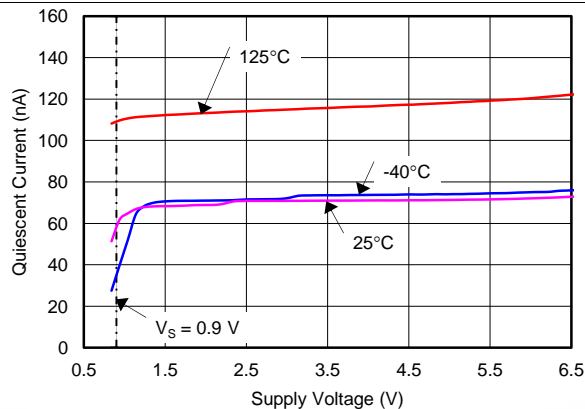

Figure 1. Quiescent Current vs Supply Voltage

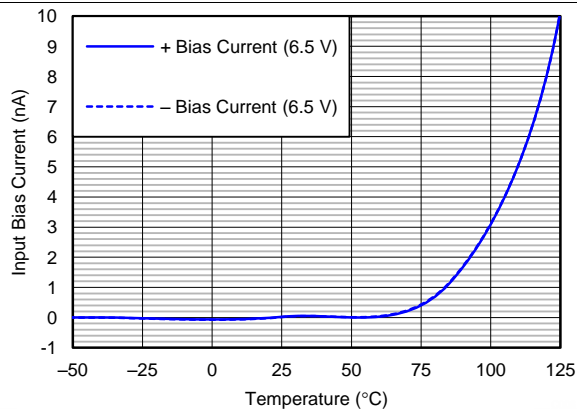

Figure 2. Input Bias Current vs Temperature

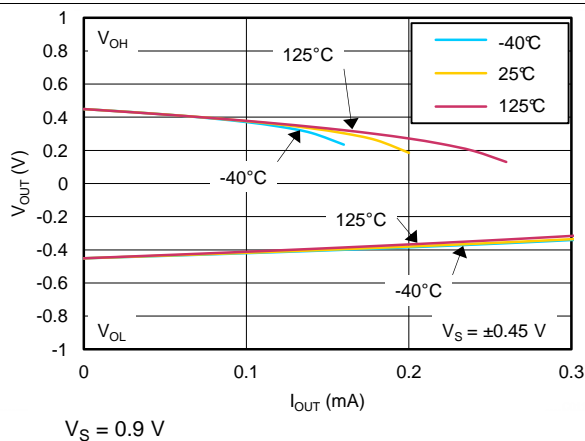

Figure 3. Output Voltage vs Output Current

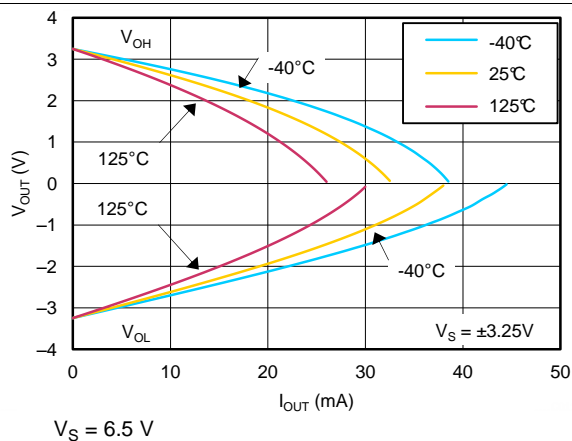

Figure 4. Output Voltage vs Output Current

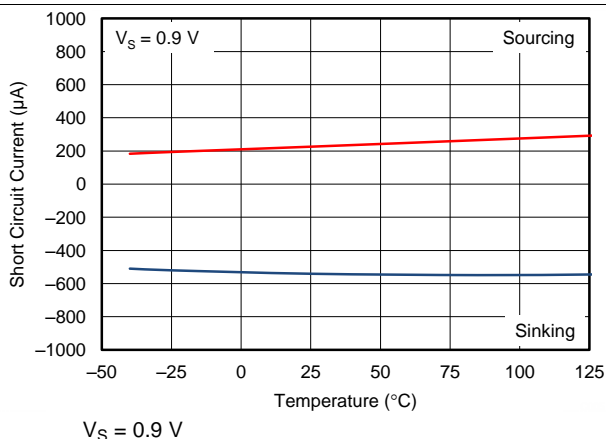

Figure 5. Short Circuit Current vs Temperature

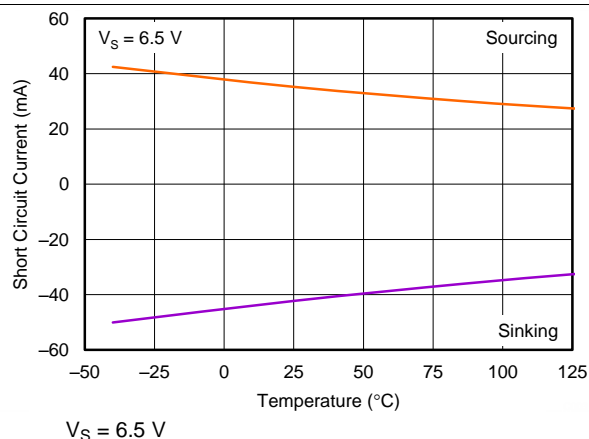
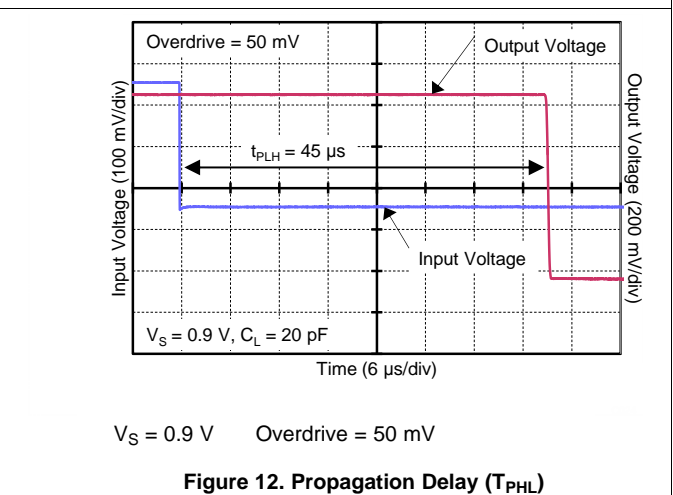
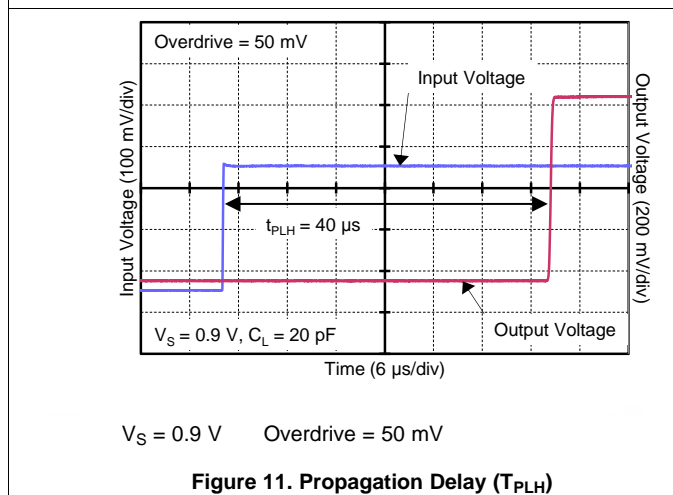
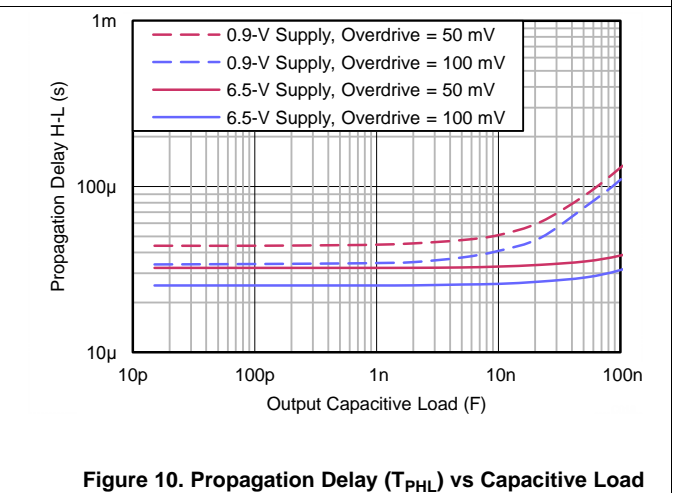
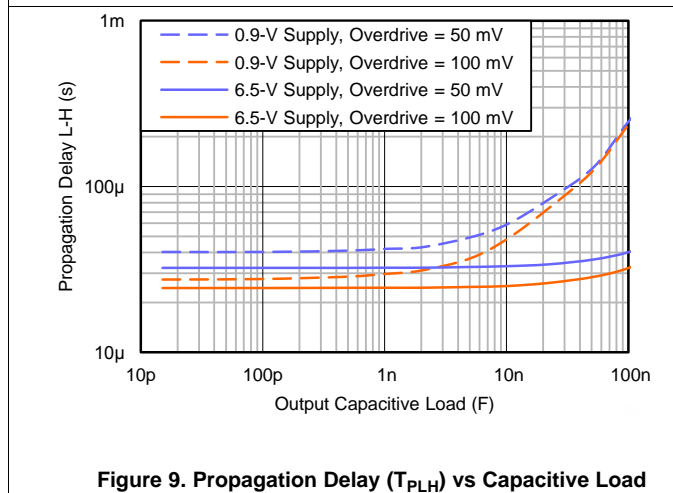
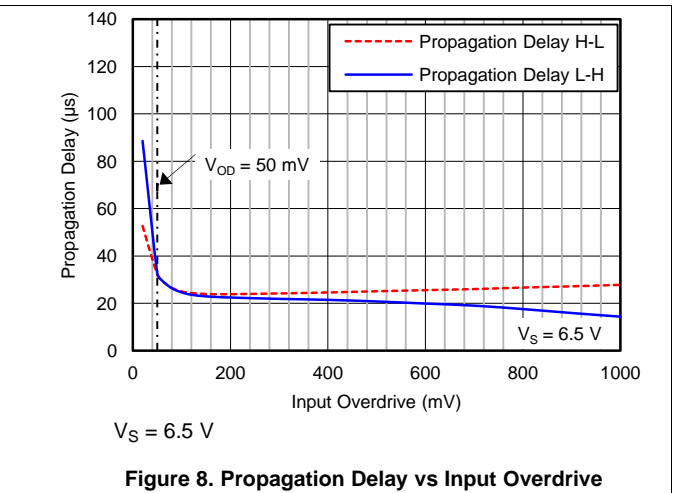
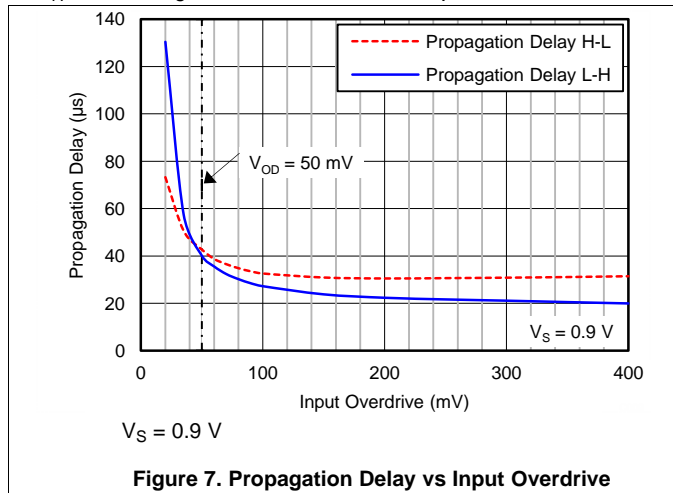

Figure 6. Short Circuit Current vs Temperature

Typical Characteristics (continued)

At $T_A = 25^\circ\text{C}$, $V_S = 0.9\text{ V}$ to 6.5 V , and input overdrive = 100 mV , unless otherwise noted.



Typical Characteristics (continued)

At $T_A = 25^\circ\text{C}$, $V_S = 0.9\text{ V}$ to 6.5 V , and input overdrive = 100 mV , unless otherwise noted.

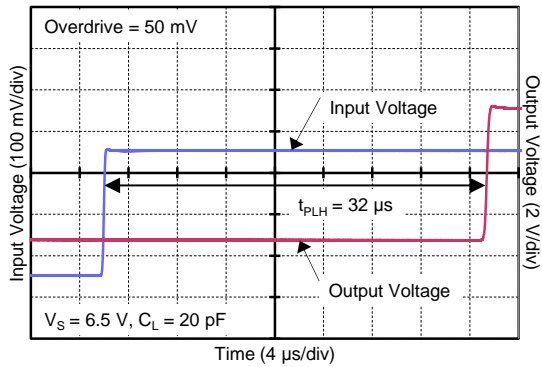

$V_S = 6.5\text{ V}$ Overdrive = 50 mV

Figure 13. Propagation Delay (T_{PLH})

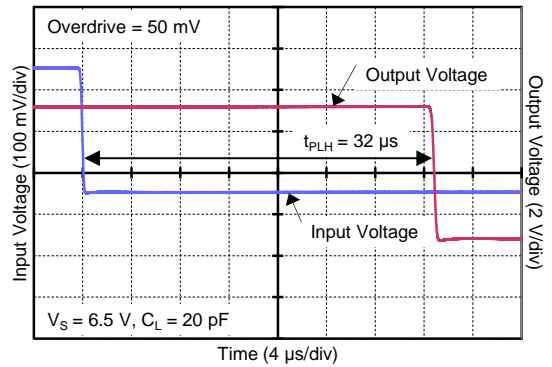

$V_S = 6.5\text{ V}$ Overdrive = 50 mV

Figure 14. Propagation Delay (T_{PHL})

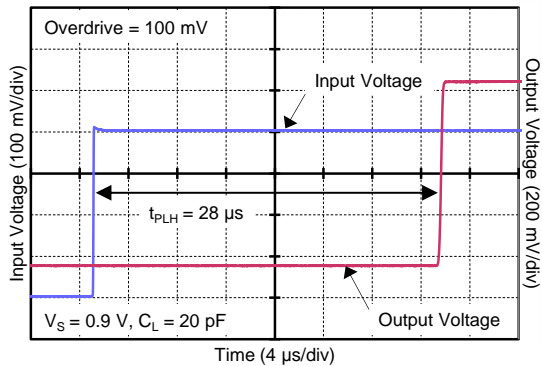

$V_S = 0.9\text{ V}$, Overdrive = 100 mV

Figure 15. Propagation Delay (T_{PLH})

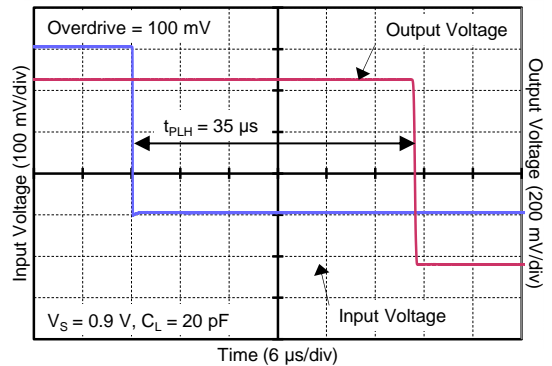

$V_S = 0.9\text{ V}$ Overdrive = 100 mV

Figure 16. Propagation Delay (T_{PHL})

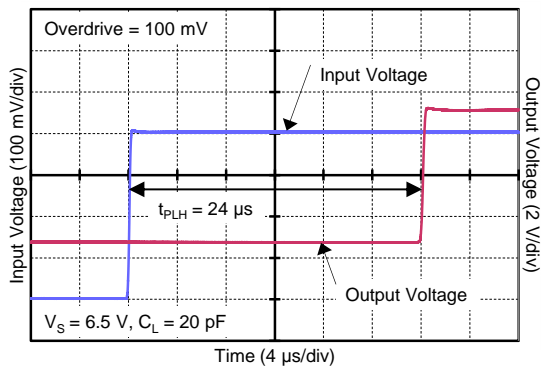

$V_S = 6.5\text{ V}$ Overdrive = 100 mV

Figure 17. Propagation Delay (T_{PLH})

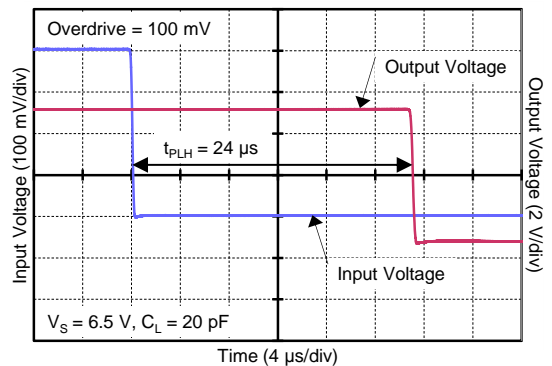

$V_S = 6.5\text{ V}$ Overdrive = 100 mV

Figure 18. Propagation Delay (T_{PHL})

Typical Characteristics (continued)

At $T_A = 25^\circ\text{C}$, $V_S = 0.9\text{ V}$ to 6.5 V , and input overdrive = 100 mV , unless otherwise noted.

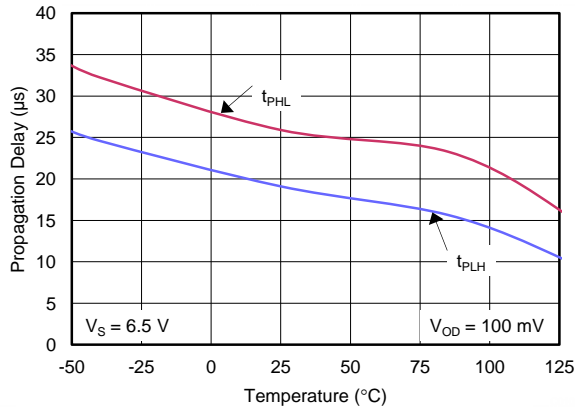

Figure 19. Propagation Delay vs Temperature

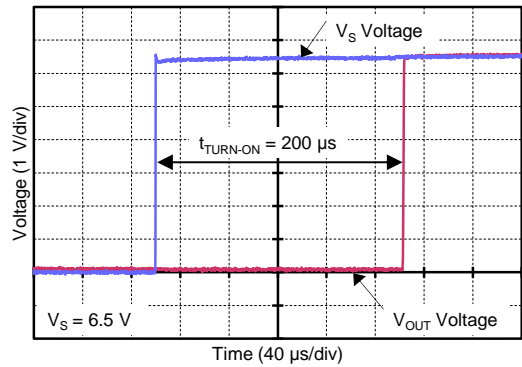
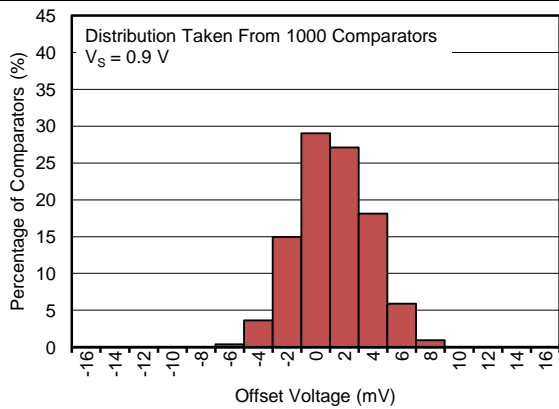
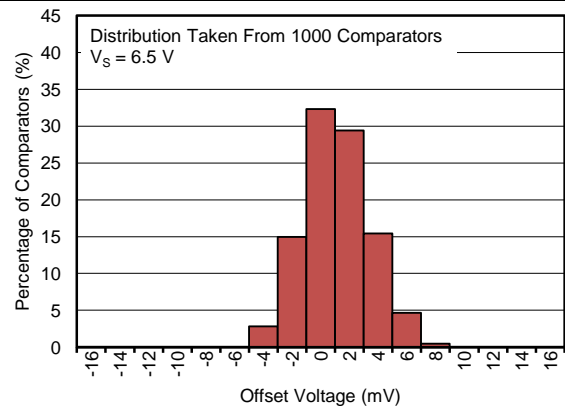

Figure 20. Start-Up Time



$V_S = 0.9\text{ V}$

Figure 21. Offset Voltage Production Distribution



$V_S = 6.5\text{ V}$

Figure 22. Offset Voltage Production Distribution

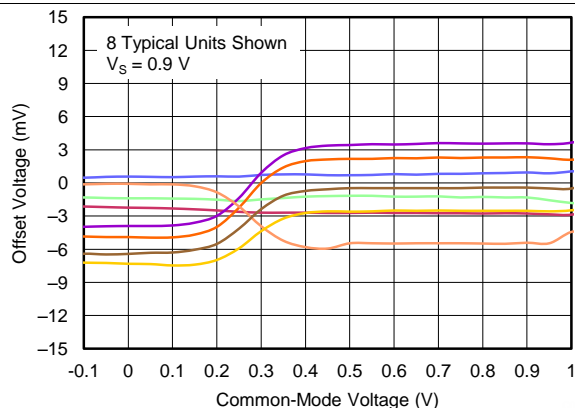

$V_S = 0.9\text{ V}$

Figure 23. Offset Voltage vs Common-Mode Voltage

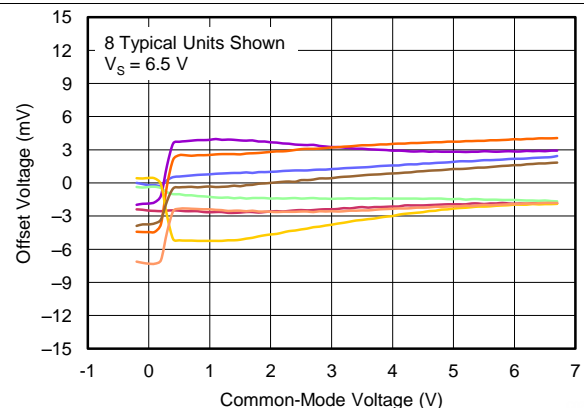

$V_S = 6.5\text{ V}$

Figure 24. Offset Voltage vs Common-Mode Voltage

Typical Characteristics (continued)

At $T_A = 25^\circ\text{C}$, $V_S = 0.9\text{ V}$ to 6.5 V , and input overdrive = 100 mV , unless otherwise noted.

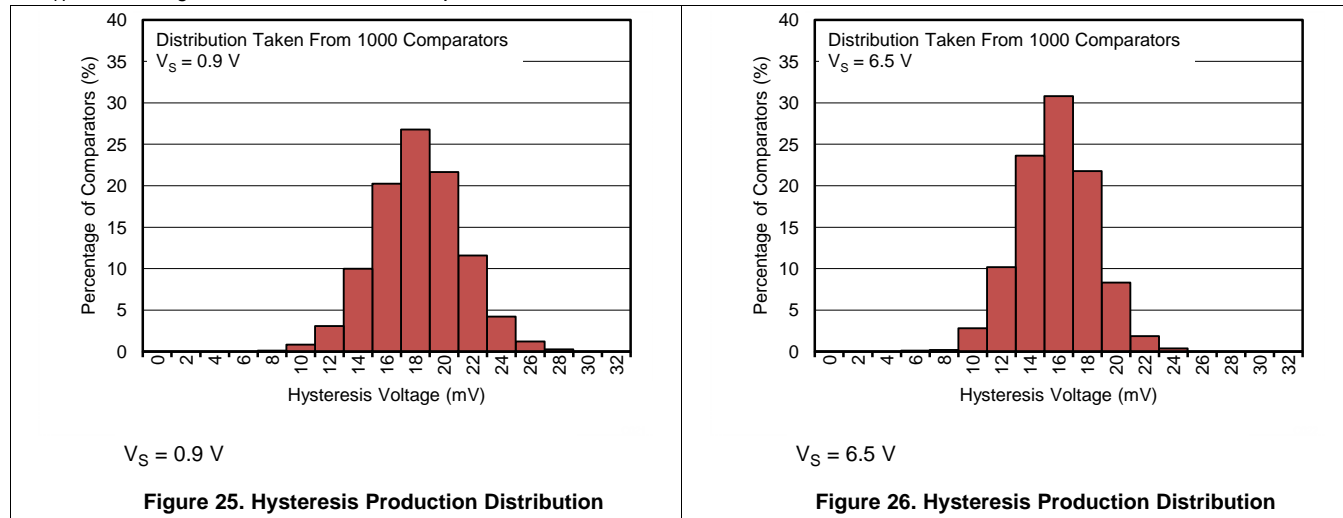

7 Detailed Description

7.1 Overview

The TLV3691 is a nano-power comparator with push-pull output. Operating from 0.9 V to 6.5 V and consuming a maximum quiescent current of only 200 nA over the temperature range from -40°C to 125°C , the TLV3691 is ideally suited for portable and industrial applications. The TLV3691 is available in the 5-pin SC70 and 6-pin DFN packages.

7.2 Functional Block Diagram

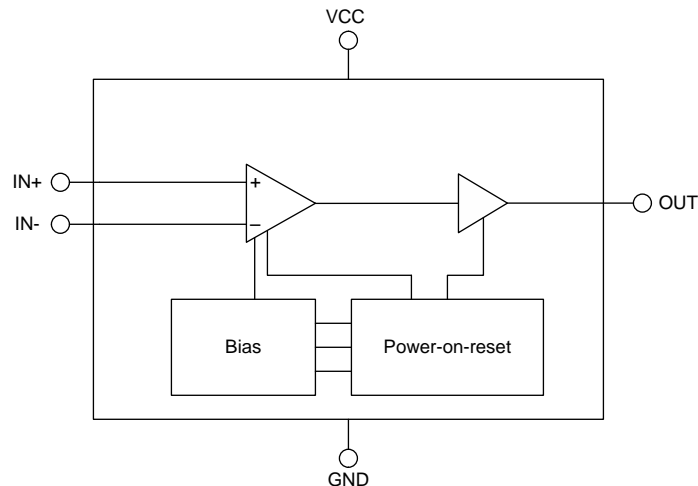

7.3 Feature Description

The TLV3691 features a nano-power comparator capable of operating at low voltages. The TLV3691 features a rail-to-rail input stage capable of operating up to 100 mV beyond each power supply rail. The TLV3691 also features a push-pull output stage with internal hysteresis.

7.4 Device Functional Modes

The TLV3691 has a single functional mode and is operational when the power supply voltage is greater than 0.9 V. The maximum power supply voltage for the TLV3691 is 6.5 V.

7.4.1 Nano-Power

The TLV3691 features nano-power operation. With a maximum of 150 nA of operating current at 25°C , the TLV3691 is ideally suited for portable and battery powered applications. With a maximum of 200 nA of operating current over the temperature range from -40°C to 125°C , the TLV3691 is also ideally suited for industrial applications and is a must have in every designer's toolbox.

7.4.2 Rail-to-Rail Inputs

The TLV3691 features an input stage capable of operating up to -100 mV beyond ground and 100 mV beyond the positive supply voltage, allowing for ease of use and flexible design options. Internal hysteresis of 17 mV (typical) allows for operation in noisy environments without the need for additional external components.

7.4.3 Push-Pull Output

The TLV3691 features a push-pull output, eliminating the need for an external pullup resistor and allows for nano-power operation across all operating conditions.

8 Application and Implementation

NOTE

Information in the following applications sections is not part of the TI component specification, and TI does not warrant its accuracy or completeness. TI's customers are responsible for determining suitability of components for their purposes. Customers should validate and test their design implementation to confirm system functionality.

8.1 Application Information

The TLV3691 comparators feature rail-to-rail inputs and outputs on supply voltages as low as 0.9 V. The push-pull output stage is optimal for reduced power budget applications and features no shoot-through current. Low minimum supply voltages, common-mode input range beyond supply rails, and a typical supply current of 75 nA make the TLV3691 an excellent candidate for battery-operated and portable, handheld designs.

8.1.1 Comparator Inputs

The TLV3691 is a rail-to-rail input comparator, with an input common-mode range that exceeds the supply rails by 100 mV for both positive and negative supplies. The device is designed to prevent phase inversion when the input pins exceed the supply voltage. Figure 27 shows the device response when input voltages exceed the supply, resulting in no phase inversion.

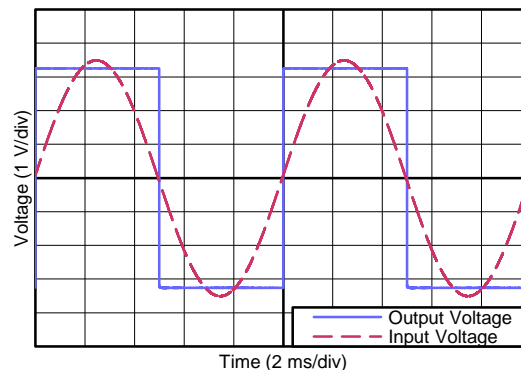
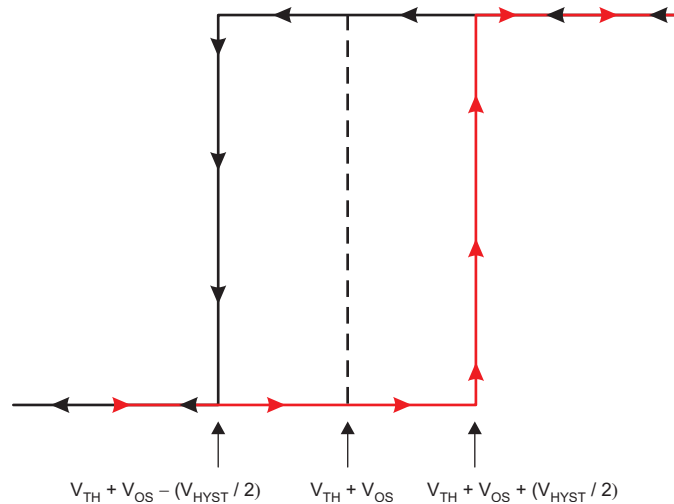

Figure 27. No Phase Inversion: Comparator Response to Input Voltage (Propagation Delay Included)

8.1.2 External Hysteresis

The device hysteresis transfer curve is shown in Figure 28. This curve is a function of three components: V_{TH} , V_{OS} , and V_{HYST} .

- V_{TH} is the actual set voltage or threshold trip voltage.
- V_{OS} is the internal offset voltage between V_{IN+} and V_{IN-} . This voltage is added to V_{TH} to form the actual trip point at which the comparator must respond to change output states.
- V_{HYST} is the internal hysteresis (or trip window) that is designed to reduce comparator sensitivity to noise (17 mV for the TLV3691).

Application Information (continued)

Figure 28. Hysteresis Transfer Curve
8.1.2.1 Inverting Comparator With Hysteresis

The inverting comparator with hysteresis requires a three-resistor network that is referenced to the comparator supply voltage (V_{CC}), as shown in Figure 29. When V_{IN} at the inverting input is less than V_A , the output voltage is high (for simplicity, assume V_O switches as high as V_{CC}). The three network resistors can be represented as $R1 \parallel R3$ in series with $R2$. Equation 1 defines the high-to-low trip voltage (V_{A1}).

$$V_{A1} = V_{CC} \times \frac{R2}{(R1 \parallel R3) + R2} \quad (1)$$

When V_{IN} is greater than V_A , the output voltage is low, very close to ground. In this case, the three network resistors can be presented as $R2 \parallel R3$ in series with $R1$. Use Equation 2 to define the low to high trip voltage (V_{A2}).

$$V_{A2} = V_{CC} \times \frac{R2 \parallel R3}{R1 + (R2 \parallel R3)} \quad (2)$$

Equation 3 defines the total hysteresis provided by the network.

$$\Delta V_A = V_{A1} - V_{A2} \quad (3)$$

Application Information (continued)

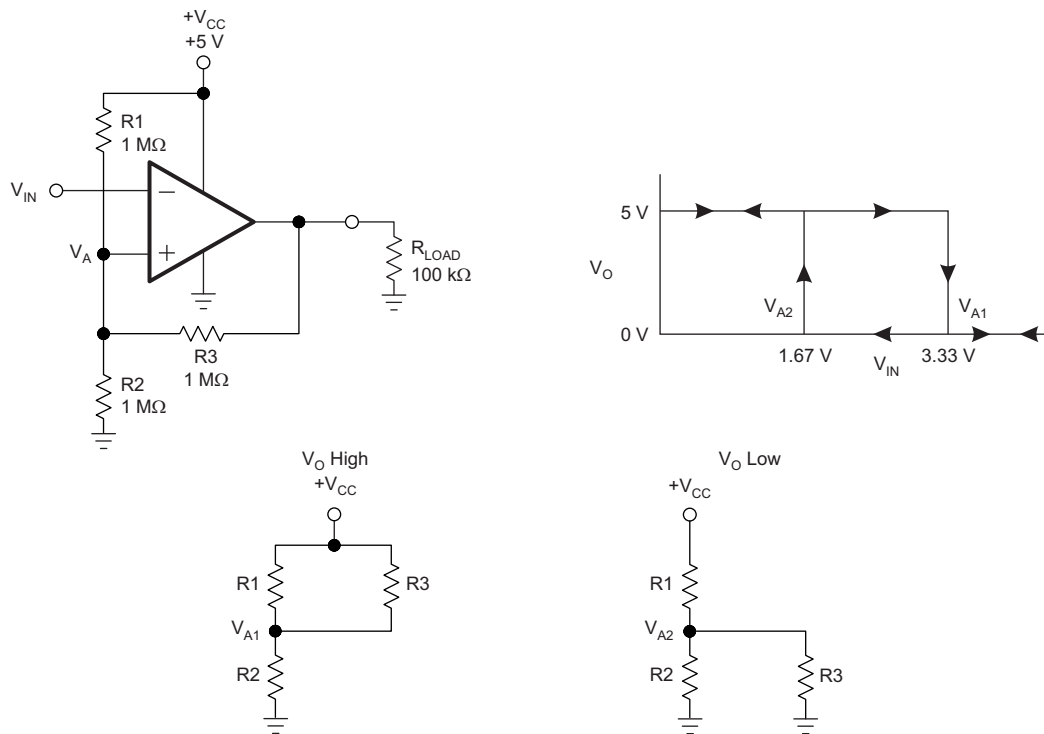

Figure 29. TLV3691 in an Inverting Configuration With Hysteresis

8.1.2.2 Noninverting Comparator With Hysteresis

A noninverting comparator with hysteresis requires a two-resistor network, as shown in Figure 30, and a voltage reference (V_{REF}) at the inverting input. When V_{IN} is low, the output is also low. For the output to switch from low to high, V_{IN} must rise to V_{IN1}. Use Equation 4 to calculate V_{IN1}.

$$V_{IN1} = R1 \times \frac{V_{REF}}{R2} + V_{REF} \tag{4}$$

When V_{IN} is high, the output is also high. For the comparator to switch back to a low state, V_{IN} must drop to V_{IN2} such that V_A is equal to V_{REF}. Use Equation 5 to calculate V_{IN2}.

$$V_{IN2} = \frac{V_{REF} (R1 + R2) - V_{CC} \times R1}{R2} \tag{5}$$

The hysteresis of this circuit is the difference between V_{IN1} and V_{IN2}, as shown in Equation 6.

$$\Delta V_{IN} = V_{CC} \times \frac{R1}{R2} \tag{6}$$

Application Information (continued)

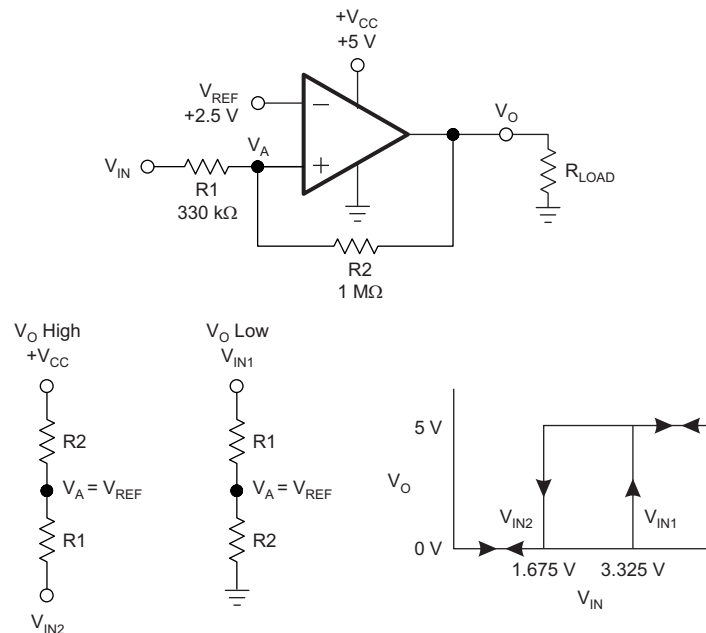

Figure 30. TLV3691 in a Noninverting Configuration With Hysteresis

8.1.3 Capacitive Loads

Under reasonable capacitive loads, the device maintains specified propagation delay (see [Typical Characteristics](#)). However, excessive capacitive loading under high switching frequencies may increase supply current, propagation delay, or induce decreased slew rate.

8.1.4 Setting the Reference Voltage

Using a stable reference when setting the transition point for the device is important. The [REF3312](#), as shown in [Figure 31](#), provides a 1.25-V reference voltage with low drift and only 3.9 μ A of quiescent current.

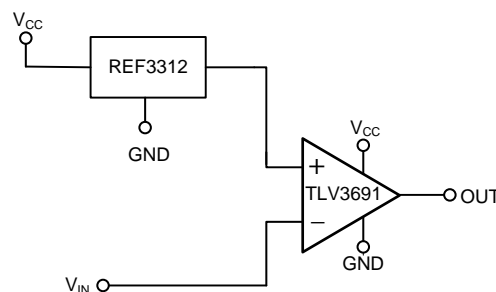

Figure 31. Reference Voltage for the TLV3691

8.2 Typical Application

8.2.1 Window Comparator

Window comparators are commonly used to detect undervoltage and overvoltage conditions. [Figure 32](#) illustrates a simple window comparator circuit.

Typical Application (continued)

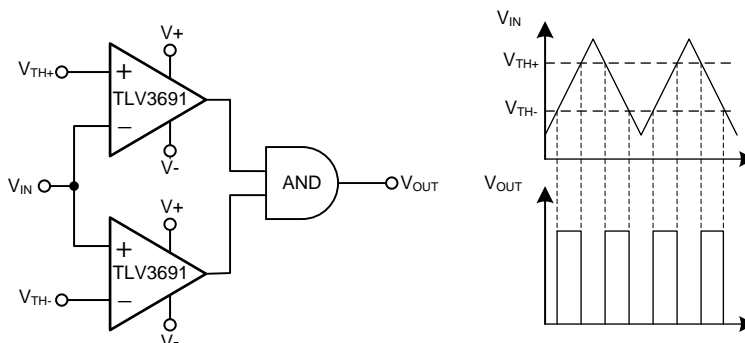

Figure 32. Window Comparator

8.2.1.1 Design Requirements

- Alert when an input signal is less than 1.25 V
- Alert when an input signal is greater than 3.3 V
- Alert signal is active low
- Operate from 5-V power supply
- Consume less than 1 μ A over the temperature range from -40°C to 125°C

8.2.1.2 Detailed Design Procedure

Configure the circuit as shown in Figure 32. Connect V+ to a 5-V power supply. Connect V- to ground. Connect V_{TH-} to a 1.25-V voltage source; this can be a low power voltage reference such as REF3312. Connect V_{TH+} to a 3.3-V voltage source; this can be a low power voltage reference such as REF3333. Apply an input voltage at V_{IN}. V_{OUT} will be low when V_{IN} is less than 1.25 V or greater than 3.3 V. V_{OUT} will be high when V_{IN} is in the range of 1.25 V to 3.3 V.

8.2.1.3 Application Curve

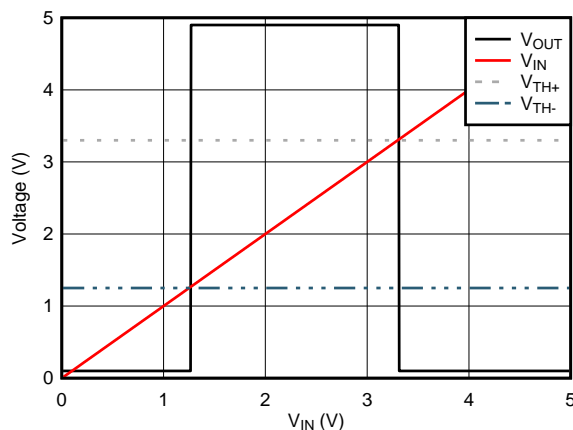

Figure 33. Window Comparator Results

8.2.2 Overvoltage and Undervoltage Detection

The TLV3691 can be easily configured as an overvoltage and undervoltage detection circuit. Figure 34 illustrates an overvoltage and undervoltage detection circuit. This circuit can be configured to detect the validity of a bus voltage source. The outputs of the TLV3691 will transition low when the bus voltage is out of range.

- A bus voltage overvoltage condition is indicated when V_{OV} is low. V_{OV} will transition low according to Equation 7.

Typical Application (continued)

$$V_{BUS} \times \left(\frac{R_A}{R_A + R_B + R_C} \right) > V_{TH} \quad (7)$$

- A bus voltage undervoltage condition is indicated when V_{UV} is low. V_{UV} will transition low according to [Equation 8](#).

$$V_{BUS} \times \left(\frac{R_A + R_B}{R_A + R_B + R_C} \right) < V_{TH} \quad (8)$$

- V_{OV} and V_{UV} will both be high when the bus voltage is within the desired range determined by [Equation 7](#) and [Equation 8](#).

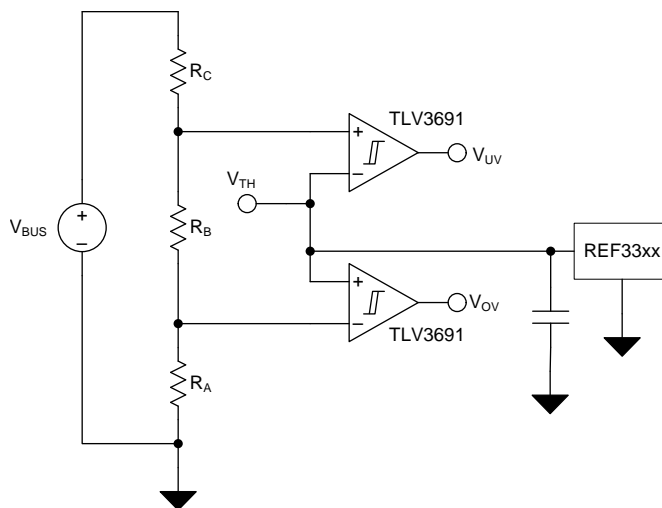
Figure 34. Overvoltage and Undervoltage Detection
9 Power Supply Recommendations

The TLV3691 is specified for operation from 0.9 V to 6.5 V. Many specifications apply from -40°C to 125°C . Parameters capable of exhibiting significant variance regarding the operating voltage or temperature are presented in the [Typical Characteristics](#).

10 Layout

10.1 Layout Guidelines

Comparators are very sensitive to input noise. For best results, adhere to the following layout guidelines.

1. Use a printed-circuit-board (PCB) with a good, unbroken, low-inductance ground plane. Proper grounding (use of a ground plane) helps maintain specified device performance.
2. To minimize supply noise, place a decoupling capacitor (0.1- μ F ceramic, surface-mount capacitor) as close as possible to V_{CC} .
3. On the inputs and the output, keep lead lengths as short as possible to avoid unwanted parasitic feedback around the comparator. Keep inputs away from the output.
4. Solder the device directly to the PCB rather than using a socket.
5. For slow-moving input signals, take care to prevent parasitic feedback. A small capacitor (1000 pF or less) placed between the inputs can help eliminate oscillations in the transition region. This capacitor causes some degradation to propagation delay when impedance is low. The topside ground plane runs between the output and inputs.
6. The ground pin ground trace runs under the device up to the bypass capacitor, shielding the inputs from the outputs.

10.2 Layout Example

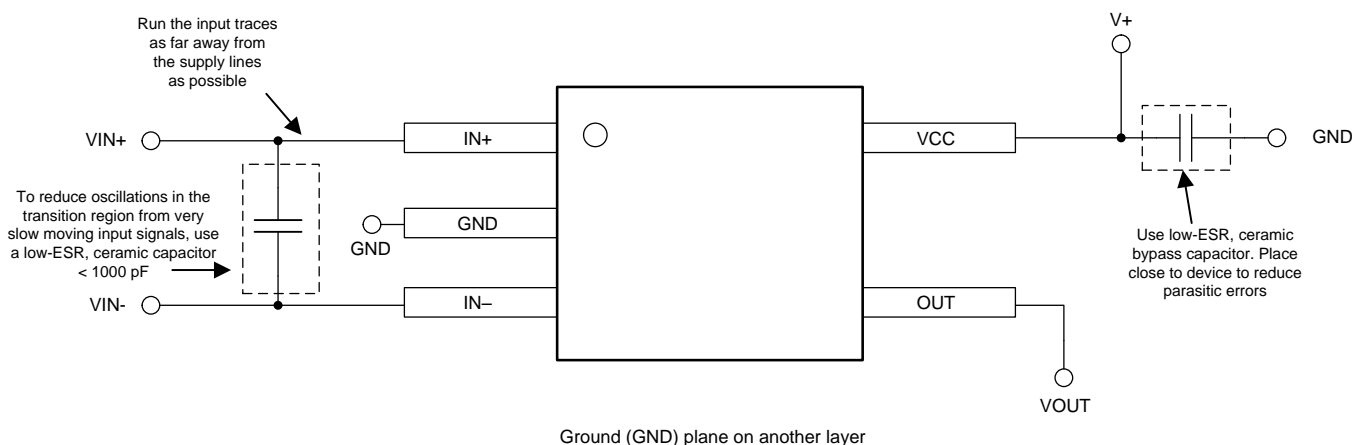

Figure 35. TLV3691 Layout Example

11 器件和文档支持

11.1 器件支持

11.1.1 开发支持

11.1.1.1 TINA-TI™ (免费下载)

TINA™是一款简单、功能强大且易于使用的电路仿真程序，此程序基于 SPICE 引擎。TINA-TI 是 TINA 软件的一款免费全功能版本，除了一系列无源和有源模型外，此版本软件还预先载入了一个宏模型库。TINA-TI 提供所有传统的 SPICE 直流、瞬态和频域分析，以及其他设计功能。

TINA-TI 可从 Analog eLab Design Center (模拟电子实验室设计中心) [免费下载](#)，它提供全面的后续处理能力，使得用户能够以多种方式形成结果。虚拟仪器提供选择输入波形和探测电路节点、电压和波形的功能，从而创建一个动态的快速入门工具。

注

这些文件需要安装 TINA 软件 (由 DesignSoft™提供) 或者 TINA-TI 软件。请从 [TINA-TI 文件夹](#) 中下载免费的 TINA-TI 软件。

11.1.1.2 TI 高精度设计

OPAx188 (或类似运算放大器) 采用多种 TI 高精度设计。如需获取相关内容，请访问 <http://www.ti.com.cn/ww/analog/precision-designs/>。TI 高精度设计是由 TI 公司高精度模拟应用专家创建的模拟解决方案，提供了许多实用电路的工作原理、组件选择、仿真、完整印刷电路板 (PCB) 电路原理图和布局布线、物料清单以及性能测量结果。

11.2 文档支持

11.2.1 相关文档

相关文档如下：

- 《电路板布局布线技巧》，[SLOA089](#)。
- 《适用于所有人的运算放大器》，[SLOD006](#)。
- 《无铅组件涂层的保存期评估》，[SZZA046](#)。

11.3 社区资源

The following links connect to TI community resources. Linked contents are provided "AS IS" by the respective contributors. They do not constitute TI specifications and do not necessarily reflect TI's views; see TI's [Terms of Use](#).

TI E2E™ Online Community *TI's Engineer-to-Engineer (E2E) Community*. Created to foster collaboration among engineers. At e2e.ti.com, you can ask questions, share knowledge, explore ideas and help solve problems with fellow engineers.

Design Support *TI's Design Support* Quickly find helpful E2E forums along with design support tools and contact information for technical support.

11.4 商标

E2E is a trademark of Texas Instruments.

TINA-TI is a trademark of Texas Instruments, Inc and DesignSoft, Inc.

TINA, DesignSoft are trademarks of DesignSoft, Inc.

All other trademarks are the property of their respective owners.

11.5 静电放电警告



这些装置包含有限的内置 ESD 保护。存储或装卸时，应将导线一起截短或将装置放置于导电泡棉中，以防止 MOS 门极遭受静电损伤。

11.6 Glossary

[SLYZ022](#) — *TI Glossary*.

This glossary lists and explains terms, acronyms, and definitions.

12 机械、封装和可订购信息

以下页中包括机械、封装和可订购信息。这些信息是针对指定器件可提供的最新数据。这些数据会在无通知且不对本文档进行修订的情况下发生改变。欲获得该数据表的浏览器版本，请查阅左侧的导航栏。

重要声明

德州仪器(TI)及其下属子公司有权根据 JESD46 最新标准,对所提供的产品和服务进行更正、修改、增强、改进或其它更改,并有权根据 JESD48 最新标准中止提供任何产品和服务。客户在下订单前应获取最新的相关信息,并验证这些信息是否完整且是最新的。所有产品的销售都遵循在订单确认时所提供的TI 销售条款与条件。

TI 保证其所销售的组件的性能符合产品销售时 TI 半导体产品销售条件与条款的适用规范。仅在 TI 保证的范围内,且 TI 认为有必要时才会使用测试或其它质量控制技术。除非适用法律做出了硬性规定,否则没有必要对每种组件的所有参数进行测试。

TI 对应用帮助或客户产品设计不承担任何义务。客户应对其使用 TI 组件的产品和应用自行负责。为尽量减小与客户产品和应用相关的风险,客户应提供充分的设计与操作安全措施。

TI 不对任何 TI 专利权、版权、屏蔽作品权或其它与使用了 TI 组件或服务的组合设备、机器或流程相关的 TI 知识产权中授予的直接或隐含权限作出任何保证或解释。TI 所发布的与第三方产品或服务有关的信息,不能构成从 TI 获得使用这些产品或服务的许可、授权、或认可。使用此类信息可能需要获得第三方的专利权或其它知识产权方面的许可,或是 TI 的专利权或其它知识产权方面的许可。

对于 TI 的产品手册或数据表中 TI 信息的重要部分,仅在没有对内容进行任何篡改且带有相关授权、条件、限制和声明的情况下才允许进行复制。TI 对此类篡改过的文件不承担任何责任或义务。复制第三方的信息可能需要服从额外的限制条件。

在转售 TI 组件或服务时,如果对该组件或服务参数的陈述与 TI 标明的参数相比存在差异或虚假成分,则会失去相关 TI 组件或服务的所有明示或暗示授权,且这是不正当的、欺诈性商业行为。TI 对任何此类虚假陈述均不承担任何责任或义务。

客户认可并同意,尽管任何应用相关信息或支持仍可能由 TI 提供,但他们将独立负责满足与其产品及其在应用中使用的 TI 产品相关的所有法律、法规和安全相关要求。客户声明并同意,他们具备制定与实施安全措施所需的全部专业技术和知识,可预见故障的危险后果、监测故障及其后果、降低有可能造成人身伤害的故障的发生机率并采取适当的补救措施。客户将全额赔偿因在此类安全关键应用中使用任何 TI 组件而对 TI 及其代理造成的任何损失。

在某些场合中,为了推进安全相关应用有可能对 TI 组件进行特别的促销。TI 的目标是利用此类组件帮助客户设计和创立其特有的可满足适用的功能安全性标准和要求的终端产品解决方案。尽管如此,此类组件仍然服从这些条款。

TI 组件未获得用于 FDA Class III (或类似的生命攸关医疗设备)的授权许可,除非各方授权官员已经达成了专门管控此类使用的特别协议。

只有那些 TI 特别注明属于军用等级或“增强型塑料”的 TI 组件才是设计或专门用于军事/航空应用或环境的。购买者认可并同意,对并非指定面向军事或航空航天用途的 TI 组件进行军事或航空航天方面的应用,其风险由客户单独承担,并且由客户独立负责满足与此类使用相关的所有法律和法规要求。

TI 已明确指定符合 ISO/TS16949 要求的产品,这些产品主要用于汽车。在任何情况下,因使用非指定产品而无法达到 ISO/TS16949 要求, TI 不承担任何责任。

	产品		应用
数字音频	www.ti.com.cn/audio	通信与电信	www.ti.com.cn/telecom
放大器和线性器件	www.ti.com.cn/amplifiers	计算机及周边	www.ti.com.cn/computer
数据转换器	www.ti.com.cn/dataconverters	消费电子	www.ti.com.cn/consumer-apps
DLP® 产品	www.dlp.com	能源	www.ti.com.cn/energy
DSP - 数字信号处理器	www.ti.com.cn/dsp	工业应用	www.ti.com.cn/industrial
时钟和计时器	www.ti.com.cn/clockandtimers	医疗电子	www.ti.com.cn/medical
接口	www.ti.com.cn/interface	安防应用	www.ti.com.cn/security
逻辑	www.ti.com.cn/logic	汽车电子	www.ti.com.cn/automotive
电源管理	www.ti.com.cn/power	视频和影像	www.ti.com.cn/video
微控制器 (MCU)	www.ti.com.cn/microcontrollers		
RFID 系统	www.ti.com.cn/rfidsys		
OMAP应用处理器	www.ti.com/omap		
无线连通性	www.ti.com.cn/wirelessconnectivity	德州仪器在线技术支持社区	www.deyisupport.com

邮寄地址: 上海市浦东新区世纪大道1568号, 中建大厦32楼邮政编码: 200122
Copyright © 2016, 德州仪器半导体技术(上海)有限公司

PACKAGING INFORMATION

Orderable Device	Status (1)	Package Type	Package Drawing	Pins	Package Qty	Eco Plan (2)	Lead finish/ Ball material (6)	MSL Peak Temp (3)	Op Temp (°C)	Device Marking (4/5)	Samples
TLV3691IDCKR	ACTIVE	SC70	DCK	5	3000	RoHS & Green	NIPDAU	Level-2-260C-1 YEAR	-40 to 125	SIV	Samples
TLV3691IDCKT	ACTIVE	SC70	DCK	5	250	RoHS & Green	NIPDAU	Level-2-260C-1 YEAR	-40 to 125	SIV	Samples
TLV3691IDPFR	ACTIVE	X2SON	DPF	6	5000	RoHS & Green	NIPDAU	Level-1-260C-UNLIM	-40 to 125	EW	Samples
TLV3691IDPFT	ACTIVE	X2SON	DPF	6	250	RoHS & Green	NIPDAU	Level-1-260C-UNLIM	-40 to 125	EW	Samples

(1) The marketing status values are defined as follows:

ACTIVE: Product device recommended for new designs.

LIFEBUY: TI has announced that the device will be discontinued, and a lifetime-buy period is in effect.

NRND: Not recommended for new designs. Device is in production to support existing customers, but TI does not recommend using this part in a new design.

PREVIEW: Device has been announced but is not in production. Samples may or may not be available.

OBSOLETE: TI has discontinued the production of the device.

(2) **RoHS:** TI defines "RoHS" to mean semiconductor products that are compliant with the current EU RoHS requirements for all 10 RoHS substances, including the requirement that RoHS substance do not exceed 0.1% by weight in homogeneous materials. Where designed to be soldered at high temperatures, "RoHS" products are suitable for use in specified lead-free processes. TI may reference these types of products as "Pb-Free".

RoHS Exempt: TI defines "RoHS Exempt" to mean products that contain lead but are compliant with EU RoHS pursuant to a specific EU RoHS exemption.

Green: TI defines "Green" to mean the content of Chlorine (Cl) and Bromine (Br) based flame retardants meet JS709B low halogen requirements of <=1000ppm threshold. Antimony trioxide based flame retardants must also meet the <=1000ppm threshold requirement.

(3) MSL, Peak Temp. - The Moisture Sensitivity Level rating according to the JEDEC industry standard classifications, and peak solder temperature.

(4) There may be additional marking, which relates to the logo, the lot trace code information, or the environmental category on the device.

(5) Multiple Device Markings will be inside parentheses. Only one Device Marking contained in parentheses and separated by a "-" will appear on a device. If a line is indented then it is a continuation of the previous line and the two combined represent the entire Device Marking for that device.

(6) Lead finish/Ball material - Orderable Devices may have multiple material finish options. Finish options are separated by a vertical ruled line. Lead finish/Ball material values may wrap to two lines if the finish value exceeds the maximum column width.

Important Information and Disclaimer:The information provided on this page represents TI's knowledge and belief as of the date that it is provided. TI bases its knowledge and belief on information provided by third parties, and makes no representation or warranty as to the accuracy of such information. Efforts are underway to better integrate information from third parties. TI has taken and

continues to take reasonable steps to provide representative and accurate information but may not have conducted destructive testing or chemical analysis on incoming materials and chemicals. TI and TI suppliers consider certain information to be proprietary, and thus CAS numbers and other limited information may not be available for release.

In no event shall TI's liability arising out of such information exceed the total purchase price of the TI part(s) at issue in this document sold by TI to Customer on an annual basis.

TAPE AND REEL INFORMATION

QUADRANT ASSIGNMENTS FOR PIN 1 ORIENTATION IN TAPE

*All dimensions are nominal

Device	Package Type	Package Drawing	Pins	SPQ	Reel Diameter (mm)	Reel Width W1 (mm)	A0 (mm)	B0 (mm)	K0 (mm)	P1 (mm)	W (mm)	Pin1 Quadrant
TLV3691IDCKR	SC70	DCK	5	3000	178.0	9.0	2.4	2.5	1.2	4.0	8.0	Q3
TLV3691IDCKT	SC70	DCK	5	250	178.0	8.4	2.4	2.5	1.2	4.0	8.0	Q3
TLV3691IDPFR	X2SON	DPF	6	5000	180.0	9.5	1.16	1.16	0.63	4.0	8.0	Q2
TLV3691IDPFT	X2SON	DPF	6	250	180.0	9.5	1.16	1.16	0.63	4.0	8.0	Q2

TAPE AND REEL BOX DIMENSIONS

*All dimensions are nominal

Device	Package Type	Package Drawing	Pins	SPQ	Length (mm)	Width (mm)	Height (mm)
TLV3691IDCKR	SC70	DCK	5	3000	190.0	190.0	30.0
TLV3691IDCKT	SC70	DCK	5	250	190.0	190.0	30.0
TLV3691IDPFR	X2SON	DPF	6	5000	184.0	184.0	19.0
TLV3691IDPFT	X2SON	DPF	6	250	184.0	184.0	19.0

DPF0006A

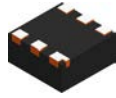

PACKAGE OUTLINE

X2SON - 0.4 mm max height

PLASTIC SMALL OUTLINE - NO LEAD

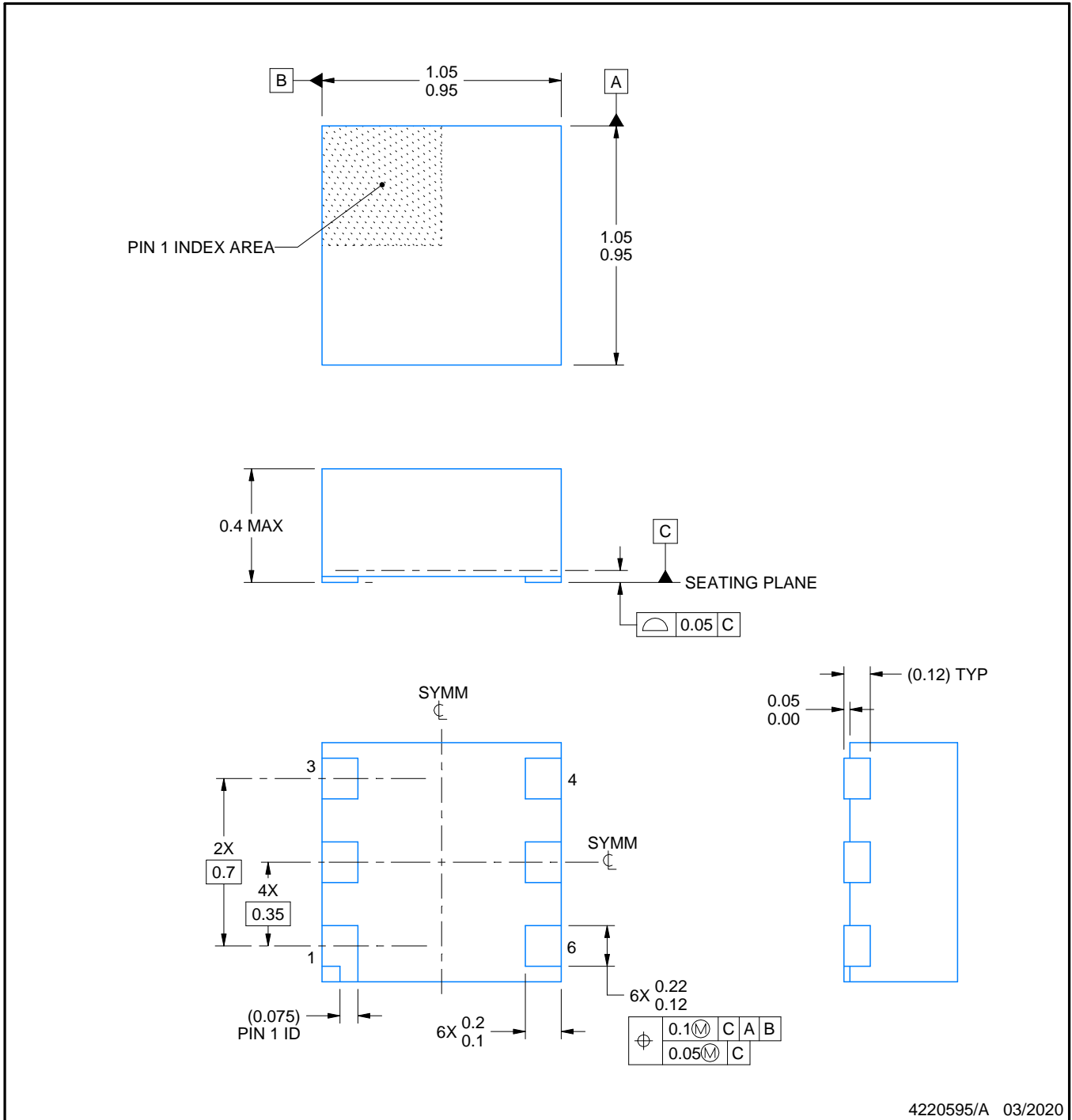

NOTES:

1. All linear dimensions are in millimeters. Any dimensions in parenthesis are for reference only. Dimensioning and tolerancing per ASME Y14.5M.
2. This drawing is subject to change without notice.
3. Reference JEDEC registration MO-287, variation X2AAF.

EXAMPLE BOARD LAYOUT

DPF0006A

X2SON - 0.4 mm max height

PLASTIC SMALL OUTLINE - NO LEAD

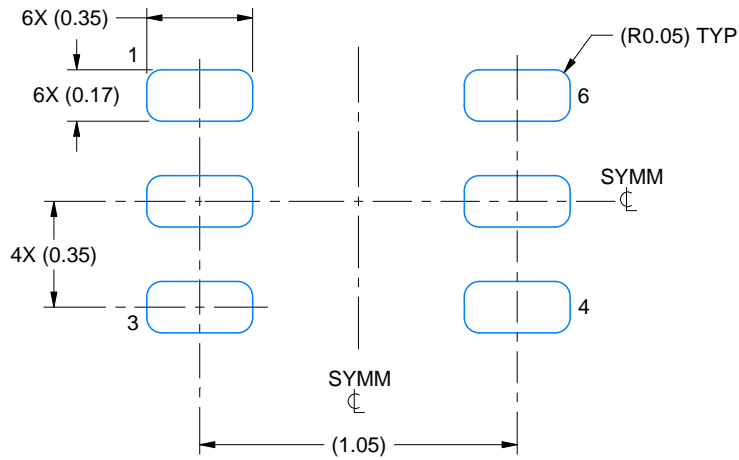

LAND PATTERN EXAMPLE
EXPOSED METAL SHOWN
SCALE:40X

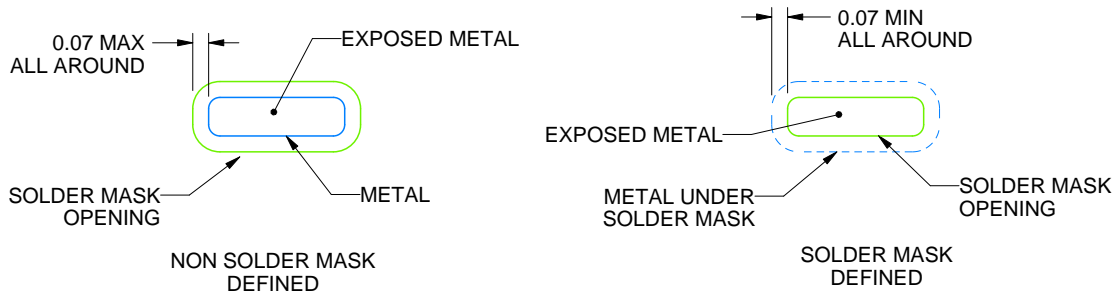

SOLDER MASK DETAILS

4220595/A 03/2020

NOTES: (continued)

4. For more information, see Texas Instruments literature number SLUA271 (www.ti.com/lit/slua271).

EXAMPLE STENCIL DESIGN

DPF0006A

X2SON - 0.4 mm max height

PLASTIC SMALL OUTLINE - NO LEAD

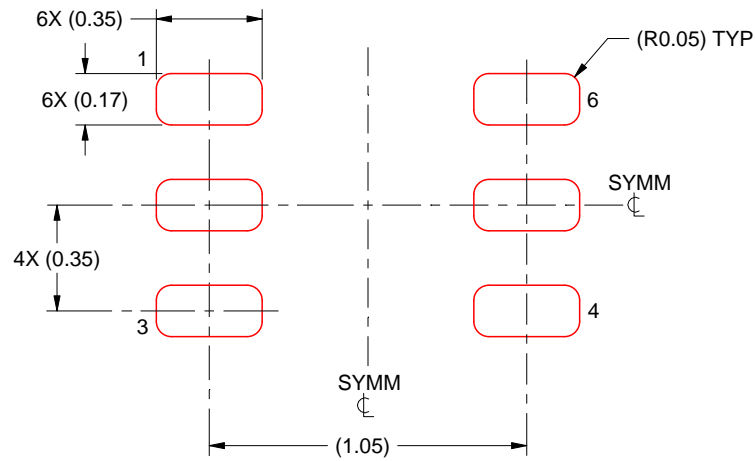

SOLDER PASTE EXAMPLE
BASED ON 0.1 mm THICK STENCIL

SCALE:40X

4220595/A 03/2020

4. Laser cutting apertures with trapezoidal walls and rounded corners may offer better paste release. IPC-7525 may have alternate design recommendations.

DCK (R-PDSO-G5)

PLASTIC SMALL-OUTLINE PACKAGE

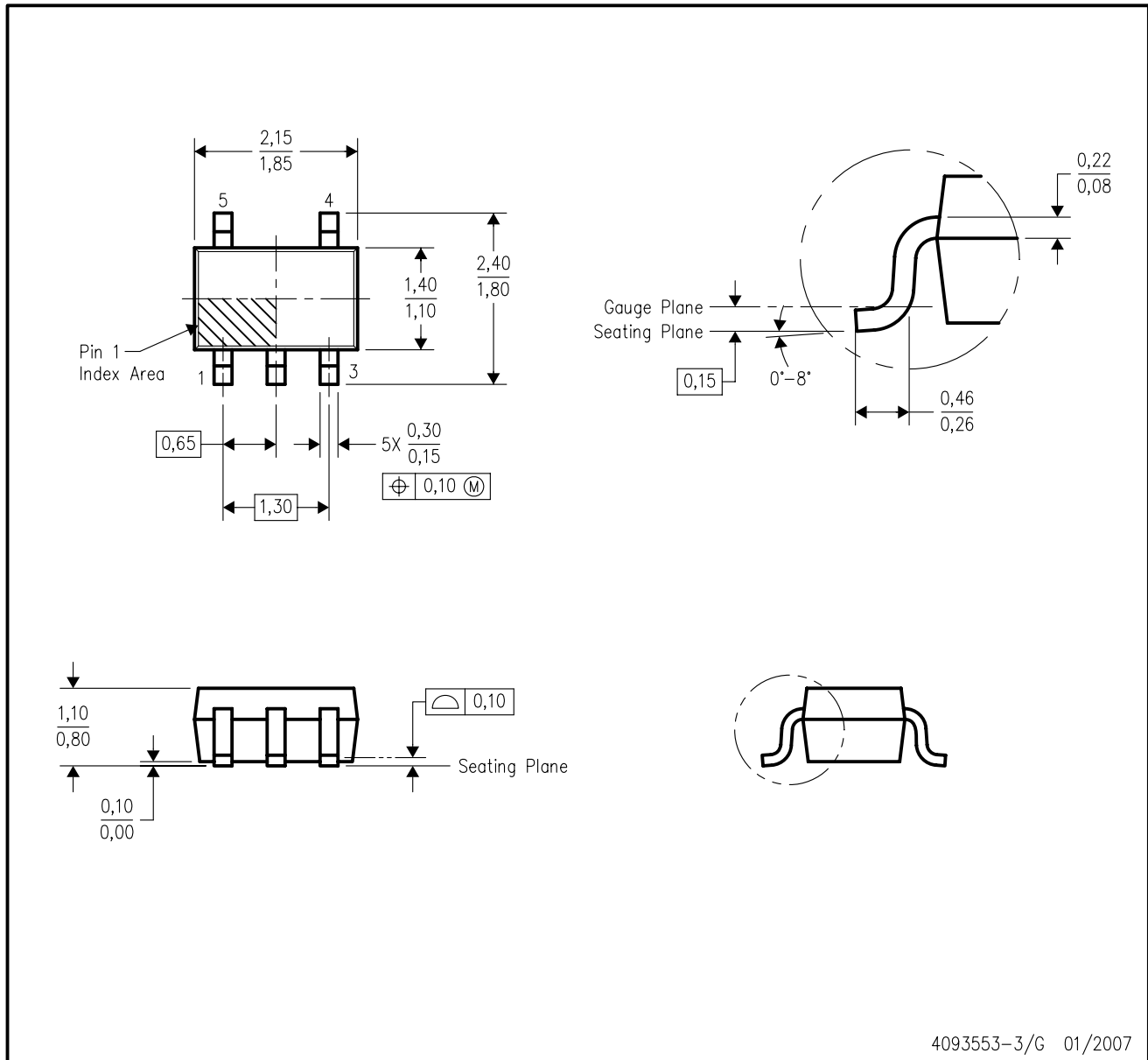

- NOTES:
- A. All linear dimensions are in millimeters.
 - B. This drawing is subject to change without notice.
 - C. Body dimensions do not include mold flash or protrusion. Mold flash and protrusion shall not exceed 0.15 per side.
 - D. Falls within JEDEC MO-203 variation AA.

DCK (R-PDSO-G5)

PLASTIC SMALL OUTLINE

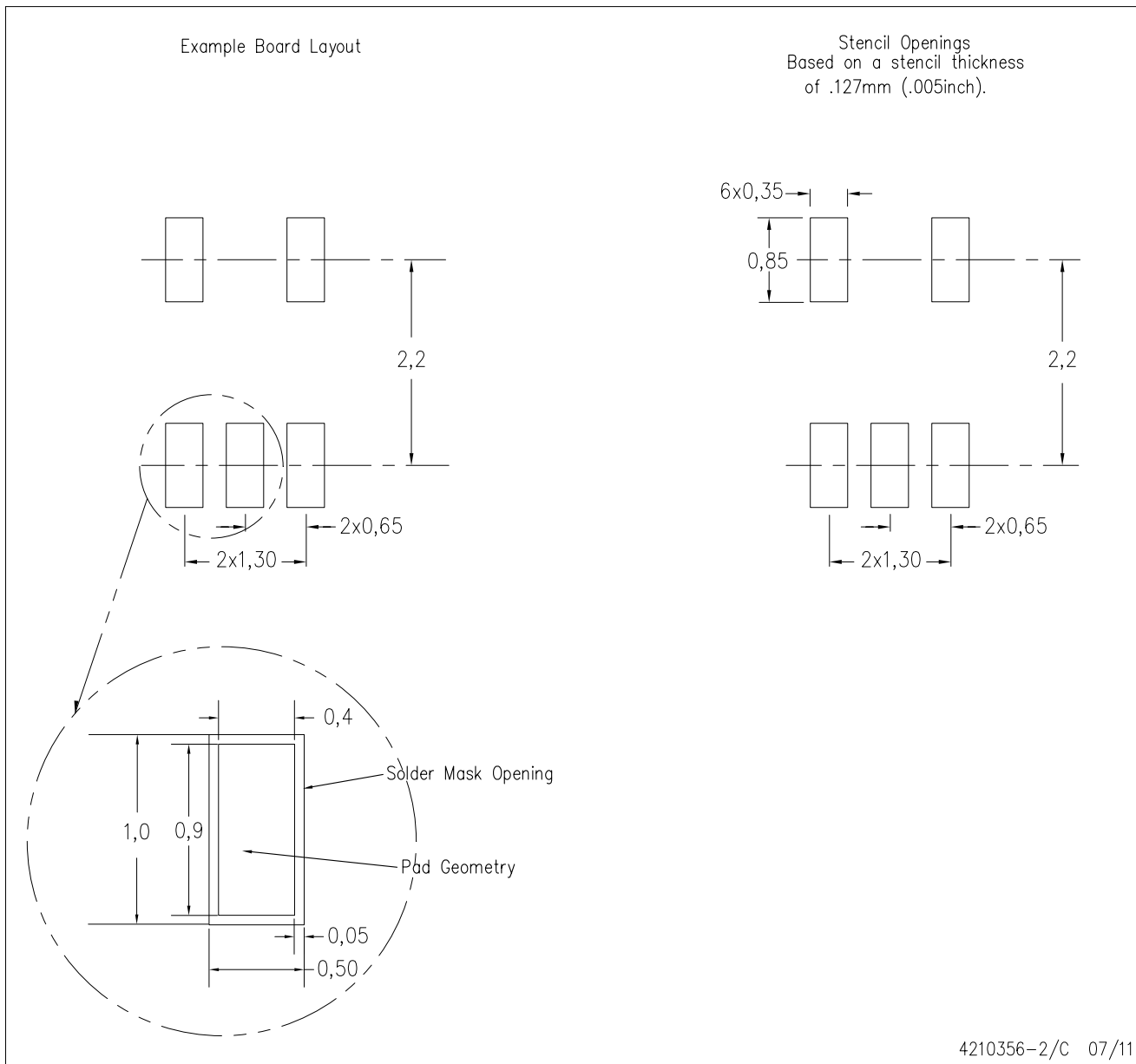

- NOTES:
- All linear dimensions are in millimeters.
 - This drawing is subject to change without notice.
 - Customers should place a note on the circuit board fabrication drawing not to alter the center solder mask defined pad.
 - Publication IPC-7351 is recommended for alternate designs.
 - Laser cutting apertures with trapezoidal walls and also rounding corners will offer better paste release. Customers should contact their board assembly site for stencil design recommendations. Example stencil design based on a 50% volumetric metal load solder paste. Refer to IPC-7525 for other stencil recommendations.

重要声明和免责声明

TI 均以“原样”提供技术性及其可靠性数据（包括数据表）、设计资源（包括参考设计）、应用或其他设计建议、网络工具、安全信息和其他资源，不保证其中不含任何瑕疵，且不做任何明示或暗示的担保，包括但不限于对适销性、适合某特定用途或不侵犯任何第三方知识产权的暗示担保。

所述资源可供专业开发人员应用TI 产品进行设计使用。您将对以下行为独自承担全部责任：(1) 针对您的应用选择合适的TI 产品；(2) 设计、验证并测试您的应用；(3) 确保您的应用满足相应标准以及任何其他安全、安保或其他要求。所述资源如有变更，恕不另行通知。TI 对您使用所述资源的授权仅限于开发资源所涉及TI 产品的相关应用。除此之外不得复制或展示所述资源，也不提供其它TI 或任何第三方的知识产权授权许可。如因使用所述资源而产生任何索赔、赔偿、成本、损失及债务等，TI 对此概不负责，并且您须赔偿由此对TI 及其代表造成的损害。

TI 所提供产品均受TI 的销售条款 (<http://www.ti.com.cn/zh-cn/legal/termsofsale.html>) 以及ti.com.cn上或随附TI产品提供的其他可适用条款的约束。TI提供所述资源并不扩展或以其他方式更改TI 针对TI 产品所发布的可适用的担保范围或担保免责声明。

邮寄地址：上海市浦东新区世纪大道 1568 号中建大厦 32 楼，邮政编码：200122

Copyright © 2020 德州仪器半导体技术（上海）有限公司