

## 采用 0402 封装的 TMP64 ±1% 47kΩ 线性热敏电阻

### 1 特性

- 具有正温度系数 (PTC) 的硅基热敏电阻
- 线性电阻随温度变化
- 在 25°C 下具有 47kΩ 标称电阻 (R25)
  - ±1% 最大值 (0°C 至 70°C)
- -40°C 至 +125°C 的宽工作温度范围
- 在整个温度范围内具有稳定的灵敏度
  - 6400ppm/°C TCR (25°C)
  - 在整个温度范围内具有 0.2% 的典型 TCR 容差
- 快速热响应时间为 0.6s (DEC)
- 长寿命和稳健性能
  - 内置失效防护，能够在发生短路故障时提供保护
  - 传感器长期温漂典型值为 0.5%

### 2 应用

- 温度监控
  - HVAC 和恒温器
  - 工业控制和电器
- 热补偿
  - 显示屏背光
  - 楼宇自动化
- 热阈值检测
  - 电机控制
  - 充电器

### 3 说明

立即开始使用[热敏电阻设计工具](#)，它提供了完整的电阻与温度关系表 (R-T 表) 的计算以及用于推导温度和示例 C 代码的有用方法。

线性热敏电阻可在整个温度范围内提供线性度和一致的灵敏度，支持使用简单而准确的方法进行温度转换。低功耗和较小的热质量可最大限度地减小自发热的影响。凭借内置的高温失效防护以及对环境变化的强大抵抗力，这类器件可长时间提供高性能。TMP6 系列器件外型小巧，可靠近热源放置，并具有快速响应时间。

与 NTC 热敏电阻相比，它具有以下优点：无需额外的线性化电路、最大程度减少校准工作量、电阻容差变化更小、高温下灵敏度更高以及可节省处理器时间和内存的简化转换方法。

TMP64 目前采用与 0402 封装外形兼容的 X1SON 封装。

器件信息(1)

器件型号	封装	封装尺寸 (标称值)
TMP64	X1SON	0.60mm x 1.00mm

(1) 如需了解所有可用封装，请参阅数据表末尾的可订购产品附录。

典型实施电路

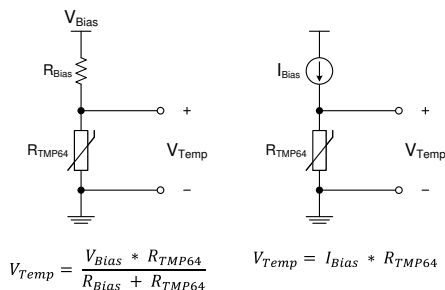

典型电阻与环境温度间的关系

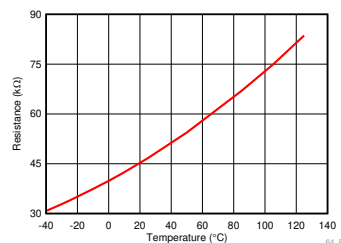

## 目录

1 特性 .....	1	7.4 Feature Description .....	9
2 应用 .....	1	7.5 Device Functional Modes .....	9
3 说明 .....	1	<b>8 Application and Implementation .....</b>	<b>10</b>
4 修订历史记录 .....	2	8.1 Application Information .....	10
<b>5 Pin Configuration and Functions .....</b>	<b>3</b>	8.2 Typical Application .....	10
<b>6 Specifications .....</b>	<b>4</b>	<b>9 Power Supply Recommendations .....</b>	<b>15</b>
6.1 Absolute Maximum Ratings .....	4	<b>10 Layout .....</b>	<b>15</b>
6.2 ESD Ratings .....	4	10.1 Layout Guidelines .....	15
6.3 Recommended Operating Conditions .....	4	10.2 Layout Example .....	15
6.4 Thermal Information .....	4	<b>11 器件和文档支持 .....</b>	<b>16</b>
6.5 Electrical Characteristics .....	5	11.1 接收文档更新通知 .....	16
6.6 Typical Characteristics .....	6	11.2 支持资源 .....	16
<b>7 Detailed Description .....</b>	<b>8</b>	11.3 商标 .....	16
7.1 Overview .....	8	11.4 静电放电警告 .....	16
7.2 Functional Block Diagram .....	8	11.5 Glossary .....	16
7.3 TMP64 R-T table .....	9	<b>12 机械、封装和可订购信息 .....</b>	<b>16</b>

## 4 修订历史记录

注：之前版本的页码可能与当前版本有所不同。

Changes from Revision Original (December 2019) to Revision A	Page
• 将数据表状态从“预告信息”更改为“生产数据” .....	1
• 更新了标题 .....	1
• 更新了 特性 .....	1
• 更新了 应用 .....	1
• 更新了 说明) .....	1
• Increased ESD CDM Rating from $\pm 750$ V to $\pm 1000$ V .....	4
• Changed minimum 'Long Term Drift' spec for RH = 85 % from 0.1 % to -1 % .....	5
• Added typical. 'Long Term Drift' spec for RH = 85 % .....	5
• Changed maximum 'Long Term Drift' spec for RH = 85 % from 0.8 % to 1 % .....	5
• Changed minimum 'Long Term Drift' spec from 0.1 % to -1% .....	5
• Added typical. 'Long Term Drift' spec .....	5
• Changed maximum 'Long Term Drift' spec from 1 % to 1.8 % .....	5
• Added 'Supply Dependence Resistance vs. Bias Current' graph .....	6
• Added 'Supply Dependence Resistance vs. Bias Voltage' graph .....	6
• Added 'Step Response' graph .....	6
• Added 'Thermal Response time' graphs .....	6
• Updated Thermistor Design Tool link .....	9

## 5 Pin Configuration and Functions

DEC Package  
2-Pin X1SON  
Top View (Angled)

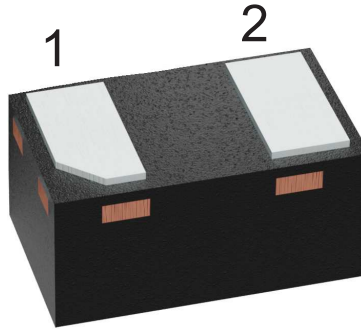

### Pin Functions

PIN		TYPE	DESCRIPTION
NAME	NO.		
-	1	—	Thermistor (-) and (+) terminals. For proper operation, ensure a positive bias where the + terminal is at a higher voltage potential than the - terminal.
+	2		

## 6 Specifications

### 6.1 Absolute Maximum Ratings

over operating free-air temperature range (unless otherwise noted) <sup>(1)</sup>

	MIN	MAX	UNIT
Voltage across pins 2 (+) and 1 (–)		+6	V
Current through the device		+450	μA
Junction temperature (T <sub>J</sub> )	–65	+150	°C
Storage temperature (T <sub>stg</sub> )	–65	+150	°C

- (1) Stresses beyond those listed under *Absolute Maximum Ratings* may cause permanent damage to the device. These are stress ratings only, which do not imply functional operation of the device at these or any other conditions beyond those indicated under *Recommended Operating Conditions*. Exposure to absolute-maximum-rated conditions for extended periods may affect device reliability.

### 6.2 ESD Ratings

			VALUE	UNIT
V <sub>(ESD)</sub>	Electrostatic discharge	Human-body model (HBM) per JESD22-A114 <sup>(1)</sup>	±2000	V
		Charged-device model (CDM), per JEDEC specification JESD22-C101 <sup>(2)</sup>	±1000	

- (1) JEDEC document JEP155 states that 500-V HBM allows safe manufacturing with a standard ESD control process.  
 (2) JEDEC document JEP157 states that 250-V CDM allows safe manufacturing with a standard ESD control process.

### 6.3 Recommended Operating Conditions

over operating free-air temperature range (unless otherwise noted)

		MIN	NOM	MAX	UNIT
V <sub>Sns</sub>	Voltage across pins 2 (+) and 1 (–)	0		5.5	V
I <sub>Sns</sub>	Current passing through the device	0		400	μA
T <sub>A</sub>	Operating free-air temperature (specified performance) (X1SON/DEC Package)	–40		125	°C

### 6.4 Thermal Information

THERMAL METRIC <sup>(1)</sup>		TMP64	Units
		DEC (X1SON)	
		2 PINS	
R <sub>θJA</sub>	Junction-to-ambient thermal resistance <sup>(2)(3)</sup>	443.4	°C/W
R <sub>θJC(top)</sub>	Junction-to-case (top) thermal resistance	195.7	°C/W
R <sub>θJB</sub>	Junction-to-board thermal resistance	254.6	°C/W
Ψ <sub>JT</sub>	Junction-to-top characterization parameter	19.9	°C/W
Ψ <sub>JB</sub>	Junction-to-board characterization parameter	254.5	°C/W
R <sub>θJC(bot)</sub>	Junction-to-case (bot) thermal resistance	–	°C/W

- (1) For more information about traditional and new thermal metrics, see the [Semiconductor and IC Package Thermal Metrics](#) application report.  
 (2) The junction to ambient thermal resistance (R<sub>θJA</sub>) under natural convection is obtained in a simulation on a JEDEC-standard, High-K board as specified in JESD51-7, in an environment described in JESD51-2. Exposed pad packages assume that thermal vias are included in the PCB, per JESD 51-5.  
 (3) Changes in output due to self heating can be computed by multiplying the internal dissipation by the thermal resistance.

## 6.5 Electrical Characteristics

 $T_A = -40\text{ }^\circ\text{C} - 125\text{ }^\circ\text{C}$ ,  $I_{Sns} = 42.553\text{ }\mu\text{A}$  (unless otherwise noted)

PARAMETER		TEST CONDITIONS	MIN	TYP	MAX	UNIT
$R_{25}$	Thermistor Resistance at 25 °C	$T_A = 25\text{ }^\circ\text{C}$	46.53	47	47.47	k $\Omega$
$R_{TOL}$	Resistance Tolerance	$T_A = 25\text{ }^\circ\text{C}$	-1		1	%
		$T_A = 0\text{ }^\circ\text{C} - 70\text{ }^\circ\text{C}$	-1		1	
		$T_A = -40\text{ }^\circ\text{C} - 125\text{ }^\circ\text{C}$	-1.5		1.5	
$TCR_{-35}$	Temperature Coefficient of Resistance	$T1 = -40\text{ }^\circ\text{C}$ , $T2 = -30\text{ }^\circ\text{C}$		+6220		ppm/ $^\circ\text{C}$
$TCR_{25}$		$T1 = 20\text{ }^\circ\text{C}$ , $T2 = 30\text{ }^\circ\text{C}$		+6400		
$TCR_{85}$		$T1 = 80\text{ }^\circ\text{C}$ , $T2 = 90\text{ }^\circ\text{C}$		+5910		
$TCR_{-35}\%$	Temperature Coefficient of Resistance Tolerance	$T1 = -40\text{ }^\circ\text{C}$ , $T2 = -30\text{ }^\circ\text{C}$		$\pm 0.4$		%
$TCR_{25}\%$		$T1 = 20\text{ }^\circ\text{C}$ , $T2 = 30\text{ }^\circ\text{C}$		$\pm 0.2$		
$TCR_{85}\%$		$T1 = 80\text{ }^\circ\text{C}$ , $T2 = 90\text{ }^\circ\text{C}$		$\pm 0.3$		
$\Delta R$	Sensor Long Term Drift (Reliability)	96 hours continuous operation at RH = 85% and $T_A = 130\text{ }^\circ\text{C}$ $V_{Bias} = 5.5\text{ V}$	-1	$\pm 0.1$	1	%
		600 hours continuous operation at $T_A = 150\text{ }^\circ\text{C}$ $V_{Bias} = 5.5\text{ V}$	-1	0.5	1.8	
$t_{RES}$ (stirred liquid)	Thermal response to 63%	$T1 = 25\text{ }^\circ\text{C}$ in Still Air to $T2 = 125\text{ }^\circ\text{C}$ in Stirred Liquid		0.6		s
$t_{RES}$ (still air)	Thermal response to 63%	$T1 = 25\text{ }^\circ\text{C}$ to $T2 = 70\text{ }^\circ\text{C}$ in Still Air		3.2		s

## 6.6 Typical Characteristics

at  $T_A = 25\text{ }^\circ\text{C}$ , (unless otherwise noted)



图 1. Resistance vs. Ambient Temperature Using Multiple Bias Currents



$R_{Bias} = 47\text{ k}\Omega$  with  $\pm 0.01\%$  Tolerance

图 2. Resistance vs. Ambient Temperature Using Multiple Bias Voltages

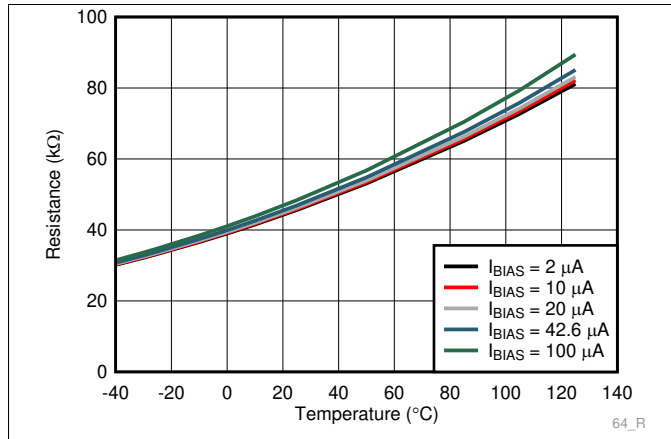
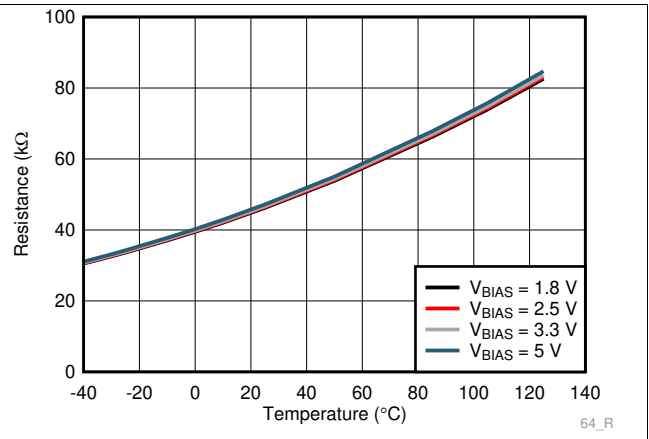

图 3. TCR as a Function of Sense Current,  $I_{SNS}$



$R_{Bias} = 47\text{ k}\Omega$  with  $\pm 0.01\%$  Tolerance

图 4. TCR as a Function of Sense Voltage,  $V_{SNS}$

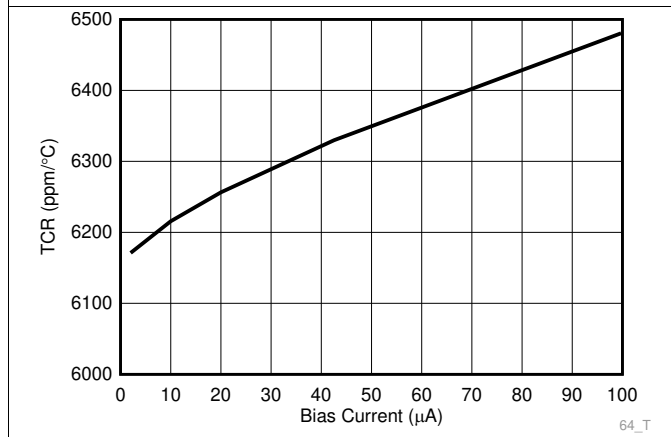
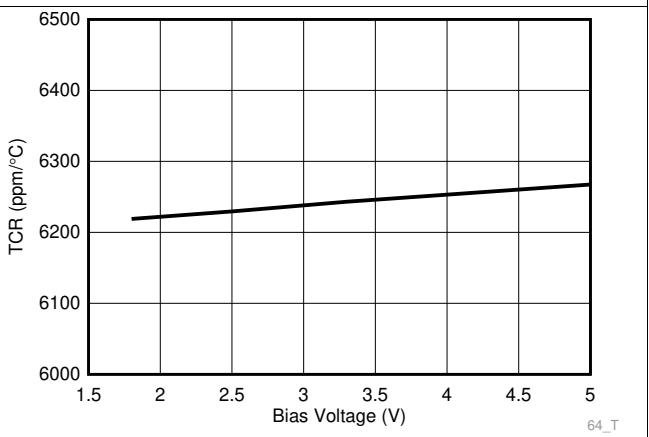

图 5. Supply Dependence Resistance vs. Bias Current



$R_{Bias} = 47\text{ k}\Omega$  with  $\pm 0.01\%$  Tolerance

图 6. Supply Dependence R vs.  $V_{Bias}$

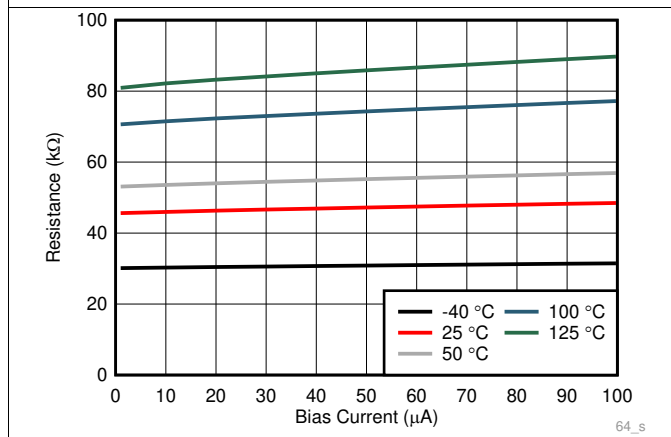
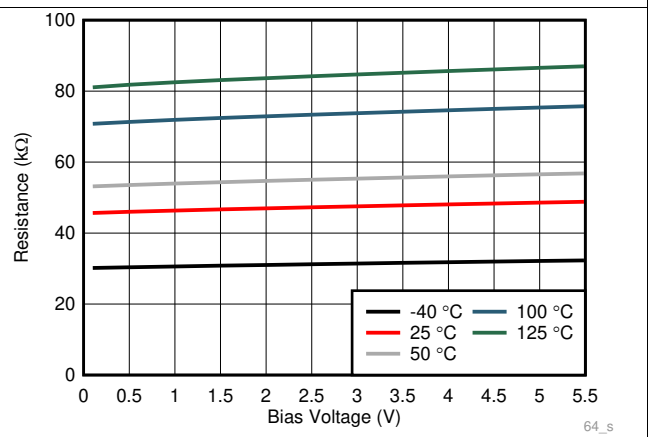
Typical Characteristics (接下页)

at  $T_A = 25\text{ }^\circ\text{C}$ , (unless otherwise noted)



图 7. Step Response

图 8. Thermal Response Time

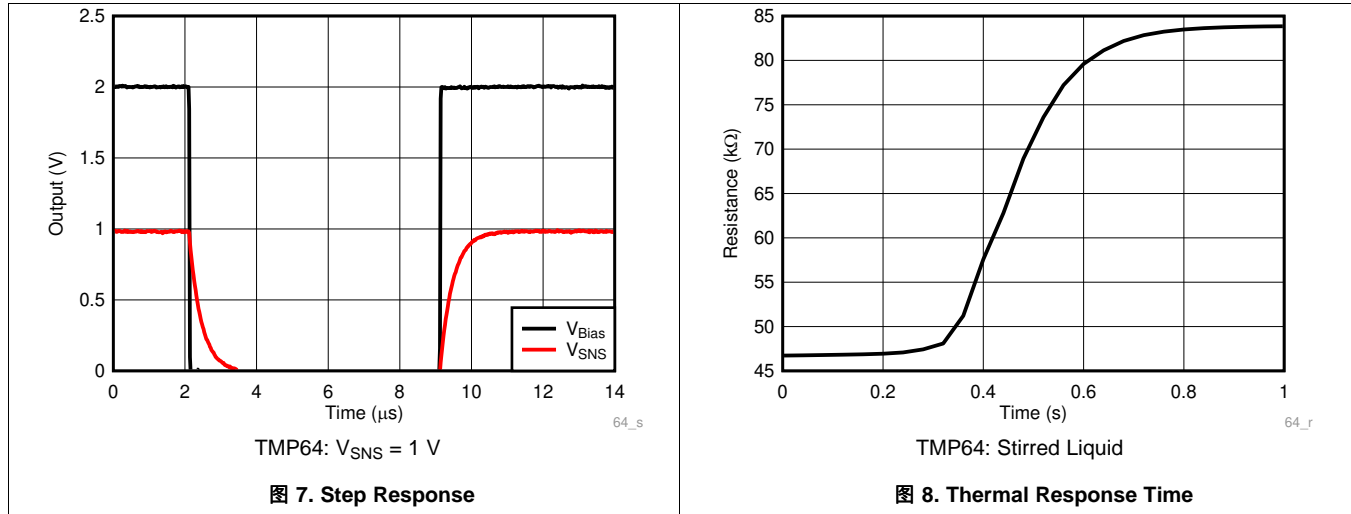

图 9. Thermal Response Time

## 7 Detailed Description

### 7.1 Overview

The TMP64 silicon linear thermistor has a linear positive temperature coefficient (PTC) that results in a uniform and consistent temperature coefficient resistance (TCR) across a wide operating temperature range. TI uses a special silicon process where the the doping level and active region areas devices control the key characteristics (the temperature coefficient resistance (TCR) and nominal resistance (R25)) . The device has an active area and a substrate due to the polarized terminals. Connect the positive terminal to the highest voltage potential. Connect the negative terminal to the lowest voltage potential.

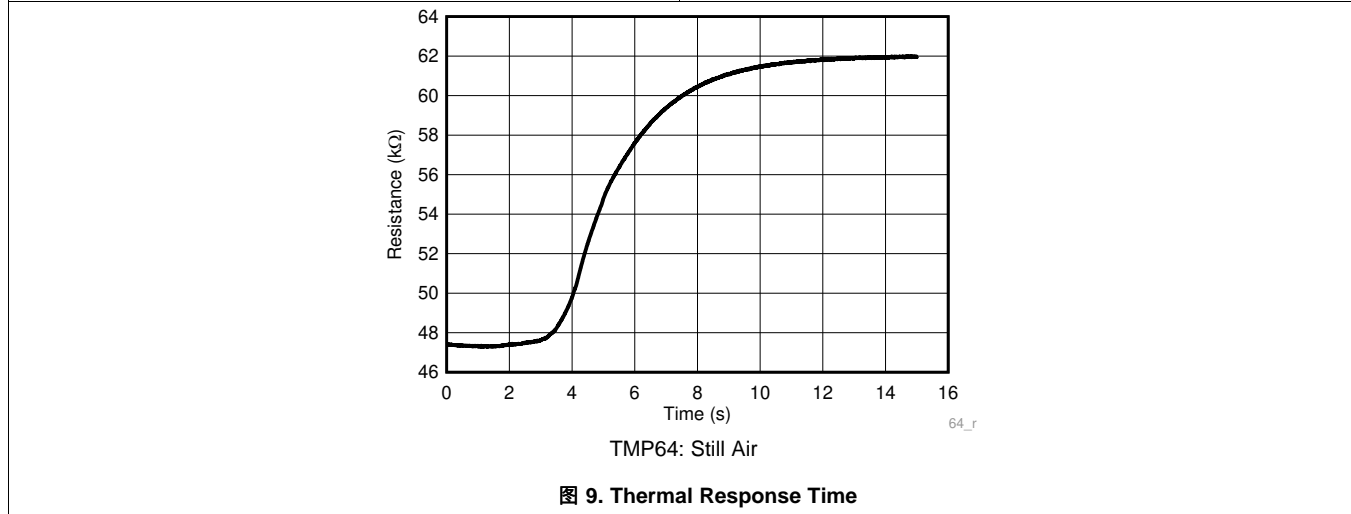
Unlike an NTC, which is a purely resistive device, the TMP64 resistance is affected by the current across the device and the resistance changes when the temperature changes. In a voltage divider circuit, it is recommended to maintain the top resistor value at 47 kΩ. Changing the top resistor value or the  $V_{BIAS}$  value changes the resistance vs temperature table (R-T table) of the TMP64, and subsequently the polynomials as described in [Design Requirements](#). Consult the [TMP64 R-T table](#) section for more information.

$$TCR \text{ (ppm/}^\circ\text{C)} = (R_{T2} - R_{T1}) / ((T_2 - T_1) \times R_{(T2+T1)/2}) \tag{1}$$

Below are the definitions of the key terms used throughout this document:

- $I_{SNS}$ : Current flowing through the TMP64.
- $V_{SNS}$ : Voltage across the two TMP64 terminals.
- $I_{Bias}$ : Current supplied by the biasing circuit.
- $V_{Bias}$ : Voltage supplied by the biasing circuit.
- $V_{Temp}$ : Output voltage that corresponds to the measured temperature. Note that this is different from  $V_{SNS}$ . In the use case of a voltage divider circuit with the TMP64 in the high side,  $V_{Temp}$  is taken across  $R_{Bias}$ .

### 7.2 Functional Block Diagram



图 10. Typical Implementation Circuits

### 7.3 TMP64 R-T table

The TMP64 R-T table must be re-calculated for any change in the bias voltage, bias resistor, or bias current. TI provides a [Thermistor Design Tool](#) to calculate the R-T table. The system designer should always validate the calculations provided.

## 7.4 Feature Description

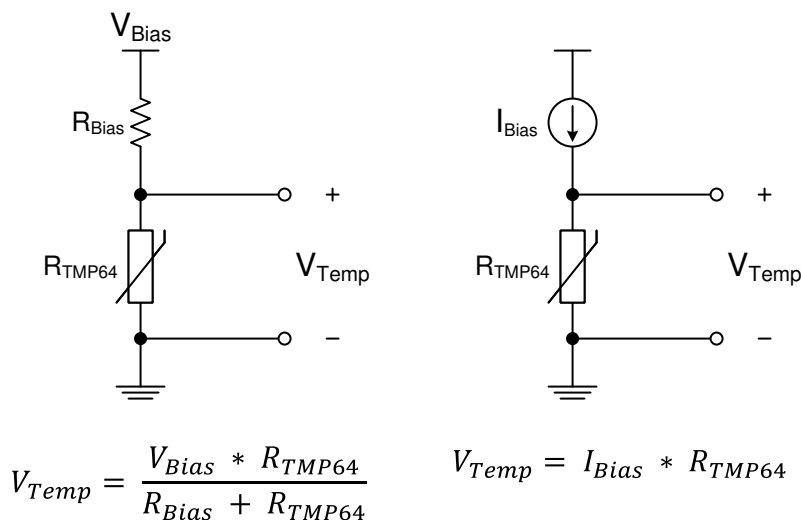
### 7.4.1 Linear resistance curve

The TMP64 has good linear behavior across the whole temperature range as shown in [Figure 1](#). This range allows a simpler resistance-to-temperature conversion method that reduces look-up table memory requirements. The linearization circuitry or midpoint calibration associated with traditional NTCs is not necessary with the device.

The linear resistance across the entire temperature range allows the device to maintain sensitivity at higher operating temperatures.

### 7.4.2 Positive Temperature Coefficient (PTC)

The TMP64 has a positive temperature coefficient. As temperature increases the device resistance increases leading to a reduction in power consumption of the bias circuit. In comparison, a negative coefficient system increases power consumption with temperature as the resistance decreases.

The TMP64 benefits from the reduced power consumption of the bias circuit with less self-heating than a typical NTC system.

## 7.5 Device Functional Modes

The device has one mode of operation that applies when operated within the [Recommended Operating Conditions](#).

## 8 Application and Implementation

### NOTE

Information in the following applications sections is not part of the TI component specification, and TI does not warrant its accuracy or completeness. TI's customers are responsible for determining suitability of components for their purposes. Customers should validate and test their design implementation to confirm system functionality.

### 8.1 Application Information

The TMP64 is a positive temperature coefficient (PTC) linear silicon thermistor. The device behaves like a temperature-dependent resistor, and may be configured in a variety of ways to monitor temperature based on the system-level requirements. The TMP64 has a nominal resistance at 25 °C ( $R_{25}$ ) of 47 k $\Omega$ , a maximum operating voltage of 5.5 V ( $V_{Sns}$ ), and maximum supply current of 400  $\mu$ A ( $I_{Sns}$ ). This device may be used in a variety of applications to monitor temperature close to a heat source with the very small DEC package option compatible with the typical 0402 (inch) footprint. Some of the factors that influence the total measurement error include the ADC resolution (if applicable), the tolerance of the bias current or voltage, the tolerance of the bias resistance in the case of a voltage divider configuration, and the location of the sensor with respect to the heat source.

### 8.2 Typical Application

#### 8.2.1 Thermistor Biasing Circuits

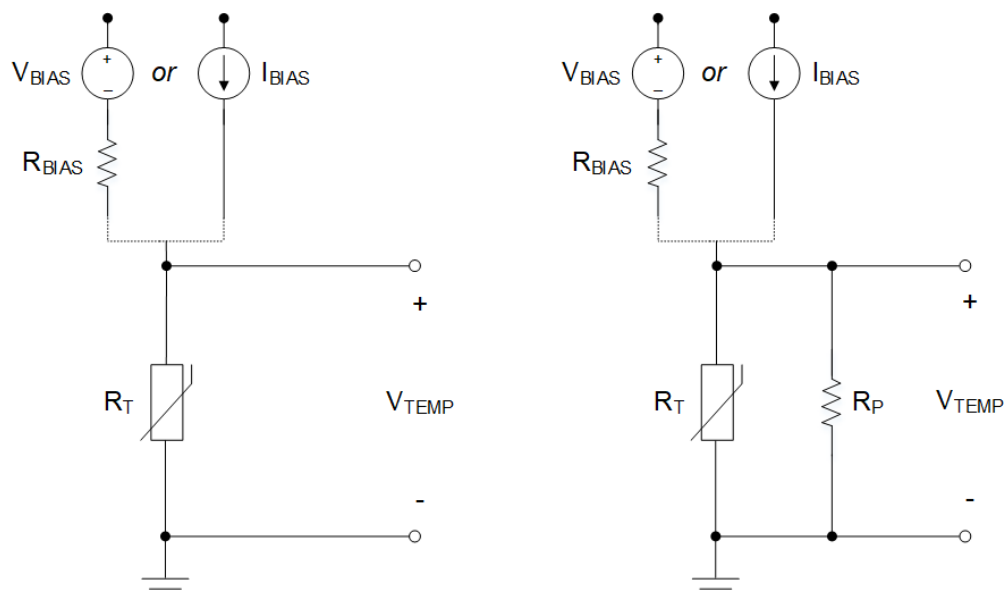

**Figure 11. Biasing Circuit Implementations With Linear Thermistor (Left) vs. Non-Linear Thermistor (Right)**

#### 8.2.1.1 Design Requirements

Existing thermistors, in general, have a non-linear temperature vs. resistance curve. To linearize the thermistor response, the engineer can use a voltage linearization circuit with a voltage divider configuration, or a resistance linearization circuit by adding another resistance in parallel with the thermistor,  $R_P$ . The [Thermistor Biasing Circuits](#) section highlights the two implementations where  $R_T$  is the thermistor resistance. To generate an output voltage across the thermistor, the engineer can use a voltage divider circuit with the thermistor placed at either the high side (close to supply) or low side (close to ground), depending on the desired voltage response (negative or positive). Alternatively, the thermistor can be biased directly using a precision current source

## Typical Application (continued)

(yielding the highest accuracy and voltage gain). It is common to use a voltage divider with thermistors because of its simple implementation and lower cost. The TMP64, on the other hand, has a linear positive temperature coefficient (PTC) of resistance such that the voltage measured across it increases linearly with temperature. As such, the need for a linearization circuits is no longer a requirement, and a simple current source or a voltage divider circuit can be used to generate the temperature voltage.

This output voltage can be interpreted using a comparator against a voltage reference to trigger a temperature trip point that is either tied directly to an ADC to monitor temperature across a wider range or used as feedback input for an active feedback control circuit.

The voltage across the TMP64, as described in Equation 2, can be translated to temperature using either a lookup table method (LUT) or a fitting polynomial,  $V(T)$ . The [Thermistor Design Tool](#) must be used to translate  $V_{temp}$  to Temperature. The temperature voltage must first be digitized using an ADC. The necessary resolution of this ADC is dependent on the biasing method used. Additionally, for best accuracy, the bias voltage ( $V_{BIAS}$ ) should be tied to the reference voltage of the ADC to create a measurement where the difference in tolerance between the bias voltage and the reference voltage cancels out. The engineer can also implement a low-pass filter to reject system level noise, and the user should place the filter as close to the ADC input as possible.

### 8.2.1.2 Detailed Design Procedure

The resistive circuit divider method produces an output voltage ( $V_{TEMP}$ ) scaled according to the bias voltage ( $V_{BIAS}$ ). When  $V_{BIAS}$  is also used as the reference voltage of the ADC, any fluctuations or tolerance error due to the voltage supply is canceled and does not affect the temperature accuracy. This type of configuration is shown in Figure 12. Equation 2 describes the output voltage ( $V_{TEMP}$ ) based on the variable resistance of the TMP64 ( $R_{TMP64}$ ) and bias resistor ( $R_{BIAS}$ ). The ADC code that corresponds to that output voltage, ADC full-scale range, and ADC resolution is given in Equation 3.

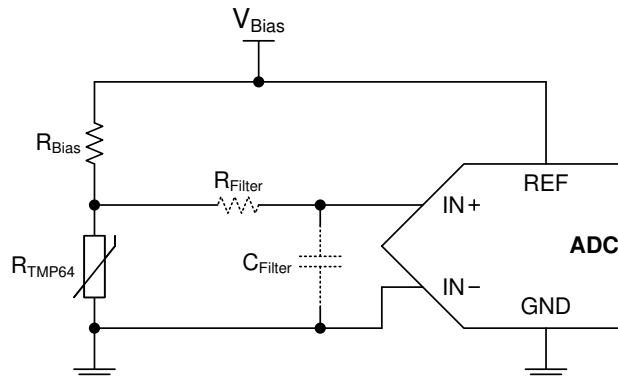

Figure 12. TMP64 Voltage Divider With an ADC

$$V_{TEMP} = V_{BIAS} \times \left( \frac{R_{TMP64}}{R_{BIAS} + R_{TMP64}} \right) \quad (2)$$

$$ADC \text{ Code} = \left( \frac{V_{TEMP}}{FSR} \right) \times 2^n$$

where

- FSR is the full-scale range of the ADC, which is the voltage at REF to GND ( $V_{REF}$ )
- $n$  is the resolution of the ADC

Equation 4 shows whenever  $V_{REF} = V_{BIAS}$ ,  $V_{BIAS}$  cancels out.

$$ADC \text{ Code} = \left( \frac{V_{BIAS} \times \left( \frac{R_{TMP64}}{R_{BIAS} + R_{TMP64}} \right)}{V_{BIAS}} \right) \times 2^n = \left( \frac{R_{TMP64}}{R_{BIAS} + R_{TMP64}} \right) \times 2^n \quad (4)$$

## Typical Application (continued)

The engineer can use a polynomial equation or a LUT to extract the temperature reading based on the ADC code read in the microcontroller. The [Thermistor Design Tool](#) should be used to translate the TMP64 resistance to temperature.

The cancellation of  $V_{BIAS}$  is one benefit to using a voltage-divider (ratiometric approach), but the sensitivity of the output voltage of the divider circuit cannot increase much. Therefore, not all of the ADC codes are used due to the small voltage output range compared to the FSR. This application is very common, however, and is simple to implement.

The engineer can use a current source-based circuit, like the one shown in [Figure 13](#), to have better control over the sensitivity of the output voltage and achieve higher accuracy. In this case, the output voltage is simply  $V = I \times R$ . For example, if a current source of  $100 \mu A$  is used with the TMP64, the output voltage spans approximately 5.5 V and has a gain up to  $40 \text{ mV}/^\circ\text{C}$ . Having control over the voltage range and sensitivity allows for full utilization of the ADC codes and full-scale range. Similar to the ratiometric approach above, if the ADC has a built-in current source that shares the same bias as the reference voltage of the ADC, the tolerance of the supply current cancels out. In this case, a precision ADC is not required. This method yields the best accuracy, but can increase the system implementation cost.

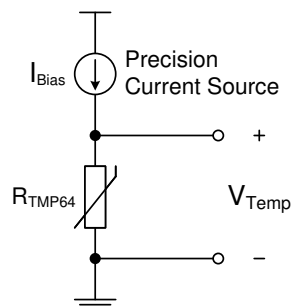

**Figure 13. TMP64 Biasing Circuit With Current Source**

In comparison to the non-linear NTC thermistor in a voltage divider, the TMP64 has an enhanced linear output characteristic. The two voltage divider circuits with and without a linearization parallel resistor,  $R_P$ , are shown in [Figure 14](#). Consider an example where  $V_{BIAS} = 5 \text{ V}$ ,  $R_{BIAS} = 47 \text{ k}\Omega$ , and a parallel resistor ( $R_P$ ) is used with the NTC thermistor ( $R_{NTC}$ ) to linearize the output voltage with an additional  $47\text{-k}\Omega$  resistor. The TMP64 produces a linear curve across the entire temperature range while the NTC curve is only linear across a small temperature region. When the parallel resistor ( $R_P$ ) is added to the NTC circuit, the added resistor makes the curve much more linear but greatly affects the output voltage range.

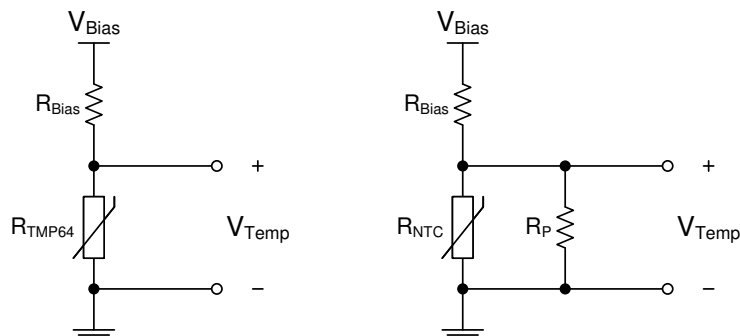
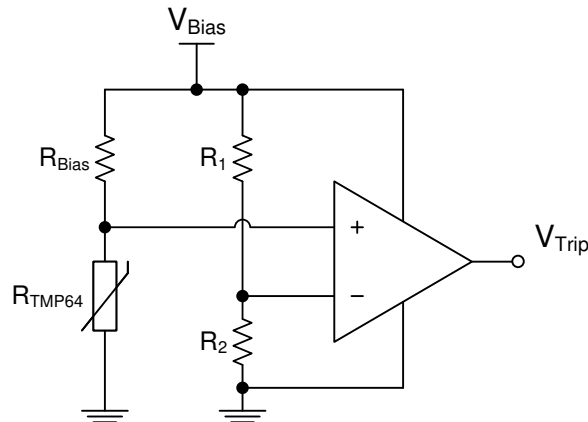

**Figure 14. TMP64 vs. NTC With Linearization Resistor ( $R_P$ ) Voltage Divider Circuits**

## Typical Application (continued)

### 8.2.1.2.1 Thermal Protection With Comparator

The engineer can use the TMP64, a voltage reference, and a comparator to program the thermal protection. As shown in Figure 15, the output of the comparator remains low until the voltage of the thermistor divider, with  $R_{BIAS}$  and  $R_{TMP64}$ , rises above the threshold voltage set by  $R_1$  and  $R_2$ . When the output goes high, the comparator signals an overtemperature warning signal. The engineer can also program the hysteresis to prevent the output from continuously toggling around the temperature threshold when the output returns low. Either a comparator with built-in hysteresis or feedback resistors may be used.



**Figure 15. Temperature Switch Using TMP64 Voltage Divider and a Comparator**

### 8.2.1.2.2 Thermal Foldback

One application that uses the output voltage of the TMP64 in an active control circuit is thermal foldback. This is performed to reduce, or fold back, the current driving a string of LEDs, for example. At high temperatures, the LEDs begin to heat up due to environmental conditions and self heating. Thus, at a certain temperature threshold based on the LED's safe operating area, the driving current must be reduced to cool down the LEDs and prevent thermal runaway. The TMP64 voltage output increases with temperature when the output is in the lower position of the voltage divider and can provide a response used to fold back the current. Typically, the current is held at a specified level until a high temperature is reached, known as the knee point, where the current must be rapidly reduced. To better control the temperature/voltage sensitivity of the TMP64, a rail-to-rail operational amplifier is used. In the example shown in Figure 16, the temperature "knee" where the foldback begins is set by the reference voltage (2.5 V) at the positive input, and the feedback resistors set the response of the foldback curve. The foldback knee point may be chosen based on the output of the voltage divider and the corresponding temperature from Equation 5 (like 110 °C, for example). A buffer is used in-between the voltage divider with  $R_{TMP64}$  and the input to the op amp to prevent loading and variations in  $V_{TEMP}$ .

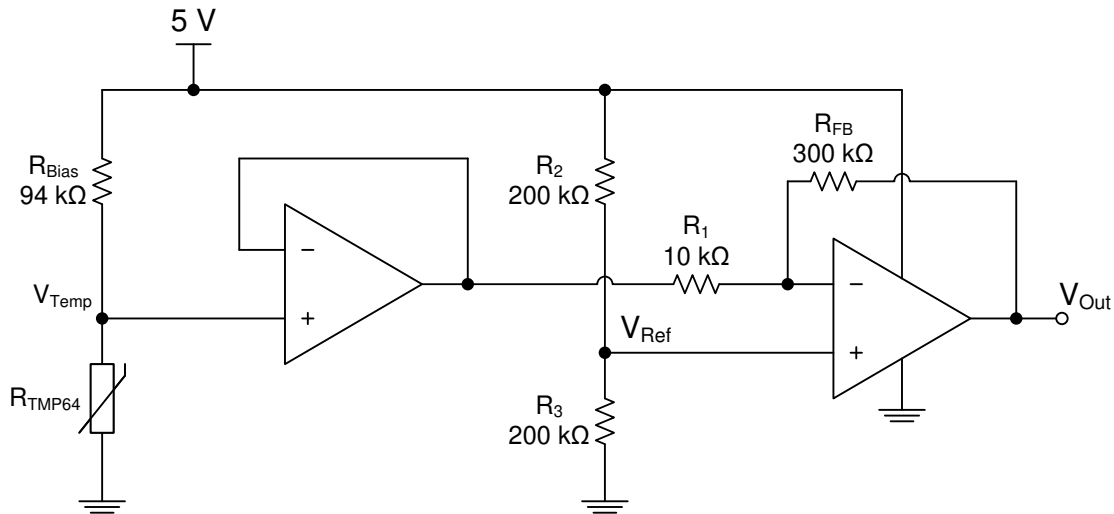
**Typical Application (continued)**

**Figure 16. Thermal Foldback Using TMP64 Voltage Divider and a Rail-to-Rail Op Amp**

The op amp remains high as long as the voltage output is below  $V_{Ref}$ . When the temperature goes above 110 °C, then the output swings low to the 0-V rail of the op amp. The rate at which the foldback occurs is dependent on the feedback network,  $R_{FB}$  and  $R_1$ , which varies the gain of the op amp,  $G$ , given by Equation 6. This in return controls the voltage/temperature sensitivity of the circuit. This voltage output is fed into a LED driver IC that adjusts output current accordingly. The final output voltage used for thermal foldback is  $V_{OUT}$ , and is given in Equation 7. In this example where the knee point is set at 110 °C, the output voltage curve is as shown in Figure 17.

$$V_{TEMP} = V_{BIAS} \times \left( \frac{R_{TMP64}}{R_{BIAS} + R_{TMP64}} \right) \quad (5)$$

$$G = \frac{R_{FB}}{R_1} \quad (6)$$

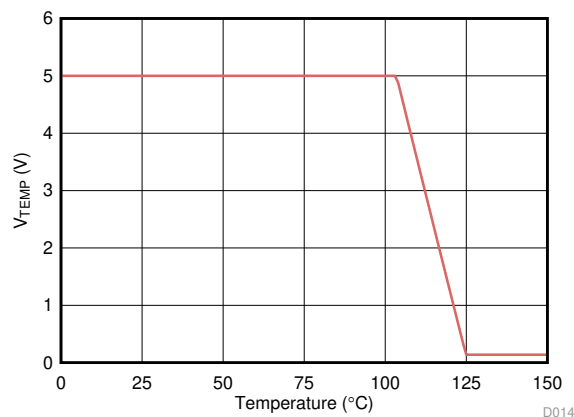
$$V_{OUT} = -G \times V_{TEMP} + (1 + G) \times V_{REF} \quad (7)$$

**Figure 17. Thermal Foldback Voltage Output Curve**

## 9 Power Supply Recommendations

The maximum recommended operating voltage of the TMP64 is 5.5 V ( $V_{Sns}$ ), and the maximum current through the device is 400  $\mu$ A ( $I_{Sns}$ ).

## 10 Layout

### 10.1 Layout Guidelines

The layout of the TMP64 is similar to that of a passive component. If the device is biased with a current source, the positive pin 2 is connected to the source, while the negative pin 1 is connected to ground. If the circuit is biased with a voltage source, and the device is placed on the lower side of the resistor divider,  $V-$  is connected to ground, and  $V+$  is connected to the output ( $V_{TEMP}$ ). If the device is placed on the upper side of the divider,  $V+$  is connected to the voltage source and  $V-$  is connected to the output voltage ( $V_{TEMP}$ ). [Figure 18](#) shows the device layout.

### 10.2 Layout Example

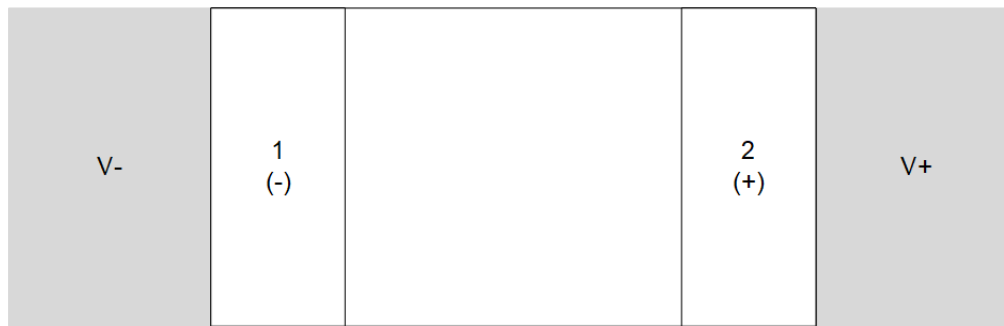

**Figure 18. Recommended Layout: DEC Package**

## 11 器件和文档支持

### 11.1 接收文档更新通知

要接收文档更新通知，请导航至 [ti.com.cn](http://ti.com.cn) 上的器件产品文件夹。单击右上角的通知我进行注册，即可每周接收产品信息更改摘要。有关更改的详细信息，请查看任何已修订文档中包含的修订历史记录。

### 11.2 支持资源

TI E2E™ [support forums](#) are an engineer's go-to source for fast, verified answers and design help — straight from the experts. Search existing answers or ask your own question to get the quick design help you need.

Linked content is provided "AS IS" by the respective contributors. They do not constitute TI specifications and do not necessarily reflect TI's views; see TI's [Terms of Use](#).

### 11.3 商标

E2E is a trademark of Texas Instruments.

All other trademarks are the property of their respective owners.

### 11.4 静电放电警告



ESD 可能会损坏该集成电路。德州仪器 (TI) 建议通过适当的预防措施处理所有集成电路。如果不遵守正确的处理措施和安装程序，可能会损坏集成电路。

ESD 的损坏小至导致微小的性能降级，大至整个器件故障。精密的集成电路可能更容易受到损坏，这是因为非常细微的参数更改都可能会导致器件与其发布的规格不相符。

### 11.5 Glossary

[SLYZ022](#) — *TI Glossary*.

This glossary lists and explains terms, acronyms, and definitions.

## 12 机械、封装和可订购信息

以下页面包含机械、封装和可订购信息。这些信息是指定器件的最新可用数据。数据如有变更，恕不另行通知，且不会对此文档进行修订。如需获取此数据表的浏览器版本，请查阅左侧的导航栏。

**PACKAGING INFORMATION**

Orderable Device	Status (1)	Package Type	Package Drawing	Pins	Package Qty	Eco Plan (2)	Lead finish/ Ball material (6)	MSL Peak Temp (3)	Op Temp (°C)	Device Marking (4/5)	Samples
TMP6431DECR	ACTIVE	X1SON	DEC	2	10000	RoHS & Green	NIPDAU	Level-1-260C-UNLIM	-40 to 125	HJ	<a href="#">Samples</a>
TMP6431DECT	ACTIVE	X1SON	DEC	2	250	RoHS & Green	NIPDAU	Level-1-260C-UNLIM	-40 to 125	HJ	<a href="#">Samples</a>
TMP6431DYAR	ACTIVE	SOT-5X3	DYA	2	3000	RoHS & Green	SN	Level-3-260C-168 HR	-40 to 150	1HH	<a href="#">Samples</a>
TMP6431DYAT	ACTIVE	SOT-5X3	DYA	2	250	RoHS & Green	SN	Level-3-260C-168 HR	-40 to 150	1HH	<a href="#">Samples</a>

(1) The marketing status values are defined as follows:

**ACTIVE:** Product device recommended for new designs.

**LIFEBUY:** TI has announced that the device will be discontinued, and a lifetime-buy period is in effect.

**NRND:** Not recommended for new designs. Device is in production to support existing customers, but TI does not recommend using this part in a new design.

**PREVIEW:** Device has been announced but is not in production. Samples may or may not be available.

**OBSOLETE:** TI has discontinued the production of the device.

(2) **RoHS:** TI defines "RoHS" to mean semiconductor products that are compliant with the current EU RoHS requirements for all 10 RoHS substances, including the requirement that RoHS substance do not exceed 0.1% by weight in homogeneous materials. Where designed to be soldered at high temperatures, "RoHS" products are suitable for use in specified lead-free processes. TI may reference these types of products as "Pb-Free".

**RoHS Exempt:** TI defines "RoHS Exempt" to mean products that contain lead but are compliant with EU RoHS pursuant to a specific EU RoHS exemption.

**Green:** TI defines "Green" to mean the content of Chlorine (Cl) and Bromine (Br) based flame retardants meet JS709B low halogen requirements of <=1000ppm threshold. Antimony trioxide based flame retardants must also meet the <=1000ppm threshold requirement.

(3) MSL, Peak Temp. - The Moisture Sensitivity Level rating according to the JEDEC industry standard classifications, and peak solder temperature.

(4) There may be additional marking, which relates to the logo, the lot trace code information, or the environmental category on the device.

(5) Multiple Device Markings will be inside parentheses. Only one Device Marking contained in parentheses and separated by a "-" will appear on a device. If a line is indented then it is a continuation of the previous line and the two combined represent the entire Device Marking for that device.

(6) Lead finish/Ball material - Orderable Devices may have multiple material finish options. Finish options are separated by a vertical ruled line. Lead finish/Ball material values may wrap to two lines if the finish value exceeds the maximum column width.

**Important Information and Disclaimer:**The information provided on this page represents TI's knowledge and belief as of the date that it is provided. TI bases its knowledge and belief on information provided by third parties, and makes no representation or warranty as to the accuracy of such information. Efforts are underway to better integrate information from third parties. TI has taken and

continues to take reasonable steps to provide representative and accurate information but may not have conducted destructive testing or chemical analysis on incoming materials and chemicals. TI and TI suppliers consider certain information to be proprietary, and thus CAS numbers and other limited information may not be available for release.

In no event shall TI's liability arising out of such information exceed the total purchase price of the TI part(s) at issue in this document sold by TI to Customer on an annual basis.

**TAPE AND REEL INFORMATION**

**QUADRANT ASSIGNMENTS FOR PIN 1 ORIENTATION IN TAPE**



\*All dimensions are nominal

Device	Package Type	Package Drawing	Pins	SPQ	Reel Diameter (mm)	Reel Width W1 (mm)	A0 (mm)	B0 (mm)	K0 (mm)	P1 (mm)	W (mm)	Pin1 Quadrant
TMP6431DECR	X1SON	DEC	2	10000	178.0	8.4	0.7	1.15	0.47	2.0	8.0	Q1
TMP6431DECT	X1SON	DEC	2	250	178.0	8.4	0.7	1.15	0.47	2.0	8.0	Q1
TMP6431DYAR	SOT-5X3	DYA	2	3000	178.0	9.5	0.5	1.94	0.73	4.0	8.0	Q1
TMP6431DYAT	SOT-5X3	DYA	2	250	178.0	9.5	0.5	1.94	0.73	4.0	8.0	Q1

**TAPE AND REEL BOX DIMENSIONS**

\*All dimensions are nominal

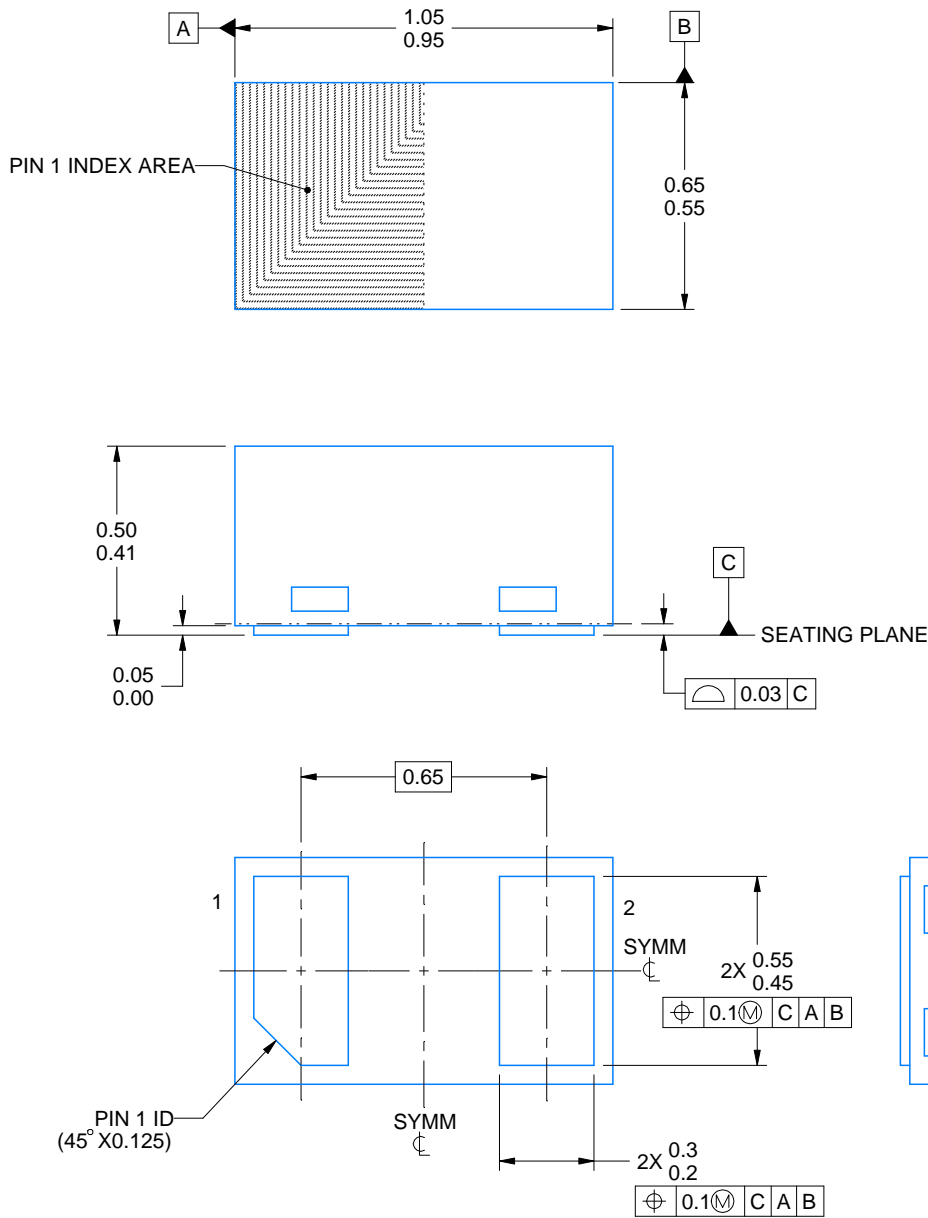
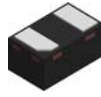
Device	Package Type	Package Drawing	Pins	SPQ	Length (mm)	Width (mm)	Height (mm)
TMP6431DECR	X1SON	DEC	2	10000	205.0	200.0	33.0
TMP6431DECT	X1SON	DEC	2	250	205.0	200.0	33.0
TMP6431DYAR	SOT-5X3	DYA	2	3000	210.0	200.0	42.0
TMP6431DYAT	SOT-5X3	DYA	2	250	210.0	200.0	42.0



4224506/A 08/2018

NOTES:

1. All linear dimensions are in millimeters. Any dimensions in parenthesis are for reference only. Dimensioning and tolerancing per ASME Y14.5M
2. This drawing is subject to change without notice.

# EXAMPLE BOARD LAYOUT

DEC0002A

X1SON - 0.5 mm max height

PLASTIC SMALL OUTLINE - NO LEAD

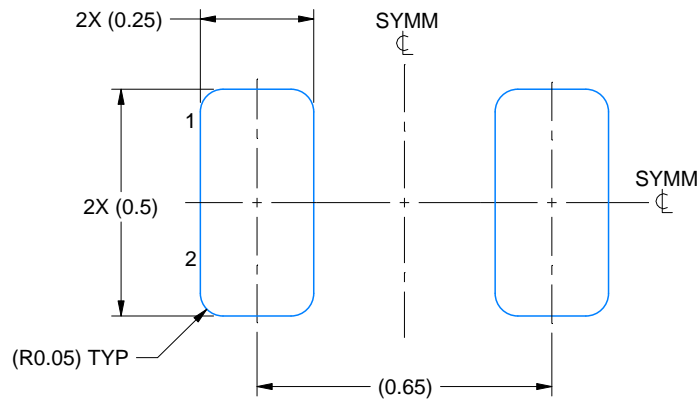

LAND PATTERN EXAMPLE  
EXPOSED METAL SHOWN  
SCALE:60X

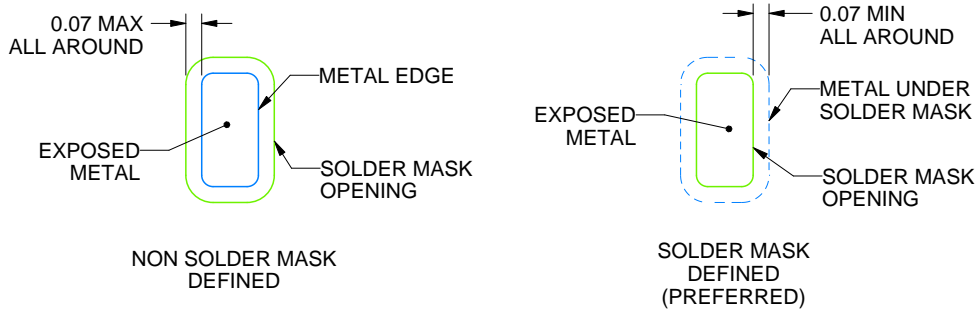

SOLDER MASK DETAILS

4224506/A 08/2018

NOTES: (continued)

3. For more information, see Texas Instruments literature number SLUA271 ([www.ti.com/lit/slue271](http://www.ti.com/lit/slue271)).
4. Vias are optional depending on application, refer to device data sheet. If any vias are implemented, refer to their locations shown on this view. It is recommended that vias under paste be filled, plugged or tented.

# EXAMPLE STENCIL DESIGN

DEC0002A

X1SON - 0.5 mm max height

PLASTIC SMALL OUTLINE - NO LEAD

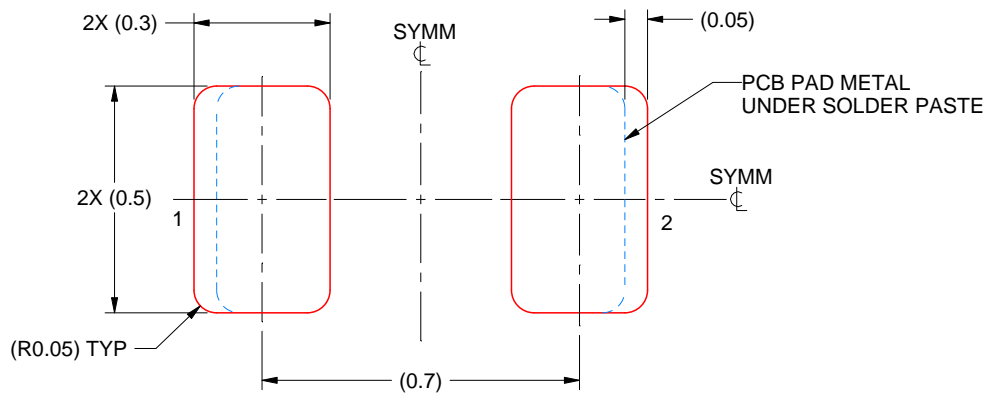

SOLDER PASTE EXAMPLE  
BASED ON 0.1 mm THICK STENCIL  
SCALE:60X

4224506/A 08/2018

NOTES: (continued)

5. Laser cutting apertures with trapezoidal walls and rounded corners may offer better paste release. IPC-7525 may have alternate design recommendations.



# EXAMPLE BOARD LAYOUT

DYA0002A

SOT (SOD-523) - 0.77 mm max height

PLASTIC SMALL OUTLINE

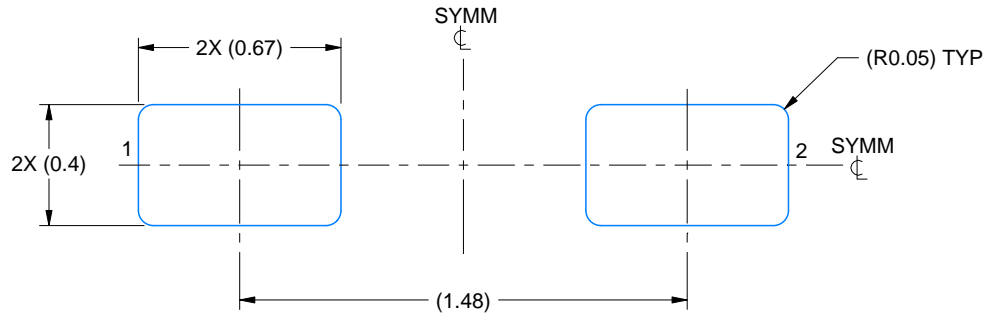

LAND PATTERN EXAMPLE  
SCALE:40X

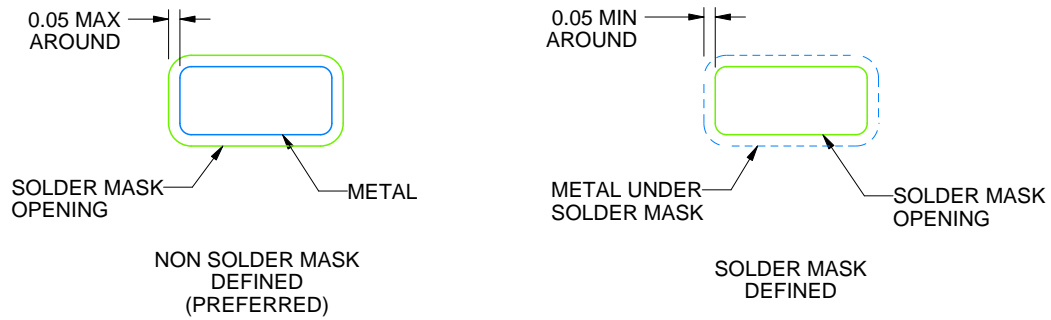

SOLDEMASK DETAILS

4224978/B 09/2021

NOTES: (continued)

- 5. Publication IPC-7351 may have alternate designs.
- 6. Solder mask tolerances between and around signal pads can vary based on board fabrication site.

# EXAMPLE STENCIL DESIGN

DYA0002A

SOT (SOD-523) - 0.77 mm max height

PLASTIC SMALL OUTLINE

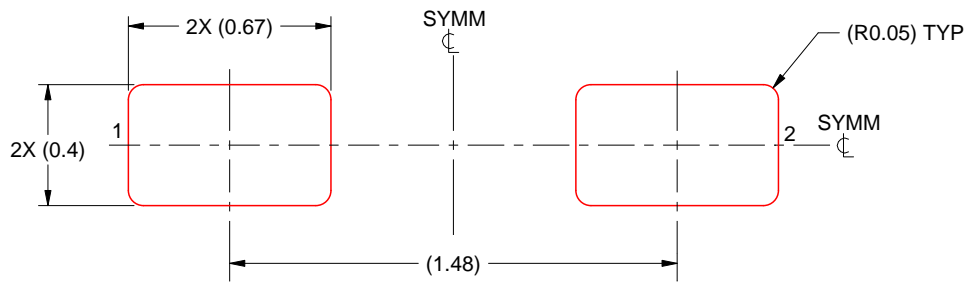

SOLDER PASTE EXAMPLE  
BASED ON 0.1 mm THICK STENCIL  
SCALE:40X

4224978/B 09/2021

NOTES: (continued)

7. Laser cutting apertures with trapezoidal walls and rounded corners may offer better paste release. IPC-7525 may have alternate design recommendations.
8. Board assembly site may have different recommendations for stencil design.

## 重要声明和免责声明

TI 提供技术和可靠性数据（包括数据表）、设计资源（包括参考设计）、应用或其他设计建议、网络工具、安全信息和其他资源，不保证没有瑕疵且不做任何明示或暗示的担保，包括但不限于对适销性、某特定用途方面的适用性或不侵犯任何第三方知识产权的暗示担保。

这些资源可供使用 TI 产品进行设计的熟练开发人员使用。您将自行承担以下全部责任：(1) 针对您的应用选择合适的 TI 产品，(2) 设计、验证并测试您的应用，(3) 确保您的应用满足相应标准以及任何其他安全、安保或其他要求。这些资源如有变更，恕不另行通知。TI 授权您仅可将这些资源用于研发本资源所述的 TI 产品的应用。严禁对这些资源进行其他复制或展示。您无权使用任何其他 TI 知识产权或任何第三方知识产权。您应全额赔偿因在这些资源的使用中对 TI 及其代表造成的任何索赔、损害、成本、损失和债务，TI 对此概不负责。

TI 提供的产品受 TI 的销售条款 (<https://www.ti.com.cn/zh-cn/legal/termsofsale.html>) 或 [ti.com.cn](https://www.ti.com.cn) 上其他适用条款/TI 产品随附的其他适用条款的约束。TI 提供这些资源并不会扩展或以其他方式更改 TI 针对 TI 产品发布的适用的担保或担保免责声明。

邮寄地址：上海市浦东新区世纪大道 1568 号中建大厦 32 楼，邮政编码：200122

Copyright © 2021 德州仪器半导体技术（上海）有限公司