

3.3V 至 18V Thunderbolt 电源多路复用器

 查询样品: [TPS22981](#)

特性

- 3.3V 电源供电
- 4.5V 至 19.8V 高电压开关
- 3V 至 3.6V 开关
- 可调节限流
- 热关断
- 先合后断开关
- 低电压闭合之前的高电压放电
- 反向电流阻断

应用范围

- 笔记本电脑
- 台式机
- 电源管理系统

说明

TPS22981 是一款限流型电源多路复用器，此器件可从一个低电压电源（3V 到 3.6V）或者一个高电压电源（4.5V 到 19.8V）提供到一个外设的连接。由数字控制信号选择所需的输出。

高电压 (VHV) 和低电压 (V3P3) 开关电流限值由外部电阻设定。一旦达到电流限值，TPS22981 将会控制此开关以保持此电流限值。

当此高电压电源不在时，TPS22981 将保持到低电压电源输出的连接。高电压线路和高压使能信号出现时，此高压开关将会与低电压开关一同打开，直到在低压开关上检测到一个反向电流，从而实现最小下降电流和击穿电流情况下的低压电源至高压电源的无缝转换。

为了避免 VHV 连接到 V3P3 连接切换期间的电流回流，TPS22981 将会中断 VHV 连接，将此输出放电至 3.3V，然后连接至 V3P3。当负载出现时，在返回 3.3V 之前，此输出将转变到 0V。

TPS22981 采用 4mm x 4mm x 1mm 四方扁平无引线 (QFN) 封装。



图 1. 典型应用



Please be aware that an important notice concerning availability, standard warranty, and use in critical applications of Texas Instruments semiconductor products and disclaimers thereto appears at the end of this data sheet.

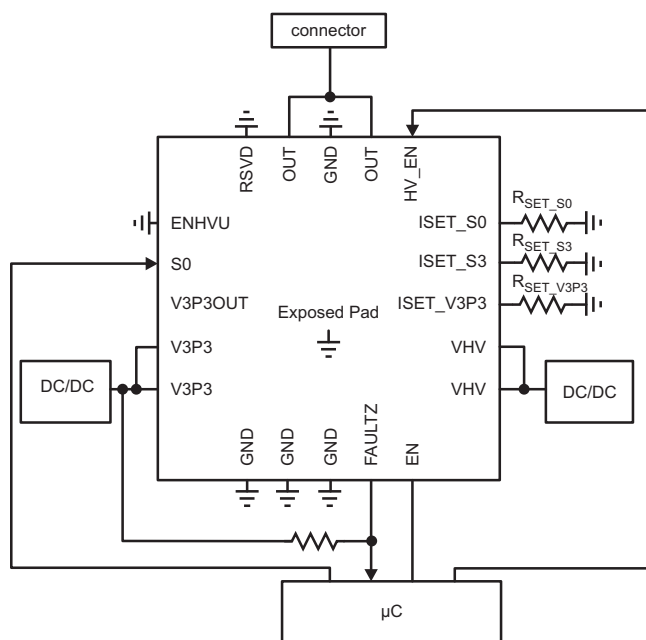

These devices have limited built-in ESD protection. The leads should be shorted together or the device placed in conductive foam during storage or handling to prevent electrostatic damage to the MOS gates.

ORDERING INFORMATION

PART NUMBER	PACKAGE MARKING	PACKAGE	DEVICE SPECIFIC FEATURES
TPS22981RGPR	PS22981	RGP	Tape and Reel

Top View/Footprint

Bottom View

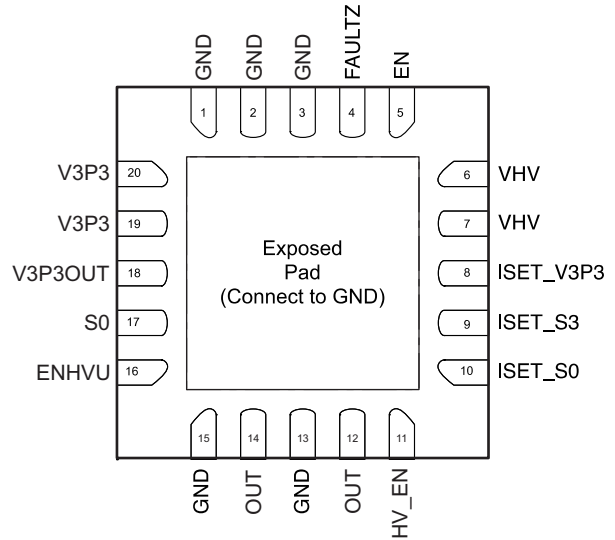
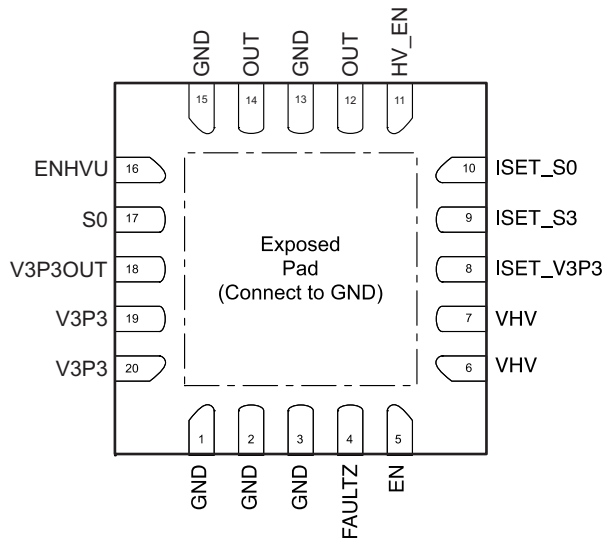

Package Size: 4mm x 4mm x 1mm height
 Pad Pitch: 0.5mm

DISSIPATION RATINGS

PACKAGE	THERMAL RESISTANCE ⁽¹⁾ θ_{JA}	POWER RATING ⁽¹⁾ $T_A = 25^\circ\text{C}$	POWER RATING ⁽¹⁾ $T_A = 70^\circ\text{C}$	DERATING FACTOR ABOVE ⁽²⁾ $T_A = 25^\circ\text{C}$
RGP	39.3°C/W	2.16W	1.02W	25.4mW/°C

(1) Simulated with high-K board

(2) Maximum power dissipation is a function of $T_{J(max)}$, θ_{JA} and T_A . The maximum allowable power dissipation at any allowable ambient temperature is $P_D = (T_{J(max)} - T_A) / \theta_{JA}$.

ABSOLUTE MAXIMUM RATINGS

over operating free-air temperature range (unless otherwise noted)⁽¹⁾

		VALUE	UNIT
V _I	Input voltage range on V3P3 (VDD) ⁽²⁾	–0.3 to 3.6	V
	Input voltage range on EN, HV_EN, ENHVU, ISET_V3P3, ISET_S0, ISET_S3, S0 ⁽²⁾	–0.3 to V3P3+0.3	
	Output voltage range on FAULTZ	–0.3 to V3P3+0.3	
	Input voltage range on VHV ⁽²⁾	–0.3 to 20	
	Output voltage range at OUT ⁽²⁾	–0.3 to 20	
	Voltage range between VHV and OUT (V _{VHV} –V _{OUT})	–7 to 20	
	Output voltage range at V3P3OUT ⁽²⁾	–0.3 to V3P3+0.3	
T _A	Operating ambient temperature range ⁽³⁾	–40 to 85	°C
T _{J (MAX)}	Maximum operating junction temperature	110	°C
T _{stg}	Storage temperature range	–65 to 150	°C
ESD Rating	Charge Device Model (JESD 22 C101)	500	V
	Human Body Model (JESD 22 A114)	2	kV

- (1) Stresses beyond those listed under absolute maximum ratings may cause permanent damage to the device. These are stress ratings only, and functional operation of the device at these or any other conditions beyond those indicated under recommended operating conditions is not implied. Exposure to absolute–maximum–rated conditions for extended periods may affect device reliability.
- (2) All voltage values are with respect to network ground terminal.
- (3) In applications where high power dissipation and/or poor package thermal resistance is present, the maximum ambient temperature may have to be derated. Maximum ambient temperature [TA(max)] is dependent on the maximum operating junction temperature [TJ(max)], the maximum power dissipation of the device in the application [PD(max)], and the junction-to-ambient thermal resistance of the part/package in the application (MJA), as given by the following equation: TA(max) = TJ(max) – (MJA × PD(max))

RECOMMENDED OPERATING CONDITIONS

over operating free-air temperature range (unless otherwise noted)

			MIN	MAX	UNIT
V _{3P3}	Supply voltage range		3	3.6	V
V _{HV}			4.5	19.8	V
I _{LIM3P3OUT}	V3P3OUT Switch current range		0	500	mA
V _{IH}	Input logic high	EN, HV_EN, ENHVU, S0	V3P3-0.6	V3P3	V
V _{IL}	Input logic low	EN, HV_EN, ENHVU, S0	0	0.6	V
R _{SET_V3P3}	3.3V switch current limit set resistance		26.7	402	kΩ
R _{SET_S0}	VHV switch current limit in S0 mode set resistance		26.7	402	kΩ
R _{SET_S3}	VHV switch current limit in S3 mode set resistance		26.7	402	kΩ
R _{FAULTZ}	FAULTZ pull-up resistance to V3P3		30		kΩ

ELECTRICAL CHARACTERISTICS

Unless otherwise noted the specification applies over the V_{DD} range and operating junction temp $-40^{\circ}\text{C} \leq T_J \leq 85^{\circ}\text{C}$. Typical values are for $V_{3P3} = 3.3\text{V}$, $V_{HV} = 15\text{V}$, and $T_J = 25^{\circ}\text{C}$.

PARAMETER		TEST CONDITIONS	MIN	TYP	MAX	UNIT
POWER SUPPLIES AND CURRENTS						
V_{3P3}	V3P3 Input voltage range		3	3.3	3.6	V
V_{HV}	VHV Input voltage range		4.5		19.8	V
I_{VHVACT}	Active quiescent current from VHV	HV_EN = 1, EN = 1			150	μA
I_{VHVSD}	Shutdown leakage current from VHV	HV_EN = 0, EN = 0 or 1			60	μA
I_{DDACT}	Active quiescent current from V3P3	EN = 1, HV_EN = 0			500	μA
$I_{DDACTHV}$		EN = 1, HV_EN = 1			500	μA
I_{DDSD}	Shutdown quiescent current from V3P3	EN = 0, OUT = 0 V			30	μA
I_{DIS}	OUT Discharge current	EN = 1, $V_{HV} = 5\text{V}$, HV_EN = 1→0	5		10	mA
I_{IN}	HV_EN, EN, ENHVU, S0, S3 Input pin leakage	$V = 0\text{V}$			1	μA
		$V = V_{3P3}$			1	
SWITCH AND RESISTANCE CHARACTERISTICS						
R_{SHV}	VHV Switch resistance	$V_{HV} = 5\text{V to } 18\text{V}$, $I_{VHV} = 0.9\text{A}$			250	m Ω
R_{S3P3}	V3P3 Switch resistance	$V_{3P3} = 3.3\text{V}$, $I_{V3P3} = 0.9\text{A}$			125	m Ω
$R_{S3P3BYP}$	V3P3 Bypass switch resistance	$V_{3P3} = 3.3\text{V}$, $I_{V3P3} = 500\text{mA}$			500	m Ω
$V_{OLFAULTZ}$	FAULTZ VOL	$I_{FAULTZ} = 250\mu\text{A}$			0.6	V
VOLTAGE THRESHOLDS						
V_{HVUVLO}	VHV Under voltage lockout	VHV Input falling	3.6	4		V
		VHV Input rising		4	4.3	
$V_{3P3UVLO}$	V3P3 Under voltage lockout	V3P3 Input falling	1.8	2.25		V
		V3P3 Input rising		2.25	2.5	
$V_{FAULTZVAL}$	V3P3 Voltage for valid FAULTZ	EN = 1	1.8			V
THERMAL SHUTDOWN						
T_{SD}	Shutdown temperature		110	120	130	$^{\circ}\text{C}$
T_{SDHYST}	Shutdown hysteresis			10		$^{\circ}\text{C}$
CURRENT LIMIT						
I_{LIMHV}	VHV Switch current limit state S0 or S3	$R_{SET_S0,3} = 402\text{ k}\Omega^{(1)}$	80	100	120	mA
		$R_{SET_S0,3} = 80.6\text{ k}\Omega^{(1)}$	446	496	546	
		$R_{SET_S0,3} = 26.7\text{ k}\Omega^{(1)}$	1423	1498	1573	
$I_{LIMVHVMAX}$	Maximum VHV switch current limit	$R_{SET_S0,3} = 0\Omega$	1.8	2.4	3.1	A
I_{LIM3P3}	V3P3 Switch current limit	$R_{SET_V3P3} = 402\text{ k}\Omega^{(1)}$	80	100	120	mA
		$R_{SET_V3P3} = 80.6\text{ k}\Omega^{(1)}$	446	496	546	
		$R_{SET_V3P3} = 26.7\text{ k}\Omega^{(1)}$	1423	1498	1573	
$I_{LIM3P3MAX}$	Maximum V3P3 switch current limit	$R_{SET_V3P3} = 0\Omega$	1.8	2.4	3.1	A
I_{REV3P3}	V3P3 Switch reverse current limit		10	40	85	mA
T_{V3P3RC}	V3P3 Switch reverse current response time	$V_{OUT} = V_{3P3} \rightarrow V_{3P3} + 20\text{mV}$			100	μs
T_{VHVSC}	VHV Switch short circuit response time	$C_{OUT} \leq 20\text{pF}$		8		μs
T_{V3P3SC}	V3P3 Switch short circuit response time	$C_{OUT} \leq 20\text{pF}$		8		μs
TRANSITION DELAYS						
T_{3P3OFF}	VHV to V3P3 Off time	$C_{OUT} = 1.1\mu\text{F}$, EN = 1, HV_EN = 1→0			6	ms
$T_{0-3.3V}$	0V to 3.3V Ramp time	$C_{OUT} \leq 20\text{pF}$			6	ms
$T_{3.3V-VHV}$	3.3V to VHV Ramp time	$C_{OUT} \leq 20\text{pF}$			6	ms
$T_{VHV-3.3V}$	VHV to 3.3V Ramp time	$C_{OUT} \leq 20\text{pF}$			23	ms
T_{LIM}	Overcurrent response time	$C_{OUT} \leq 20\text{pF}$, $I_{OUT} = 6\text{A}$			0.5	ms

(1) Equation 1 is used to calculate the required resistance for a given minimum I_{LIM} . The nearest 1% resistance is chosen and the corresponding I_{LIM} variance is shown.

FUNCTIONAL BLOCK DIAGRAM

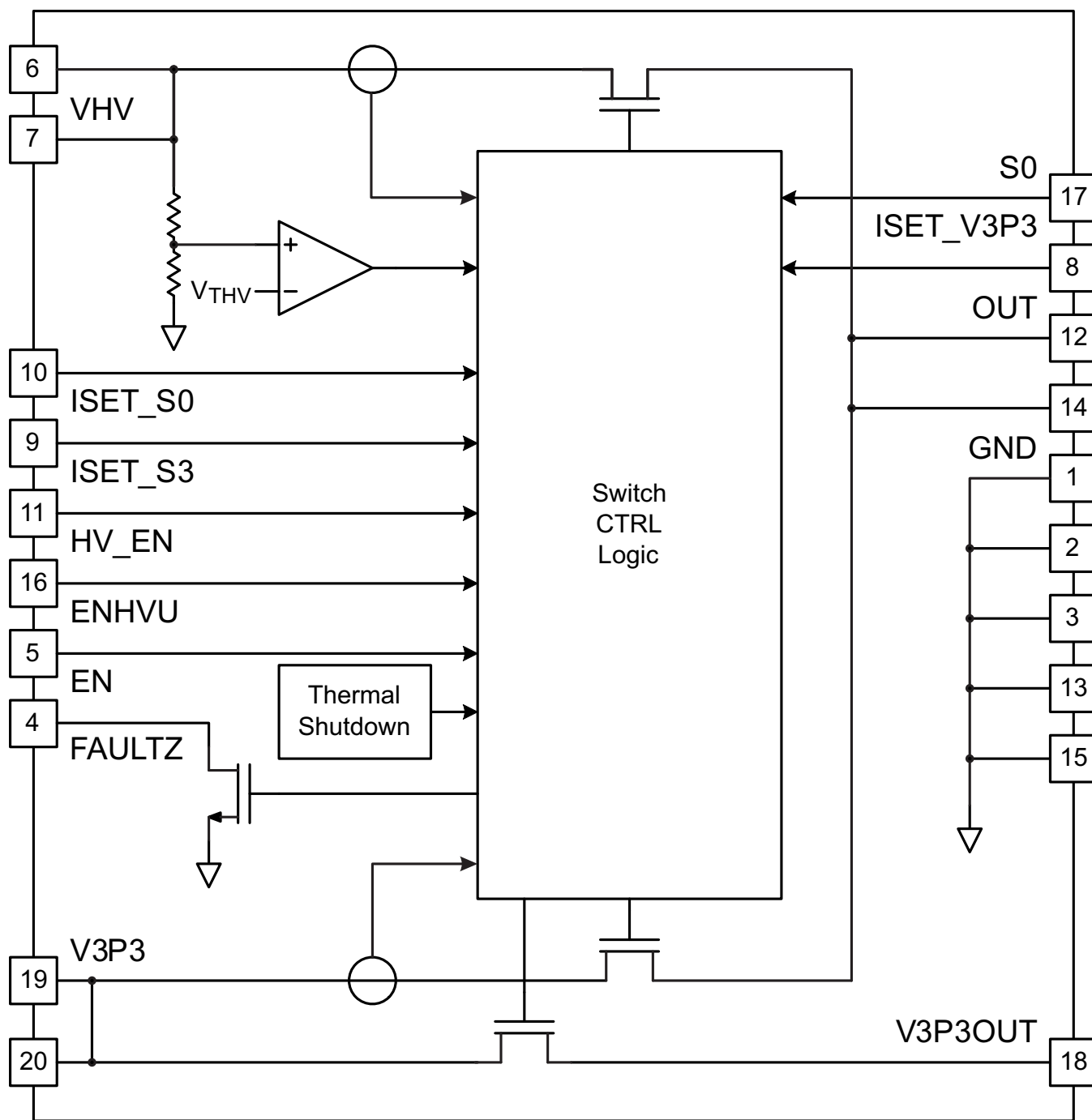

Figure 2. Functional Block Diagram

PIN FUNCTIONS

PIN		DESCRIPTION
NO.	NAME	
1, 2, 3, 13, 15	GND	Device ground. All GND pins must be connected to board ground.
4	FAULTZ	Fault condition output. This pin is an open drain pull-down indicating a fault condition. Place a pull-up resistance (R_{FAULTZ}) between this pin and V3P3. Float pin or tie pin to GND if unused.
5	EN	Device active-high enable.
6, 7	VHV	High voltage power supply input. See the Input Inductive Bounce at Short Circuit section for more information.
8	ISET_V3P3	Sets the current limit for V3P3. Place resistor between this pin and GND. See Equation 3 to calculate resistor value.
9	ISET_S3	Sets the current limit for VHV in S3 mode. Place resistor between this pin and GND. See Equation 1 to calculate resistor value.
10	ISET_S0	Sets the current limit for VHV in S0 mode. Place resistor between this pin and GND. See Equation 2 to calculate resistor value.
11	HV_EN	Active-high voltage output enable.
12, 14	OUT	Power output. Place a minimum of 1 μ F capacitor as close to this pin as possible.
16	ENHVU	Enable VHV UVLO control of device enable. When asserted high, both V3P3 and VHV must be present for device enable. When low, only V3P3 must be present for device enable.
17	S0	When this pin is asserted, the device is put in S0 mode. Otherwise the device operates in S3 mode.
18	V3P3OUT	3.3V bypass output. When ENHVU is low, this path is enabled by EN and the V3P3 UVLO. When ENHVU is high, this path is enabled by EN and both the V3P3 UVLO and the VHV UVLO. Place a minimum of 0.1 μ F capacitor as close to this pin as possible.
19, 20	V3P3	3.3V power supply input. Place a minimum of 0.1 μ F capacitor as close to this pin as possible.
EP	GND	Exposed pad must be connected to device GND.

APPLICATION INFORMATION

TYPICAL APPLICATION

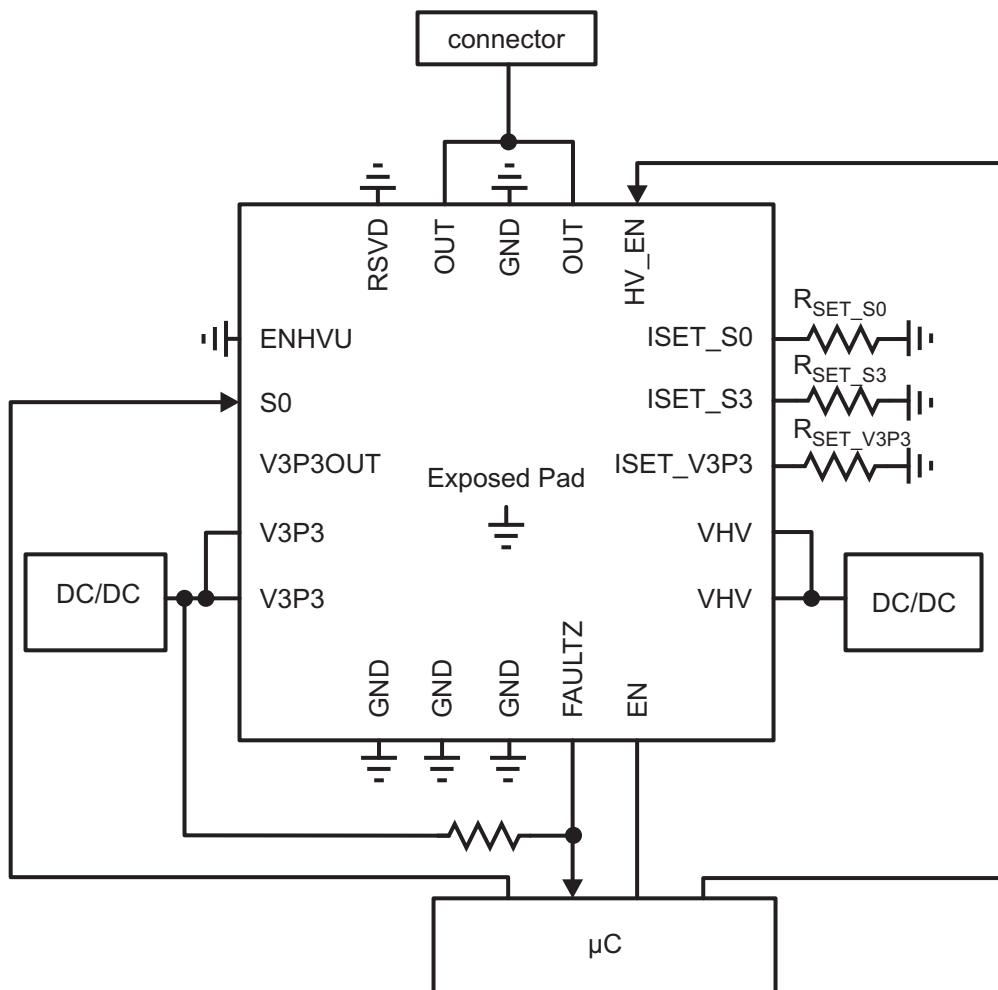

Figure 3. Typical Application

CURRENT LIMIT

Figure 4 shows a simplified view of the TPS22981 current limit function. Both the high voltage supply current limit and the V3P3 supply current limit are adjustable by external resistors

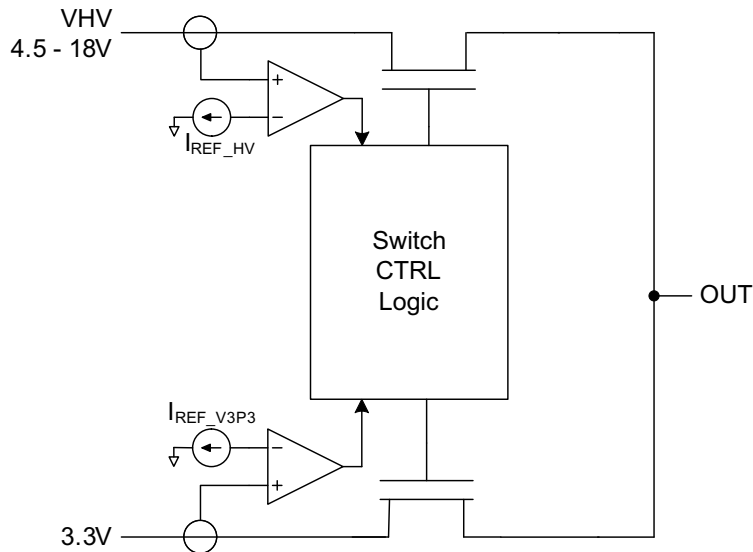

Figure 4. Simplified Current Limit Diagram

The current I_{REF_HV} and I_{REF_V3P3} that set the current limit threshold are set with three external resistors as shown in Figure 5. When the TPS22981 is passing the V3P3 voltage, the current limit is set by R_{SET_V3P3}. The VHV path has two modes that allow setting two different current limits. The S0 pin determines which current limit is used. When S0 is asserted high, R_{SET_S0} sets the current limit. When S0 is low, R_{SET_S3} sets the current limit. This allows the system to have two separate VHV current limits for different modes such as active and sleep.

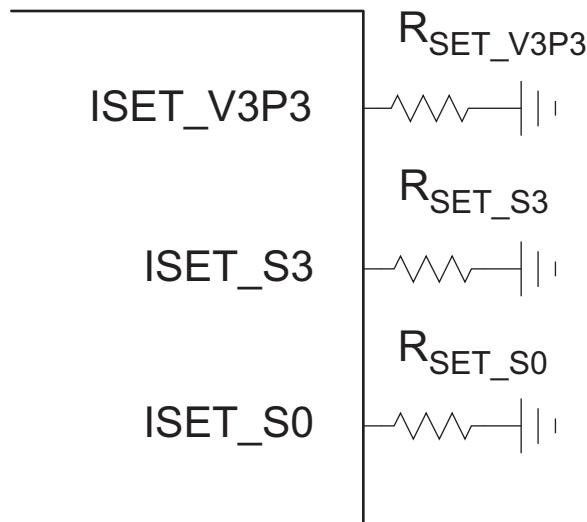

Figure 5. External R_{SET} Resistance to set Current Limits

CURRENT LIMIT THRESHOLD

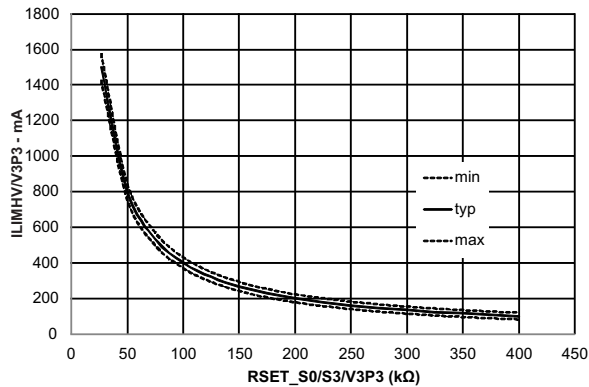

Figure 6. I_{LIM} vs R_{SET} for VHV and V3P3

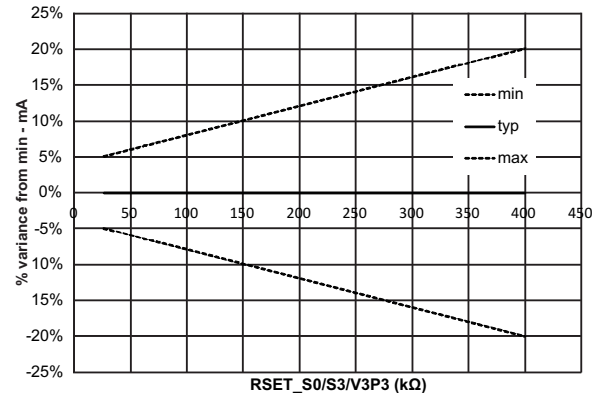

Figure 7. % Variance from min I_{LIM} vs R_{SET}

Figure 6 shows the minimum, typical, and maximum current limit for either supply versus its corresponding R_{SET} value. Equation 1 is used to determine the R_{SET} needed to set a typical I_{LIM} for a given supply and mode. Figure 7 shows the percent variation from the typical I_{LIM} value to the minimum and maximum I_{LIM} values.

$$R_{SET} = \frac{40 \text{ k}\Omega \times \text{Amps}}{I_{LIMTYP}} \quad (1)$$

Where

R_{SET} = external resistor used to set the current limit for V3P3, VHV (S0), or VHV (S3), and

I_{LIMTYP} = typical current limit for V3P3, VHV (S0), or VHV (S3) set by the external R_{SET} resistor.

Each resistor is placed between the corresponding ISET pin and GND, as shown in Figure 5, providing a minimum current limit between 100mA and 1.5A. For a given R_{SET} the minimum current limit and the maximum current limit are determined by Equation 2 and Equation 3.

$$I_{LIMMIN} = \frac{38429}{R_{SET}} - 0.0161 \text{ A} \quad (2)$$

$$I_{LIMMAX} = \frac{41571}{R_{SET}} + 0.0161 \text{ A} \quad (3)$$

MAXIMUM CURRENT LIMIT THRESHOLD

The TPS22981 has a maximum current limit $I_{LIMVHVMAX}$ and $I_{LIM3P3MAX}$. This prevents excessive current in the case of an ISET pin being shorted to ground.

TRANSITION DELAYS

Output transitions of the TPS22981 voltages are shown in Figure 8. When the device transitions from V_{HV} to V_{3P3} at the output, the power switches both turn off until the output falls to near the V_{3P3} voltage. During this time, a discharge current of I_{DIS} pulls OUT down. If a load is also pulling current from OUT, the output will drop to near 0V due to the switch off time of T_{3P3OFF} .

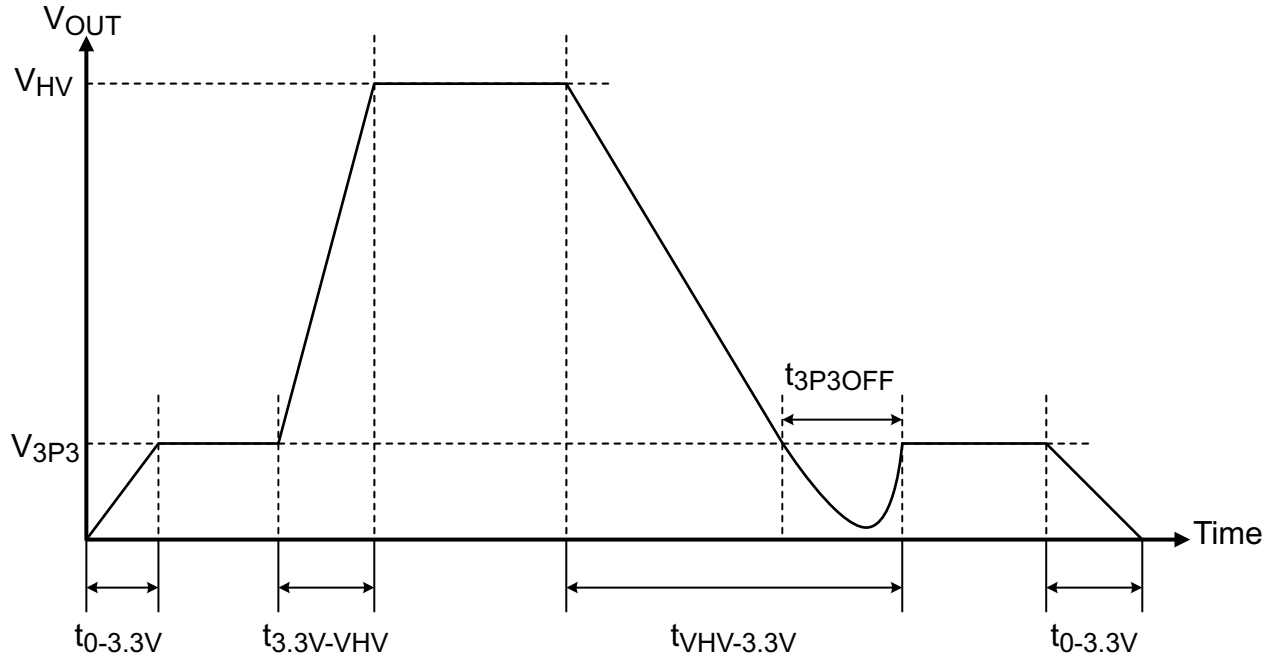

Figure 8. Output Voltage Transitions (Timing transitions are 10% to > 90%)

DIGITAL CONTROL SIGNALS

The voltage at OUT is controlled by two input digital logic signals, EN and HV_EN. HV_EN controls the state of the VHV switch and EN controls the state of V3P3 switch. Table 1 lists the possible output states given the conditions of the digital logic signals and the device is not in UVLO. See Table 2 for a more complete description including both UVLO conditions.

Table 1. Output state of OUT Given the States EN and HV_EN

EN	HV_EN	OUT
0	0	OPEN
0	1	OPEN
1	0	V3P3
1	1	VHV

Figure 9 shows possible combinations of EN and HV_EN controlling OUT of the TPS22981.

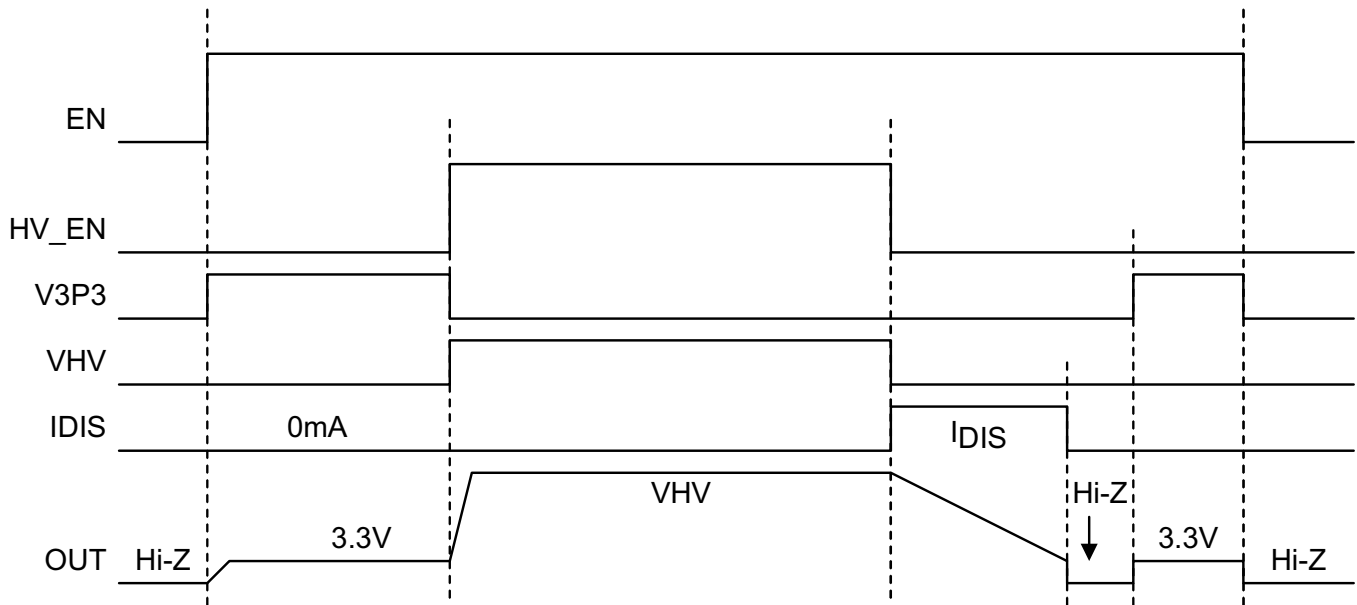

Figure 9. Logic Waveforms Displaying the Transition Between VHV and V3P3

OVER-CURRENT LIMIT AND SHORT CIRCUIT PROTECTION

When the load at OUT attempts to draw more current than the limit set by the external R_{SET} resistors for the V3P3 switch and VHV switch (for both S0 and S3 modes), the device will operate in a constant current mode while lowering the output voltage. Figure 10 shows the delay, t_{LIM} , which occurs from the instance an over-current fault is detected until the output current is lowered to I_{LIMHV} tolerances for VHV or I_{LIM3V3} tolerances for V3P3 shown in Figure 6. Figure 11 shows the response time versus a resistance shorted across the output.

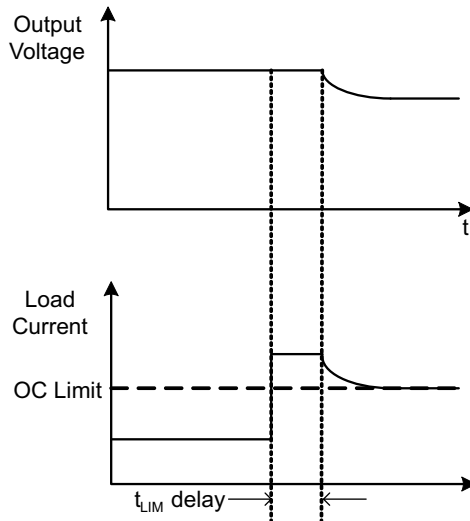

Figure 10. Overcurrent Output Response



Figure 11. Overcurrent Response Time vs Short Resistance

All short circuit conditions are treated as over-current conditions. In the event of a short circuit, the device will limit the output current to the corresponding R_{SET} value and continue to do so until thermal shutdown is encountered or the short circuit condition is removed.

REVERSE CURRENT PROTECTION

Reverse current protection for the V3P3 supply to OUT triggers at I_{REV3P3} causing the V3P3 supply switch to open. When the HV_EN signal is not asserted and reverse current protection is triggered, a discharge current source is turned on to bring the output voltage to near the V3P3 voltage.

REVERSE CURRENT BLOCKING

The VHV switch blocks reverse current flow from OUT to VHV when the switch is off.

THERMAL SHUTDOWN

The device enters thermal shutdown when junction temperature reaches T_{SD} . The device will resume previous state on power up once the junction temperature has dropped by 10C. Connect thermal vias to the exposed GND pad underneath the device package for improved thermal diffusion.

UVLO and ENABLE

When ENHVU is low, the TPS22981 is enabled by the logical AND of the EN input, the V3P3 UVLO, and the Thermal Shutdown. When the V3P3 UVLO threshold has been crossed, the device is not in thermal shutdown, and the EN input is high, the device will enable. When the V3P3 UVLO triggers, regardless of the states of any digital logic controls, the device will open all switches.

ENHVU adds the VHV UVLO to the logical decision enabling the device. When ENHVU is high, the TPS22981 is enabled by the logical AND of the EN input, the V3P3 UVLO, the VHV UVLO, and the Thermal Shutdown. When both UVLO thresholds have been crossed, the device is not in thermal shutdown, and the EN input is high, the device will enable. When either UVLO triggers, regardless of the states of any digital logic controls, the device will open all switches. [Table 2](#) shows the pin and voltage configurations for enabling the device. Note, a 1 for the UVLO columns means the device is in a UVLO condition.

Table 2. Device Enable Control (when in an under-voltage condition, UVLO = 1)

EN	ENHVU	HV_EN	V3P3 UVLO	VHV UVLO	OUT
0	X	X	X	X	OPEN
1	X	X	1	X	OPEN
1	1	X	X	1	OPEN
1	0	0	0	X	V3P3
1	1	0	0	0	V3P3
1	X	1	0	0	VHV
1	0	1	0	1	V3P3

FAULTZ Output

The TPS22981 has an open-drain FAULTZ output. When the device is in a fault condition, the FAULTZ output will pull low. Connect FAULTZ through a pull-up resistance to V3P3. A Fault occurs during any of the following conditions.

- EN = 1 and V3P3 is in UVLO (device enabled and V3P3 is in an under-voltage condition)
- EN = 1 and in Thermal Shutdown condition
- EN = 1, HV_EN = 1, and VHV is in UVLO (device enabled, high voltage enabled, and VHV is in an under-voltage condition)

Table 3 shows these conditions and the resulting FAULTZ output. Note, when V3P3 is below the UVLO threshold, FAULTZ will be 0 when EN=1 or 1 when EN=0. However, when V3P3 falls below $V_{FAULTZVAL}$, the FAULTZ output is unknown.

Table 3. FAULTZ Output Conditions (when in an under-voltage condition, UVLO = 1)

EN	HV_EN	Thermal Shutdown	V3P3 UVLO	VHV UVLO	FAULTZ (Active Low)
0	X	X	X	X	1
1	X	X	1	X	0
1	X	Yes	0	X	0
1	0	No	0	1	1
1	1	No	0	1	0
1	X	No	0	0	1

It is recommended that the pull-up resistance on FAULTZ be 100k Ω and must be greater than or equal to 30k Ω .

INPUT INDUCTIVE BOUNCE AT SHORT CIRCUIT

When a significant inductance is seen at the VHV input, suddenly turning off large current through the device may produce a large enough inductive voltage bounce on the VHV pin to exceed the maximum safe operating condition and damage the TPS22981. To prevent this, reduce any inductance at the VHV input.

PACKAGING INFORMATION

Orderable Device	Status (1)	Package Type	Package Drawing	Pins	Package Qty	Eco Plan (2)	Lead finish/ Ball material (6)	MSL Peak Temp (3)	Op Temp (°C)	Device Marking (4/5)	Samples
TPS22981RGPR	ACTIVE	QFN	RGP	20	3000	RoHS & Green	NIPDAU	Level-2-260C-1 YEAR	-40 to 85	PS22981	Samples
TPS22981RGPT	ACTIVE	QFN	RGP	20	250	RoHS & Green	NIPDAU	Level-2-260C-1 YEAR	-40 to 85	PS22981	Samples

(1) The marketing status values are defined as follows:

ACTIVE: Product device recommended for new designs.

LIFEBUY: TI has announced that the device will be discontinued, and a lifetime-buy period is in effect.

NRND: Not recommended for new designs. Device is in production to support existing customers, but TI does not recommend using this part in a new design.

PREVIEW: Device has been announced but is not in production. Samples may or may not be available.

OBSELETE: TI has discontinued the production of the device.

(2) **RoHS:** TI defines "RoHS" to mean semiconductor products that are compliant with the current EU RoHS requirements for all 10 RoHS substances, including the requirement that RoHS substance do not exceed 0.1% by weight in homogeneous materials. Where designed to be soldered at high temperatures, "RoHS" products are suitable for use in specified lead-free processes. TI may reference these types of products as "Pb-Free".

RoHS Exempt: TI defines "RoHS Exempt" to mean products that contain lead but are compliant with EU RoHS pursuant to a specific EU RoHS exemption.

Green: TI defines "Green" to mean the content of Chlorine (Cl) and Bromine (Br) based flame retardants meet JS709B low halogen requirements of <=1000ppm threshold. Antimony trioxide based flame retardants must also meet the <=1000ppm threshold requirement.

(3) MSL, Peak Temp. - The Moisture Sensitivity Level rating according to the JEDEC industry standard classifications, and peak solder temperature.

(4) There may be additional marking, which relates to the logo, the lot trace code information, or the environmental category on the device.

(5) Multiple Device Markings will be inside parentheses. Only one Device Marking contained in parentheses and separated by a "~" will appear on a device. If a line is indented then it is a continuation of the previous line and the two combined represent the entire Device Marking for that device.

(6) Lead finish/Ball material - Orderable Devices may have multiple material finish options. Finish options are separated by a vertical ruled line. Lead finish/Ball material values may wrap to two lines if the finish value exceeds the maximum column width.

Important Information and Disclaimer:The information provided on this page represents TI's knowledge and belief as of the date that it is provided. TI bases its knowledge and belief on information provided by third parties, and makes no representation or warranty as to the accuracy of such information. Efforts are underway to better integrate information from third parties. TI has taken and continues to take reasonable steps to provide representative and accurate information but may not have conducted destructive testing or chemical analysis on incoming materials and chemicals. TI and TI suppliers consider certain information to be proprietary, and thus CAS numbers and other limited information may not be available for release.

In no event shall TI's liability arising out of such information exceed the total purchase price of the TI part(s) at issue in this document sold by TI to Customer on an annual basis.

GENERIC PACKAGE VIEW

RGP 20

VQFN - 1 mm max height

4 x 4, 0.5 mm pitch

VERY THIN QUAD FLATPACK

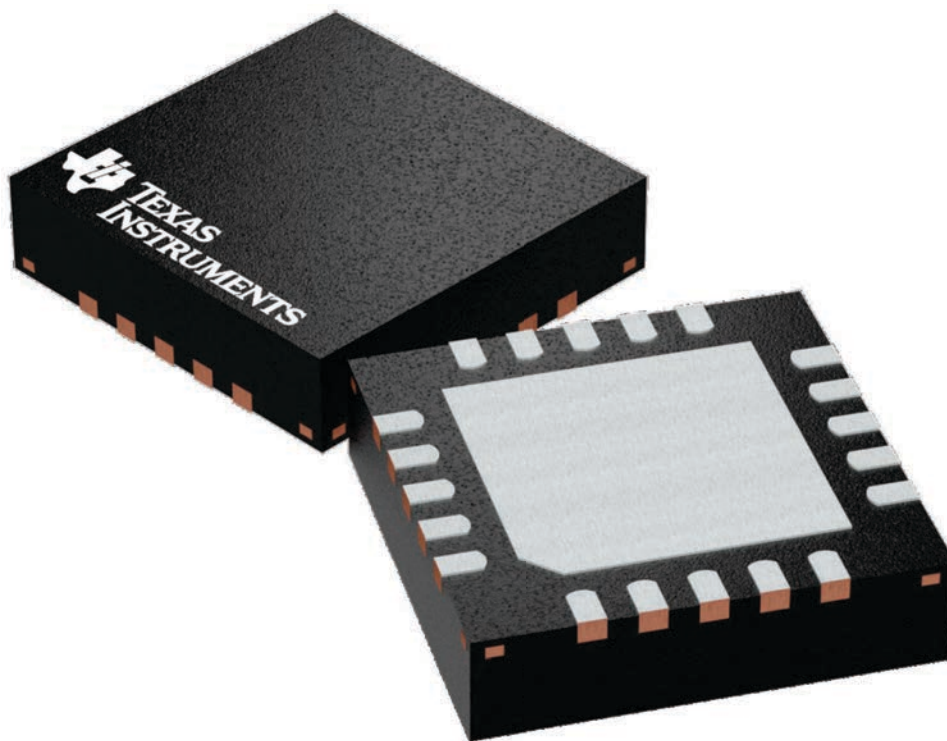

Images above are just a representation of the package family, actual package may vary.
Refer to the product data sheet for package details.

4224735/A

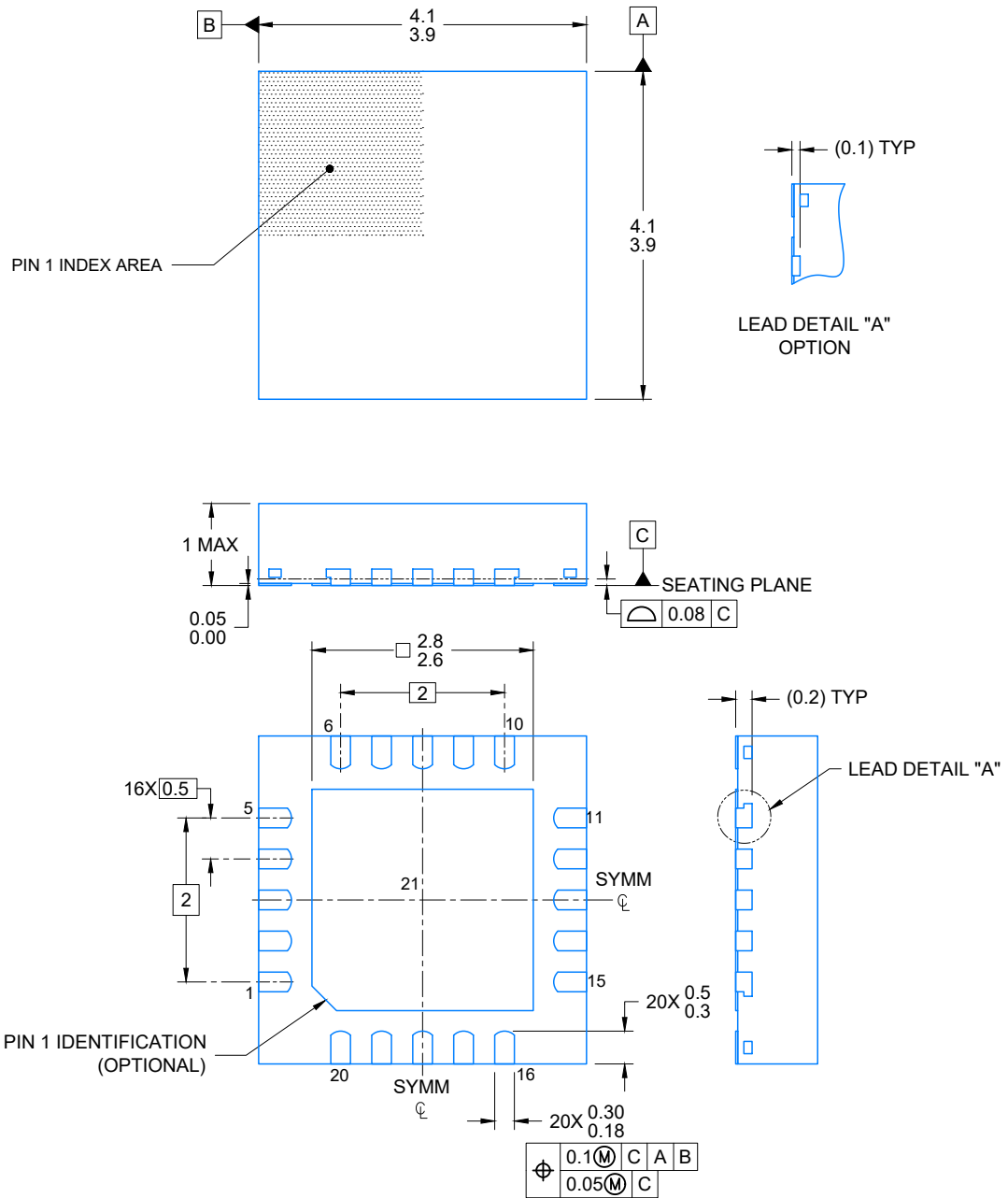

4219028/A 12/2018

NOTES:

1. All linear dimensions are in millimeters. Any dimensions in parenthesis are for reference only. Dimensioning and tolerancing per ASME Y14.5M.
2. This drawing is subject to change without notice.
3. The package thermal pad must be soldered to the printed circuit board for optimal thermal and mechanical performance.

EXAMPLE BOARD LAYOUT

VQFN - 1 mm max height

RGP0020D

PLASTIC QUAD FLATPACK- NO LEAD

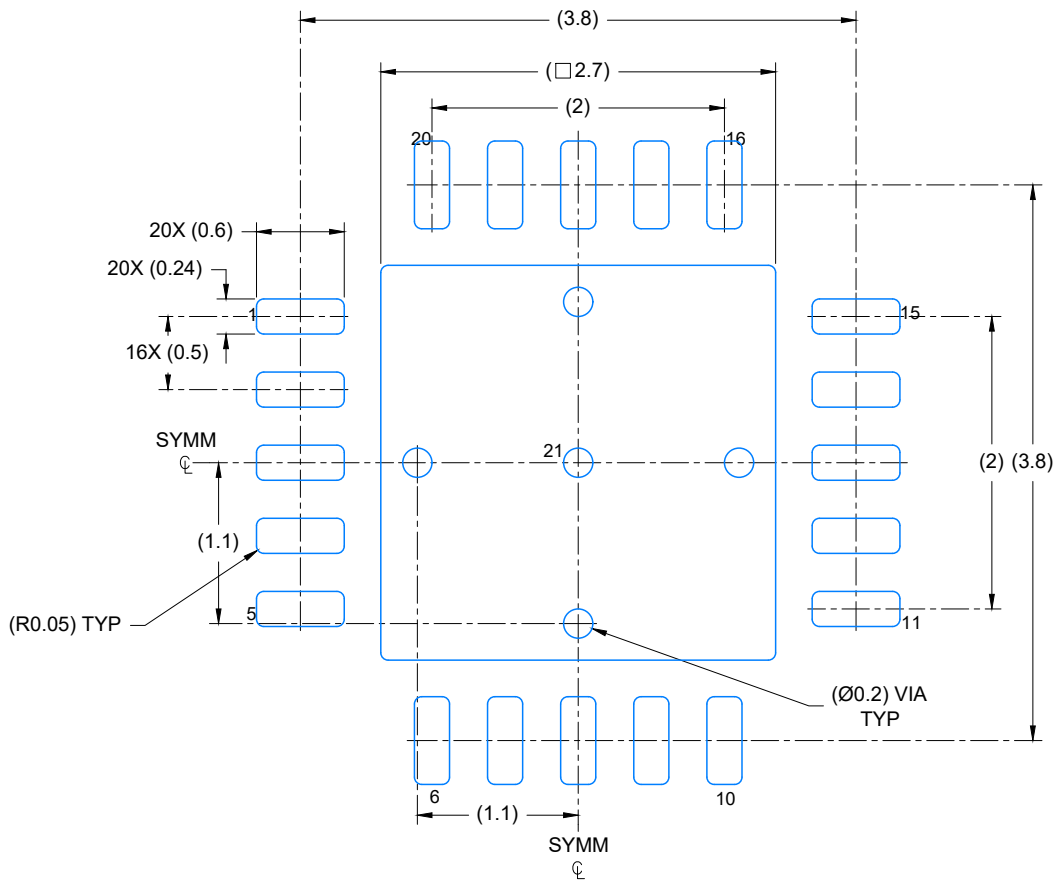

LAND PATTERN EXAMPLE
EXPOSED METAL SHOWN
SCALE: 20X

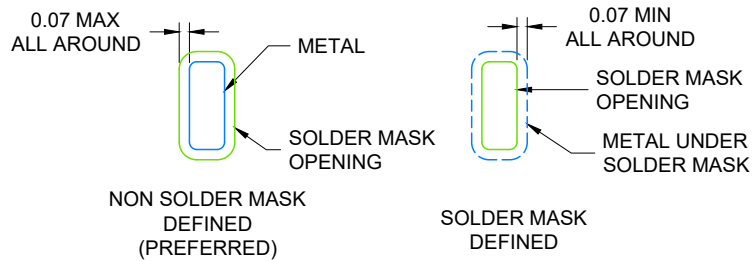

SOLDER MASK DETAILS

4219028/A 12/2018

NOTES: (continued)

4. This package is designed to be soldered to a thermal pad on the board. For more information, see Texas Instruments literature number SLUA271 (www.ti.com/lit/sluea271).
5. Vias are optional depending on application, refer to device data sheet. If any vias are implemented, refer to their locations shown on this view. It is recommended that vias under paste be filled, plugged or tented.

EXAMPLE STENCIL DESIGN

RGP0020D

VQFN - 1 mm max height

PLASTIC QUAD FLATPACK- NO LEAD

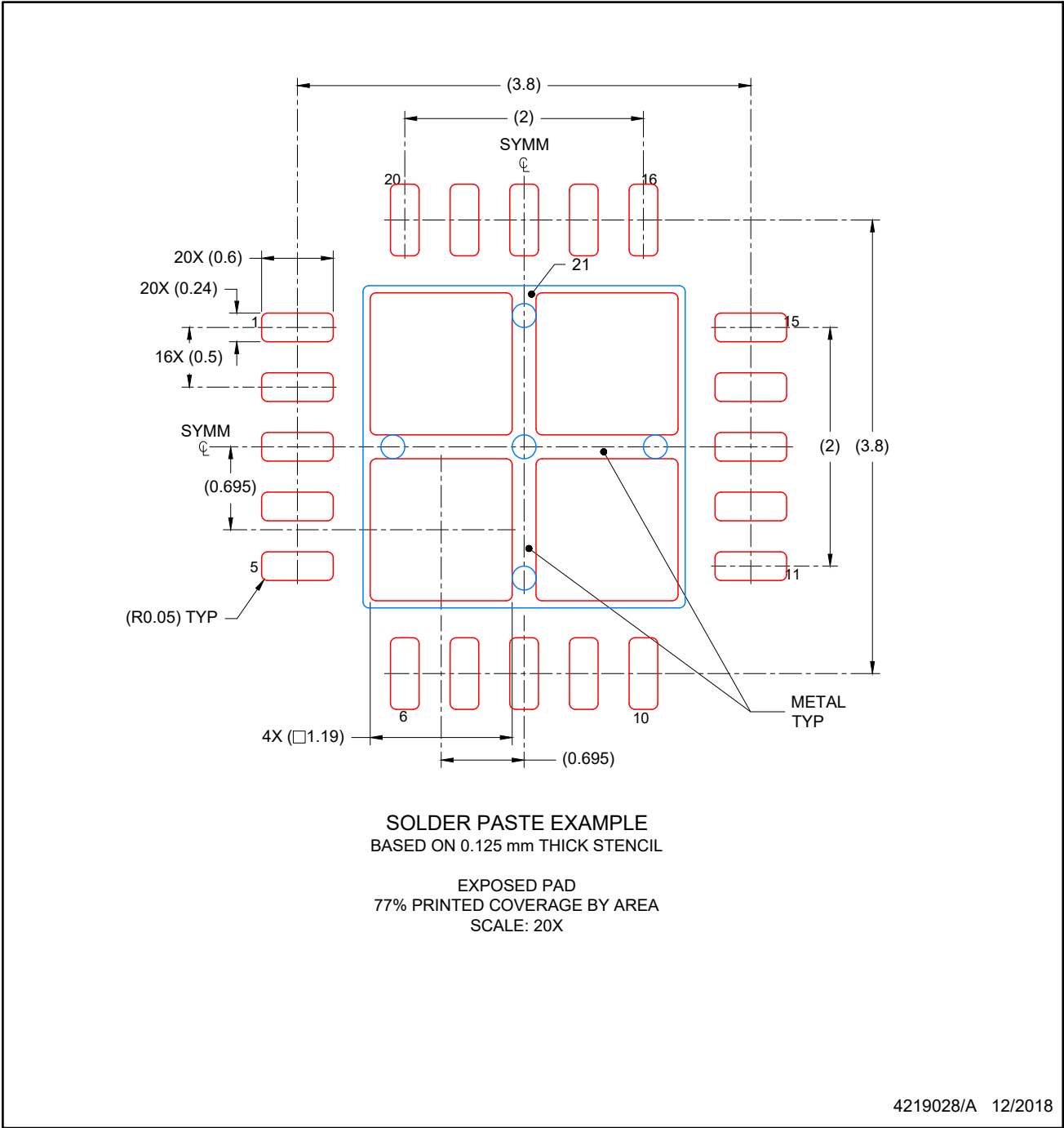

NOTES: (continued)

- 6. Laser cutting apertures with trapezoidal walls and rounded corners may offer better paste release. IPC-7525 may have alternate design recommendations.

重要声明和免责声明

TI 提供技术和可靠性数据（包括数据表）、设计资源（包括参考设计）、应用或其他设计建议、网络工具、安全信息和其他资源，不保证没有瑕疵且不做任何明示或暗示的担保，包括但不限于对适销性、某特定用途方面的适用性或不侵犯任何第三方知识产权的暗示担保。

这些资源可供使用 TI 产品进行设计的熟练开发人员使用。您将自行承担以下全部责任：(1) 针对您的应用选择合适的 TI 产品，(2) 设计、验证并测试您的应用，(3) 确保您的应用满足相应标准以及任何其他安全、安保或其他要求。这些资源如有变更，恕不另行通知。TI 授权您仅可将这些资源用于研发本资源所述的 TI 产品的应用。严禁对这些资源进行其他复制或展示。您无权使用任何其他 TI 知识产权或任何第三方知识产权。您应全额赔偿因在这些资源的使用中对 TI 及其代表造成的任何索赔、损害、成本、损失和债务，TI 对此概不负责。

TI 提供的产品受 TI 的销售条款 (<https://www.ti.com.cn/zh-cn/legal/termsofsale.html>) 或 [ti.com.cn](https://www.ti.com.cn) 上其他适用条款/TI 产品随附的其他适用条款的约束。TI 提供这些资源并不会扩展或以其他方式更改 TI 针对 TI 产品发布的适用的担保或担保免责声明。

邮寄地址：上海市浦东新区世纪大道 1568 号中建大厦 32 楼，邮政编码：200122

Copyright © 2021 德州仪器半导体技术（上海）有限公司