

## TPS25221 2.5V 至 5.5V、2A 持续电流限制开关

### 1 特性

- 2.5V 至 5.5V  $V_{\text{OPERATING}}$
- 与 TPS2553 引脚对引脚兼容
- 2A  $I_{\text{CONT\_MAX}}$
- 0.275A 至 1.7A 可调节  $I_{\text{LIMIT}}$  (2.7A 时精度为  $\pm 6.5\%$ )
- 70m $\Omega$  (典型值)  $R_{\text{ON}}$
- 1.5 $\mu\text{s}$  短路响应
- 8ms 故障报告抗尖峰脉冲
- 反向电流阻断 (禁用时)
- 内置软启动
- UL 60950 和 UL 62368 认证
- 15kV ESD 保护, 符合 IEC 61000-4-2 标准 (带外部电容)

### 2 应用

- USB 端口/集线器、笔记本、台式机
- 高清电视
- 机顶盒
- 可选插座保护

### 3 说明

TPS25221 旨在用于可能会遇到大电容负载和短路事件的应用。可编程电流限制阈值可通过一个外部电阻器设定在 275mA 至 2.7A (典型值) 之间。在更高电流限制设置上可实现严格至  $\pm 6\%$  的  $I_{\text{LIMIT}}$  精度。通过控制电源开关的上升时间和下降时间, 可最大限度地降低开通和关断期间的电流浪涌。

当负载尝试吸收超过编程的  $I_{\text{LIMIT}}$  的电流时, 内部 FET 会进入恒定电流模式, 以确保  $I_{\text{LOAD}}$  等于或低于  $I_{\text{LIMIT}}$ 。在固有的抗尖峰脉冲时间之后,  $\overline{\text{FAULT}}$  输出将会在过流状态期间维持低电平。

器件信息<sup>(1)</sup>

器件型号	封装	封装尺寸 (标称值)
TPS25221	SOT-23 (6)	2.90mm x 1.60mm
	WSON (6)	2.00mm x 2.00mm

(1) 如需了解所有可用封装, 请参阅数据表末尾的可订购产品附录。

简化原理图

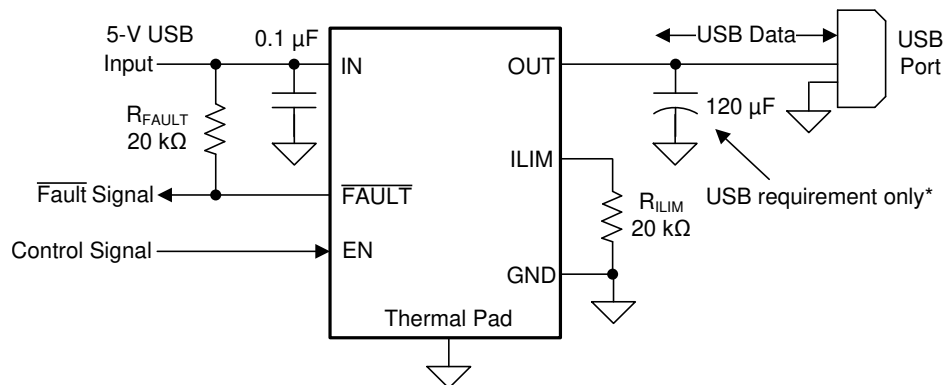

\*USB requirement that downstream facing ports are bypassed with at least 120  $\mu\text{F}$  per hub.

目录

1	特性 .....	1	10	Application and Implementation .....	14
2	应用 .....	1	10.1	Application Information .....	14
3	说明 .....	1	10.2	Typical Applications .....	15
4	修订历史记录 .....	2	11	Power Supply Recommendations .....	21
5	Device Comparison Table .....	3	11.1	Self-Powered and Bus-Powered Hubs .....	21
6	Pin Configuration and Functions .....	3	11.2	Low-Power Bus-Powered and High-Power Bus-Powered Functions .....	21
7	Specifications .....	4	11.3	Power Dissipation and Junction Temperature .....	21
7.1	Absolute Maximum Ratings .....	4	12	Layout .....	23
7.2	ESD Ratings .....	4	12.1	Layout Guidelines .....	23
7.3	Recommended Operating Conditions .....	4	12.2	Layout Example .....	23
7.4	Thermal Information .....	4	13	器件和文档支持 .....	24
7.5	Electrical Characteristics .....	5	13.1	器件支持 .....	24
7.6	Typical Characteristics .....	7	13.2	文档支持 .....	24
8	Parameter Measurement Information .....	10	13.3	接收文档更新通知 .....	24
9	Detailed Description .....	11	13.4	社区资源 .....	24
9.1	Overview .....	11	13.5	商标 .....	24
9.2	Functional Block Diagram .....	11	13.6	静电放电警告 .....	24
9.3	Feature Description .....	12	13.7	Glossary .....	24
9.4	Device Functional Modes .....	13	14	机械、封装和可订购信息 .....	24
9.5	Programming .....	13			

4 修订历史记录

<b>Changes from Revision C (May 2019) to Revision D</b>		<b>Page</b>
•	Removed content from the <i>Programming the Current-Limit Threshold</i> section .....	13
<b>Changes from Revision B (November 2018) to Revision C</b>		<b>Page</b>
•	Changed the Storage temperature From: TBD to: MIN = -65°C MAX = 150°C in the <i>Absolute Maximum Ratings</i> .....	4
<b>Changes from Revision A (May 2018) to Revision B</b>		<b>Page</b>
•	已删除 <i>特性</i> 列表项中的“正在申请”字样 .....	1
<b>Changes from Original (January 2018) to Revision A</b>		<b>Page</b>
•	已投入量产 .....	1

## 5 Device Comparison Table

MAX OPERATING CURRENT	OUTPUT DISCHARGE	ENABLE	CURRENT LIMIT	LATCH OFF	Package	BASE PART NUMBER
2	N	High	Adjustable	N	SOT-23 (6)	TPS25221DBV
2	N	High	Adjustable	N	WSON (6)	TPS25221DRV

## 6 Pin Configuration and Functions



### Pin Functions

NAME	PIN		I/O	DESCRIPTION
	SOT-23	WSON		
IN	1	6	I	Input voltage and power switch drain; connect a 0.1 $\mu$ F or greater ceramic capacitor from IN to GND close to IC
GND	2	5	--	Ground connection
EN	3	4	I	Enable input, logic high/low turns on power switch
$\overline{\text{FAULT}}$	4	3	O	Active-low open-drain output, asserted during over-current, or over-temperature conditions
ILIM	5	2	O	External resistor used to set current limit threshold
OUT	6	1	O	Power switch output, connect to load
Thermal Pad	--	PAD	--	Internally connected to GND; used to heat-sink the part to the circuit board traces. Connect thermal pad to GND pin externally.

## 7 Specifications

### 7.1 Absolute Maximum Ratings

over operating free-air temperature range (unless otherwise noted)<sup>(1)</sup>

	MIN	MAX	UNIT
Voltage range on IN, OUT, EN, $\overline{\text{FAULT}}$ , ILIM	-0.3	6	V
Voltage range from IN to OUT	-6	6	
Continuous $\overline{\text{FAULT}}$ sink current	0	25	mA
ILIM source current	0	1	mA
Maximum junction temperature, $T_j$	Internally Limited		
Storage temperature, $T_{\text{stg}}$	-65	150	°C

- (1) Stresses beyond those listed under *Absolute Maximum Ratings* may cause permanent damage to the device. These are stress ratings only, which do not imply functional operation of the device at these or any other conditions beyond those indicated under *Recommended Operating Conditions*. Exposure to absolute-maximum-rated conditions for extended periods may affect device reliability.

### 7.2 ESD Ratings

		VALUE	UNIT
$V_{\text{(ESD)}}$	Electrostatic discharge		
	Human-body model (HBM), per ANSI/ESDA/JEDEC JS-001 <sup>(1)</sup>	±2000	V
	Charged-device model (CDM), per JEDEC specification JESD22-C101 or ANSI/ESDA/JEDEC JS-002 <sup>(2)</sup>	±500	V
	IEC 61000-4-2 contact discharge <sup>(3)</sup>	±8000	V
	IEC 61000-4-2 air-gap discharge <sup>(3)</sup>	±15000	V

- (1) JEDEC document JEP155 states that 500-V HBM allows safe manufacturing with a standard ESD control process.  
 (2) JEDEC document JEP157 states that 250-V CDM allows safe manufacturing with a standard ESD control process.  
 (3) Surges per EN61000-4-2. 1999 applied to output terminals of EVM. These are passing tests levels, not failure threshold.

### 7.3 Recommended Operating Conditions

Voltages are respect to GND (unless otherwise noted)

			MIN	NOM	MAX	UNIT
$V_{\text{IN}}$	Supply voltage	IN	2.5		5.5	V
$V_{\text{EN}}$	Input voltage	EN	0		5.5	V
$V_{\text{IH}}$	High-level input voltage	EN	1.7			V
$V_{\text{IL}}$	Low-level input voltage	EN			0.66	V
$I_{\text{CON}}$	Output continuous current	OUT	0		2	A
$R_{\text{ILIM}}$	Current-limit threshold resistor range (nominal 1%) from ILIM to GND		20		210	kΩ
$I_{\text{FAULT}}$	Sink current into $\overline{\text{FAULT}}$	$\overline{\text{FAULT}}$	0		10	mA
$T_j$	Operating junction temperature		-40		125	°C

### 7.4 Thermal Information

THERMAL METRIC <sup>(1)</sup>	TPS25221		UNIT	
	DBV (SOT-23)	DRV (WSON)		
	6-PIN	6-PIN		
$R_{\theta\text{JA}}$	Junction-to-ambient thermal resistance	193.2	83	°C/W
$R_{\theta\text{JC(top)}}$	Junction-to-case (top) thermal resistance	127.1	100.5	°C/W
$R_{\theta\text{JB}}$	Junction-to-board thermal resistance	65.6	46.5	°C/W
$\psi_{\text{JT}}$	Junction-to-top characterization parameter	49.0	8.7	°C/W
$\psi_{\text{JB}}$	Junction-to-board characterization parameter	65.3	46.4	°C/W
$R_{\theta\text{JC(bot)}}$	Junction-to-case (bottom) thermal resistance	--	24.4	°C/W

- (1) Proper thermal design is required to ensure  $T_j < 125^\circ\text{C}$  for best long term reliability. This is particularly important at higher currents, see the [Semiconductor and IC Package Thermal Metrics](#) application report.

## 7.5 Electrical Characteristics

over recommended operating conditions,  $V_{EN} = V_{IN}$ ,  $R_{FAULT} = 10\text{ k}\Omega$  (unless otherwise noted)

PARAMETER		TEST CONDITIONS		MIN	TYP	MAX	UNIT		
<b>POWER SWITCH</b>									
$r_{DS(on)}$	Static drain-source on-state resistance	DBV package, $T_J = 25^\circ\text{C}$		70	80		m $\Omega$		
		DBV package, $-40^\circ\text{C} \leq T_J \leq 125^\circ\text{C}$				110			
		DRV package, $T_J = 25^\circ\text{C}$		70	92				
		DRV package, $-40^\circ\text{C} \leq T_J \leq 125^\circ\text{C}$				122			
$r$	Rise time, output	$V_{IN} = 5.5\text{ V}$	$C_L = 1\text{ }\mu\text{F}$ , $R_L = 100\text{ }\Omega$ , (see 图 1)	0.55	0.95		ms		
		$V_{IN} = 2.5\text{ V}$		0.35	0.62				
$t_f$	Fall time, output	$V_{IN} = 5.5\text{ V}$		0.24	0.3				
		$V_{IN} = 2.5\text{ V}$		0.22	0.28				
<b>ENABLE INPUT EN OR <math>\overline{\text{EN}}</math></b>									
	Enable pin turn on/off threshold				0.8			1.6	V
$I_{EN}$	Input current	$V_{EN} = 0\text{ V}$ or $5.5\text{ V}$		-0.5	0	0.5	$\mu\text{A}$		
$t_{on}$	Turnon time	$C_L = 1\text{ }\mu\text{F}$ , $R_L = 100\text{ }\Omega$ , (see 图 2)				3	ms		
$t_{off}$	Turnoff time	$C_L = 1\text{ }\mu\text{F}$ , $R_L = 100\text{ }\Omega$ , (see 图 2)				0.7	ms		
<b>CURRENT LIMIT</b>									
$I_{OS}$	Current-limit threshold (Maximum DC output current $I_{OUT}$ delivered to load) and Short-circuit current, $I_{OUT}$ connected to GND	$R_{ILIM} = 20\text{ k}\Omega$	$T_J = 25^\circ\text{C}$	2585	2720	2850	mA		
			$-40^\circ\text{C} \leq T_J \leq 125^\circ\text{C}$	2560		2880			
		$R_{ILIM} = 30\text{ k}\Omega$	$T_J = 25^\circ\text{C}$	1710	1820	1930			
			$-40^\circ\text{C} \leq T_J \leq 125^\circ\text{C}$	1700		1945			
		$R_{ILIM} = 80\text{ k}\Omega$	$T_J = 25^\circ\text{C}$	630	690	755			
			$-40^\circ\text{C} \leq T_J \leq 125^\circ\text{C}$	610		790			
$R_{ILIM} = 210\text{ k}\Omega$	$T_J = 25^\circ\text{C}$	220	275	330					
	$-40^\circ\text{C} \leq T_J \leq 125^\circ\text{C}$	210		370					
$t_{IOS}$	Response time to short circuit	$V_{IN} = 5\text{ V}$ (see 图 4)			1.5		$\mu\text{s}$		
<b>SUPPLY CURRENT</b>									
$I_{SD}$	Supply current, switch disable	$V_{IN} = 5.5\text{ V}$ , No load on OUT, $V_{EN} = 0\text{ V}$ , $R_{ILIM} = 20\text{ k}\Omega$			0.02	0.5	$\mu\text{A}$		
$I_{SE}$	Supply current, switch enable	$V_{IN} = 5.5\text{ V}$ , No load on OUT, $R_{ILIM} = 20\text{ k}\Omega$			75	90	$\mu\text{A}$		
<b>UNDERVOLTAGE LOCKOUT</b>									
UVLO	Low-level input voltage, IN	$V_{IN}$ rising			2.37	2.47	V		
	Hysteresis, IN	$T_J = 25^\circ\text{C}$			45		mV		
<b>FAULT FLAG</b>									
$V_{OL}$	Output low voltage, $\overline{\text{FAULT}}$	$I_{FAULT} = 1\text{ mA}$				180	mV		
	Off-state leakage	$V_{FAULT} = 5.5\text{ V}$				0.5	$\mu\text{A}$		
	$\overline{\text{FAULT}}$ deglitch	$\overline{\text{FAULT}}$ assertion or de-assertion due to overcurrent condition		6	8	12	ms		
<b>THERMAL SHUTDOWN</b>									
	Thermal shutdown threshold				165		$^\circ\text{C}$		
	Thermal shutdown threshold in current-limit				145		$^\circ\text{C}$		
	Hysteresis				20		$^\circ\text{C}$		

**图 1. Power-On and Off Timing**

**图 2. Enable Timing, Active High Enable**

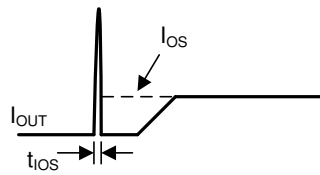
**图 3. Enable Timing, Active Low Enable**

**图 4. Output Short Circuit Parameters**

## 7.6 Typical Characteristics

See 图 21 for reference schematic



$V_{IN} = 5\text{ V}$ ,  $R_{ILIM} = 20\text{ k}\Omega$ ,  $R_{OUT} = 5\ \Omega$

图 5. Turnon Delay and Rise Time



$V_{IN} = 5\text{ V}$ ,  $R_{ILIM} = 20\text{ k}\Omega$ ,  $R_{OUT} = 5\ \Omega$

图 6. Turnoff Delay and Fall Time



$V_{IN} = 5\text{ V}$ ,  $R_{ILIM} = 20\text{ k}\Omega$ ,  $R_{OUT} = 0\ \Omega$

图 7. Device Enabled into Short-Circuit



$V_{IN} = 5\text{ V}$ ,  $R_{ILIM} = 20\text{ k}\Omega$

图 8. Full-Load to Short-Circuit Transient Response



$V_{IN} = 5\text{ V}$ ,  $R_{ILIM} = 20\text{ k}\Omega$

图 9. Short-Circuit to Full-Load Recovery Response



$V_{IN} = 5\text{ V}$ ,  $R_{ILIM} = 20\text{ k}\Omega$

图 10. No-Load to Short-Circuit Transient Response

Typical Characteristics (接下页)

See 图 21 for reference schematic

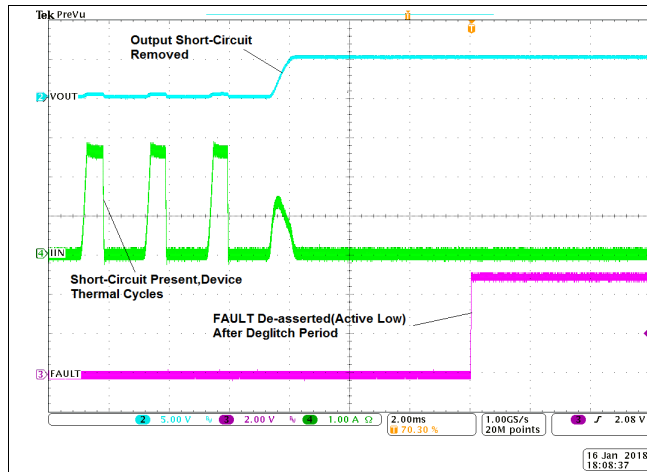

$V_{IN} = 5\text{ V}$ ,  $R_{ILIM} = 20\text{ k}\Omega$

图 11. Short-Circuit to No-Load Recovery Response

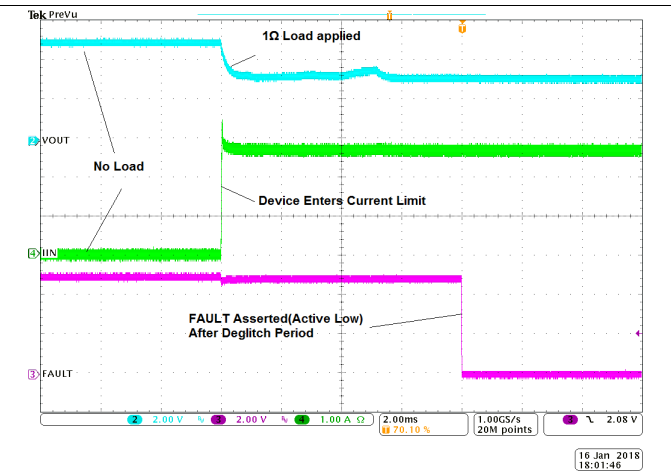

$V_{IN} = 5\text{ V}$ ,  $R_{ILIM} = 20\text{ k}\Omega$

图 12. No Load to 1-Ω Transient Response

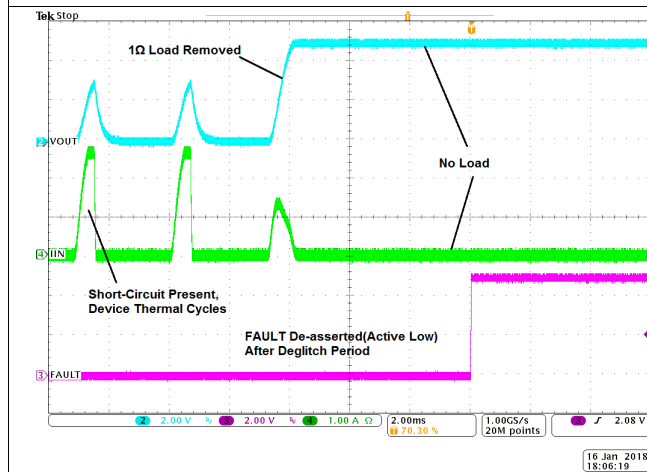

$V_{IN} = 5\text{ V}$ ,  $R_{ILIM} = 20\text{ k}\Omega$

图 13. 1-Ω to No Load Transient Response



图 14. UVLO – Undervoltage Lockout – V



图 15.  $I_{IN}$  – Supply Current, Output Disabled –  $\mu\text{A}$

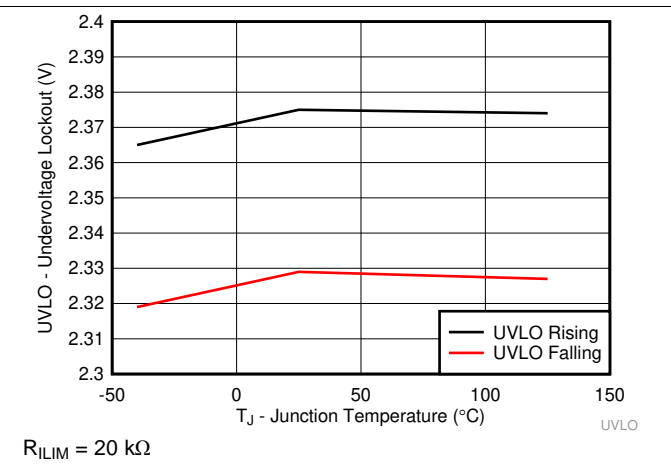

图 16.  $I_{IN}$  – Supply Current, Output Enabled –  $\mu\text{A}$

Typical Characteristics (接下页)

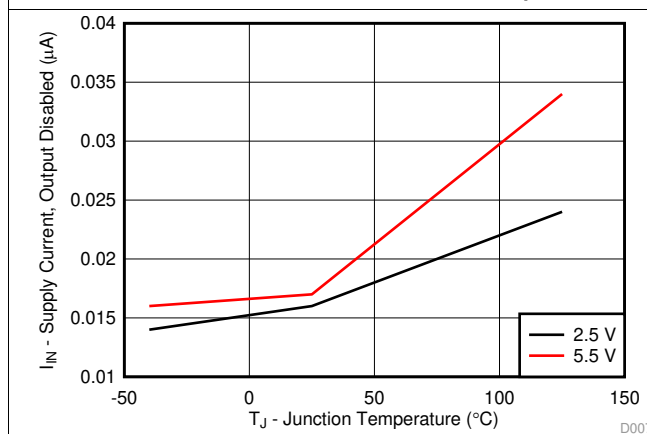
See 图 21 for reference schematic

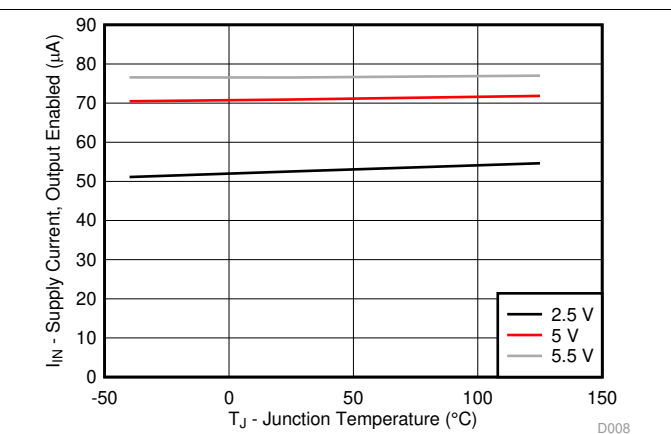
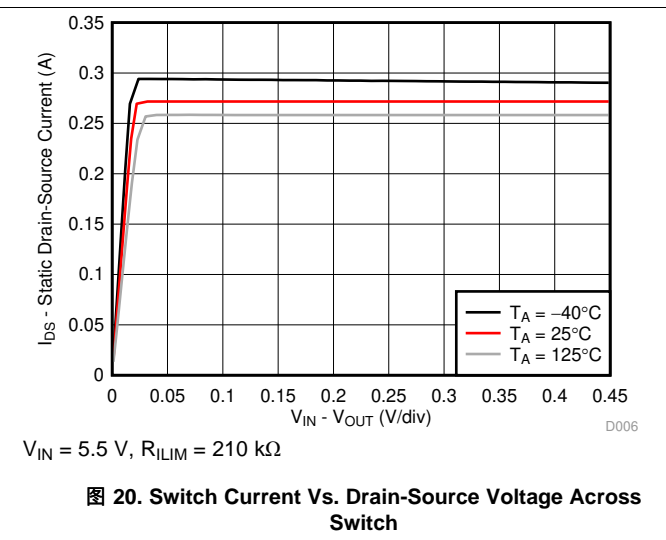
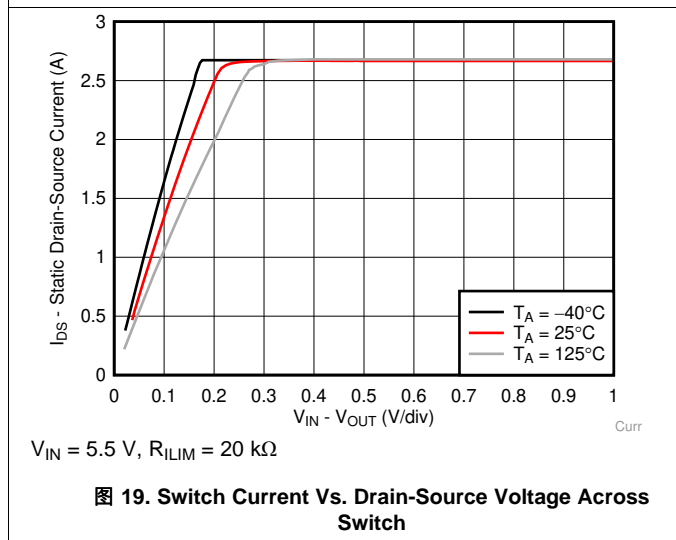
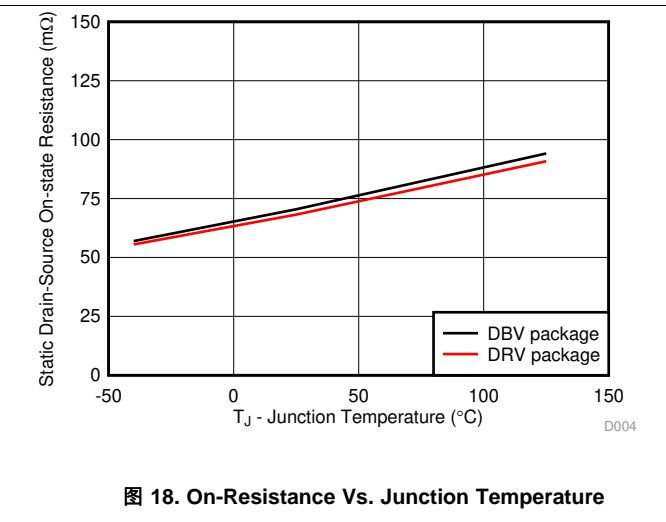
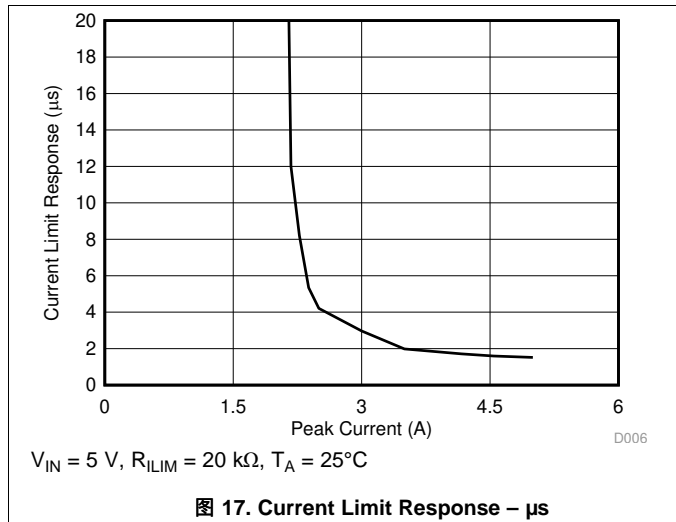

## 8 Parameter Measurement Information



图 21. Typical Characteristics Reference Schematic



图 22. Output Rise / Fall Test Load

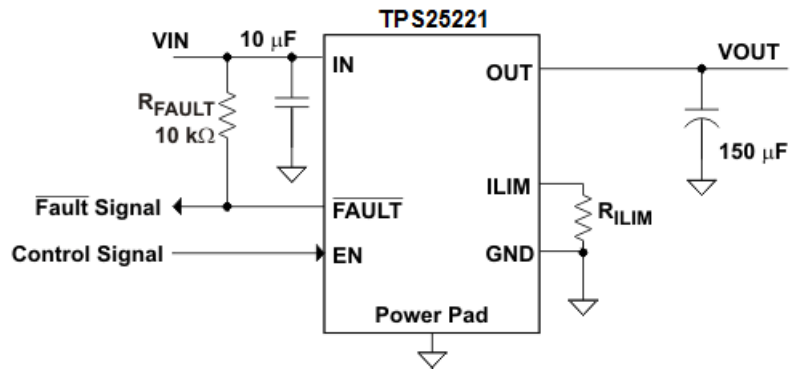

图 23. Output Voltage vs Current-Limit Threshold

## 9 Detailed Description

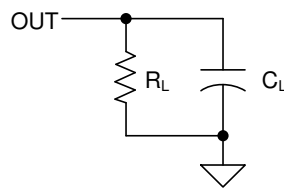
### 9.1 Overview

The TPS25221 is current-limited, power-distribution switch using N-channel MOSFETs for applications where short circuits or heavy capacitive loads are encountered. The TPS25221 allows the user to program the current limit threshold between 275 mA to 2.7A (typical) through an external resistor.

This device incorporates an internal charge pump and the gate drive circuitry necessary to drive the N-channel MOSFET. The charge pump supplies power to the driver circuit and provides the necessary voltage to pull the gate of the MOSFET above the source. The charge pump operates from input voltages as low as 2.5 V and requires little supply current. The driver controls the gate voltage of the power switch. The driver incorporates circuitry that controls the rise and fall times of the output voltage to limit large current and voltage surges and provides built-in soft-start functionality.

The TPS25221 limits the output current to the current-limit threshold  $I_{OS}$  during an over-current or short-circuit event by reducing the charge pump voltage driving the N-channel MOSFET and operating it in the saturation region. The result of limiting the output current to  $I_{OS}$  reduces the output voltage at OUT because N-channel MOSFET is no longer fully enhanced (see [图 22](#)).

### 9.2 Functional Block Diagram

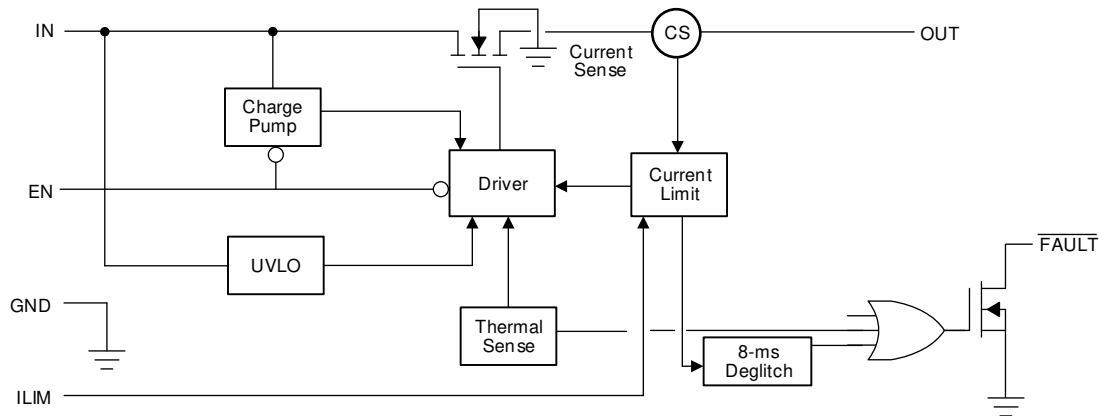

## 9.3 Feature Description

### 9.3.1 Over-current Conditions

The TPS25221 responds to over-current conditions by limiting output current to  $I_{OS}$  as show in 图 24. When an overload condition occurs, the device maintains a constant output current and the output voltage reduces accordingly. Two possible overload conditions can occur.

1. The first condition is when a short circuit or overload is present when the device is powered-up or enabled. The short circuit and overload holds the output near zero potential with respect to ground and the TPS25221 ramps the output current to  $I_{OS}$ . The TPS25221 limits the current to  $I_{OS}$  until the overload condition is removed or the device begins to thermal cycle.
2. The second condition is when a short circuit, partial short circuit, or transient overload occurs when the device is on and the internal NFET is fully enhanced. The device responds to the over-current condition by turning off the NFET within the time limit specified by  $t_{IOS}$  (see 图 4). The current-sense amplifier is over-driven during this time and momentarily disables the internal N-channel MOSFET. The current-sense amplifier then recovers and ramps the output current to  $I_{OS}$ . Similar to the previous case, the TPS25221 limits the current to  $I_{OS}$  until the overload condition is removed or the device begins to thermal cycle.

The TPS25221 thermal cycles if an overload condition is present long enough to activate thermal limiting in any of the above cases. Thermal limiting turns off the internal NFET and starts when the junction temperature exceeds 145°C (typical). The device remains off until the junction temperature cools 20°C (typical) and then restarts.

### 9.3.2 Fault Response

The  $\overline{\text{FAULT}}$  open-drain output is asserted (active low) during an over-current or over-temperature condition. The TPS25221 asserts the  $\overline{\text{FAULT}}$  signal until the fault condition is removed and the device resumes normal operation. The TPS25221 is designed to eliminate nuisance  $\overline{\text{FAULT}}$  reporting by using an internal 8 ms deglitch delay when reporting a fault. This ensures that  $\overline{\text{FAULT}}$  is not accidentally asserted due to normal transient conditions, such as starting into a heavy capacitive load. The deglitch circuitry delays asserting and de-asserting current limit induce FAULT reports. The FAULT signal is not deglitched when the MOSFET is disabled due to an over-temperature condition, but is deglitched after the device has cooled and begins to turn on. This unidirectional deglitch prevents  $\overline{\text{FAULT}}$  oscillation during an over-temperature event.

### 9.3.3 Undervoltage Lockout (UVLO)

The undervoltage lockout (UVLO) circuit disables the power switch until the input voltage reaches the UVLO turn-on threshold. Built-in hysteresis prevents unwanted on/off cycling due to input voltage droop during turn on.

### 9.3.4 Enable, (EN)

The logic enable controls the power switch and device supply current. The supply current is reduced to less than 0.5  $\mu\text{A}$ .

The TPS25221 is active high logic, when a logic low is present on EN, the part is disabled. A logic high input on EN enables the driver, control circuits, and power switch. The enable input is compatible with both TTL and CMOS logic levels.

### 9.3.5 Thermal Sense

The TPS25221 has self-protection features using two independent thermal-sensing circuits that monitor the operating temperature of the power switch and disable operation if the temperature exceeds the Over Temperature Shutdown Threshold (OTSD). The TPS25221 device operates in constant-current mode during overload conditions, which increases the voltage drop across power-switch. Power dissipation in the package is proportional to the voltage drop across the power switch, which increases the junction temperature during an over-current condition. The first thermal sensor turns off the power switch when the die temperature exceeds 145°C (typical) and the part is in current limit. Hysteresis is built into the thermal sensor, and the switch turns on after the device has cooled approximately 20°C (typical). The TPS25221 continues to cycle off and on until the fault condition is removed.

The ambient thermal sensor turns off the power-switch when the junction temperature exceeds 165°C (typical) in non-current limit condition. The part will turn the switch back on once the junction temperature has cooled approximately 20°C (typical).

## Feature Description (接下页)

The open-drain fault reporting output  $\overline{\text{FAULT}}$  is asserted (active low) immediately during an over-temperature shutdown condition.

## 9.4 Device Functional Modes

表 1. Protection Function Table

EVENT	CONDITION	ACTION
Overload on OUT	$I_{\text{LOAD}} > I_{\text{OS}}$	The device outputs $I_{\text{OS}} \times R_{\text{LOAD}}$ until thermal shutdown. The fault indicator asserts when the over-current condition persists for more 8 ms, the fault does not de-assert until over-current is removed and persists for 8 ms.
Overheating	$T_{\text{J}} > 165 \text{ C}$	The device immediately shuts off the internal power switch and the fault indicator asserts immediately when the junction temperature exceeds 165°C (typical). The device has a thermal hysteresis of 20°C (typical). The fault indicator de-asserts when the junction temperature falls below 145°C (typical).
Undervoltage on IN	$V_{\text{IN}} < 2.37 \text{ V}$	The device immediately shuts off the internal current-limited switch.

## 9.5 Programming

### 9.5.1 Programming the Current-Limit Threshold

The over-current threshold is user programmable through an external resistor. The TPS25221 uses an internal regulation loop to provide a regulated voltage on the ILIM pin. The current-limit threshold is proportional to the current sourced out of ILIM. The recommended 1% resistor range for  $R_{\text{ILIM}}$  is  $20 \text{ k}\Omega \leq R_{\text{ILIM}} \leq 210 \text{ k}\Omega$  to ensure stability of the internal regulation loop. Many applications require that the minimum current limit is above a certain current level or that the maximum current limit is below a certain current level, so it is important to consider the tolerance of the over-current threshold when selecting a value for  $R_{\text{ILIM}}$ . The following equations and 图 24 can be used to calculate the resulting over-current threshold for a given external resistor value ( $R_{\text{ILIM}}$ ). 图 24 includes current-limit tolerance due to variations caused by temperature and process. However, the equations do not account for tolerance due to external resistor variation, so it is important to account for this tolerance when selecting  $R_{\text{ILIM}}$ . The traces routing the  $R_{\text{ILIM}}$  resistor to the TPS25221 must be as short as possible to reduce parasitic effects on the current-limit accuracy.

$R_{\text{ILIM}}$  can be selected to provide a current-limit threshold that occurs: 1) above a minimum load current or 2) below a maximum load current.

To design above a minimum current-limit threshold, find the intersection of  $R_{\text{ILIM}}$  and the maximum desired load current on the  $I_{\text{OS}(\text{min})}$  curve and choose a value of  $R_{\text{ILIM}}$  below this value. Programming the current limit above a minimum threshold is important to ensure start-up into full load or heavy capacitive loads. The resulting maximum current-limit threshold is the intersection of the selected value of  $R_{\text{ILIM}}$  and the  $I_{\text{OS}(\text{max})}$  curve.

To design below a maximum current-limit threshold, find the intersection of  $R_{\text{ILIM}}$  and the maximum desired load current on the  $I_{\text{OS}(\text{max})}$  curve and choose a value of  $R_{\text{ILIM}}$  above this value. Programming the current limit below a maximum threshold is important to avoid current limiting upstream power supplies, causing the input voltage bus to droop. The resulting minimum current-limit threshold is the intersection of the selected value of  $R_{\text{ILIM}}$  and the  $I_{\text{OS}(\text{min})}$  curve.

Current-Limit Threshold Equation ( $I_{\text{OS}}$ ):

$$I_{\text{OSmax}} (\text{mA}) = \frac{52640\text{V}}{R_{\text{ILIM}}^{0.97} \text{k}\Omega}$$

$$I_{\text{OSnom}} (\text{mA}) = \frac{55960\text{V}}{R_{\text{ILIM}}^{1.004} \text{k}\Omega}$$

$$I_{\text{OSmin}} (\text{mA}) = \frac{56850\text{V}}{R_{\text{ILIM}}^{1.033} \text{k}\Omega}$$

where:

$$20 \text{ k}\Omega \leq R_{\text{ILIM}} \leq 210 \text{ k}\Omega.$$

(1)

Programming (接下页)



图 24. Current-Limit Threshold vs Current-Limit Resistor (R\_ILIM)

## 10 Application and Implementation

注

Information in the following applications sections is not part of the TI component specification, and TI does not warrant its accuracy or completeness. TI's customers are responsible for determining suitability of components for their purposes. Customers should validate and test their design implementation to confirm system functionality.

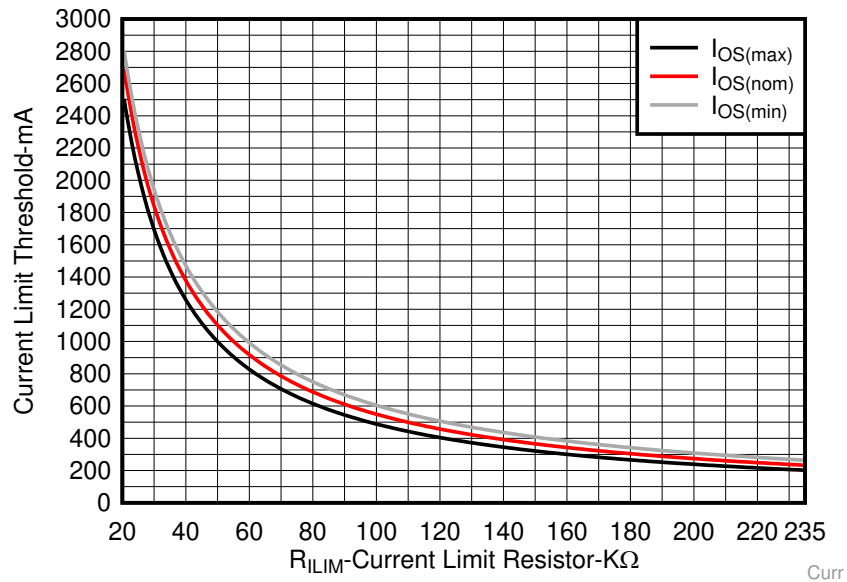
### 10.1 Application Information

#### 10.1.1 Constant-Current

During normal operation, the TPS25221 load current is less than the current-limit threshold and the device is not limiting current. During normal operation the N-channel MOSFET is fully enhanced, and  $V_{OUT} = V_{IN} - (I_{OUT} \times r_{DS(on)})$ . The voltage drop across the MOSFET is relatively small compared to  $V_{IN}$ , and  $V_{OUT}$  is approximately equal to  $V_{IN}$ .

The TPS25221 limits current to the programmed current-limit threshold, set by  $R_{ILIM}$ , reducing gate drive to the internal NFET, which increases  $R_{ds(on)}$  and reduces load current. This allows the device to effectively regulate the current to the current-limit threshold. Increasing the resistance of the MOSFET means that the voltage drop across the device is no longer negligible ( $V_{IN} \neq V_{OUT}$ ), and  $V_{OUT}$  decreases. The amount that  $V_{OUT}$  decreases is proportional to the magnitude of the overload condition. The expected  $V_{OUT}$  can be calculated by:

$$I_{OS} \times R_{LOAD}$$

where:

$$I_{OS} \text{ is the current-limit threshold and } R_{LOAD} \text{ is the magnitude of the overload condition.} \tag{2}$$

For example, if  $I_{OS}$  is programmed to 1 A and a 1 Ω overload condition is applied, the resulting  $V_{OUT}$  is 1 V.

While in current limit the power dissipation in the package can raise the die temperature above the thermal shutdown threshold (145°C typical), and the device turns off until the die temperature decreases by the hysteresis of the thermal shutdown circuit (20°C typical). The device then turns on and continues to thermal cycle until the overload condition is removed.

## 10.2 Typical Applications

### 10.2.1 Two-Level Current-Limit Circuit

Some applications require different current-limit thresholds depending on external system conditions. 图 25 shows an implementation for an externally controlled, two-level current-limit circuit. The current-limit threshold is set by the total resistance from ILIM to GND (see the [Programming the Current-Limit Threshold](#) section). A logic-level input enables or disables MOSFET Q1 and changes the current-limit threshold by modifying the total resistance from ILIM to GND. Additional MOSFET and resistor combinations can be used in parallel to Q1/R2 to increase the number of additional current-limit levels.



图 25. Two-Level Current-Limit Circuit

#### 10.2.1.1 Design Requirements

For this example, use the parameters shown in 表 2.

表 2. Design Requirements

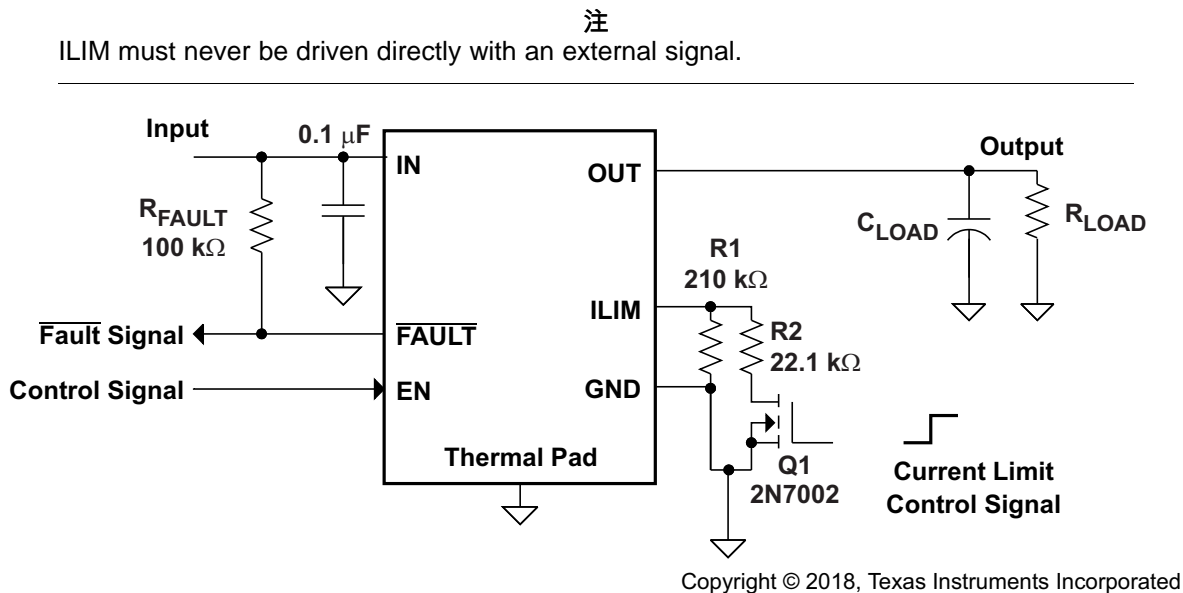
PARAMETER	VALUE
Input voltage	5 V
Output voltage	5 V
Above a minimum current limit	1000 mA
Below a maximum current limit	500 mA

#### 10.2.1.2 Detailed Design Procedures

##### 10.2.1.2.1 Designing Above a Minimum Current Limit

Some applications require that current limiting cannot occur below a certain threshold. For this example, assume that 1 A must be delivered to the load so that the minimum desired current-limit threshold is 1000 mA. Use the  $I_{OS}$  equations and 图 24 to select  $R_{ILIM}$ .

$$\begin{aligned}
 I_{OSmin} \text{ (mA)} &= 1000\text{mA} \\
 I_{OSmin} \text{ (mA)} &= \frac{56850\text{V}}{R_{ILIM}^{1.033}\text{k}\Omega} \\
 R_{ILIM} \text{ (k}\Omega) &= \left( \frac{56850\text{V}}{I_{OSmin}\text{mA}} \right)^{\frac{1}{1.033}} \\
 R_{ILIM} \text{ (k}\Omega) &= 50\text{k}\Omega
 \end{aligned} \tag{3}$$

Select the closest 1% resistor less than the calculated value:  $R_{ILIM} = 49.9 \text{ k}\Omega$ . This sets the minimum current-limit threshold at 1 A. Use the  $I_{OS}$  equations, [Figure 24](#), and the previously calculated value for  $R_{ILIM}$  to calculate the maximum resulting current-limit threshold.

$$\begin{aligned}
 R_{ILIM} \text{ (k}\Omega) &= 49.9\text{k}\Omega \\
 I_{OSmax} \text{ (mA)} &= \frac{52640\text{V}}{R_{ILIM}^{0.97}\text{k}\Omega} \\
 I_{OSmax} \text{ (mA)} &= \frac{52640\text{V}}{49.9^{0.97}\text{k}\Omega} \\
 I_{OSmax} \text{ (mA)} &= 1186\text{mA}
 \end{aligned} \tag{4}$$

The resulting maximum current-limit threshold is 1186 mA with a 49.9 k $\Omega$  resistor.

#### 10.2.1.2.2 Designing Below a Maximum Current Limit

Some applications require that current limiting must occur below a certain threshold. For this example, assume that the desired upper current-limit threshold must be below 500 mA to protect an up-stream power supply. Use the  $I_{OS}$  equations and [Figure 24](#) to select  $R_{ILIM}$ .

$$\begin{aligned}
 I_{OSmax} \text{ (mA)} &= 500\text{mA} \\
 I_{OSmax} \text{ (mA)} &= \frac{52640\text{V}}{R_{ILIM}^{0.97}\text{k}\Omega} \\
 R_{ILIM} \text{ (k}\Omega) &= \left( \frac{52640\text{V}}{I_{OSmax}\text{mA}} \right)^{\frac{1}{0.97}} \\
 R_{ILIM} \text{ (k}\Omega) &= 121.6\text{k}\Omega
 \end{aligned} \tag{5}$$

Select the closest 1% resistor greater than the calculated value:  $R_{ILIM} = 124 \text{ k}\Omega$ . This sets the maximum current-limit threshold at 500 mA. Use the  $I_{OS}$  equations, [Figure 24](#), and the previously calculated value for  $R_{ILIM}$  to calculate the minimum resulting current-limit threshold.

$$\begin{aligned}
 R_{ILIM} \text{ (k}\Omega) &= 124\text{k}\Omega \\
 I_{OSmin} \text{ (mA)} &= \frac{56850\text{V}}{R_{ILIM}^{1.033}\text{k}\Omega} \\
 I_{OSmin} \text{ (mA)} &= \frac{56850\text{V}}{124^{1.033}\text{k}\Omega} \\
 I_{OSmin} \text{ (mA)} &= 391\text{mA}
 \end{aligned} \tag{6}$$

The resulting minimum current-limit threshold is 391 mA with a 124 k $\Omega$  resistor.

#### 10.2.1.2.3 Accounting for Resistor Tolerance

The previous sections described the selection of  $R_{ILIM}$  given certain application requirements and the importance of understanding the current-limit threshold tolerance. The analysis focused only on TPS25221 performance and assumed an exact resistor value. However, resistors sold in quantity are not exact and are bounded by an upper and lower tolerance centered around a nominal resistance. The additional  $R_{ILIM}$  resistance tolerance directly affects the current-limit threshold accuracy at a system level. The following table shows a process that accounts

for worst-case resistor tolerance assuming 1% resistor values. Step one follows the selection process outlined in the application examples above. Step two determines the upper and lower resistance bounds of the selected resistor. Step three uses the upper and lower resistor bounds in the  $I_{OS}$  equations to calculate the threshold limits. It is important to use tighter tolerance resistors, for example, 0.5% or 0.1%, when precision current limiting is desired.

**表 3. Common  $R_{ILIM}$  Resistor Selections**

DESIRED NOMINAL CURRENT LIMIT (mA)	IDEAL RESISTOR (k $\Omega$ )	CLOSEST 1% RESISTOR (k $\Omega$ )	RESISTOR TOLERANCE		ACTUAL LIMITS		
			1% LOW (k $\Omega$ )	1% HIGH (k $\Omega$ )	$I_{OS(min)}$ (mA)	$I_{OS(nom)}$ (mA)	$I_{OS(max)}$ (mA)
275	199.2	200	198	202	236	274	312
400	137.2	137	135.6	138.4	349	401	450
500	109.8	110	108.9	111.1	438	499	556
600	91.6	90.9	90.0	91.8	533	605	669
700	78.6	78.7	77.9	79.5	619	699	770
800	68.8	68.1	67.4	68.8	719	808	886
900	61.2	61.9	61.3	62.5	793	889	972
1000	55.1	54.9	54.4	55.4	898	1003	1092
1200	45.9	46.4	45.9	46.9	1068	1188	1285
1400	39.4	39.2	38.8	39.6	1272	1407	1514
1600	34.5	34.8	34.5	35.1	1438	1585	1699
1800	30.7	30.9	30.6	31.2	1626	1786	1907
2000	27.6	27.4	27.1	27.7	1841	2015	2143
2200	25.1	24.9	24.7	25.1	2032	2219	2351
2400	23.0	23.2	23.0	23.4	2186	2382	2518
2600	21.3	21.5	21.3	21.7	2365	2571	2711
2700	20.5	20.5	20.3	20.7	2484	2697	2839

#### 10.2.1.2.4 Input and Output Capacitance

Input and output capacitance improves the performance of the device; the actual capacitance must be optimized for the particular application. For all applications, TI recommends placing a 0.1  $\mu$ F or greater ceramic bypass capacitor between IN and GND as close to the device as possible for local noise de-coupling. This precaution reduces ringing on the input due to power-supply transients. Additional input capacitance may be needed on the input to reduce voltage overshoot from exceeding the absolute maximum voltage of the device during heavy transient conditions. This is especially important during bench testing when long, inductive cables are used to connect the evaluation board to the bench power-supply.

TI recommends placing a high-value electrolytic capacitor on the output pin when large transient currents are expected on the output.

### 10.2.1.3 Application Curve

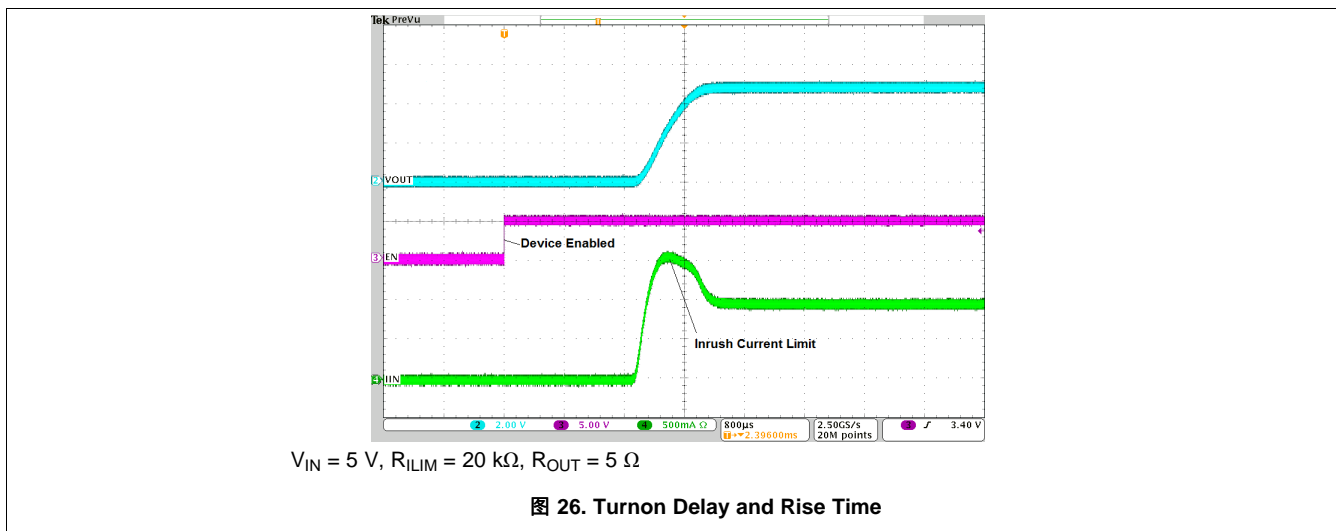

### 10.2.2 Auto-Retry Functionality

Some applications require that an over-current condition disables the part momentarily during a fault condition and re-enables after a pre-set time. This *auto-retry* functionality can be implemented with an external resistor and capacitor. During a fault condition,  $\overline{\text{FAULT}}$  pulls low disabling the part. The part is disabled when EN is pulled low, and  $\overline{\text{FAULT}}$  goes high impedance allowing  $C_{\text{RETRY}}$  to begin charging. The part re-enables when the voltage on EN reaches the turn-on threshold, and the auto-retry time is determined by the resistor-capacitor time constant. The device continues to cycle in this manner until the fault condition is removed.

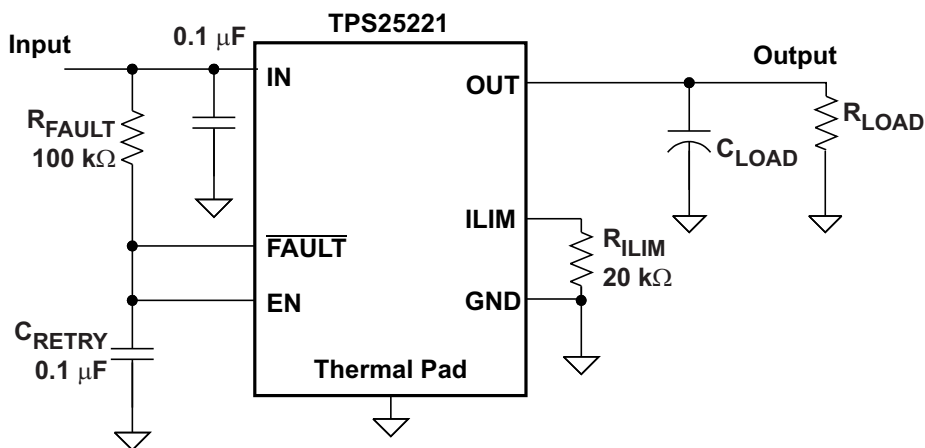

Copyright © 2018, Texas Instruments Incorporated

**图 27. Auto-Retry Functionality**

Some applications require auto-retry functionality and the ability to enable or disable with an external logic signal. [图 28](#) shows how an external logic signal can drive EN through  $R_{\text{FAULT}}$  and maintain auto-retry functionality. The resistor-capacitor time constant determines the auto-retry time-out period.

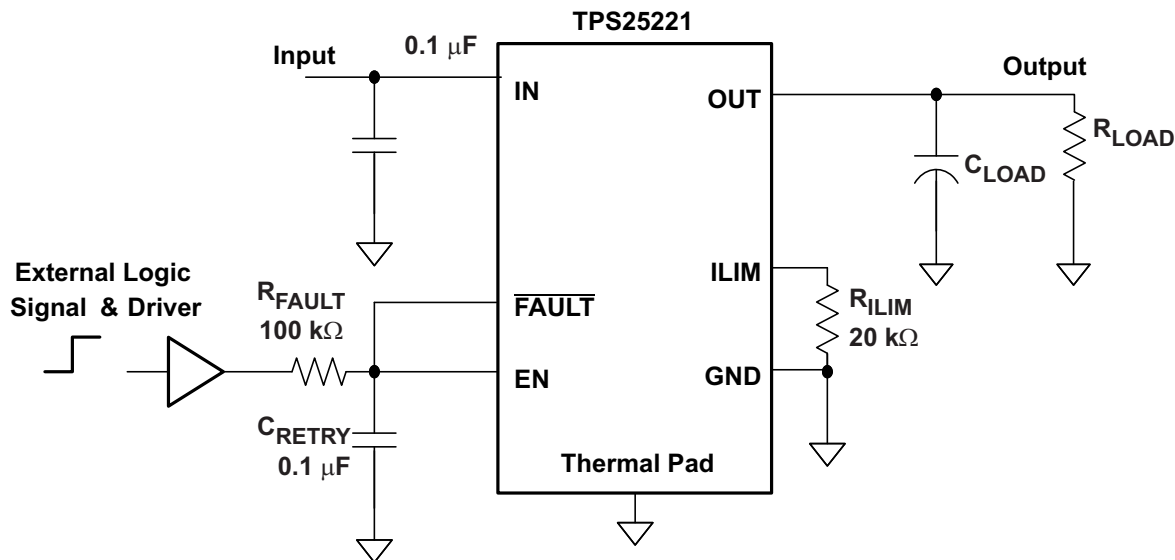

Copyright © 2018, Texas Instruments Incorporated

图 28. Auto-Retry Functionality With External EN Signal

10.2.2.1 Design Requirements (added)

For this example, use the parameters shown in 表 4.

表 4. Design Requirements

PARAMETER	VALUE
Input voltage	5 V
Output voltage	5 V
Above a minimum current limit	1000 mA
Below a maximum current limit	500 mA

10.2.2.2 Detailed Design Procedure

Refer to [Programming the Current-Limit Threshold](#) section for the current limit setting. For auto-retry functionality, once  $\overline{\text{FAULT}}$  asserted, EN pull low, TPS25221 is disabled,  $\overline{\text{FAULT}}$  des-asserted,  $C_{\text{RETRY}}$  is slowly charged to EN logic high through  $R_{\text{FAULT}}$ , then enable, after deglitch time,  $\overline{\text{FAULT}}$  asserted again. In the event of an overload, TPS25221 cycles and has output average current. ON-time with output current is decided by  $\overline{\text{FAULT}}$  deglitch time. OFF-time without output current is decided by  $R_{\text{FAULT}} \times C_{\text{RETRY}}$  constant time to EN logic high and  $t_{\text{on}}$  time. Therefore, set the  $R_{\text{FAULT}} \times C_{\text{RETRY}}$  to get the desired output average current during overload.

### 10.2.3 Typical Application as USB Power Switch

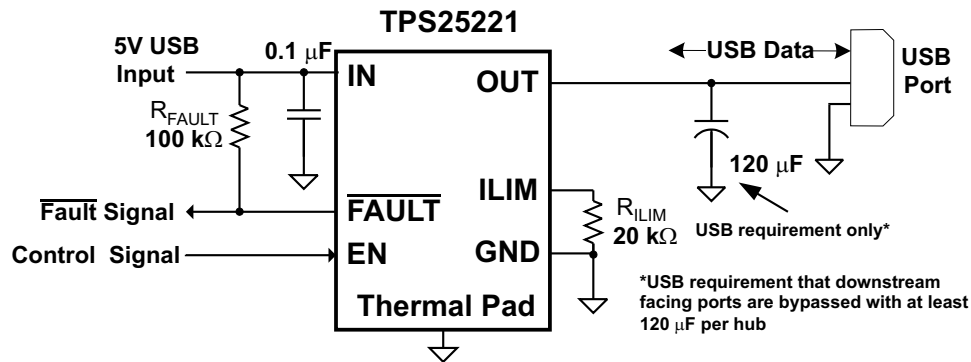

Copyright © 2018, Texas Instruments Incorporated

**图 29. Typical Application as USB Power Switch**

#### 10.2.3.1 Design Requirements

 For this example, use the parameters shown in [表 5](#).

**表 5. Design Requirements**

PARAMETER	VALUE
Input voltage	5 V
Output voltage	5 V
Current	1200 mA

##### 10.2.3.1.1 USB Power-Distribution Requirements

USB can be implemented in several ways regardless of the type of USB device being developed. Several power-distribution features must be implemented.

- Self Powered Hub (SPH) must:
  - Current limit downstream ports
  - Report over-current conditions
- Bus Powered Hub (BPH) must:
  - Enable or disable power to downstream ports
  - Power up at <100 mA
  - Limit inrush current (<44 Ω and 10 μF)
- Functions must:
  - Limit inrush currents
  - Power up at <100 mA

The feature set of the TPS25221 meets each of these requirements. The integrated current limiting and over-current reporting is required by self-powered hubs. The logic-level enable and controlled rise times meet the need of both input and output ports on bus-powered hubs and the input ports for bus-powered functions.

#### 10.2.3.2 Detailed Design Procedure

##### 10.2.3.2.1 Universal Serial Bus (USB) Power-Distribution Requirements

One application for this device is for current limiting in universal serial bus (USB) applications. The original USB interface was a 12-Mbps or 1.5-Mbps, multiplexed serial bus designed for low-to-medium bandwidth PC peripherals (for example, keyboards, printers, scanners, and mice). As the demand for more bandwidth increased, the USB 2.0 standard was introduced increasing the maximum data rate to 480 Mbps. The four-wire USB interface is conceived for dynamic attach-detach (hot plug-unplug) of peripherals. Two lines are provided for differential data, and two lines are provided for 5-V power distribution.

USB data is a 3.3-V level signal, but power is distributed at 5 V to allow for voltage drops in cases where power is distributed through more than one hub across long cables. Each function must provide its own regulated 3.3 V from the 5-V input or its own internal power supply. The USB specification classifies two different classes of devices depending on its maximum current draw. A device classified as low-power can draw up to 100 mA as defined by the standard. A device classified as high-power can draw up to 500 mA. It is important that the minimum current-limit threshold of the current-limiting power-switch exceed the maximum current-limit draw of the intended application. The latest USB standard must always be referenced when considering the current-limit threshold.

The USB specification defines two types of devices as hubs and functions. A USB hub is a device that contains multiple ports for different USB devices to connect and can be self-powered (SPH) or bus-powered (BPH). A function is a USB device that is able to transmit or receive data or control information over the bus. A USB function can be embedded in a USB hub. A USB function can be one of three types included in the list below.

- Low-power, bus-powered function
- High-power, bus-powered function
- Self-powered function

SPHs and BPHs distribute data and power to downstream functions. The TPS25221 has higher current capability than required for a single USB port allowing it to power multiple downstream ports.

## 11 Power Supply Recommendations

### 11.1 Self-Powered and Bus-Powered Hubs

A SPH has a local power supply that powers embedded functions and downstream ports. This power supply must provide between 4.75 V to 5.25 V to downstream facing devices under full-load and no-load conditions. SPHs are required to have current-limit protection and must report over-current conditions to the USB controller. Typical SPHs are desktop PCs, monitors, printers, and stand-alone hubs.

A BPH obtains all power from an upstream port and often contains an embedded function. It must power up with less than 100 mA. The BPH usually has one embedded function, and power is always available to the controller of the hub. If the embedded function and hub require more than 100 mA on power up, keep the power to the embedded function off until enumeration is completed. This can be accomplished by removing power or by shutting off the clock to the embedded function. Power-switching the embedded function is not necessary if the aggregate power draw for the function and controller is less than 100 mA. The total current drawn by the bus-powered device is the sum of the current to the controller, the embedded function, and the downstream ports, and it is limited to 500 mA from an upstream port.

### 11.2 Low-Power Bus-Powered and High-Power Bus-Powered Functions

Both low-power and high-power bus-powered functions obtain all power from upstream ports. Low-power functions always draw less than 100 mA; high-power functions must draw less than 100 mA at power up and can draw up to 500 mA after enumeration. If the load of the function is more than the parallel combination of 44  $\Omega$  and 10  $\mu\text{F}$  at power up, the device must implement inrush current limiting.

### 11.3 Power Dissipation and Junction Temperature

The low ON-resistance of the N-channel MOSFET allows small surface-mount packages to pass large currents. It is required design practice to determine power dissipation and junction temperature. The below analysis gives an approximation for calculating junction temperature based on the power dissipation in the package. However, it is important to note that thermal analysis is strongly dependent on additional system level factors. Such factors include air flow, board layout, copper thickness and surface area, and proximity to other devices dissipating power. Good thermal design practice must include all system level factors in addition to individual component analysis.

Begin by determining the  $r_{\text{DS(on)}}$  of the N-channel MOSFET relative to the input voltage and operating temperature. As an initial estimate, use the highest operating ambient temperature expected and read  $r_{\text{DS(on)}}$  from the typical characteristics graph. Using this value, the power dissipation can be calculated using [公式 7](#):

## Power Dissipation and Junction Temperature (接下页)

$$P_D = r_{DS(on)} \times I_{OUT}^2$$

where

- $P_D$  = Total power dissipation (W)
- $r_{DS(on)}$  = Power switch on-resistance ( $\Omega$ )
- $I_{OUT}$  = Maximum current-limit threshold (A)
- This step calculates the total power dissipation of the N-channel MOSFET. (7)

Finally, calculate the junction temperature:

$$T_J = P_D \times \theta_{JA} + T_A$$

where

- $T_A$  = Ambient temperature ( $^{\circ}\text{C}$ )
- $\theta_{JA}$  = Thermal resistance ( $^{\circ}\text{C}/\text{W}$ )
- $P_D$  = Total power dissipation (W) (8)

Compare the calculated junction temperature with the initial estimate. If they are not within a few degrees, repeat the calculation using the *refined*  $r_{DS(on)}$  from the previous calculation as the new estimate. Two or three iterations are generally sufficient to achieve the desired result. The final junction temperature is highly dependent on thermal resistance  $\theta_{JA}$ , and thermal resistance is highly dependent on the individual package and board layout. The table provides example thermal resistances for specific packages and board layouts.

## 12 Layout

### 12.1 Layout Guidelines

- TI recommends placing the 100-nF bypass capacitor near the IN and GND pins, and make the connections using a low-inductance trace.
- TI recommends placing a high-value electrolytic capacitor and a 100-nF bypass capacitor on the output pin when large transient currents are expected on the output.
- The traces routing the RILIM resistor to the device must be as short as possible to reduce parasitic effects on the current limit accuracy.
- The thermal pad must be directly connected to PCB ground plane using wide and short copper trace.

### 12.2 Layout Example



图 30. TPS25221DBV Board Layout



图 31. TPS25221DRV Board Layout

## 13 器件和文档支持

### 13.1 器件支持

#### 13.1.1 第三方产品免责声明

TI 发布的与第三方产品或服务有关的信息，不能构成与此类产品或服务或保修的适用性有关的认可，不能构成此类产品或服务单独或与任何 TI 产品或服务一起的表示或认可。

### 13.2 文档支持

#### 13.2.1 相关文档

请参阅如下相关文档：

- 《TPS25221 评估模块用户指南》(SLVUBD1)

### 13.3 接收文档更新通知

要接收文档更新通知，请导航至 [ti.com](http://ti.com) 上的器件产品文件夹。单击右上角的通知我进行注册，即可每周接收产品信息更改摘要。有关更改的详细信息，请查看任何已修订文档中包含的修订历史记录。

### 13.4 社区资源

TI E2E™ support forums are an engineer's go-to source for fast, verified answers and design help — straight from the experts. Search existing answers or ask your own question to get the quick design help you need.

Linked content is provided "AS IS" by the respective contributors. They do not constitute TI specifications and do not necessarily reflect TI's views; see TI's [Terms of Use](#).

### 13.5 商标

E2E is a trademark of Texas Instruments.

### 13.6 静电放电警告



ESD 可能会损坏该集成电路。德州仪器 (TI) 建议通过适当的预防措施处理所有集成电路。如果不遵守正确的处理措施和安装程序，可能会损坏集成电路。

ESD 的损坏小至导致微小的性能降级，大至整个器件故障。精密的集成电路可能更容易受到损坏，这是因为非常细微的参数更改都可能会导致器件与其发布的规格不相符。

### 13.7 Glossary

[SLYZ022](#) — TI Glossary.

This glossary lists and explains terms, acronyms, and definitions.

## 14 机械、封装和可订购信息

以下页面包含机械、封装和可订购信息。这些信息是指定器件的最新可用数据。数据如有变更，恕不另行通知，且不会对此文档进行修订。如需获取此数据表的浏览器版本，请查阅左侧的导航栏。

**PACKAGING INFORMATION**

Orderable Device	Status (1)	Package Type	Package Drawing	Pins	Package Qty	Eco Plan (2)	Lead finish/ Ball material (6)	MSL Peak Temp (3)	Op Temp (°C)	Device Marking (4/5)	Samples
TPS25221DBVR	ACTIVE	SOT-23	DBV	6	3000	RoHS & Green	NIPDAU	Level-1-260C-UNLIM	-40 to 125	1B4F	<a href="#">Samples</a>
TPS25221DBVT	ACTIVE	SOT-23	DBV	6	250	RoHS & Green	NIPDAU	Level-1-260C-UNLIM	-40 to 125	1B4F	<a href="#">Samples</a>
TPS25221DRVR	ACTIVE	WSON	DRV	6	3000	RoHS & Green	NIPDAU	Level-1-260C-UNLIM	-40 to 125	1C7H	<a href="#">Samples</a>
TPS25221DRVT	ACTIVE	WSON	DRV	6	250	RoHS & Green	NIPDAU	Level-1-260C-UNLIM	-40 to 125	1C7H	<a href="#">Samples</a>

(1) The marketing status values are defined as follows:

**ACTIVE:** Product device recommended for new designs.

**LIFEBUY:** TI has announced that the device will be discontinued, and a lifetime-buy period is in effect.

**NRND:** Not recommended for new designs. Device is in production to support existing customers, but TI does not recommend using this part in a new design.

**PREVIEW:** Device has been announced but is not in production. Samples may or may not be available.

**OBSOLETE:** TI has discontinued the production of the device.

(2) **RoHS:** TI defines "RoHS" to mean semiconductor products that are compliant with the current EU RoHS requirements for all 10 RoHS substances, including the requirement that RoHS substance do not exceed 0.1% by weight in homogeneous materials. Where designed to be soldered at high temperatures, "RoHS" products are suitable for use in specified lead-free processes. TI may reference these types of products as "Pb-Free".

**RoHS Exempt:** TI defines "RoHS Exempt" to mean products that contain lead but are compliant with EU RoHS pursuant to a specific EU RoHS exemption.

**Green:** TI defines "Green" to mean the content of Chlorine (Cl) and Bromine (Br) based flame retardants meet JS709B low halogen requirements of <=1000ppm threshold. Antimony trioxide based flame retardants must also meet the <=1000ppm threshold requirement.

(3) **MSL, Peak Temp.** - The Moisture Sensitivity Level rating according to the JEDEC industry standard classifications, and peak solder temperature.

(4) There may be additional marking, which relates to the logo, the lot trace code information, or the environmental category on the device.

(5) Multiple Device Markings will be inside parentheses. Only one Device Marking contained in parentheses and separated by a "-" will appear on a device. If a line is indented then it is a continuation of the previous line and the two combined represent the entire Device Marking for that device.

(6) **Lead finish/Ball material** - Orderable Devices may have multiple material finish options. Finish options are separated by a vertical ruled line. Lead finish/Ball material values may wrap to two lines if the finish value exceeds the maximum column width.

**Important Information and Disclaimer:**The information provided on this page represents TI's knowledge and belief as of the date that it is provided. TI bases its knowledge and belief on information provided by third parties, and makes no representation or warranty as to the accuracy of such information. Efforts are underway to better integrate information from third parties. TI has taken and

continues to take reasonable steps to provide representative and accurate information but may not have conducted destructive testing or chemical analysis on incoming materials and chemicals. TI and TI suppliers consider certain information to be proprietary, and thus CAS numbers and other limited information may not be available for release.

In no event shall TI's liability arising out of such information exceed the total purchase price of the TI part(s) at issue in this document sold by TI to Customer on an annual basis.

**TAPE AND REEL INFORMATION**

**QUADRANT ASSIGNMENTS FOR PIN 1 ORIENTATION IN TAPE**

\*All dimensions are nominal

Device	Package Type	Package Drawing	Pins	SPQ	Reel Diameter (mm)	Reel Width W1 (mm)	A0 (mm)	B0 (mm)	K0 (mm)	P1 (mm)	W (mm)	Pin1 Quadrant
TPS25221DBVR	SOT-23	DBV	6	3000	180.0	8.4	3.23	3.17	1.37	4.0	8.0	Q3
TPS25221DBVR	SOT-23	DBV	6	3000	180.0	8.4	3.2	3.2	1.4	4.0	8.0	Q3
TPS25221DBVT	SOT-23	DBV	6	250	180.0	8.4	3.23	3.17	1.37	4.0	8.0	Q3
TPS25221DBVT	SOT-23	DBV	6	250	180.0	8.4	3.2	3.2	1.4	4.0	8.0	Q3
TPS25221DRVR	WSON	DRV	6	3000	180.0	8.4	2.3	2.3	1.15	4.0	8.0	Q2
TPS25221DRVT	WSON	DRV	6	250	180.0	8.4	2.3	2.3	1.15	4.0	8.0	Q2

**TAPE AND REEL BOX DIMENSIONS**

\*All dimensions are nominal

Device	Package Type	Package Drawing	Pins	SPQ	Length (mm)	Width (mm)	Height (mm)
TPS25221DBVR	SOT-23	DBV	6	3000	183.0	183.0	20.0
TPS25221DBVR	SOT-23	DBV	6	3000	210.0	185.0	35.0
TPS25221DBVT	SOT-23	DBV	6	250	183.0	183.0	20.0
TPS25221DBVT	SOT-23	DBV	6	250	210.0	185.0	35.0
TPS25221DRVR	WSON	DRV	6	3000	210.0	185.0	35.0
TPS25221DRVT	WSON	DRV	6	250	210.0	185.0	35.0

DBV0006A



# PACKAGE OUTLINE

SOT-23 - 1.45 mm max height

SMALL OUTLINE TRANSISTOR

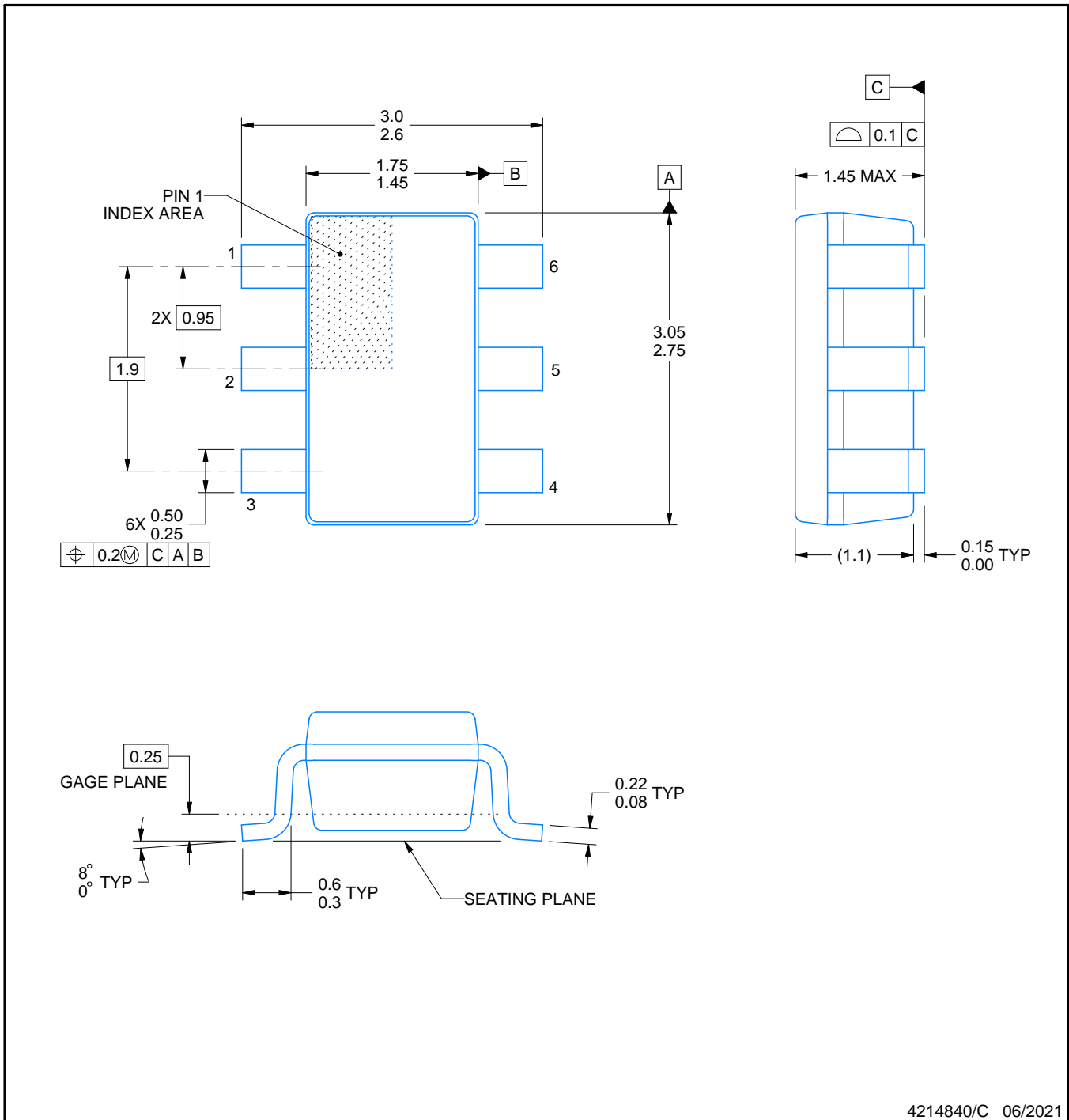

4214840/C 06/2021

## NOTES:

1. All linear dimensions are in millimeters. Any dimensions in parenthesis are for reference only. Dimensioning and tolerancing per ASME Y14.5M.
2. This drawing is subject to change without notice.
3. Body dimensions do not include mold flash or protrusion. Mold flash and protrusion shall not exceed 0.25 per side.
4. Leads 1,2,3 may be wider than leads 4,5,6 for package orientation.
5. Reference JEDEC MO-178.

# EXAMPLE BOARD LAYOUT

DBV0006A

SOT-23 - 1.45 mm max height

SMALL OUTLINE TRANSISTOR

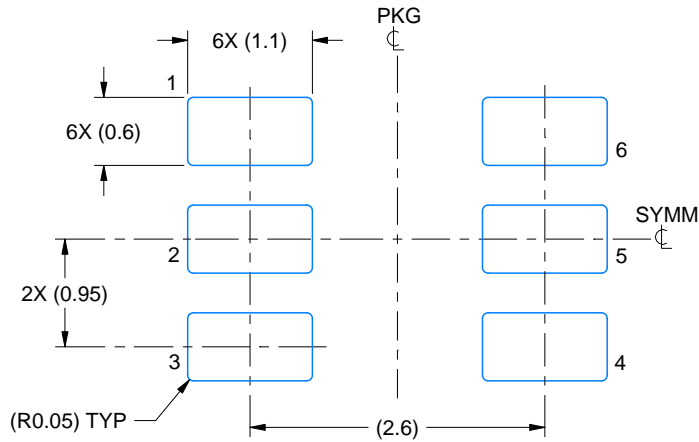

LAND PATTERN EXAMPLE  
EXPOSED METAL SHOWN  
SCALE:15X

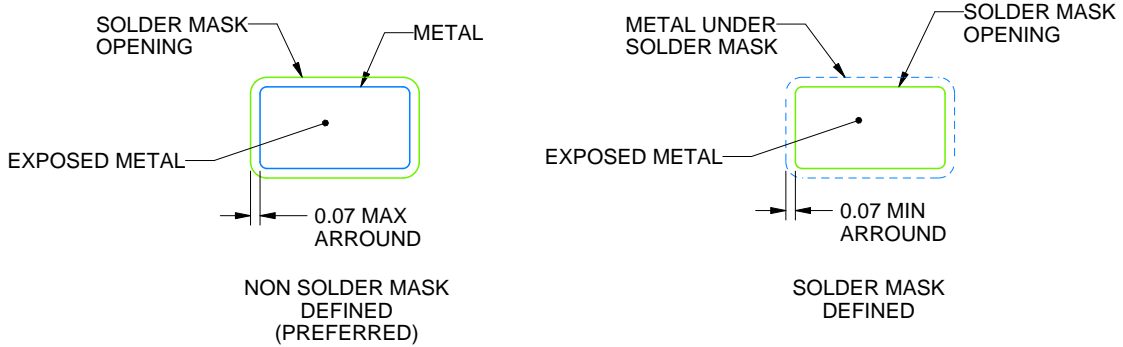

SOLDER MASK DETAILS

4214840/C 06/2021

NOTES: (continued)

- 6. Publication IPC-7351 may have alternate designs.
- 7. Solder mask tolerances between and around signal pads can vary based on board fabrication site.

# EXAMPLE STENCIL DESIGN

DBV0006A

SOT-23 - 1.45 mm max height

SMALL OUTLINE TRANSISTOR

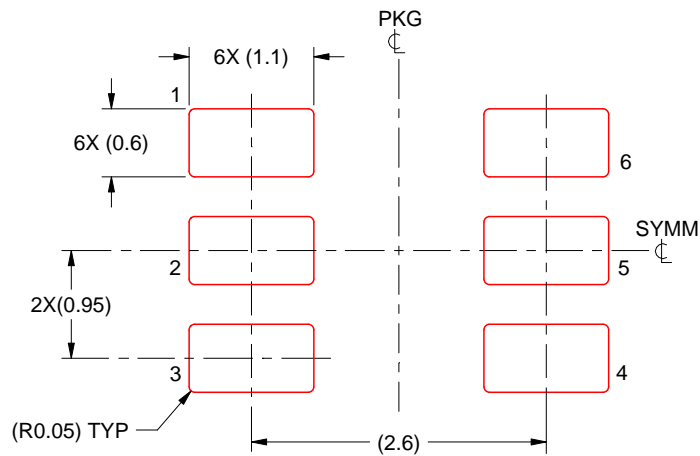

SOLDER PASTE EXAMPLE  
BASED ON 0.125 mm THICK STENCIL  
SCALE:15X

4214840/C 06/2021

NOTES: (continued)

8. Laser cutting apertures with trapezoidal walls and rounded corners may offer better paste release. IPC-7525 may have alternate design recommendations.
9. Board assembly site may have different recommendations for stencil design.

## GENERIC PACKAGE VIEW

DRV 6

WSON - 0.8 mm max height

PLASTIC SMALL OUTLINE - NO LEAD



Images above are just a representation of the package family, actual package may vary.  
Refer to the product data sheet for package details.

4206925/F



4222173/B 04/2018

NOTES:

1. All linear dimensions are in millimeters. Any dimensions in parenthesis are for reference only. Dimensioning and tolerancing per ASME Y14.5M.
2. This drawing is subject to change without notice.
3. The package thermal pad must be soldered to the printed circuit board for thermal and mechanical performance.

# EXAMPLE BOARD LAYOUT

DRV0006A

WSON - 0.8 mm max height

PLASTIC SMALL OUTLINE - NO LEAD



LAND PATTERN EXAMPLE  
SCALE:25X

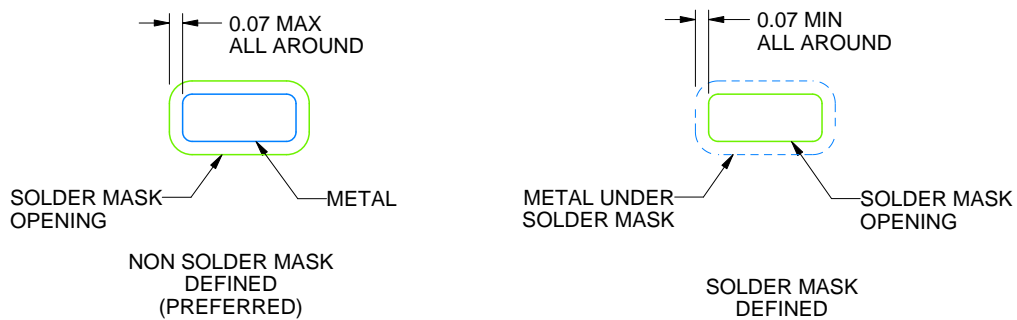

SOLDER MASK DETAILS

4222173/B 04/2018

NOTES: (continued)

4. This package is designed to be soldered to a thermal pad on the board. For more information, see Texas Instruments literature number SLUA271 ([www.ti.com/lit/sluea271](http://www.ti.com/lit/sluea271)).
5. Vias are optional depending on application, refer to device data sheet. If some or all are implemented, recommended via locations are shown.

# EXAMPLE STENCIL DESIGN

DRV0006A

WSON - 0.8 mm max height

PLASTIC SMALL OUTLINE - NO LEAD



SOLDER PASTE EXAMPLE  
BASED ON 0.125 mm THICK STENCIL

EXPOSED PAD #7  
88% PRINTED SOLDER COVERAGE BY AREA UNDER PACKAGE  
SCALE:30X

4222173/B 04/2018

NOTES: (continued)

6. Laser cutting apertures with trapezoidal walls and rounded corners may offer better paste release. IPC-7525 may have alternate design recommendations.

## 重要声明和免责声明

TI 提供技术和可靠性数据（包括数据表）、设计资源（包括参考设计）、应用或其他设计建议、网络工具、安全信息和其他资源，不保证没有瑕疵且不做任何明示或暗示的担保，包括但不限于对适销性、某特定用途方面的适用性或不侵犯任何第三方知识产权的暗示担保。

这些资源可供使用 TI 产品进行设计的熟练开发人员使用。您将自行承担以下全部责任：(1) 针对您的应用选择合适的 TI 产品，(2) 设计、验证并测试您的应用，(3) 确保您的应用满足相应标准以及任何其他安全、安保或其他要求。这些资源如有变更，恕不另行通知。TI 授权您仅可将这些资源用于研发本资源所述的 TI 产品的应用。严禁对这些资源进行其他复制或展示。您无权使用任何其他 TI 知识产权或任何第三方知识产权。您应全额赔偿因在这些资源的使用中对 TI 及其代表造成的任何索赔、损害、成本、损失和债务，TI 对此概不负责。

TI 提供的产品受 TI 的销售条款 (<https://www.ti.com.cn/zh-cn/legal/termsofsale.html>) 或 [ti.com.cn](https://www.ti.com.cn) 上其他适用条款/TI 产品随附的其他适用条款的约束。TI 提供这些资源并不会扩展或以其他方式更改 TI 针对 TI 产品发布的适用的担保或担保免责声明。

邮寄地址：上海市浦东新区世纪大道 1568 号中建大厦 32 楼，邮政编码：200122

Copyright © 2021 德州仪器半导体技术（上海）有限公司