

# 具有电缆补偿的 TPS2583x-Q1 USB Type-C® 和 BC1.2 5V 3.5A 输出、36V 输入 同步降压直流/直流稳压器

## 1 特性

- 符合面向汽车应用的 AEC-Q100 标准：
  - 温度等级 1：-40°C 至 +125°C，T<sub>A</sub>
  - HBM ESD 分类等级 H2
  - CDM ESD 分类等级 C5
- 提供功能安全
  - 可帮助进行功能安全系统设计的文档
- 同步降压直流/直流稳压器
  - 输入电压范围：4.5V 至 36V
  - 输出电流：3.5A
  - 5.1V 输出电压，精度为 ±1%
  - 电流模式控制
  - 频率可调节：300kHz 至 2.2MHz
  - 与外部时钟频率同步
  - 具有扩频频谱抖动的 FPWM
  - 内置补偿功能，便于使用
- 符合 USB-IF 标准
  - USB Type-C® 1.3 版
    - CC 逻辑、V<sub>CONN</sub> 拉电流和放电电流
    - USB 电缆极性保护 (POL)
  - 符合 USB BC1.2 规范的 CDP/SDP 模式
  - 自动 DCP 模式 (仅 TPS25831-Q1)
    - DCP 短路模式和 YD/T 1591-2009
    - 2.7V 分压器 3 模式
    - 1.2V 模式
- 针对 USB 电源和通信进行了优化
  - 用户可编程的 USB 电流限制
  - 高达 1.5V 的电缆压降补偿
  - DP 和 DM 上的高带宽数据开关 (仅 TPS25830-Q1)
  - 用于智能热管理的 NTC 输入 (仅 TPS25831-Q1)
- 集成式保护

- V<sub>BUS</sub> 对 V<sub>BAT</sub> 短路保护
- DP\_IN 和 DM\_IN 对 V<sub>BAT</sub> 和 V<sub>BUS</sub> 短路保护
- CC1 和 CC2 线对 V<sub>BAT</sub> 短路保护
- 符合 CCx IEC 61000-4-2 标准的 DP\_IN、DM\_IN
  - ±8kV 接触放电和 ±15kV 空气放电
- 故障标志报告
- 具有可湿性侧面的 32 引脚 QFN 封装

## 2 应用

- 汽车信息娱乐系统
- USB 媒体中心
- USB 充电器端口

## 3 说明

TPS2583x-Q1 是一款 USB Type-C 和 BC1.2 充电端口控制器，包含一个同步直流/直流转换器。凭借电缆压降补偿，不管负载电流如何变化，V<sub>BUS</sub> 电压都保持恒定，确保能以最佳电流和电压为连接的便携式设备充电。

TPS2583x-Q1 还在 V<sub>BUS</sub>、CC1、CC2、DM\_IN 和 DP\_IN 引脚上集成了电池短路保护。这些引脚可承受最高 18V 的电压。

TPS25830-Q1 包括可实现 DP 和 DM 直通的高带宽模拟开关，而 TPS25831-Q1 包括热敏电阻输入引脚和用于实现用户可编程热过载保护的热警告标志。

### 器件信息(1)

器件型号	封装	封装尺寸 (标称值)
TPS25830-Q1	VQFN (32)	5.00mm × 5.00mm
TPS25831-Q1	VQFN (32)	5.00mm × 5.00mm

- (1) 如需了解所有不同可选件的详细器件型号，请参阅产品说明书末尾的可订购产品附录。

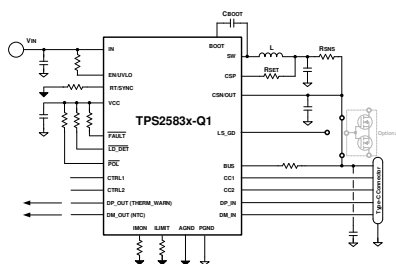

TPS2583x-Q1 简化版原理图

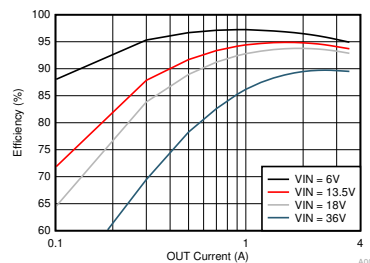

降压效率与输出电流间的关系 (f<sub>sw</sub> = 400kHz)



## Table of Contents

1 特性.....	1	10.3 Feature Description.....	26
2 应用.....	1	10.4 Device Functional Modes.....	50
3 说明.....	1	<b>11 Application and Implementation.....</b>	<b>54</b>
4 Revision History.....	2	11.1 Application Information.....	54
5 说明 (续).....	4	11.2 Typical Application.....	54
6 Device Comparison Table.....	4	<b>12 Power Supply Recommendations.....</b>	<b>66</b>
7 Pin Configuration and Functions.....	5	<b>13 Layout.....</b>	<b>66</b>
8 Specifications.....	8	13.1 Layout Guidelines.....	66
8.1 Absolute Maximum Ratings.....	8	13.2 Ground Plane and Thermal Considerations.....	67
8.2 ESD Ratings.....	9	13.3 Layout Example.....	68
8.3 Recommended Operating Conditions.....	9	<b>14 Device and Documentation Support.....</b>	<b>69</b>
8.4 Thermal Information.....	10	14.1 Related Links.....	69
8.5 Electrical Characteristics.....	10	14.2 接收文档更新通知.....	69
8.6 Timing Requirements.....	15	14.3 支持资源.....	69
8.7 Switching Characteristics.....	15	14.4 Trademarks.....	69
8.8 Typical Characteristics.....	18	14.5 Electrostatic Discharge Caution.....	69
9 Parameter Measurement Information.....	24	14.6 术语表.....	69
10 Detailed Description.....	25	<b>15 Mechanical, Packaging, and Orderable Information.....</b>	<b>69</b>
10.1 Overview.....	25		
10.2 Functional Block Diagram.....	26		

## 4 Revision History

注：以前版本的页码可能与当前版本的页码不同

<b>Changes from Revision F (August 2020) to Revision G (July 2021)</b>	<b>Page</b>
• Added RHB0032V package to the data sheet.....	5
<b>Changes from Revision E (May 2020) to Revision F (August 2020)</b>	<b>Page</b>
• 更新了整个文档中的表格、图和交叉参考的编号格式.....	1
• 向 <a href="#">特性</a> 部分添加了功能安全链接.....	1
<b>Changes from Revision D (September 2019) to Revision E (May 2020)</b>	<b>Page</b>
• Update PCB layout and guideline, EMC friendly .....	66
<b>Changes from Revision C (July 2019) to Revision D (September 2019)</b>	<b>Page</b>
• Changed the High-Bandwidth Analog Switch RDS_ON MAX from 5.6 to 6.3 and from 6.8 to 7.7 in the <a href="#">Specifications Electrical Characteristics</a> table.....	8
• Added content for the TPS25830-Q1 timing requirement and <a href="#">图 10-5</a> in the <a href="#">Enable/UVLO and Start-up</a> section.....	27
• Updated the LS_GD requirements in the <a href="#">Current Limit Setting using R<sub>ILIMIT</sub></a> section.....	34
<b>Changes from Revision B (June 2019) to Revision C (July 2019)</b>	<b>Page</b>
• 将 TPS25830-Q1 更改为“量产数据” .....	1
• Changed Supply Voltage (IN PIN) IQ from 800 to 990 in the <a href="#">Specifications Electrical Characteristics</a> table.....	8
<b>Changes from Revision A (November 2018) to Revision B (May 2019)</b>	<b>Page</b>
• 将 TPS25831-Q1 从“预告信息”更改为“量产数据” .....	1

---

**Changes from Revision \* (June 2018) to Revision A (November 2018)**

**Page**

- 将器件状态从“产品预发布”改为“预告信息” ..... **1**
-

## 5 说明 (续)

此同步降压稳压器具有电流模式控制并采用内部补偿，因此简化了设计。RT 引脚上有一个电阻器，可用于在 300kHz 和 2.2MHz 之间设置开关频率。在低于 400kHz 的频率下运行可实现更高的系统效率。在高于 2.1MHz 的频率下运行则可以避开 AM 无线电频段，并且能够使用较小的电感器。

TPS2583x-Q1 集成了标准 USB Type-C 端口控制器功能，包括用于 3A 和 1.5A 电流广播的配置通道 (CC) 逻辑。电池充电 (1.2 版) 集成提供了利用 USB 数据线信号来确定 USB 端口拉电流能力的传统非 Type-C USB 器件所需的电气特性。

内含一个精密电流感应放大器，用于实现用户可编程电缆压降补偿和电流限制调整。电缆补偿可使降压稳压器输出电压随负载电流线性改变，以抵消由于汽车电缆布线中的导线电阻引起的压降，从而帮助便携式设备在重载下实现最佳电流和电压充电。不管负载电流如何变化，在连接的便携式设备上测得的  $V_{BUS}$  电压都保持大致恒定，这使得便携式设备的电池充电器能够保持最佳工作状态。

USB 规范要求 USB 充电端口满足电流限制，但也留下了合理的自由空间，允许系统设计人员基于系统要求选择过流保护级别。TPS25830x-Q1 使用了一种新颖的双阈值电流限制电路，允许系统设计人员对降压稳压器的平均电流限制保护进行编程，或者在 CSN/OUT 和 BUS 引脚之间使用外部 NMOS 来对电流限制进行调整。由于实施了 NFET，TPS2583x-Q1 降压稳压器可在 USB 端口上存在过流故障期间为其他负载提供 5V 输出。

TPS25830-Q1 包括可实现 DP 和 DM 直通的高带宽模拟开关。TPS25831-Q1 包括热敏电阻输入引脚和用于实现用户可编程热过载保护的热警告标志。

集成保护特性包括逐周期电流限制、断续短路保护、欠压锁定、 $V_{BUS}$  过压和过流、CC 过压和过流、数据线 ( $D_x$ ) 对  $V_{BUS}$  和  $V_{BAT}$  短路以及裸片过热保护。

## 6 Device Comparison Table

PART NUMBER	PACKAGE	DCP AUTO	DP AND DM SWITCHES	NTC INPUT	THERMAL WARNING FLAG
TPS25830-Q1	VQFN (32)	No	Yes	No	No
TPS25831-Q1	VQFN (32)	Yes	No	Yes	Yes

## 7 Pin Configuration and Functions

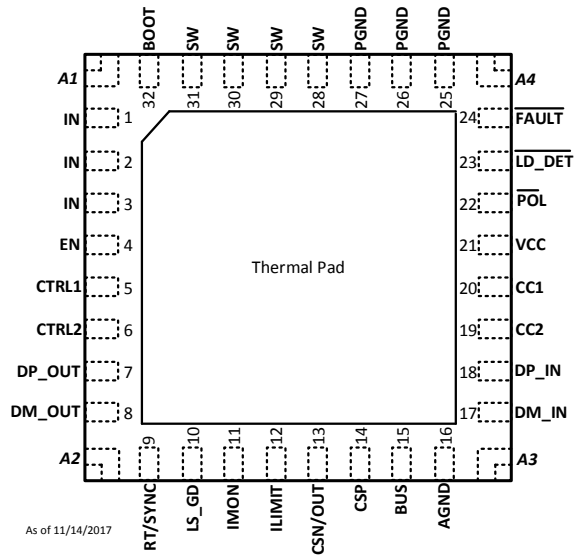

NOTES:

- 1) A1, A2, A3, and A4 are corner anchors for enhanced package stress performance.
- 2) A1, A2, A3, and A4 are electrically connected to the thermal pad.
- 3) A1, A2, A3, and A4 PCB lands should be electrically isolated or electrically connected to thermal pad and PGND.

**图 7-1. TPS25830QWRHBRQ1 Package 32-Pin (VQFN) Top View**

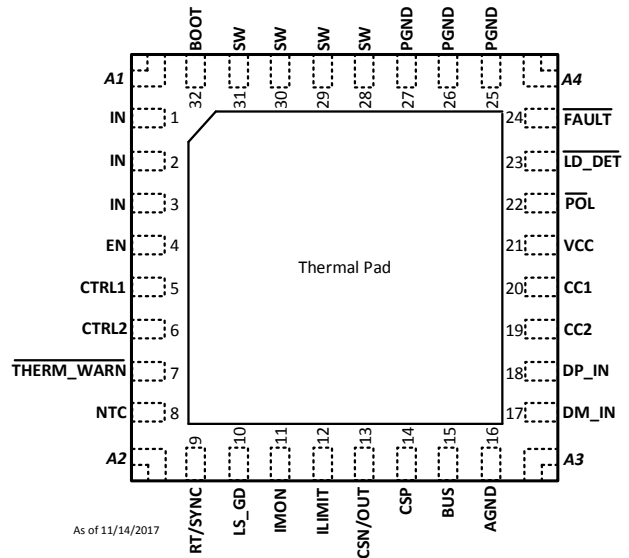

NOTES:

- 1) A1, A2, A3, and A4 are corner anchors for enhanced package stress performance.
- 2) A1, A2, A3, and A4 are electrically connected to the thermal pad.
- 3) A1, A2, A3, and A4 PCB lands should be electrically isolated or electrically connected to thermal pad and PGND.

**图 7-2. TPS25831QWRHBRQ1 Package 32-Pin (VQFN) Top View**

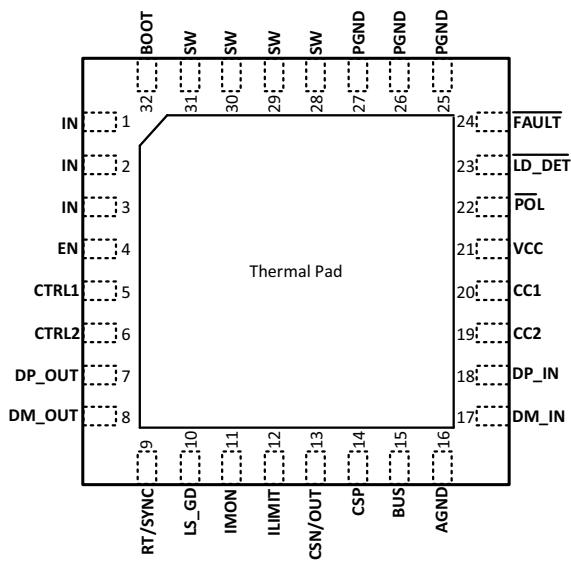

**图 7-3. TPS25830QCWRHBRQ1 Package 32-Pin (VQFN) Top View**

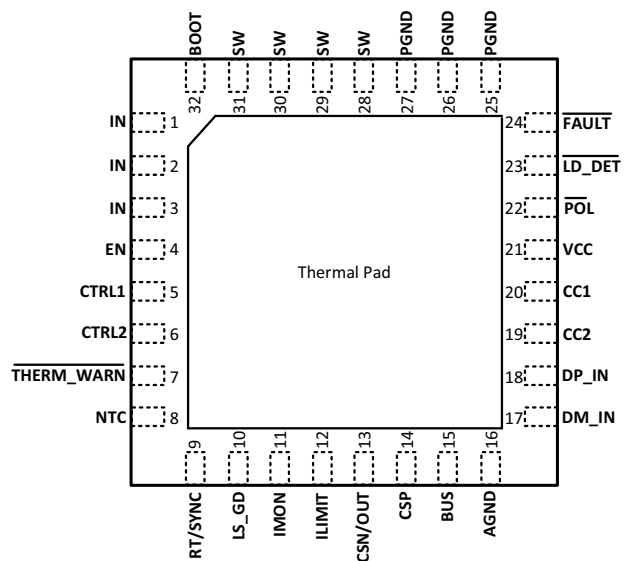

**图 7-4. TPS25831QCWRHBRQ1 Package 32-Pin (VQFN) Top View**

表 7-1. Pin Functions

NAME	830-Q1 NO.	831-Q1 NO.	TYPE (1)	I/O	DESCRIPTION
AGND	16	16	G	-	Analog ground terminal. Ground reference for internal references and logic. All electrical parameters are measured with respect to this pin. Connect to system ground on PCB.
BOOT	32	32	P		Boot-strap capacitor connection for HS FET driver. Connect a high quality 100-nF capacitor from this pin to the SW pin.
BUS	15	15	A	I	VBUS discharge input. Connect to VBUS on USB Connector.
CC1	20	20	A	I/O	Analog input and output. Connect to Type-C CC1 pin.
CC2	19	19	A	I/O	Analog input and output. Connect to Type-C CC2 pin.
CSN/OUT	13	13	A	I	Negative input of current sense amplifier, also buck output for internal voltage regulation.
CSP	14	14	A	I	Positive input of current sense amplifier.
CTRL1	5	5	A	I	Logic-level control inputs for device/system configuration (see <a href="#">Truth Table</a> ).
CTRL2	6	6	A	I	Logic-level control inputs for device/system configuration (see <a href="#">Truth Table</a> ).
DM_IN	17	17	A		DM data line. Connect to USB connector.
DM_OUT	8	-	A		DM data line. Connect to USB host controller.
DP_IN	18	18	A		DP data line. Connect to USB connector.
DP_OUT	7	-	A		DP data line. Connect to USB host controller.
EN/UVLO	4	4	A		Enable pin. Do not float. High = on, Low = off. Can be tied to VIN. Precision enable input allows adjustable UVLO by external resistor divider.
FAULT	24	24	A	O	Active LOW open-drain output. Asserted during fault conditions (see <a href="#">表 10-4</a> ).
ILIMIT	12	12	A		External resistor used to set the current-limit threshold (see <a href="#">表 10-2</a> ).
IMON	11	11	A		External resistor used to set the max cable comp voltage at full load current.
IN	1, 2, 3	1, 2, 3	P	I	Input Supply to regulator. Connect a high-quality bypass capacitor(s) directly to this pin and PGND.
LD_DET	23	23	A	O	Active LOW open-drain output. Asserted when a Type-C UFP is identified on the CC lines.
LS_GD	10	10	A		External NMOS gate driver. For TPS25830-Q1, LS_GD pin must be pulled up through a 2.2-k $\Omega$ resistor under average current limit mode (see <a href="#">Current Limit Setting using R<sub>ILIMIT</sub></a> ).
NTC	-	8		I	Input for negative temperature coefficient resistor divider. Use to monitor external PCB temperature (see <a href="#">Thermal Sensing with NTC (TPS25831-Q1)</a> ).
PGND	25, 26, 27	25, 26, 27	G	-	Power ground terminal. Connect to system ground and AGND. Connect to bypass capacitor with short wide traces.
POL	22	22	A	O	Active LOW open-drain output. Signals which Type-C CC pin is connected to the CC line. This gives cable orientation information needed to mux the super speed lines. Asserted when the CC2 pin is connected to the CC line in the cable.
RT/SYNC	9	9	A		Resistor Timing or External Clock input. An internal amplifier holds this terminal at a fixed voltage when using an external resistor to ground to set the switching frequency. If the terminal is pulled above the PLL upper threshold, a mode change occurs and the terminal becomes a synchronization input. The internal amplifier is disabled and the terminal is a high impedance clock input to the internal PLL. If clocking edges stop, the internal amplifier is re-enabled and the operating mode returns to resistor frequency programming.
SW	28, 29, 30, 31	28, 29, 30, 31	P		Switching output of the regulator. Internally connected to source of the HS FET and drain of the LS FET. Connect to power inductor.

**表 7-1. Pin Functions (continued)**

NAME	830-Q1 NO.	831-Q1 NO.	TYPE (1)	I/O	DESCRIPTION
THERM_WA RN	-	7	A	O	Active LOW open-drain output. Asserted when voltage at the NTC pin increases above the thermal warning threshold.
VCC	21	21	P		Output of internal bias supply. Used as supply to internal control circuits. Connect a high quality 2.2- $\mu$ F capacitor from this pin to GND.

(1) A = Analog, P = Power, G = Ground.

## 8 Specifications

### 8.1 Absolute Maximum Ratings

Voltages are with respect to GND (unless otherwise noted)<sup>(1)</sup>

PARAMETER		MIN	MAX	UNIT
Input voltage	IN to PGND	- 0.3	40	V
	OUT to PGND	- 0.3	20	
	EN to AGND	- 0.3	VIN + 0.3	
	CSP to AGND	- 0.3	20	
	CSN to AGND	- 0.3	20	
	BUS to AGND	- 0.3	18	
	RT/SYNC to AGND	- 0.3	6	
	CTRL1 or CTRL2 to AGND	- 0.3	6	
	AGND to PGND	- 0.3	0.3	
Output voltage	SW to PGND	- 0.3	VIN + 0.3	V
	SW to PGND (less than 10 ns transients)	- 3.5	40	
	BOOT to SW	- 0.3	6	
	VCC to AGND	- 0.3	6	
	LS_GD	- 0.3	18	
Voltage range	CC1 or CC2 to AGND	- 0.3	18	V
	DP_IN, DM_IN to AGND	- 0.3	18	
	DP_OUT, DM_OUT to AGND (TPS25830-Q1 only)	- 0.3	6	
	FAULT, POL, LD_DET to AGND	- 0.3	6	
	THERM_WARN, NTC to AGND (TPS25831-Q1 only)	- 0.3	6	
	ILIMIT or IMON to AGND	- 0.3	6	
Pin positive source current, I <sub>VCC</sub>	VCC Source Current		5	mA
Pin positive source current, I <sub>SRC</sub>	CC1, CC2		Internally Limited	A
Pin positive sink current, I <sub>SNK</sub>	CC1, CC2 (while applying VCONN)		1	A
Pin positive sink current, I <sub>SNK</sub>	FAULT, POL, LD_DET		Internally Limited	A
	THERM_WARN (TPS25831-Q1 only)		Internally Limited	
I/O current	DP_IN to DP_OUT, or DM_IN to DM_OUT in SDP, CDP (TPS25830-Q1 only)	- 100	100	mA
	DP_IN to DM_IN in DCP Auto Mode (TPS25831-Q1 only)	- 35	35	
T <sub>J</sub>	Junction temperature	-40	150	°C
T <sub>stg</sub>	Storage temperature	- 65	150	°C

- (1) Stresses beyond those listed under *Absolute Maximum Rating* may cause permanent damage to the device. These are stress ratings only, which do not imply functional operation of the device at these or any other conditions beyond those indicated under *Recommended Operating Condition*. Exposure to absolute-maximum-rated conditions for extended periods may affect device reliability.

## 8.2 ESD Ratings

			VALUE	UNIT	
V <sub>(ESD)</sub>	Electrostatic discharge	Human body model (HBM), per AEC Q100-002 <sup>(1)</sup>	±2000 <sup>(2)</sup>	V	
		Charged device model (CDM), per AEC Q100-011	Corner pins (1, 8, 9, 17, 25 and 32)		±750 <sup>(3)</sup>
			Other pins		±750 <sup>(3)</sup>
		IEC 61000-4-2 contact discharge	DP_IN, DM_IN, CC1 and CC2 pins		±8000 <sup>(4)</sup>
		IEC 61000-4-2 air-gap discharge	DP_IN, DM_IN, CC1 and CC2 pins		±15000 <sup>(4)</sup>

- (1) AEC Q100-002 indicates that HBM stressing shall be in accordance with the ANSI/ESDA/JEDEC JS-001 specification.  
(2) The passing level per AEC-Q100 Classification H2.  
(3) The passing level per AEC-Q100 Classification C5.  
(4) Surges per IEC61000-4-2, 1999 applied between DP\_IN, DM\_IN, CC1, CC2 and output ground of the TPS2583x-Q1 evaluation module. Addition 0.22u cap is needed on CCx pins.

## 8.3 Recommended Operating Conditions

Voltages are with respect to GND (unless otherwise noted)

			MIN	NOM	MAX	UNIT
V <sub>I</sub>	Input voltage	IN to PGND	4.5		36	V
		EN	0		V <sub>IN</sub>	
		VCC when driven from external regulator	0		5.5	
		DP_IN, DM_IN	0		3.6	
		DP_OUT, DM_OUT (TPS25830-Q1 only)	0		3.6	
		NTC (TPS25831-Q1 only)	0		VCC	
		CTRL1, CTRL2	0		VCC	
		RT/SYNC when driven by external clock	0		VCC	
V <sub>PU</sub>	Pull up voltage	FAULT, LD_DET, POL	0		VCC	V
		THERM_WARN (TPS25831-Q1 only)	0		VCC	
V <sub>O</sub>	Output voltage	CSN/OUT	0		6.5	V
I <sub>O</sub>	Output current	Buck regulator output current	0		3.5	A
		DP_IN to DP_OUT or DM_IN to DM_OUT Continuous current in SDP, CDP	- 30		30	mA
		DP_IN to DM_IN Continuous current in BC1.2 DCP Mode	- 15		15	
I <sub>SRC</sub>	Source current	CC1 or CC2 source current when supplying VCONN			250	
I <sub>SNK</sub>	Sink current	FAULT, LD_DET, POL			10	
		THERM_WARN (TPS25831-Q1 only)			10	
I <sub>I</sub>	Input current	Continuous current into the CSP pin			200	μA
R <sub>EXT</sub>	External resistnace	R <sub>IMON</sub> , R <sub>LIMIT</sub>	0		100	k Ω
T <sub>J</sub>	Operating junction temperature		- 40		125 <sup>(1)</sup>	°C

- (1) Operating at junction temperatures greater than 125°C is possible, however lifetime will be degraded.

## 8.4 Thermal Information

THERMAL METRIC <sup>(1)</sup>		TPS2583x-Q1	UNIT
		RHB (VQFN)	
		32 PINS	
$R_{\theta JA}$	Junction-to-ambient thermal resistance	28.7	°C/W
$R_{\theta JC(top)}$	Junction-to-case (top) thermal resistance	17.6	°C/W
$R_{\theta JB}$	Junction-to-board thermal resistance	7.2	°C/W
$\Psi_{JT}$	Junction-to-top characterization parameter	0.2	°C/W
$\Psi_{JB}$	Junction-to-board characterization parameter	7.2	°C/W
$R_{\theta JC(bot)}$	Junction-to-case (bottom) thermal resistance	1	°C/W

(1) For more information about traditional and new thermal metrics, see the [Semiconductor and IC Package Thermal Metrics](#) application report.

## 8.5 Electrical Characteristics

Limits apply over the junction temperature ( $T_J$ ) range of  $-40^{\circ}\text{C}$  to  $+150^{\circ}\text{C}$ ;  $V_{IN} = 13.5\text{ V}$ ,  $f_{SW} = 400\text{ kHz}$ ,  $C_{VCC} = 2.2\ \mu\text{F}$ ,  $R_{SNS} = 15\text{ m}\Omega$ ,  $R_{IMON} = 13\text{ k}\Omega$ ,  $R_{LIMIT} = 13\text{ k}\Omega$ ,  $R_{SET} = 300\ \Omega$  unless otherwise stated. Minimum and maximum limits are specified through test, design or statistical correlation. Typical values represent the most likely parametric norm at  $T_J = 25^{\circ}\text{C}$ , and are provided for reference purposes only.

PARAMETER		TEST CONDITIONS	MIN	TYP	MAX	UNIT
<b>SUPPLY VOLTAGE (IN PIN)</b>						
$V_{IN}$	Operating input voltage range		4.5		36	V
$I_Q$	Operating quiescent current (non switching)	$V_{EN/UVLO} = V_{IN}$ , CTRL1 = CTRL2 = $V_{CC}$ , $V_{CSN} = 8\text{ V}$ , CC1 or CC2 = $R_D$ , CC2 or CC1 = open		700	990	$\mu\text{A}$
$I_{Q-SB}$	Standby quiescent current	$V_{EN/UVLO} = V_{IN}$ , CTRL1 = CTRL2 = $V_{CC}$ , CC1 and CC2 = open			290	$\mu\text{A}$
$I_{SD}$	Shutdown quiescent current; measured at IN pin.	EN = 0		10	16	$\mu\text{A}$
<b>ENABLE and UVLO (EN/UVLO PIN)</b>						
$V_{EN/UVLO\_VCC\_H}$	EN/UVLO input level required to turn on internal LDO	$V_{EN/UVLO}$ rising threshold			1.14	V
$V_{EN/UVLO\_VCC\_L}$	EN/UVLO input level required to turn off internal LDO	$V_{EN/UVLO}$ falling threshold	0.3			V
$V_{EN/UVLO\_H}$	EN/UVLO input level required to turn on state machine	$V_{EN/UVLO}$ rising threshold	1.140	1.200	1.260	V
$V_{EN/UVLO\_HYS}$	Hysteresis	$V_{EN/UVLO}$ falling threshold		90		mV
$I_{LKG\_EN/UVLO}$	Enable input leakage current	$V_{EN/UVLO} = 3.3\text{ V}$		0.5		$\mu\text{A}$
<b>INTERNAL LDO</b>						
$V_{BOOT\_UVLO}$	Bootstrap voltage UVLO threshold			2.2		V
$V_{CC}$	Internal LDO output voltage appearing on VCC pin	$6\text{ V} \leq V_{IN} \leq 36\text{ V}$	4.75	5	5.25	V
$V_{CC\_UVLO\_R}$	Rising UVLO threshold		3.4	3.6	3.8	V
$V_{CC\_UVLO\_HYS}$	Hysteresis			600		mV
<b>CURRENT LIMIT VOLTAGE (CSP - CSN/OUT PINS) TO ACTIVATE BUCK AVG CURRENT LIMITING</b>						
$(V_{CSP} - V_{CSN/OUT})$	Current limit voltage buck regulator control loop	$V_{CSN} = 5\text{ V}$ , $R_{SET} = 300\ \Omega$ , $R_{LIMIT} = 13\text{ k}\Omega$ , $R_{IMON} = 13\text{ k}\Omega$ , $-40^{\circ}\text{C} \leq T_J \leq 125^{\circ}\text{C}$	43.5	46	48.5	mV
$(V_{CSP} - V_{CSN/OUT})$	Current limit voltage buck regulator control loop	$V_{CSN} = 5\text{ V}$ , $R_{SET} = 300\ \Omega$ , $R_{LIMIT} = 13\text{ k}\Omega$ , $R_{IMON} = 13\text{ k}\Omega$ , $-40^{\circ}\text{C} \leq T_J \leq 150^{\circ}\text{C}$	42.5	46	49.5	mV

## 8.5 Electrical Characteristics (continued)

Limits apply over the junction temperature ( $T_J$ ) range of  $-40^{\circ}\text{C}$  to  $+150^{\circ}\text{C}$ ;  $V_{IN} = 13.5\text{ V}$ ,  $f_{SW} = 400\text{ kHz}$ ,  $C_{VCC} = 2.2\text{ }\mu\text{F}$ ,  $R_{SNS} = 15\text{ m}\Omega$ ,  $R_{IMON} = 13\text{ k}\Omega$ ,  $R_{ILIMIT} = 13\text{ k}\Omega$ ,  $R_{SET} = 300\text{ }\Omega$  unless otherwise stated. Minimum and maximum limits are specified through test, design or statistical correlation. Typical values represent the most likely parametric norm at  $T_J = 25^{\circ}\text{C}$ , and are provided for reference purposes only.

PARAMETER		TEST CONDITIONS	MIN	TYP	MAX	UNIT
$(V_{CSP} - V_{CSN}/\text{OUT})$	Current limit voltage buck regulator control loop	$V_{CSN} = 5\text{ V}$ , $R_{SET} = 300\text{ }\Omega$ , $R_{ILIMIT} = 26.1\text{ k}\Omega$ , $R_{IMON} = 13\text{ k}\Omega$ , $-40^{\circ}\text{C} \leq T_J \leq 125^{\circ}\text{C}$	20	22.5	25	mV
$(V_{CSP} - V_{CSN}/\text{OUT})$	Current limit voltage buck regulator control loop	$V_{CSN} = 5\text{ V}$ , $R_{SET} = 300\text{ }\Omega$ , $R_{ILIMIT} = 26.1\text{ k}\Omega$ , $R_{IMON} = 13\text{ k}\Omega$ , $-40^{\circ}\text{C} \leq T_J \leq 150^{\circ}\text{C}$	19	22.5	26	mV
<b>CURRENT LIMIT VOLTAGE (CSP - CSN/OUT PINS) TO ACTIVATE EXTERNAL NFET CURRENT LIMITING</b>						
$(V_{CSP} - V_{CSN}/\text{OUT})$	Current limit voltage NFET control loop	$V_{CSN} = 5\text{ V}$ , $R_{SET} = 300\text{ }\Omega$ , $R_{ILIMIT} = 6.8\text{ k}\Omega$ , $R_{IMON} = 13\text{ k}\Omega$ , $-40^{\circ}\text{C} \leq T_J \leq 125^{\circ}\text{C}$	40	43	46	mV
$(V_{CSP} - V_{CSN}/\text{OUT})$	Current limit voltage NFET control loop	$V_{CSN} = 5\text{ V}$ , $R_{SET} = 300\text{ }\Omega$ , $R_{ILIMIT} = 6.8\text{ k}\Omega$ , $R_{IMON} = 13\text{ k}\Omega$ , $-40^{\circ}\text{C} \leq T_J \leq 150^{\circ}\text{C}$	38.5	43	47.5	mV
$(V_{CSP} - V_{CSN}/\text{OUT})$	Current limit voltage NFET control loop	$V_{CSN} = 5\text{ V}$ , $R_{SET} = 300\text{ }\Omega$ , $R_{ILIMIT} = 13.7\text{ k}\Omega$ , $R_{IMON} = 13\text{ k}\Omega$ , $-40^{\circ}\text{C} \leq T_J \leq 125^{\circ}\text{C}$	18	21	24	mV
$(V_{CSP} - V_{CSN}/\text{OUT})$	Current limit voltage NFET control loop	$V_{CSN} = 5\text{ V}$ , $R_{SET} = 300\text{ }\Omega$ , $R_{ILIMIT} = 13.7\text{ k}\Omega$ , $R_{IMON} = 13\text{ k}\Omega$ , $-40^{\circ}\text{C} \leq T_J \leq 150^{\circ}\text{C}$	17	21	25	mV
<b>CURRENT LIMIT - BUCK REGULATOR PEAK CURRENT LIMIT</b>						
$I_{L-SC-HS}$	High-side current limit		4.6	5.4	6.2	A
$I_{L-SC-LS}$	Low-side current limit		3.5	4	4.5	A
$I_{L-NEG-LS}$	Low-side negative current limit		-3.1	-2.1	-1.3	A
<b>CABLE COMPENSATION VOLTAGE</b>						
$V_{IMON}$	Cable compensation voltage	$(V_{CSP} - V_{CSN}) = 46\text{ mV}$ , $R_{SET} = 300\text{ }\Omega$ , $R_{ILIMIT} = 13\text{ k}\Omega$ , $R_{IMON} = 13\text{ k}\Omega$	0.935	1	1.065	V
$V_{IMON}$	Cable compensation voltage	$(V_{CSP} - V_{CSN}) = 23\text{ mV}$ , $R_{SET} = 300\text{ }\Omega$ , $R_{ILIMIT} = 13\text{ k}\Omega$ , $R_{IMON} = 13\text{ k}\Omega$	0.435	0.5	0.565	V
$V_{IMON}$	Cable compensation voltage (internal clamp)	$(V_{CSP} - V_{CSN}) = 46\text{ mV}$ , $R_{SET} = 300\text{ }\Omega$ , $R_{ILIMIT} = 13\text{ k}\Omega$ , $R_{IMON} = \text{open}$		1.8		V
<b>BUCK OUTPUT VOLTAGE (CSN/OUT PIN)</b>						
$V_{CSN/OUT}$	Output voltage	CC1 or CC2 pulldown resistance = $R_d$ , $R_{IMON} = 0\text{ }\Omega$ , $R_{ILIMIT} = 0\text{ }\Omega$	5.05	5.10	5.15	V
$V_{CSN/OUT}$	Output voltage accuracy	CC1 or CC2 pulldown resistance = $R_d$ , $R_{IMON} = 0\text{ }\Omega$ , $R_{ILIMIT} = 0\text{ }\Omega$	-1		1	%
$V_{CSN/OUT\_OV}$	Overvoltage level on CSN/OUT pin which buck regulator stops switching	$V_{CSN/OUT}$ rising	7.1	7.5	7.9	V
$V_{CSN/OUT\_OV\_HYS}$	Hysteresis			500		mV
$V_{HC}$	CSN / OUT pin voltage required to trigger short circuit hiccup mode			2		V
$V_{DROP}$	Dropout voltage ( $V_{IN} - V_{OUT}$ )	$V_{IN} = V_{OUT} + V_{DROP}$ , $V_{OUT} = 5.1\text{ V}$ , $I_{OUT} = 3\text{ A}$		150		mV
<b>BUCK REGULATOR INTERNAL RESISTANCE</b>						
$R_{DS-ON-HS}$	High-side MOSFET ON-resistance	Load = 3 A, $T_J = 25^{\circ}\text{C}$		40	45	$\text{m}\Omega$
$R_{DS-ON-HS}$	High-side MOSFET ON-resistance	Load = 3 A, $-40^{\circ}\text{C} \leq T_J \leq 125^{\circ}\text{C}$		40	68	$\text{m}\Omega$
$R_{DS-ON-HS}$	High-side MOSFET ON-resistance	Load = 3 A, $-40^{\circ}\text{C} \leq T_J \leq 150^{\circ}\text{C}$		40	75	$\text{m}\Omega$

## 8.5 Electrical Characteristics (continued)

Limits apply over the junction temperature ( $T_J$ ) range of  $-40^{\circ}\text{C}$  to  $+150^{\circ}\text{C}$ ;  $V_{IN} = 13.5\text{ V}$ ,  $f_{SW} = 400\text{ kHz}$ ,  $C_{VCC} = 2.2\text{ }\mu\text{F}$ ,  $R_{SNS} = 15\text{ m}\Omega$ ,  $R_{IMON} = 13\text{ k}\Omega$ ,  $R_{LIMIT} = 13\text{ k}\Omega$ ,  $R_{SET} = 300\text{ }\Omega$  unless otherwise stated. Minimum and maximum limits are specified through test, design or statistical correlation. Typical values represent the most likely parametric norm at  $T_J = 25^{\circ}\text{C}$ , and are provided for reference purposes only.

PARAMETER		TEST CONDITIONS	MIN	TYP	MAX	UNIT
$R_{DS-ON-LS}$	Low-side MOSFET ON-resistance	Load = 3 A, $T_J = 25^{\circ}\text{C}$		35	41	$\text{m}\Omega$
$R_{DS-ON-LS}$	Low-side MOSFET ON-resistance	Load = 3 A, $-40^{\circ}\text{C} \leq T_J \leq 125^{\circ}\text{C}$		35	60	$\text{m}\Omega$
$R_{DS-ON-LS}$	Low-side MOSFET ON-resistance	Load = 3 A, $-40^{\circ}\text{C} \leq T_J \leq 150^{\circ}\text{C}$		35	68	$\text{m}\Omega$
<b>NFET GATE DRIVE (LS_GD PIN)</b>						
$V_{LS\_GD}$	NFET gate drive output voltage	$V_{CSN/OUT} = 5.1\text{ V}$ , $C_G = 1000\text{ pF}$ (see 图 9-4)	9.5	11	12.5	V
$I_{LS\_DR\_SRC}$	NFET gate drive output source current	$V_{CSN/OUT} = 5.1\text{ V}$ , $C_G = 1000\text{ pF}$	2	3	4	$\mu\text{A}$
$I_{LS\_DR\_SNK}$	NFET gate drive output sink current	$V_{CSN/OUT} = 5.1\text{ V}$ , $C_G = 1000\text{ pF}$	20	35	50	$\mu\text{A}$
$V_{LS\_GD\_UVLO\_R}$	$V_{CSN/OUT}$ rising threshold for LS_GD operation	$V_{CSN/OUT}$ rising	2.85	3	3.15	V
$V_{LS\_GD\_UVLO\_HYS}$	Hysteresis			80		mV
<b>BUS DISCHARGE (BUS PIN)</b>						
$R_{BUS\_DCHG}$	BUS discharge resistance	$V_{BUS} = 4\text{ V}$	250	320	550	$\Omega$
$V_{BUS\_NO\_DCHG}$	Falling threshold for VBUS not discharged				0.8	V
$R_{BUS\_DCHG\_BLEED}$	BUS bleed resistance	$V_{BUS} = 4\text{ V}$ , No sink termination on CC lines, Time > $t_{W\_BUS\_DCHG}$	100	130	200	$\text{k}\Omega$
$V_{BUS\_OV}$	Rising threshold for BUS pin overvoltage protection	$V_{BUS}$ rising	6.6	7	7.3	V
$V_{BUS\_OV\_HYS}$	Hysteresis			180		mV
$R_{BUS\_DCHG\_18V}$	Discharge resistance for BUS	$V_{BUS} = 18\text{ V}$ , measure leakage current		29		$\text{k}\Omega$
$R_{BUS\_DCHG\_8V}$	Discharge resistance for BUS	$V_{BUS} = 8\text{ V}$ , measure leakage current		35		$\text{k}\Omega$
<b>CC1 AND CC2 - VCONN POWER SWITCH (CC1 AND CC2 PINS)</b>						
$R_{DS-ON}$	On-state resistance	$I_{CCn} = 250\text{ mA}$ , $T_J = 25^{\circ}\text{C}$		500	540	$\text{m}\Omega$
$R_{DS-ON}$	On-state resistance	$I_{CCn} = 250\text{ mA}$ , $-40^{\circ}\text{C} \leq T_J \leq 125^{\circ}\text{C}$ ,		500	830	$\text{m}\Omega$
$R_{DS-ON}$	On-state resistance	$I_{CCn} = 250\text{ mA}$ , $-40^{\circ}\text{C} \leq T_J \leq 150^{\circ}\text{C}$ ,		500	920	$\text{m}\Omega$
$I_{OS\_CCn}$	VCONN short circuit current limit	Short circuit current limit	350	430	550	mA
$R_{VCONN\_DCHG}$	Discharge resistance	CC pin that was providing $V_{VCONN}$ before detach: $V_{CCX} = 4\text{ V}$	650	850	1100	$\Omega$
$V_{TH}$	Falling threshold for discharged	CC pin that was providing $V_{VCONN}$ before detach	570	600	630	mV
$V_{TH}$	Discharged threshold hysteresis			100		mV
$V_{CCx\_OV}$	Rising threshold for CCn pin overvoltage protection	CC pin voltage $V_{CCn}$ rising	5.8	6.1	6.4	V
$V_{CCx\_OV\_HYS}$	Hysteresis			150		mV
$R_{CCn\_DCHG\_18V}$	Discharge resistance for CCn	CC pin voltage $V_{CCn} = 18\text{ V}$ , measure leakage current		40		$\text{k}\Omega$
$R_{CCn\_DCHG\_8V}$	Discharge resistance for CCn	CC pin voltage $V_{CCn} = 8\text{ V}$ , measure leakage current		86		$\text{k}\Omega$
<b>CC1/CC2 CONNECT MANAGEMENT: DANGLING ELECTRONICALLY MARKED CABLE MODE</b>						
$I_{SRC\_CCn}$	Sourcing current on the passthrough CC line	CC pin voltage $0\text{ V} \leq V_{CCn} \leq 1.5\text{ V}$	64	80	96	$\mu\text{A}$
$I_{SRC\_CCn}$	Sourcing current on the Ra CC line	CC pin voltage $0\text{ V} \leq V_{CCn} \leq 1.5\text{ V}$	64	80	96	$\mu\text{A}$

## 8.5 Electrical Characteristics (continued)

Limits apply over the junction temperature ( $T_J$ ) range of  $-40^{\circ}\text{C}$  to  $+150^{\circ}\text{C}$ ;  $V_{IN} = 13.5\text{ V}$ ,  $f_{SW} = 400\text{ kHz}$ ,  $C_{VCC} = 2.2\text{ }\mu\text{F}$ ,  $R_{SNS} = 15\text{ m}\Omega$ ,  $R_{IMON} = 13\text{ k}\Omega$ ,  $R_{LIMIT} = 13\text{ k}\Omega$ ,  $R_{SET} = 300\text{ }\Omega$  unless otherwise stated. Minimum and maximum limits are specified through test, design or statistical correlation. Typical values represent the most likely parametric norm at  $T_J = 25^{\circ}\text{C}$ , and are provided for reference purposes only.

PARAMETER		TEST CONDITIONS	MIN	TYP	MAX	UNIT
<b>CC1/CC2 CONNECT MANAGEMENT: UFP MODE (TPS25830-Q1)</b>						
$I_{SRC\_CCn}$	Sourcing current	$V_{CTRL1} = V_{CC}$ and $V_{CTRL2} = V_{CC}$ , CC pin voltage: $0\text{ V} \leq V_{CCn} \leq 1.5\text{ V}$ (with CDP mode)	308	330	354	$\mu\text{A}$
$I_{SRC\_CCn}$	Sourcing current	$V_{CTRL1} = V_{CC}$ and $V_{CTRL2} = \text{GND}$ , CC pin voltage: $0\text{ V} \leq V_{CCn} \leq 1.5\text{ V}$ (with SDP mode)	168	180	192	$\mu\text{A}$
<b>CC1/CC2 CONNECT MANAGEMENT: UFP MODE (TPS25831-Q1)</b>						
$I_{SRC\_CCn}$	Sourcing current	$V_{CTRL1} = V_{CC}$ and $V_{CTRL2} = V_{CC}$ , CC pin voltage: $0\text{ V} \leq V_{CCn} \leq 1.5\text{ V}$ (with CDP mode)	308	330	354	$\mu\text{A}$
$I_{SRC\_CCn}$	Sourcing current	$V_{CTRL1} = V_{CC}$ and $V_{CTRL2} = \text{GND}$ , CC pin voltage: $0\text{ V} \leq V_{CCn} \leq 1.5\text{ V}$ (with SDP mode)	168	180	192	$\mu\text{A}$
$I_{SRC\_CCn}$	Sourcing current	$V_{CTRL1} = \text{GND}$ and $V_{CTRL2} = V_{CC}$ , CC pin voltage: $0\text{ V} \leq V_{CCn} \leq 1.5\text{ V}$ (with DCP auto mode)	308	330	354	$\mu\text{A}$
$I_{REV}$	Reverse leakage current	CCx is the CC pin under test, CCy is the other CC pin. CC pin voltage $V_{CCx} = 5.5\text{ V}$ , $CCy = 0\text{V}$ or floating, $V_{EN} = 0\text{ V}$ , $I_{REV}$ is current into CCx pin		0	5	$\mu\text{A}$
$I_{REV}$	Reverse leakage current	CCx is the CC pin under test, CCy is the other CC pin. CC pin voltage $V_{CCx} = 5.5\text{ V}$ , $CCy = 0$ , $V_{EN} = V_{IN}$ , $I_{REV}$ is current into CCx pin under test		6	10	$\mu\text{A}$
<b>FAULT, LD_DET, POL</b>						
$V_{OL}$	FAULT Output low voltage	$I_{SNK\_PIN} = 0.5\text{ mA}$			250	mV
$I_{OFF}$	FAULT Off-state leakage	$V_{PIN} = 5.5\text{ V}$			1	$\mu\text{A}$
$V_{OL}$	LD_DET, POL Output low voltage	$I_{SNK\_PIN} = 0.5\text{ mA}$			250	mV
$I_{OFF}$	LD_DET, POL Off-state leakage	$V_{PIN} = 5.5\text{ V}$			1	$\mu\text{A}$
<b>THERM_WARN (TPS25831-Q1)</b>						
$V_{OL}$	THERM_WARN Output low voltage	$I_{SNK\_PIN} = 0.5\text{ mA}$			250	mV
$I_{OFF}$	THERM_WARN Off-state leakage	$V_{PIN} = 5.5\text{ V}$			1	$\mu\text{A}$
<b>CTRL1, CTRL2 - LOGIC INPUTS</b>						
$V_{IH}$	Rising threshold voltage			1.48	2	V
$V_{IL}$	Falling threshold voltage		0.85	1.30		V
$V_{HYS}$	Hysteresis			180		mV
$I_{IN}$	Input current		-1		1	$\mu\text{A}$
<b>DP_IN AND DM_IN OVERVOLTAGE PROTECTION</b>						
$V_{Dx\_IN\_OV}$	Rising threshold for Dx_IN overvoltage protection	DP_IN or DM_IN rising	3.7	3.9	4.15	V
	Hysteresis			100		mV
$R_{Dx\_IN\_DCHG\_18V}$	Discharge resistance for Dx_IN	$V_{Dx\_IN} = 18\text{V}$ , measure leakage current		94		$\text{k}\Omega$
$R_{Dx\_IN\_DCHG\_5V}$	Discharge resistance for Dx_IN	$V_{Dx\_IN} = 5\text{V}$ , measure leakage current		416		$\text{k}\Omega$
<b>HIGH-BANDWIDTH ANALOG SWITCH (TPS25830-Q1)</b>						

## 8.5 Electrical Characteristics (continued)

Limits apply over the junction temperature ( $T_J$ ) range of  $-40^{\circ}\text{C}$  to  $+150^{\circ}\text{C}$ ;  $V_{IN} = 13.5\text{ V}$ ,  $f_{SW} = 400\text{ kHz}$ ,  $C_{VCC} = 2.2\text{ }\mu\text{F}$ ,  $R_{SNS} = 15\text{ m}\Omega$ ,  $R_{IMON} = 13\text{ k}\Omega$ ,  $R_{LIMIT} = 13\text{ k}\Omega$ ,  $R_{SET} = 300\text{ }\Omega$  unless otherwise stated. Minimum and maximum limits are specified through test, design or statistical correlation. Typical values represent the most likely parametric norm at  $T_J = 25^{\circ}\text{C}$ , and are provided for reference purposes only.

PARAMETER		TEST CONDITIONS	MIN	TYP	MAX	UNIT
$R_{DS\_ON}$	DP and DM switch on-resistance	$V_{DP\_OUT} = V_{DM\_OUT} = 0\text{ V}$ , $I_{DP\_IN} = I_{DM\_IN} = 30\text{ mA}$		3.4	6.3	$\Omega$
$R_{DS\_ON}$	DP and DM switch on-resistance	$V_{DP\_OUT} = V_{DM\_OUT} = 2.4\text{ V}$ , $I_{DP\_IN} = I_{DM\_IN} = -15\text{ mA}$		4.3	7.7	$\Omega$
$ \Delta R_{DS\_ON} $	Switch resistance mismatch between DP and DM channels	$V_{DP\_OUT} = V_{DM\_OUT} = 0\text{ V}$ , $I_{DP\_IN} = I_{DM\_IN} = 30\text{ mA}$		0.05	0.15	$\Omega$
$ \Delta R_{DS\_ON} $	Switch resistance mismatch between DP and DM channels	$V_{DP\_OUT} = V_{DM\_OUT} = 2.4\text{ V}$ , $I_{DP\_IN} = I_{DM\_IN} = -15\text{ mA}$		0.05	0.15	$\Omega$
$C_{IO\_OFF}$	DP/DM switch off-state capacitance	$V_{EN} = 0\text{ V}$ , $V_{DP\_IN} = V_{DM\_IN} = 0.3\text{ V}$ , $V_{ac} = 0.03\text{ V}_{PP}$ , $f = 1\text{ MHz}$		6.7		pF
$C_{IO\_ON}$	DP/DM switch on-state capacitance	$V_{DP\_IN} = V_{DM\_IN} = 0.3\text{ V}$ , $V_{ac} = 0.03\text{ V}_{PP}$ , $f = 1\text{ MHz}$		10		pF
$O_{IRR}$	Off-state isolation	$V_{EN} = 0\text{ V}$ , $f = 250\text{ MHz}$		9		dB
$X_{TALK}$	On-state cross-channel isolation	$f = 250\text{ MHz}$		29		dB
$I_{lkg(OFF)}$	Off-state leakage current, DP_OUT and DM_OUT	$V_{EN} = 0\text{ V}$ , $V_{DP\_IN} = V_{DM\_IN} = 3.6\text{ V}$ , $V_{DP\_OUT} = V_{DM\_OUT} = 0\text{ V}$ , measure $I_{DP\_OUT}$ and $I_{DM\_OUT}$		0.1	1.5	$\mu\text{A}$
BW	Bandwidth ( - 3 dB)	$R_L = 50\text{ }\Omega$		800		MHz
<b>CHARGING DOWNSTREAM PORT (CDP) DETECT</b>						
$V_{DM\_SRC}$	DM_IN CDP output voltage	$V_{DP\_IN} = 0.6\text{ V}$ , $-250\text{ }\mu\text{A} < I_{DM\_IN} < 0\text{ }\mu\text{A}$	0.5	0.6	0.7	V
$V_{DAT\_REF}$	DP_IN rising lower window threshold for $V_{DM\_SRC}$ activation		0.36	0.38	0.4	V
$V_{DAT\_REF}$	Hysteresis			50		mV
$V_{LGC\_SRC}$	DP_IN rising upper window threshold for $V_{DM\_SRC}$ deactivation		0.8	0.84	0.88	V
$V_{LGC\_SRC\_HYS}$	Hysteresis			100		mV
$I_{DP\_SINK}$	DP_IN sink current	$V_{DP\_IN} = 0.6\text{ V}$	40	70	100	$\mu\text{A}$
<b>BC 1.2 DOWNSTREAM CHARGING PORT (TPS25831-Q1)</b>						
$R_{DPM\_SHORT}$	DP_IN and DM_IN shorting resistance			135	200	$\Omega$
<b>DIVIDER3 MODE (TPS25831-Q1)</b>						
$V_{DP\_DIV3}$	DP_IN output voltage		2.57	2.7	2.84	V
$V_{DM\_DIV3}$	DM_IN output voltage		2.57	2.7	2.84	V
$R_{DP\_DIV3}$	DP_IN output impedance	$I_{DP\_IN} = -5\text{ }\mu\text{A}$	24	30	36	k $\Omega$
$R_{DM\_DIV3}$	DM_IN output impedance	$I_{DM\_IN} = -5\text{ }\mu\text{A}$	24	30	36	k $\Omega$
<b>1.2-V MODE (TPS25831-Q1)</b>						
$V_{DP\_1.2V}$	DP_IN output voltage		1.12	1.2	1.26	V
$V_{DM\_1.2V}$	DM_IN output voltage		1.12	1.2	1.26	V
$R_{DP\_1.2V}$	DP_IN output impedance	$I_{DP\_IN} = -5\text{ }\mu\text{A}$	84	100	126	k $\Omega$
$R_{DM\_1.2V}$	DM_IN output impedance	$I_{DM\_IN} = -5\text{ }\mu\text{A}$	84	100	126	k $\Omega$
<b>RT/SYNC THRESHOLD (RT/SYNC PIN)</b>						
$V_{IH\_RT/SYNC}$	RT/SYNC high threshold for external clock synchronization	Amplitude of SYNC clock AC signal (measured at SYNC pin)	3.5			V
$V_{IL\_RT/SYNC}$	RT/SYNC low threshold for external clock synchronization	Amplitude of SYNC clock AC signal (measured at SYNC pin)			0.8	V

## 8.5 Electrical Characteristics (continued)

Limits apply over the junction temperature ( $T_J$ ) range of  $-40^{\circ}\text{C}$  to  $+150^{\circ}\text{C}$ ;  $V_{IN} = 13.5\text{ V}$ ,  $f_{SW} = 400\text{ kHz}$ ,  $C_{VCC} = 2.2\text{ }\mu\text{F}$ ,  $R_{SNS} = 15\text{ m}\Omega$ ,  $R_{IMON} = 13\text{ k}\Omega$ ,  $R_{ILIMIT} = 13\text{ k}\Omega$ ,  $R_{SET} = 300\text{ }\Omega$  unless otherwise stated. Minimum and maximum limits are specified through test, design or statistical correlation. Typical values represent the most likely parametric norm at  $T_J = 25^{\circ}\text{C}$ , and are provided for reference purposes only.

PARAMETER		TEST CONDITIONS	MIN	TYP	MAX	UNIT
<b>NTC TEMPERATURE SENSING (TPS25831-Q1)</b>						
$V_{WARN\_HIGH}$	Temperature warning threshold rising		$V_{CC} \times 0.475$	$V_{CC} \times 0.5$	$V_{CC} \times 0.525$	V
$V_{WARN\_HYS}$	Hysteresis			$V_{CC} \times 0.1$		V
$V_{SD\_HIGH}$	Temperature shutdown threshold rising		$V_{CC} \times 0.618$	$V_{CC} \times 0.65$	$V_{CC} \times 0.683$	V
$V_{SD\_HYS}$	Hysteresis			$V_{CC} \times 0.1$		V
<b>THERMAL SHUTDOWN</b>						
$T_{SD}$	Thermal shutdown	Shutdown threshold		160		$^{\circ}\text{C}$
		Recovery threshold		140		$^{\circ}\text{C}$

## 8.6 Timing Requirements

Limits apply over the junction temperature ( $T_J$ ) range of  $-40^{\circ}\text{C}$  to  $+150^{\circ}\text{C}$ ;  $V_{IN} = 13.5\text{ V}$ ,  $f_{SW} = 400\text{ kHz}$ ,  $C_{VCC} = 2.2\text{ }\mu\text{F}$ ,  $R_{SNS} = 15\text{ m}\Omega$ ,  $R_{IMON} = 13\text{ k}\Omega$ ,  $R_{ILIMIT} = 13\text{ k}\Omega$ ,  $R_{SET} = 300\text{ }\Omega$  unless otherwise stated. Minimum and maximum limits are specified through test, design or statistical correlation. Typical values represent the most likely parametric norm at  $T_J = 25^{\circ}\text{C}$ , and are provided for reference purposes only.

		MIN	NOM	MAX	UNIT
<b>SYNC (RT/SYNC PIN) WITH EXTERNAL CLOCK</b>					
$f_{SYNC}$	Switching frequency using external clock on RT/SYNC pin	300		2300	kHz
$T_{SYNC\_MIN}$	Minimum SYNC input pulse width	$f_{SYNC} = 400\text{ kHz}$ , $V_{RT/SYNC} > V_{IH\_RT/SYNC}$ , $V_{RT/SYNC} < V_{IL\_RT/SYNC}$		100	ns
$T_{LOCK\_IN}$	PLL lock time		100		$\mu\text{s}$

## 8.7 Switching Characteristics

Limits apply over the junction temperature ( $T_J$ ) range of  $-40^{\circ}\text{C}$  to  $+150^{\circ}\text{C}$ ;  $V_{IN} = 13.5\text{ V}$ ,  $f_{SW} = 400\text{ kHz}$ ,  $C_{VCC} = 2.2\text{ }\mu\text{F}$ ,  $R_{SNS} = 15\text{ m}\Omega$ ,  $R_{IMON} = 13\text{ k}\Omega$ ,  $R_{ILIMIT} = 13\text{ k}\Omega$ ,  $R_{SET} = 300\text{ }\Omega$  unless otherwise stated. Minimum and maximum limits are specified through test, design or statistical correlation. Typical values represent the most likely parametric norm at  $T_J = 25^{\circ}\text{C}$ , and are provided for reference purposes only.

PARAMETER		TEST CONDITIONS	MIN	TYP	MAX	UNIT
<b>SOFT START</b>						
$T_{SS}$	Internal soft-start time	The time of internal reference to increase from 0 V to 1.0 V	3	5	7	ms
<b>HICCUP MODE</b>						
$N_{OC}$	Number of cycles that LS current limit is tripped to enter Hiccup mode			128		Cycles
$T_{OC}$	Hiccup retry delay time			118		ms
<b>SW (SW PIN)</b>						
$T_{ON\_MIN}$	Minimum turnon-time			105		ns
$T_{ON\_MAX}$	Maximum turnon-time, HS timeout in dropout			7.5		$\mu\text{s}$
$T_{OFF\_MIN}$	Minimum turnoff time			80		ns
$D_{max}$	Maximum switch duty cycle			98		%
<b>TIMING RESISTOR AND INTERNAL CLOCK</b>						

## 8.7 Switching Characteristics (continued)

Limits apply over the junction temperature ( $T_J$ ) range of  $-40^{\circ}\text{C}$  to  $+150^{\circ}\text{C}$ ;  $V_{IN} = 13.5\text{ V}$ ,  $f_{SW} = 400\text{ kHz}$ ,  $C_{VCC} = 2.2\text{ }\mu\text{F}$ ,  $R_{SNS} = 15\text{ m}\Omega$ ,  $R_{IMON} = 13\text{ k}\Omega$ ,  $R_{LIMIT} = 13\text{ k}\Omega$ ,  $R_{SET} = 300\text{ }\Omega$  unless otherwise stated. Minimum and maximum limits are specified through test, design or statistical correlation. Typical values represent the most likely parametric norm at  $T_J = 25^{\circ}\text{C}$ , and are provided for reference purposes only.

PARAMETER		TEST CONDITIONS	MIN	TYP	MAX	UNIT
$f_{SW\_RANGE}$	Switching frequency range using RT mode		300		2300	kHz
$f_{SW}$	Switching frequency	$R_T = 49.9\text{ k}\Omega$	360	400	440	kHz
	Switching frequency	$R_T = 8.87\text{ k}\Omega$	1953	2100	2247	kHz
$FS_{SS}$	Frequency span of spread spectrum operation			$\pm 6$		%
<b>BUS DISCHARGE</b>						
$t_{DEGA\_OUT\_DCHG}$	Discharge asserting deglitch		5.0	12.5	23.4	ms
$t_{W\_BUS\_DCHG}$	$V_{BUS}$ discharge time after sink termination removed from CC lines	$V_{BUS} = 1\text{ V}$ , time $I_{SNK\_OUT} > 1\text{ mA}$ after sink termination removed from CC lines	150	266	400	ms
<b>CC1/CC2 - VCONN POWER SWITCH 5.1 k<math>\Omega</math> on one CC pin and 1 k<math>\Omega</math> on the other</b>						
$t_r$	Output voltage rise time	$C_L = 1\text{ }\mu\text{F}$ , $R_L = 100\text{ }\Omega$ (measured from 10% to 90% of final value)	0.78	1.1	1.95	ms
$t_f$	Output voltage fall time		0.18	0.32	0.37	
$t_{on}$	Output voltage turnon-time	$C_L = 1\text{ }\mu\text{F}$ , $R_L = 100\text{ }\Omega$	4.1	6.2	8.5	ms
$t_{off}$	Output voltage turnoff time		0.5	1	1.6	
<b>CC1/CC2 VCONN POWER SWITCH: CURRENT LIMIT</b>						
$t_{IOS}$	Short circuit response time			15		$\mu\text{s}$
<b>CC1/CC2 - CONNECT MANAGEMENT - ATTACH AND DETACH DEGLITCH</b>						
$t_{DEGA\_CC\_ATT}$	Attach asserting deglitch		1.1	2.08	3.29	ms
$t_{DEGD\_CC\_DET}$	Detach asserting deglitch for exiting UFP state		6.98	12.7	19.4	ms
<b>CC1/CC2 - CONNECT MANAGEMENT - ATTACHED MODE 5.1-k<math>\Omega</math> or 1-k<math>\Omega</math> termination on at least one CC pin</b>						
$t_{DEGA\_CC\_SHORT}$	Detach, Rd and Ra asserting deglitch		78	195	366	$\mu\text{s}$
$t_{DEGA\_CC\_LONG}$	Long deglitch		87	150	217	ms
<b>CC1/CC2 - CONNECT MANAGEMENT - VCONN DISCHARGED MODE</b>						
$t_{W\_CC\_DCHG}$	Discharge wait time		37	66	99	ms
<b>NFET DRIVER</b>						
$t_r$	$V_{LS\_DR}$ rise time	$V_{OUT} = 5.1\text{ V}$ , NFET = CSD87502Q2, time from LS_GD 10% to 90%		1000		$\mu\text{s}$
$t_f$	$V_{LS\_DR}$ fall time	$V_{OUT} = 5.1\text{ V}$ , NFET = CSD87502Q2, time from LS_GD time 90% to 10%		100		$\mu\text{s}$
<b>CURRENT LIMIT - EXTERNAL NFET CONNECTED BETWEEN CSN/OUT AND BUS, LS_GD CONNECTED TO FET GATE</b>						
$t_{OC\_HIC\_ON}$	ON-time during hiccup mode			2		ms
$t_{OC\_HIC\_OFF}$	OFF-time during hiccup mode			263		ms
<b>FAULT DUE TO VBUS OC, VBUS OV, DP OV, DM OV, CC OV, CC OC</b>						
$t_{DEGLA}$	Asserting deglitch time		5.5	8.2	11.5	ms
$t_{DEGLD}$	De-asserting deglitch time		5.5	8.2	11.5	ms
<b>LD_DET, POL</b>						
$t_{DEGLA}$	Asserting deglitch time		88	150	220	ms
$t_{DEGLD}$	De-asserting deglitch time		7.0	12.7	19.4	ms
<b>THERM_WARN (TPS25831-Q1)</b>						
$t_{DEGLA}$	Asserting deglitch time			0		ms
$t_{DEGLD}$	De-asserting deglitch time			0		ms

## 8.7 Switching Characteristics (continued)

Limits apply over the junction temperature ( $T_J$ ) range of  $-40^{\circ}\text{C}$  to  $+150^{\circ}\text{C}$ ;  $V_{IN} = 13.5\text{ V}$ ,  $f_{SW} = 400\text{ kHz}$ ,  $C_{VCC} = 2.2\text{ }\mu\text{F}$ ,  $R_{SNS} = 15\text{ m}\Omega$ ,  $R_{IMON} = 13\text{ k}\Omega$ ,  $R_{LIMIT} = 13\text{ k}\Omega$ ,  $R_{SET} = 300\text{ }\Omega$  unless otherwise stated. Minimum and maximum limits are specified through test, design or statistical correlation. Typical values represent the most likely parametric norm at  $T_J = 25^{\circ}\text{C}$ , and are provided for reference purposes only.

PARAMETER		TEST CONDITIONS	MIN	TYP	MAX	UNIT
<b>HIGH-BANDWIDTH ANALOG SWITCH (TPS25830-Q1)</b>						
$t_{pd}$	Analog switch propagation delay			0.14		ns
$t_{SK}$	Analog switch skew between opposite transitions of the same port ( $t_{PHL} - t_{PLH}$ )			0.02		ns
$t_{OV\_Dn}$	DP_IN and DM_IN overvoltage protection response time			2		$\mu\text{s}$

TPS25830-Q1, TPS25831-Q1

ZHCSJV0G - JUNE 2018 - REVISED JULY 2021

### 8.8 Typical Characteristics

Unless otherwise specified the following conditions apply:  $V_{IN} = 13.5\text{ V}$ ,  $f_{SW} = 400\text{ kHz}$ ,  $L = 10\text{ }\mu\text{H}$ ,  $C_{OUT\_CSP} = 66\text{ }\mu\text{F}$ ,  $C_{OUT\_CSN} = 0.1\text{ }\mu\text{F}$ ,  $C_{BUS} = 1\text{ }\mu\text{F}$ ,  $T_A = 25\text{ }^\circ\text{C}$ .



图 8-1. Non-Switching Quiescent Current



图 8-2. Standby Quiescent Current

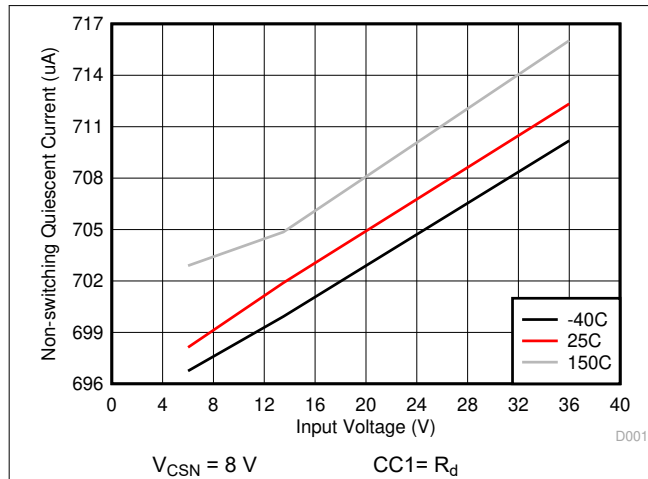

图 8-3. Shutdown Quiescent Current

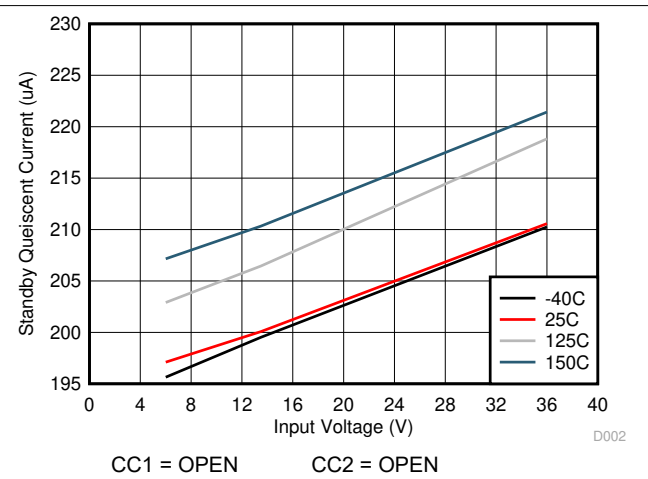

图 8-4. Precision Enable Threshold

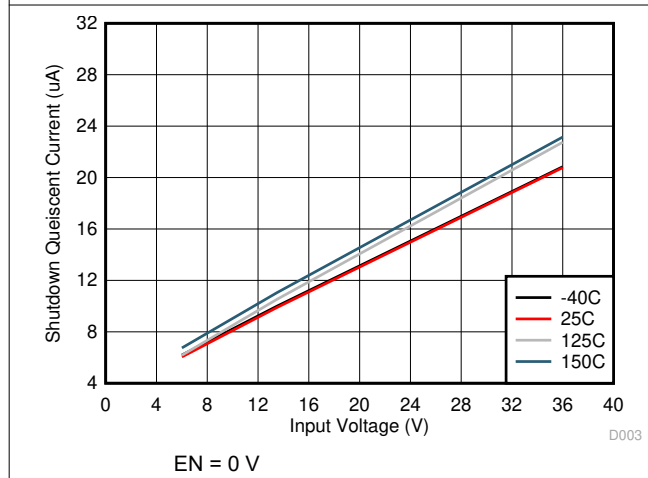

图 8-5. VIN UVLO Threshold

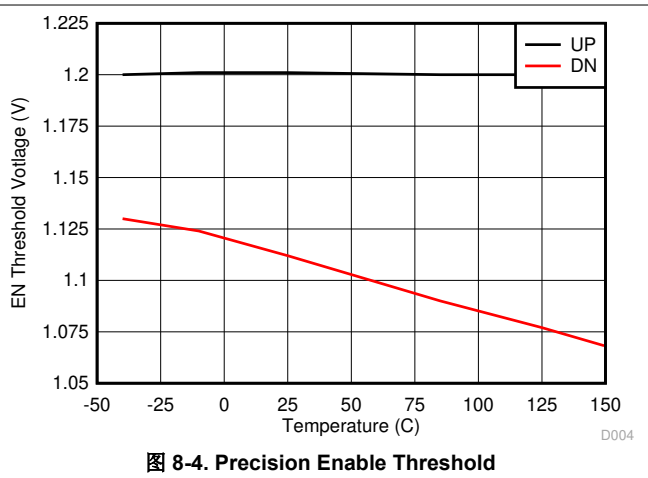

图 8-6. VCC vs Input Voltage

### 8.8 Typical Characteristics (continued)

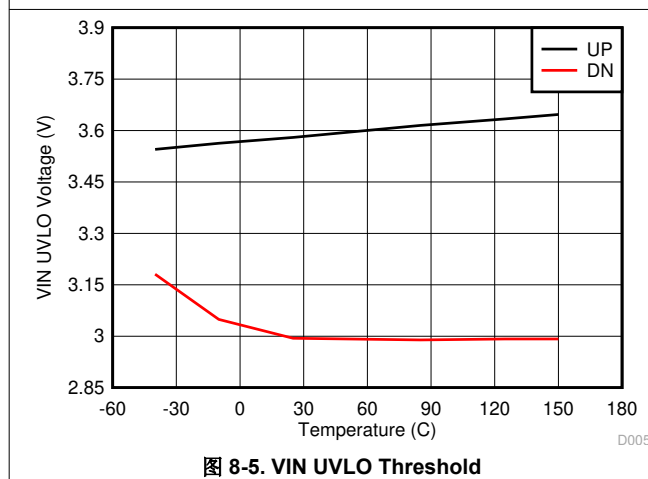
Unless otherwise specified the following conditions apply:  $V_{IN} = 13.5\text{ V}$ ,  $f_{SW} = 400\text{ kHz}$ ,  $L = 10\text{ }\mu\text{H}$ ,  $C_{OUT\_CSP} = 66\text{ }\mu\text{F}$ ,  $C_{OUT\_CSN} = 0.1\text{ }\mu\text{F}$ ,  $C_{BUS} = 1\text{ }\mu\text{F}$ ,  $T_A = 25\text{ }^\circ\text{C}$ .

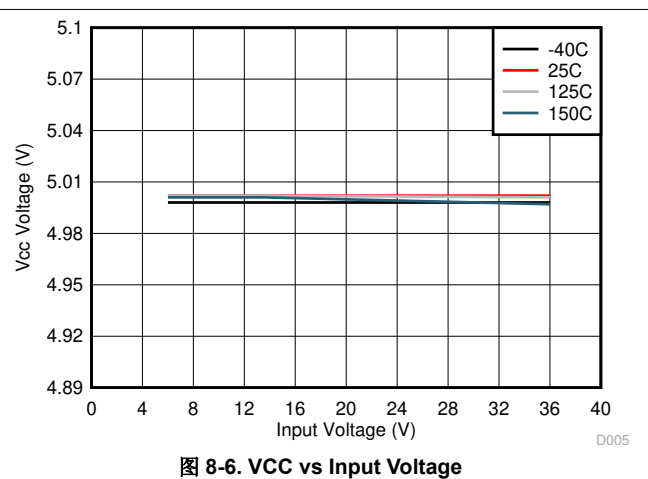

图 8-7.  $V_{CSN/OUT}$  Voltage vs Junction Temperature



图 8-8. High-side Current Limit vs Input Voltage

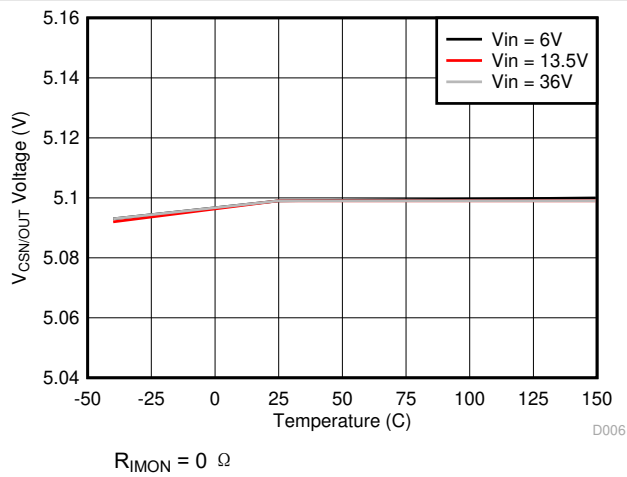

图 8-9. High-side MOSFET on Resistance vs Junction Temperature

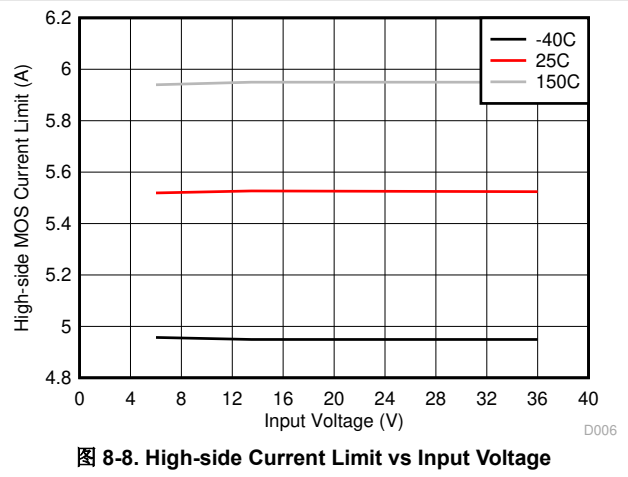

图 8-10. Low-side MOSFET on Resistance vs Junction Temperature

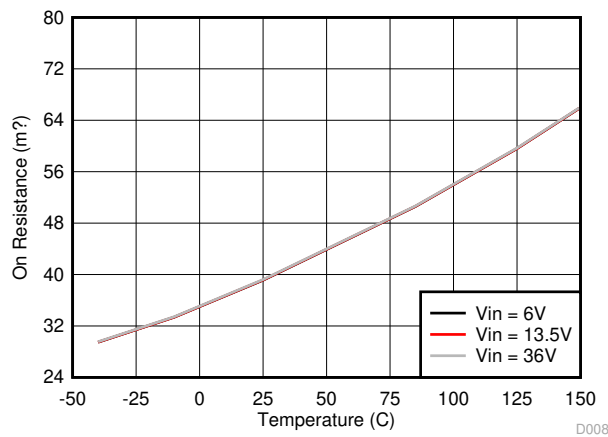

图 8-11. Switching Frequency vs Junction Temperature

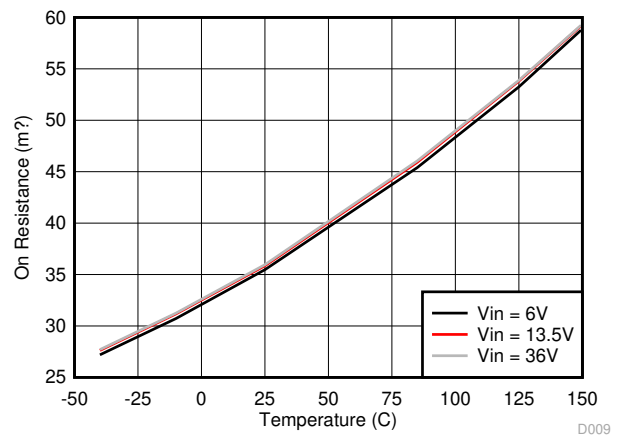

图 8-12. Switching Frequency vs VIN Voltage

### 8.8 Typical Characteristics (continued)

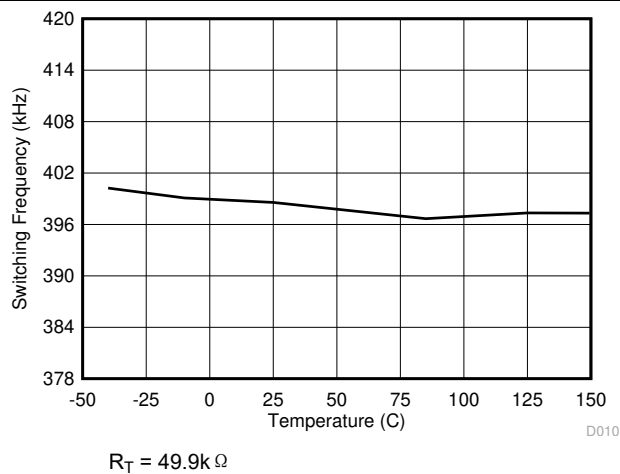
Unless otherwise specified the following conditions apply:  $V_{IN} = 13.5\text{ V}$ ,  $f_{SW} = 400\text{ kHz}$ ,  $L = 10\text{ }\mu\text{H}$ ,  $C_{OUT\_CSP} = 66\text{ }\mu\text{F}$ ,  $C_{OUT\_CSN} = 0.1\text{ }\mu\text{F}$ ,  $C_{BUS} = 1\text{ }\mu\text{F}$ ,  $T_A = 25\text{ }^\circ\text{C}$ .

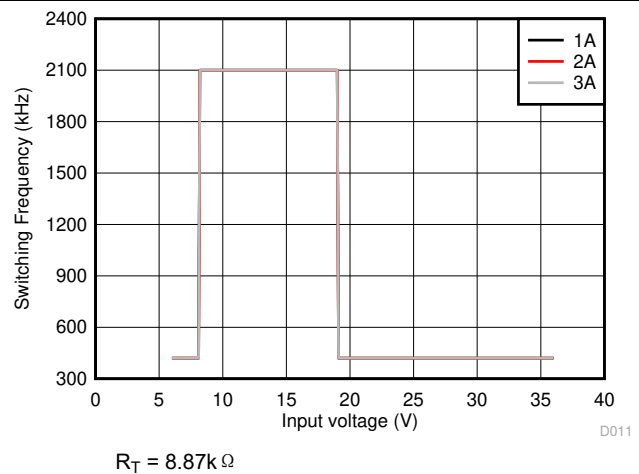

图 8-13. Buck Average Current Limit vs Junction Temperature



图 8-14. External FET Current Limit vs Junction Temperature

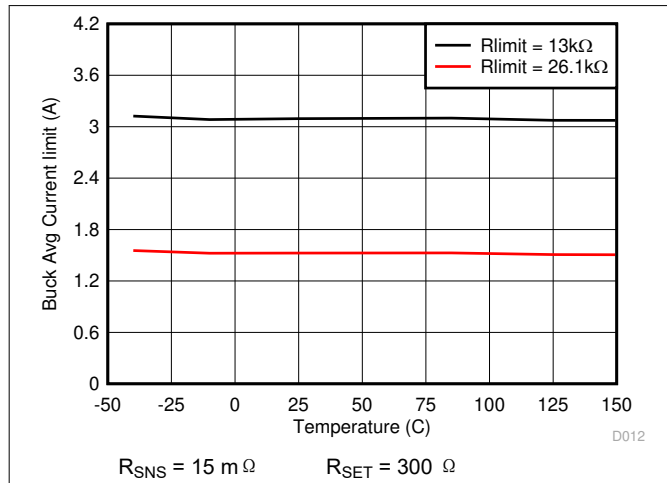

图 8-15. LS\_GD Gate Source Current vs Junction Temperature

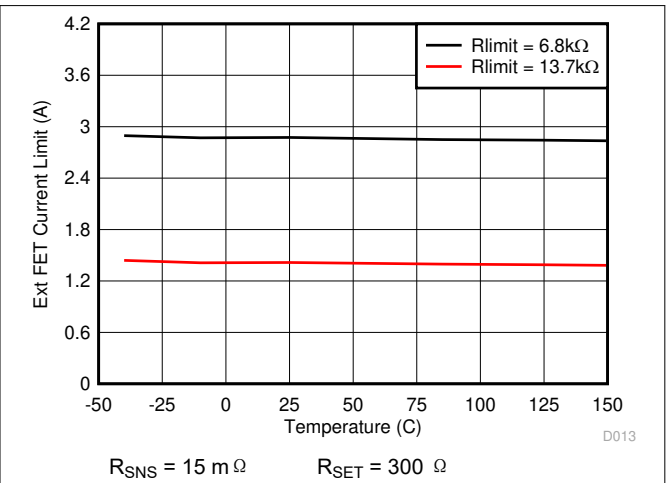

图 8-16. LS\_GD Gate Voltage vs Junction Temperature

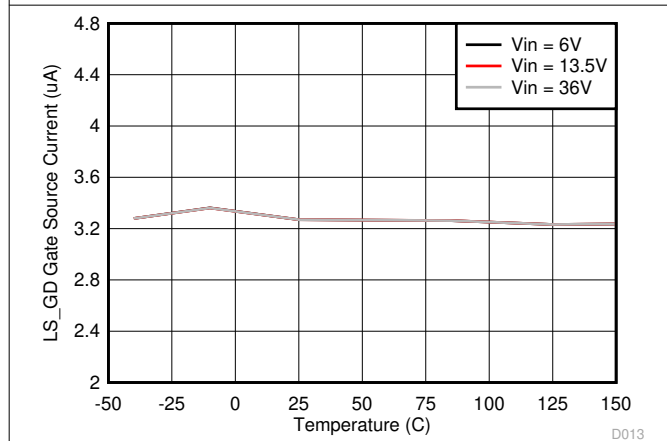

图 8-17. Cable Compensation Voltage vs Junction Temperature

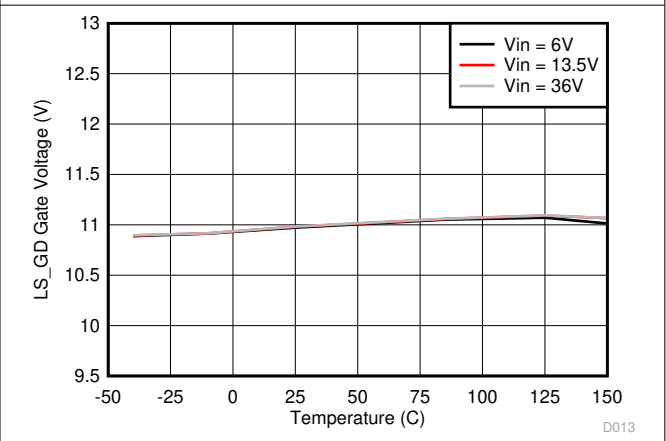

图 8-18. Cable Compensation Voltage vs Load Current

## 8.8 Typical Characteristics (continued)

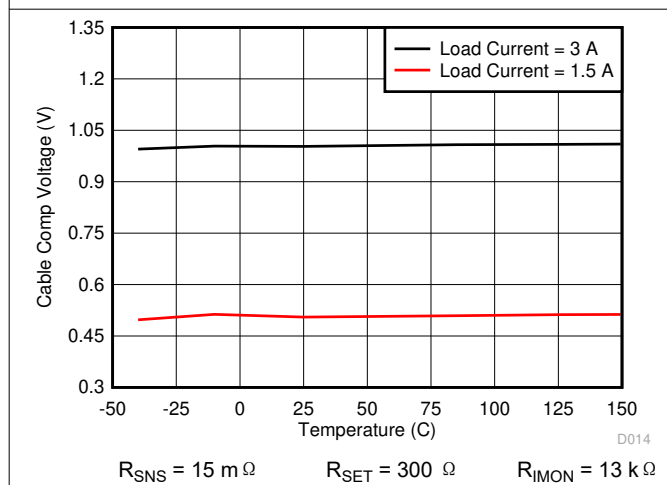
Unless otherwise specified the following conditions apply:  $V_{IN} = 13.5\text{ V}$ ,  $f_{SW} = 400\text{ kHz}$ ,  $L = 10\text{ }\mu\text{H}$ ,  $C_{OUT\_CSP} = 66\text{ }\mu\text{F}$ ,  $C_{OUT\_CSN} = 0.1\text{ }\mu\text{F}$ ,  $C_{BUS} = 1\text{ }\mu\text{F}$ ,  $T_A = 25\text{ }^\circ\text{C}$ .

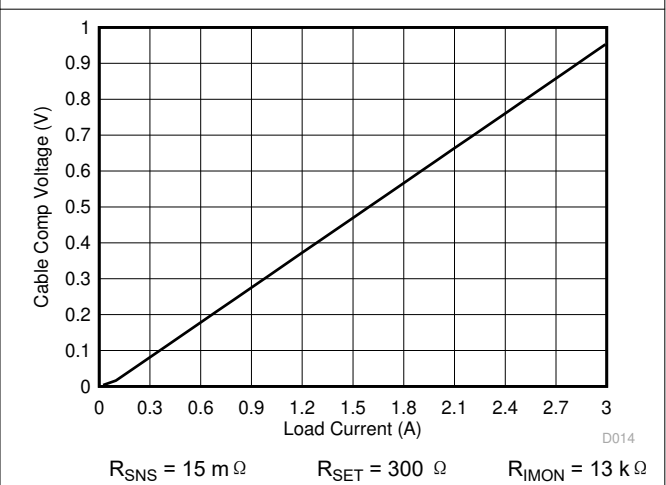

图 8-19. V<sub>BUS</sub> Discharge Resistance vs Junction Temperature



图 8-20. V<sub>BUS</sub> Overvoltage Protection Threshold vs Junction Temperature

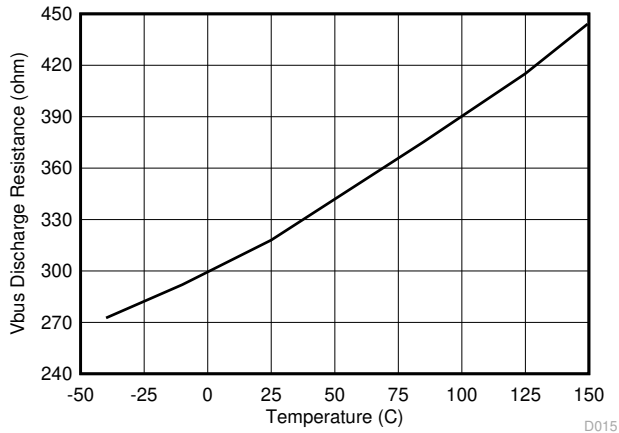

图 8-21. DP\_IN Overvoltage Protection Threshold vs Junction Temperature

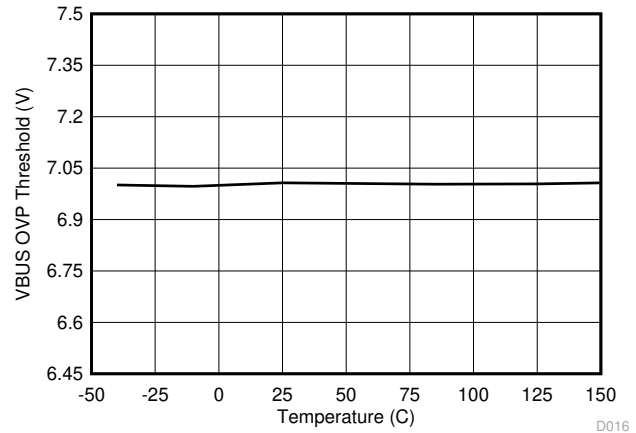

图 8-22. DM\_IN Overvoltage Protection Threshold vs Junction Temperature

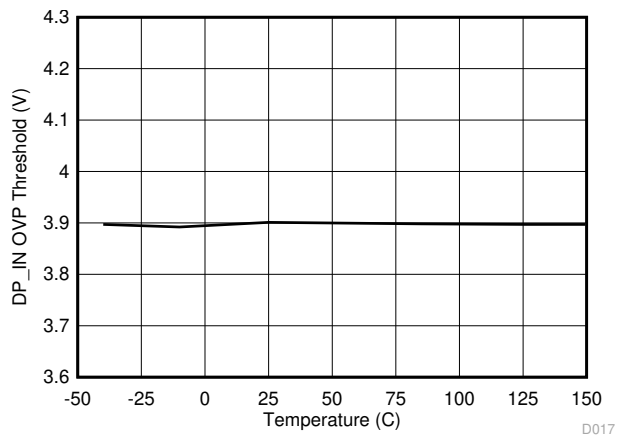

图 8-23. V<sub>CONN</sub> Current Limiting Switch On Resistance vs Junction Temperature

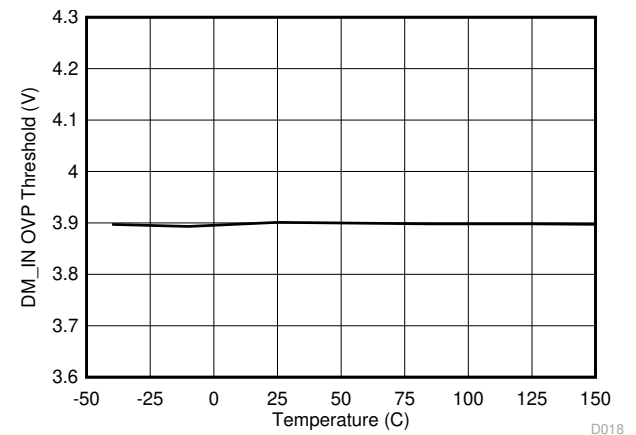

图 8-24. V<sub>CONN</sub> Switch Current Limit vs Junction Temperature

TPS25830-Q1, TPS25831-Q1

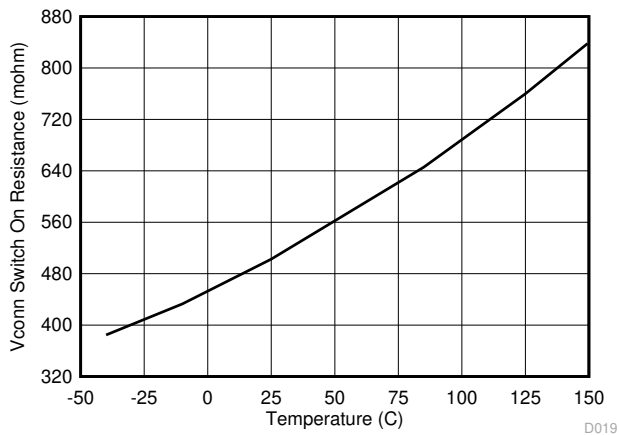
ZHCSJV0G – JUNE 2018 – REVISED JULY 2021

8.8 Typical Characteristics (continued)

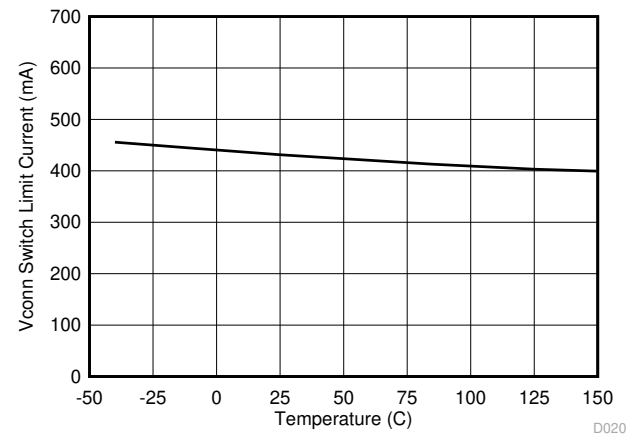
Unless otherwise specified the following conditions apply:  $V_{IN} = 13.5\text{ V}$ ,  $f_{SW} = 400\text{ kHz}$ ,  $L = 10\text{ }\mu\text{H}$ ,  $C_{OUT\_CSP} = 66\text{ }\mu\text{F}$ ,  $C_{OUT\_CSN} = 0.1\text{ }\mu\text{F}$ ,  $C_{BUS} = 1\text{ }\mu\text{F}$ ,  $T_A = 25\text{ }^\circ\text{C}$ .



图 8-25. CC Sourcing Current vs Junction Temperature



图 8-26. CC1 Overvoltage Protection Threshold vs Junction Temperature

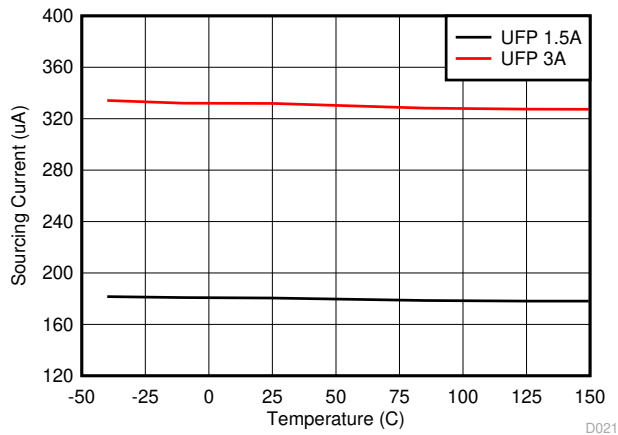

图 8-27. NTC Temperature Warning Threshold (TPS25831-Q1)

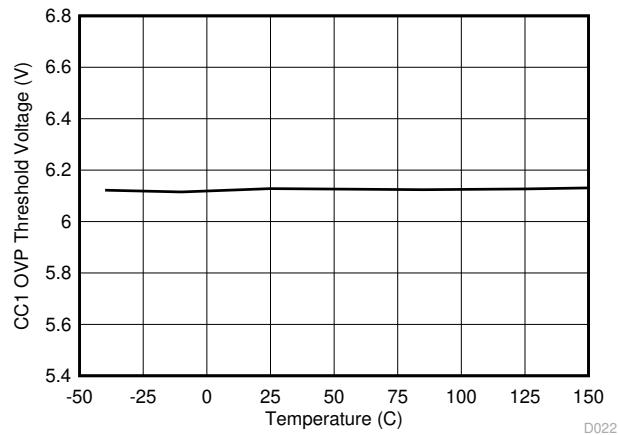

图 8-28. NTC Temperature Shutdown Threshold (TPS25831-Q1)

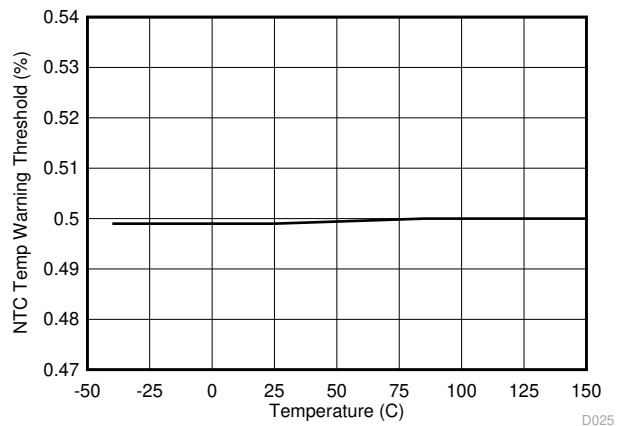

Measured Source with 10-cm cable

图 8-29. Bypassing the TPS25830-Q1 Data Switch

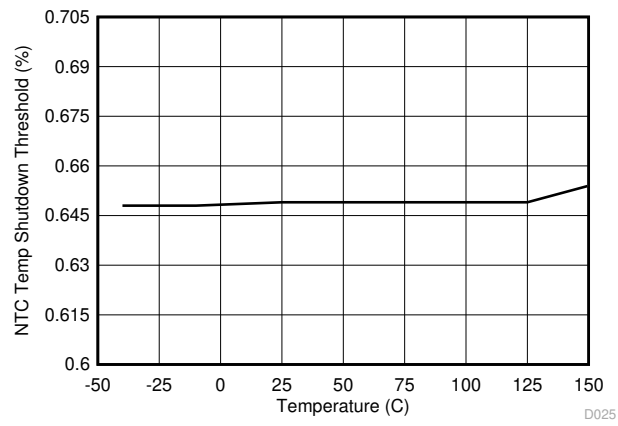
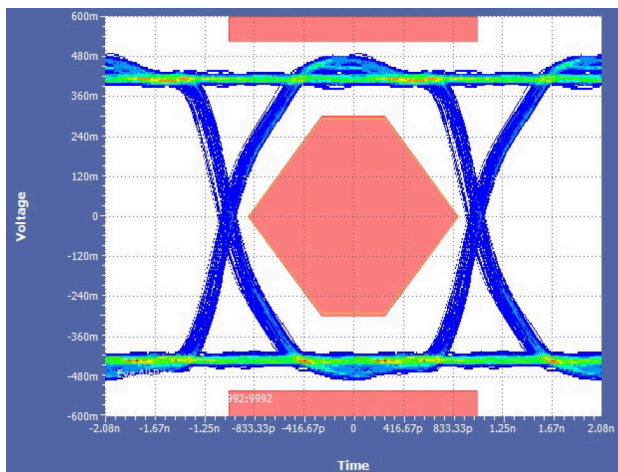
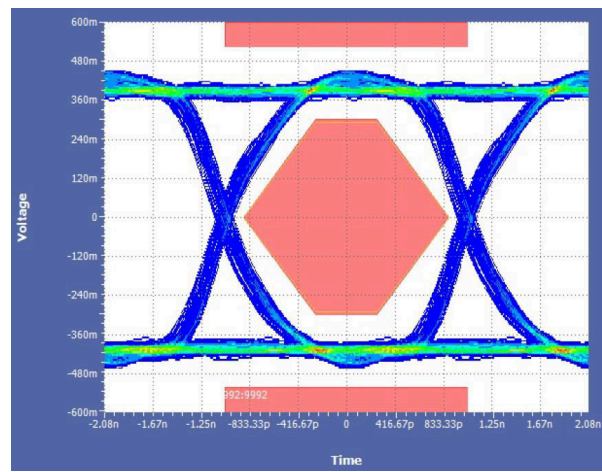

Measured on TPS25830-Q1 EVM with 10-cm cable

图 8-30. Through the TPS25830-Q1 Data Switch

### 8.8 Typical Characteristics (continued)

Unless otherwise specified the following conditions apply:  $V_{IN} = 13.5\text{ V}$ ,  $f_{SW} = 400\text{ kHz}$ ,  $L = 10\text{ }\mu\text{H}$ ,  $C_{OUT\_CSP} = 66\text{ }\mu\text{F}$ ,  $C_{OUT\_CSN} = 0.1\text{ }\mu\text{F}$ ,  $C_{BUS} = 1\text{ }\mu\text{F}$ ,  $T_A = 25\text{ }^\circ\text{C}$ .



图 8-31. Data Transmission Characteristics vs Frequency (TPS25830-Q1)



图 8-32. Off-State Data-Switch Isolation vs Frequency (TPS25830-Q1)

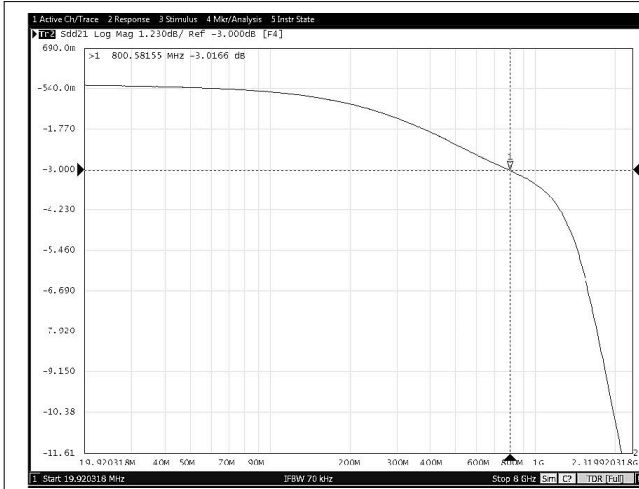

图 8-33. On-State Cross-Channel Isolation vs Frequency (TPS25830-Q1)

## 9 Parameter Measurement Information



图 9-1.  $V_{CONN}$  Switch Rise-Fall Test Load Figure

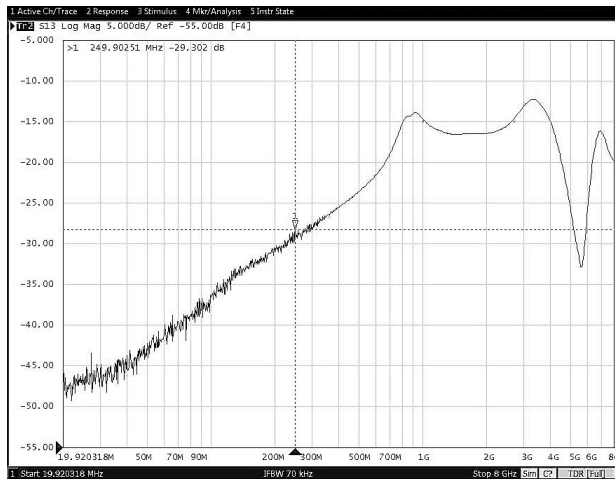

图 9-2.  $V_{CONN}$  Switch Rise-Fall Timing

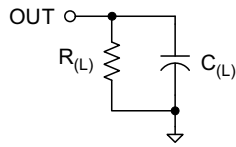

图 9-3. Short-Circuit Parameters

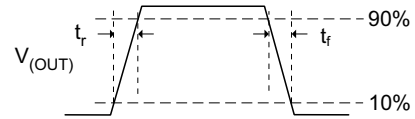

图 9-4. NFET Gate Drive Rise and Fall Time

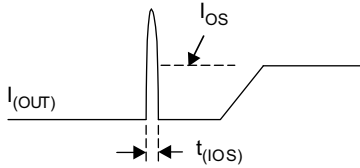

图 9-5. Short-to-Battery System Test Setup

## 10 Detailed Description

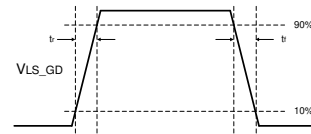
### 10.1 Overview

The TPS25830-Q1 and TPS25831-Q1 are full-featured solutions for implementing a compact USB charging port with support for both Type-C and BC1.2 standards. Both devices contain an efficient 36-V buck regulator power source capable of providing up to 3.5 A of output current at 5.10 V (nominal). System designers can optimize efficiency or solution size through careful selection of switching frequency over the range of 300 to 2200 kHz with sufficient margin to operate above or below the AM radio frequency band. In devices, the buck regulator operates in forced PWM mode ensuring fixed switching frequency regardless of load current. Spread-spectrum frequency dithering reduces harmonic peaks of the switching frequency potentially simplifying EMI filter design and easing compliance.

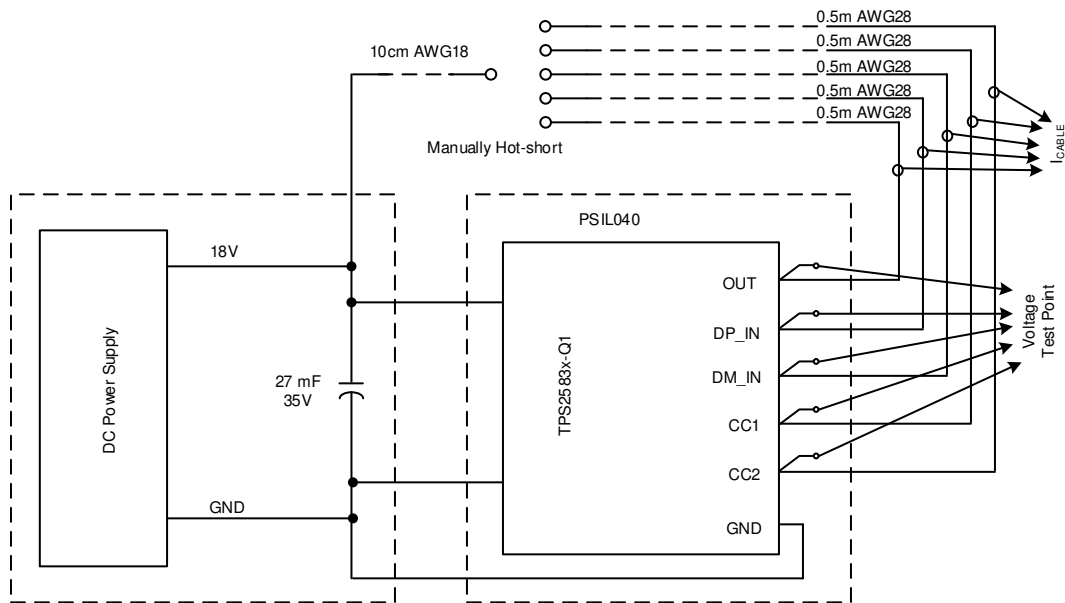
Current sensing with a precision high-side current sense amplifier enables an accurate, user programmable overcurrent limit setting; and programmable linear cable compensation to overcome IR losses when powering remote USB ports.

The TPS25830-Q1 integrates high band-width (800 MHz) USB switches and includes short-to- $V_{BAT}$  and short-to- $V_{BUS}$  protection as well as IEC61000-4-2 electrostatic discharge clamps to protect the host from potentially damaging overvoltage conditions. The CTRL1 and CTRL2 pins set the operating mode for the TPS25830-Q1 implementing Type-C, CDP and SDP USB port configurations.

The TPS25831-Q1 includes an NTC input and  $\overline{THERM\_WARN}$  flag for user programmable thermal protection using a negative temperature coefficient resistor. The CTRL1 and CTRL2 pins set the operating mode for the TPS25831-Q1, implementing Type-C, DCP, CDP and SDP USB ports.

## 10.2 Functional Block Diagram

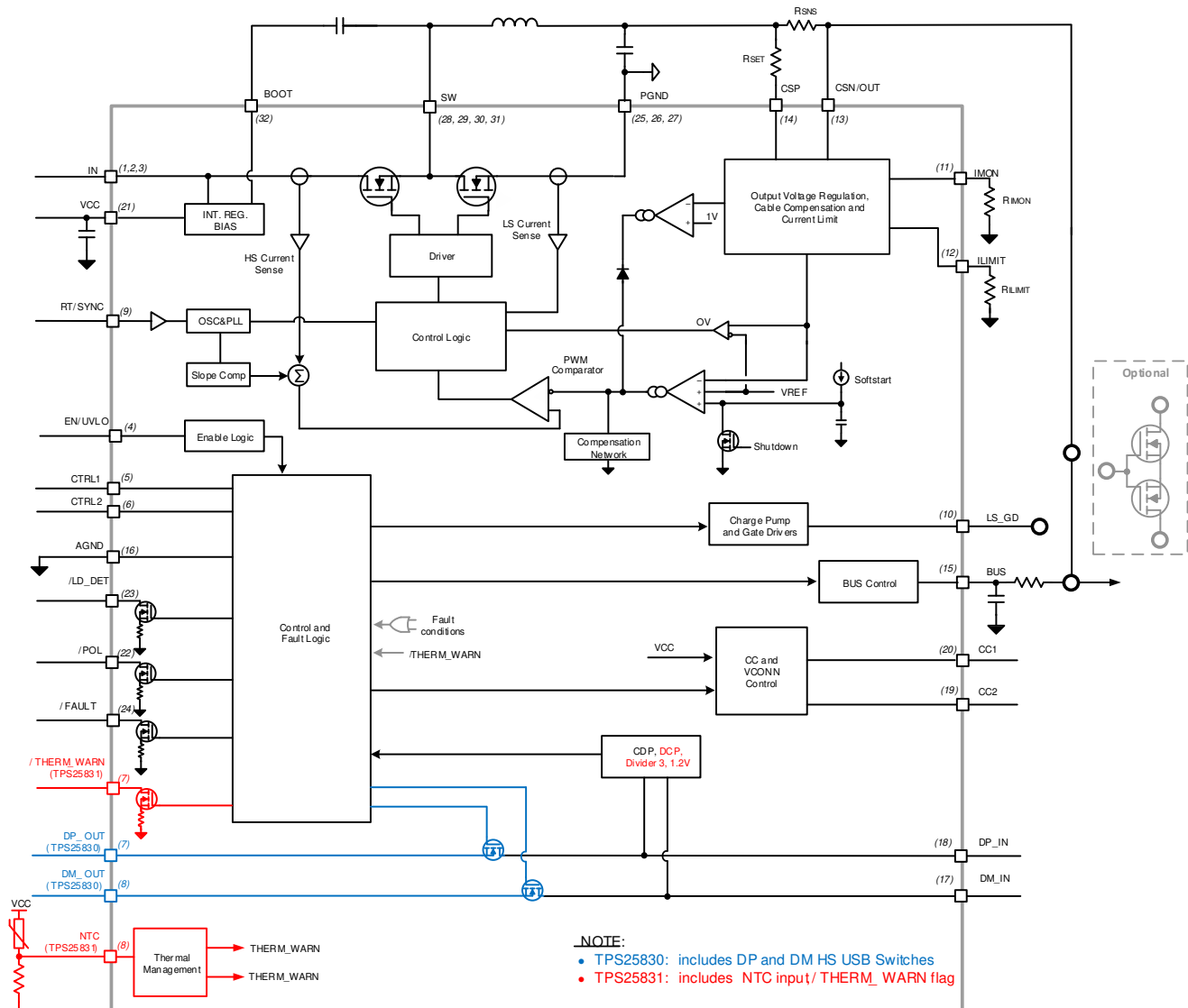

## 10.3 Feature Description

### 10.3.1 Buck Regulator

The following operating description of the TPS25830-Q1, TPS25831-Q1 will refer to the *Functional Block Diagram* and to the waveforms in [Figure 10-1](#). TPS2583x-Q1 is a step-down synchronous buck regulator with integrated high-side (HS) and low-side (LS) switches (synchronous rectifier). The TPS2583x-Q1 supplies a regulated output voltage by turning on the HS and LS NMOS switches with controlled duty cycle. During high-side switch ON time, the SW pin voltage swings up to approximately  $V_{IN}$ , and the inductor current  $i_L$  increase with linear slope  $(V_{IN} - V_{OUT}) / L$ . When the HS switch is turned off by the control logic, the LS switch is turned on after an anti-shoot-through dead time. Inductor current discharges through the LS switch with a slope of  $-V_{OUT} / L$ . The control parameter of a buck converter is defined as Duty Cycle  $D = t_{ON} / T_{SW}$ , where  $t_{ON}$  is the high-side switch ON time and  $T_{SW}$  is the switching period. The regulator control loop maintains a constant output voltage by adjusting the duty cycle  $D$ . In an ideal buck converter, where losses are ignored,  $D$  is proportional to the output voltage and inversely proportional to the input voltage:  $D = V_{OUT} / V_{IN}$ .

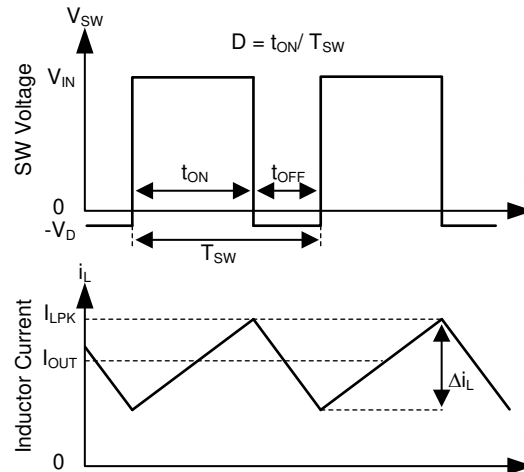

**图 10-1. SW Node and Inductor Current Waveforms in Continuous Conduction Mode (CCM)**

The TPS2583x-Q1 employs fixed frequency peak current mode control. A voltage feedback loop is used to get accurate DC voltage regulation by adjusting the peak current command based on voltage offset. The peak inductor current is sensed from the high-side switch and compared to the peak current threshold to control the ON time of the high-side switch. The voltage feedback loop is internally compensated, which allows for fewer external components, makes it easy to design, and provides stable operation with a reasonable combination of output capacitors. TPS2583x-Q1 operates in FPWM mode for low output voltage ripple, tight output voltage regulation, and constant switching frequency.

### 10.3.2 Enable/UVLO and Start-up

The voltage on the EN/UVLO pin controls the ON or OFF operation of TPS2583x-Q1. An EN/UVLO pin voltage higher than  $V_{EN/UVLO-H}$  is required to start the internal regulator and begin monitoring the CCn lines for a valid Type-C connection. The internal USB monitoring circuitry is on when  $V_{IN}$  is within the operation range and the EN/UVLO threshold is cleared; however, the buck regulator does not begin operation until a valid USB Type-C detection has been made. This feature ensures the "cold socket" (0 V) USB Type-C  $V_{BUS}$  requirement is met. The EN/UVLO pin is an input and cannot be left open or floating. The simplest way to enable the operation of the TPS2583x-Q1 is to connect the EN to  $V_{IN}$ . This connection allows self-start-up of the TPS2583x-Q1 when  $V_{IN}$  is within the operation range.



图 10-2. Precision Enable Behavior

Many applications will benefit from the employment of an enable divider,  $R_{ENT}$  and  $R_{ENB}$ , (图 10-3) to establish a precision system UVLO level for the TPS2583x-Q1. The system UVLO can be used for sequencing, ensuring reliable operation, or supply protection, such as a battery discharge level. To ensure the USB port  $V_{BUS}$  is within the 5-V operating range as required for USB compliance (for the latest USB specifications and requirements, refer to [USB.org](http://USB.org)), TI suggests that the  $R_{ENT}$  and  $R_{ENB}$  resistors be chosen so that the TPS2583x-Q1 enables when  $V_{IN}$  is approximately 6 V. Considering the drop out voltage of the buck regulator and IR losses in the system, 6 V provides adequate margin to maintain  $V_{BUS}$  within USB specifications. If system requirements such as a warm crank (start) automotive scenario require operation with  $V_{IN} < 6$  V, the values of  $R_{ENT}$  and  $R_{ENB}$  can be calculated assuming a lower  $V_{IN}$ . An external logic signal can also be used to drive EN/UVLO input when a microcontroller is present and it is desirable to enable or disable the USB port remotely for other reasons.

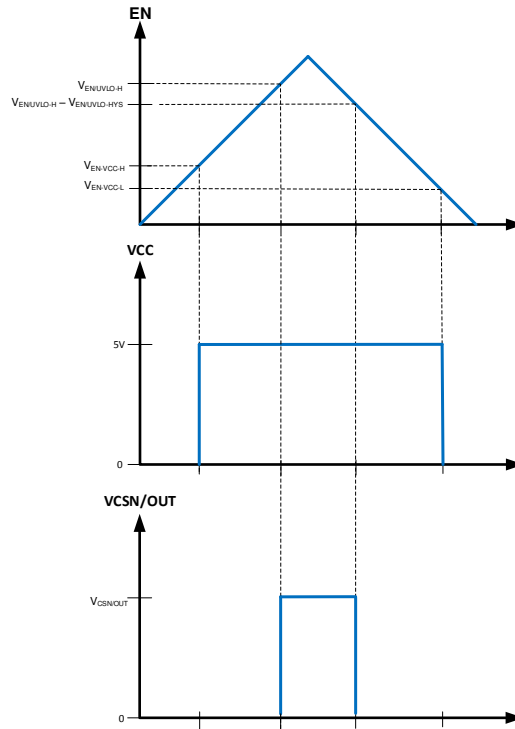

图 10-3. System UVLO by Enable Divider

UVLO configuration using external resistors is governed by the following equations:

$$R_{ENT} = \left( \frac{V_{IN(ON)}}{V_{EN/UVLO\_H}} - 1 \right) \times R_{ENB} \quad (1)$$

$$V_{IN(OFF)} = V_{IN(ON)} \times \left( 1 - \frac{V_{EN/UVLO\_HYS}}{V_{EN/UVLO\_H}} \right) \quad (2)$$

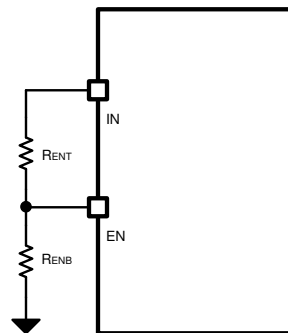
Example:

$V_{IN(ON)} = 6 \text{ V}$  (user choice)

$R_{ENB} = 5 \text{ k}\Omega$  (user choice)

$R_{ENT} = [(V_{IN(ON)} / V_{EN/UVLO\_H}) - 1] \times R_{ENB} = 19.6 \text{ k}\Omega$ . Choose standard  $20 \text{ k}\Omega$ .

Therefore  $V_{IN(OFF)} = 6 \text{ V} \times [1 - (0.09 \text{ V} / 1.2 \text{ V})] = 5.55 \text{ V}$

图 10-4 shows a typical start-up waveform, indicating typical timings when  $R_d$  connected to CC line. The rise time of DCDC VBUS voltage is about 5 ms.



图 10-4. Typical Start-up Behavior,  $V_{IN} = 13.5 \text{ V}$ ,  $CC1 = R_d$ ,  $R_{IMON} = 12.6 \text{ k}\Omega$

For TPS25830-Q1, the pin voltage must meet the requirement below during 150 ms (typical)  $R_d$  assert deglitch time. See 图 10-5:

- $V_{BUS} < 0.8 \text{ V}$  (typical), per Type-C requirement
- $V_{DX\_OUT} < 2.2 \text{ V}$  (typical)
- $V_{DX\_IN} < 1.5 \text{ V}$  (typical)

After the TPS25830-Q1  $R_d$  assert deglitch time, there is no additional requirement on these pins. In real application,  $\overline{LD\_DET}$  pin can be used to configure the timing sequence.

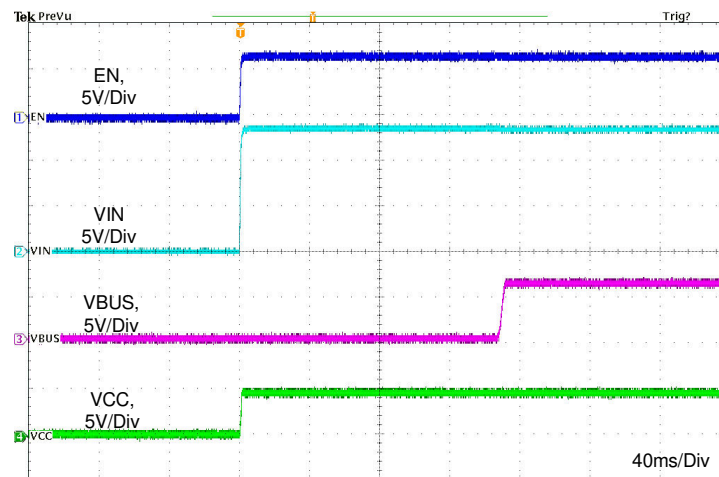

图 10-5. TPS25830-Q1 Pin Voltage Requirement During Rd Assert

### 10.3.3 Switching Frequency and Synchronization (RT/SYNC)

The switching frequency of the TPS2583x-Q1 can be programmed by the resistor,  $R_T$ , from the RT/SYNC pin and GND pin. Use Equation 3 to determine the RT resistance, for a given switching frequency:

$$R_{FREQ} (k\Omega) = 26660 \times f_{SW}^{-1.0483} (kHz) \quad (3)$$

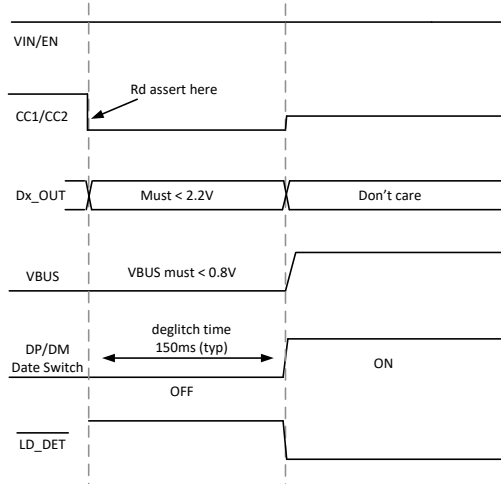

图 10-6. RT Set Resistor vs Switching Frequency

表 10-1 lists typical RT resistors value.

表 10-1. Setting the Switching Frequency with RT

RT (kΩ)	SWITCHING FREQUENCY (kHz)
68.1	300
49.9	400
39.2	500
19.1	1000
12.4	1500
9.31	2000
8.87	2100
8.45	2200

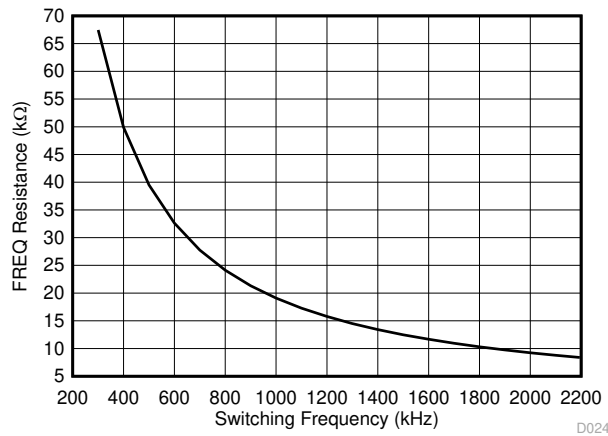
TPS2583x-Q1 switching action can be synchronized to an external clock from 300 kHz to 2.3 MHz. The RT/SYNC pin can be used to synchronize the internal oscillator to an external clock. The internal oscillator can be synchronized by AC coupling a positive edge into the RT/SYNC pin. The AC coupled peak-to-peak voltage at the RT/SYNC pin must exceed the SYNC amplitude threshold of 3.5 V (typical) to trip the internal synchronization pulse detector, and the minimum SYNC clock ON and OFF time must be longer than 100 ns (typical). When using a low impedance signal source, the frequency setting resistor,  $R_T$ , is connected in parallel with an AC coupling capacitor,  $C_{COUP}$ , to a termination resistor,  $R_{TERM}$ , (for example, 50  $\Omega$ ). The two resistors in series provide the default frequency setting resistance when the signal source is turned off. A 10-pF ceramic capacitor can be used for  $C_{COUP}$ . 图 10-7 shows the device synchronized to an external clock.



图 10-7. Synchronize to External Clock

In order to avoid AM radio frequency band and maintain proper regulation when minimum ON-time or minimum OFF-time is reached, the TPS2583x-Q1 implement frequency foldback scheme depends on  $V_{IN}$  voltage,. Refer to 图 8-11.

- When  $8\text{ V} < V_{IN} \leq 19\text{ V}$ , the switching frequency of TPS2583x-Q1 is determined by  $R_T$  resistor or external sync clock.
- When  $V_{IN} \leq 8\text{ V}$ , the switching frequency of TPS2583x-Q1 is set to default 420 kHz, regardless of  $R_T$  resistor setting or external sync clock.
- When  $V_{IN} > 19\text{ V}$ , the switching frequency of TPS2583x-Q1 is set to default 420 kHz, regardless of  $R_T$  resistor setting or external sync clock

图 10-8, 图 10-9 and 图 10-10 show the device switching frequency and behavior under different  $V_{IN}$  voltage and  $R_T = 8.87\text{ k}\Omega$ .

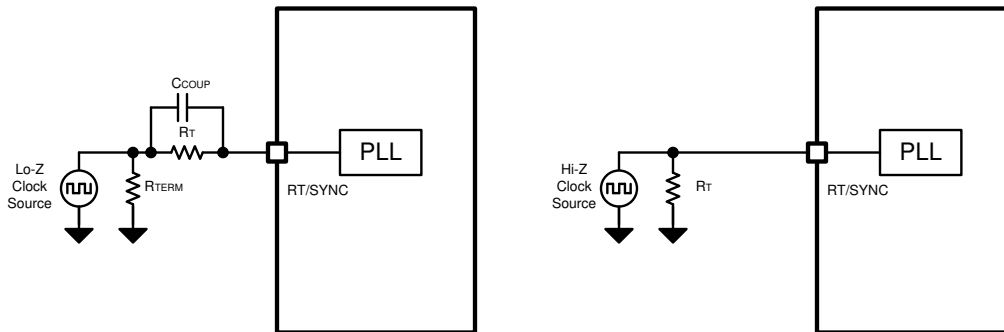
图 10-11, 图 10-12 and 图 10-13 show the device switching frequency and behavior under different  $V_{IN}$  voltage and synchronized to an external 2.1-M system clock.

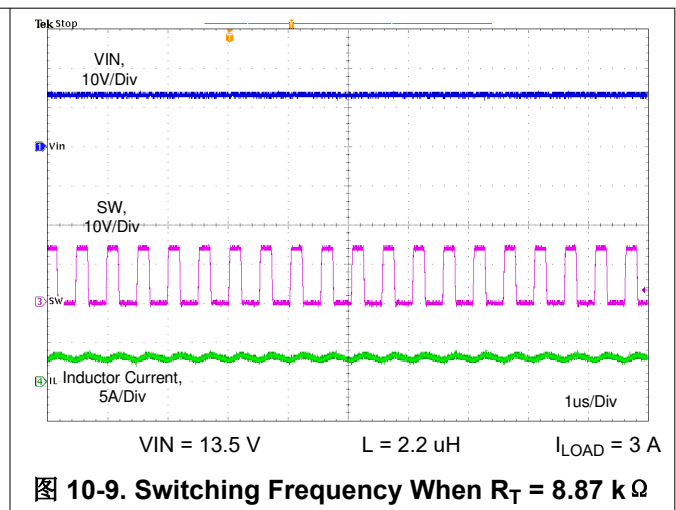
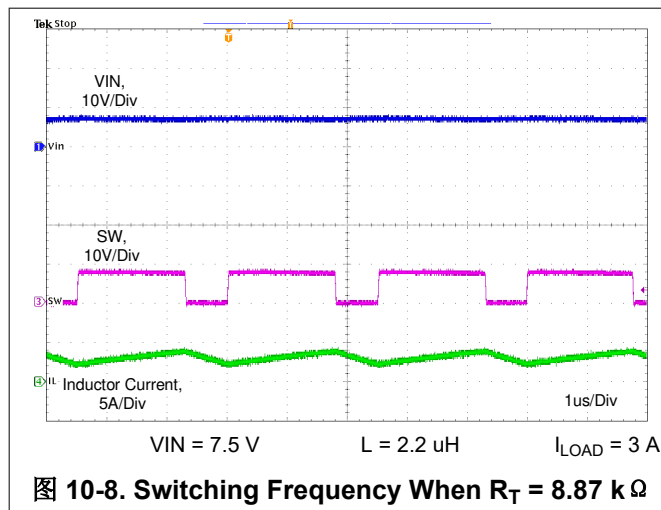

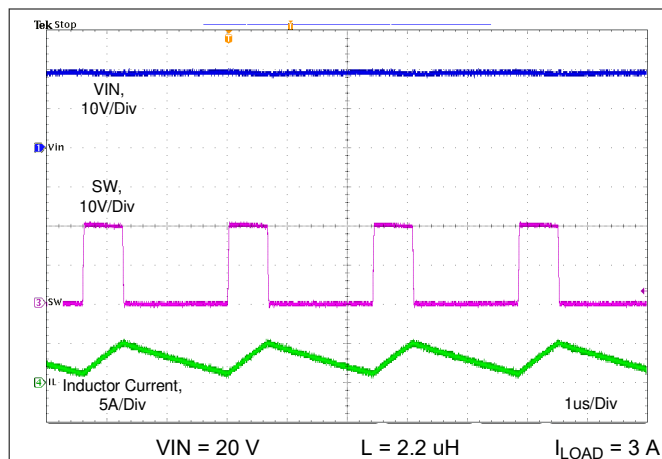
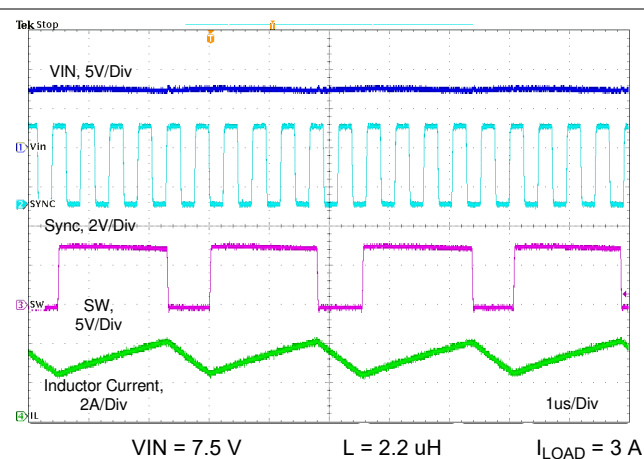
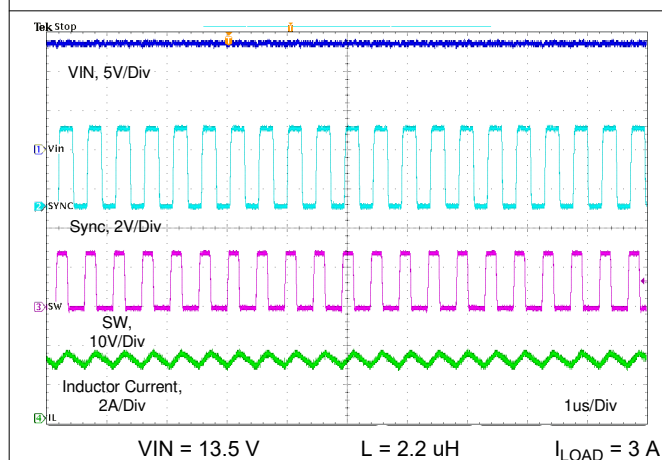
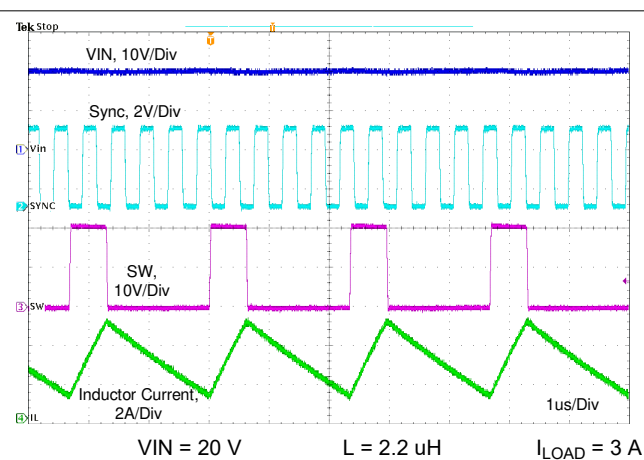
**图 10-10. Switching Frequency When  $R_T = 8.87 \text{ k}\Omega$** 

**图 10-11. Synchronizing to External 2.1-MHz Clock**

**图 10-12. Synchronizing to External 2.1-MHz Clock**

**图 10-13. Synchronizing to External 2.1-MHz Clock**

### 10.3.4 Spread-Spectrum Operation

In order to reduce EMI, the TPS2583x-Q1 introduce frequency spread spectrum. The spread spectrum is used to eliminate peak emissions at specific frequencies by spreading emissions across a wider range of frequencies than a part with fixed frequency operation. In most systems, low frequency conducted emissions from the first few harmonics of the switching frequency can be easily filtered. A more difficult design criterion is reduction of emissions at higher harmonics which fall in the FM band. These harmonics often couple to the environment through electric fields around the switch node. The TPS2583x-Q1 devices use  $\pm 6\%$  spread of switching frequencies with 1/256 swing frequency.

The spread spectrum function is only available when using the TPS2583x-Q1 internal oscillator. If the RT/SYNC pin is synchronized to an external clock, the spread spectrum function will be turned off.

### 10.3.5 VCC, VCC\_UVLO

The TPS2583x-Q1 integrates an internal LDO to generate  $V_{CC}$  for control circuitry and MOSFET drivers. The nominal voltage for  $V_{CC}$  is 5 V. The  $V_{CC}$  pin is the output of an LDO and must be properly bypassed. A high quality ceramic capacitor with a value of 2.2  $\mu\text{F}$  to 4.7  $\mu\text{F}$ , 10 V or higher rated voltage should be placed as close as possible to  $V_{CC}$  and grounded to the PGND ground pin. The  $V_{CC}$  output pin should not be loaded with more than 5 mA, or shorted to ground during operation.

In applications where  $V_{CONN}$  support is required, the  $V_{CC}$  pin can be over-driven with an external 5-V LDO capable of sourcing at least 300 mA. In this operating mode the external LDO is the source for the buck low-side switch gate drive as well as power to the internal  $V_{CONN}$  mux.

Note if using external 5-V LDO for  $V_{CONN}$  power, the timing sequence below must be required. External  $V_{CONN}$  power can not be enabled before the TPS2583x-Q1 is enabled, external  $V_{CONN}$  must be disabled before the TPS2583x-Q1 is disabled. In real application, customer can tie the EN of external 5-V LDO and EN of TPS2583x-Q1 together to meet the timing requirement.



图 10-14.  $V_{CONN}$  Source Using External LDO

### 10.3.6 Minimum ON-time, Minimum OFF-time

Minimum ON-time,  $T_{ON\_MIN}$ , is the smallest duration of time that the HS switch can be on.  $T_{ON\_MIN}$  is typically 105 ns in the TPS2583x. Minimum OFF-time,  $T_{OFF\_MIN}$ , is the smallest duration that the HS switch can be off.  $T_{OFF\_MIN}$  is typically 80 ns in the TPS2583x-Q1. In CCM (FPWM) operation,  $T_{ON\_MIN}$  and  $T_{OFF\_MIN}$  limit the voltage conversion range given a selected switching frequency.

The minimum duty cycle allowed is:

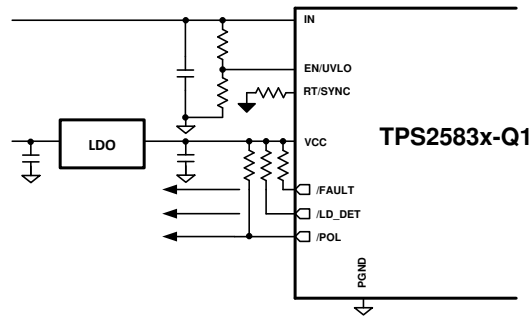
$$D_{MIN} = T_{ON\_MIN} \times f_{sw} \quad (4)$$

And the maximum duty cycle allowed is:

$$D_{MAX} = 1 - T_{OFF\_MIN} \times f_{sw} \quad (5)$$

Given fixed  $T_{ON\_MIN}$  and  $T_{OFF\_MIN}$ , the higher the switching frequency the narrower the range of the allowed duty cycle.

### 10.3.7 Internal Compensation

The TPS2583x-Q1 is internally compensated as shown in 图 10-1. The internal compensation is designed such that the loop response is stable over the specified operating frequency and output voltage range. The TPS2583x-Q1 is optimized for transient response over the range  $300 \text{ kHz} \leq f_{sw} \leq 2300 \text{ kHz}$ .

### 10.3.8 Bootstrap Voltage (BOOT)

The TPS2583x-Q1 provides an integrated bootstrap voltage regulator. A small capacitor between the BOOT and SW pins provides the gate drive voltage for the high-side MOSFET. The BOOT capacitor is refreshed when the high-side MOSFET is off and the low-side switch conducts. The recommended value of the BOOT capacitor is  $0.1 \mu\text{F}$ . A ceramic capacitor with an X7R or X5R grade dielectric with a voltage rating of 10 V or higher is recommended for stable performance over temperature and voltage.

### 10.3.9 $R_{SNS}$ , $R_{SET}$ , $R_{LIMIT}$ and $R_{IMON}$

The programmable current limit threshold and full-scale cable compensation voltage are determined by the values of the  $R_{SNS}$ ,  $R_{SET}$ ,  $R_{LIMIT}$ , and  $R_{IMON}$  resistors. Refer to 图 10-15.

- $R_{SNS}$  is the current sense resistor. The recommended voltage across  $R_{SNS}$  under current limit should be approximately 50 mV as a compromise between accuracy and power dissipation. For example, if current

limiting is desired for  $I_{OUT(MAX)} \geq 3.3 \text{ A}$ , then  $R_{SNS} = 0.05 \text{ V} / 3.3 \text{ A} = 0.01515 \ \Omega$ . Choose a standard value of  $15 \text{ m}\Omega$ .

- $R_{SET}$  determines the input current to the transconductance amplifier and current mirror. The amplifier balances the voltage to be equal to that across  $R_{SNS}$ . Choose a  $R_{SET}$  value to produce an  $I_{SET}$  current bfrom  $75 - 180 \ \mu\text{A}$  at the desired  $I_{OUT(MAX)}$ . Considering  $50 \text{ mV}$  across  $R_{SET}$ , a value of  $300 \ \Omega$  will provide approximately  $166 \ \mu\text{A}$  of  $I_{SET}$  current to the amplifier and mirror circuit. Care should be taken to limit the  $I_{SET}$  current below  $200 \ \mu\text{A}$  to avoid saturating the internal amplifier circuit.
- $R_{LIMIT}$  in conjunction with the  $0.5 \times I_{SET}$  current produces a voltage on the  $ILIMIT$  pin which is proportional to the load current flowing in  $R_{SNS}$ . For details on setting the current limit, see [Current Limit Setting using  \$R\_{LIMIT}\$](#) .
- $R_{IMON}$  in conjunction with the  $0.5 \times I_{SET}$  current produces a voltage on the  $IMON$  pin which is proportional to the load current flowing in  $R_{SNS}$ . For details on setting the current limit. see [Cable Compensation](#).

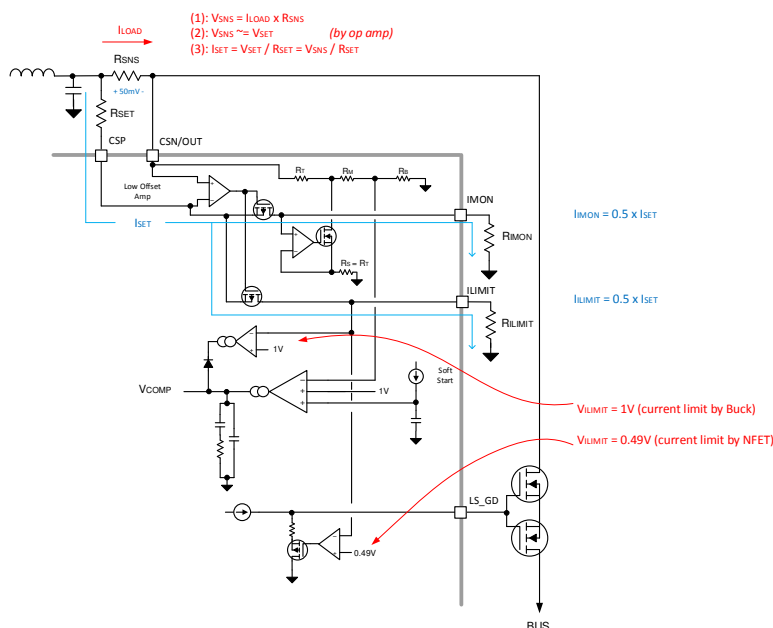

**图 10-15. Current Limit and Cable Compensation Circuit**

### 10.3.10 Overcurrent and Short Circuit Protection

For maximum versatility, TPS2583x-Q1 includes both a precision, programmable current limit and cycle-by-cycle current limit to protect the USB port from extreme overload conditions. In most applications the  $R_{LIMIT}$  resistor in conjunction with the selection of  $R_{SNS}$  and  $R_{SET}$  will determine the overload threshold. The cycle-by-cycle current limit will serve as a backup means of protection in the event  $R_{LIMIT}$  is shorted to ground disabling the programmable current limit function.

In some application, the setting of TPS2583x-Q1 over-current need meet MFi requirement. For more details please refer to [How to Pass MFi Overcurrent Protection Test With USB Charger and Switch Device Application Report](#).

#### 10.3.10.1 Current Limit Setting using $R_{LIMIT}$

Refer to [图 10-15](#). The TPS2583x-Q1 can establish current limit by two methods.

- Using external a single or back-to-back N-Channel MOFETs between  $CSN/OUT$  and  $BUS$ : A voltage of  $0.49 \text{ V}$  on the  $ILIMIT$  pin initiates current limiting using the external MOSFET by decreasing the  $LS\_GD$  voltage causing the FET to operate in the saturation region. To protect the MOSFETs from damage a hiccup timer limits the duty cycle to prevent thermal runaway. Refer to the [Switching Characteristics](#) for MOSFET hiccup timing.

- Buck average current limit: No MOSFET, CSN/OUT connected to BUS. For TPS25831-Q1, the LS\_GD pin can be left floating. For TPS25830-Q1, the LS\_GD pin must be pulled up through a 2.2-kΩ resistor. In this configuration, a voltage of 1 V across R<sub>ILIMIT</sub> on the ILIMIT pin initiates average current limiting of the buck regulator.

The two level current limit is described below:

- With external MOSFET [图 10-16](#), [图 10-17](#):
  - Isolating a fault on the USB port from other loads connected to the CSP output of the TPS2583x-Q1. In some applications, it may be useful to power additional circuitry (example USB HUB) from the output of the TPS2583x-Q1 and maintain operation of these circuits in the event of a short circuit downstream of the BUS pin. To prevent triggering the MOSFET current limit below the programmed ILIMIT threshold, external circuits must be supplied after the inductor and before the current sense resistor, R<sub>SNS</sub>.
  - After R<sub>SNS</sub> and R<sub>SET</sub> are determined and the full load I<sub>SET</sub> current is known, the resistor value R<sub>ILIMIT</sub> can be determined by:

$$R_{ILIMIT} = \frac{0.49 \times R_{SET}}{0.5 \times (I_{LIMIT} \times R_{SNS} + 0.0007)} \quad (6)$$

- In most case, the recommended voltage across R<sub>SNS</sub> under current limit should be approximately 50 mV as a compromise between accuracy and power dissipation. While in some application, R<sub>ILIMIT</sub> is the only resistor that can be changed to achieve different current limit. Typical R<sub>ILIMIT</sub> resistors value are listed in [表 10-2](#) given the condition R<sub>SNS</sub>= 15 mΩ and R<sub>SET</sub>= 300 Ω

**表 10-2. Setting the Current Limit with R<sub>ILIMIT</sub>**

Current-Limit Threshold (mA)	R <sub>ILIMIT</sub> (kΩ)	
	With External MOSFET	Buck Average
700	26.1	53.6
1500	12.7	26.1
1700	11.3	22.6
2700	7.15	14.7
3000	6.49	13
3400	5.62	11.5
3800	5.11	10.5

- Buck Average Current Limit, [图 10-18](#), [图 10-19](#):
  1. CSN/OUT connected directly to BUS. For TPS25831-Q1, LS\_GD pin can be floating. For TPS25830-Q1, LS\_GD pin must be pulled up through a 2.2-kΩ resistor. The TPS2583x-Q1 can operate as a stand-alone USB charging port. In this configuration, the internal buck regulator operates with average current limiting as programmed by the ILIMIT pin, potentially producing less heat compared to N-channel MOSFET current limiting
  2. After R<sub>SNS</sub> and R<sub>SET</sub> are determined and the full load I<sub>SET</sub> current is known, the resistor value R<sub>ILIMIT</sub> can be determined by:

$$R_{ILIMIT} = \frac{1 \times R_{SET}}{0.5 \times (I_{LIMIT} \times R_{SNS} + 0.0007)} \quad (7)$$

3. Typical R<sub>ILIMIT</sub> resistors value are listed in [表 10-2](#) given the condition R<sub>SNS</sub>= 15 mΩ and R<sub>SET</sub>= 300 Ω

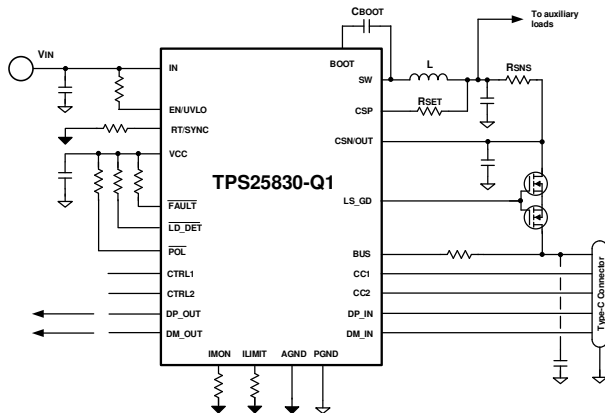
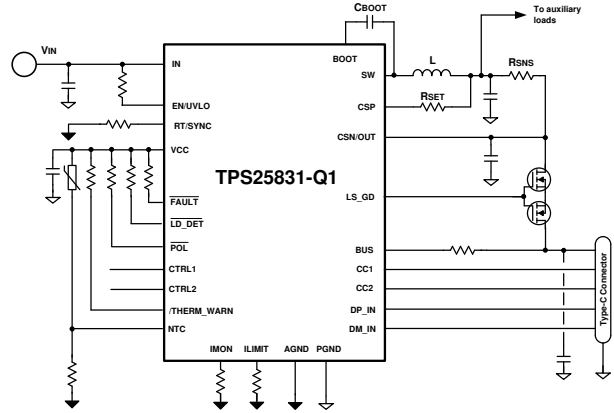
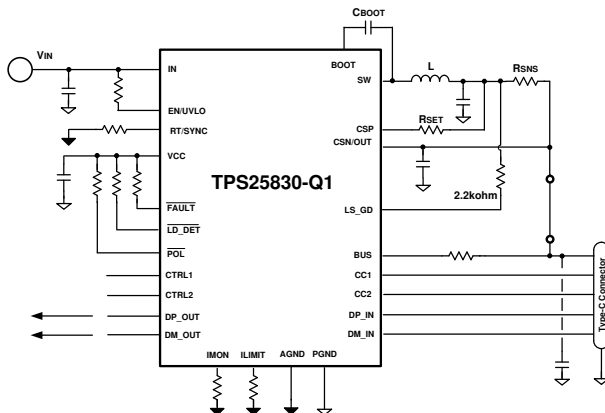
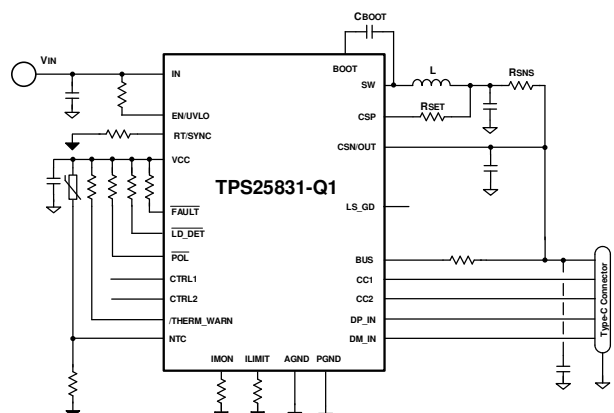
**图 10-16. TPS25830-Q1 Current Limit with External MOSFET**

**图 10-17. TPS25831-Q1 Current Limit with External MOSFET**

**图 10-18. TPS25830-Q1 Buck Average Current Limit**

**图 10-19. TPS25831-Q1 Buck Average Current Limit**

### 10.3.10.2 Buck Average Current Limit Design Example

To start the procedure, the  $I_{LOAD(MAX)}$ ,  $R_{SNS}$ ,  $R_{SET}$ , must to be known.

1. Determine  $I_{LIMIT}$ , usually chose  $I_{LIMIT} = I_{LOAD(MAX)} / (1 - 10\%)$ .
2. Determine  $R_{SNS}$  to achieve 50 mV at current limit. For 3-A Type-C load current, choose  $I_{LIMIT} = 3.3A$ .  $R_{SNS} = (0.05 V / 3.3 A) = 15 m\Omega$ .
3. Choose  $R_{SET} = 300 \Omega$
4. According to 方程式 7,  $R_{LIMIT} = 300 / (0.5 \times (3.3 \times 0.015 + 0.0007)) = 11.95 k\Omega$ .
5. Choose standard 11.8 k $\Omega$ .

### 10.3.10.3 External MOSFET Gate Drivers

The TPS2583x-Q1 has integrated NFET gate drivers, and can support current limit with external NFET. Refer to 图 10-16.

The LS\_GD pin of TPS2583x-Q1 can source 3 uA (typical) current to enhance the external MOSFET. A 6.2-V clamp between LS\_GD and CSN/OUT pin limits the gate-to-source voltage. During DCDC start up, the LS\_GD gate drivers begin to source current after  $V_{CSN/OUT}$  reach 3 V. If the  $V_{CSN/OUT} > 7.5 V$  or  $V_{BUS} > 7 V$  under overvoltage condition, the LS\_GD will turn off immediately with 35 uA (typical) sink current.

If load current above NFET current limit threshold, LS\_GD will also turn off the NFET after 2 ms (Typical) and enter hiccup mode to protect NFET from thermal issue. Refer to Figure 11-26 for application waveform.

In real application, if  $V_{BUS}$  short to  $V_{BAT}$  function is needed, 20-V back-to-back NFET is suggested in circuit design.

### 10.3.10.4 Cycle-by-Cycle Buck Current Limit

The buck regulator cycle-by-cycle current limit on both the peak and valley of the inductor current. Hiccup mode will be activated if a fault condition persists to prevent over-heating.

High-side MOSFET overcurrent protection is implemented by the nature of the Peak Current Mode control. The HS switch current is sensed when the HS is turned on after a set blanking time. The HS switch current is compared to the output of the Error Amplifier (EA) minus slope compensation every switching cycle. Refer to [Functional Block Diagram](#) for more details. The peak current of HS switch is limited by a clamped maximum peak current threshold  $I_{HS\_LIMIT}$  which is constant. So the peak current limit of the high-side switch is not affected by the slope compensation and remains constant over the full duty cycle range.

The current going through LS MOSFET is also sensed and monitored. When the LS switch turns on, the inductor current begins to ramp down. The LS switch will not be turned OFF at the end of a switching cycle if its current is above the LS current limit  $I_{LS\_LIMIT}$ . The LS switch will be kept ON so that inductor current keeps ramping down, until the inductor current ramps below the LS current limit  $I_{LS\_LIMIT}$ . Then the LS switch will be turned OFF and the HS switch will be turned on after a dead time. This is somewhat different than the more typical peak current limit, and results in [Equation 8](#) for the maximum load current.

$$I_{OUT\_MAX} = 0.5 \times (I_{LS\_LIMIT} + I_{HS\_LIMIT}) \quad (8)$$

If  $V_{CSN/OUT} < 2\text{-V}$  typical due to a short circuit for 128 consecutive cycles, hiccup current protection mode will be activated. In hiccup mode, the regulator will be shut down and kept off for 118 ms typically, then TPS2583x-Q1 go through a normal re-start with soft start again. If the short-circuit condition remains, hiccup will repeat until the fault condition is removed. Hiccup mode reduces power dissipation under severe overcurrent conditions, prevents over-heating and potential damage to the device and serves as a backup to the programmable current limit see the [Current Limit Setting using  \$R\_{LIMIT}\$](#)  section. Once the output short is removed, the hiccup delay is passed, the output voltage recovers normally as shown in [图 11-23](#).

### 10.3.11 Overvoltage, IEC and Short to Battery Protection

The TPS2583x-Q1 integrates OVP and short to battery protection on VBUS, CC1, CC2, DM\_IN and DP\_IN pins. These pins can withstand voltage up to 18 V, and can protect upstream processor or Hub data line when overvoltage or short to battery condition occurs. Refer to [图 9-5](#) for short to battery test setup.

For more detailed TPS2583x-Q1 Short to Battery consideration and test report, please refer to the [TPS2583x-Q1 and TPS2584x-Q1 Short-to- Battery Application Application Report](#).

The TPS2583x-Q1 also integrates IEC ESD cell on CC1, CC2, DP\_IN and DM\_IN pins.

#### 10.3.11.1 $V_{BUS}$ and $V_{CSN/OUT}$ Overvoltage Protection

The TPS2583x-Q1 integrates overvoltage protection on both BUS and CSN/OUT pin, to meet different application requirement.

BUS pin can withstand up to 18 V, and the OVP threshold is 7-V typical. Once overvoltage is detected on BUS pin, the LS\_GD will turn off immediately, also  $\overline{\text{FAULT}}$  asserts after 8-ms deglitch time. Once the excessive voltage is removed, the LS\_GD will turn on again and  $\overline{\text{FAULT}}$  deasserts.

CSN/OUT pin can withstand up to 20 V, and the OVP threshold is 7.5-V typical. Once overvoltage is detected on CSN/OUT pin, the buck converter will stop regulation, also LS\_GD will turn off immediately. Once the excessive voltage is removed, the buck converter will resume and LS\_GD turn on again.

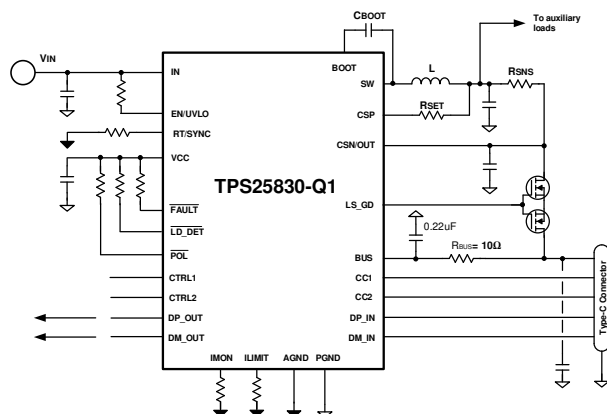
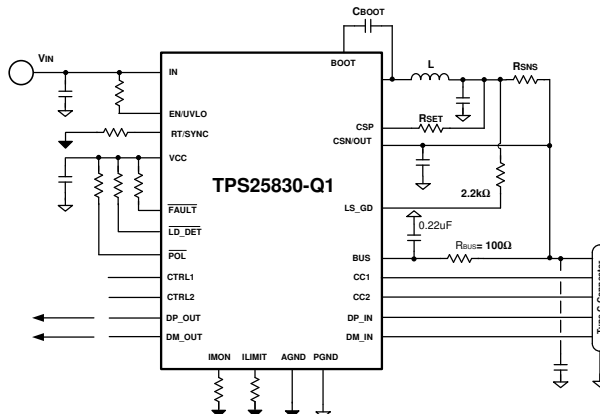
**图 10-20. Current Limit With External MOSFET**

**图 10-21. Buck Average Current Limit**

TPS2583x-Q1 is configured in external FET current limit mode as shown in [图 10-20](#). When short to battery occurs on BUS\_Connector, the external MOSFET will be turn off immediately after BUS pin detect overvoltage. The  $\overline{\text{FAULT}}$  signal will assert after 8-ms deglitch time, see [图 11-31](#). With Back-to-back FET, the TPS2583x-Q1 can withstand short to battery event even when  $V_{in}$  is off. A 10- $\Omega$  0805 resistor is recommended between BUS pin and BUS\_Connector.

TPS2583x-Q1 is configured in buck average current limit mode as shown in [图 10-21](#). When short to battery occurs on BUS\_Connector, the buck regulator will stop switching after CSN/OUT pin detect overvoltage. The  $\overline{\text{FAULT}}$  signal will also assert after 8-ms deglitch time. A 100- $\Omega$  0805 resistor is recommended between BUS pin and BUS\_Connector in buck average current limit mode.

### 10.3.11.2 DP\_IN and DM\_IN Protection

DP\_IN and DM\_IN protection consists of IEC ESD and overvoltage protection.

The DP\_IN and DM\_IN pins integrate an IEC ESD cell to provide ESD protection up to  $\pm 15$ -kV air discharge and  $\pm 8$ -kV contact discharge per IEC 61000-4-2 (See the [ESD Ratings](#) section for test conditions). The IEC ESD performance of the TPS2583x-Q1 device depends on the capacitance connected from BUS pin to GND. A 0.22- $\mu\text{F}$  capacitor placed close to the BUS pin is recommended.

The ESD stress seen at DP\_IN and DM\_IN is impacted by many external factors like the parasitic resistance and inductance between ESD test points and the DP\_IN and DM\_IN pins. For air discharge, the temperature and humidity of the environment can cause some difference, so the IEC performance should always be verified in the end-application circuit.

Overvoltage protection (OVP) is provided for short-to- $V_{BUS}$  or short-to-battery conditions in the vehicle harness, preventing damage to the upstream USB transceiver or hub. When the voltage on DP\_IN or DM\_IN exceeds 3.9 V (typical), the TPS2583x-Q1 device immediately turn off DP/DM switch, and responds to block the high-voltage reverse connection to DP\_OUT and DM\_OUT.  $\overline{\text{FAULT}}$  signal will assert after 8ms deglitch time, see [Figure 11-35](#).

For DP\_IN and DM\_IN, when OVP is triggered, the device turns on an internal discharge path with 416-k $\Omega$  resistance to ground. On removal of the overvoltage condition, the pin automatically turns off this discharge path and returns to normal operation by turning on the previously affected analog switch.

### 10.3.11.3 CC IEC and OVP Protection

CCx protection consists of IEC ESD and overvoltage protection.

The CC pins integrate an IEC ESD cell to provide ESD protection up to  $\pm 1$ - kV air discharge and  $\pm 8$ -kV contact discharge per IEC 61000-4-2 (See the [ESD Ratings](#) section for test conditions). An additional 0.22- $\mu\text{F}$  capacitor placed close to the CC pin is recommended in real application.

Overvoltage protection (OVP) is provided for short-to- $V_{BUS}$  or short-to-battery conditions in the vehicle harness. When the voltage on CC1 or CC2 exceeds 6.1 V (typical), the TPS2583x-Q1 device immediately shut off CC line. FAULT signal will assert after 8-ms deglitch time. See Figure 11-33.

For CC1 and CC2, when OVP is triggered, the device turns on an internal discharge path with 55-k $\Omega$  resistance to ground. On removal of the overvoltage condition, the pin automatically turns off this discharge path and returns to normal operation.

### 10.3.12 Cable Compensation

When a load draws current through a long or thin wire, there is an IR drop that reduces the voltage delivered to the load. Cable droop compensation linearly increases the voltage at the CSN/OUT pin of TPS2583x-Q1 as load current increases with the objective of maintaining  $V_{BUS\_CON}$  (the bus voltage at the USB connector) at 5 V, regardless of load conditions. Most portable devices charge at maximum current when 5 V is present at the USB connector. Figure 10-22 provides an example of resistor drops encountered when designing an automotive USB system with a remote USB connector location.



图 10-22. Automotive USB Resistances

The TPS2583x-Q1 detects the load current and increases the voltage at the CSN/OUT pin to compensate the IR drop in the charging path according to the gain set by the  $R_{SNS}$ ,  $R_{SET}$ , and  $R_{IMON}$  resistors as described in  $R_{SNS}$ ,  $R_{SET}$ ,  $R_{LIMIT}$ , and  $R_{IMON}$ .

The amount of cable droop compensation required can be estimated by the following equation  $\Delta V_{OUT} = (R_{SNS} + R_{DSON\_NFET} + R_{WIRE}) \times I_{BUS}$ .  $R_{IMON}$  is then chosen by  $R_{IMON} = (\Delta V_{OUT} \times R_{SET} \times 2) / (I_{BUS} \times R_{SNS})$ , where  $\Delta V_{OUT}$  is the desired cable droop compensation voltage at full load.

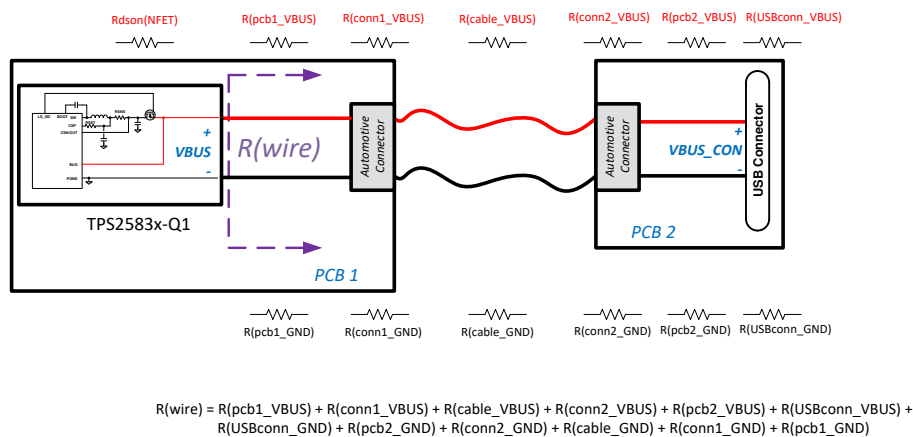

图 10-23. Voltage Drop

Per  $R_{SNS}$ ,  $R_{SET}$ ,  $R_{LIMIT}$ , and  $R_{IMON}$ , in most cases, the recommended voltage across  $R_{SNS}$  should be 50 mV. In type-C application, typical  $R_{IMON}$  resistors value are listed in 表 10-3 given the condition full load current = 3 A,  $R_{SNS} = 15\text{ m}\Omega$  and  $R_{SET} = 300\ \Omega$ .

表 10-3. Setting the Cable Compensation Voltage with  $R_{IMON}$

Cable Compensation Voltage at 3-A Full Load (V)	$R_{IMON}$ (k $\Omega$ )
0.3	4.02
0.6	8.06
0.9	12.1
1.2	16.2
1.5	20

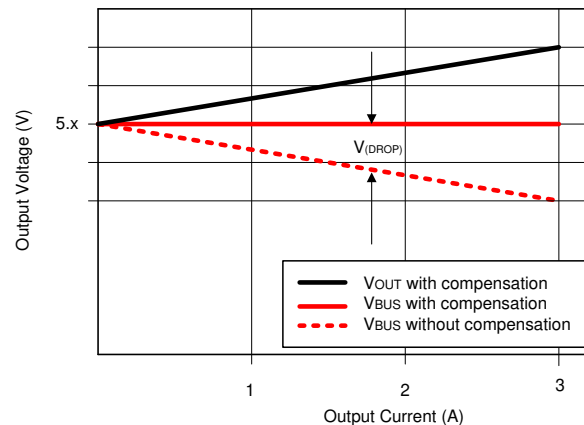
Pls be noted that the max cable compensation voltage in TPS2583x-Q1 is 1.5 V.

### 10.3.12.1 Cable Compensation Design Example

To start the procedure, the  $R_{SNS}$ ,  $R_{DSON\_NFET}$  and wire resistance  $R_{WIRE}$ , must to be known.

- Determine  $R_{SNS}$  to achieve 50 mV at full current. For 3.3 A (3-A Type-C load current plus at approximately 10% for overcurrent threshold).  $R_{SNS} = (0.05\text{ V} / 3.3\text{ A}) = 15\text{ m}\Omega$ .
- $R_{DSON\_NFET} = 50\text{ m}\Omega$
- $R_{WIRE} = 200\text{ m}\Omega$
- $\Delta V_{OUT} = (R_{SNS} + R_{DSON\_NFET} + R_{WIRE}) \times I_{BUS} = (0.015 + 0.05 + 0.2) \times 3 = 0.795\text{ V}$
- Choose  $R_{SET} = 300\ \Omega$
- $R_{IMON} = (\Delta V_{OUT} \times R_{SET} \times 2) / (I_{BUS} \times R_{SNS}) = (0.795 \times 300 \times 2) / (3 \times 0.015) = 10.6\text{ k}\Omega$

### 10.3.13 USB Port Control

The TPS25830-Q1 and TPS25831-Q1 include DP\_IN, DM\_IN, CC1 and CC2 pins for automatic or host facilitated USB port power management of either a Type-A or Type-C downstream facing connector. See the [Device Functional Modes](#) section for details on configuring the TPS2583x-Q1.

### 10.3.14 FAULT Response

The device features an active-low, open-drain fault output. Connect a 100-k $\Omega$  pullup resistor from  $\overline{\text{FAULT}}$  to VCC or other suitable I/O voltage.  $\overline{\text{FAULT}}$  can be left open or tied to GND when not used.

表 10-4 summarizes the conditions that generate a fault and actions taken by the device.

表 10-4. Fault and Warning Conditions

EVENT	CONDITION	ACTION
Overcurrent on OUT	NFET or Buck average current limit implemented per <a href="#">Current Limit Setting using <math>R_{LIMIT}</math></a> . $I_{CSN/OUT} > \text{programmed } I_{SNS}$ .	The device regulates current at $I_{SNS}$ either by external NFET or by the buck regulator control loop. When current limiting by external NFET, there is NO fault indicator assertion under minor overload conditions. When current limiting by buck average current, there is NO fault indicator assertion under minor overload conditions. Hard shorts during average buck current limiting may trigger buck hiccup operation. The $\overline{\text{FAULT}}$ indicator asserts immediately after $N_{OC}$ cycles in and persists for $T_{OC}$ as specified in the <a href="#">Cycle-by-Cycle Buck Current Limit</a> section.
Overvoltage on BUS	$V_{BUS} > V_{BUS\_OV}$	The device turns on the BUS discharge path in the event of an overvoltage conditions, and turn off the LS_GD immediately. The $\overline{\text{FAULT}}$ indicator asserts and de-asserts with a 8-ms deglitch.
Overvoltage on the data lines	DP_IN or DM_IN $> V_{Dx\_IN\_OV}$	The device immediately shuts off the USB data switches. The $\overline{\text{FAULT}}$ indicator asserts and de-asserts with a 8-ms deglitch.
Overvoltage on CC lines	CC1 or CC2 $> V_{CCx\_OV}$	The device immediately shuts off the CC lines. The $\overline{\text{FAULT}}$ indicator asserts and de-asserts with a 8-ms deglitch.

**表 10-4. Fault and Warning Conditions (continued)**

EVENT	CONDITION	ACTION
Overcurrent on CC lines when supplying VCONN	$I_{LOAD\_CCn} > I_{OS\_CCn}$	The FAULT indicator asserts and de-asserts with a 8-ms deglitch. The FAULT indicator remains asserted during the VCONN overload condition and the VCONN path is not disabled.
TPS25831-Q1 External overtemperature detection (NTC)	$V_{NTC} \geq V_{WARN\_HIGH}$	Thermal warning flag THERM_WARN asserts immediately. Also the type-C advertise current will change to 1.5 A if operate with 3 A originally. The FAULT flag is not asserted for this condition, but will assert for conditions stated in this table.
TPS25831-Q1 External overtemperature detection (NTC)	$V_{NTC} \geq V_{SD\_HIGH}$	The device immediately shuts off the buck regulator, opens the USB data switches, while simultaneously pulling LS_GD and BUS low. The THERM_WARN indicator remains asserted.

### 10.3.15 USB Specification Overview

Universal Serial Bus specifications provide critical physical and electrical requirements to electronics manufacturers of USB capable equipment. Adherence to these specifications during product development coupled with standardized compliance testing assures very high degrees of interoperability amongst USB products in the market. Since its inception in the mid 1990s, USB has undergone a number of revisions to enhance utility and extend functionality. For the most up to date standards, please consult the USB Implementers Forum (USB-IF).

All USB ports are capable of providing a 5-V output making them a convenient power source for operating and charging portable devices. USB specification documents outline specific power requirements to ensure interoperability. In general, a USB 2.0 port host port is required to provide up to 500 mA; a USB 3.0 or USB 3.1 port is required to provide up to 900 mA; ports adhering to the USB Battery Charging 1.2 Specification provide up to 1500 mA; and newer Type-C ports can provide up to 3000 mA. Though USB standards governing power requirements exist, some manufacturers of popular portable devices created their own proprietary mechanisms to extend allowed available current beyond the 1500-mA maximum per BC 1.2. While not officially part of the standards maintained by the USB-IF, these proprietary mechanisms are recognized and implemented by manufacturers of USB charging ports.

The TPS2583x-Q1 device supports five of the most-common USB-charging schemes found in popular hand-held media and cellular devices.

- USB Type-C (1.5 A and 3 A advertisement)
- USB Battery Charging Specification BC1.2
- Chinese Telecommunications Industry Standard YD/T 1591-2009
- Divider 3 mode
- 1.2-V mode

The BC1.2 specification includes three different port types:

- Standard downstream port (SDP)
- Charging downstream port (CDP)
- Dedicated charging port (DCP)

BC1.2 defines a charging port as a downstream-facing USB port that provides power for charging portable equipment. Under this definition, CDP and DCP are defined as charging ports.

表 10-5 lists the difference between these port types.

**表 10-5. USB Operating Modes Table**

PORT TYPE	SUPPORTS USB2.0 COMMUNICATION	MAXIMUM ALLOWABLE CURRENT DRAWN BY PORTABLE EQUIPMENT (A)
SDP (USB 2.0)	YES	0.5
SDP (USB 3.0 and 3.1)	YES	0.9

表 10-5. USB Operating Modes Table (continued)

PORT TYPE	SUPPORTS USB2.0 COMMUNICATION	MAXIMUM ALLOWABLE CURRENT DRAWN BY PORTABLE EQUIPMENT (A)
CDP	YES	1.5
DCP	NO	1.5
TYPE-C	YES	3.0

### 10.3.16 USB Type-C® Basics

For a detailed description of the Type-C specifications refer to the USB-IF website to download the latest information. Understanding the basic concepts of the USB Type-C specification will aid in understanding the operation of the TPS2583x-Q1 (a DFP device).

USB Type-C removes the need for different plug and receptacle types for host and device functionality. The Type-C receptacle replaces both Type-A and Type-B receptacle since the Type-C cable is plug-able in either direction between host and device. A host-to-device logical relationship is maintained via the configuration channel (CC). Optionally hosts and devices can be either providers or consumers of power when USB Power Delivery (PD) communication is used to swap roles.

All USB Type-C ports operate in one of below three data modes:

- Host mode: the port can only be host (provider of power)
- Device mode: the port can only be device (consumer of power)
- Dual-Role mode: the port can be either host or device

Port types:

- DFP (Downstream Facing Port): Host
- UFP (Upstream Facing Port): Device
- DRP (Dual-Role Port): Host or Device

Valid DFP-to-UFP connections:

- 表 10-6 describes valid DFP-to-UFP connections
- Host to Host or Device to Device have no functions

表 10-6. DFP-to-UFP Connections

	HOST-MODE PORT	DEVICE-MODE PORT	DUAL-ROLE PORT
Host-Mode Port	No Function	Works	Works
Device-Mode Port	Works	No Function	Works
Dual-Role Port	Works	Works	Works <sup>(1)</sup>

(1) This may be automatic or manually driven.

#### 10.3.16.1 Configuration Channel

The function of the configuration channel is to detect connections and configure the interface across the USB Type-C cables and connectors.

Functionally the Configuration Channel (CC) is used to serve the following purposes:

- Detect connect to the USB ports
- Resolve cable orientation and twist connections to establish USB data bus routing
- Establish DFP and UFP roles between two connected ports
- Discover and configure power: USB Type-C current modes or USB Power Delivery
- Discovery and configure optional Alternate and Accessory modes
- Enhance flexibility and ease of use

Typical flow of DFP to UFP configuration is shown in 图 10-24:



图 10-24. Flow of DFP to UFP Configuration

### 10.3.16.2 Detecting a Connection

DFPs and DRPs fulfill the role of detecting a valid connection over USB Type-C. 图 10-25 shows a DFP to UFP connection made with Type C cable. As shown in 图 10-25, the detection concept is based on being able to detect terminations in the product which has been attached. A pull-up and pull-down termination model is used. A pull-up termination can be replaced by a current source. TPS2583x-Q1 devices use current sources in lieu of  $R_P$  as allowed by the Type-C specification.

- In the DFP-UFP connection the DFP monitors both CC pins for a voltage lower than the unterminated voltage.
- An UFP advertises  $R_d$  on both its CC pins (CC1 and CC2).
- A powered cable advertises  $R_a$  on only one of CC pins of the plug.  $R_a$  is used to inform the source to apply VCONN.
- An analog audio device advertises  $R_a$  on both CC pins of the plug, which identifies it as an analog audio device. VCONN is not applied on either CC pin in this case.

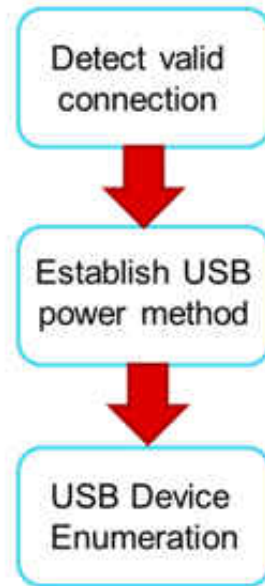

图 10-25. DFP-UFP Connection

### 10.3.16.3 Configuration Channel Pins CC1 and CC2

The TPS2583x-Q1 has two pins, CC1 and CC2 that serve to detect an attachment to the port and resolve cable orientation. These pins are also used to establish current broadcast to a valid UFP and configure VCONN.

表 10-7 lists TPS2583x-Q1 response to various attachments to its port.

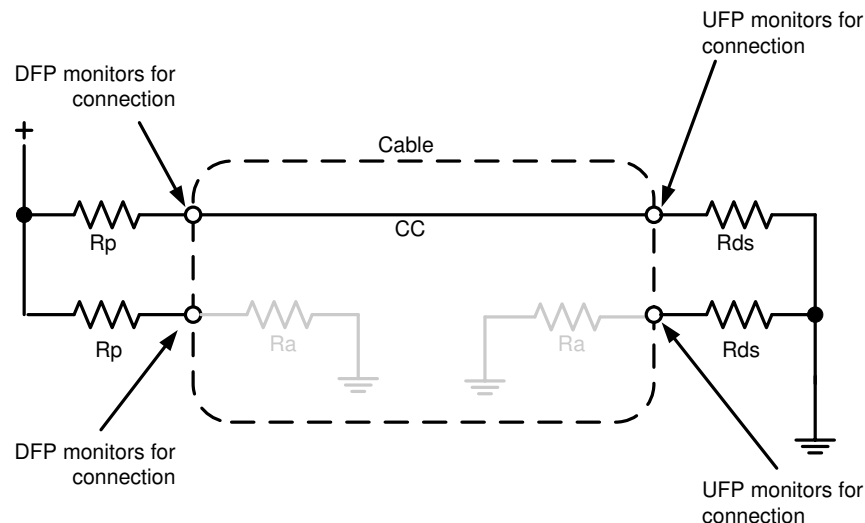
表 10-7. TPS2583x-Q1 Response

TPS2583x-Q1 TYPE-C PORT	CC1	CC2	TPS2583x-Q1 RESPONSE <sup>(1)</sup>				
			BUCK REGULATOR	LS_GD	V <sub>CONN</sub> On CC1 or CC2 <sup>(2)</sup>	POL	LD_DET
Nothing Attached	OPEN	OPEN	OFF	OFF	NO	Hi-Z	Hi-Z
UFP Connected	Rd	OPEN	ON	ON	NO	Hi-Z	LOW
UFP Connected	OPEN	Rd	ON	ON	NO	LOW	LOW
Powered Cable/No UFP Connected	OPEN	Ra	OFF	OFF	NO	Hi-Z	Hi-Z
Powered Cable/No UFP Connected	Ra	OPEN	OFF	OFF	NO	Hi-Z	Hi-Z
Powered Cable/UFP Connected	Rd	Ra	ON	ON	CC2	Hi-Z	LOW
Powered Cable/UFP Connected	Ra	Rd	ON	ON	CC1	LOW	LOW
Debug Accessory Connected <sup>(3)</sup>	Rd	Rd	OFF	OFF	NO	Hi-Z	Hi-Z
Audio Adapter Accessory Connected <sup>(3)</sup>	Ra	Ra	OFF	OFF	NO	Hi-Z	Hi-Z

(1) POL and LD\_DET are open drain outputs; pull high with 100 kΩ to VCC when used. Tie to GND or leave open when not used.

(2) To supply V<sub>CONN</sub> a 5-V external LDO with at least 500-mA output, current should be connected to the V<sub>CC</sub> pin.

(3) The TPS2583x-Q1 does not support debug mode or audio mode.

### 10.3.16.4 Current Capability Advertisement and VCONN Overload Protection

The TPS2583x-Q1 supports all three Type-C current advertisements as defined by the USB Type-C standard. Current broadcast to a connected UFP is controlled by the CTRL1 and CTRL2 pins. For each broadcast level the device protects itself from a UFP that draws current in excess of the port's USB Type-C Current advertisement by setting the current limit as shown in 表 10-8.

表 10-8. USB Type-C<sup>®</sup> Current Advertisement

DEVICE	CTRL1	CTRL2	CC CAPABILITY BROADCAST	MODE	SUPPORT USB 2.0 COMMUNICATION	CURRENT LIMIT (typ)
'830-Q1	0	0	RESERVED, DO NOT USE			
	0	1	RESERVED, DO NOT USE			
	1	0	1.5 A	SDP	YES: DP_IN to DP_OUT and DM_IN to DM_OUT	BY R <sub>SNS</sub> , R <sub>SET</sub> , R <sub>LIMIT</sub>
	1	1	3 A	CDP	YES: DP_IN to DP_OUT and DM_IN to DM_OUT	
'831-Q1	0	0	RESERVED, DO NOT USE			
	0	1	3 A	DCP auto	NOT SUPPORT	BY R <sub>SNS</sub> , R <sub>SET</sub> , R <sub>LIMIT</sub>
	1	0	1.5 A	SDP	Stub Connection Only	
	1	1	3 A	CDP	Stub Connection Only	

Under overload conditions, a precision current-limit circuit limits the VCONN output current. When a VCONN overload condition is present, the TPS2583x-Q1 maintains a constant output current, with the output voltage determined by (I<sub>OS\_CCn</sub> × R<sub>LOAD</sub>). VCONN functionality is supported only with an external 5-V supply connected to VCC. Failure to connect an external supply may cause TPS2583x-Q1 V<sub>CC</sub> reset. The device turns off when the junction temperature exceeds the thermal shutdown threshold, T<sub>SD</sub> and remains off until the junction

temperature cools approximately 20°C and then restarts. The TPS2583x-Q1 current limit profile is shown in 图 10-26.



图 10-26. VCONN Current Limit Profile

### 10.3.16.5 Plug Polarity Detection

Reversible Type-C plug orientation is reported by the  $\overline{\text{POL}}$  pin when a UFP is connected. However when no UFP is attached,  $\overline{\text{POL}}$  remains de-asserted irrespective of cable plug orientation. 表 10-9 describes the  $\overline{\text{POL}}$  state based on which device CC pin detects  $V_{RD}$  from an attached UFP pull-down.

表 10-9. Plug Polarity Detection

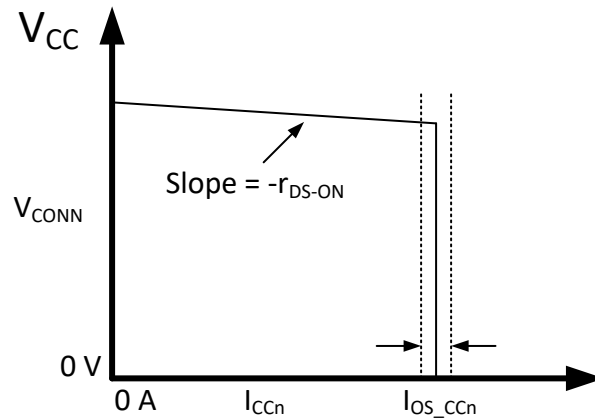
CC1	CC2	POL	STATE
Rd	Open	Hi-Z	UFP connected
Open	Rd	Asserted (pulled low)	UFP connected with reverse plug orientation

图 10-27 shows an example implementation that uses the  $\overline{\text{POL}}$  terminal to control the SEL terminal on the HD3SS3212. The HD3SS3212 provides switching on the differential channels between Port B and Port C to Port A depending on cable orientation.



must be connected to the TPS25831-Q1  $V_{CC}$  pin to achieve accurate results, see [图 10-28](#) and [图 10-29](#). When  $V_{NTC} = 0.5 \times V_{CC}$  (approximately 2.5-V typically), the TPS25831-Q1 performs two actions:

1. If operating with 3-A Type-C advertisement, the CC1 and CC2 pin automatically reduces advertisement to the 1.5-A level.
2. The `THERM_WARN` flag is asserted to provide an indication of the over-temperature condition. `FAULT` is NOT asserted at this time.



图 10-28. NTC Input Pin



图 10-29. TPS25831-Q1 Behavior When Trigger NTC Threshold

If the overtemperature condition persists causing  $V_{NTC} = V_{CC} \times 0.65$  (3.25-V typical), the TPS25831-Q1 turns off the buck regulator and pulls the LS\_GD pin low. The THERM\_WARN flag remains asserted; however, the FAULT pin is NOT asserted for this condition.

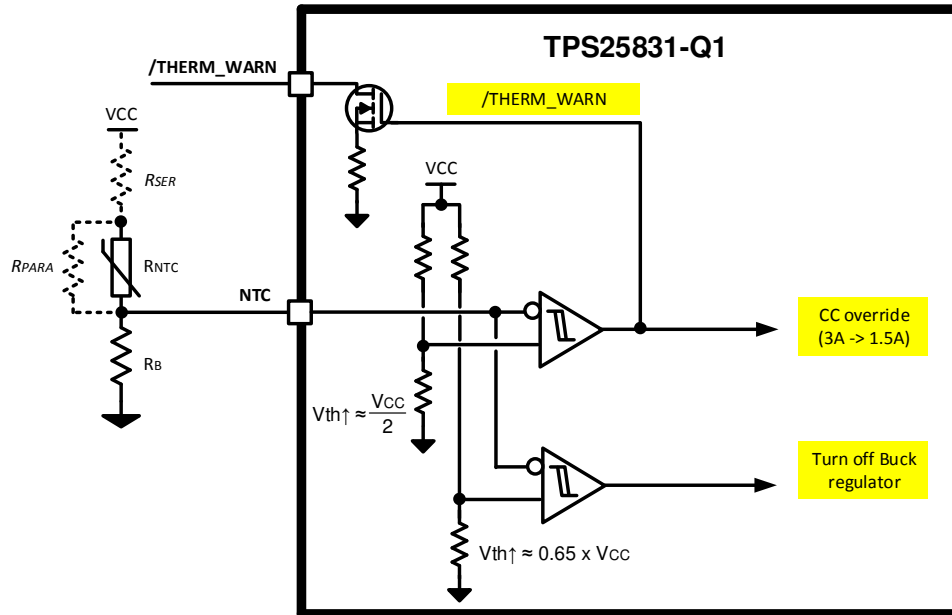
Tuning the  $V_{NTC}$  threshold levels of  $V_{WARN\_HIGH}$  and  $V_{SD\_HIGH}$  is achieved by adding  $R_{SER}$ ,  $R_{PARA}$ , or both  $R_{SER}$  and  $R_{PARA}$  in conjunction with  $R_{NTC}$ . 图 10-30 is an example illustrating how to set the THERM\_WARN threshold between 75°C and 90°C with a  $\Delta T$  between THERM\_WARN assertion and device shutdown of 17°C to 28°C. Consult the chosen NTC manufacturer's specification for the value of  $\beta$ . It may take some iteration to establish the desired warning and shutdown thresholds.

Below is NTC spec and resistor value used in 图 10-30 example.

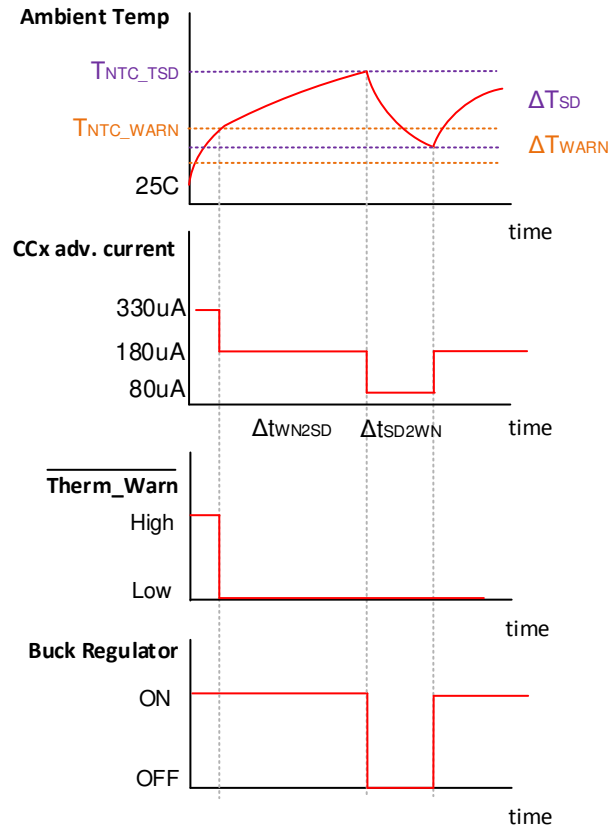
- $R_0 = 470 \text{ k}\Omega$ .  $\beta = 4750$ .  $R_{NTC} = R_0 \times \exp \beta \times (1/T - 1/T_0)$
- $R_{PARA} = 100 \text{ k}\Omega$ .
- $R_{SER} = 5 \text{ k}\Omega$ .
- $R_B = R_{NTC}(\text{at } T_{\text{THERM\_WARN}}) = 32 \text{ k}\Omega$

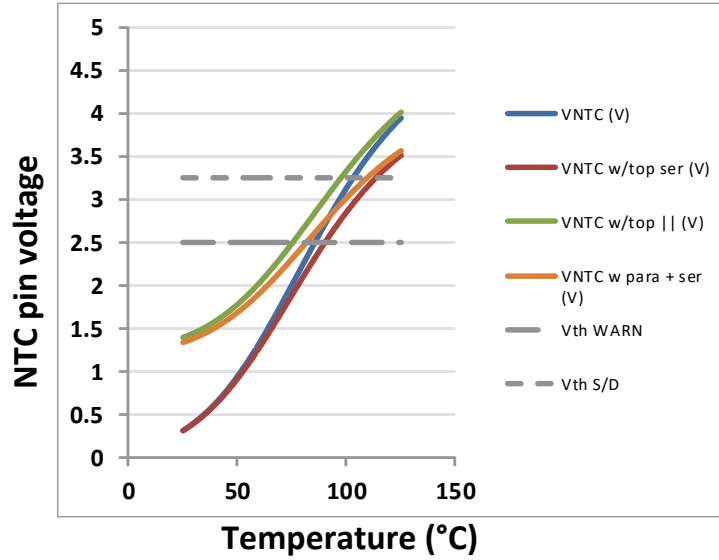

Example

Rising Thresholds	V (V)	T <sub>NTC</sub> (°C)	T <sub>NTC</sub>    (°C)	T <sub>NTC ser</sub> (°C)	T <sub>NTC</sub>    + ser (°C)	
Thermal Warning	=VCC * 0.5	2.5	85	75	90	81
NTC Shutdown	=VCC * 0.65	3.25	102	97	113	109
$\Delta$ (S/D - WARN)			17	22	23	28

图 10-30. V<sub>NTC</sub> Threshold Examples

The NTC resistor should be placed near the hottest point on the PCB. In most cases, this will be close to the SW node of the TPS25831-Q1, near the buck inductor, R<sub>SNS</sub> sense resistor and external MOSFETs (if used).



图 10-31. NTC Placement Example

## 10.4 Device Functional Modes

### 10.4.1 Shutdown Mode

The EN pin provides electrical ON and OFF control for the TPS2583x. When  $V_{EN}$  is below 1.2 V (typical), the device is in shutdown mode. The TPS2583x-Q1 also employs  $V_{IN}$  and  $V_{CC}$  undervoltage lock out protection. If  $V_{IN}$  or  $V_{CC}$  voltage is below their respective UVLO level, the regulator will be turned off.

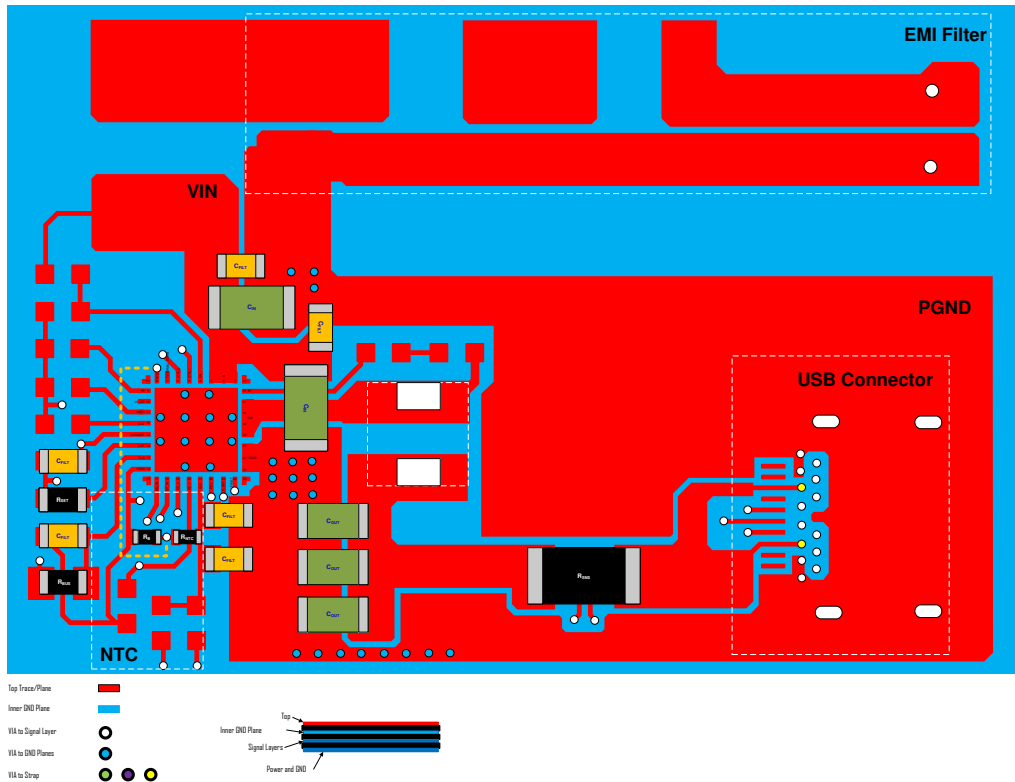
### 10.4.2 Standby Mode

If the EN pin is pulled above the EN threshold, and there is no active connection on the CC lines, TPS2583x-Q1 remains in a low-power state with the buck converter off until a valid UFP (sink) is detected with a valid  $R_D$  on either CC1 or CC2. This mode ensures the Type-C 0 V  $V_{BUS}$  requirement is met and saves system power when no device is connected.

### 10.4.3 Active Mode

The TPS2583x-Q1 is in Active Mode when  $V_{EN}$  is above the precision enable threshold,  $V_{IN}$  and  $V_{CC}$  are above their respective UVLO levels *and* a valid detection has been made on the CC lines. The simplest way to enable the TPS2583x-Q1 is to connect the EN pin to VIN pin. This connection allows self startup when the input voltage is in the operating range: 3.8 V to 36 V and a UFP detection is made. Refer to [VCC](#), [VCC\\_UVLO](#) and [Enable/UVLO and Start-up](#) for details on setting these operating levels.

In Active Mode, the TPS2583x-Q1 buck regulator operates with Forced Pulse Width Modulation (FPWM), also referred to as Forced Continuous Conduction Mode (FCCM). This operation ensures the buck regulator switching frequency remains constant under all load conditions. FPWM operation provides low output voltage ripple, tight output voltage regulation, and constant switching frequency. Built-in spread-spectrum modulation aids in distributing spectral energy across a narrow band around the switching frequency programmed by the RT/SYNC pin. Under light load conditions the inductor current is allowed to go negative. A negative current limit of  $I_{L\_NEG}$  is imposed to prevent damage to the regulator's low side FET. During operation the TPS2583x-Q1 will synchronize to any valid clock signal on the RT/SYNC input.

### 10.4.4 Device Truth Table (TT)

The device truth table (表 10-10) lists all valid combinations for the two control pins (CTRL1 and CTRL2). The TPS2583x-Q1 devices monitor the CTRL inputs and transitions to whichever charging mode it is commanded.

表 10-10. Truth Table

DEVICE	CTR L1	CTR L2	CURRENT LIMIT SETTING	USB MODES	BUCK REGULATOR	LS_GD	LD_DET (OUTPUT)	POL (OUTPUT)	FAULT (OUTPUT)	NTC (ANALOG INPUT)
TPS25830-Q1	0	0								RESERVED, DO NOT USE
	0	1								RESERVED, DO NOT USE
	1	0	See <a href="#">Current Limit Setting using <math>R_{LIMIT}</math></a>	Type-C (1.5 A) + SDP Mode	functional, see 表 10-7				Functional, see 表 10-4	n/a
	1	1		Type-C (3 A) + CDP Mode		n/a				
TPS25831-Q1	0	0								RESERVED, DO NOT USE
	0	1	<a href="#">Current Limit Setting using <math>R_{LIMIT}</math></a>	Type-C (3 A) + DCP Auto Mode	Functional, see 表 10-7			Functional, see 表 10-4	functional	
	1	0		Type-C (1.5 A) + SDP Mode		functional				
	1	1		Type-C (3 A) + CDP Mode		functional				

### 10.4.5 USB Port Operating Modes

#### 10.4.5.1 USB Type-C Mode

The TPS2583x-Q1 is a Type-C controller that supports all Type-C functions in a downstream facing port. It is also used to manage current advertisement and protection to a connected UFP and active cable. When VIN

exceeds the undervoltage lockout threshold, the device samples the EN pin. A high level on this pin enables the device and normal operation begins. Having successfully completed its start-up sequence, the device now actively monitors its CC1 and CC2 pins for attachment to a UFP. When a UFP is detected on either the CC1 or CC2 pin the buck regulator turn-ons after the required de-bounce time is met. If connected, the LS\_GD pin sources current into the external MOSFET allowing current to flow from CSN/OUT to BUS. If Ra is detected on the other CC pin (not connected to UFP), VCONN is applied to allow current to flow from VCC to the CC pin connected to Ra. For a complete listing of various device operational modes refer to [表 10-7](#).

The TPS2583x-Q1 always starts in Type-C mode, then transitions to DCP, CDP, or SDP as determined by the CTRL1 and CTRL2 pins and signaling by the connected portable device on the DP\_IN and DM\_IN pins.

#### **10.4.5.2 Standard Downstream Port (SDP) Mode — USB 2.0, USB 3.0, and USB 3.1**

A SDP is a traditional USB port that follows USB 2.0, USB 3.0 or USB 3.1 protocol. A USB 2.0 SDP supplies a minimum of 500 mA per port and supports USB 2.0 communications. A USB 3.x SDP supplies a minimum of 900 mA per port and supports USB 3.0 or USB 3.1 communications. For both types, the host controller must be active to allow charging.

#### **10.4.5.3 Charging Downstream Port (CDP) Mode**

A CDP is a USB port that follows USB BC1.2 and supplies a minimum of 1.5 A per port. A CDP provides power and meets the USB 2.0 requirements for device enumeration. USB-2.0 communication is supported, and the host controller must be active to allow charging. The difference between CDP and SDP is the host-charge handshaking logic that identifies this port as a CDP. A CDP is identifiable by a compliant BC1.2 client device and allows for additional current draw by the client device.

The CDP handshaking process occurs in two steps. During step one, the portable equipment outputs a nominal 0.6-V output on the DP line and reads the voltage input on the DM line. The portable device detects the connection to an SDP if the voltage is less than the nominal data-detect voltage of 0.3 V. The portable device detects the connection to a CDP if the DM voltage is greater than the nominal data detect voltage of 0.3 V and optionally less than 0.8 V.

The second step is necessary for portable equipment to determine whether the equipment is connected to a CDP or a DCP. The portable device outputs a nominal 0.6-V output on the DM line and reads the voltage input on the DP line. The portable device concludes the equipment is connected to a CDP if the data line being read remains less than the nominal data detects voltage of 0.3 V. The portable device concludes it is connected to a DCP if the data line being read is greater than the nominal data detect voltage of 0.3 V.

#### **10.4.5.4 Dedicated Charging Port (DCP) Mode (TPS25831-Q1 Only)**

A DCP only provides power and does not support data connection to an upstream port. As shown in the following sections, a DCP is identified by the electrical characteristics of the data lines. The TPS25831-Q1 only emulates one state, DCP-auto state. In the DCP-auto state, the device charge-detection state machine is activated to selectively implement charging schemes involved with the shorted, divider3 and 1.2-V modes. The shorted DCP mode complies with BC1.2 and Chinese Telecommunications Industry Standard YD/T 1591-2009, whereas the divider3 and 1.2-V modes are employed to charge devices that do not comply with the BC1.2 DCP standard.

##### **10.4.5.4.1 DCP BC1.2 and YD/T 1591-2009**

Both standards specify that the D+ and D – data lines must be connected together with a maximum series impedance of 200  $\Omega$ , as shown in [图 10-32](#).



图 10-32. DCP Supporting BC1.2 and YD/T 1591-2009

#### 10.4.5.4.2 DCP Divider-Charging Scheme

The device supports divider3, as shown in 图 10-33. In the Divider3 charging scheme the device applies 2.7 V and 2.7 V to D+ and D- data lines.

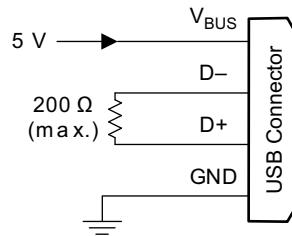

图 10-33. Divider 3 Mode

#### 10.4.5.4.3 DCP 1.2-V Charging Scheme

The DCP 1.2-V charging scheme is used by some hand-held devices to enable fast charging at 2 A. The TPS25831-Q1 device supports this scheme in DCP-auto state before the device enters BC1.2 shorted mode. To simulate this charging scheme, the D+ and D- lines are shorted and pulled up to 1.2 V for a fixed duration. Then the device moves to DCP shorted mode as defined in the BC1.2 specification and as shown in 图 10-34.

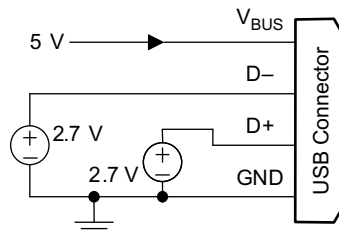

图 10-34. 1.2-V Mode

#### 10.4.5.5 DCP Auto Mode (TPS25831-Q1 Only)

The TPS25831-Q1 device integrates an auto-detect state machine that supports all DCP charging schemes. The auto-detect state machine starts in the Divider3 scheme. If a BC1.2 or YD/T 1591-2009 compliant device is attached, the TPS25831-Q1 device briefly transitions to the 1.2-V mode before entering BC1.2 DCP mode. The auto-detect state machine stays in the 1.2 V or DCP mode until the connected device releases the data line, in which case the auto-detect state machine goes back to the Divider3 scheme. When a Divider3-compliant device is attached, the TPS25831-Q1 device stays in the Divider3 state.

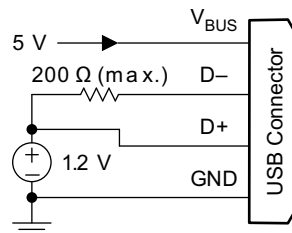

图 10-35. DCP Auto Mode

#### 10.4.6 High-Bandwidth Data-Line Switches (TPS25830-Q1 only)

The TPS25830-Q1 device passes the DP and DM data lines through the device to enable monitoring and handshaking while supporting the charging operation. A wide-bandwidth signal switch allows data to pass through the device without corrupting signal integrity. The data-line switches are turned on in any of the CDP, SDP modes. The EN/UVLO input must be at logic high and UFP must be entered for the data line switches to be enabled.

For more detailed USB2.0 data line consideration and eye diagram test report, please refer to the [How to improve USB2.0 Eye Diagram using long USB cable Application Report](#).

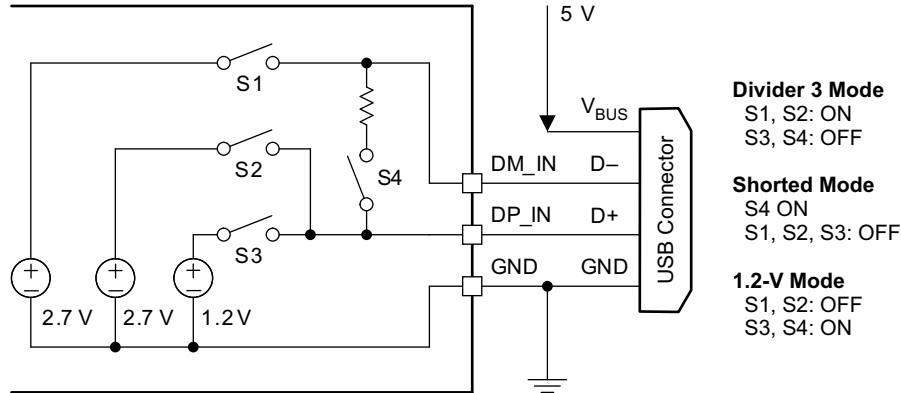
#### Note

- While in CDP mode, the data switches are ON, even during CDP handshaking.
- The data line switches are OFF if EN/UVLO is low.
- The data line switches are OFF during External FET current limit conditions.
- The data line switches are not turned off during VCONN current-limit conditions.
- The data line switches are OFF if UFP mode is not entered.
- The data switches are only for a USB-2.0 differential pair. In the case of a USB-3.0 or 3.1 host, the super-speed differential pairs must be routed directly to the USB connector without passing through the TPS25830-Q1 device.

## 11 Application and Implementation

### Note

以下应用部分中的信息不属于 TI 器件规格的范围，TI 不担保其准确性和完整性。TI 的客户应负责确定器件是否适用于其应用。客户应验证并测试其设计，以确保系统功能。

### 11.1 Application Information

The TPS2583x-Q1 is a step down DC-to-DC regulator and USB charge port controller. It is typically used in automotive systems to convert a DC voltage from the vehicle battery to 5-V DC with a maximum output current of 3.5 A. The following design procedure can be used to select components for the TPS2583x-Q1.

### 11.2 Typical Application

The TPS2583x-Q1 only requires a few external components to convert from a wide voltage range supply to a 5-V output for powering USB devices. 图 11-1 shows a basic schematic.



图 11-1. Application Circuit

The integrated buck regulator of TPS2583x-Q1 is internally compensated and optimized for a reasonable selection of external inductance and capacitance. The external components have to fulfill the needs of the application, but also the stability criteria of the device's control loop. 表 11-2 can be used to simplify the output filter component selection.

#### 11.2.1 Design Requirements

To begin the design process, a few parameters must be known:

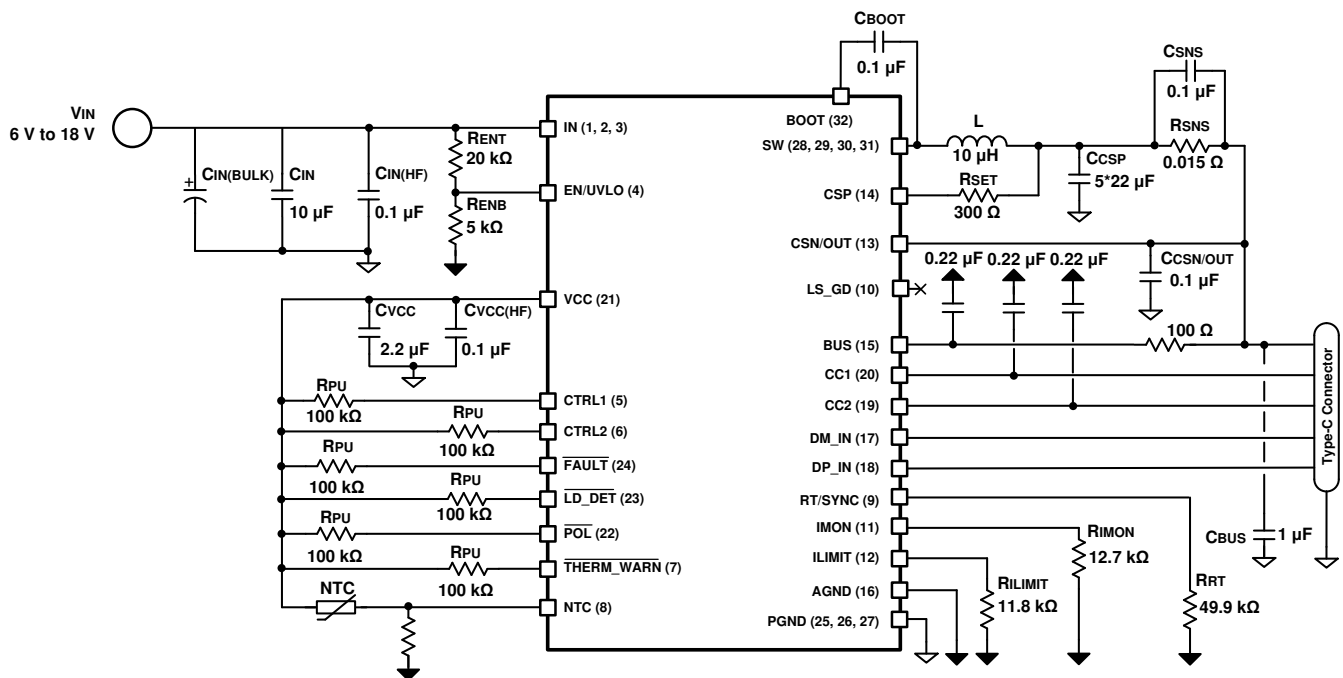
- Cable compensation: Total resistance including cable resistance, contact resistance of connectors, TPS2583x-Q1 current sense resistor and external NFET  $r_{DS(on)}$  (if used). Refer to 图 10-22 for examples of resistances in an automotive application.
- The maximum continuous output current for the charging port. The minimum current-limit setting of TPS2583x-Q1 device must be higher than this current.

For this example, use the parameters listed in 表 11-1 as the input parameters.

**表 11-1. Design Example Parameters**

PARAMETER	VALUE
Input Voltage, $V_{IN}$	13.5-V typical, range from 6 V to 18 V
Output Voltage, $V_{OUT}$	5.1 V
Maximum Output Current $I_{OUT(MAX)}$	3.0 A
Transient Response 0.3 A to 3 A	5%
Output Voltage Ripple	50 mV
Input Voltage Ripple	400 mV
Switching Frequency $f_{SW}$	400 kHz
Cable Resistance for Cable Compensation	300 m $\Omega$
Current Limit by Buck Average	3.3 A

**表 11-2. L and  $C_{OUT}$  Typical Values**

$f_{SW}$	$V_{OUT}$ WITHOUT CABLE COMPENSATION	$C_{IN} + C_{HF}$	L	CURRENT LIMIT	$C_{CSP}$	$C_{CSN/OUT}$	$C_{BUS}$
400 kHz	5.10 V	1 × 10 $\mu$ F + 1 × 100 nF	10 $\mu$ H	Buck Avg	5 × 22 $\mu$ F	100 nF	1 to 4.7 $\mu$ F
400 kHz	5.10 V	1 × 10 $\mu$ F + 1 × 100 nF	10 $\mu$ H	Ext. NFET	5 × 22 $\mu$ F	100 nF	1 to 4.7 $\mu$ F
2100 kHz	5.10 V	1 × 10 $\mu$ F + 1 × 100 nF	2.2 $\mu$ H	Buck Avg	2 × 22 $\mu$ F	100 nF	1 to 4.7 $\mu$ F

1. Inductance value is calculated based on  $V_{IN} = 18$  V.
2. All the  $C_{OUT}$  values are after derating.

## 11.2.2 Detailed Design Procedure

### 11.2.2.1 Output Voltage

The output voltage of TPS2583x-Q1 is internally fixed at 5.10 V. Cable compensation can be used to increase the voltage on the CSN/OUT pin linearly with increasing load current. Refer to the [Cable Compensation](#) section for more details on output voltage variation versus load current. If cable compensation is not desired, use a 0  $\Omega$   $R_{IMON}$  resistor.

### 11.2.2.2 Switching Frequency

The recommended switching frequency of the TPS2583x-Q1 is in the range of 300 to 400 kHz for best efficiency. Choose  $R_{RT} = 49.9$  k $\Omega$  for 400 kHz operation. To choose a different switching frequency, refer to [表 10-1](#).

### 11.2.2.3 Inductor Selection

The most critical parameters for the inductor are the inductance, saturation current and the rated current. The inductance is based on the desired peak-to-peak ripple current  $\Delta i_L$ . Since the ripple current increases with the input voltage, the maximum input voltage is always used to calculate the minimum inductance  $L_{MIN}$ . Use [Equation 10](#) to calculate the minimum value of the output inductor.  $K_{IND}$  is a coefficient that represents the amount of inductor ripple current relative to the maximum output current of the device. A reasonable value of  $K_{IND}$  should be 20% to 40%. During an instantaneous short or overcurrent operation event, the RMS and peak inductor current can be high. The inductor current rating should be higher than the current limit of the device.

$$\Delta i_L = \frac{V_{OUT} \times (V_{IN\_MAX} - V_{OUT})}{V_{IN\_MAX} \times L \times f_{SW}} \quad (9)$$

$$L_{MIN} = \frac{V_{IN\_MAX} - V_{OUT}}{I_{OUT} \times K_{IND}} \times \frac{V_{OUT}}{V_{IN\_MAX} \times f_{SW}} \quad (10)$$

In general, it is preferable to choose lower inductance in switching power supplies, because it usually corresponds to faster transient response, smaller DCR, and reduced size for more compact designs. But too low of an inductance can generate too large of an inductor current ripple such that overcurrent protection at the full

load could be falsely triggered. Larger inductor current ripple also implies larger output voltage ripple with same output capacitors. With peak current mode control, it is not recommended to have too small of an inductor current ripple. A larger peak current ripple improves the comparator signal to noise ratio.

For this design example, choose  $K_{IND} = 0.3$ , the minimum inductor value is calculated to be 8.7  $\mu\text{H}$ . Choose the nearest standard 10- $\mu\text{H}$  ferrite inductor with a capability of 4-A RMS current and 6-A saturation current.

#### 11.2.2.4 Output Capacitor Selection

The value of the output capacitor, and its ESR, determine the output voltage ripple and load transient performance. The output capacitor bank is usually limited by the load transient requirements, rather than the output voltage ripple. Equation 11 can be used to estimate a lower bound on the total output capacitance, and an upper bound on the ESR, required to meet a specified load transient.

$$C_{OUT} \geq \frac{\Delta I_{OUT}}{f_{SW} \cdot \Delta V_{OUT} \cdot K} \cdot \left[ (1-D) \cdot (1+K) + \frac{K^2}{12} \cdot (2-D) \right]$$

$$ESR \leq \frac{(2+K) \cdot \Delta V_{OUT}}{2 \cdot \Delta I_{OUT} \left[ 1+K + \frac{K^2}{12} \cdot \left( 1 + \frac{1}{(1-D)} \right) \right]}$$

$$D = \frac{V_{OUT}}{V_{IN}} \tag{11}$$

where

- $\Delta V_{OUT}$  = output voltage transient
- $\Delta I_{OUT}$  = output current transient
- $K$  = Ripple factor from [Inductor Selection](#)

Once the output capacitor and ESR have been calculated, Equation 12 can be used to check the peak-to-peak output voltage ripple;  $V_r$ .

$$V_r \cong \Delta I_L \cdot \sqrt{ESR^2 + \frac{1}{(8 \cdot f_{SW} \cdot C_{OUT})^2}} \tag{12}$$

The output capacitor and ESR can then be adjusted to meet both the load transient and output ripple requirements.

For this example we require a  $\Delta V_{OUT}$  of  $\leq 250$  mV for an output current step of  $\Delta I_{OUT} = 2.7$  A. Equation 11 gives a minimum value of 86  $\mu\text{F}$  and a maximum ESR of 0.08  $\Omega$ . Assuming a 20% tolerance and a 10% bias de-rating, we arrive at a minimum capacitance of 110  $\mu\text{F}$ . This can be achieved with a bank of 5  $\times$  22- $\mu\text{F}$ , 10-V, ceramic capacitors in the 1210 case size. More output capacitance can be used to improve the load transient response. Ceramic capacitors can easily meet the minimum ESR requirements. In some cases an aluminum electrolytic capacitor can be placed in parallel with the ceramics to help build up the required value of capacitance.

In practice the output capacitor has the most influence on the transient response and loop phase margin. Load transient testing and Bode plots are the best way to validate any given design and should always be completed before the application goes into production. In addition to the required output capacitance, a small ceramic placed on the output can help to reduce high frequency noise. Small case size ceramic capacitors in the range of 1 nF to 100 nF can be very helpful in reducing voltage spikes on the output caused by inductor and board parasitics.

The maximum value of total output capacitance should be limited to about 10 times the design value, or 1000  $\mu\text{F}$ , whichever is smaller. Large values of output capacitance can adversely affect the start-up behavior of the regulator as well as the loop stability. If values larger than noted here must be used, then a careful study of start-up at full load and loop stability must be performed.

#### 11.2.2.5 Input Capacitor Selection

The TPS2583x-Q1 device requires high frequency input decoupling capacitor(s) and a bulk input capacitor, depending on the application. A high-quality ceramic capacitor type X5R or X7R with sufficient voltage ratings are recommended. To compensate the derating of ceramic capacitors, a voltage rating of twice the maximum input voltage is recommended. The bulk capacitance selection depends upon a number of factors: long leads from the automotive battery to the IN pin of TPS2583x-Q1, cold or warm engine crank requirements, etc. The bulk capacitor is used to dampen voltage spike due to the lead inductance of the cable or the trace. For this design, one 10  $\mu\text{F}$ , 50 V, X7R ceramic capacitors are used. A 0.1  $\mu\text{F}$  for high-frequency filtering and place it as close as possible to the device pins. Consider adding additional bulk capacitance for operation through low  $V_{\text{IN}}$  warm-crank profiles is required by the vehicle OEM.

#### 11.2.2.6 Bootstrap Capacitor Selection

Every TPS2583x-Q1 design requires a bootstrap capacitor ( $C_{\text{BOOT}}$ ). The recommended capacitor is 0.1  $\mu\text{F}$  and rated 10 V or higher. The bootstrap capacitor is located between the SW pin and the BOOT pin. The bootstrap capacitor must be a high-quality ceramic type with an X7R or X5R grade dielectric for temperature stability.

#### 11.2.2.7 VCC Capacitor Selection

The VCC pin is the output of an internal LDO for TPS2583x. The LDO supplies gate charge to the LS buck switch and is the supply to the digital state-machine and analog USB circuitry. To insure stability of the device, place a minimum of 2.2  $\mu\text{F}$ , 10 V, X7R capacitor from this pin to ground. In addition a 0.1-  $\mu\text{F}$  high frequency decoupling capacitor is highly recommended.

#### 11.2.2.8 Enable and Undervoltage Lockout Set-Point

The system enable and undervoltage lockout (UVLO) is adjusted using the external voltage divider network of  $R_{\text{ENT}}$  and  $R_{\text{ENB}}$ . The EN/UVLO has two thresholds, one for power up when the input voltage is rising and one for power down or brown outs when the input voltage is falling. The following equations can be used to determine the  $V_{\text{IN(ON)}}$  and  $V_{\text{IN(OFF)}}$  levels.

$$R_{\text{ENT}} = \left( \frac{V_{\text{IN(ON)}}}{V_{\text{EN/UVLO\_H}}} - 1 \right) \times R_{\text{ENB}} \quad (13)$$

$$V_{\text{IN(OFF)}} = V_{\text{IN(ON)}} \times \left( 1 - \frac{V_{\text{EN/UVLO\_HYS}}}{V_{\text{EN/UVLO\_H}}} \right) \quad (14)$$

$V_{\text{IN(ON)}} = 6 \text{ V}$  (user choice)

$R_{\text{ENB}} = 5 \text{ k}\Omega$  (user choice)

$R_{\text{ENT}} = [(V_{\text{IN(ON)}} / V_{\text{EN/UVLO\_H}}) - 1] \times R_{\text{ENB}}$

$R_{\text{ENT}} = [(6 \text{ V} / 1.2 \text{ V}) - 1] \times 5 \text{ k}\Omega = 20 \text{ k}\Omega$ . Choose standard 20 k  $\Omega$ .

Therefore  $V_{\text{IN(OFF)}} = 6 \text{ V} \times [1 - (0.09 \text{ V} / 1.2 \text{ V})] = 5.55 \text{ V}$

#### 11.2.2.9 Current Limit Set-Point

The TPS2583x-Q1 can provide an accurate current limit to protect the USB port from overload based upon the values of  $R_{\text{SNS}}$ ,  $R_{\text{SET}}$  and  $R_{\text{LIMIT}}$ . The design process is the same regardless of whether buck average current limiting or external NFET current limiting is chosen. The only difference is the current limit threshold voltage on the ILIMIT pin.

- $R_{SNS}$  is the current sense resistor. The recommended voltage across the  $R_{SNS}$  undercurrent limit should be approximately 50 mV as a compromise between accuracy and power dissipation. For example, if current limiting is desired for  $I_{OUT(MAX)} \geq 3.3$  A, then  $R_{SNS} = 0.05$  V / 3.3 A = 0.01515  $\Omega$ . Choose a standard value of 15 m $\Omega$ .
- $R_{SET}$  determines the input current to the transconductance amplifier and current mirror. The amplifier balances the voltage to be equal to that across  $R_{SNS}$ . Choose a  $R_{SET}$  value to produce an  $I_{SET}$  current between 75 - 180  $\mu$ A at the desired  $I_{OUT(MAX)}$ . Considering 50 mV across  $R_{SET}$ , a value of 300  $\Omega$  will provide approximately 166  $\mu$ A of  $I_{SET}$  current to the amplifier and mirror circuit. Care should be taken to limit the  $I_{SET}$  current below 200  $\mu$ A to avoid saturating the internal amplifier circuit.
- Buck average current limiting occurs when  $V_{LIMIT} = 1$  V.  $R_{LIMIT}$  is calculated as  $1$  V x 300  $\Omega$  / [ 0.5 x (3.3 A x 15 m $\Omega$  + 0.7 mV) ] = 11.95 k $\Omega$ . A standard 11.8 k $\Omega$  value is chosen.

#### 11.2.2.10 Cable Compensation Set-Point

From 表 11-1 the total cable resistance to be accounted for is 300 m $\Omega$ .

1. From [Current Limit Set-Point](#)  $R_{SNS}$  and  $R_{SET}$  have been determined as 15 m $\Omega$  and 300  $\Omega$ , respectively.
2.  $R_{WIRE} = 300$  m $\Omega$
3.  $\Delta V_{OUT} = (R_{SNS} + R_{WIRE}) \times I_{BUS} = (0.015 + 0.3) \times 3 = 1.0395$  V
4.  $R_{MON} = (\Delta V_{OUT} \times R_{SET} \times 2) / (I_{BUS} \times R_{SNS}) = (1.0395 \times 300 \times 2) / (3.3 \times 0.015) = 12.6$  k $\Omega$ . A standard value of 12.7 k $\Omega$  is selected.

#### 11.2.2.11 LD\_DET, POL, and FAULT Resistor Selection

The  $\overline{LD\_DET}$ ,  $\overline{POL}$ , and  $\overline{FAULT}$  pins are open-drain output flags. They can be connected to the TPS2583x-Q1 VCC pin with 100-k $\Omega$  resistors, or connected to another suitable I/O voltage supply if actively monitored by a USB HUB or MCU. They can be left floating if unused.

### 11.2.3 Application Curves

Unless otherwise specified the following conditions apply:  $V_{IN} = 13.5\text{ V}$ ,  $f_{SW} = 400\text{ kHz}$ ,  $L = 10\text{ }\mu\text{H}$ ,  $C_{OUT\_CSP} = 66\text{ }\mu\text{F}$ ,  $C_{OUT\_CSN} = 0.1\text{ }\mu\text{F}$ ,  $C_{BUS} = 1\text{ }\mu\text{F}$ ,  $T_A = 25\text{ }^\circ\text{C}$ .



图 11-2. Buck Only Efficiency



图 11-3. Buck Only Efficiency

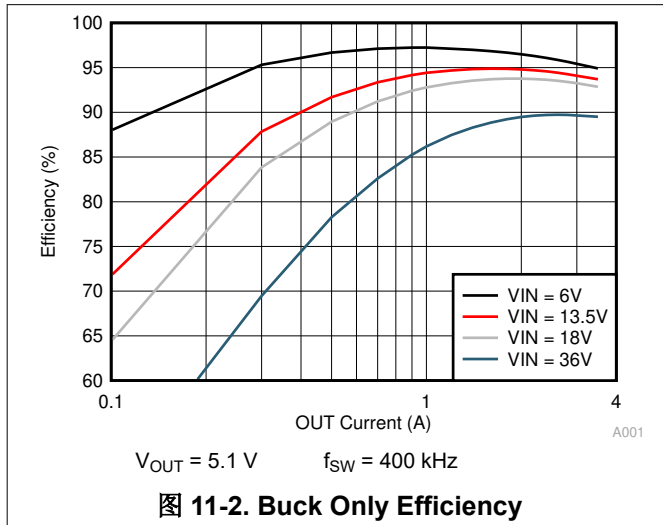

图 11-4. Efficiency With Sense Resistor

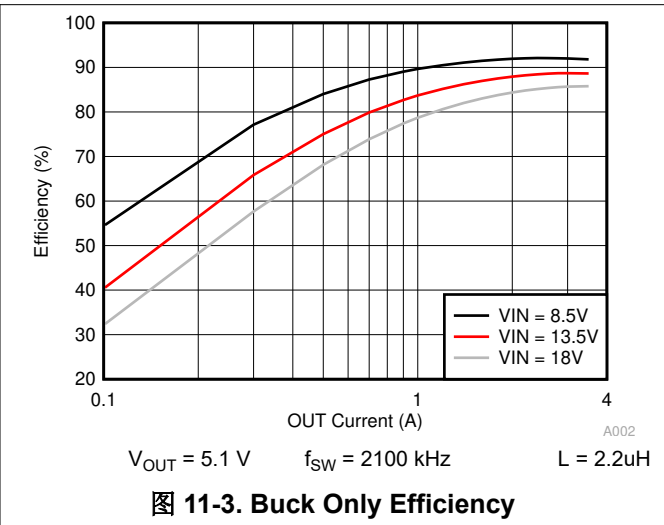

图 11-5. Efficiency With Sense Resistor

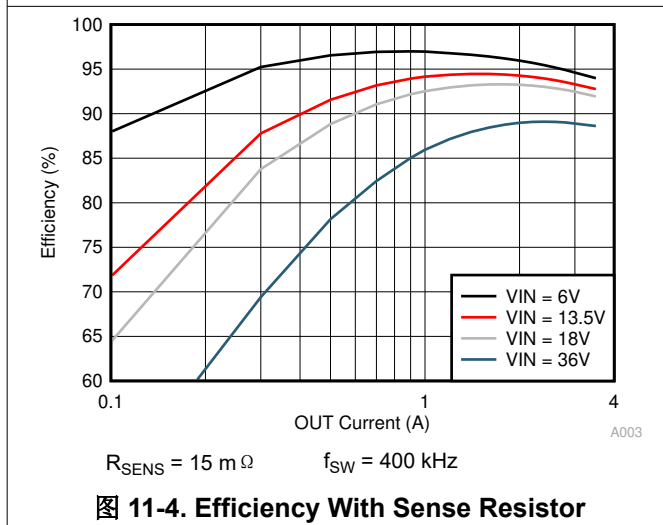

图 11-6. Load Regulation

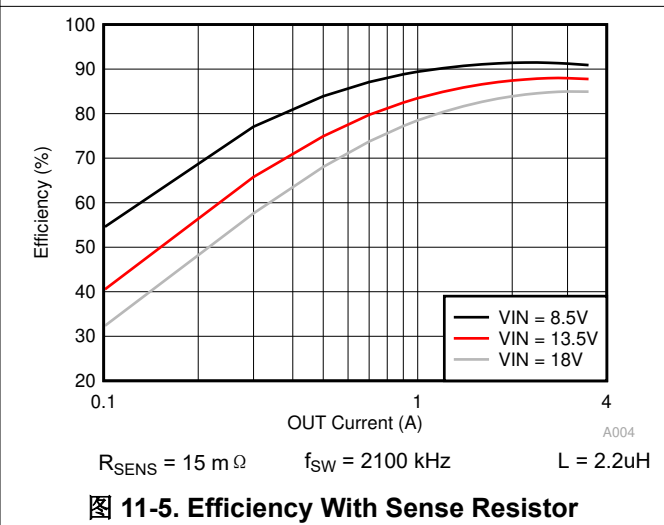

图 11-7. Line Regulation

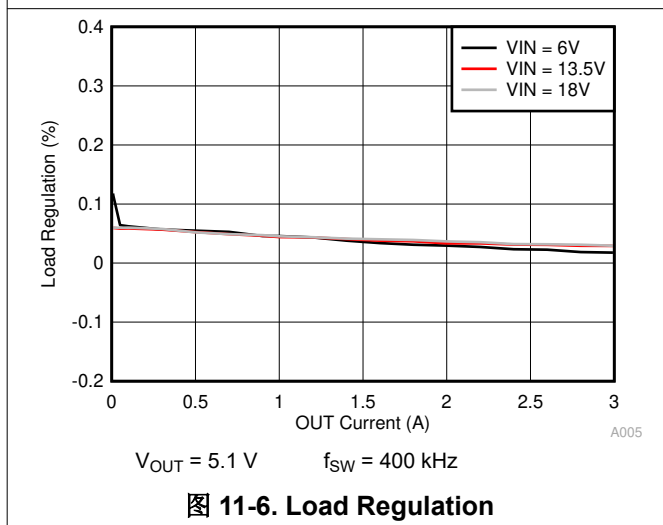

图 11-8. Load Transient Without Cable Compensation

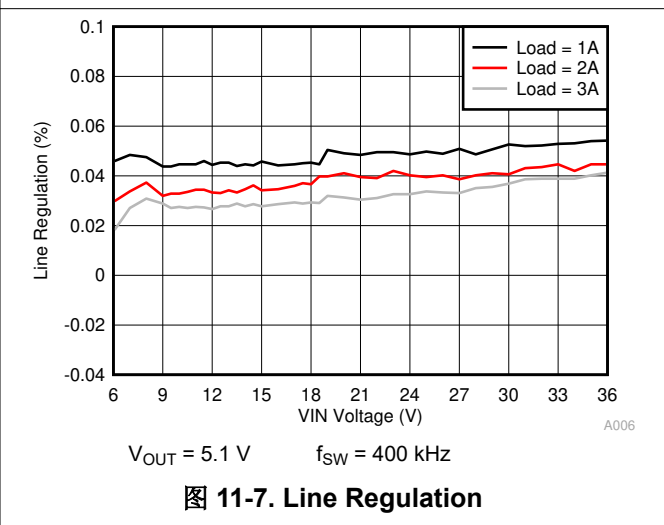

图 11-9. Load Transient Without Cable Compensation

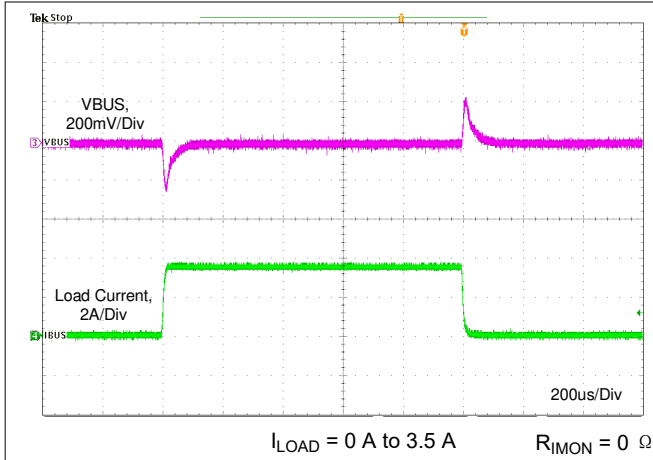

图 11-10. Load Transient With Cable Compensation

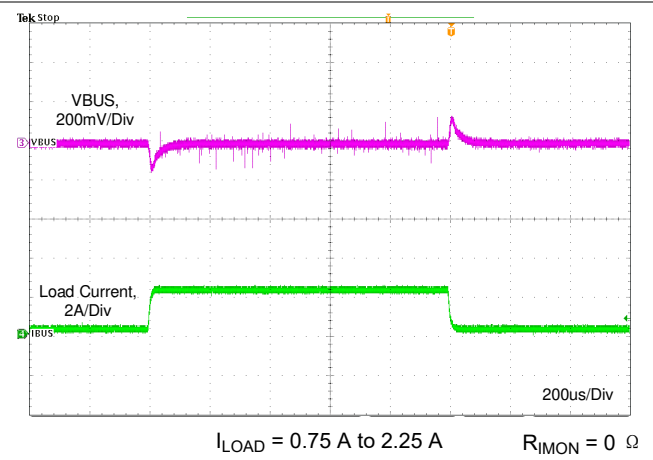

图 11-11. Load Transient With Cable Compensation

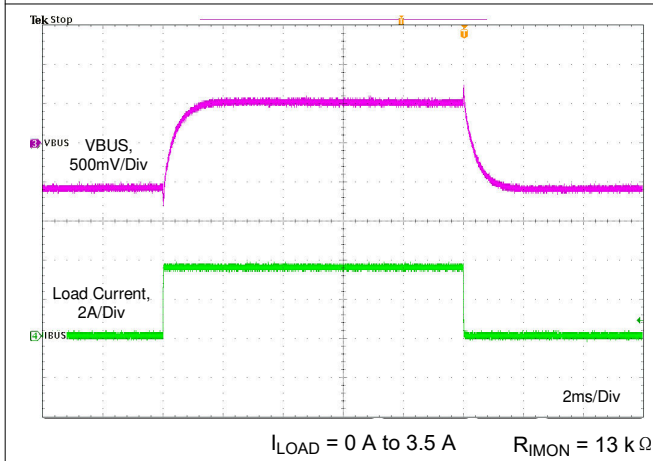

图 11-12. Dropout Characteristic

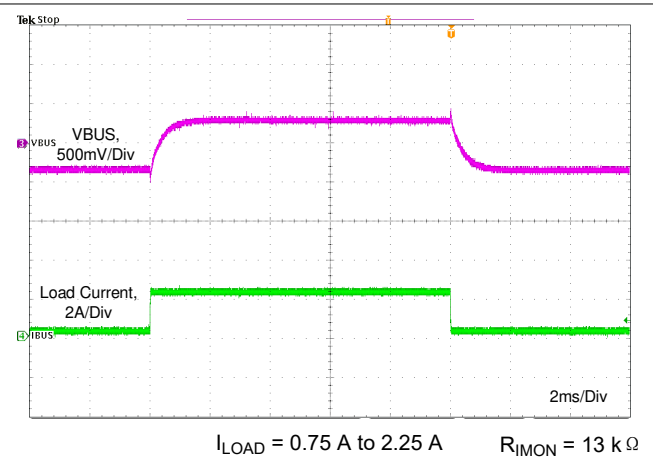

图 11-13. 3.5-A Output Ripple

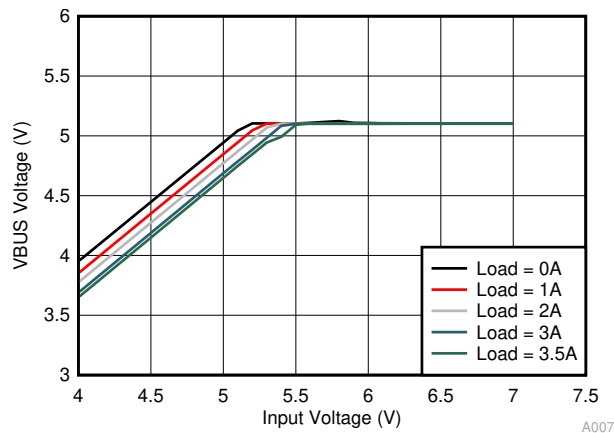

图 11-14. 100-mA Output Ripple

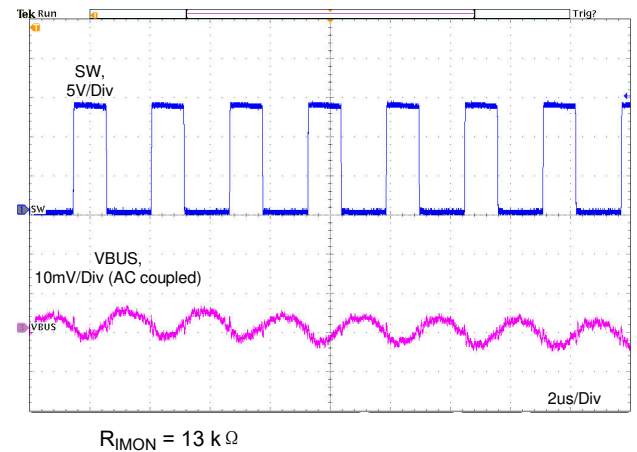

图 11-15. No Load Output Ripple

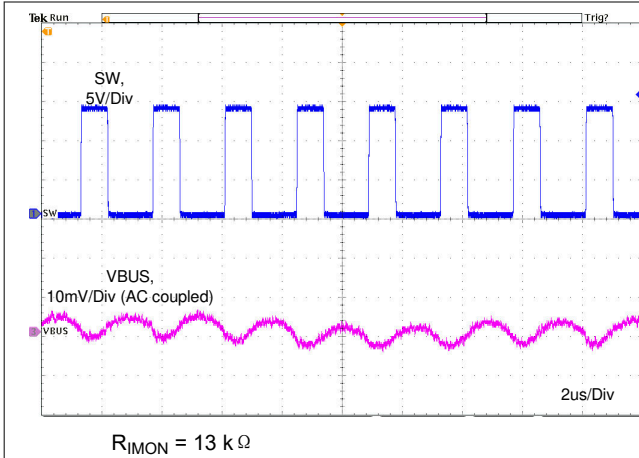

图 11-16. Startup Relate to VIN

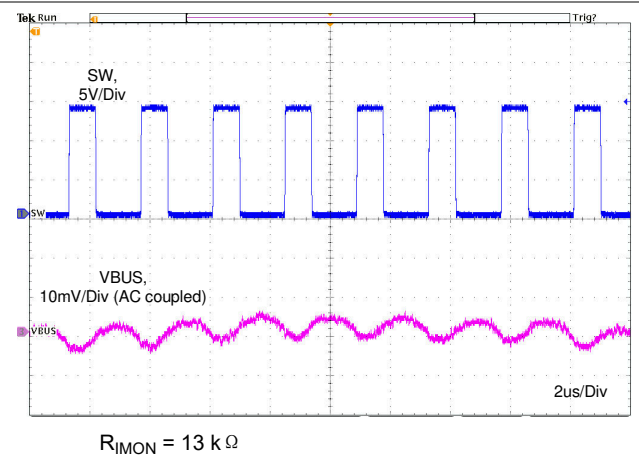

图 11-17. Shutdown Relate to VIN

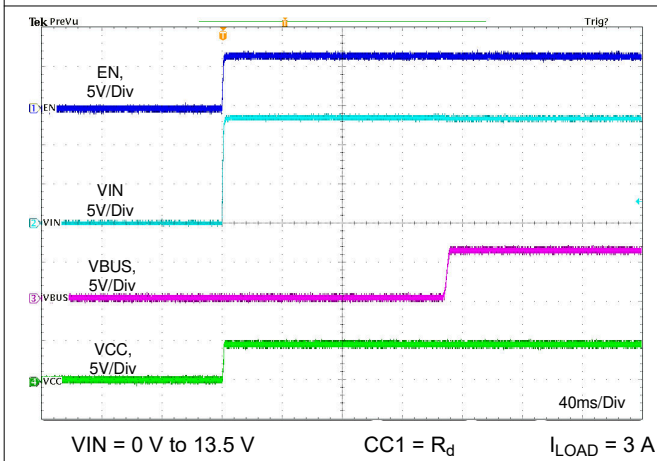

图 11-18. Startup Relate to EN

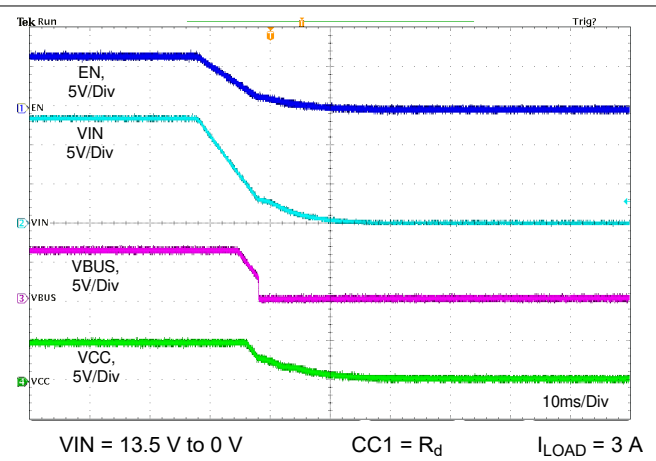

图 11-19. Shutdown Relate to EN

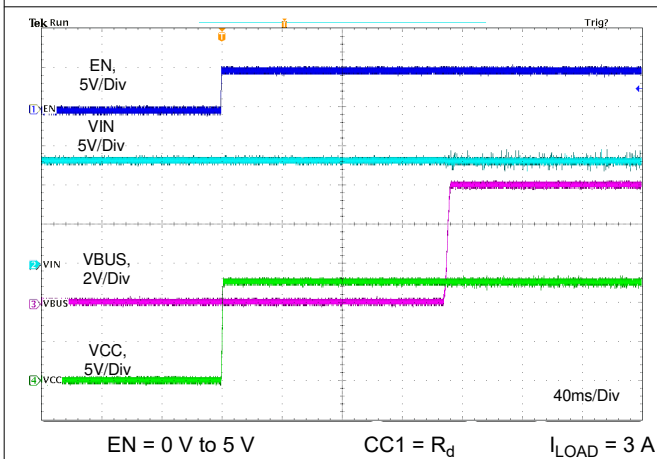

图 11-20. Rd Assert

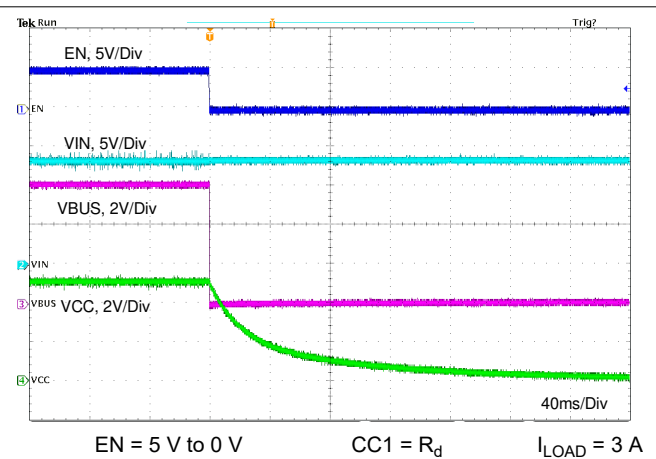

图 11-21. Rd Desert

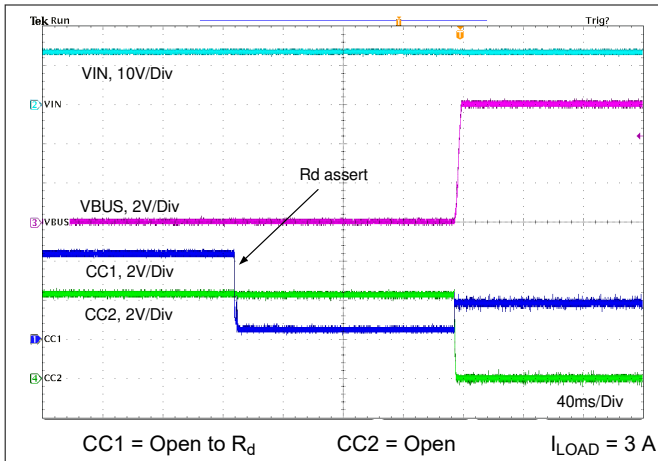

图 11-22. Enable Into Short Without External FET

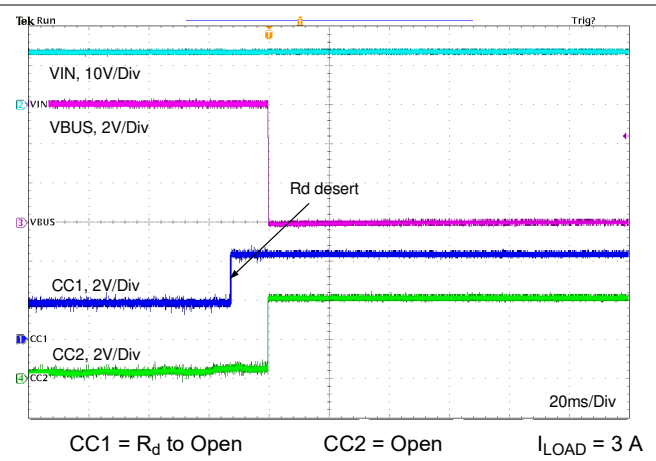

图 11-23. Short Circuit Recovery Without External FET

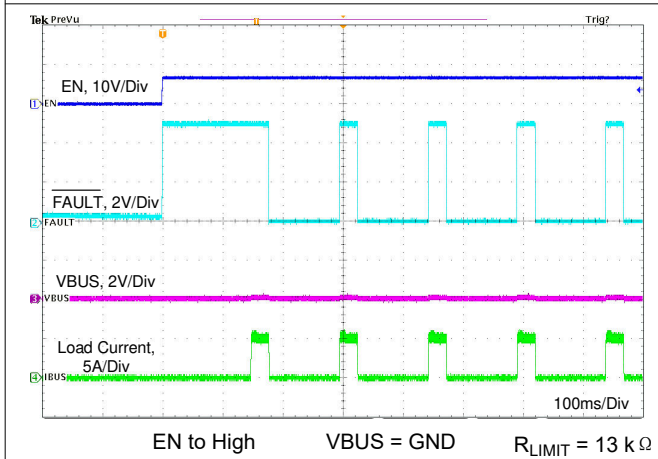

图 11-24. Enable Into 1-Ω Load Without External FET

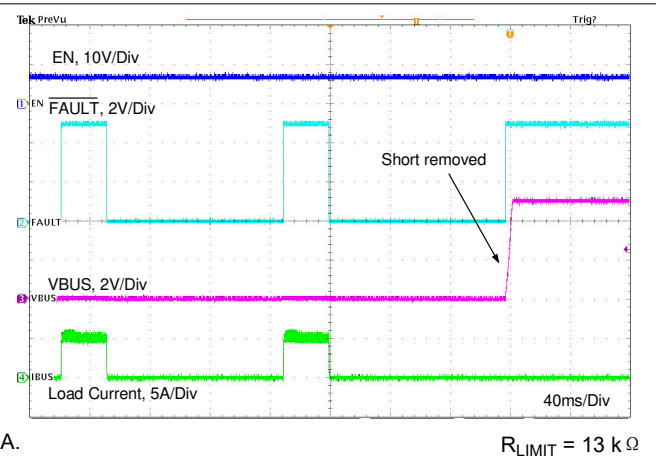

图 11-25. 1-Ω Load Recovery Without External FET

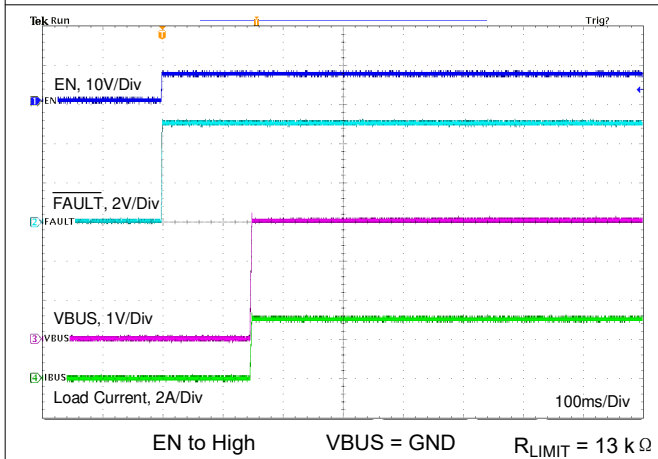

图 11-26. Enable Into Short With External FET

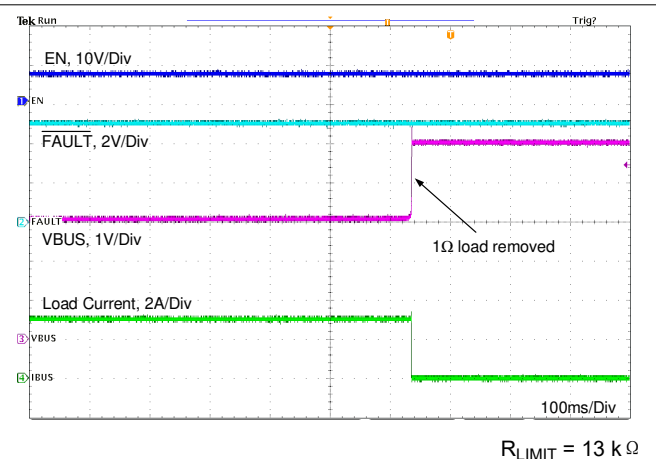

图 11-27. Short Circuit Recovery With External FET

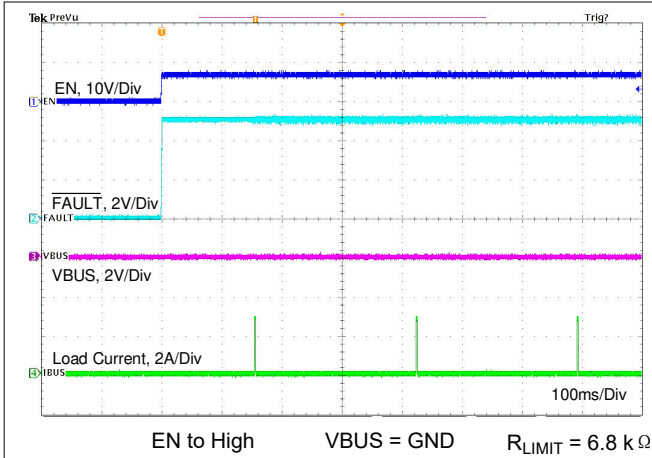

图 11-28. VBUS Hot Short to GND Without External FET

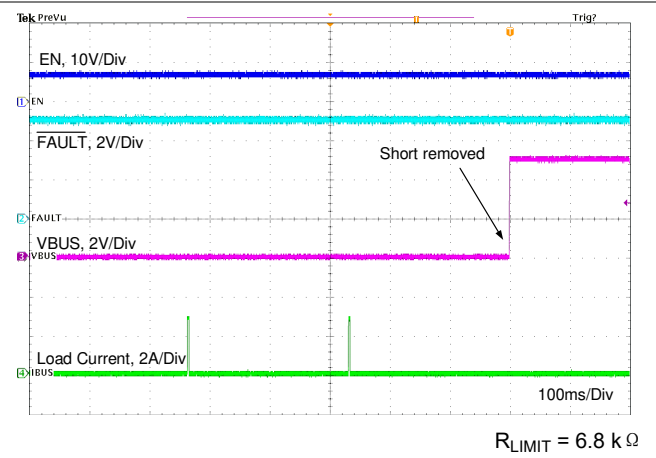

图 11-29. VBUS Hot Short to GND With External FET

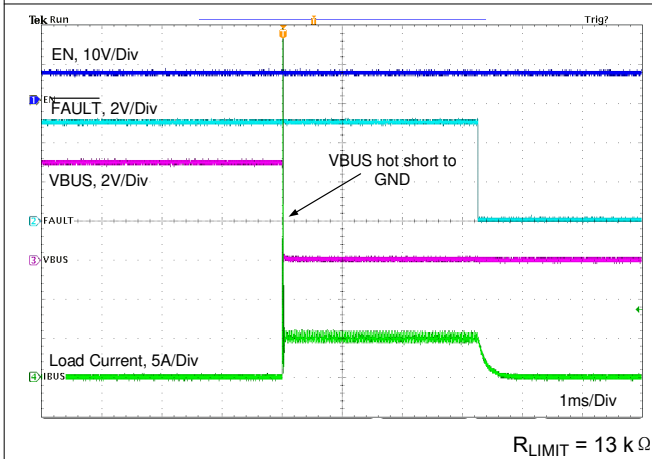

图 11-30. CC2 Hot Short to GND

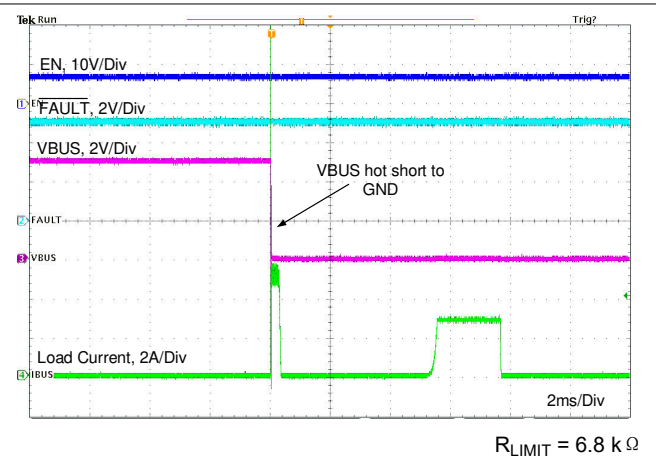

图 11-31. VBUS Short to BAT With External FET

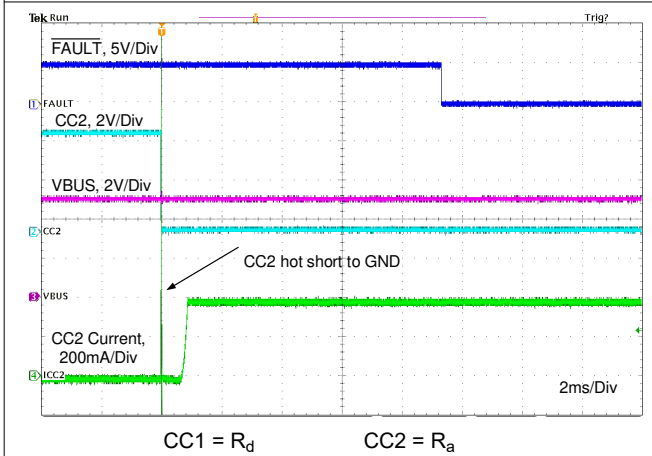

图 11-32. VBUS Short to BAT Recovery With External FET

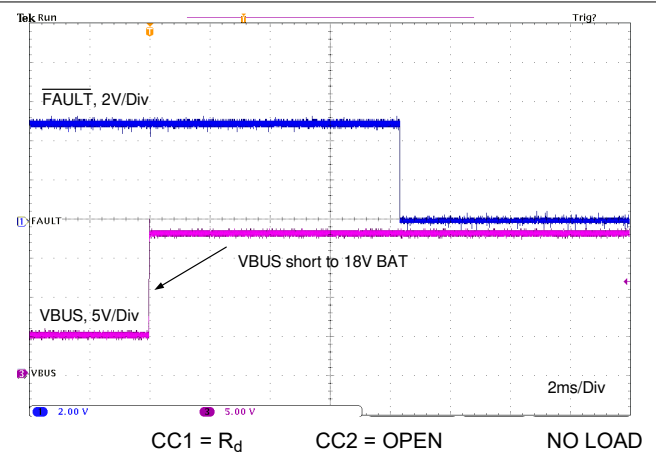

图 11-33. CC Short to BAT

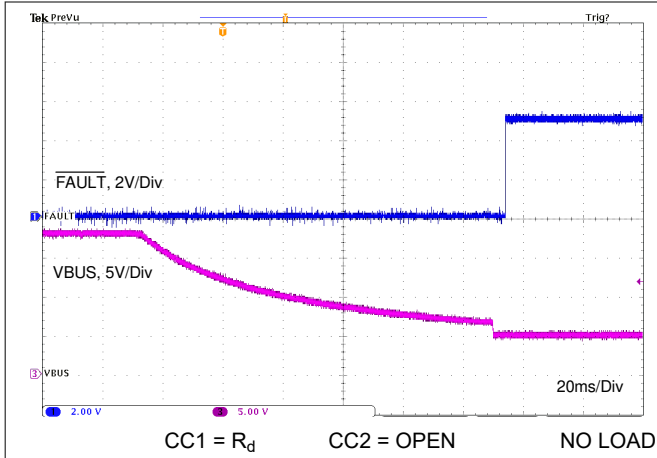

图 11-34. CC Short to BAT Recovery

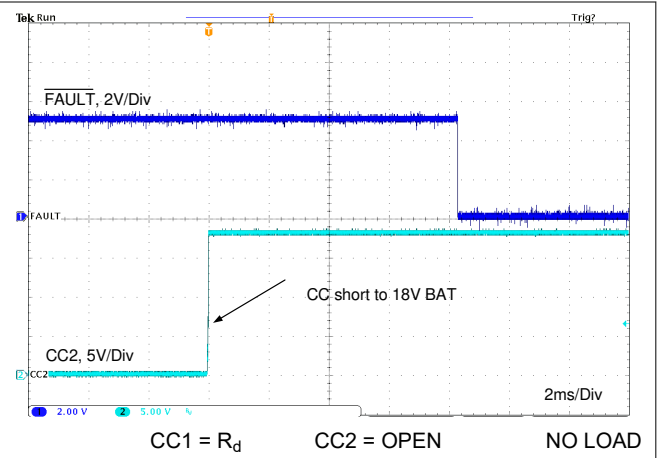

图 11-35. DP Short to BAT

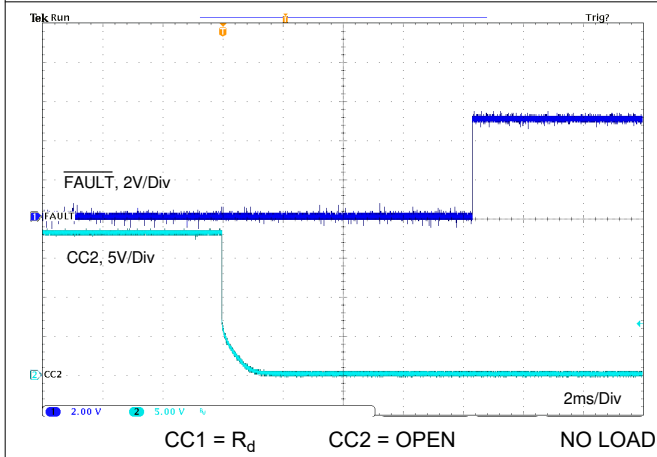

图 11-36. DP Short to BAT Recovery

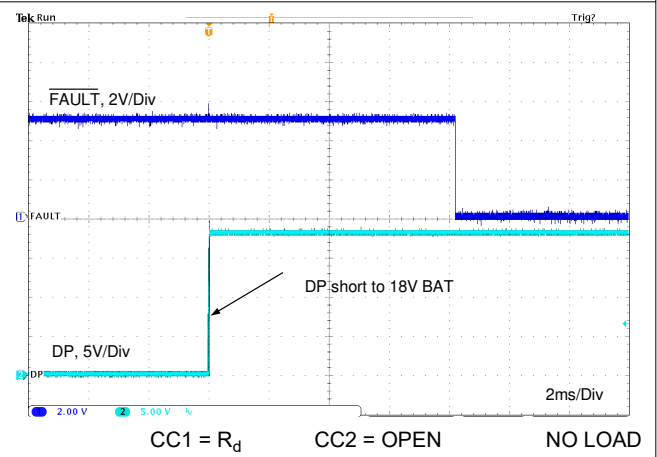

图 11-37. Thermal Sensing With NTC Behavior 1

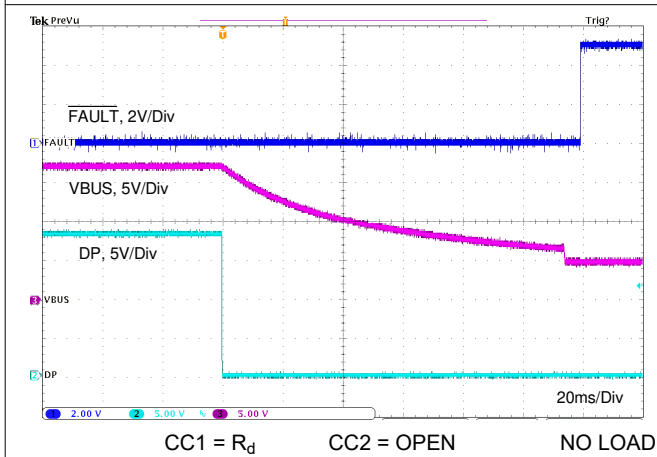

## 12 Power Supply Recommendations

The TPS2583x-Q1 is designed to operate from an input voltage supply range between 6 V and 36 V. This input supply should be able to withstand the maximum input current and maintain a stable voltage. The resistance of the input supply rail should be low enough that an input current transient does not cause a high enough drop at the TPS2583x-Q1 supply voltage that can cause a false UVLO fault triggering and system reset. If the input supply is located more than a few inches from the TPS2583x, additional bulk capacitance may be required in addition to the ceramic input capacitors. The amount of bulk capacitance is not critical, but a 47- $\mu$ F or 100- $\mu$ F electrolytic capacitor is a typical choice.

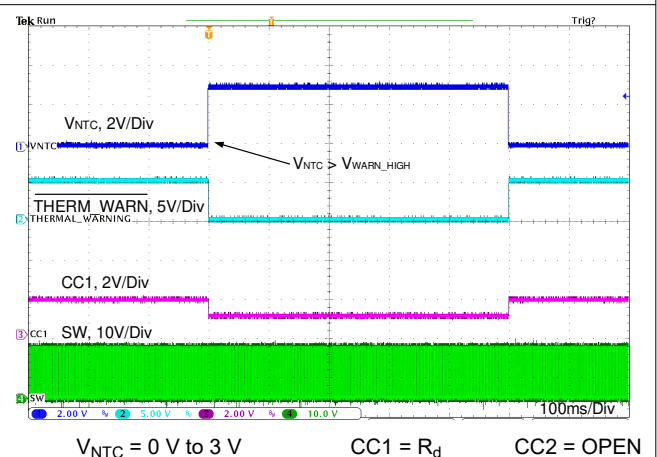
## 13 Layout

### 13.1 Layout Guidelines

Layout is a critical portion of good power supply design. The following guidelines will help users design a PCB with the best power conversion performance, thermal performance, and minimized generation of unwanted EMI. For more detailed EMC design consideration and test report, please refer to the [PCB Layout and Parameters Recommendation for TPS2583X EMC Performance Application Report](#).

1. **Input capacitor:** The input bypass capacitor  $C_{IN}$  must be placed as close as possible to the IN and PGND pins. Grounding for both the input and output capacitors should consist of localized top side planes that connect to the PGND pin and PAD. A combination of different values and packages of capacitors can help improve the EMC performance (for example: 10  $\mu$ F + 0.1  $\mu$ F + 2.2nF). Besides, the distance between the input filter section and the output power section must be at least 15mm to prevent the output high-frequency signal from coupling into the input filter. A 10 $\mu$ F cap cross  $V_{IN}$  and PGND pin on top of SW is suggested for TPS2583x-Q1.
2.  **$V_{CC}$  bypass capacitor:** Place bypass capacitors for  $V_{CC}$  close to the VCC pin and ground the bypass capacitor to device ground.
3. Use a ground plane in one of the middle layers as noise shielding and heat dissipation path.
4. Connect the thermal pad to the ground plane. The QFN package has a thermal pad (PAD) connection that must be soldered down to the PCB ground plane. This pad acts as a heat-sink connection. The integrity of this solder connection has a direct bearing on the total effective  $R_{\theta JA}$  of the application.
5. Make  $V_{IN}$ ,  $V_{OUT}$  and ground bus connections as wide as possible. This reduces any voltage drops on the input or output paths of the converter and maximizes efficiency.
6. Provide enough PCB area for proper heat sinking. As stated in the section, enough copper area must be used to ensure a low  $R_{\theta JA}$ , commensurate with the maximum load current and ambient temperature. Make the top and bottom PCB layers with two-ounce copper; and no less than one ounce. Use an array of heat-sinking vias to connect the thermal pad (PAD) to the ground plane on the bottom PCB layer. If the PCB design uses multiple copper layers (recommended), thermal vias can also be connected to the inner layer heat-spreading ground planes.
7. The SW pin connecting to the inductor should be as short as possible, and just wide enough to carry the load current without excessive heating. Short, thick traces or copper pours (shapes) will bring a high current conduction capacity to minimize parasitic resistance, but it will also cause a larger parasitic capacitance. Thus a balance should be found between smaller parasitic resistance and larger parasitic capacitance. And the current path should be kept straight forward to the inductor, otherwise the L-shaped or T-shaped path will make a sudden change of the impedance which causes signal reflection and impacts the performance of EMC. The output capacitors should be placed close to the  $V_{OUT}$  end of the inductor and closely grounded to PGND pin and exposed PAD. Besides, do not punch vias on SW lines. Using shielded inductors or molded inductors to reduce high-frequency radiation.
8. **Sense and Set Resistors:** The  $R_{SNS}$  and  $R_{SET}$  resistors connect to the current sense amplifier inputs at the CSP and CSN/OUT pins. For best current limit and cable compensation accuracy; short, parallel traces give the best performance. If it is not possible to place  $R_{SNS}$  and  $R_{SET}$  near the CSP and CSN/OUT pins, it is recommended that the traces from sense resistor be routed in parallel and of similar lengths. A small filter capacitor in parallel with  $R_{SNS}$  and a small filter capacitor from CSN/OUT to AGND help decouple noise.
9.  $R_{LIMIT}$  and  $R_{IMON}$  resistors should be placed as close as possible to the ILIMIT and IMON pins and connected to AGND. If needed, these components can be placed on the bottom side of the PCB with signals routed through small vias.

10. Trace routing of DP\_IN, DM\_IN, DP\_OUT, and DM\_OUT: Route these traces as micro-strips with nominal differential impedance of 90 Ω. Minimize the use of vias in the high-speed data lines. Keep the reference GND plane devoid from cuts or splits above the differential pairs to prevent impedance discontinuities.
11. Keep the CC lines close to the same length. Do not create stubs or test points on the CC lines.
12. POL, LD\_DET, FAULT and THERM\_WARN (TPS25831-Q1) are open-drain outputs. They can be connected to the VCC pin via pull-up resistors. Suggested resistor value is 100 kΩ.
13. The area enclosed by current loop of input side and output side should be as small as possible; the area enclosed by the BOOT circuit should be as small as possible.
14. Power ground PGND and the signal ground AGND should be separated in the actual PCB layout.

### 13.2 Ground Plane and Thermal Considerations

It is recommended to use one of the middle layers as a solid ground plane. Ground plane provides shielding for sensitive circuits and traces. It also provides a quiet reference potential for the control circuitry. The PGND pins should be connected to the ground plane using vias right next to the bypass capacitors. PGND pin is connected to the source of the internal LS switch. The PGND net contains noise at switching frequency and may bounce due to load variations. PGND trace, as well as VIN and SW traces, should be constrained to one side of the ground plane. The other side of the ground plane contains much less noise and should be used for sensitive routes. AGND and PGND should be connected under the QFN package PAD.

It is recommended to provide adequate device heat sinking by utilizing the PAD of the IC as the primary thermal path. Use a minimum 2 row, 2 column "+" array of 12 mil thermal vias to connect the PAD to the system ground plane heat sink. The vias should be evenly distributed under the PAD. Use as much copper as possible, for system ground plane, on the top and bottom layers for the best heat dissipation. Use a four-layer board with the copper thickness for the four layers, starting from the top of, 2 oz / 1 oz / 1 oz / 2 oz. Four layer boards with enough copper thickness provide low current conduction impedance, proper shielding and lower thermal resistance.

The thermal characteristics of the TPS2583x-Q1 are specified using the parameter  $\theta_{JA}$ , which characterize the junction temperature of silicon to the ambient temperature in a specific system. Although the value of  $\theta_{JA}$  is dependent on many variables, it still can be used to approximate the operating junction temperature of the device. To obtain an estimate of the device junction temperature, one may use the following relationship:

$$T_J = P_D \times \theta_{JA} + T_A \quad (15)$$

where

$T_J$  = Junction temperature in °C

$P_D = V_{IN} \times I_{IN} \times (1 - \text{Efficiency}) - 1.1 \times I_{OUT}^2 \times \text{DCR}$  in Watt

DCR = Inductor DC parasitic resistance in Ω

$\theta_{JA}$  = Junction to ambient thermal resistance of the device in °C/W

$T_A$  = Ambient temperature in °C

$\theta_{JA}$  is highly related to PCB size and layout, as well as environmental factors such as heat sinking and air flow.

### 13.3 Layout Example



图 13-1. Layout

## 14 Device and Documentation Support

### 14.1 Related Links

The table below lists quick access links. Categories include technical documents, support and community resources, tools and software, and quick access to sample or buy.

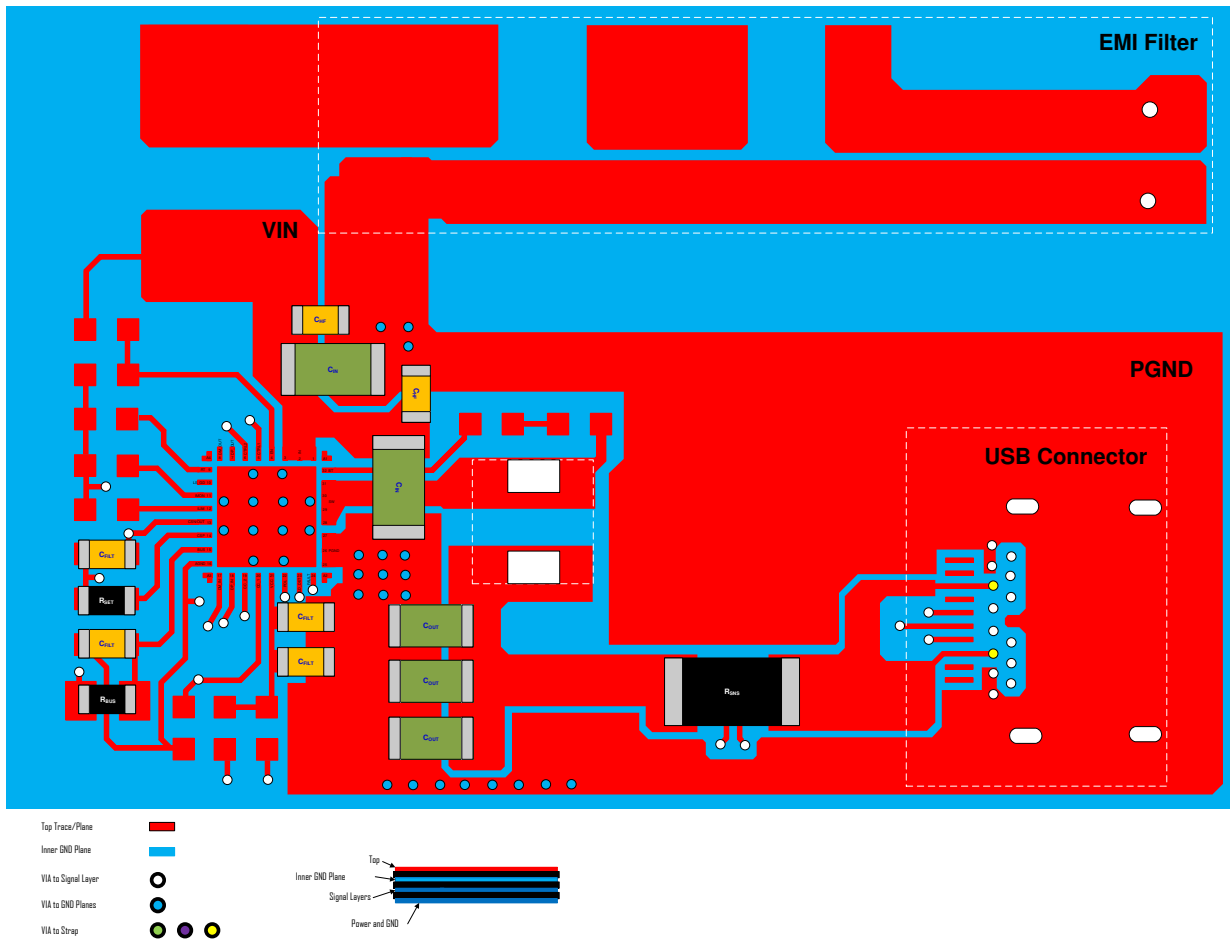
**表 14-1. Related Links**

PARTS	PRODUCT FOLDER	ORDER NOW	TECHNICAL DOCUMENTS	TOOLS & SOFTWARE	SUPPORT & COMMUNITY
TPS25830-Q1	<a href="#">Click here</a>	<a href="#">Click here</a>	<a href="#">Click here</a>	<a href="#">Click here</a>	<a href="#">Click here</a>
TPS25831-Q1	<a href="#">Click here</a>	<a href="#">Click here</a>	<a href="#">Click here</a>	<a href="#">Click here</a>	<a href="#">Click here</a>

### 14.2 接收文档更新通知

要接收文档更新通知，请导航至 [ti.com](http://ti.com) 上的器件产品文件夹。点击 [订阅更新](#) 进行注册，即可每周接收产品信息更改摘要。有关更改的详细信息，请查看任何已修订文档中包含的修订历史记录。

### 14.3 支持资源

[TI E2E™ 支持论坛](#) 是工程师的重要参考资料，可直接从专家获得快速、经过验证的解答和设计帮助。搜索现有解答或提出自己的问题可获得所需的快速设计帮助。

链接的内容由各个贡献者“按原样”提供。这些内容并不构成 TI 技术规范，并且不一定反映 TI 的观点；请参阅 TI 的《[使用条款](#)》。

### 14.4 Trademarks

TI E2E™ is a trademark of Texas Instruments.

USB Type-C® is a registered trademark of USB Implementers Forum.

所有商标均为其各自所有者的财产。

### 14.5 Electrostatic Discharge Caution



This integrated circuit can be damaged by ESD. Texas Instruments recommends that all integrated circuits be handled with appropriate precautions. Failure to observe proper handling and installation procedures can cause damage.

ESD damage can range from subtle performance degradation to complete device failure. Precision integrated circuits may be more susceptible to damage because very small parametric changes could cause the device not to meet its published specifications.

### 14.6 术语表

[TI 术语表](#) 本术语表列出并解释了术语、首字母缩略词和定义。

## 15 Mechanical, Packaging, and Orderable Information

The following pages include mechanical, packaging, and orderable information. This information is the most current data available for the designated devices. This data is subject to change without notice and revision of this document. For browser-based versions of this data sheet, refer to the left-hand navigation.

## 重要声明和免责声明

TI 提供技术和可靠性数据 (包括数据表)、设计资源 (包括参考设计)、应用或其他设计建议、网络工具、安全信息和其他资源, 不保证没有瑕疵且不做任何明示或暗示的担保, 包括但不限于对适销性、某特定用途方面的适用性或不侵犯任何第三方知识产权的暗示担保。

这些资源可供使用 TI 产品进行设计的熟练开发人员使用。您将自行承担以下全部责任: (1) 针对您的应用选择合适的 TI 产品, (2) 设计、验证并测试您的应用, (3) 确保您的应用满足相应标准以及任何其他安全、安保或其他要求。这些资源如有变更, 恕不另行通知。TI 授权您仅可将这些资源用于研发本资源所述的 TI 产品的应用。严禁对这些资源进行其他复制或展示。您无权使用任何其他 TI 知识产权或任何第三方知识产权。您应全额赔偿因在这些资源的使用中对 TI 及其代表造成的任何索赔、损害、成本、损失和债务, TI 对此概不负责。

TI 提供的产品受 TI 的销售条款 (<https://www.ti.com/legal/termsofsale.html>) 或 [ti.com](https://www.ti.com) 上其他适用条款/TI 产品随附的其他适用条款的约束。TI 提供这些资源并不会扩展或以其他方式更改 TI 针对 TI 产品发布的适用的担保或担保免责声明。

邮寄地址: Texas Instruments, Post Office Box 655303, Dallas, Texas 75265  
Copyright © 2021, 德州仪器 (TI) 公司

**PACKAGING INFORMATION**

Orderable Device	Status (1)	Package Type	Package Drawing	Pins	Package Qty	Eco Plan (2)	Lead finish/ Ball material (6)	MSL Peak Temp (3)	Op Temp (°C)	Device Marking (4/5)	Samples
TPS25830QCWRHBRQ1	ACTIVE	VQFN	RHB	32	5000	RoHS & Green	NIPDAU	Level-2-260C-1 YEAR	-40 to 125	T25830	<a href="#">Samples</a>
TPS25830QWRHBRQ1	ACTIVE	VQFN	RHB	32	3000	RoHS & Green	SN	Level-2-260C-1 YEAR	-40 to 125	T25830	<a href="#">Samples</a>
TPS25830QWRHBTQ1	ACTIVE	VQFN	RHB	32	250	RoHS & Green	SN	Level-2-260C-1 YEAR	-40 to 125	T25830	<a href="#">Samples</a>
TPS25831QCWRHBRQ1	ACTIVE	VQFN	RHB	32	5000	RoHS & Green	NIPDAU	Level-2-260C-1 YEAR	-40 to 125	T25831	<a href="#">Samples</a>
TPS25831QWRHBRQ1	ACTIVE	VQFN	RHB	32	3000	RoHS & Green	SN	Level-2-260C-1 YEAR	-40 to 125	T25831	<a href="#">Samples</a>
TPS25831QWRHBTQ1	ACTIVE	VQFN	RHB	32	250	RoHS & Green	SN	Level-2-260C-1 YEAR	-40 to 125	T25831	<a href="#">Samples</a>

(1) The marketing status values are defined as follows:

**ACTIVE:** Product device recommended for new designs.

**LIFEBUY:** TI has announced that the device will be discontinued, and a lifetime-buy period is in effect.

**NRND:** Not recommended for new designs. Device is in production to support existing customers, but TI does not recommend using this part in a new design.

**PREVIEW:** Device has been announced but is not in production. Samples may or may not be available.

**OBSOLETE:** TI has discontinued the production of the device.

(2) **RoHS:** TI defines "RoHS" to mean semiconductor products that are compliant with the current EU RoHS requirements for all 10 RoHS substances, including the requirement that RoHS substance do not exceed 0.1% by weight in homogeneous materials. Where designed to be soldered at high temperatures, "RoHS" products are suitable for use in specified lead-free processes. TI may reference these types of products as "Pb-Free".

**RoHS Exempt:** TI defines "RoHS Exempt" to mean products that contain lead but are compliant with EU RoHS pursuant to a specific EU RoHS exemption.

**Green:** TI defines "Green" to mean the content of Chlorine (Cl) and Bromine (Br) based flame retardants meet JS709B low halogen requirements of <=1000ppm threshold. Antimony trioxide based flame retardants must also meet the <=1000ppm threshold requirement.

(3) MSL, Peak Temp. - The Moisture Sensitivity Level rating according to the JEDEC industry standard classifications, and peak solder temperature.

(4) There may be additional marking, which relates to the logo, the lot trace code information, or the environmental category on the device.

(5) Multiple Device Markings will be inside parentheses. Only one Device Marking contained in parentheses and separated by a "~" will appear on a device. If a line is indented then it is a continuation of the previous line and the two combined represent the entire Device Marking for that device.

(6) Lead finish/Ball material - Orderable Devices may have multiple material finish options. Finish options are separated by a vertical ruled line. Lead finish/Ball material values may wrap to two lines if the finish value exceeds the maximum column width.

**Important Information and Disclaimer:** The information provided on this page represents TI's knowledge and belief as of the date that it is provided. TI bases its knowledge and belief on information provided by third parties, and makes no representation or warranty as to the accuracy of such information. Efforts are underway to better integrate information from third parties. TI has taken and continues to take reasonable steps to provide representative and accurate information but may not have conducted destructive testing or chemical analysis on incoming materials and chemicals. TI and TI suppliers consider certain information to be proprietary, and thus CAS numbers and other limited information may not be available for release.

In no event shall TI's liability arising out of such information exceed the total purchase price of the TI part(s) at issue in this document sold by TI to Customer on an annual basis.

**TAPE AND REEL INFORMATION**

**QUADRANT ASSIGNMENTS FOR PIN 1 ORIENTATION IN TAPE**

\*All dimensions are nominal

Device	Package Type	Package Drawing	Pins	SPQ	Reel Diameter (mm)	Reel Width W1 (mm)	A0 (mm)	B0 (mm)	K0 (mm)	P1 (mm)	W (mm)	Pin1 Quadrant
TPS25830QCWRHBRQ1	VQFN	RHB	32	5000	330.0	12.4	5.3	5.3	1.1	8.0	12.0	Q2
TPS25830QWRHBRQ1	VQFN	RHB	32	3000	330.0	12.4	5.25	5.25	1.1	8.0	12.0	Q2
TPS25830QWRHBTQ1	VQFN	RHB	32	250	180.0	12.4	5.25	5.25	1.1	8.0	12.0	Q2
TPS25831QCWRHBRQ1	VQFN	RHB	32	5000	330.0	12.4	5.3	5.3	1.1	8.0	12.0	Q2
TPS25831QWRHBRQ1	VQFN	RHB	32	3000	330.0	12.4	5.25	5.25	1.1	8.0	12.0	Q2
TPS25831QWRHBTQ1	VQFN	RHB	32	250	180.0	12.4	5.25	5.25	1.1	8.0	12.0	Q2

## TAPE AND REEL BOX DIMENSIONS



\*All dimensions are nominal

Device	Package Type	Package Drawing	Pins	SPQ	Length (mm)	Width (mm)	Height (mm)
TPS25830QCWRHBRQ1	VQFN	RHB	32	5000	367.0	367.0	35.0
TPS25830QWRHBRQ1	VQFN	RHB	32	3000	367.0	367.0	38.0
TPS25830QWRHBTQ1	VQFN	RHB	32	250	213.0	191.0	35.0
TPS25831QCWRHBRQ1	VQFN	RHB	32	5000	367.0	367.0	35.0
TPS25831QWRHBRQ1	VQFN	RHB	32	3000	367.0	367.0	38.0
TPS25831QWRHBTQ1	VQFN	RHB	32	250	213.0	191.0	35.0

## GENERIC PACKAGE VIEW

**RHB 32**

**VQFN - 1 mm max height**

5 x 5, 0.5 mm pitch

PLASTIC QUAD FLATPACK - NO LEAD

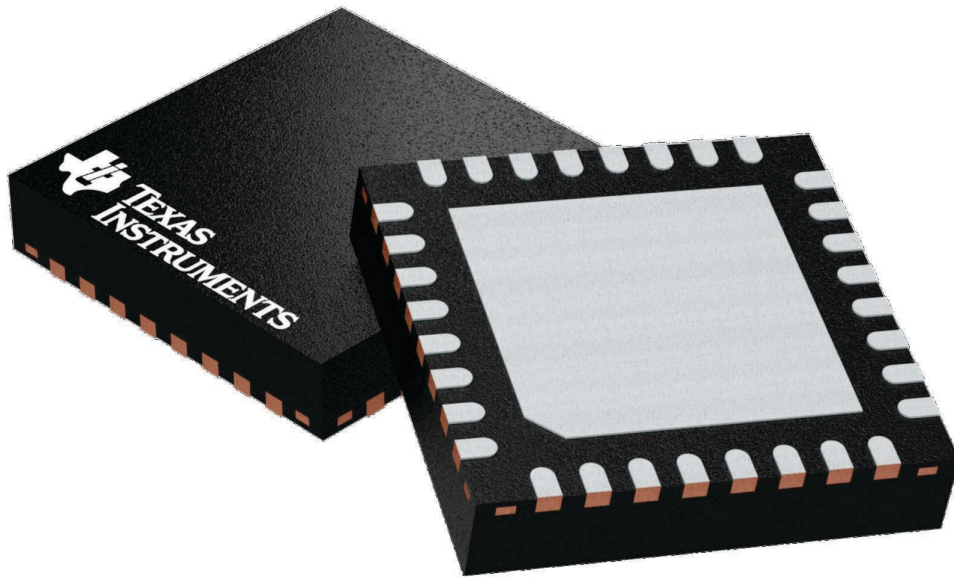

Images above are just a representation of the package family, actual package may vary.  
Refer to the product data sheet for package details.

4224745/A

RHB0032R

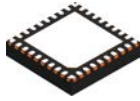

PACKAGE OUTLINE

VQFN - 1 mm max height

PLASTIC QUAD FLATPACK - NO LEAD

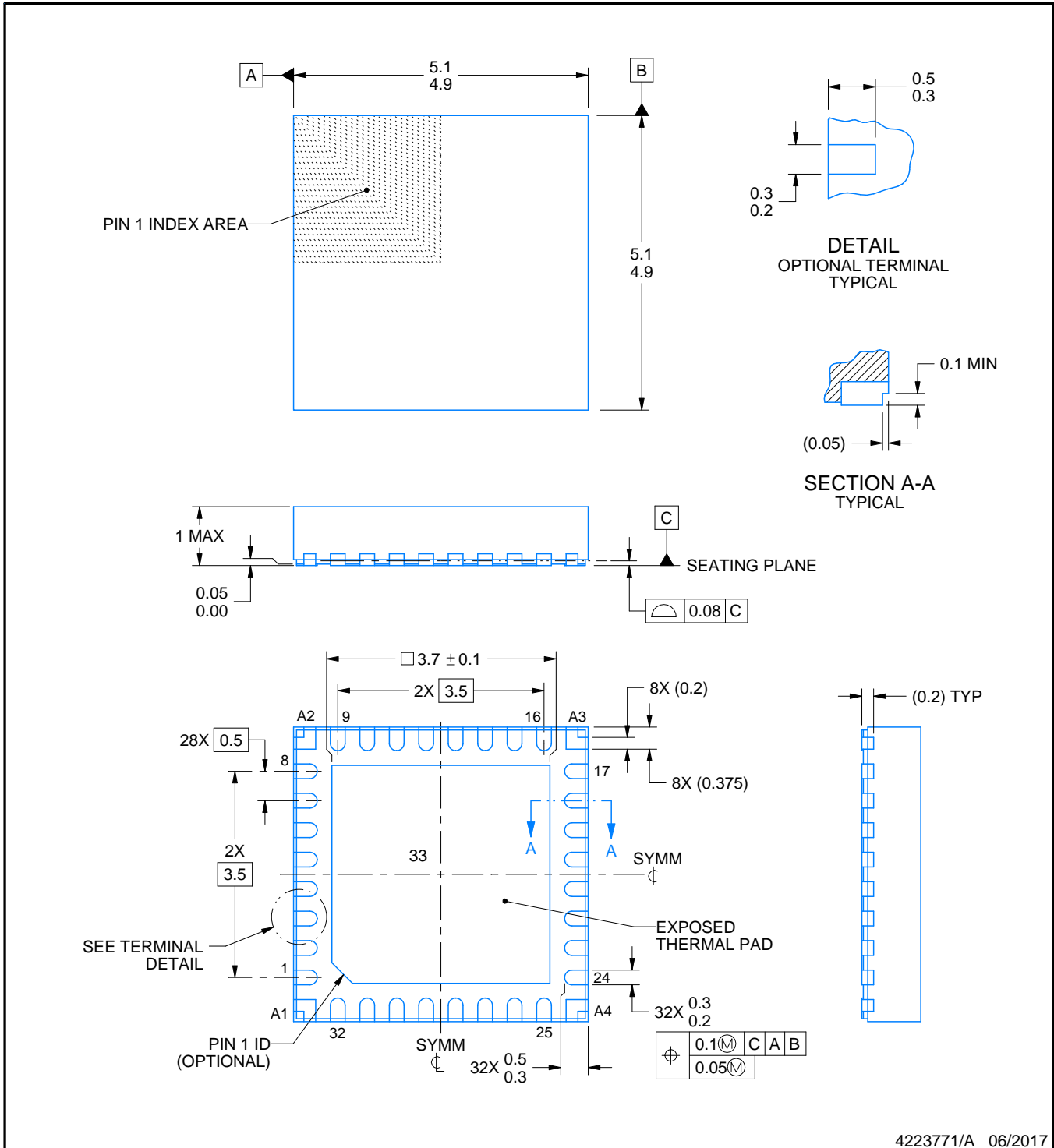

4223771/A 06/2017

NOTES:

1. All linear dimensions are in millimeters. Any dimensions in parenthesis are for reference only. Dimensioning and tolerancing per ASME Y14.5M.
2. This drawing is subject to change without notice.
3. The package thermal pad must be soldered to the printed circuit board for thermal and mechanical performance.

# EXAMPLE BOARD LAYOUT

RHB0032R

VQFN - 1 mm max height

PLASTIC QUAD FLATPACK - NO LEAD

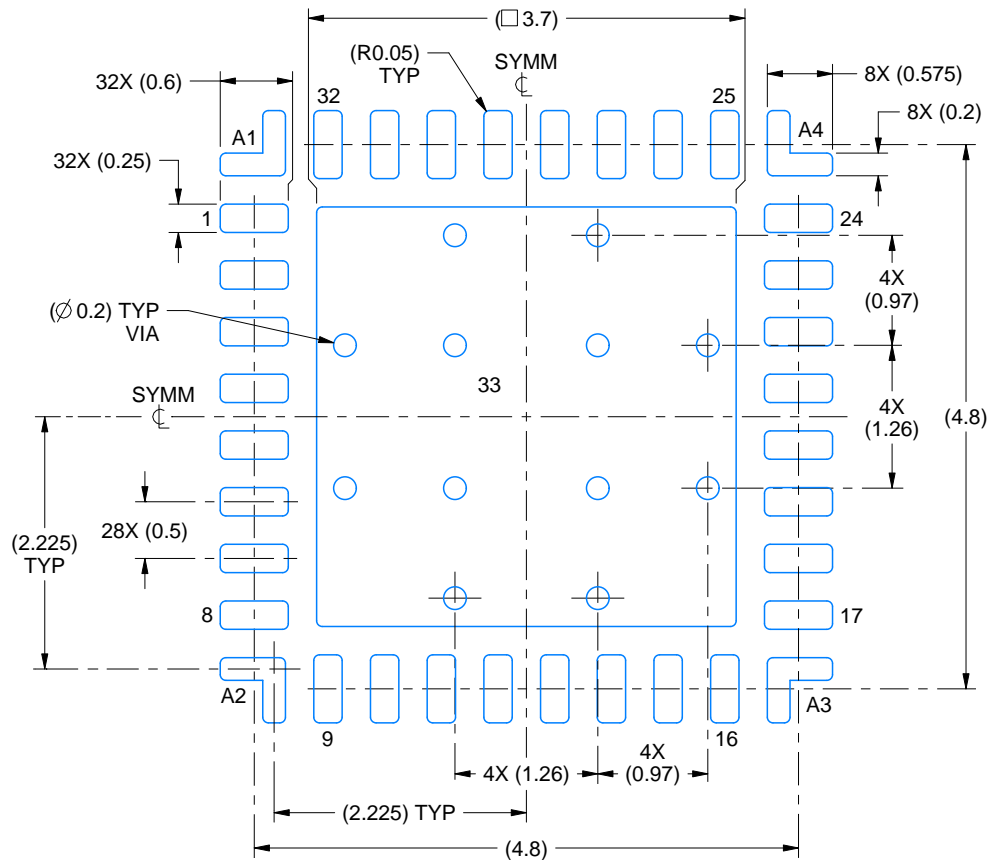

LAND PATTERN EXAMPLE  
EXPOSED METAL SHOWN  
SCALE:15X

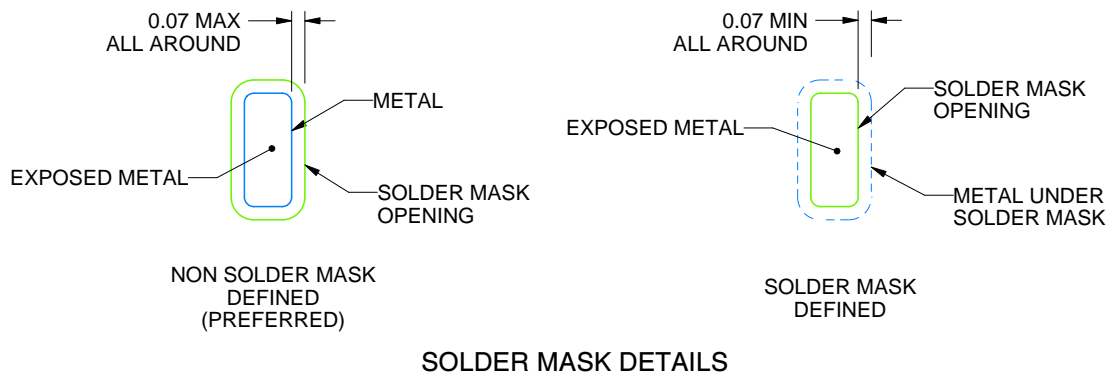

4223771/A 06/2017

NOTES: (continued)

- This package is designed to be soldered to a thermal pad on the board. For more information, see Texas Instruments literature number SLUA271 ([www.ti.com/lit/slua271](http://www.ti.com/lit/slua271)).
- Vias are optional depending on application, refer to device data sheet. If any vias are implemented, refer to their locations shown on this view. It is recommended that vias under paste be filled, plugged or tented.

# EXAMPLE STENCIL DESIGN

RHB0032R

VQFN - 1 mm max height

PLASTIC QUAD FLATPACK - NO LEAD

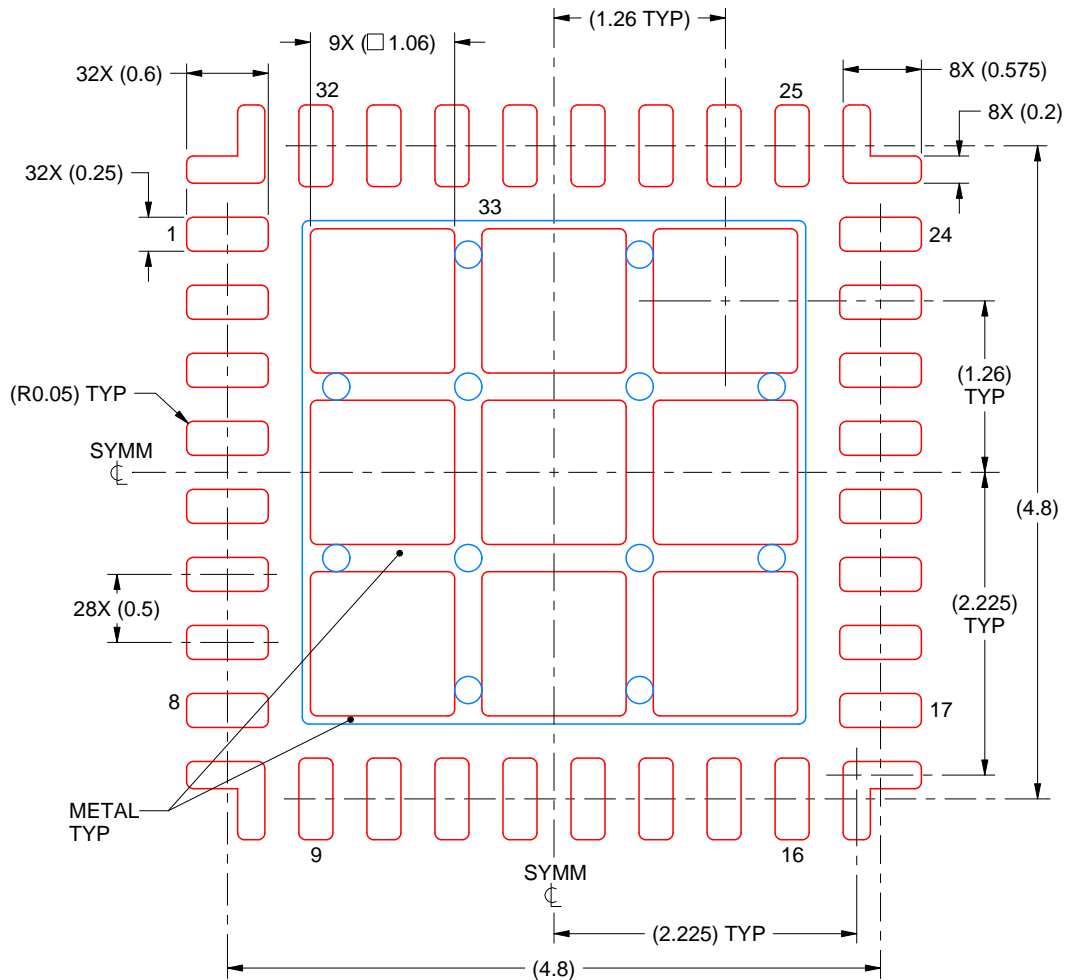

**SOLDER PASTE EXAMPLE**  
BASED ON 0.125 mm THICK STENCIL

EXPOSED PAD 33  
74% PRINTED SOLDER COVERAGE BY AREA UNDER PACKAGE  
SCALE:18X

4223771/A 06/2017

NOTES: (continued)

6. Laser cutting apertures with trapezoidal walls and rounded corners may offer better paste release. IPC-7525 may have alternate design recommendations.

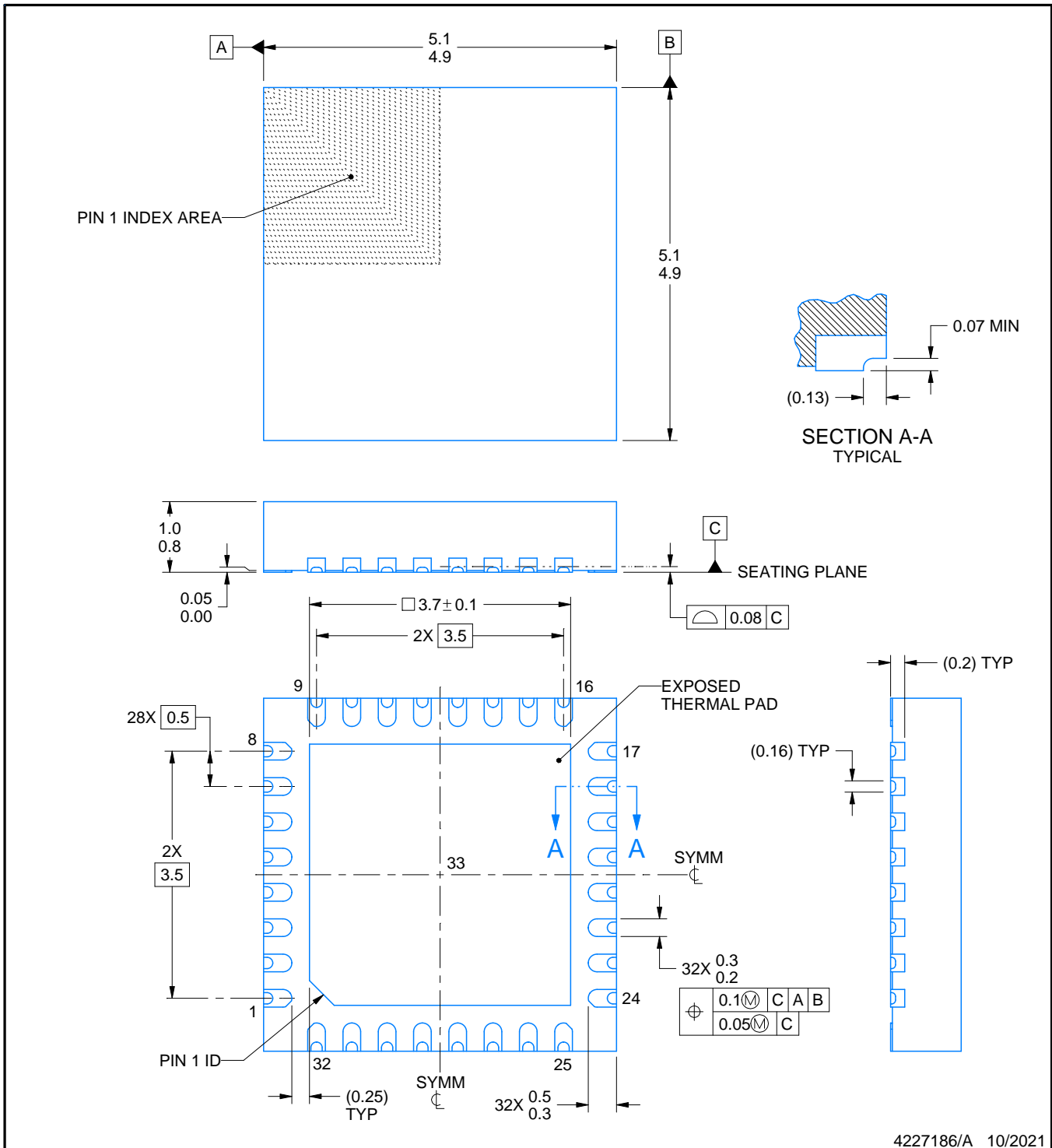
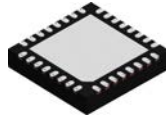

4227186/A 10/2021

NOTES:

1. All linear dimensions are in millimeters. Any dimensions in parenthesis are for reference only. Dimensioning and tolerancing per ASME Y14.5M.
2. This drawing is subject to change without notice.
3. The package thermal pad must be soldered to the printed circuit board for thermal and mechanical performance.

# EXAMPLE BOARD LAYOUT

RHB0032AA

VQFN - 1 mm max height

PLASTIC QUAD FLATPACK - NO LEAD

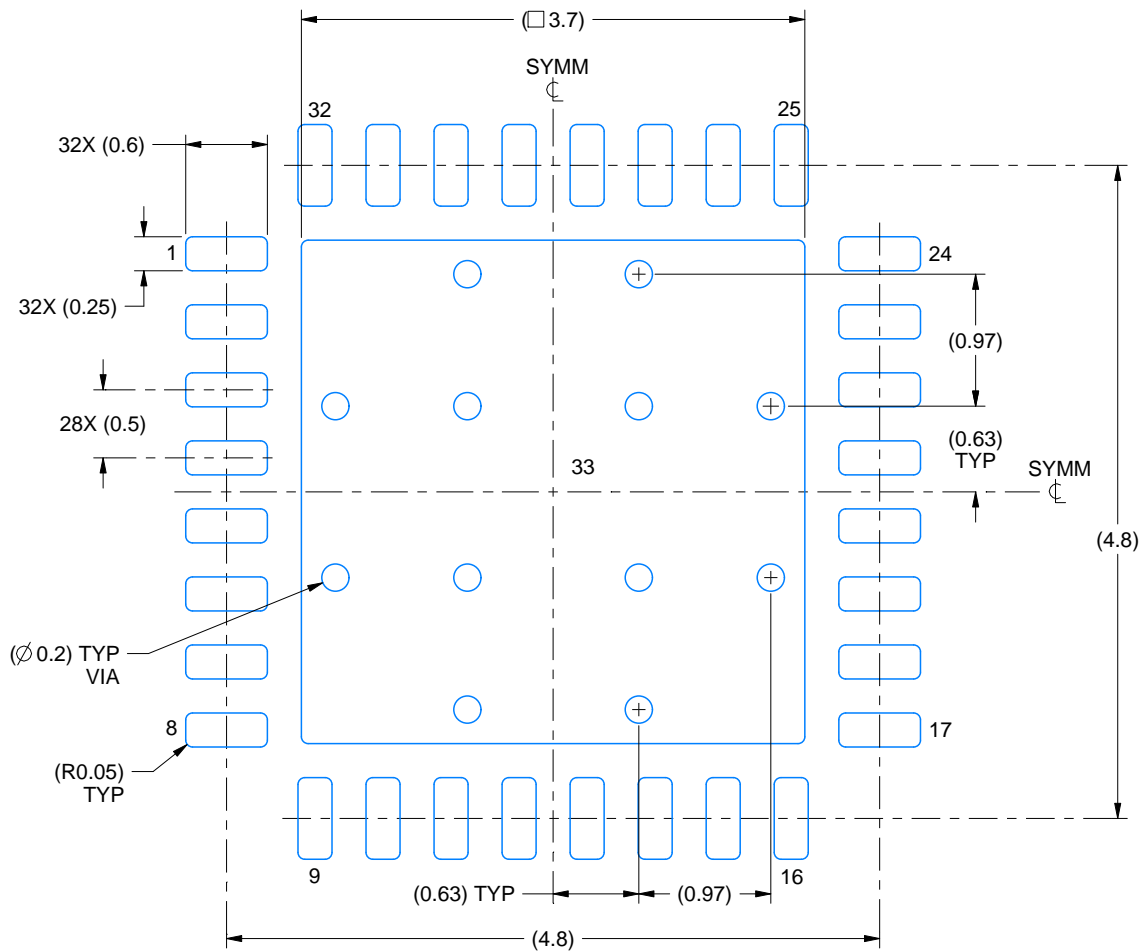

LAND PATTERN EXAMPLE  
EXPOSED METAL SHOWN  
SCALE:18X

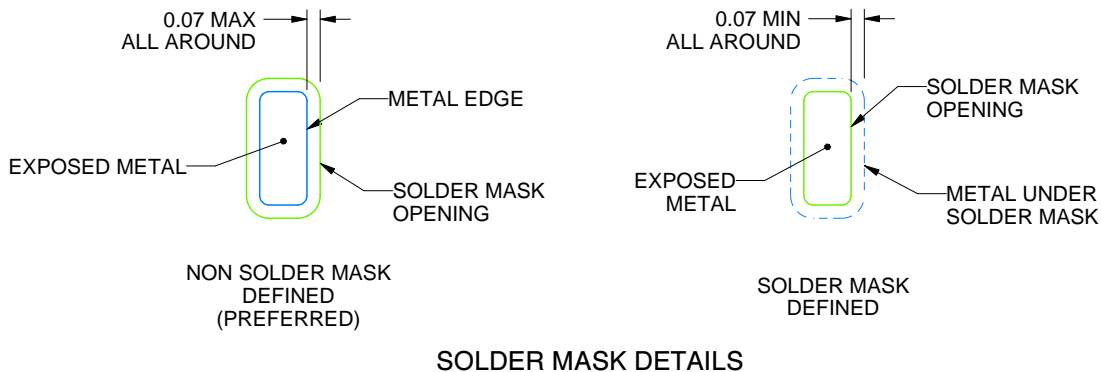

SOLDER MASK DETAILS

4227186/A 10/2021

NOTES: (continued)

- This package is designed to be soldered to a thermal pad on the board. For more information, see Texas Instruments literature number SLUA271 ([www.ti.com/lit/slua271](http://www.ti.com/lit/slua271)).
- Vias are optional depending on application, refer to device data sheet. If any vias are implemented, refer to their locations shown on this view. It is recommended that vias under paste be filled, plugged or tented.

# EXAMPLE STENCIL DESIGN

RHB0032AA

VQFN - 1 mm max height

PLASTIC QUAD FLATPACK - NO LEAD

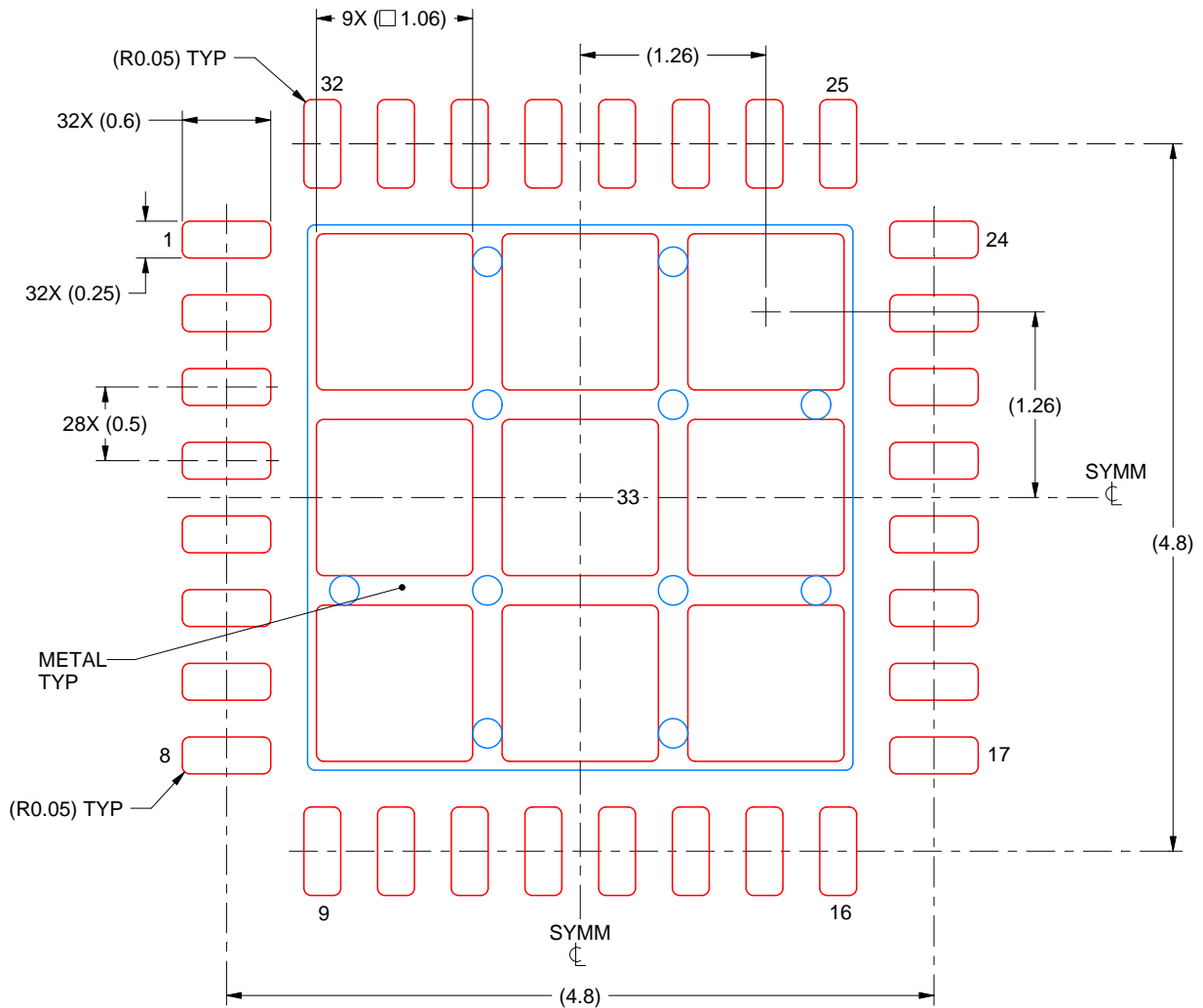

**SOLDER PASTE EXAMPLE**  
 BASED ON 0.125 mm THICK STENCIL

EXPOSED PAD 33:  
 74% PRINTED SOLDER COVERAGE BY AREA UNDER PACKAGE  
 SCALE:20X

4227186/A 10/2021

NOTES: (continued)

6. Laser cutting apertures with trapezoidal walls and rounded corners may offer better paste release. IPC-7525 may have alternate design recommendations.

## 重要声明和免责声明

TI“按原样”提供技术和可靠性数据（包括数据表）、设计资源（包括参考设计）、应用或其他设计建议、网络工具、安全信息和其他资源，不保证没有瑕疵且不做任何明示或暗示的担保，包括但不限于对适销性、某特定用途方面的适用性或不侵犯任何第三方知识产权的暗示担保。

这些资源可供使用 TI 产品进行设计的熟练开发人员使用。您将自行承担以下全部责任：(1) 针对您的应用选择合适的 TI 产品，(2) 设计、验证并测试您的应用，(3) 确保您的应用满足相应标准以及任何其他功能安全、信息安全、监管或其他要求。

这些资源如有变更，恕不另行通知。TI 授权您仅可将这些资源用于研发本资源所述的 TI 产品的应用。严禁对这些资源进行其他复制或展示。您无权使用任何其他 TI 知识产权或任何第三方知识产权。您应全额赔偿因在这些资源的使用中对 TI 及其代表造成的任何索赔、损害、成本、损失和债务，TI 对此概不负责。

TI 提供的产品受 [TI 的销售条款](#) 或 [ti.com](#) 上其他适用条款/TI 产品随附的其他适用条款的约束。TI 提供这些资源并不会扩展或以其他方式更改 TI 针对 TI 产品发布的适用的担保或担保免责声明。

TI 反对并拒绝您可能提出的任何其他或不同的条款。

邮寄地址：Texas Instruments, Post Office Box 655303, Dallas, Texas 75265

Copyright © 2022，德州仪器 (TI) 公司