

TPS548D22 1.5V 至 16V V_{IN} 、4.5V 至 22V V_{DD} 、40A 且具有全差分感应功能的 SWIFT™ 同步降压转换器

1 特性

- 转换输入电压范围 (PV_{IN}): 1.5V 至 16V
- 输入偏置电压 (V_{DD}) 范围: 4.5V 至 22V
- 输出电压范围: 0.6V 至 5.5V
- 集成式 2.9m Ω 和 1.2m Ω 功率 MOSFET, 持续输出电流为 40A
- 电压基准 0.6V 至 1.2V (阶跃为 50mV), 采用 VSEL 引脚
- $\pm 0.5\%$, 0.9V_{REF} 公差范围: -40°C 至 $+125^{\circ}\text{C}$ 结温
- 真正的差分遥感放大器
- D-CAP3™ 控制环路, 可在不使用外部补偿的情况下支持大容量电容器和/或小型 MLCC
- 自适应导通时间控制, 具有 4 种频率设置可供选择: 425kHz、650kHz、875kHz 和 1.05MHz
- 温度补偿和可编程电流限值, 具有 R_{ILIM} 和 OC 钳位
- 可选断续或闭锁 OVP 或 UVP
- 通过精确的 EN 迟滞实现的 VDD UVLO 外部调整
- 预偏置启动支持
- Eco-mode™ 和 FCCM 可供选择
- 全套故障保护和 PGOOD
- 7mm × 5mm × 1.5mm、40 引脚、堆叠削波式 LQFN-CLIP 封装

2 应用

- 企业级存储、SSD、NAS
- 无线和有线通信基础设施
- 工业 PC、自动化、ATE、PLC、视频监控
- 企业服务器、交换机、路由器
- ASIC、SoC、FPGA、DSP 内核和 I/O 电源轨

3 说明

TPS548D22 器件是一款紧凑型单通道降压转换器, 具有自适应导通时间 D-CAP3 模式控制。该器件专为高精度、高效率、快速瞬态响应、易于使用、外部组件较少且空间受限的电源系统而设计。

该器件采用全差分感应和 TI 集成 FET, 高侧导通电阻为 2.9m Ω , 低侧导通电阻为 1.2m Ω 。此外, 该器件还具有 0.5% 的精度和 0.9V 基准电压, 环境温度范围介于 -40°C 和 $+125^{\circ}\text{C}$ 之间。具有竞争力的特性包括: 极少的外部组件数、精确的负载调节和线路调节、自动跳跃或 FCCM 工作模式以及内部软启动控制。

TPS548D22 器件采用 7mm × 5mm、40 引脚、LQFN-CLIP (RVF) 封装 (RoHs 豁免)。

器件信息⁽¹⁾

器件型号	封装	封装尺寸 (标称值)
TPS548D22	LQFN-CLIP (40)	7.00mm × 5.00mm

(1) 如需了解所有可用封装, 请参阅数据表末尾的可订购产品附录。

简化应用

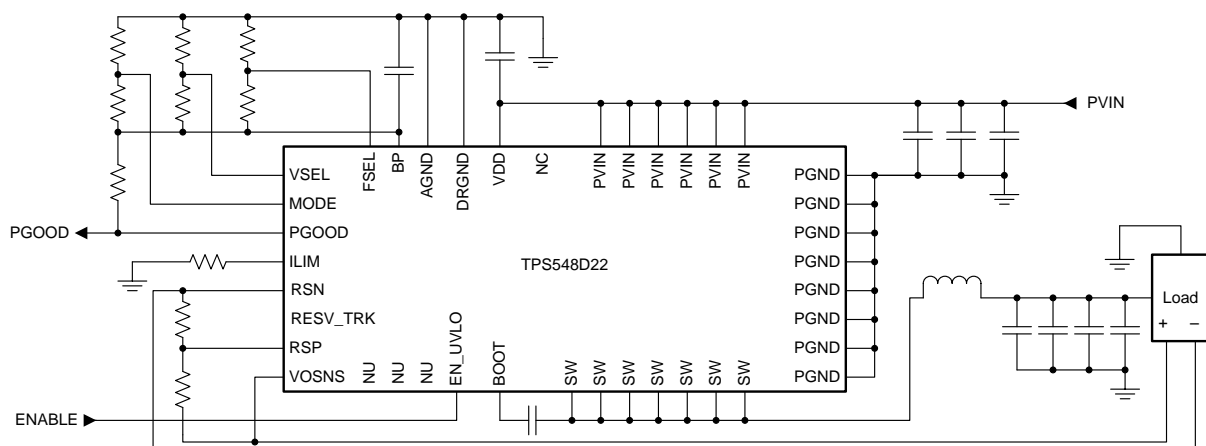

Copyright © 2016, Texas Instruments Incorporated



目录

1	特性	1	7.5	Programming.....	15
2	应用	1	8	Application and Implementation	21
3	说明	1	8.1	Application Information.....	21
4	修订历史记录	2	8.2	Typical Applications	22
5	Pin Configuration and Functions	3	9	Power Supply Recommendations	32
6	Specifications	4	10	Layout	32
6.1	Absolute Maximum Ratings	4	10.1	Layout Guidelines	32
6.2	ESD Ratings.....	4	10.2	Layout Example	33
6.3	Recommended Operating Conditions.....	4	11	器件和文档支持	36
6.4	Thermal Information	5	11.1	器件支持	36
6.5	Electrical Characteristics.....	5	11.2	接收文档更新通知	36
6.6	Typical Characteristics	9	11.3	社区资源.....	36
7	Detailed Description	11	11.4	商标.....	36
7.1	Overview	11	11.5	静电放电警告.....	36
7.2	Functional Block Diagram	11	11.6	Glossary	36
7.3	Feature Description.....	12	12	机械、封装和可订购信息.....	36
7.4	Device Functional Modes.....	15	12.1	Package Option Addendum	37

4 修订历史记录

注：之前版本的页码可能与当前版本有所不同。

Changes from Revision C (September 2016) to Revision D	Page
• Added MIN and MAX values for VDD UVLO rising threshold.....	5
• Added MIN and MAX for all Soft Start settings and table notes 3 and 4 in Electrical Characteristics	7
• Changed $V_{OUT} = 5\text{ V}$ to $V_{OUT} = 5.5\text{ V}$ for Figure 13	12
• Added notes for 8 ms and 4 ms in Table 4 ; added Application Workaround to Support 4-ms and 8-ms SS Settings	18
• Added Figure 16 and Figure 17	18
• Changed ...minimum output capacitance calculated from "286 μF " to "28.6 μF ".....	26
• Changed "1.6 μs " to "1.538 μs "; "150 ns" to "300 ns" and "963 μF " to "969 μF ".....	27

Changes from Revision B (May 2016) to Revision C	Page
• Added t_{PODLY} Power-on delay, spec; changed t_{PGDLY} , Delay for PGOOD going in TYP from 1 to 1.024 ms	7
• Changed Typical Application Schematic	22
• Changed Equation 2	24
• Added missing hyper link to table reference, and corrected typo error.....	29
• 已添加 Tape and Reel Information	38

Changes from Revision A (April 2016) to Revision B	Page
• Restored original FSEL Pin Strap Configurations table that was inadvertently changed during editing for Revision A.	16
• Changed Equation 8 for clarification.....	26
• Changed text string in MODE Pin Selection description From: "... $R_{MODE(LS)}$ of 22.1 k Ω .." To: " $R_{MODE(LS)}$ of 42.2 k Ω .." ...	29

Changes from Original (March 2016) to Revision A	Page
• 已更改 将数据表状态从预览 更改成了生产.....	1

5 Pin Configuration and Functions

RVF Package
40-Pin LQFN-CLIP With Thermal Pad
Top View

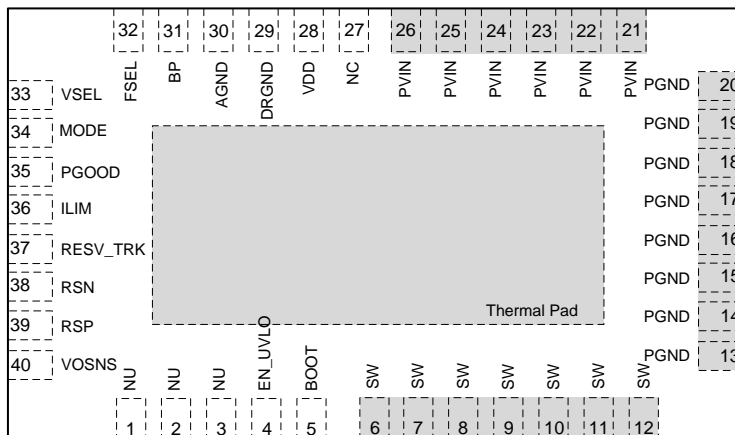

Pin Functions

PIN		I/O/P ⁽¹⁾	DESCRIPTION
NAME	NO.		
AGND	30	G	Ground pin for internal analog circuits.
BOOT	5	P	Supply rail for high-side gate driver (boot terminal). Connect boot capacitor from this pin to SW node. Internally connected to BP via bootstrap PMOS switch.
BP	31	O	LDO output
DRGND	29	P	Internal gate driver return.
EN_UVLO	4	I	Enable pin that can turn on the DC/DC switching converter. Use also to program the required PVIN UVLO when PVIN and VDD are connected together.
FSEL	32	I	Program switching frequency, internal ramp amplitude and SKIP or FCCM mode.
ILIM	36	I/O	Program overcurrent limit by connecting a resistor to ground.
MODE	34	I	Mode selection pin. Select the control mode (DCAP3 or DCAP), internal VREF operation, and soft-start timing selection.
NC	27		No connect.
NU	1, 2, 3	O	Not used pins.
PGND	13, 14, 15, 16, 17, 18, 19, 20	P	Power ground of internal FETs.
PGOOD	35	O	Open drain power good status signal.
PVIN	21, 22, 23, 24, 25, 26	P	Power supply input for integrated power MOSFET pair.
RSN	38	I	Inverting input of the differential remote sense amplifier.
RSP	39	I	Non-inverting input of the differential remote sense amplifier.
RESV_TRK	37	I	Do not connect.
SW	6, 7, 8, 9, 10, 11, 12	I/O	Output switching terminal of power converter. Connect the pins to the output inductor.
VDD	28	P	Controller power supply input.
VOSNS	40	I	Output voltage monitor input pin.
VSEL	33	I	Program the initial start-up and or reference voltage without feedback resistor dividers (from 0.6 V to 1.2 V in 50-mV increments).

(1) I = input, O = output, G = GND

6 Specifications

6.1 Absolute Maximum Ratings

 over operating free-air temperature range (unless otherwise noted) ⁽¹⁾⁽²⁾

		MIN	MAX	UNIT	
Input voltage	PVIN	-0.3	25	V	
	VDD	-0.3	25		
	BOOT	-0.3	34		
	BOOT to SW	DC	-0.3		7.7
		< 10 ns	-0.3		9.0
	NU	-0.3	6		
	EN_UVLO, VOSNS, MODE, FSEL, ILIM	-0.3	7.7		
	RSP, RESV_TRK, VSEL	-0.3	3.6		
	RSN	-0.3	0.3		
	PGND, AGND, DRGND	-0.3	0.3		
	SW	DC	-0.3		25
< 10 ns		-5	27		
Output voltage	PGOOD, BP	-0.3	7.7	V	
Junction temperature, T _J		-55	150	°C	
Storage temperature, T _{stg}		-55	150	°C	

- (1) Stresses beyond those listed under *Absolute Maximum Ratings* may cause permanent damage to the device. These are stress ratings only, which do not imply functional operation of the device at these or any other conditions beyond those indicated under *Recommended Operating Conditions*. Exposure to absolute-maximum-rated conditions for extended periods may affect device reliability.
- (2) All voltage values are with respect to the network ground terminal unless otherwise noted.

6.2 ESD Ratings

		VALUE	UNIT
V _(ESD)	Electrostatic discharge	Human-body model (HBM), per ANSI/ESDA/JEDEC JS-001 ⁽¹⁾	±2000
		Charged-device model (CDM), per JEDEC specification JESD22-C101 ⁽²⁾	±500

- (1) JEDEC document JEP155 states that 500-V HBM allows safe manufacturing with a standard ESD control process.
- (2) JEDEC document JEP157 states that 250-V CDM allows safe manufacturing with a standard ESD control process.

6.3 Recommended Operating Conditions

over operating free-air temperature range (unless otherwise noted)

		MIN	MAX	UNIT	
Input voltage	PVIN	1.5	16	V	
	VDD	4.5	22		
	BOOT	-0.1	24.5		
	BOOT to SW	DC	-0.1		6.5
		< 10 ns	-0.1		7
	NU	-0.1	5.5		
	EN_UVLO, VOSNS, MODE, FSEL, ILIM	-0.1	5.5		
	RSP, RESV_TRK, VSEL	-0.1	3.3		
	RSN	-0.1	0.1		
	PGND, AGND, DRGND	-0.1	0.1		
	SW	DC	-0.1		18
< 10 ns		-5	27		
Output voltage	PGOOD, BP	-0.1	7	V	
Junction temperature, T _J		-40	125	°C	

6.4 Thermal Information

THERMAL METRIC ⁽¹⁾		TPS548D22	UNIT
		RVF (LQFN-CLIP)	
		(40 PINS)	
R _{θJA}	Junction-to-ambient thermal resistance	28.5	°C/W
R _{θJC(top)}	Junction-to-case (top) thermal resistance	18.3	°C/W
R _{θJB}	Junction-to-board thermal resistance	3.6	°C/W
ψ _{JT}	Junction-to-top characterization parameter	0.96	°C/W
ψ _{JB}	Junction-to-board characterization parameter	3.6	°C/W
R _{θJC(bot)}	Junction-to-case (bottom) thermal resistance	0.6	°C/W

(1) For more information about traditional and new thermal metrics, see the [Semiconductor and IC Package Thermal Metrics](#) application report.

6.5 Electrical Characteristics

over operating free-air temperature range, V_{VDD} = 12 V, V_{EN_UVLO} = 5 V (unless otherwise noted)

PARAMETER		TEST CONDITION	MIN	TYP	MAX	UNIT
MOSFET ON-RESISTANCE (R_{DS(on)})						
R _{DS(on)}	High-side FET	(V _{BOOT} – V _{SW}) = 5 V, I _D = 25 A, T _J = 25°C		2.9		mΩ
	Low-side FET	V _{VDD} = 5 V, I _D = 25 A, T _J = 25°C		1.2		mΩ
INPUT SUPPLY AND CURRENT						
V _{VDD}	VDD supply voltage	Nominal VDD voltage range	4.5		22	V
I _{VDD}	VDD bias current	No load, power conversion enabled (no switching), T _A = 25°C,		2.0		mA
I _{VDDSTBY}	VDD standby current	No load, power conversion disabled, T _A = 25°C		700		μA
UNDERVOLTAGE LOCKOUT						
V _{VDD_UVLO}	VDD UVLO rising threshold		4.23	4.25	4.34	V
V _{VDD_UVLO(HYS)}	VDD UVLO hysteresis			0.2		V
V _{EN_ON_TH}	EN_UVLO on threshold		1.45	1.6	1.75	V
V _{EN_HYS}	EN_UVLO hysteresis		270	300	340	mV
I _{EN_LKG}	EN_UVLO input leakage current	V _{EN_UVLO} = 5 V	–1	0	1	μA
INTERNAL REFERENCE VOLTAGE AND RANGE						
V _{INTREF}	Internal REF voltage			900.4		mV
V _{INTREFTOL}	Internal REF voltage tolerance	–40°C ≤ T _J ≤ 125°C	–0.5%		0.5%	
V _{INTREF}	Internal REF voltage range		0.6		1.2	V
OUTPUT VOLTAGE						
V _{IOS_LPCMP}	Loop comparator input offset voltage ⁽¹⁾		–2.5		2.5	mV
I _{RSP}	RSP input current	V _{RSP} = 600 mV	–1		1	μA
I _{VO(dis)}	VO discharge current	V _{VO} = 0.5 V, power conversion disabled	8	12		mA
DIFFERENTIAL REMOTE SENSE AMPLIFIER						
f _{UGBW}	Unity gain bandwidth ⁽¹⁾		5	7		MHz
A ₀	Open loop gain ⁽¹⁾		75			dB
SR	Slew rate ⁽¹⁾			±4.7		V/μsec
V _{IRNG}	Input range ⁽¹⁾		–0.2		1.8	V
V _{OFFSET}	Input offset voltage ⁽¹⁾		–3.5		3.5	mV
INTERNAL BOOT STRAP SWITCH						
V _F	Forward voltage	V _{BP-BOOT} , I _F = 10 mA, T _A = 25°C		0.1	0.2	V
I _{BOOT}	VBST leakage current	V _{BOOT} = 30 V, V _{SW} = 25 V, T _A = 25°C		0.01	1.5	μA

(1) Specified by design. Not production tested.

Electrical Characteristics (continued)

over operating free-air temperature range, $V_{DD} = 12\text{ V}$, $V_{EN_UVLO} = 5\text{ V}$ (unless otherwise noted)

PARAMETER		TEST CONDITION	MIN	TYP	MAX	UNIT
SWITCHING FREQUENCY						
f_{SW}	VO switching frequency ⁽²⁾	$V_{IN} = 12\text{ V}$, $V_{VO} = 1\text{ V}$, $T_A = 25^\circ\text{C}$	380	425	475	kHz
			585	650	740	
			790	875	995	
			950	1050	1250	
$t_{ON(min)}$	Minimum on time ⁽¹⁾		60			ns
$t_{OFF(min)}$	Minimum off time ⁽¹⁾	DRVH falling to rising			300	ns
MODE, VSEL, FSEL DETECTION						
V_{DETECT_TH}	MODE, VSEL, and FSEL detection voltage	$V_{BP} = 2.93\text{ V}$, $R_{HIGH} = 100\text{ k}\Omega$	Open	V_{BP}		V
			$R_{LOW} = 187\text{ k}\Omega$	1.9091		
			$R_{LOW} = 165\text{ k}\Omega$	1.8243		
			$R_{LOW} = 147\text{ k}\Omega$	1.7438		
			$R_{LOW} = 133\text{ k}\Omega$	1.6725		
			$R_{LOW} = 121\text{ k}\Omega$	1.6042		
			$R_{LOW} = 110\text{ k}\Omega$	1.5348		
			$R_{LOW} = 100\text{ k}\Omega$	1.465		
			$R_{LOW} = 90.9\text{ k}\Omega$	1.3952		
			$R_{LOW} = 82.5\text{ k}\Omega$	1.3245		
			$R_{LOW} = 75\text{ k}\Omega$	1.2557		
			$R_{LOW} = 68.1\text{ k}\Omega$	1.187		
			$R_{LOW} = 60.4\text{ k}\Omega$	1.1033		
			$R_{LOW} = 53.6\text{ k}\Omega$	1.0224		
			$R_{LOW} = 47.5\text{ k}\Omega$	0.9436		
			$R_{LOW} = 42.2\text{ k}\Omega$	0.8695		
			$R_{LOW} = 37.4\text{ k}\Omega$	0.7975		
			$R_{LOW} = 33.2\text{ k}\Omega$	0.7303		
			$R_{LOW} = 29.4\text{ k}\Omega$	0.6657		
			$R_{LOW} = 25.5\text{ k}\Omega$	0.5953		
			$R_{LOW} = 22.1\text{ k}\Omega$	0.5303		
			$R_{LOW} = 19.1\text{ k}\Omega$	0.4699		
			$R_{LOW} = 16.5\text{ k}\Omega$	0.415		
			$R_{LOW} = 14.3\text{ k}\Omega$	0.3666		
$R_{LOW} = 12.1\text{ k}\Omega$	0.3163					
$R_{LOW} = 10\text{ k}\Omega$	0.2664					
$R_{LOW} = 7.87\text{ k}\Omega$	0.2138					
$R_{LOW} = 6.19\text{ k}\Omega$	0.1708					
$R_{LOW} = 4.64\text{ k}\Omega$	0.1299					
$R_{LOW} = 3.16\text{ k}\Omega$	0.0898					
$R_{LOW} = 1.78\text{ k}\Omega$	0.0512					
$R_{LOW} = 0\ \Omega$	GND					

(2) Correlated with close loop EVM measurement at load current of 30 A.

Electrical Characteristics (continued)

over operating free-air temperature range, $V_{DD} = 12\text{ V}$, $V_{EN_UVLO} = 5\text{ V}$ (unless otherwise noted)

PARAMETER		TEST CONDITION	MIN	TYP	MAX	UNIT	
SOFT START							
t_{SS}	Soft-start time	V_{OUT} rising from 0 V to 95% of final set point, $R_{MODE_HIGH} = 100\text{ k}\Omega$	$R_{MODE_LOW} = 60.4\text{ k}\Omega$	7	8 ⁽³⁾	10	ms
			$R_{MODE_LOW} = 53.6\text{ k}\Omega$	3.6	4 ⁽⁴⁾	5.2	
			$R_{MODE_LOW} = 47.5\text{ k}\Omega$	1.6	2	2.8	
			$R_{MODE_LOW} = 42.2\text{ k}\Omega$	0.8	1	1.6	
POWER-ON DELAY							
t_{PODLY}	Power-on delay time			1.024		ms	
PGOOD COMPARATOR							
V_{PGTH}	PGOOD threshold	PGOOD in from higher	105	108	111	% V_{REF}	
		PGOOD in from lower	89	92	95		
		PGOOD out to higher		120			
		PGOOD out to lower		68			
I_{PG}	PGOOD sink current	$V_{PGOOD} = 0.5\text{ V}$		6.9		mA	
I_{PGLK}	PGOOD leakage current	$V_{PGOOD} = 5\text{ V}$	-1	0	1	μA	
t_{PGDLY}	PGOOD delay time	Delay for PGOOD going in		1.024		ms	
		Delay for PGOOD coming out			2	μs	
CURRENT DETECTION							
V_{ILIM}	V_{ILIM} voltage range	On-resistance ($R_{DS(on)}$) sensing	0.1		1.2	V	
I_{OCL_VA}	Valley current limit threshold	$R_{LIM} = 130\text{ k}\Omega$		40		A	
		OC tolerance		$\pm 10\%$ ⁽⁵⁾			
		$R_{LIM} = 97.6\text{ k}\Omega$		30		A	
		OC tolerance		$\pm 15\%$ ⁽⁵⁾			
		$R_{LIM} = 64.9\text{ k}\Omega$		20		A	
		OC tolerance		$\pm 20\%$			
$I_{OCL_VA_N}$	Negative valley current limit threshold	$R_{LIM} = 130\text{ k}\Omega$		-40		A	
		$R_{LIM} = 97.6\text{ k}\Omega$		-30			
		$R_{LIM} = 64.9\text{ k}\Omega$		-20			
I_{CLMP_LO}	Clamp current at V_{LIM} clamp at lowest	$V_{ILIM_CLMP} = 0.1\text{ V}$, $T_A = 25^\circ\text{C}$		6.25		A	
I_{CLMP_HI}	Clamp current at V_{LIM} clamp at highest	$V_{ILIM_CLMP} = 1.2\text{ V}$, $T_A = 25^\circ\text{C}$		75		A	
V_{ZC}	Zero cross detection offset			0		mV	

(3) In order to use the 8-ms SS setting, follow the steps outlined in *Application Workaround to Support 4-ms and 8-ms SS Settings*.

(4) In order to use the 4-ms SS setting, follow the steps outlined in *Application Workaround to Support 4-ms and 8-ms SS Settings*.

(5) Calculated from 20-A test data. Not production tested.

Electrical Characteristics (continued)

 over operating free-air temperature range, $V_{DD} = 12\text{ V}$, $V_{EN_UVLO} = 5\text{ V}$ (unless otherwise noted)

PARAMETER		TEST CONDITION	MIN	TYP	MAX	UNIT
PROTECTIONS AND OOB						
V_{BPUVLO}	BP UVLO threshold voltage	Wake-up		3.32		V
		Shutdown		3.11		
V_{OVP}	OVP threshold voltage	OVP detect voltage	117%	120%	123%	V_{REF}
t_{OVPDLY}	OVP response time	100-mV over drive			1	μs
V_{UVP}	UVP threshold voltage	UVP detect voltage	65%	68%	71%	V_{REF}
t_{UVPDLY}	UVP delay filter delay time			1		ms
V_{OOB}	OOB threshold voltage			8%		V_{REF}
t_{HICDLY}	Hiccup blanking time	$t_{SS} = 1\text{ ms}$		16		ms
		$t_{SS} = 2\text{ ms}$		24		ms
		$t_{SS} = 4\text{ ms}$		38		ms
		$t_{SS} = 8\text{ ms}$		67		ms
BP VOLTAGE						
V_{BP}	BP LDO output voltage	$V_{IN} = 12\text{ V}$, $0\text{ A} \leq I_{LOAD} \leq 10\text{ mA}$,		5.07		V
V_{BPDO}	BP LDO drop-out voltage	$V_{IN} = 4.5\text{ V}$, $I_{LOAD} = 30\text{ mA}$, $T_A = 25^\circ\text{C}$			365	mV
I_{BPMAX}	BP LDO over-current limit	$V_{IN} = 12\text{ V}$, $T_A = 25^\circ\text{C}$		100		mA
THERMAL SHUTDOWN						
T_{SDN}	Built-In thermal shutdown threshold ⁽¹⁾	Shutdown temperature	155	165		$^\circ\text{C}$
		Hysteresis			30	

6.6 Typical Characteristics

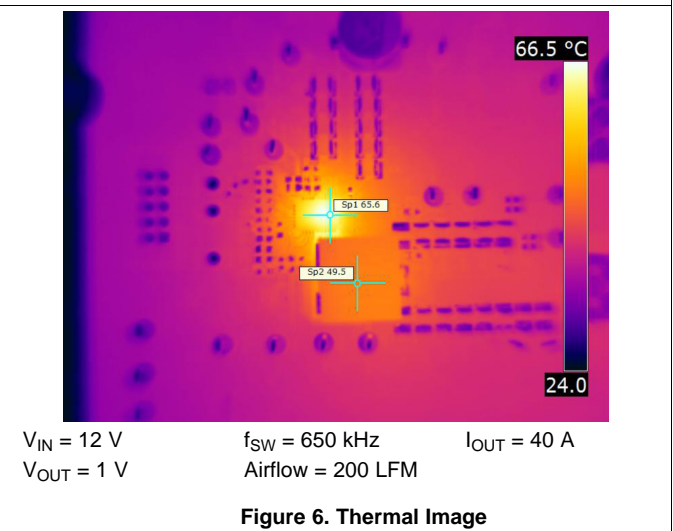
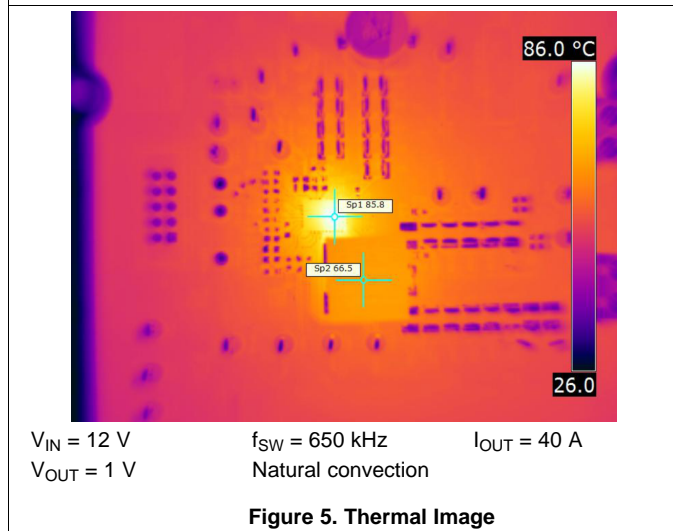
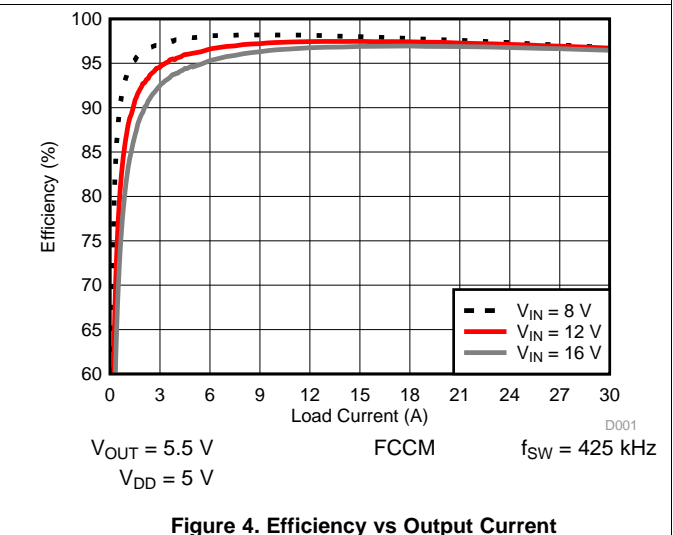
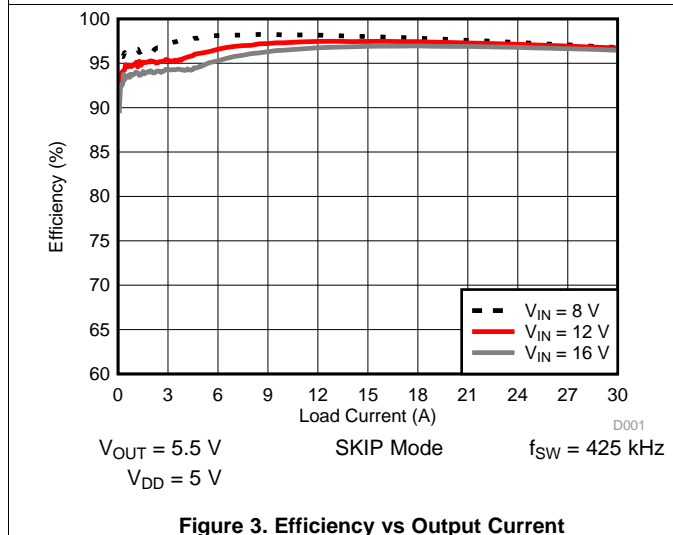
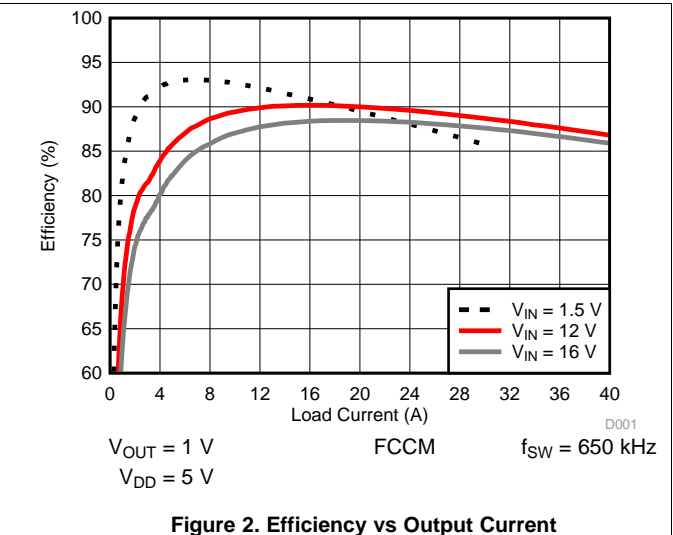
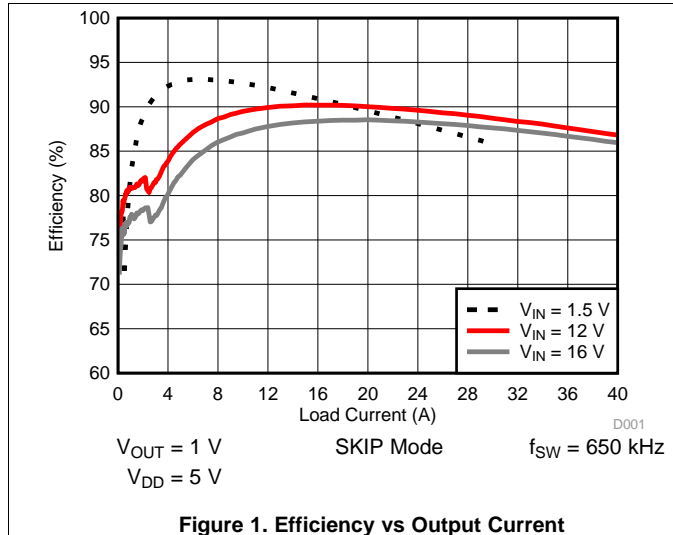

Typical Characteristics (continued)



$V_{IN} = 12\text{ V}$ $f_{SW} = 650\text{ kHz}$ $I_{OUT} = 40\text{ A}$
 $V_{OUT} = 1\text{ V}$ Airflow = 400 LFM

Figure 7. Thermal Image

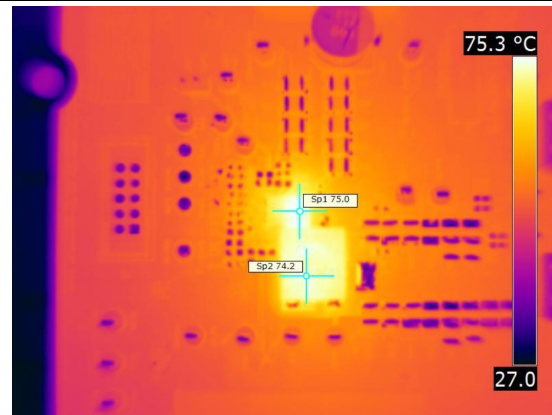

$V_{IN} = 12\text{ V}$ $f_{SW} = 425\text{ kHz}$ $I_{OUT} = 30\text{ A}$
 $V_{OUT} = 5.5\text{ V}$ Natural convection

Figure 8. Thermal Image

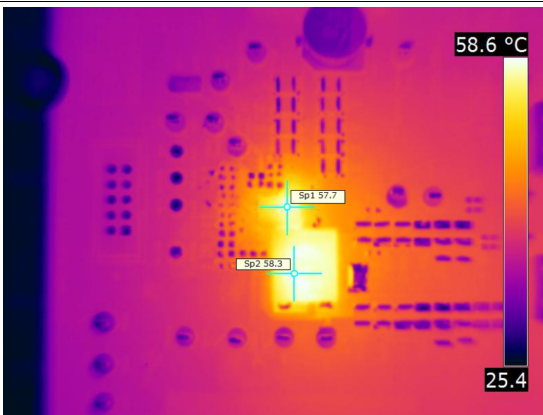

$V_{IN} = 12\text{ V}$ $f_{SW} = 425\text{ kHz}$ $I_{OUT} = 30\text{ A}$
 $V_{OUT} = 5.5\text{ V}$ Airflow = 200 LFM

Figure 9. Thermal Image

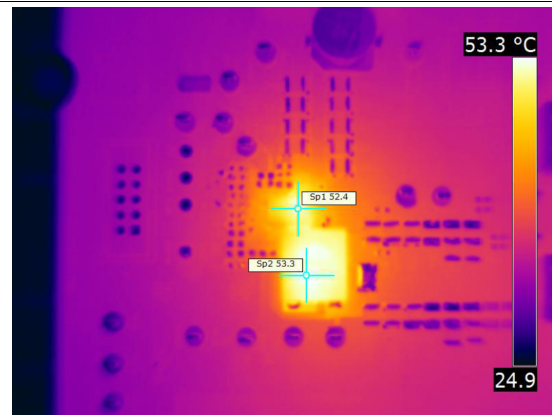

$V_{IN} = 12\text{ V}$ $f_{SW} = 425\text{ kHz}$ $I_{OUT} = 30\text{ A}$
 $V_{OUT} = 5.5\text{ V}$ Airflow = 400 LFM

Figure 10. Thermal Image

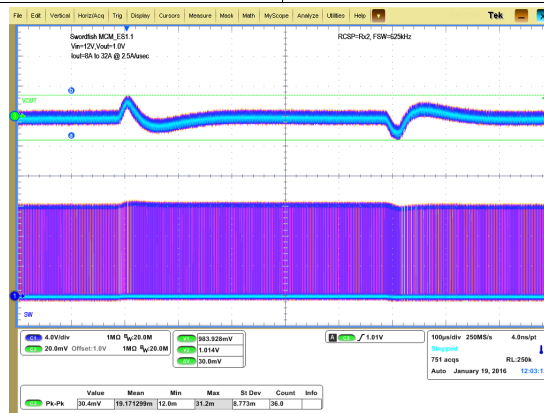

$V_{OUT} = 1\text{ V}$
 I_{OUT} from 8 A to 32 A

Default ramp
 setting

$V_{IN} = 12\text{ V}$
 2.5 A/ μs

Figure 11. Transient Response Peak-to-Peak

7 Detailed Description

7.1 Overview

TPS548D22 device is a high-efficiency, single channel, FET-integrated, synchronous buck converter. It is suitable for point-of-load applications with 40 A or lower output current in storage, telecom and similar digital applications. The device features proprietary D-CAP3 mode control combined with adaptive on-time architecture. This combination is ideal for building modern high/low duty ratio, ultra-fast load step response DC-DC converters.

TPS548D22 device has integrated MOSFETs rated at 40-A TDC.

The converter input voltage range is from 1.5 V up to 16 V, and the VDD input voltage range is from 4.5 V to 22 V. The output voltage ranges from 0.6 V to 5.5 V.

Stable operation with all ceramic output capacitors is supported, since the D-CAP3 mode uses emulated current information to control the modulation. An advantage of this control scheme is that it does not require phase compensation network outside which makes it easy to use and also enables low external component count. The designer selects the switching frequency from 4 preset values via resistor settings by FSEL pin. Adaptive on-time control tracks the preset switching frequency over a wide range of input and output voltage while increasing switching frequency as needed during load step transient.

7.2 Functional Block Diagram

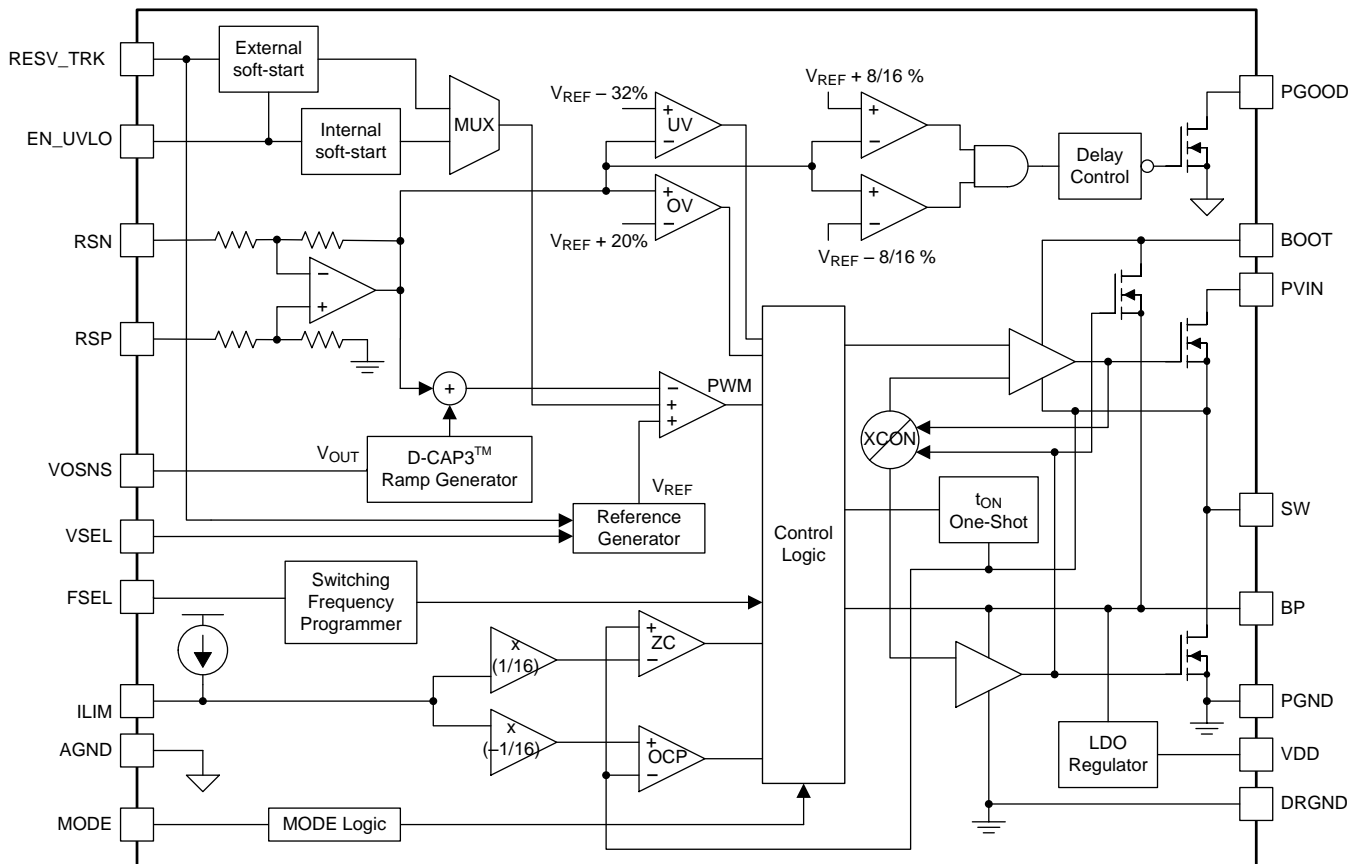

Copyright © 2016, Texas Instruments Incorporated

7.3 Feature Description

7.3.1 40-A FET

The TPS548D22 device is a high-performance, integrated FET converter supporting current rating up to 40 A thermally. It integrates two N-channel NexFET™ power MOSFETs, enabling high power density and small PCB layout area. The drain-to-source breakdown voltage for these FETs is 25 V DC and 27 V transient for 10 ns. Avalanche breakdown occurs if the absolute maximum voltage rating exceeds 27 V. In order to limit the switch node ringing of the device, it is recommended to add a R-C snubber from the SW node to the PGND pins. Refer to the [Layout Guidelines](#) section for the detailed recommendations.

7.3.2 On-Resistance

The typical on-resistance ($R_{DS(on)}$) for the high-side MOSFET is 2.9 mΩ and typical on-resistance for the low-side MOSFET is 1.2 mΩ with a nominal gate voltage (V_{GS}) of 5 V.

7.3.3 Package Size, Efficiency and Thermal Performance

The TPS548D22 device is available in a 5 mm x 7 mm, QFN package with 40 power and I/O pins. It employs TI proprietary MCM packaging technology with thermal pad. With a properly designed system layout, applications achieve optimized safe operating area (SOA) performance. The curves shown in [Figure 12](#) and [Figure 13](#) are based on the orderable evaluation module design. (See [SLUUBE4](#) to order the EVM)

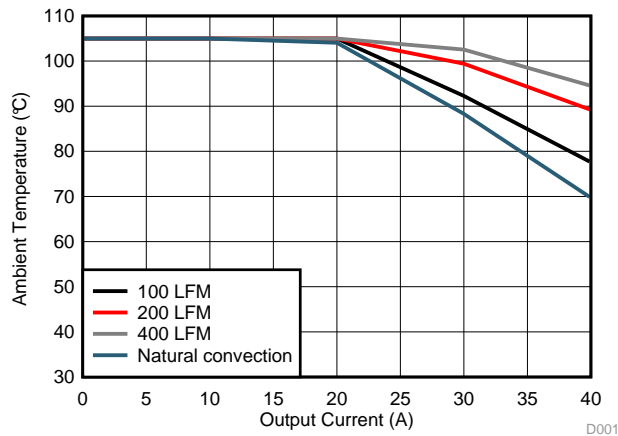

$$V_{IN} = 12 \text{ V} \quad V_{OUT} = 1 \text{ V} \quad f_{SW} = 650 \text{ kHz}$$

Figure 12. Safe Operating Area

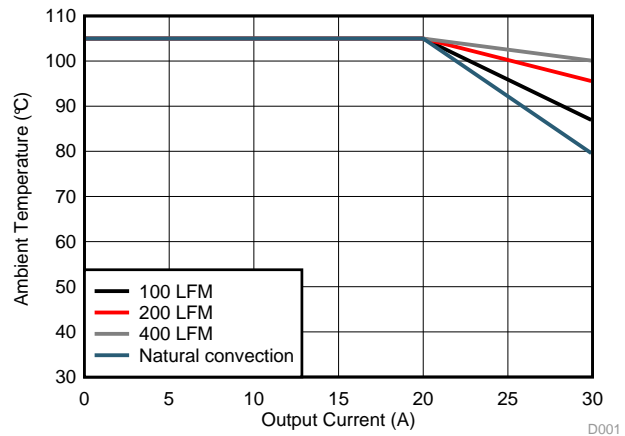

$$V_{IN} = 12 \text{ V} \quad V_{OUT} = V \quad f_{SW} = 425 \text{ kHz}$$

Figure 13. Safe Operating Area

7.3.4 Soft-Start Operation

In the TPS548D22 device the soft-start time controls the inrush current required to charge the output capacitor bank during startup. The device offers selectable soft-start options of 1 ms, 2 ms, 4 ms and 8 ms. When the device is enabled (either by EN or VDD UVLO), the reference voltage ramps from 0 V to the final level defined by VSEL pin strap configuration, in a given soft-start time. The TPS548D22 device supports several soft-start times between 1msec and 8msec selected by MODE pin configuration. Refer to MODE definition table for details.

7.3.5 V_{DD} Supply Undervoltage Lockout (UVLO) Protection

The TPS548D22 device provides fixed VDD undervoltage lockout threshold and hysteresis. The typical VDD turn-on threshold is 4.25 V and hysteresis is 0.2 V. The VDD UVLO can be used in conjunction with the EN_UVLO signal to provide proper power sequence to the converter design. UVLO is a non-latched protection.

7.3.6 EN_UVLO Pin Functionality

The EN_UVLO pin drives an input buffer with accurate threshold and can be used to program the exact required turn-on and turn-off thresholds for switcher enable, VDD UVLO or VIN UVLO (if VIN and VDD are tied together). If desired, an external resistor divider can be used to set and program the turn-on threshold for VDD or VIN UVLO.

Feature Description (continued)

Figure 14 shows how to program the input voltage UVLO using the EN_UVLO pin.

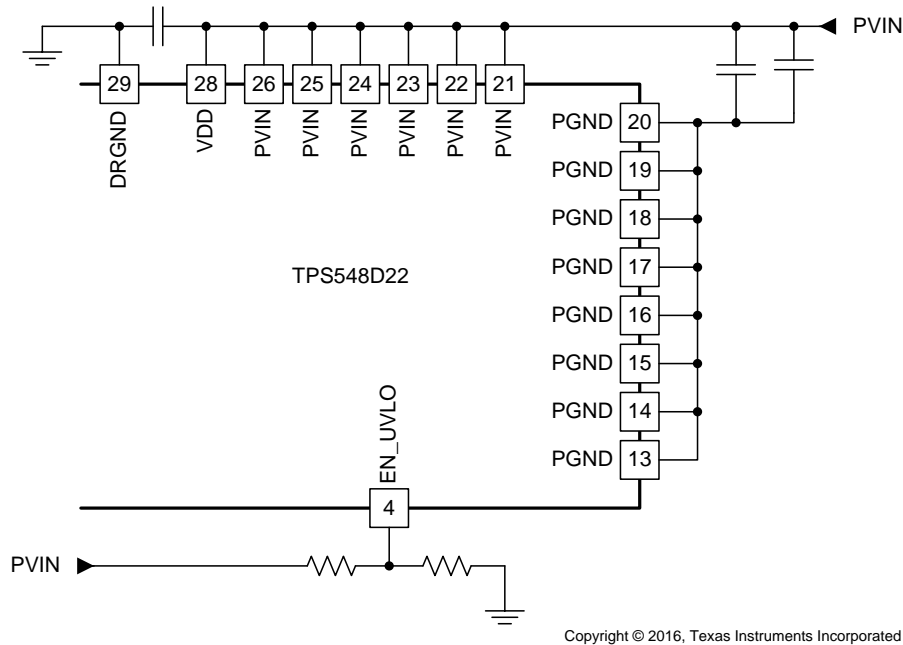

Figure 14. Programming the UVLO Voltage

7.3.7 Fault Protections

This section describes positive and negative overcurrent limits, overvoltage protections, out-of-bounds limits, undervoltage protections and over temperature protections.

7.3.7.1 Current Limit (ILIM) Functionality

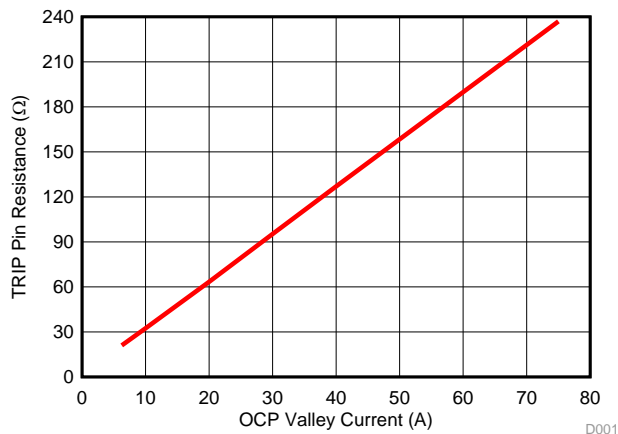

Figure 15. Current Limit Resistance vs OCP Valley Overcurrent Limit

The ILIM pin sets the OCP level. Connect the ILIM pin to GND through the voltage setting resistor, R_{ILIM} . In order to provide both good accuracy and cost effective solution, TPS548D22 device supports temperature compensated internal MOSFET $R_{DS(on)}$ sensing.

Also, the TPS548D22 device performs both positive and negative inductor current limiting with the same magnitudes. The positive current limit normally protects the inductor from saturation that causes damage to the high-side FET and low-side FET. The negative current limit protects the low-side FET during OVP discharge.

Feature Description (continued)

The voltage between GND pin and SW pin during the OFF time monitors the inductor current. The current limit has 3000 ppm/°C temperature slope to compensate the temperature dependency of the on-resistance ($R_{DS(on)}$). The GND pin is used as the positive current sensing node.

TPS548D22 device uses cycle-by-cycle over-current limiting control. The inductor current is monitored during the OFF state and the controller maintains the OFF state during the period that the inductor current is larger than the overcurrent ILIM level. V_{ILIM} sets the valley level of the inductor current.

7.3.7.2 VDD Undervoltage Lockout (UVLO)

The TPS548D22 device has an UVLO protection function for the VDD supply input. The on-threshold voltage is 4.25 V with 200 mV of hysteresis. During a UVLO condition, the device is disabled regardless of the EN_UVLO pin voltage. The supply voltage (V_{VDD}) must be above the on-threshold to begin the pin strap detection.

7.3.7.3 Overvoltage Protection (OVP) and Undervoltage Protection (UVP)

The device monitors a feedback voltage to detect overvoltage and undervoltage. When the feedback voltage becomes lower than 68% of the target voltage, the UVP comparator output goes high and an internal UVP delay counter begins counting. After 1 ms, the device latches OFF both high-side and low-side MOSFETs drivers. The UVP function enables after soft-start is complete.

When the feedback voltage becomes higher than 120% of the target voltage, the OVP comparator output goes high and the circuit latches OFF the high-side MOSFET driver and turns on the low-side MOSFET until reaching a negative current limit. Upon reaching the negative current limit, the low-side FET is turned off and the high-side FET is turned on again for a minimum on-time. The TPS548D22 device operates in this cycle until the output voltage is pulled down under the UVP threshold voltage for 1 ms. After the 1-ms UVP delay time, the high-side FET is latched off and low-side FET is latched on. The fault is cleared with a reset of VDD or by retoggling the EN pin.

Table 1. Overvoltage Protection Details

REFERENCE VOLTAGE (V_{REF})	SOFT-START RAMP	STARTUP OVP THRESHOLD	OPERATING OVP THRESHOLD	OVP DELAY 100 mV OD (μ s)	OVP RESET
Internal	Internal	$1.2 \times \text{Internal } V_{REF}$	$1.2 \times \text{Internal } V_{REF}$	1	UVP

7.3.7.4 Out-of-Bounds Operation

The device has an out-of-bounds (OOB) overvoltage protection that protects the output load at a much lower overvoltage threshold of 8% above the target voltage. OOB protection does not trigger an overvoltage fault, so the device is not latched off after an OOB event. OOB protection operates as an early no-fault overvoltage-protection mechanism. During the OOB operation, the controller operates in forced PWM mode only by turning on the low-side FET. Turning on the low-side FET beyond the zero inductor current quickly discharges the output capacitor thus causing the output voltage to fall quickly toward the setpoint. During the operation, the cycle-by-cycle negative current limit is also activated to ensure the safe operation of the internal FETs.

7.3.7.5 Overtemperature Protection

TPS548D22 device has overtemperature protection (OTP) by monitoring the die temperature. If the temperature exceeds the threshold value (default value 165°C), TPS548D22 device is shut off. When the temperature falls about 25°C below the threshold value, the device turns on again. The OTP is a non-latch protection.

7.4 Device Functional Modes

7.4.1 DCAP3 Control Topology

The TPS548D22 employs an artificial ramp generator that stabilizes the loop. The ramp amplitude is automatically adjusted as a function of selected switching frequency (f_{SW}). The ramp amplitude is a function of duty cycle (V_{OUT} -to- V_{IN} ratio). Consequently, two additional pin-strap bits (FSEL[2:1]) are provided for fine tuning the internal ramp amplitude. The device uses an improved DCAP3 control loop architecture that incorporates a steady-state error integrator. The slow integrator improves the output voltage DC accuracy greatly and presents minimal impact to small signal transient response. To further enhance the small signal stability of the control loop, the device uses a modified ramp generator that supports a wider range of output LC stage.

7.4.2 DCAP Control Topology

For advanced users of this device, the internal DCAP3 ramp can be disabled using the MODE[4] pin strap bit. This situation requires an external RCC network to ensure control loop stability. Place this RCC network across the output inductor. Use a range between 10 mV and 15 mV of injected RSP pin ripple. If no feedback resistor divider network is used, insert a 10-k Ω resistor between the VOUT pin and the RSP pin.

7.5 Programming

7.5.1 Programmable Pin-Strap Settings

FSEL, VSEL, and MODE. Description: a 1% or better 100-k Ω resistor is needed from BP to each of the three pins. The bottom resistor from each pin to ground (see [Table 2](#)) in conjunction with the top resistor defines each pin strap selection. The pin detection checks for external resistor divider ratio during initial power up (V_{DD} is brought down below approximately 3 V) when BP LDO output is at approximately 2.9 V.

7.5.1.1 Frequency Selection (FSEL) Pin

The TPS548D22 device allows users to select the switching frequency, light load and internal ramp amplitude by using FSEL pin. [Table 2](#) lists the divider resistor values for the selection. The 1% tolerance resistors with typical temperature coefficient of ± 100 ppm/ $^{\circ}$ C are recommended. Higher performance resistors can be used if tighter noise margin is required for more reliable frequency selection detection.

FSEL pin strap configuration programs the switching frequency, internal ramp compensation and light load conduction mode.

Programming (continued)
Table 2. FSEL Pin Strap Configurations

FSEL[4]	FSEL[3]	FSEL[2]	FSEL[1]	FSEL[0]	R _{FSEL} (kΩ) ⁽¹⁾
FSEL[1:0]		RCSP_FSEL[1:0]		CM	
11: 1.05 MHz		11: R × 3		1: FCCM	Open
				0: SKIP	187
		10: R × 2		1: FCCM	165
				0: SKIP	147
		01: R × 1		1: FCCM	133
				0: SKIP	121
00: R/2		1: FCCM	110		
		0: SKIP	100		
10: 875 kHz		11: R × 3		1: FCCM	90.9
				0: SKIP	82.5
		10: R × 2		1: FCCM	75
				0: SKIP	68.1
		01: R × 1		1: FCCM	60.4
				0: SKIP	53.6
00: R/2		1: FCCM	47.5		
		0: SKIP	42.2		
01: 650 kHz		11: R × 3		1: FCCM	37.4
				0: SKIP	33.2
		10: R × 2		1: FCCM	29.4
				0: SKIP	25.5
		01: R × 1		1: FCCM	22.1
				0: SKIP	19.1
00: R/2		1: FCCM	16.5		
		0: SKIP	14.3		
00: 425 kHz		11: R × 3		1: FCCM	12.1
				0: SKIP	10
		10: R × 2		1: FCCM	7.87
				0: SKIP	6.19
		01: R × 1		1: FCCM	4.64
				0: SKIP	3.16
00: R/2		1: FCCM	1.78		
		0: SKIP	0		

(1) 1% or better and connect to ground

7.5.1.2 VSEL Pin

VSEL pin strap configuration is used to program initial boot voltage value, hiccup mode, and latch-off mode. The initial boot voltage is used to program the main loop voltage reference point. VSEL voltage settings provide TI designated discrete internal reference voltages. [Table 3](#) lists internal reference voltage selections.

Table 3. Internal Reference Voltage Selections

VSEL[4]	VSEL[3]	VSEL[2]	VSEL[1]	VSEL[0]	R _{VSEL} (kΩ) ⁽¹⁾
1111: 0.975 V				1: Latch-Off	Open
				0: Hiccup	187
1110: 1.1992 V				1: Latch-Off	165
				0: Hiccup	147
1101: 1.1504 V				1: Latch-Off	133
				0: Hiccup	121
1100: 1.0996 V				1: Latch-Off	110
				0: Hiccup	100
1011: 1.0508 V				1: Latch-Off	90.9
				0: Hiccup	82.5
1010: 1.0000 V				1: Latch-Off	75
				0: Hiccup	68.1
1001: 0.9492 V				1: Latch-Off	60.4
				0: Hiccup	53.6
1000: 0.9023 V				1: Latch-Off	47.5
				0: Hiccup	42.2
0111: 0.9004 V				1: Latch-Off	37.4
				0: Hiccup	33.2
0110: 0.8496 V				1: Latch-Off	29.4
				0: Hiccup	25.5
0101: 0.8008 V				1: Latch-Off	22.1
				0: Hiccup	19.1
0100: 0.7500 V				1: Latch-Off	16.5
				0: Hiccup	14.3
0011: 0.6992 V				1: Latch-Off	12.1
				0: Hiccup	10
0010: 0.6504 V				1: Latch-Off	7.87
				0: Hiccup	6.19
0001: 0.5996 V				1: Latch-Off	4.64
				0: Hiccup	3.16
0000: 0.975 V				1: Latch-Off	1.78
				0: Hiccup	0

(1) 1% or better and connect to ground

7.5.1.3 DCAP3 Control and Mode Selection

The MODE pinstrap configuration programs the control topology and internal soft-start timing selections. The TPS548D22 device supports both DCAP3 and DCAP operation

MODE[4] selection bit is used to set the control topology. If MODE[4] bit is 0, it selects DCAP operation. If MODE[4] bit is 1, it selects DCAP3 operation.

MODE[1] and MODE[0] selection bits are used to set the internal soft-start timing.

Table 4. Allowable MODE Pin Selections

MODE[4]	MODE[3]	MODE[2]	MODE[1]	MODE[0]	R _{MODE} (kΩ) ⁽¹⁾
1: DCAP3	0: Internal Reference	0: Internal SS	11: 8 ms ⁽²⁾		60.4
			10: 4 ms ⁽²⁾		53.6
			01: 2 ms		47.5
			00: 1 ms		42.2
0: DCAP	0: Internal Reference	0: Internal SS	11: 8 ms ⁽²⁾		4.64
			10: 4 ms ⁽²⁾		3.16
			01: 2 ms		1.78
			00: 1 ms		0

(1) 1% or better and connect to ground

(2) See [Application Workaround to Support 4-ms and 8-ms SS Settings](#).

7.5.1.3.1 Application Workaround to Support 4-ms and 8-ms SS Settings

In order to properly design for 4-ms and 8-ms SS settings, additional application consideration is needed. The recommended application workaround to support the 4-ms and 8-ms soft-start settings is to ensure sufficient time delay between the VDD and EN_UVLO signals. The minimum delay between the rising maximum VDD_UVLO level and the minimum turnon threshold of EN_UVLO is at least T_{DELAY_MIN}.

$$T_{DELAY_MIN} = K \times V_{REF}$$

where

- K = 9 ms/V for SS setting of 4 ms
- K = 18 ms/V for SS setting of 8 ms
- V_{REF} is the internal reference voltage programmed by VSEL pin strap (1)

For example, if SS setting is 4 ms and V_{REF} = 1 V, program the minimum delay at least 9 ms; if SS setting is 8 ms, the minimum delay should be programmed at least 18 ms. See [Figure 16](#) and [Figure 17](#) for detailed timing requirement.

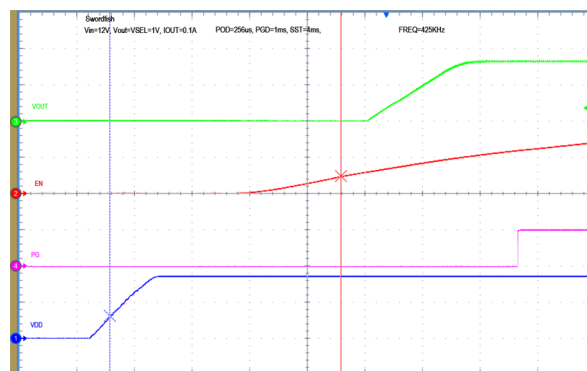

Figure 16. Proper Sequencing of V_{DD} and EN_UVLO to Support the use of 4-ms SS Setting

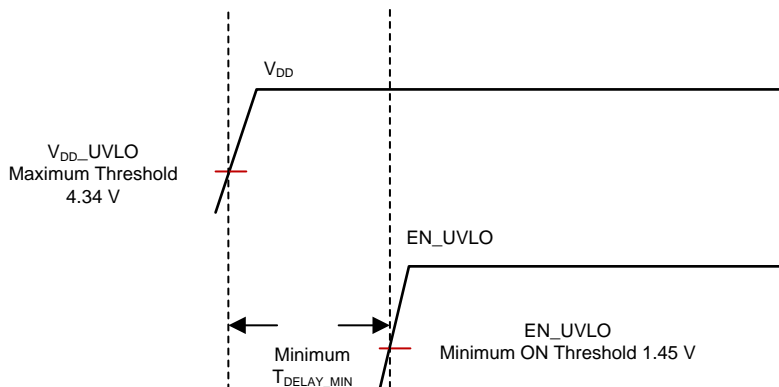

Figure 17. Minimum Delay Between V_{DD} and EN_UVLO to Support the use of 4-ms and 8-ms SS settings

The workaround/consideration described previously is not required for SS settings of 1 ms and 2 ms.

7.5.2 Programmable Analog Configurations

7.5.2.1 RSP/RSN Remote Sensing Functionality

RSP and RSN pins are used for remote sensing purpose. In the case where feedback resistors are required for output voltage programming, the RSP pin must be connected to the mid-point of the resistor divider, and the RSN pin must always be connected to the load return. In the case where feedback resistors are not required, such as when the VSEL programs the output voltage setpoint, the RSP pin must be connected to the positive sensing point of the load, and the RSN pin should always be connected to the load return.

RSP and RSN pins are extremely high-impedance input terminals of the true differential remote sense amplifier. The feedback resistor divider should use resistor values much less than 100 k Ω .

7.5.2.1.1 Output Differential Remote Sensing Amplifier

The examples in this section show simplified remote sensing circuitry where each example uses an internal reference of 1 V. Figure 18 shows remote sensing without feedback resistors, with an output voltage set point of 1 V. Figure 19 shows remote sensing using feedback resistors, with an output voltage set point of 5 V.

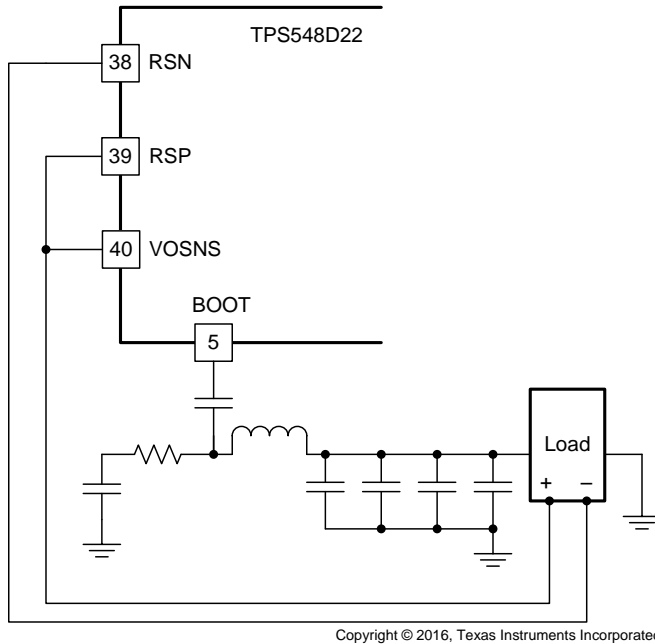

Figure 18. Remote Sensing Without Feedback Resistors

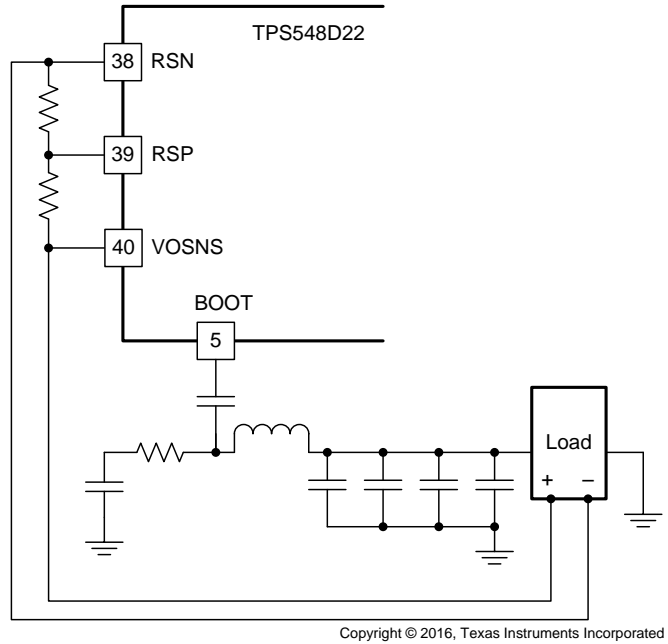

Figure 19. Remote Sensing With Feedback Resistors

7.5.2.2 Power Good (PGOOD Pin) Functionality

The TPS548D22 device has power-good output that registers high when switcher output is within the target. The power-good function is activated after soft-start has finished. When the soft-start ramp reaches 300 mV above the internal reference voltage, SSend signal goes high to enable the PGOOD detection function. If the output voltage becomes within $\pm 8\%$ of the target value, internal comparators detect power-good state and the power good signal becomes high after an 8-ms programmable delay. If the output voltage goes outside of $\pm 16\%$ of the target value, the power good signal becomes low after two microsecond (2- μ s) internal delay. The open-drain power-good output must be pulled up externally. The internal N-channel MOSFET does not pull down until the VDD supply is above 1.2 V.

8 Application and Implementation

NOTE

Information in the following applications sections is not part of the TI component specification, and TI does not warrant its accuracy or completeness. TI's customers are responsible for determining suitability of components for their purposes. Customers should validate and test their design implementation to confirm system functionality.

8.1 Application Information

The TPS548D22 device is a highly-integrated synchronous step-down DC-DC converters. These devices are used to convert a higher DC input voltage to a lower DC output voltage, with a maximum output current of 40 A. Use the following design procedure to select key component values for this family of devices.

TPS548D22

ZHCSEX9D – MARCH 2016 – REVISED JULY 2017

www.ti.com.cn

8.2 Typical Applications

8.2.1 TPS548D22 1.5-V to 16-V Input, 1-V Output, 40-A Converter

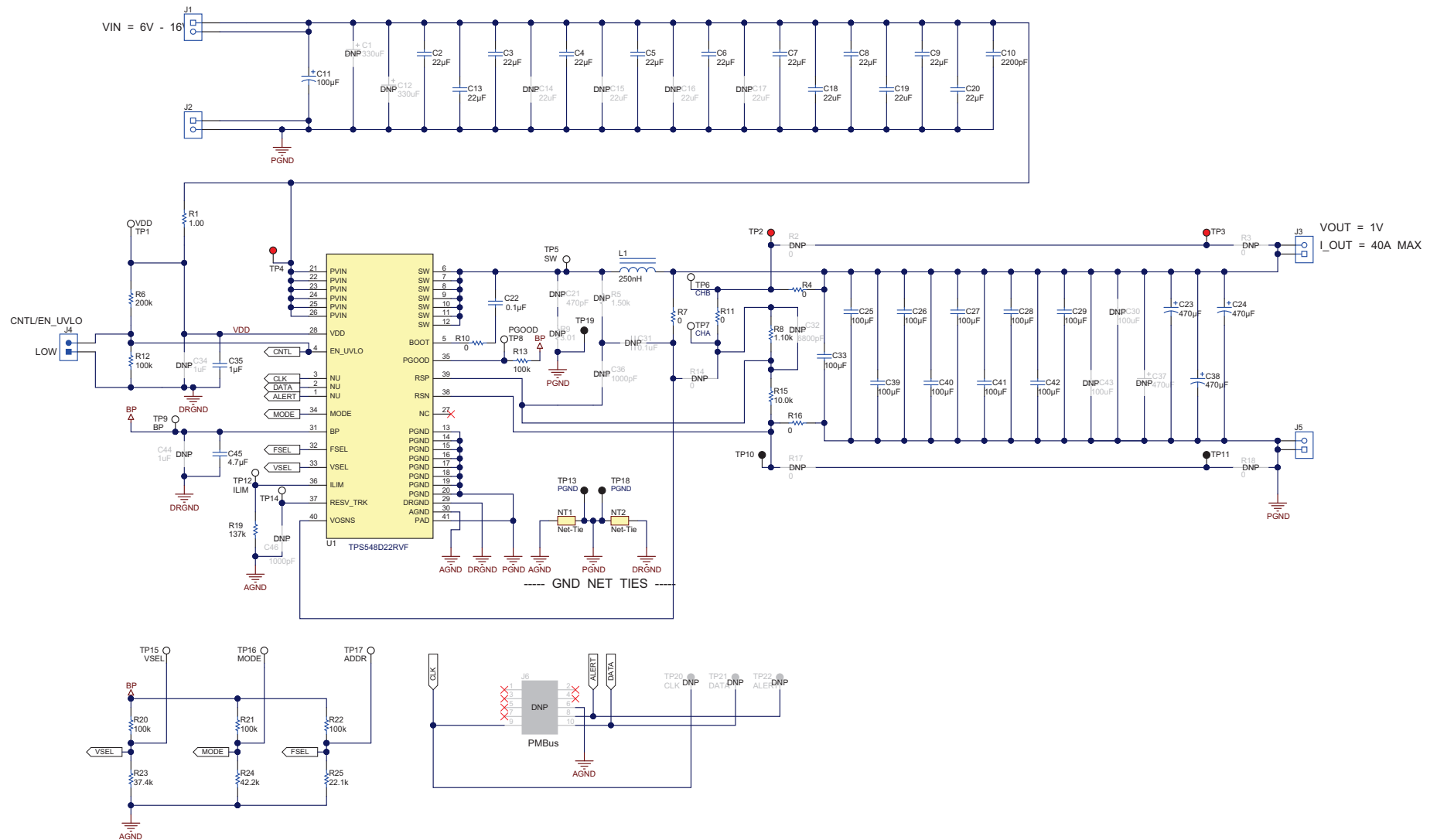

Copyright © 2017, Texas Instruments Incorporated

Figure 20. Typical Application Schematic

8.2.2 Design Requirements

For this design example, use the input parameters shown in [Table 5](#).

Table 5. Design Example Specifications

PARAMETER		TEST CONDITION	MIN	TYP	MAX	UNIT
V_{IN}	Input voltage		5	12	16	V
$V_{IN(ripple)}$	Input ripple voltage	$I_{OUT} = 40\text{ A}$			0.4	V
V_{OUT}	Output voltage			1		V
	Line regulation	$5\text{ V} \leq V_{IN} \leq 16\text{ V}$			0.5%	
	Load regulation	$0\text{ V} \leq I_{OUT} \leq 40\text{ A}$			0.5%	
V_{PP}	Output ripple voltage	$I_{OUT} = 40\text{ A}$		20		mV
V_{OVER}	Transient response overshoot	$I_{STEP} = 24\text{ A}$		90		mV
V_{UNDER}	Transient response undershoot	$I_{STEP} = 24\text{ A}$		90		mV
I_{OUT}	Output current	$5\text{ V} \leq V_{IN} \leq 16\text{ V}$			40	A
t_{SS}	Soft-start time	$V_{IN} = 12\text{ V}$		1		ms
I_{OC}	Overcurrent trip point ⁽¹⁾			46		A
η	Peak Efficiency	$I_{OUT} = 20\text{ A}$, $V_{IN} = 12\text{ V}$, $V_{DD} = 5\text{ V}$		90%		
f_{SW}	Switching frequency			650		kHz

(1) DC overcurrent level

8.2.3 Design Procedure

8.2.3.1 Switching Frequency Selection

Select a switching frequency for the regulator. There is a trade off between higher and lower switching frequencies. Higher switching frequencies may produce smaller a solution size using lower valued inductors and smaller output capacitors compared to a power supply that switches at a lower frequency. However, the higher switching frequency causes extra switching losses, which decrease efficiency and impact thermal performance. In this design, a moderate switching frequency of 650 kHz achieves both a small solution size and a high-efficiency operation with the frequency selected.

Select one of four switching frequencies and FSEL resistor values from [Table 6](#). The recommended high-side R_{FSEL} value is 100 k Ω (1%). Choose a low-side resistor value from [Table 6](#) based on the choice of switching frequency. For each switching frequency selection, there are multiple values of $R_{FSEL(LS)}$ to choose from. In order to select the correct value, additional considerations (internal ramp compensation and light load operation) other than switching frequency need to be included.

Table 6. FSEL Pin Selection

SWITCHING FREQUENCY f_{sw} (kHz)	FSEL VOLTAGE V_{FSEL} (V)		HIGH-SIDE RESISTOR $R_{FSEL(HS)}$ (k Ω) 1% or better	LOW-SIDE RESISTOR $R_{FSEL(LS)}$ (k Ω) 1% or better
	MAXIMUM	MINIMUM		
1050	2.93	1.465	100	Open
				187
				165
				147
				133
				121
				110
				100

Table 6. FSEL Pin Selection (continued)

875	1.396	0.869	100	90.9
				82.5
				75
				68.1
				60.4
				53.6
				47.5
				42.2
650	0.798	0.366	100	37.4
				33.2
				29.4
				25.5
				22.1
				19.1
				16.5
				14.3
425	0.317	0	100	12.1
				10
				7.87
				6.19
				4.64
				3.16
				1.78
				0

There is some limited freedom to choose FSEL resistors that have other than the recommended values. The criteria is to ensure that for particular selection of switching frequency, the FSEL voltage is within the maximum and minimum FSEL voltage levels listed in [Table 6](#). Use [Equation 2](#) to calculate the FSEL voltage. Select FSEL resistors that include tolerances of 1% or better.

$$V_{\text{FSEL}} = V_{\text{BP}(\text{det})} \times \frac{R_{\text{FSEL}(\text{LS})}}{R_{\text{FSEL}(\text{HS})} + R_{\text{FSEL}(\text{LS})}}$$

where

- $V_{\text{BP}(\text{det})}$ is the voltage used by the device to program the level of valid FSEL pin voltage during initial device start-up (2.9 V typ) (2)

In addition to serving the frequency select purpose, the FSEL pin can also be used to program internal ramp compensation (DCAP3) and light-load conduction mode. When DCAP3 mode is selected (see section 8.2.3.9), internal ramp compensation is used for stabilizing the converter design. The internal ramp compensation is a function of the switching frequency (f_{SW}) and the duty cycle range (the output voltage-to-input voltage ratio). [Table 7](#) summarizes the ramp choices using these functions.

Table 7. Switching Frequency Selection

SWITCHING FREQUENCY SETTING (f _{sw}) (kHz)	RAMP SELECT OPTION	TIME CONSTANT t (μs)	V _{OUT} RANGE (FIXED V _{IN} = 12 V)		DUTY CYCLE RANGE (V _{OUT} /V _{IN}) (%)	
			MIN	MAX	MIN	MAX
425	R/2	9	0.6	0.9	5	7.5
	R × 1	16.8	0.9	1.5	7.5	12.5
	R × 2	32.3	1.5	2.5	12.5	21
	R × 3	55.6	2.5	5.5	>21	
650	R/2	7	0.6	0.9	5	7.5
	R × 1	13.5	0.9	1.5	7.5	12.5
	R × 2	25.9	1.5	2.5	12.5	21
	R × 3	44.5	2.5	5.5	>21	
875	R/2	5.6	0.6	0.9	5	7.5
	R × 1	10.4	0.9	1.5	7.5	12.5
	R × 2	20	1.5	2.5	12.5	21
	R × 3	34.4	2.5	5.5	>21	
1050	R/2	3.8	0.6	0.9	5	7.5
	R × 1	7.1	0.9	1.5	7.5	12.5
	R × 2	13.6	1.5	2.5	12.5	21
	R × 3	23.3	2.5	5.5	>21	

The FSEL pin programs the light-load selection. TPS548D22 device supports either SKIP mode or FCCM operations. For optimized light-load efficiency, it is recommended to program the device to operate in SKIP mode. For better load regulation from no load to full load, it is recommended to program the device to operate in FCCM mode.

R_{FSEL(LS)} can be determined after determining the switching frequency, ramp and light-load operation. [Table 2](#) lists the full range of choices.

8.2.3.2 Inductor Selection

To calculate the value of the output inductor, use [Equation 3](#). The coefficient K_{IND} represents the amount of inductor ripple current relative to the maximum output current. The output capacitor filters the inductor ripple current. Therefore, choosing a high inductor ripple current impacts the selection of the output capacitor since the output capacitor must have a ripple current rating equal to or greater than the inductor ripple current. In general, maintain a K_{IND} coefficient between 0 and 15 for balanced performance. Using this target ripple current, the required inductor size can be calculated as shown in [Equation 3](#)

$$L_1 = \frac{V_{OUT}}{(V_{IN(max)} \times f_{SW})} \times \frac{V_{IN} - V_{OUT}}{(I_{OUT(max)} \times K_{IND})} = \frac{1 \text{ V} \times (16 \text{ V} - 1 \text{ V})}{(16 \text{ V} \times 650 \text{ kHz} \times 40 \text{ A} \times 0.15)} = 0.24 \text{ } \mu\text{H} \quad (3)$$

Selecting a K_{IND} of 0.15, the target inductance L₁ = 250 nH. Using the next standard value, the 250 nH is chosen in this application for its high current rating, low DCR, and small size. The inductor ripple current, RMS current, and peak current can be calculated using [Equation 4](#), [Equation 5](#) and [Equation 6](#). These values should be used to select an inductor with approximately the target inductance value, and current ratings that allow normal operation with some margin.

$$I_{RIPPLE} = \frac{V_{OUT}}{(V_{IN(max)} \times f_{SW})} \times \frac{V_{IN(max)} - V_{OUT}}{L_1} = \frac{1 \text{ V} \times (16 \text{ V} - 1 \text{ V})}{16 \text{ V} \times 650 \text{ kHz} \times 250 \text{ nH}} = 5.64 \text{ A} \quad (4)$$

$$I_{L(rms)} = \sqrt{(I_{OUT})^2 + \frac{1}{12} \times (I_{RIPPLE})^2} = 40 \text{ A} \quad (5)$$

$$I_{L(peak)} = (I_{OUT}) + \frac{1}{2} \times (I_{RIPPLE}) = 43 \text{ A} \quad (6)$$

The Würth ferrite 744309025 inductor is rated for 50 A_{RMS} current, and 48-A saturation. Using this inductor, the ripple current I_{RIPPLE} = 5.64 A, the RMS inductor current I_{L(rms)} = 40 A, and peak inductor current I_{L(peak)} = 43 A.

8.2.3.3 Output Capacitor Selection

There are three primary considerations for selecting the value of the output capacitor. The output capacitor affects three criteria:

- Stability
- Regulator response to a change in load current or load transient
- Output voltage ripple

These three considerations are important when designing regulators that must operate where the electrical conditions are unpredictable. The output capacitance needs to be selected based on the most stringent of these three criteria.

8.2.3.3.1 Minimum Output Capacitance to Ensure Stability

To prevent sub-harmonic multiple pulsing behavior, TPS548D22 application designs must strictly follow the small signal stability considerations described in [Equation 7](#).

$$C_{OUT(min)} > \frac{t_{ON}}{2} \times \frac{8\tau}{L_{OUT}} \times \frac{V_{REF}}{V_{OUT}}$$

where

- C_{OUT(min)} is the minimum output capacitance needed to meet the stability requirement of the design
- t_{ON} is the on-time information based on the switching frequency and duty cycle (in this design, 133 ns)
- τ is the ramp compensation time constant of the design based on the switching frequency and duty cycle, (in this design, 13.45 μs, refer to [Table 7](#))
- L_{OUT} is the output inductance (in the design, 0.25 μH)
- V_{REF} is the user-selected reference voltage level (in this design, 1 V)
- V_{OUT} is the output voltage (in this design, 1 V)

(7)

The minimum output capacitance calculated from [Equation 7](#) is 28.6 μF. The stability is ensured when the amount of the output capacitance is 28.6 μF or greater. And when all MLCCs (multi-layer ceramic capacitors) are used, both DC and AC derating effects must be considered to ensure that the minimum output capacitance requirement is met with sufficient margin.

8.2.3.3.2 Response to a Load Transient

The output capacitance must supply the load with the required current when current is not immediately provided by the regulator. When the output capacitor supplies load current, the impedance of the capacitor greatly affects the magnitude of voltage deviation (such as undershoot and overshoot) during the transient.

Use [Equation 8](#) and [Equation 9](#) to estimate the amount of capacitance needed for a given dynamic load step and release.

NOTE

There are other factors that can impact the amount of output capacitance for a specific design, such as ripple and stability.

$$C_{OUT(min_under)} = \frac{L_{OUT} \times (\Delta I_{LOAD(max)})^2 \times \left(\frac{V_{OUT} \times t_{SW}}{V_{IN(min)}} + t_{OFF(min)} \right)}{2 \times \Delta V_{LOAD(insert)} \times \left(\left(\frac{V_{IN(min)} - V_{OUT}}{V_{IN(min)}} \right) \times t_{SW} - t_{OFF(min)} \right) \times V_{OUT}}$$

(8)

$$C_{OUT(\text{min_over})} = \frac{L_{OUT} \times (\Delta I_{LOAD(\text{max})})^2}{2 \times \Delta V_{LOAD(\text{release})} \times V_{OUT}}$$

where

- $C_{OUT(\text{min_under})}$ is the minimum output capacitance to meet the undershoot requirement
- $C_{OUT(\text{min_over})}$ is the minimum output capacitance to meet the overshoot requirement
- L is the output inductance value (0.25 μH)
- $\Delta I_{LOAD(\text{max})}$ is the maximum transient step (24 A)
- V_{OUT} is the output voltage value (1 V)
- t_{SW} is the switching period (1.538 μs)
- $V_{IN(\text{min})}$ is the minimum input voltage for the design (10.8 V)
- $t_{OFF(\text{min})}$ is the minimum off time of the device (300 ns)
- $\Delta V_{LOAD(\text{insert})}$ is the undershoot requirement (30 mV)
- $\Delta V_{LOAD(\text{release})}$ is the overshoot requirement (30 mV)

(9)

Most of the above parameters can be found in [Table 5](#).

The minimum output capacitance to meet the undershoot requirement is 969 μF . The minimum output capacitance to meet the overshoot requirement is 2400 μF . This example uses a combination of POSCAP and MLCC capacitors to meet the overshoot requirement.

- POSCAP bank #1: 4 x 470 μF , 2.5 V, 6 m Ω per capacitor
- MLCC bank #2: 10 x 100 μF , 2.5 V, 1 m Ω per capacitor with DC+AC derating factor of 60%

Recalculating the worst case overshoot using the described capacitor bank design, the overshoot is 29.0 mV which meets the 30 mV overshoot specification requirement.

8.2.3.3.3 Output Voltage Ripple

The output voltage ripple is another important design consideration. [Equation 10](#) calculates the minimum output capacitance required to meet the output voltage ripple specification. This criterion is the requirement when the impedance of the output capacitance is dominated by ESR.

$$C_{OUT(\text{min})\text{RIPPLE}} = \frac{I_{\text{RIPPLE}}}{8 \times f_{\text{SW}} \times V_{OUT(\text{ripple})}} = 108 \mu\text{F}$$

(10)

In this case, the maximum output voltage ripple is 10 mV. For this requirement, the minimum capacitance for ripple requirement yields 108 μF . Because this capacitance value is significantly lower compared to that of transient requirement, determine the capacitance bank from step 8.2.3.3.2. Because the output capacitor bank consists of both POSCAP and MLCC type capacitors, it is important to consider the ripple effect at the switching frequency due to effective ESR. Use [Equation 11](#) to determine the maximum ESR of the output capacitor bank for the switching frequency.

$$ESR_{\text{MAX}} = \frac{V_{OUT(\text{ripple})} - \frac{I_{\text{RIPPLE}}}{8 \times f_{\text{SW}} \times C_{OUT}}}{I_{\text{RIPPLE}}} = 1.7 \text{ m}\Omega$$

(11)

Estimate the effective ESR at the switching frequency by obtaining the impedance vs. frequency characteristics of the output capacitors. The parallel impedance of capacitor bank #1 and capacitor bank #2 at the switching frequency of the design example is estimated to be 1.2 m Ω , which is less than that of the maximum ESR value. Therefore, the output voltage ripple requirement (7 mV) can be met. For detailed calculation on the effective ESR please contact the factory to obtain a user-friendly Excel based design tool.

8.2.3.4 Input Capacitor Selection

The TPS548D22 devices require a high-quality, ceramic, type X5R or X7R, input decoupling capacitor with a value of at least 1 μF of effective capacitance on the VDD pin, relative to AGND. The power stage input decoupling capacitance (effective capacitance at the PVIN and PGND pins) must be sufficient to supply the high switching currents demanded when the high-side MOSFET switches on, while providing minimal input voltage ripple as a result. This effective capacitance includes any DC bias effects. The voltage rating of the input capacitor must be greater than the maximum input voltage. The capacitor must also have a ripple current rating greater than the maximum input current ripple to the device during full load. The input ripple current can be calculated using Equation 12.

$$I_{\text{CIN (rms)}} = I_{\text{OUT (max)}} \times \sqrt{\frac{V_{\text{OUT}}}{V_{\text{IN (min)}}} \times \frac{(V_{\text{IN (min)}} - V_{\text{OUT}})}{V_{\text{IN (min)}}}} = 16 \text{ Arms} \quad (12)$$

The minimum input capacitance and ESR values for a given input voltage ripple specification, $V_{\text{IN(ripple)}}$, are shown in Equation 13 and Equation 14. The input ripple is composed of a capacitive portion, $V_{\text{RIPPLE(cap)}}$, and a resistive portion, $V_{\text{RIPPLE(esr)}}$.

$$C_{\text{IN (min)}} = \frac{I_{\text{OUT (max)}} \times V_{\text{OUT}}}{V_{\text{RIPPLE (cap)}} \times V_{\text{IN (max)}} \times f_{\text{SW}}} = 38.5 \mu\text{F} \quad (13)$$

$$\text{ESR}_{\text{CIN (max)}} = \frac{V_{\text{RIPPLE(ESR)}}}{I_{\text{OUT (max)}} + \left(\frac{I_{\text{RIPPLE}}}{2}\right)} = 7 \text{ m}\Omega \quad (14)$$

The value of a ceramic capacitor varies significantly over temperature and the amount of DC bias applied to the capacitor. The capacitance variations due to temperature can be minimized by selecting a dielectric material that is stable over temperature. X5R and X7R ceramic dielectrics are usually selected for power regulator capacitors because they have a high capacitance to volume ratio and are fairly stable over temperature. The input capacitor must also be selected with the DC bias taken into account. For this example design, a ceramic capacitor with at least a 25-V voltage rating is required to support the maximum input voltage. For this design, allow 0.1-V input ripple for $V_{\text{RIPPLE(cap)}}$, and 0.3-V input ripple for $V_{\text{RIPPLE(esr)}}$. Using Equation 13 and Equation 14, the minimum input capacitance for this design is 38.5 μF , and the maximum ESR is 9.4 $\text{m}\Omega$. For this example, four 22- μF , 25-V ceramic capacitors and one additional 100- μF , 25-V low-ESR polymer capacitors in parallel were selected for the power stage.

8.2.3.5 Bootstrap Capacitor Selection

A ceramic capacitor with a value of 0.1 μF must be connected between the BOOT and SW pins for proper operation. It is recommended to use a ceramic capacitor with X5R or better grade dielectric. Use a capacitor with a voltage rating of 25 V or higher.

8.2.3.6 BP Pin

Bypass the BP pin to DRGND with 4.7- μF of capacitance. In order for the regulator to function properly, it is important that these capacitors be localized to the TPS548D22, with low-impedance return paths. See [Layout Guidelines](#) section for more information.

8.2.3.7 R-C Snubber and VIN Pin High-Frequency Bypass

Though it is possible to operate the TPS548D22 within absolute maximum ratings without ringing reduction techniques, some designs may require external components to further reduce ringing levels. This example uses two approaches: a high frequency power stage bypass capacitor on the VIN pins, and an R-C snubber between the SW area and GND.

The high-frequency VIN bypass capacitor is a lossless ringing reduction technique which helps minimize the outboard parasitic inductances in the power stage, which store energy during the low-side MOSFET on-time, and discharge once the high-side MOSFET is turned on. For this example twin 2.2-nF, 25-V, 0603-sized high-frequency capacitors are used. The placement of these capacitors is critical to its effectiveness. Its ideal placement is shown in [Figure 20](#).

Additionally, an R-C snubber circuit is added to this example. To balance efficiency and spike levels, a 1-nF capacitor and a 1-Ω resistor are chosen. In this example a 0805-sized resistor is chosen, which is rated for 0.125 W, nearly twice the estimated power dissipation. See [SLUP100](#) for more information about snubber circuits.

8.2.3.8 Optimize Reference Voltage (VSEL)

Optimize the reference voltage by choosing a value for R_{VSEL} . The TPS548D22 device is designed with a wide range of precision reference voltage support from 0.6 V to 1.2 V with an available step change of 50 mV. Program these reference voltages using the VSEL pin strap configurations. See [Table 3](#) for internal reference voltage selections. In addition to providing initial boot voltage value, use the VSEL pin to program hiccup and latch-off mode.

There are two ways to program the output voltage set point. If the output voltage set point is one of the 16 available reference and boot voltage options, no feedback resistors are required for output voltage programming. In the case where feedback resistors are not needed, connect the RSP pin to the positive sensing point of the load. Always connect the RSN pin to the load return sensing point.

In this design example, since the output voltage set point is 1 V, selecting $R_{VSEL(LS)}$ of either 75 kΩ (latch off) or 68.1 kΩ (hiccup) as shown in [Table 3](#). If the output voltage set point is NOT one of the 16 available reference or boot voltage options, feedback resistors are required for output voltage programming. Connect the RSP pin to the mid-point of the resistor divider. Always connect the RSN pin to the load return sensing point as shown in [Figure 18](#) and [Figure 19](#).

The general guideline to select boot and internal reference voltage is to select the reference voltage closest to the output voltage set point. In addition, because the RSP and RSN pins are extremely high-impedance input terminals of the true differential remote sense amplifier, use a feedback resistor divider with values much less than 100 kΩ.

8.2.3.9 MODE Pin Selection

MODE pin strap configuration is used to program control topology and internal soft-start timing selections. TPS548D22 supports both DCAP3 and DCAP operation. For general POL applications, it is strongly recommended to configure the control topology to be DCAP3 due to its simple to use and no external compensation features. In the rare instance where DCAP is needed, an RCC network across the output inductor is needed to generate sufficient ripple voltage on the RSP pin. In this design example, $R_{MODE(LS)}$ of 42.2 kΩ is selected for DCAP3 and soft start time of 1 ms.

8.2.3.10 Overcurrent Limit Design.

The TPS548D22 device uses the ILIM pin to set the OCP level. Connect the ILIM pin to GND through the voltage setting resistor, R_{ILIM} . In order to provide both good accuracy and cost effective solution, this device supports temperature compensated MOSFET on-resistance ($R_{DS(on)}$) sensing. Also, this device performs both positive and negative inductor current limiting with the same magnitudes. Positive current limit is normally used to protect the inductor from saturation therefore causing damage to the high-side and low-side FETs. Negative current limit is used to protect the low-side FET during OVP discharge.

The inductor current is monitored by the voltage between PGND pin and SW pin during the OFF time. The ILIM pin has 3000 ppm/°C temperature slope to compensate the temperature dependency of the on-resistance. The PGND pin is used as the positive current sensing node.

TPS548D22 has cycle-by-cycle over-current limiting control. The inductor current is monitored during the OFF state and the controller maintains the OFF state during the period that the inductor current is larger than the overcurrent ILIM level. The voltage on the ILIM pin (V_{ILIM}) sets the valley level of the inductor current. The range of value of the R_{ILIM} resistor is between 21 kΩ and 237 kΩ. The range of valley OCL is between 6.25 A and 75 A (typical). If the R_{ILIM} resistance is outside of the recommended range, OCL accuracy and function cannot be guaranteed. (see [Table 8](#)).

Table 8. Closed Loop EVM Measurement of OCP Settings

R _{ILIM} (kΩ)	OVERCURRENT PROTECTION VALLEY (A)		
	MIN	NOM	MAX
237	—	75	—
127	36	40	44
95.3	27	30	33
63.4	18	20	22
32.4	9	10	11
21	—	6.25	—

Use [Equation 15](#) to relate the valley OCL to the R_{ILIM} resistance.

$$OCL_{VALLEY} = 0.3178 \times R_{ILIM} - 0.3046$$

where

- R_{ILIM} is in kΩ
- OCL_{VALLEY} is in A (15)

In this design example, the desired valley OCL is 43 A, the calculated R_{ILIM} is 137 kΩ. Use [Equation 16](#) to calculate the DC OCL to be 46 A.

$$OCL_{DC} = OCL_{VALLEY} + 0.5 \times I_{RIPPLE}$$

where

- R_{ILIM} is in kΩ
- OCL_{DC} is in A (16)

In an overcurrent condition, the current to the load exceeds the inductor current and the output voltage falls. When the output voltage crosses the under-voltage fault threshold for at least 1msec, the behavior of the device depends on the VSEL pin strap setting. If hiccup mode is selected, the device will restart after 16-ms delay (1-ms soft-start option). If the overcurrent condition persists, the OC hiccup behavior repeats. During latch-off mode operation the device shuts down until the EN pin is toggled or VDD pin is power cycled.

8.2.4 Application Curves

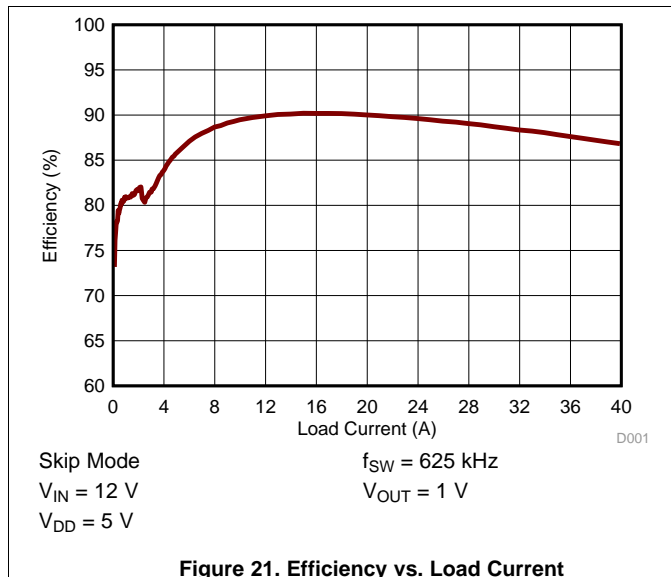

Figure 21. Efficiency vs. Load Current

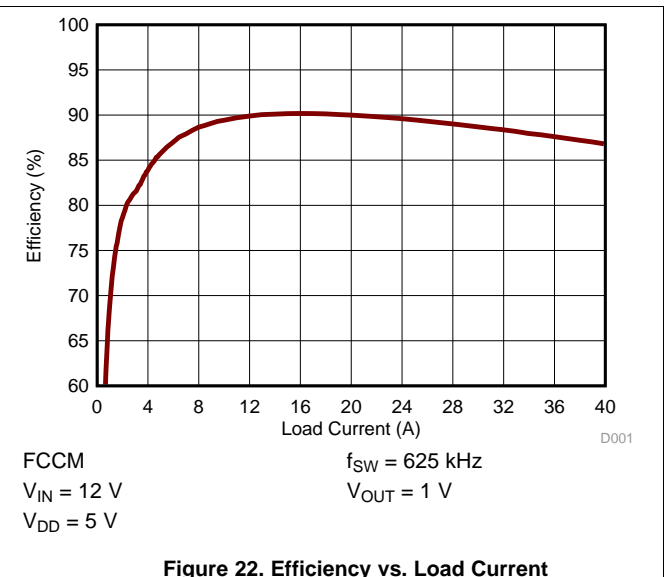

Figure 22. Efficiency vs. Load Current

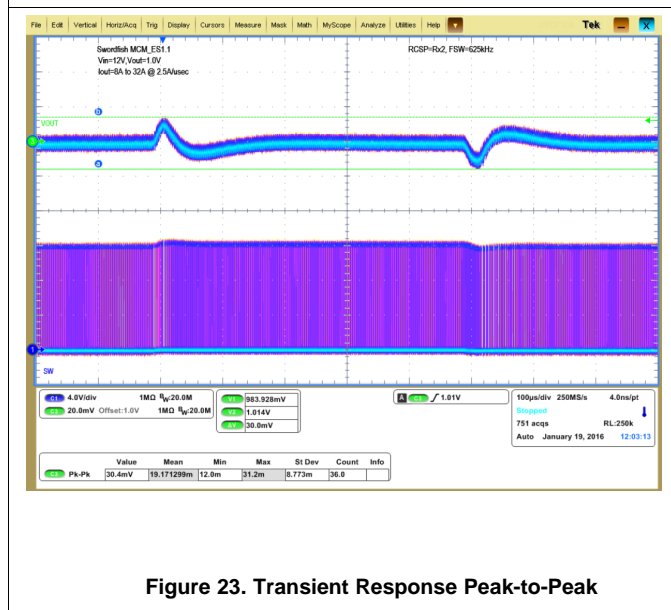

Figure 23. Transient Response Peak-to-Peak

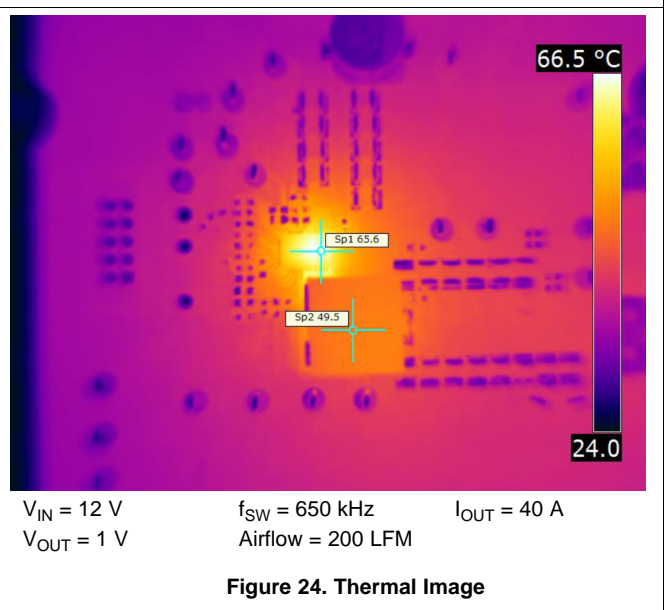

Figure 24. Thermal Image

9 Power Supply Recommendations

This device is designed to operate from an input voltage supply between 1.5 V and 16 V. Ensure the supply is well regulated. Proper bypassing of input supplies and internal regulators is also critical for noise performance, as is the quality of the PCB layout and grounding scheme. See the recommendations in the [Layout](#) section.

10 Layout

10.1 Layout Guidelines

Consider these layout guidelines before starting a layout work using TPS548D22.

- It is absolutely critical that all GND pins, including AGND (pin 30), DRGND (pin 29), and PGND (pins 13, 14, 15, 16, 17, 18, 19, and 20) are connected directly to the thermal pad underneath the device via traces or plane.
- Include as many thermal vias as possible to support a 40-A thermal operation. For example, a total of 35 thermal vias are used (outer diameter of 20 mil) in the TPS548D22EVM-784 available for purchase at ti.com. ([SLUUBE4](#))
- Place the power components (including input/output capacitors, output inductor and TPS548D22 device) on one side of the PCB (solder side). Insert at least two inner layers (or planes) connected to the power ground, in order to shield and isolate the small signal traces from noisy power lines.
- Place the VIN pin decoupling capacitors as close as possible to the PVIN and PGND pins to minimize the input AC current loop. Place a high-frequency decoupling capacitor (with a value between 1 nF and 0.1 μ F) as close to the PVIN pin and PGND pin as the spacing rule allows. This placement helps suppress the switch node ringing.
- Place VDD and BP decoupling capacitors as close to the device pins as possible. Do not use PVIN plane connection for the VDD pin. Separate the VDD signal from the PVIN signal by using separate trace connections. Provide GND vias for each decoupling capacitor and make the loop as small as possible.
- Ensure that the PCB trace defined as switch node (which connects the SW pins and up-stream of the output inductor) are as short and wide as possible. In the TPS548D22EVM-784 EVM design, the SW trace width is 200 mil. Use a separate via or trace to connect SW node to snubber and bootstrap capacitor. Do not combine these connections.
- Place all sensitive analog traces and components (including VOSNS, RSP, RSN, ILIM, MODE, VSEL and FSEL) far away from any high voltage switch node (itself and others), such as SW and BOOT to avoid noise coupling. In addition, place MODE, VSEL and FSEL programming resistors near the device pins.
- The RSP and RSN pins operate as inputs to a differential remote sense amplifier that operates with very high impedance. It is essential to route the RSP and RSN pins as a pair of diff-traces in Kelvin-sense fashion. Route them directly to either the load sense points (+ and –) or the output bulk capacitors. The internal circuit uses the VOSNS pin for on-time adjustment. It is critical to tie the VOSNS pin directly tied to VOUT (load sense point) for accurate output voltage result.

10.2 Layout Example



图 25. EVM Top View



图 26. EVM Top Layer

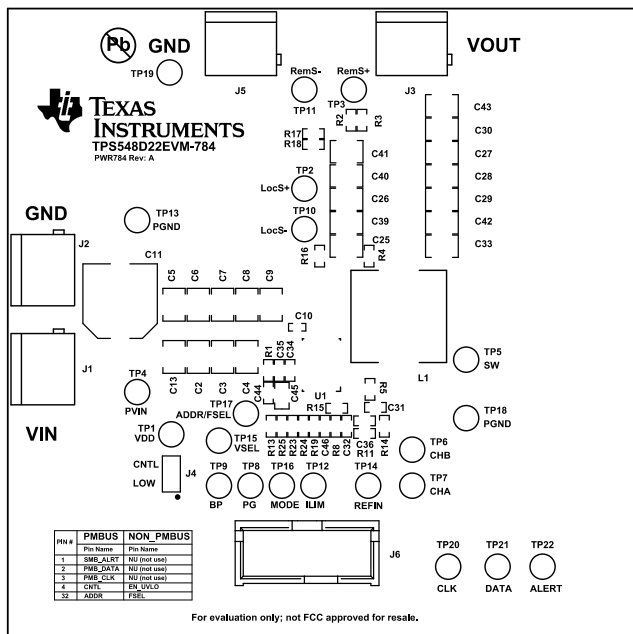

图 27. EVM Inner Layer 1

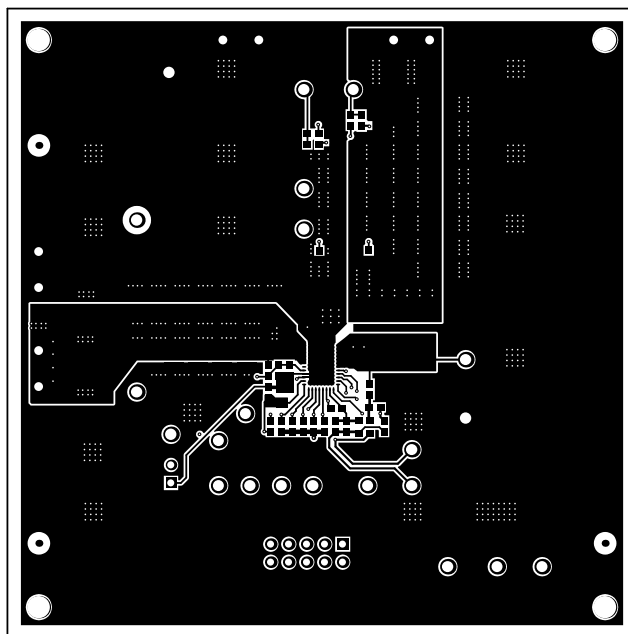

图 28. EVM Inner Layer 2

Layout Example (接下页)

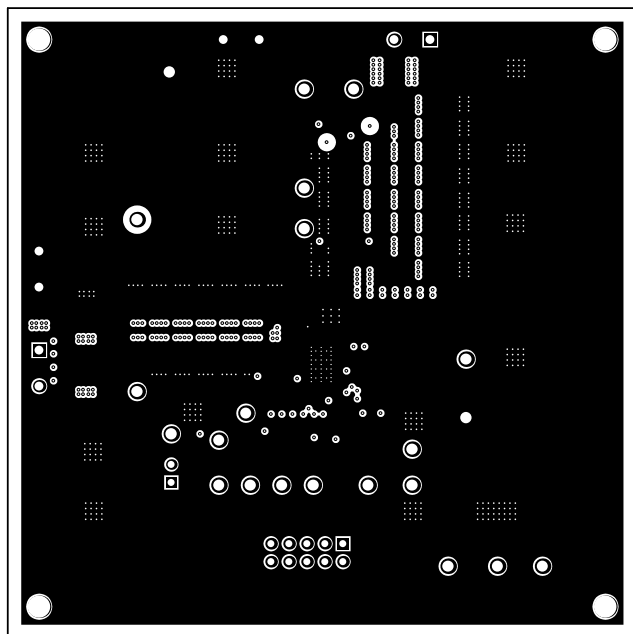

图 29. EVM Inner Layer 3

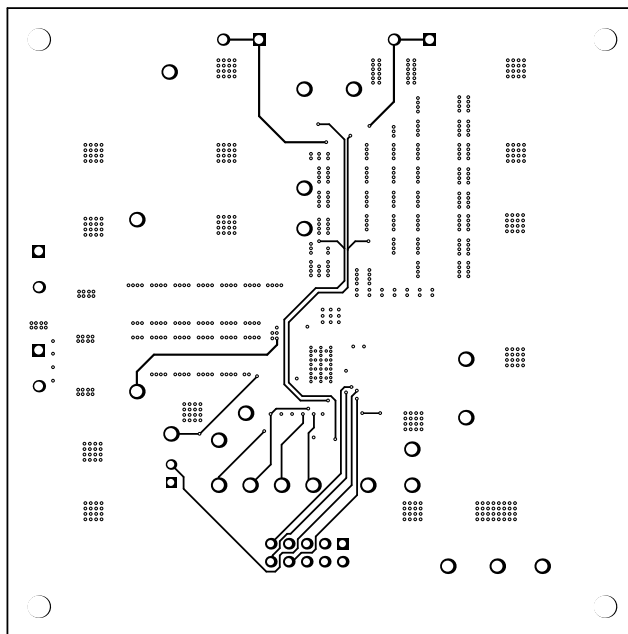

图 30. EVM Inner Layer 4

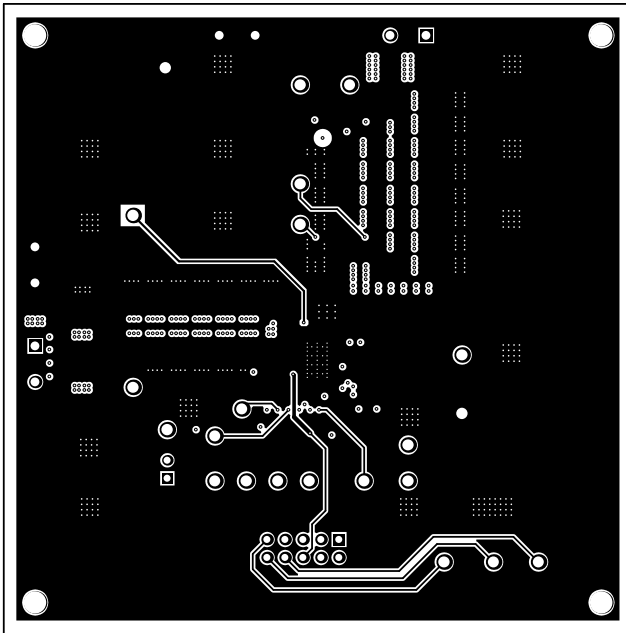

图 31. EVM Bottom Layer

Layout Example (接下页)

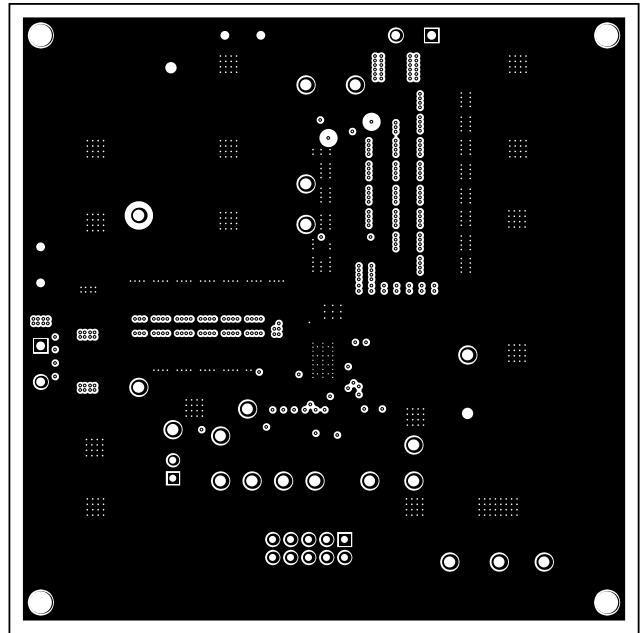
10.2.1 Mounting and Thermal Profile Recommendation

Proper mounting technique adequately covers the exposed thermal tab with solder. Excessive heat during the reflow process can affect electrical performance. 图 32 shows the recommended reflow oven thermal profile. Proper post-assembly cleaning is also critical to device performance. See the Application Report, *QFN/SON PCB Attachment*, (SLUA271) for more information.

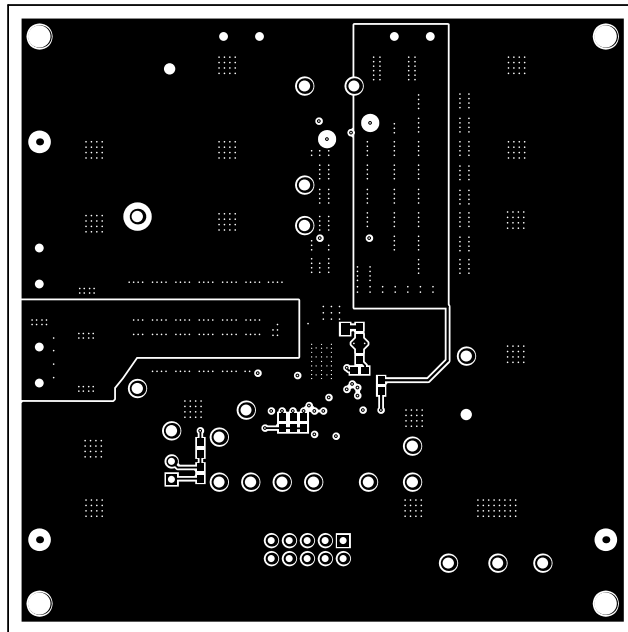

图 32. Recommended Reflow Oven Thermal Profile

表 9. Recommended Thermal Profile Parameters

PARAMETER		MIN	TYP	MAX	UNIT
RAMP UP AND RAMP DOWN					
$r_{\text{RAMP(up)}}$	Average ramp-up rate, $T_{\text{S(max)}}$ to T_{P}			3	°C/s
$r_{\text{RAMP(down)}}$	Average ramp-down rate, T_{P} to $T_{\text{S(max)}}$			6	°C/s
PRE-HEAT					
T_{S}	Pre-heat temperature	150		200	°C
t_{S}	Pre-heat time, $T_{\text{S(min)}}$ to $T_{\text{S(max)}}$	60		180	s
REFLOW					
T_{L}	Liquidus temperature		217		°C
T_{P}	Peak temperature			260	°C
t_{L}	Time maintained above liquidus temperature, T_{L}	60		150	s
t_{P}	Time maintained within 5°C of peak temperature, T_{P}	20		40	s
$t_{25\text{P}}$	Total time from 25°C to peak temperature, T_{P}			480	s

11 器件和文档支持

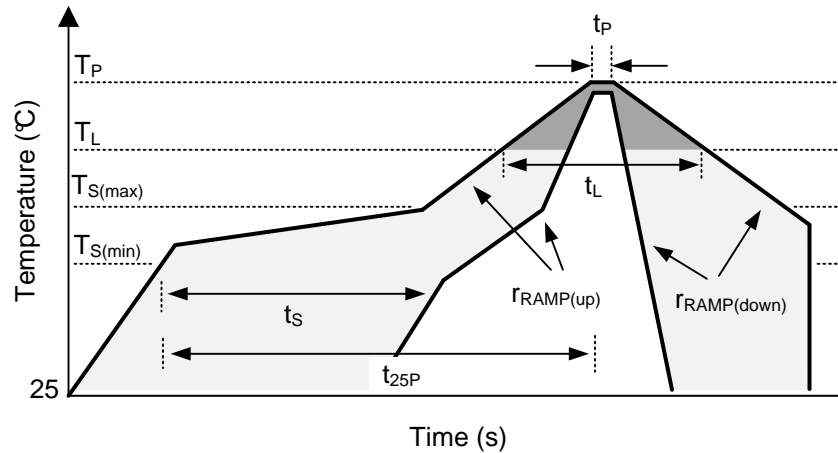
11.1 器件支持

11.1.1 Third-Party Products Disclaimer

TI'S PUBLICATION OF INFORMATION REGARDING THIRD-PARTY PRODUCTS OR SERVICES DOES NOT CONSTITUTE AN ENDORSEMENT REGARDING THE SUITABILITY OF SUCH PRODUCTS OR SERVICES OR A WARRANTY, REPRESENTATION OR ENDORSEMENT OF SUCH PRODUCTS OR SERVICES, EITHER ALONE OR IN COMBINATION WITH ANY TI PRODUCT OR SERVICE.

11.2 接收文档更新通知

要接收文档更新通知，请导航至 TI.com 上的器件产品文件夹。请单击右上角的通知我进行注册，即可收到所有的产品更改信息每周摘要。有关更改的详细信息，请查看任何已修订文档中包含的修订历史记录。

11.3 社区资源

下列链接提供到 TI 社区资源的连接。链接的内容由各个分销商“按照原样”提供。这些内容并不构成 TI 技术规范，并且不一定反映 TI 的观点；请参阅 TI 的《使用条款》。

TI E2E™ 在线社区 *TI 的工程师对工程师 (E2E) 社区*。此社区的创建目的在于促进工程师之间的协作。在 e2e.ti.com 中，您可以咨询问题、分享知识、拓展思路并与同行工程师一道帮助解决问题。

设计支持 *TI 参考设计支持* 可帮助您快速查找有帮助的 E2E 论坛、设计支持工具以及技术支持的联系信息。

11.4 商标

D-CAP3, Eco-mode, NexFET, E2E are trademarks of Texas Instruments.
All other trademarks are the property of their respective owners.

11.5 静电放电警告



这些装置包含有限的内置 ESD 保护。存储或装卸时，应将导线一起截短或将装置放置于导电泡棉中，以防止 MOS 门极遭受静电损伤。

11.6 Glossary

SLYZ022 — *TI Glossary*.

This glossary lists and explains terms, acronyms, and definitions.

12 机械、封装和可订购信息

以下页面包含机械、封装和可订购信息。这些信息是指定器件的最新可用数据。这些数据如有变更，恕不另行通知和修订此文档。如欲获取此数据表的浏览器版本，请参阅左侧的导航。

12.1 Package Option Addendum

12.1.1 Packaging Information

Orderable Device	Status ⁽¹⁾	Package Type	Package Drawing	Pins	Package Qty	Eco Plan ⁽²⁾	Lead/Ball Finish ⁽³⁾	MSL Peak Temp ⁽⁴⁾	Op Temp (°C)	Device Marking ⁽⁵⁾⁽⁶⁾
TPS548D22RVFR	ACTIVE	LQFN-CLIP	RVF	40	2500	Pb-Free (RoHS Exempt)	CU NIPDAU	Level-2-260C-1 YEAR	–40 to 125	TPS548D22
TPS548D22RVFT	ACTIVE	LQFN-CLIP	RVF	40	250	Pb-Free (RoHS Exempt)	CU NIPDAU	Level-2-260C-1 YEAR	–40 to 125	TPS548D22

- (1) The marketing status values are defined as follows:
ACTIVE: Product device recommended for new designs.
LIFEBUY: TI has announced that the device will be discontinued, and a lifetime-buy period is in effect.
NRND: Not recommended for new designs. Device is in production to support existing customers, but TI does not recommend using this part in a new design.
PRE_PROD Unannounced device, not in production, not available for mass market, nor on the web, samples not available.
PREVIEW: Device has been announced but is not in production. Samples may or may not be available.
OBSOLETE: TI has discontinued the production of the device.
- (2) Eco Plan - The planned eco-friendly classification: Pb-Free (RoHS), Pb-Free (RoHS Exempt), or Green (RoHS & no Sb/Br) - please check <http://www.ti.com/productcontent> for the latest availability information and additional product content details.
TBD: The Pb-Free/Green conversion plan has not been defined.
Pb-Free (RoHS): TI's terms "Lead-Free" or "Pb-Free" mean semiconductor products that are compatible with the current RoHS requirements for all 6 substances, including the requirement that lead not exceed 0.1% by weight in homogeneous materials. Where designed to be soldered at high temperatures, TI Pb-Free products are suitable for use in specified lead-free processes.
Pb-Free (RoHS Exempt): This component has a RoHS exemption for either 1) lead-based flip-chip solder bumps used between the die and package, or 2) lead-based die adhesive used between the die and leadframe. The component is otherwise considered Pb-Free (RoHS compatible) as defined above.
Green (RoHS & no Sb/Br): TI defines "Green" to mean Pb-Free (RoHS compatible), and free of Bromine (Br) and Antimony (Sb) based flame retardants (Br or Sb do not exceed 0.1% by weight in homogeneous material)
- (3) Lead/Ball Finish - Orderable Devices may have multiple material finish options. Finish options are separated by a vertical ruled line. Lead/Ball Finish values may wrap to two lines if the finish value exceeds the maximum column width.
- (4) MSL, Peak Temp. -- The Moisture Sensitivity Level rating according to the JEDEC industry standard classifications, and peak solder temperature.
- (5) There may be additional marking, which relates to the logo, the lot trace code information, or the environmental category on the device
- (6) Multiple Device markings will be inside parentheses. Only on Device Marking contained in parentheses and separated by a "-" will appear on a device. If a line is indented then it is a continuation of the previous line and the two combined represent the entire Device Marking for that device.

Important Information and Disclaimer: The information provided on this page represents TI's knowledge and belief as of the date that it is provided. TI bases its knowledge and belief on information provided by third parties, and makes no representation or warranty as to the accuracy of such information. Efforts are underway to better integrate information from third parties. TI has taken and continues to take reasonable steps to provide representative and accurate information but may not have conducted destructive testing or chemical analysis on incoming materials and chemicals. TI and TI suppliers consider certain information to be proprietary, and thus CAS numbers and other limited information may not be available for release.

In no event shall TI's liability arising out of such information exceed the total purchase price of the TI part(s) at issue in this document sold by TI to Customer on an annual basis.

TPS548D22

ZHCSEX9D – MARCH 2016 – REVISED JULY 2017

www.ti.com.cn

12.1.2 Tape and Reel Information

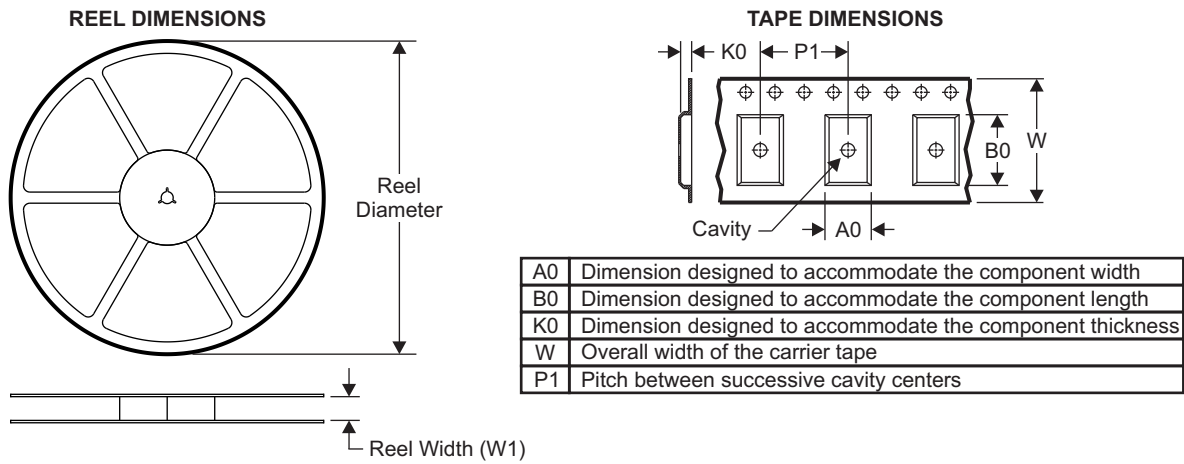

QUADRANT ASSIGNMENTS FOR PIN 1 ORIENTATION IN TAPE

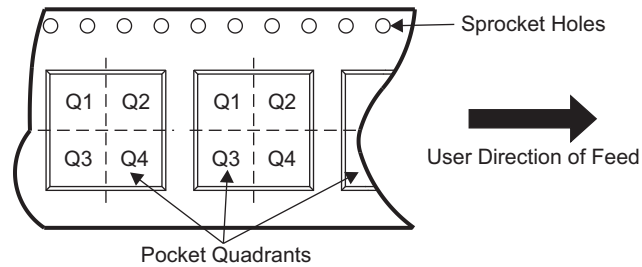

Device	Package Type	Package Drawing	Pins	SPQ	Reel Diameter (mm)	Reel Width W1 (mm)	A0 (mm)	B0 (mm)	K0 (mm)	P1 (mm)	W (mm)	Pin1 Quadrant
TPS548D22RVFR	LQFN-CLIP	RVF	40	2500	330.0	16.4	5.35	7.35	1.7	8.0	16.0	Q3
TPS548D22RVFT	LQFN-CLIP	RVF	40	250	178.0	16.4	5.35	7.35	1.7	8.0	16.0	Q3

TAPE AND REEL BOX DIMENSIONS

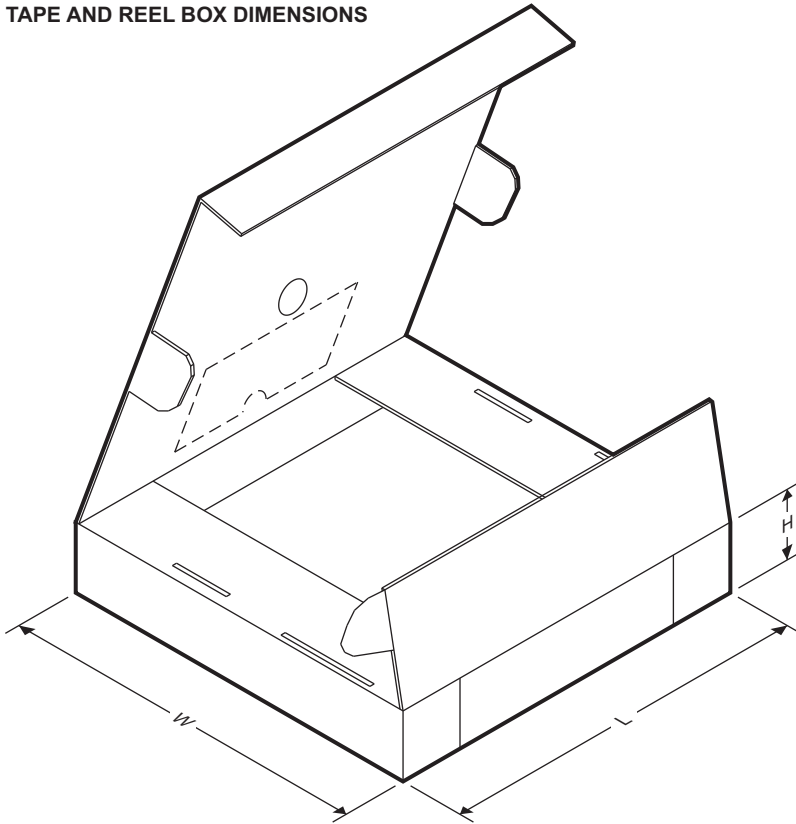

Device	Package Type	Package Drawing	Pins	SPQ	Length (mm)	Width (mm)	Height (mm)
TPS548D22RVFR	LQFN-CLIP	RVF	40	2500	367.0	367.0	38.0
TPS548D22RVFT	LQFN-CLIP	RVF	40	250	210.0	185.0	35.0

TAPE AND REEL INFORMATION



QUADRANT ASSIGNMENTS FOR PIN 1 ORIENTATION IN TAPE



*All dimensions are nominal

Device	Package Type	Package Drawing	Pins	SPQ	Reel Diameter (mm)	Reel Width W1 (mm)	A0 (mm)	B0 (mm)	K0 (mm)	P1 (mm)	W (mm)	Pin1 Quadrant
TPS548D22RVFR	LQFN-CLIP	RVF	40	2500	330.0	16.4	5.35	7.35	1.7	8.0	16.0	Q1
TPS548D22RVFT	LQFN-CLIP	RVF	40	250	180.0	16.4	5.35	7.35	1.7	8.0	16.0	Q1

TAPE AND REEL BOX DIMENSIONS

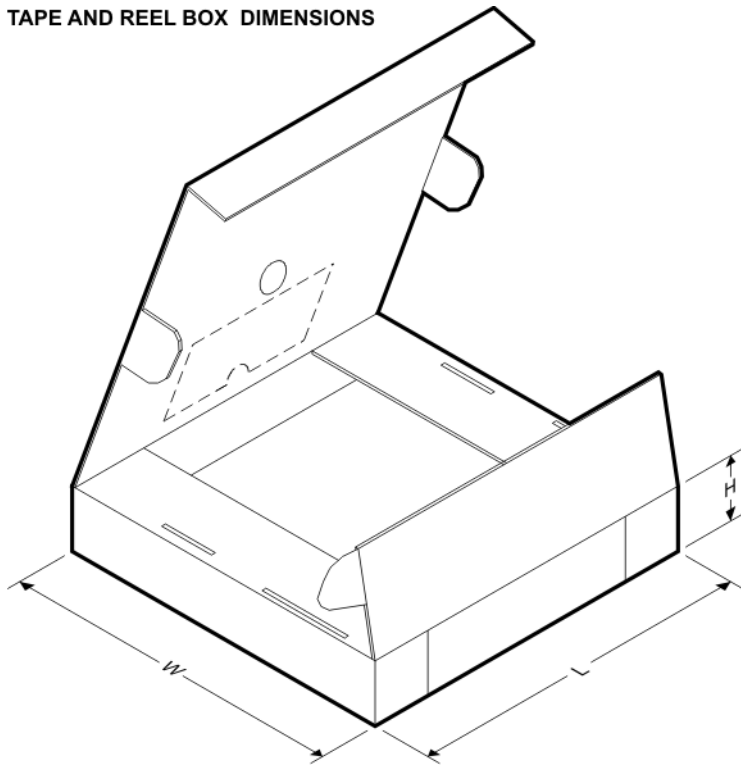

*All dimensions are nominal

Device	Package Type	Package Drawing	Pins	SPQ	Length (mm)	Width (mm)	Height (mm)
TPS548D22RVFR	LQFN-CLIP	RVF	40	2500	367.0	367.0	38.0
TPS548D22RVFT	LQFN-CLIP	RVF	40	250	210.0	185.0	35.0

GENERIC PACKAGE VIEW

RVF 40

LQFN-CLIP - 1.52 mm max height

PLASTIC QUAD FLATPACK - NO LEAD

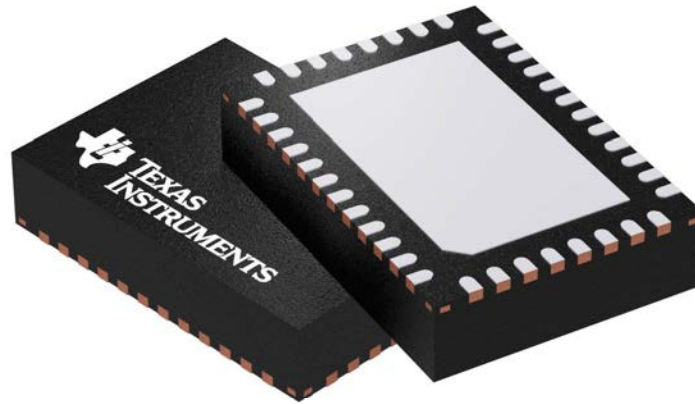

Images above are just a representation of the package family, actual package may vary.
Refer to the product data sheet for package details.

4211383/D

EXAMPLE BOARD LAYOUT

RVF0040A

LQFN-CLIP - 1.52 mm max height

PLASTIC QUAD FLATPACK - NO LEAD

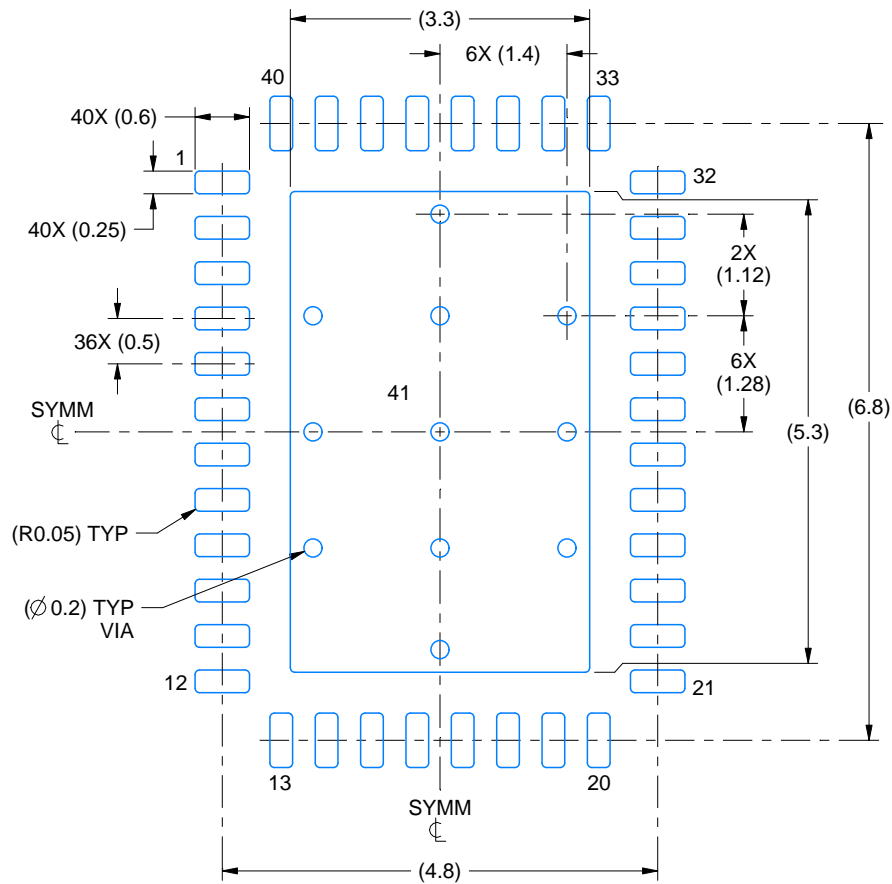

LAND PATTERN EXAMPLE
SCALE:12X

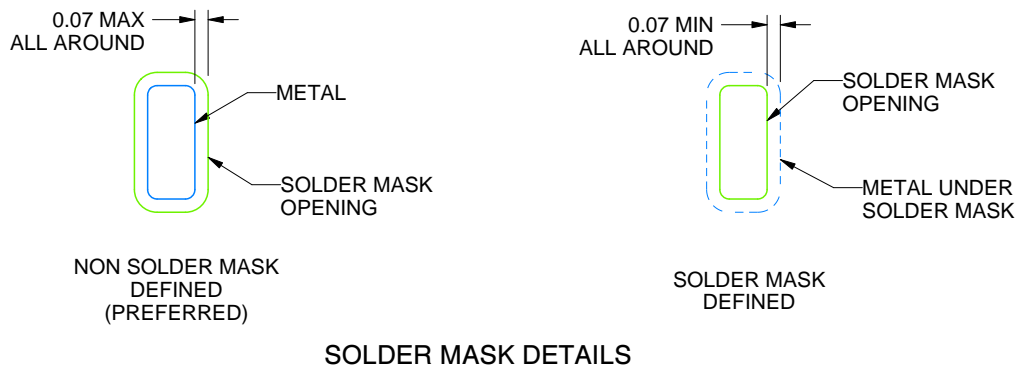

SOLDER MASK DETAILS

4222989/B 10/2017

NOTES: (continued)

5. This package is designed to be soldered to a thermal pad on the board. For more information, see Texas Instruments literature number SLUA271 (www.ti.com/lit/slua271).

EXAMPLE STENCIL DESIGN

RVF0040A

LQFN-CLIP - 1.52 mm max height

PLASTIC QUAD FLATPACK - NO LEAD

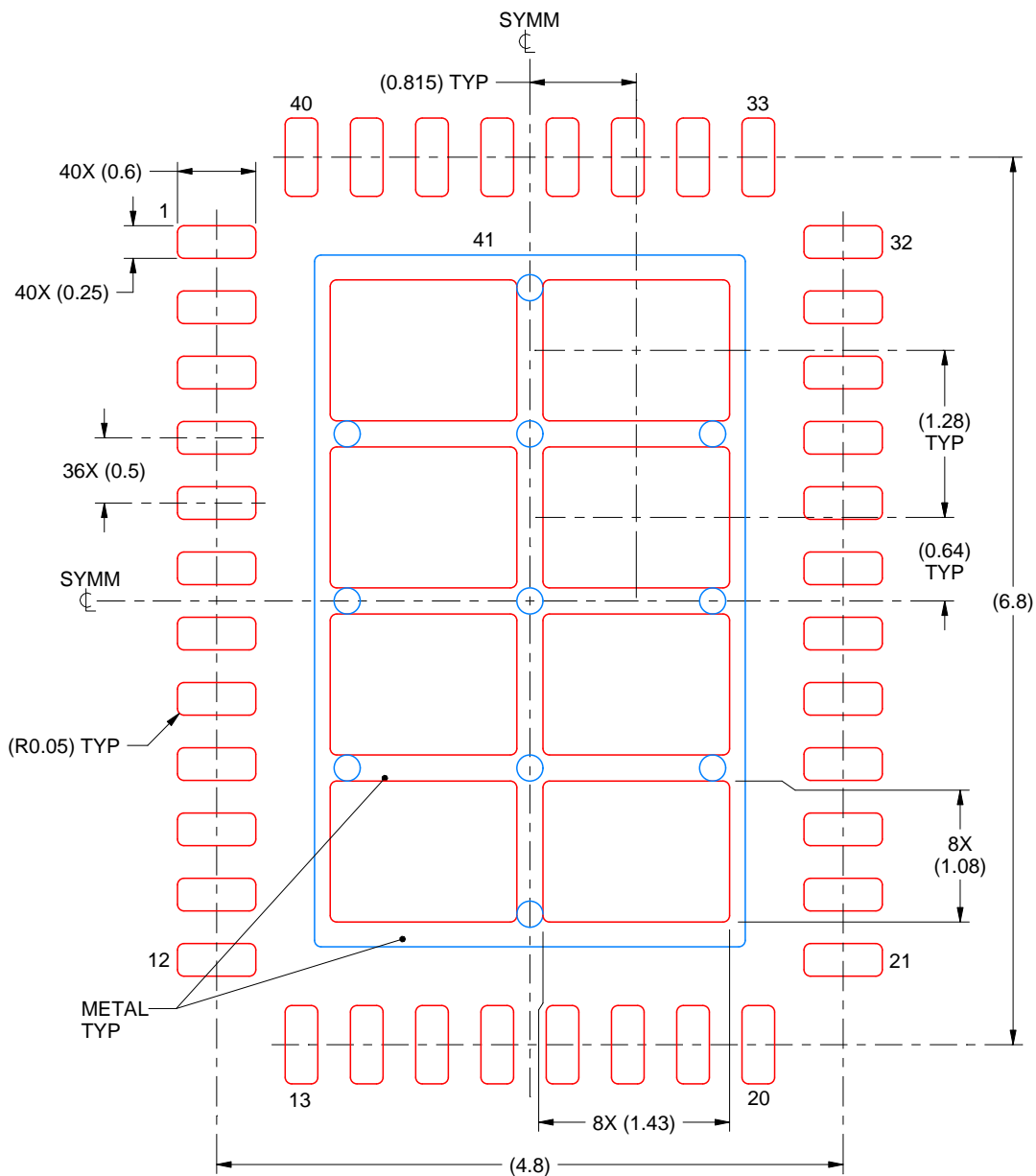

SOLDER PASTE EXAMPLE
BASED ON 0.125 mm THICK STENCIL

EXPOSED PAD
71% PRINTED SOLDER COVERAGE BY AREA
SCALE:18X

4222989/B 10/2017

NOTES: (continued)

6. Laser cutting apertures with trapezoidal walls and rounded corners may offer better paste release. IPC-7525 may have alternate design recommendations.

重要声明和免责声明

TI 均以“原样”提供技术性数据（包括数据表）、设计资源（包括参考设计）、应用或其他设计建议、网络工具、安全信息和其他资源，不保证其中不含任何瑕疵，且不做任何明示或暗示的担保，包括但不限于对适销性、适合某特定用途或不侵犯任何第三方知识产权的暗示担保。

所述资源可供专业开发人员应用TI 产品进行设计使用。您将对以下行为独自承担全部责任：(1) 针对您的应用选择合适的TI 产品；(2) 设计、验证并测试您的应用；(3) 确保您的应用满足相应标准以及任何其他安全、安保或其他要求。所述资源如有变更，恕不另行通知。TI 对您使用所述资源的授权仅限于开发资源所涉及TI 产品的相关应用。除此之外不得复制或展示所述资源，也不提供其它TI 或任何第三方的知识产权授权许可。如因使用所述资源而产生任何索赔、赔偿、成本、损失及债务等，TI 对此概不负责，并且您须赔偿由此对TI 及其代表造成的损害。

TI 所提供产品均受TI 的销售条款 (<http://www.ti.com.cn/zh-cn/legal/termsofsale.html>) 以及ti.com.cn上或随附TI产品提供的其他可适用条款的约束。TI提供所述资源并不扩展或以其他方式更改TI 针对TI 产品所发布的可适用的担保范围或担保免责声明。

邮寄地址：上海市浦东新区世纪大道 1568 号中建大厦 32 楼，邮政编码：200122
Copyright © 2019 德州仪器半导体技术（上海）有限公司