

## TPS6240x 2.25-MHz 400-mA and 600-mA Dual Step-Down Converter In Small 3-mm x 3-mm VSON Package

### 1 Features

- High Efficiency—Up to 95%
- $V_{IN}$  Range From 2.5 V to 6 V
- 2.25-MHz Fixed Frequency Operation
- Output Current of 400 mA and 600 mA
- Adjustable Output Voltage From 0.6V to  $V_{IN}$
- Pin-Selectable Output Voltage Supports Simple Dynamic Voltage Scaling
- EasyScale™ Optional One-Pin Serial Interface
- Power Save Mode at Light Load Currents
- 180° Out-of-Phase Operation
- Output Voltage Accuracy in PWM Mode  $\pm 1\%$
- Typical 32- $\mu$ A Quiescent Current for Both Converters
- 100% Duty Cycle for Lowest Dropout
- Available in a 10-Pin VSON (3 mm x 3 mm)

### 2 Applications

- Cell Phones, Smart Phones
- PDAs, Pocket PCs
- OMAP™ and Low-Power DSP Supply
- Portable Media Players
- Digital Radios
- Digital Cameras

### 3 Description

The TPS6240x family of devices are synchronous dual step-down DC-DC converters optimized for battery-powered portable applications. The devices provide two independent output voltage rails powered by 1-cell Li-Ion or 3-cell NiMH/NiCD batteries. The devices are also suitable to operate from a standard 3.3-V or 5-V voltage rail.

With an input voltage range from 2.5 V to 6 V, the TPS6240x is ideal to power portable applications like smart phones, PDAs, and other portable equipment.

With the EasyScale serial interface the output voltages can be modified during operation. The fixed output voltage versions TPS62401, TPS62402, TPS62403, and TPS62404 support one-pin controlled simple Dynamic Voltage Scaling for low-power processors.

The TPS6240x operates at a 2.25-MHz fixed switching frequency and enters the power save mode operation at light load currents to maintain high efficiency over the entire load current range. For low noise applications the devices can be forced into fixed frequency PWM mode by pulling the MODE/DATA pin high. In the shutdown mode, the current consumption is reduced to 1.2  $\mu$ A, typical. The devices allow the use of small inductors and capacitors to achieve a small solution size.

The TPS6240x is available in a 10-pin leadless package (3-mm x 3-mm VSON)

#### Device Information<sup>(1)</sup>

PART NUMBER	PACKAGE	BODY SIZE (NOM)
TPS6240x	VSON (10)	3.00 mm x 3.00 mm

(1) For all available packages, see the orderable addendum at the end of the datasheet.

#### Simplified Schematic

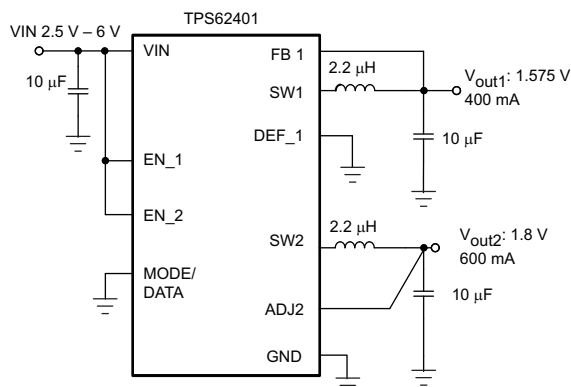

#### Efficiency vs Output Current

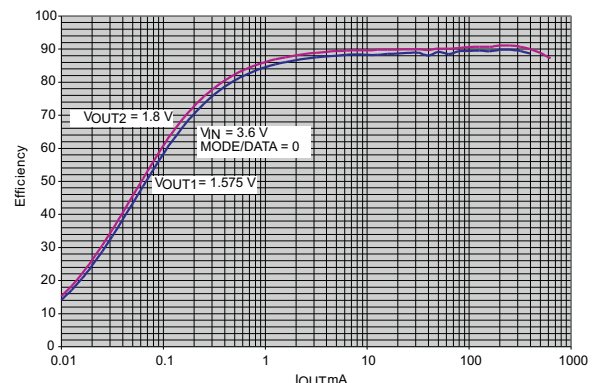

## Table of Contents

<b>1 Features</b> .....	<b>1</b>	8.4 Device Functional Modes .....	<b>13</b>
<b>2 Applications</b> .....	<b>1</b>	8.5 Programming .....	<b>14</b>
<b>3 Description</b> .....	<b>1</b>	<b>9 Application and Implementation</b> .....	<b>22</b>
<b>4 Revision History</b> .....	<b>2</b>	9.1 Application Information .....	<b>22</b>
<b>5 Device Options</b> .....	<b>3</b>	9.2 Typical Applications .....	<b>22</b>
<b>6 Pin Configuration and Functions</b> .....	<b>3</b>	<b>10 Power Supply Recommendations</b> .....	<b>32</b>
<b>7 Specifications</b> .....	<b>4</b>	<b>11 Layout</b> .....	<b>33</b>
7.1 Absolute Maximum Ratings .....	<b>4</b>	11.1 Layout Guidelines .....	<b>33</b>
7.2 Handling Ratings .....	<b>4</b>	11.2 Layout Example .....	<b>33</b>
7.3 Recommended Operating Conditions .....	<b>5</b>	<b>12 Device and Documentation Support</b> .....	<b>35</b>
7.4 Thermal Information .....	<b>5</b>	12.1 Device Support .....	<b>35</b>
7.5 Electrical Characteristics .....	<b>5</b>	12.2 Related Links .....	<b>35</b>
7.6 Typical Characteristics .....	<b>7</b>	12.3 Trademarks .....	<b>35</b>
<b>8 Detailed Description</b> .....	<b>9</b>	12.4 Electrostatic Discharge Caution .....	<b>35</b>
8.1 Overview .....	<b>9</b>	12.5 Glossary .....	<b>35</b>
8.2 Functional Block Diagram .....	<b>10</b>	<b>13 Mechanical, Packaging, and Orderable Information</b> .....	<b>35</b>
8.3 Feature Description .....	<b>11</b>		

## 4 Revision History

### Changes from Revision E (April 2010) to Revision F

Page

- Added *Handling Rating* table, *Feature Description* section, *Device Functional Modes*, *Application and Implementation* section, *Power Supply Recommendations* section, *Layout* section, *Device and Documentation Support* section, and *Mechanical, Packaging, and Orderable Information* section .....

1

### Changes from Revision D (February 2006) to Revision E

Page

- Added TPS62404 device .....
- Added TPS62404 device to Ordering Information table .....
- Added TPS62404 device to Addressable Registers table .....
- Added TPS62404 device to 'Selectable Output Voltages for Converter 1' table .....
- Added TPS62404 device to 'Selectable Output Voltages for Converter 2' table .....
- Added TPS62404 device to 'Application Information' section .....
- Added TPS62404 device efficiency graph ([Figure 22](#)) .....

1

1

15

19

21

23

26

## 5 Device Options

T <sub>A</sub>	PART NUMBER	DEFAULT OUTPUT VOLTAGE <sup>(1)</sup>		OUTPUT CURRENT	
–40 °C to 85 °C	TPS62400	OUT1	Adjustable	400mA	
		OUT2		600mA	
	TPS62401	OUT1	Fixed default	DEF_1 = High 1.1V DEF_1 = Low 1.575V	400mA
		OUT2	Fixed default 1.8V		600mA
	TPS62402	OUT1	Fixed default	DEF_1 = High 1.8V DEF_1 = Low 1.2V	400mA
		OUT2	Fixed default 3.3V		600mA
	TPS62403	OUT1	Fixed default	DEF_1 = High 1.1V DEF_1 = Low 1.575V	400mA
		OUT2	Fixed default 2.8V		600mA
	TPS62404	OUT1	Fixed default	DEF_1 = High 1.9V DEF_1 = Low 1.2V	400mA
		OUT2	Fixed default 3.3V		600mA

(1) Contact TI for other fixed output voltage options.

## 6 Pin Configuration and Functions

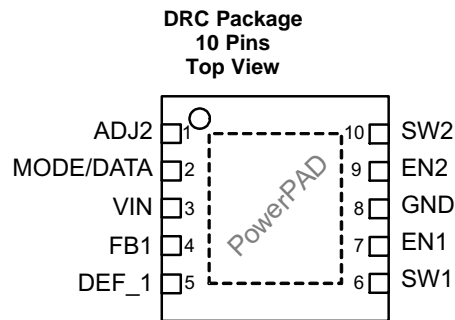

### Pin Functions

PIN		I/O	DESCRIPTION
NAME	NO.		
ADJ2	1	I	Input to adjust output voltage of converter 2. In adjustable version (TPS62400) connect a external resistor divider between VOUT2, this pin and GND to set output voltage between 0.6V and VIN. At fixed output voltage version (TPS62401, TPS62402, TPS62403, TPS62404) this pin MUST be directly connected to the output. If EasyScale Interface is used for converter 2, this pin must be directly connected to the output, too.
DEF_1	5	I	This pin defines the output voltage of converter 1. The pin acts either as analog input for output voltage setting via external resistors (TPS62400), or digital input to select between two fixed default output voltages (TPS62401, TPS62402, TPS62403, TPS62404). For the TPS62400, an external resistor network needs to be connected to this pin to adjust the default output voltage. Using the fixed output voltage device options this pin selects between two fixed default output voltages, see table ordering information
EN1	7	I	Enable Input for Converter1, active high
EN2	9	I	Enable Input for Converter 2, active high
FB1	4	I	Direct feedback voltage sense input of converter 1, connect directly to Vout 1. An internal feed forward capacitor is connected between this pin and the error amplifier. In case of fixed output voltage versions or when the Interface is used, this pin is connected to an internal resistor divider network.
GND	8		GND for both converters; connect this pin to the PowerPAD™

### Pin Functions (continued)

PIN		I/O	DESCRIPTION
NAME	NO.		
MODE/DATA	2	I/O	This Pin has 2 functions: Operation Mode selection: With low level, Power Save Mode is enabled where the device operates in PFM mode at light loads and enters automatically PWM mode at heavy loads. Pulling this PIN to high forces the device to operate in PWM mode over the whole load range. EasyScale™ Interface function: One wire serial interface to change the output voltage of both converters. The pin has an open drain output to provide an acknowledge condition if requested. The current into the open drain output stage may not exceed 500µA. The interface is active if either EN1 or EN2 is high.
PowerPAD™			Connect to GND
SW1	6	I/O	Switch Pin of Converter 1. Connect to Inductor
SW2	10	I/O	Switch Pin of Converter 2. Connect to Inductor.
VIN	3		Supply voltage, connect to VBAT, 2.5V to 6V

## 7 Specifications

### 7.1 Absolute Maximum Ratings

over operating free-air temperature range (unless otherwise noted)<sup>(1)</sup>

	MIN	MAX	UNIT
Input voltage range on V <sub>IN</sub> <sup>(2)</sup>	-0.3	7	V
Voltage range on EN, MODE/DATA, DEF_1	-0.3	V <sub>IN</sub> + 0.3, ≤ 7	V
current into MODE/DATA		≤ 0.5	mA
Voltage on SW1, SW2	-0.3	7	V
Voltage on ADJ2, FB1	-0.3	V <sub>IN</sub> + 0.3, ≤ 7	V
T <sub>J(max)</sub> Maximum operating junction temperature		150	°C
T <sub>A</sub> Operating ambient temperature range	-40	85	°C

- (1) Stresses beyond those listed under *absolute maximum ratings* may cause permanent damage to the device. These are stress ratings only, and functional operation of the device at these or any other conditions beyond those indicated under *recommended operating conditions* is not implied. Exposure to absolute-maximum-rated conditions for extended periods may affect device reliability.
- (2) All voltage values are with respect to network ground terminal.

### 7.2 Handling Ratings

	MIN	MAX	UNIT
T <sub>stg</sub> Storage temperature range	-65	150	°C
V <sub>(ESD)</sub> Electrostatic discharge <sup>(1)</sup>	Human body model (HBM), per ANSI/ESDA/JEDEC JS-001, all pins <sup>(2)</sup>	1	kV
	Charged device model (CDM), per JEDEC specification JESD22-C101, all pins <sup>(3)</sup>	0.5	
	Machine model	200	V

- (1) The human body model is a 100pF capacitor discharged through a 1.5kΩ resistor into each pin. The machine model is a 200pF capacitor discharged directly into each pin.
- (2) JEDEC document JEP155 states that 500-V HBM allows safe manufacturing with a standard ESD control process.
- (3) JEDEC document JEP157 states that 250-V CDM allows safe manufacturing with a standard ESD control process.

### 7.3 Recommended Operating Conditions

over operating free-air temperature range (unless otherwise noted)

		MIN	NOM	MAX	UNIT
V <sub>IN</sub>	Supply voltage	2.5		6	V
V <sub>OUT</sub>	Output voltage range for adjustable voltage	0.6		V <sub>IN</sub>	V
T <sub>A</sub>	Operating ambient temperature	-40		85	°C
T <sub>J</sub>	Operating junction temperature	-40		125	°C

### 7.4 Thermal Information

THERMAL METRIC <sup>(1)</sup>		TPS6240x	UNIT
		VSON	
		10 PINS	
R <sub>θJA</sub>	Junction-to-ambient thermal resistance	45.9	°C/W
R <sub>θJC(top)</sub>	Junction-to-case (top) thermal resistance	64.3	
R <sub>θJB</sub>	Junction-to-board thermal resistance	20.4	
Ψ <sub>JT</sub>	Junction-to-top characterization parameter	1.3	
Ψ <sub>JB</sub>	Junction-to-board characterization parameter	20.6	
R <sub>θJC(bot)</sub>	Junction-to-case (bottom) thermal resistance	2.8	

(1) For more information about traditional and new thermal metrics, see the *IC Package Thermal Metrics* application report, [SPRA953](#).

### 7.5 Electrical Characteristics

V<sub>IN</sub> = 3.6V, V<sub>OUT</sub> = 1.8V, EN = V<sub>IN</sub>, MODE = GND, L = 2.2μH, C<sub>OUT</sub> = 20μF, T<sub>A</sub> = -40°C to 85°C typical values are at T<sub>A</sub> = 25°C (unless otherwise noted)

PARAMETER		TEST CONDITIONS	MIN	TYP	MAX	UNIT
<b>SUPPLY CURRENT</b>						
V <sub>IN</sub>	Input voltage range		2.5		6.0	V
I <sub>Q</sub>	Operating quiescent current	One converter, I <sub>OUT</sub> = 0mA. PFM mode enabled (Mode = 0) device not switching, EN1 = 1 OR EN2 = 1		19	29	μA
		Two converter, I <sub>OUT</sub> = 0mA. PFM mode enabled (Mode = 0) device not switching, EN1 = 1 AND EN2 = 1		32	48	μA
		I <sub>OUT</sub> = 0mA, MODE/DATA = GND, for one converter, V <sub>OUT</sub> 1.575V <sup>(1)</sup>		23		μA
		I <sub>OUT</sub> = 0mA, MODE/DATA = V <sub>IN</sub> , for one converter, V <sub>OUT</sub> 1.575V <sup>(1)</sup>		3.6		mA
I <sub>SD</sub>	Shutdown current	EN1, EN2 = GND, V <sub>IN</sub> = 3.6V <sup>(2)</sup>		1.2	3	μA
		EN1, EN2 = GND, V <sub>IN</sub> ramped from 0V to 3.6V <sup>(3)</sup>		0.1	1	
V <sub>UVLO</sub>	Undervoltage lockout threshold	Falling		1.5	2.35	V
		Rising			2.4	
<b>ENABLE EN1, EN2</b>						
V <sub>IH</sub>	High-level input voltage range, EN1, EN2		1.2		V <sub>IN</sub>	V
V <sub>IL</sub>	Low-level input voltage range, EN1, EN2		0		0.4	V
I <sub>IN</sub>	Input bias current, EN1, EN2	EN1, EN2 = GND or V <sub>IN</sub>		0.05	1.0	μA

(1) Device is switching with no load on the output, L = 3.3μH, value includes losses of the coil

(2) These values are valid after the device has been already enabled one time (EN1 or EN2 = high) and supply voltage V<sub>IN</sub> has not powered down.

(3) These values are valid when the device is disabled (EN1 and EN2 low) and supply voltage V<sub>IN</sub> is powered up. The values remain valid until the device has been enabled first time (EN1 or EN2 = high). After first enable, Note 3 becomes valid.

## Electrical Characteristics (continued)

$V_{IN} = 3.6V$ ,  $V_{OUT} = 1.8V$ ,  $EN = V_{IN}$ ,  $MODE = GND$ ,  $L = 2.2\mu H$ ,  $C_{OUT} = 20\mu F$ ,  $T_A = -40^\circ C$  to  $85^\circ C$  typical values are at  $T_A = 25^\circ C$  (unless otherwise noted)

PARAMETER		TEST CONDITIONS	MIN	TYP	MAX	UNIT	
<b>DEF_1 INPUT</b>							
$V_{DEF\_1H}$	DEF_1 high level input voltage range	$V_{OUT1} = \text{fixed output voltage option}$	0.9		$V_{IN}$	V	
$V_{DEF\_1L}$	DEF_1 low level input voltage range	$V_{OUT1} = \text{fixed output voltage option}$	0		0.4	V	
$I_{IN}$	Input bias current DEF_1	DEF_1 GND or $V_{IN}$		0.01	1.0	$\mu A$	
<b>MODE/DATA</b>							
$V_{IH}$	High-level input voltage range, MODE/DATA		1.2		$V_{IN}$	V	
$V_{IL}$	Low-level input voltage range, MODE/DATA		0		0.4	V	
$I_{IN}$	Input bias current, MODE/DATA	MODE/DATA = GND or $V_{IN}$		0.01	1.0	$\mu A$	
$V_{OH}$	Acknowledge output voltage high	Open drain, via external pullup resistor			$V_{IN}$	V	
$V_{OL}$	Acknowledge output voltage low	Open drain, sink current 500 $\mu A$	0		0.4	V	
<b>INTERFACE TIMING</b>							
$t_{Start}$	Start time		2			$\mu s$	
$t_{H\_LB}$	High time low bit, logic 0 detection	Signal level on MODE/DATA pin is > 1.2V	2		200	$\mu s$	
$t_{L\_LB}$	Low time low bit, logic 0 detection	Signal level on MODE/DATA pin < 0.4V	$2x$ $t_{H\_LB}$		400	$\mu s$	
$t_{L\_HB}$	Low time high bit, logic 1 detection	Signal level on MODE/DATA pin < 0.4V	2		200	$\mu s$	
$t_{H\_HB}$	High time high bit, logic 1 detection	Signal level on MODE/DATA pin is > 1.2V	$2x$ $t_{L\_HB}$		400	$\mu s$	
$T_{EOS}$	End of Stream	$T_{EOS}$	2			$\mu s$	
$t_{ACKN}$	Duration of acknowledge condition (MODE/DATA line pulled low by the device)	$V_{IN} 2.5V$ to 6V	400		520	$\mu s$	
$t_{valACK}$	Acknowledge valid time				2	$\mu s$	
$t_{timeout}$	Timeout for entering power save mode	MODE/DATA Pin changes from high to low			520	$\mu s$	
<b>POWER SWITCH</b>							
$R_{DS(ON)}$	P-Channel MOSFET on-resistance, Converter 1,2	$V_{IN} = V_{GS} = 3.6V$		280	620	m $\Omega$	
$I_{LK\_PMOS}$	P-Channel leakage current	$V_{DS} = 6.0V$			1	$\mu A$	
$R_{DS(ON)}$	N-Channel MOSFET on-resistance Converter 1,2	$V_{IN} = V_{GS} = 3.6V$		200	450	m $\Omega$	
$I_{LK\_SW1/SW2}$	Leakage current into SW1/SW2 pin	Includes N-Channel leakage current, $V_{IN} = \text{open}$ , $V_{SW} = 6.0V$ , $EN = GND^{(4)}$		6	7.5	$\mu A$	
$I_{LIMF}$	Forward Current Limit PMOS and NMOS	OUTPUT 1	$2.5V \leq V_{IN} \leq 6.0V$	0.68	0.8	0.92	A
		OUTPUT 2		0.85	1.0	1.15	
$T_{SD}$	Thermal shutdown	Increasing junction temperature		150		$^\circ C$	
	Thermal shutdown hysteresis	Decreasing junction temperature		20		$^\circ C$	
<b>OSCILLATOR</b>							
fSW	Oscillator frequency	$2.5V \leq V_{IN} \leq 6V$	2.0	2.25	2.5	MHz	

(4) On pins SW1 and SW2 an internal resistor of 1M $\Omega$  is connected to GND.

**Electrical Characteristics (continued)**

$V_{IN} = 3.6V$ ,  $V_{OUT} = 1.8V$ ,  $EN = V_{IN}$ ,  $MODE = GND$ ,  $L = 2.2\mu H$ ,  $C_{OUT} = 20\mu F$ ,  $T_A = -40^\circ C$  to  $85^\circ C$  typical values are at  $T_A = 25^\circ C$  (unless otherwise noted)

PARAMETER		TEST CONDITIONS	MIN	TYP	MAX	UNIT
<b>OUTPUT</b>						
$V_{OUT}$	Adjustable output voltage range		0.6		$V_{IN}$	V
$V_{ref}$	Reference voltage			600		mV
$V_{OUT(PFM)}$	DC output voltage accuracy adjustable and fixed output voltage <sup>(5)</sup>	Voltage positioning active, $MODE/DATA = GND$ , device operating in PFM mode, $V_{IN} = 2.5V$ to $5.0V$ <sup>(6) (7)</sup>	-1.5%	1.01 $V_{OUT}$	2.5%	
$V_{OUT(PWM)}$		$MODE/DATA = GND$ ; device operating in PWM Mode, $V_{IN} = 2.5V$ to $6.0V$ <sup>(7)</sup>	-1%	0%	1%	
		$V_{IN} = 2.5V$ to $6.0V$ , $Mode/Data = V_{IN}$ , Fixed PWM operation, $0mA < I_{OUT1} < 400mA$ ; $0mA < I_{OUT2} < 600mA$ <sup>(8)</sup>	-1%	0%	1%	
	DC output voltage load regulation	PWM operation mode			0.5	%/A
$t_{Start up}$	Start-up time	Activation time to start switching <sup>(9)</sup>		170		$\mu s$
$t_{Ramp}$	$V_{OUT}$ Ramp UP time	Time to ramp from 5% to 95% of $V_{OUT}$		750		$\mu s$

- (5) Output voltage specification does not include tolerance of external voltage programming resistors
- (6) Configuration L typ  $2.2\mu H$ ,  $C_{OUT}$  typ  $20\mu F$ , see parameter measurement information, the output voltage ripple in PFM mode depends on the effective capacitance of the output capacitor, larger output capacitors lead to tighter output voltage tolerance.
- (7) In Power Save Mode, PWM operation is typically entered at  $I_{PSM} = V_{IN}/32\Omega$ .
- (8) For  $V_{OUT} > 2V$ ,  $V_{IN min} = V_{OUT} + 0.5V$
- (9) This time is valid if one converter turns from shutdown mode ( $EN2 = 0$ ) to active mode ( $EN2 = 1$ ) AND the other converter is already enabled (e.g.,  $EN1 = 1$ ). In case both converters are turned from shutdown mode ( $EN1$  and  $EN2 = low$ ) to active mode ( $EN1$  and/or  $EN2=1$ ) a value of typ  $80 \mu s$  for ramp up of internal circuits needs to be added. After  $t_{Start}$  the converter starts switching and ramps  $V_{OUT}$ .

**7.6 Typical Characteristics**

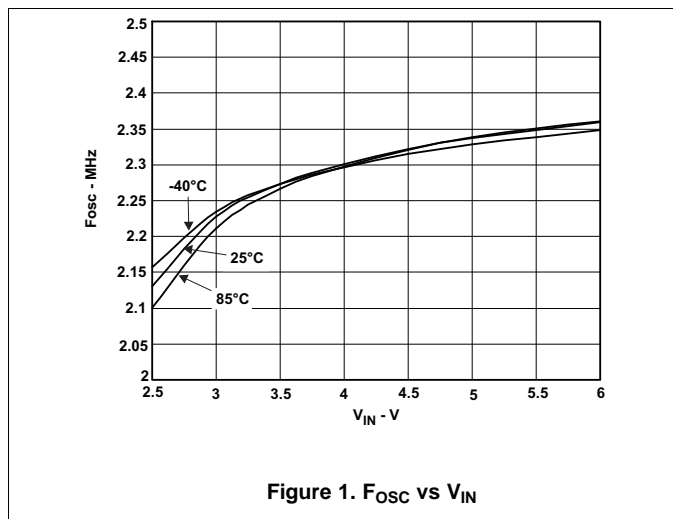

Figure 1. Fosc vs VIN

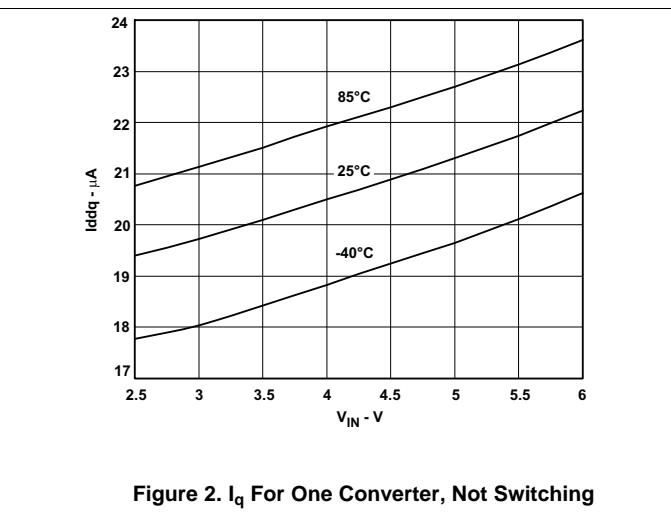

Figure 2. Iq For One Converter, Not Switching

Typical Characteristics (continued)

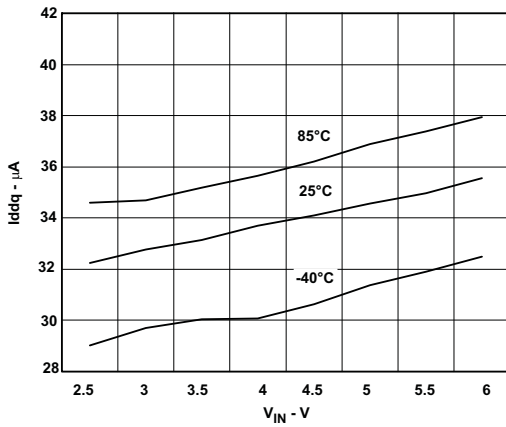

Figure 3. I<sub>q</sub> For Both Converters, Not Switching

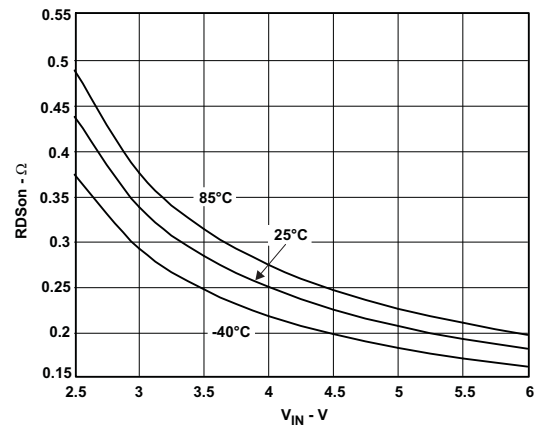

Figure 4. R<sub>DSON</sub> PMOS vs V<sub>IN</sub>

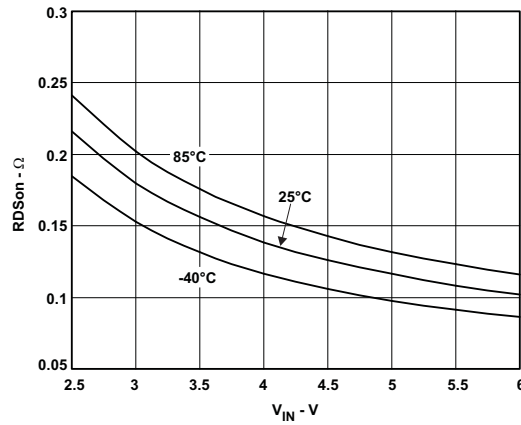

Figure 5. R<sub>DSON</sub> NMOS vs V<sub>IN</sub>

## 8 Detailed Description

### 8.1 Overview

The TPS62400 includes two synchronous step-down converters. The converters operate with typically 2.25MHz fixed frequency pulse width modulation (PWM) at moderate to heavy load currents. If Power Safe Mode is enabled, the converters automatically enter Power Save Mode at light load currents and operate in PFM (Pulse Frequency Modulation).

During PWM operation the converters use a unique fast response voltage mode controller scheme with input voltage feed-forward to achieve good line and load regulation allowing the use of small ceramic input and output capacitors. At the beginning of each clock cycle initiated by the clock signal, the P-channel MOSFET switch is turned on and the inductor current ramps up until the comparator trips and the control logic turns off the switch.

Each converter integrates two current limits, one in the P-channel MOSFET and another one in the N-channel MOSFET. When the current in the P-channel MOSFET reaches its current limit, the P-channel MOSFET is turned off and the N-channel MOSFET is turned on. If the current in the N-channel MOSFET is above the N-MOS current limit threshold, the N-channel MOSFET remains on until the current drops below its current limit.

The two DC-DC converters operate synchronized to each other. A 180° phase shift between converter 1 and converter 2 decreases the input RMS current.

## 8.2 Functional Block Diagram

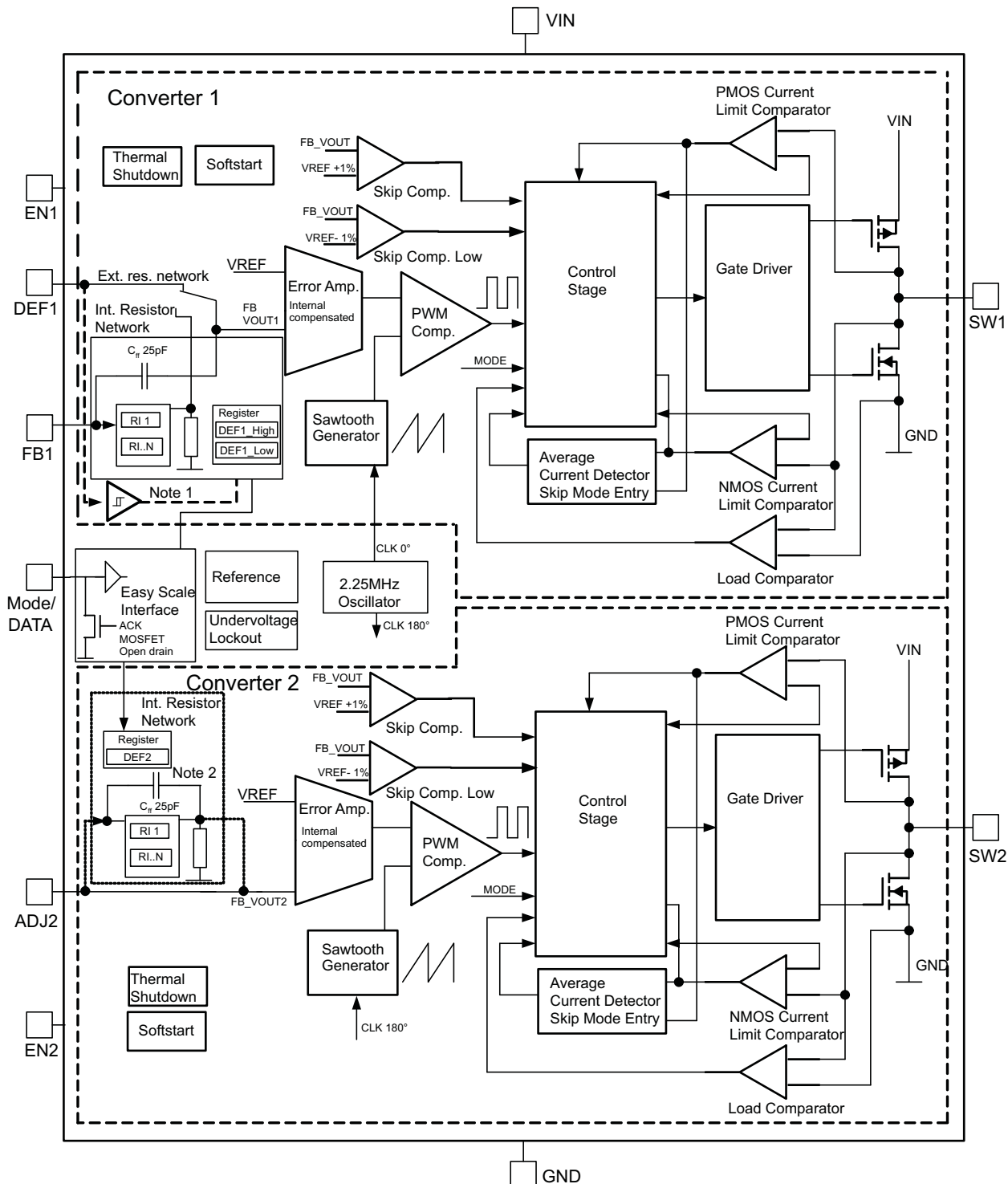

- (1) In fixed output voltage version, the PIN DEF\_1 is connected to an internal digital input and disconnected from the error amplifier
- (2) To set the output voltage of Converter 2 via EasyScale™ Interface, ADJ2 pin must be directly connected to VOUT2

## 8.3 Feature Description

### 8.3.1 Converter 1

In the adjustable output voltage version TPS62400, the converter 1 default output voltage can be set via an external resistor network on PIN DEF\_1, which operates as an analog input. In this case, the output voltage can be set in the range of 0.6V to  $V_{IN}$ . The FB1 Pin must be directly connected to the converter 1 output voltage  $V_{OUT1}$ . It feeds back the output voltage directly to the regulation loop.

The output voltage of converter 1 can also be changed by the EasyScale™ serial Interface. This makes the device very flexible for output voltage adjustment. In this case, the device uses an internal resistor network.

In the fixed default output voltage version TPS62401, the DEF\_1 Pin is configured as a digital input. The converter 1 defaults to 1.1V or **1.575V** depending on the level of DEF\_1 pin. If DEF\_1 is low the default is **1.575V**; if high, the default is **1.1V**. With the EasyScale™ interface, the output voltage for each DEF\_1 Pin condition (high or low) can be changed.

### 8.3.2 Converter 2

In the adjustable output voltage version TPS62400, the converter 2 output voltage is set by an external resistor divider connected to ADJ2 Pin and uses an external feed forward capacitor of 33pF.

In fixed output voltage version TPS62401, the default output voltage is fixed to 1.8V. In this case, the ADJ2 pin must be connected directly to the converter 2 output voltage  $V_{OUT2}$ .

It is also possible to change the output voltage of converter 2 via the EasyScale™ Interface. In this case, the ADJ2 Pin must be directly connected to converter 2 output voltage  $V_{OUT2}$  and no external resistors may be connected.

### 8.3.3 DEF\_1 Pin Function

The DEF\_1 pin is dedicated to converter 1 and makes the output voltage selection very flexible to support dynamic voltage management.

Depending on the device version, this pin works either as:

1. Analog input for adjustable output voltage setting (TPS62400):
  - Connecting an external resistor network to this pin adjusts the default output voltage to any value starting from 0.6V to  $V_{IN}$
2. Digital input for fixed default output voltage selection (TPS62401):
  - In case this pin is tied to low level, the output voltage is set according to the value in register REG\_DEF\_1\_Low. The default voltage will be **1.575V**. If tied to high level, the output voltage is set according to the value in register REG\_DEF\_1\_High. The default value in this case is **1.1V**. Depending on the level of Pin DEF\_1, it selects between the two registers REG\_DEF\_1\_Low and REG\_DEF\_1\_High for output voltage setting. Each register content (and therefore output voltage) can be changed individually via the EasyScale™ interface. This makes the device very flexible in terms of output voltage setting; see [Table 4](#).

### 8.3.4 Mode Selection

The MODE/DATA pin allows mode selection between forced PWM Mode and Power Save Mode for both converters. Furthermore, this pin is a multipurpose pin and provides (besides Mode selection) a one-pin interface to receive serial data from a host to set the output voltage. This is described in the EasyScale™ Interface section.

Connecting this pin to GND enables the automatic PWM and power save mode operation. The converters operates in fixed-frequency PWM mode at moderate-to-heavy loads, and in the PFM mode during light loads, maintaining high efficiency over a wide load current range.

Pulling the MODE/DATA pin high forces both converters to operate constantly in the PWM mode, even at light load currents. The advantage is that the converters operate with a fixed frequency, allowing simple filtering of the switching frequency for noise-sensitive applications. In this mode, the efficiency is lower compared to the power save mode during light loads. For additional flexibility, it is possible to switch from power save mode to forced PWM mode during operation. This allows efficient power management by adjusting the operation of the converter to the specific system requirements.

## Feature Description (continued)

In case the operation mode is changed from forced PWM mode (MODE/DATA = high) to Power Save Mode Enable (MODE/DATA = 0), the Power Save Mode is enabled after a delay time of  $t_{\text{timeout}}$ , which is max. 520 $\mu$ s.

The forced PWM Mode operation is enabled immediately with Pin MODE/DATA set to 1.

### 8.3.5 Enable

The device has a separate EN pin for each converter to start up each converter independently. If EN1 and EN2 are set to high, the corresponding converter starts up with soft start as previously described.

Pulling EN1 and EN2 pin low forces the device into shutdown, with a shutdown quiescent current of typically 1.2 $\mu$ A. In this mode, the P and N-Channel MOSFETs are turned-off and the entire internal control circuitry is switched-off. For proper operation the EN1 and EN2 pins must be terminated and must not be left floating.

### 8.3.6 Soft Start

The two converters have an internal soft start circuit that limits the inrush current during start-up. During soft start, the output voltage ramp up is controlled as shown in Figure 6.

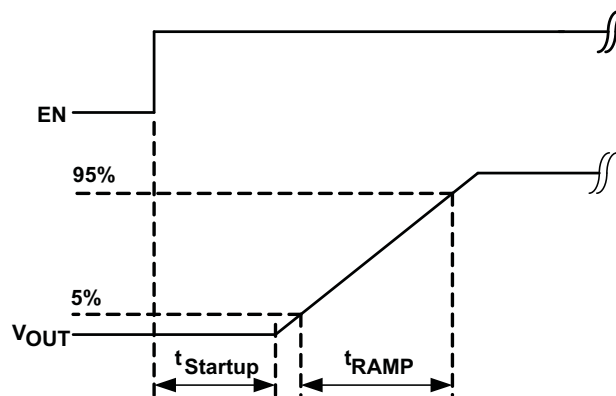

Figure 6. Soft Start

### 8.3.7 Short-Circuit Protection

Both outputs are short-circuit protected with maximum output current =  $I_{\text{LIMF}}$  (P-MOS and N-MOS). Once the PMOS switch reaches its current limit, it is turned off and the NMOS switch is turned on. The PMOS only turns on again, once the current in the NMOS decreases below the NMOS current limit.

### 8.3.8 Under-Voltage Lockout

The under-voltage lockout circuit prevents the device from malfunctioning at low input voltages, and from excessive discharge of the battery, and disables the converters. The under-voltage lockout threshold is typically 1.5V; maximum of 2.35V. In case the default register values are overwritten by the Interface, the new values in the registers REG\_DEF\_1\_High, REG\_DEF\_1\_Low and REG\_DEF\_2 remain valid as long the supply voltage does not fall below the under-voltage lockout threshold, independent of whether the converters are disabled.

### 8.3.9 Thermal Shutdown

As soon as the junction temperature,  $T_J$ , exceeds 150°C (typical) the device goes into thermal shutdown. In this mode, the P and N-Channel MOSFETs are turned-off. The device continues its operation when the junction temperature falls below the thermal shutdown hysteresis.

## 8.4 Device Functional Modes

### 8.4.1 Power Save Mode

The Power Save Mode is enabled with MODE/DATA Pin set to low for both converters. If the load current of a converter decreases, this converter will enter Power Save Mode operation automatically. The transition to Power Save Mode of a converter is independent from the operating condition of the other converter. During Power Save Mode the converter operates with reduced switching frequency in PFM mode and with a minimum quiescent current to maintain high efficiency. The converter will position the output voltage in PFM mode to typically  $1.01 \times V_{OUT}$ . This voltage positioning feature minimizes voltage drops caused by a sudden load step.

In order to optimize the converter efficiency at light load the average inductor current is monitored. The device changes from PWM Mode to Power Save Mode, if in PWM mode the inductor current falls below a certain threshold. The typical output current threshold depends on VIN and can be calculated according to [Equation 1](#) for each converter.

**Equation 1:** Average output current threshold to enter PFM Mode

$$I_{OUT\_PFM\_enter} = \frac{V_{IN\_DCDC}}{32 \Omega} \quad (1)$$

**Equation 2:** Average output current threshold to leave PFM Mode

$$I_{OUT\_PFM\_leave} = \frac{V_{IN\_DCDC}}{24 \Omega} \quad (2)$$

In order to keep the output voltage ripple in Power Save Mode low, the output voltage is monitored with a single threshold comparator (skip comparator). As the output voltage falls below the skip comparator threshold (skip comp) of  $1.01 \times V_{OUTnominal}$ , the corresponding converter starts switching for a minimum time period of typ.  $1 \mu s$  and provides current to the load and the output capacitor. Therefore the output voltage will increase and the device maintains switching until the output voltage trips the skip comparator threshold (skip comp) again. At this moment all switching activity is stopped and the quiescent current is reduced to minimum. The load is supplied by the output capacitor until the output voltage has dropped below the threshold again. Hereupon the device starts switching again.

The Power Save Mode is left and PWM Mode entered in case the output current exceeds the current  $I_{OUT\_PFM\_leave}$  or if the output voltage falls below a second comparator threshold, called skip comparator low (Skip Comp Low) threshold. This skip comparator low threshold is set to -2% below nominal Vout, and enables a fast transition from Power Save Mode to PWM Mode during a load step.

In Power Save Mode the quiescent current is reduced typically to  $19 \mu A$  for one converter and  $32 \mu A$  for both converters active. This single skip comparator threshold method in Power Save Mode results in a very low output voltage ripple. The ripple depends on the comparator delay and the size of the output capacitor. Increasing output capacitor values will minimize the output ripple. The Power Save Mode can be disabled through the MODE/DATA pin set to high. Both converters will then operate in fixed PWM mode. Power Save Mode Enable/Disable applies to both converters.

### 8.4.2 Dynamic Voltage Positioning

This feature reduces the voltage under/overshoots at load steps from light to heavy load and vice versa. It is activated in Power Save Mode operation. It provides more headroom for both the voltage drop at a load step, and the voltage increase at a load throw-off. This improves load transient behavior.

At light loads, in which the converter operates in PFM Mode, the output voltage is regulated typically 1% higher than the nominal value. In case of a load transient from light load to heavy load, the output voltage drops until it reaches the skip comparator low threshold set to -2% below the nominal value and enters PWM mode. During a load throw off from heavy load to light load, the voltage overshoot is also minimized due to active regulation turning on the N-channel switch.

## Device Functional Modes (continued)

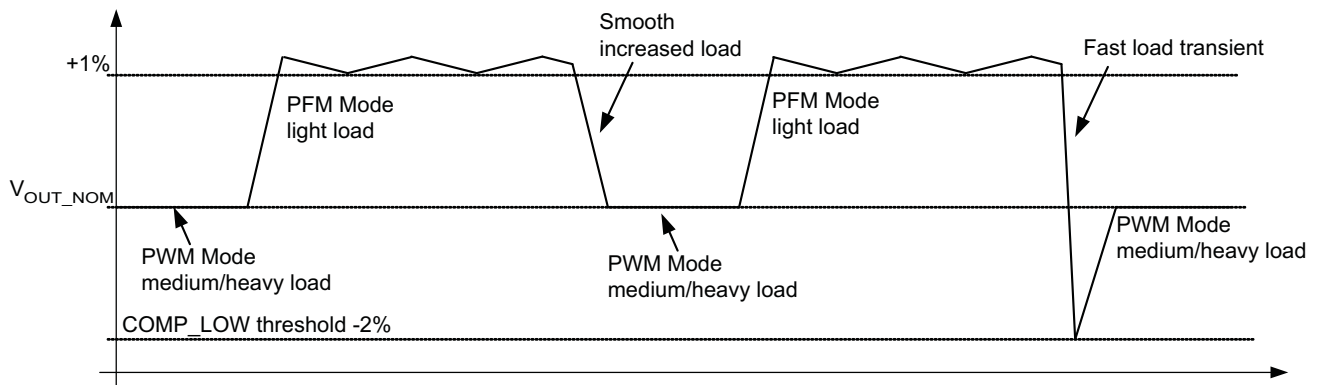

Figure 7. Dynamic Voltage Positioning

### 8.4.3 100% Duty Cycle Low Dropout Operation

The converters offer a low input-to-output voltage difference while still maintaining operation with the use of the 100% duty cycle mode. In this mode the P-channel switch is constantly turned on. This is particularly useful in battery-powered applications to achieve longest operation time by taking full advantage of the whole battery voltage range. The minimum input voltage to maintain regulation depends on the load current and output voltage, and can be calculated as:

$$V_{in\_min} = V_{out\_max} + I_{out\_max} \times (R_{DSon\_max} + R_L) \quad (3)$$

with:

$I_{out\_max}$  = maximum output current plus inductor ripple current

$R_{DSon\_max}$  = maximum P-channel switch  $R_{DSon}$ .

$R_L$  = DC resistance of the inductor

$V_{out\_max}$  = nominal output voltage plus maximum output voltage tolerance

With decreasing load current, the device automatically switches into pulse skipping operation in which the power stage operates intermittently based on load demand. By running cycles periodically the switching losses are minimized and the device runs with a minimum quiescent current, maintaining high efficiency.

### 8.4.4 180° Out-Of-Phase Operation

In PWM Mode the converters operate with a 180° turn-on phase shift of the PMOS (high side) transistors. This prevents the high-side switches of both converters from being turned on simultaneously, and therefore smooths the input current. This feature reduces the surge current drawn from the supply.

## 8.5 Programming

### 8.5.1 EasyScale™: One-Pin Serial Interface for Dynamic Output Voltage Adjustment

#### 8.5.1.1 General

EasyScale is a simple but very flexible one pin interface to configure the output voltage of both DC-DC converters. The interface is based on a master – slave structure, where the master is typically a microcontroller or application processor. Figure 8 and Table 3. give an overview of the protocol. The protocol consists of a device specific address byte and a data byte. The device specific address byte is fixed to 4E hex. The data byte consists of five bits for information, two address bits, and the RFA bit. RFA bit set to high indicates the Request For Acknowledge condition. The Acknowledge condition is only applied if the protocol was received correctly.

The advantage of EasyScale™ compared to other one pin interfaces is that its bit detection is in a large extent independent from the bit transmission rate. It can automatically detect bit rates between 1.7kBit/sec and up to 160kBit/sec. Furthermore, the interface is shared with the MODE/DATA Pin and requires no additional pin.

## Programming (continued)

### 8.5.1.2 Protocol

All bits are transmitted MSB first and LSB last. [Figure 9](#) shows the protocol without acknowledge request (bit RFA = 0), [Figure 10](#) with acknowledge (bit RFA = 1) request.

Prior to both bytes, device address byte and data byte, a start condition needs to be applied. For this, the MODE/DATA pin need be pulled high for at least  $t_{\text{start}}$  before the bit transmission starts with the falling edge. In case the MODE/DATA line was already at high level (forced PWM Mode selection), no start condition need be applied prior the device address byte.

The transmission of each byte needs to be closed with an End Of Stream condition for at least  $T_{\text{EOS}}$ .

### 8.5.1.3 Addressable Registers

Three registers with a data content of 5 bits can be addressed. With 5 bit data content, 32 different values for each register are available. [Table 1](#) shows the addressable registers to set the output voltage when DEF\_1 pin works as digital input. In this case, converter 1 has a related register for each DEF\_1 Pin condition, and one register for converter 2. With a high/low condition on pin DEF\_1 (TPS62401) either the content of register REG\_DEF\_1\_high/REG\_DEF1\_low is selected. The output voltage of converter 1 is set according to the values in [Table 4](#).

[Table 2](#) shows the addressable registers if DEF\_1 pin acts as analog input with external resistors connected. In this case one register is available for each converter. The output voltage of converter 1 is set according to the values in [Table 5](#). For converter 2, the available voltages are shown in [Table 6](#). To generate these output voltages a precise internal resistor divider network is used, making external resistors unnecessary (less board space), and provides higher output voltage accuracy. The Interface is activated if at least one of the converters is enabled (EN1 or EN2 is high). After the startup-time  $t_{\text{start}}$  (170 $\mu$ s) the interface is ready for data reception.

**Table 1. Addressable Registers for default Fixed Output Voltage Options (PIN DEF\_1 = digital input)**

DEVICE	REGISTER	DESCRIPTION	DEF_1 PIN	A1	A0	D4	D3	D2	D1	D0
TPS62401, TPS62402, TPS62403, TPS62404	REG_DEF_1_High	Converter 1 output voltage setting for DEF_1 = High condition. The content of the register is active with DEF1_ Pin high.	High	0	1	Output voltage setting, see <a href="#">Table 4</a>				
	REG_DEF_1_Low	Converter 1 output voltage setting for DEF_1 = Low condition.	Low	0	0	Output voltage setting, see <a href="#">Table 4</a>				
	REG_DEF_2	Converter 2 output voltage	Not applicable	1	0	Output voltage setting, see <a href="#">Table 6</a>				
		Don't use		1	1					

**Table 2. Addressable Registers for Adjustable Output Voltage Options (PIN DEF\_1 = analog input)**

DEVICE	REGISTER	DESCRIPTION	A1	A0	D4	D3	D2	D1	D0
TPS62400	REG_DEF_1_High	not available							
	REG_DEF_1_Low	Converter 1 output voltage setting	0	0	see <a href="#">Table 5</a>				
	REG_DEF_2	Converter 2 output voltage	1	0	see <a href="#">Table 6</a>				
		Don't use	1	1					

#### 8.5.1.3.1 Bit Decoding

The bit detection is based on a PWM scheme, where the criterion is the relation between  $t_{\text{LOW}}$  and  $t_{\text{HIGH}}$ . It can be simplified to:

High Bit:  $t_{\text{High}} > t_{\text{Low}}$ , but with  $t_{\text{High}}$  at least  $2x t_{\text{Low}}$ , see [Figure 34](#)

Low Bit:  $t_{\text{Low}} > t_{\text{High}}$ , but with  $t_{\text{Low}}$  at least  $2x t_{\text{High}}$ , see [Figure 34](#)

The bit detection starts with a falling edge on the MODE/DATA pin and ends with the next falling edge. Depending on the relation between  $t_{\text{Low}}$  and  $t_{\text{High}}$  a 0 or 1 is detected.

### 8.5.1.3.2 Acknowledge

The Acknowledge condition is only applied if:

- Acknowledge is requested by a set RFA bit
- The transmitted device address matches with the device address of the device
- 16 bits were received correctly

In this case, the device turns on the internal ACKN-MOSFET and pulls the MODE/DATA pin low for the time  $t_{ACKN}$ , which is 520 $\mu$ s maximum. The Acknowledge condition is valid after an internal delay time  $t_{valACK}$ . This means the internal ACKN-MOSFET is turned on after  $t_{valACK}$ , when the last falling edge of the protocol was detected. The master controller keeps the line low during this time.

The master device can detect the acknowledge condition with its input by releasing the MODE/DATA pin after  $t_{valACK}$  and read back a 0.

In case of an invalid device address, or not-correctly-received protocol, no-acknowledge condition is applied; thus, the internal MOSFET is not turned on and the external pullup resistor pulls MODE/DATA pin high after  $t_{valACK}$ . The MODE/DATA pin can be used again after the acknowledge condition ends.

#### NOTE

The acknowledge condition may only be requested in case the master device has an open drain output.

In case of a push-pull output stage it is recommended to use a series resistor in the MODE/DATA line to limit the current to 500  $\mu$ A in case of an accidentally requested acknowledge, to protect the internal ACKN-MOSFET.

### 8.5.1.3.3 MODE Selection

Because the MODE/DATA pin is used for two functions, interface and a MODE selection, the device needs to determine when it has to decode the bit stream or to change the operation mode.

The device enters forced PWM mode operation immediately whenever the MODE/DATA pin turns to high level. The device also stays in forced PWM mode during the entire protocol reception time.

With a falling edge on the MODE/DATA pin the device starts bit decoding. If the MODE/DATA pin stays low for at least  $t_{timeout}$ , the device gets an internal timeout and Power Save Mode operation is enabled.

A protocol sent within this time is ignored because the falling edge for the Mode change is first interpreted as start of the first bit. In this case it is recommended to send the protocol first, and then change at the end of the protocol to Power Save Mode.

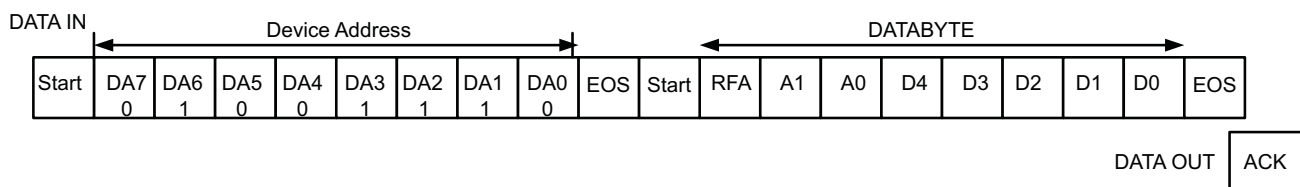

Figure 8. EasyScale™ Protocol Overview

Table 3. EasyScale™ Bit Description

BYTE	BIT NUMBER	NAME	TRANSMISSION DIRECTION	DESCRIPTION	
Device Address Byte	7	DA7	IN	0 MSB device address	
	6	DA6	IN	1	
	5	DA5	IN	0	
	4	DA4	IN	0	
	4Ehex	3	DA3	IN	1
		2	DA2	IN	1
		1	DA1	IN	1
		0	DA0	IN	0 LSB device address
Databyte	7(MSB)	RFA	IN	Request For Acknowledge, if high, Acknowledge condition will applied by the device	
	6	A1		Address Bit 1	
	5	A0		Address Bit 0	
	4	D4		Data Bit 4	
	3	D3		Data Bit 3	
	2	D2		Data Bit 2	
	1	D1		Data Bit 1	
	0(LSB)	D0		Data Bit 0	
		ACK	OUT	Acknowledge condition active 0, this condition will only be applied in case RFA bit is set. Open drain output, Line needs to be pulled high by the host with a pullup resistor.  This feature can only be used if the master has an open drain output stage. In case of a push pull output stage Acknowledge condition may not be requested!	

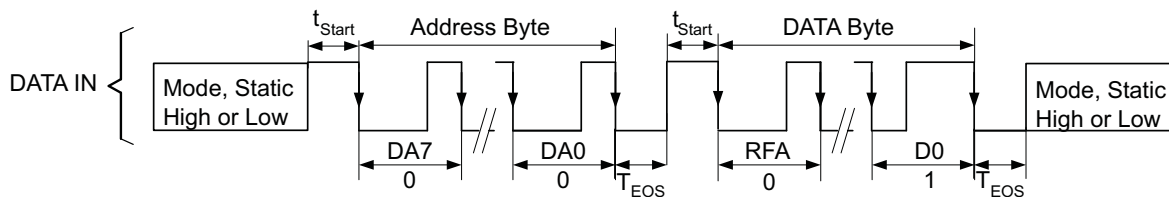

Figure 9. EasyScale™ Protocol Without Acknowledge

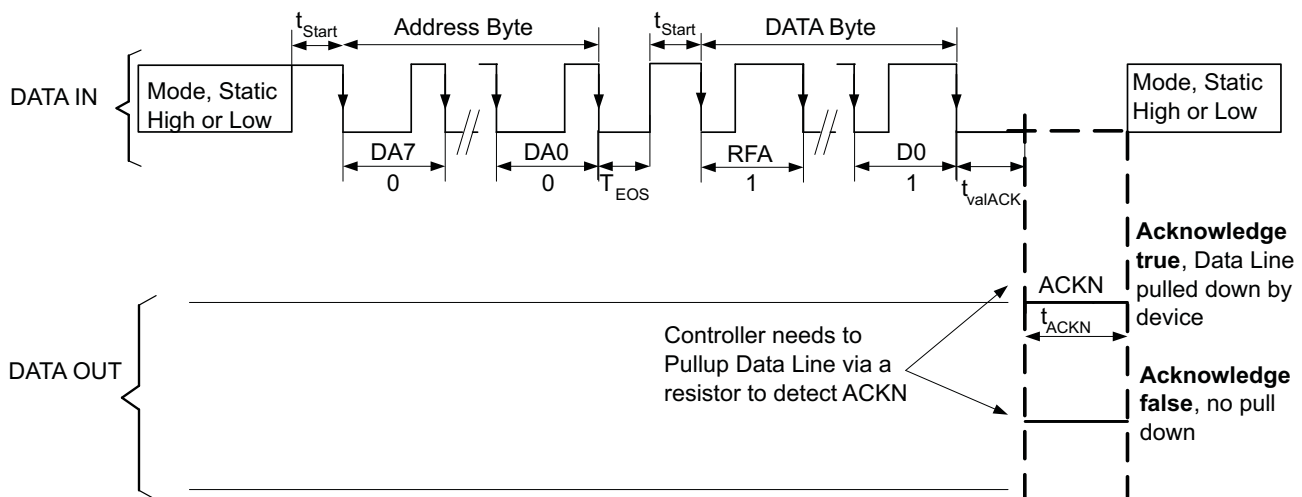

Figure 10. EasyScale™ Protocol Including Acknowledge

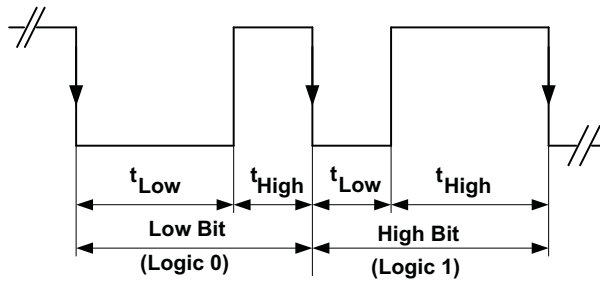

Figure 11. EasyScale™ – Bit Coding

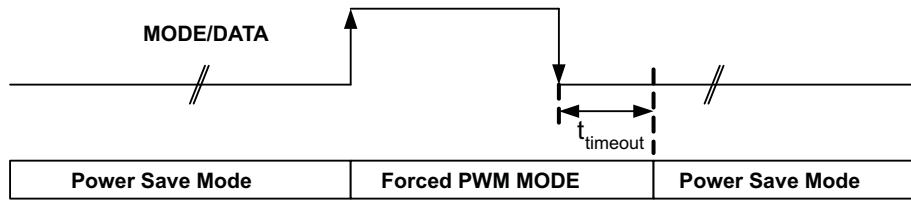

Figure 12. MODE/DATA PIN: Mode Selection

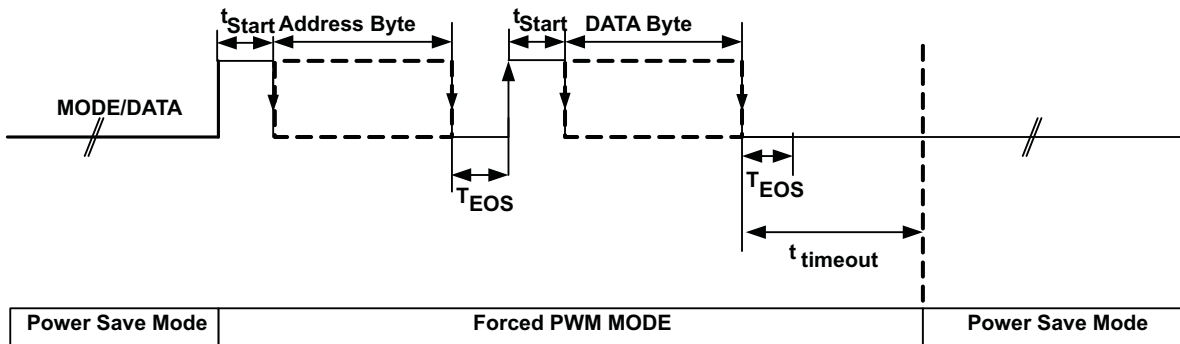

Figure 13. MODE/DATA Pin: Power Save Mode/Interface Communication

**Table 4. Selectable Output Voltages for Converter 1,  
With Pin DEF\_1 as Digital Input (TPS62401)**

	TPS62401 OUTPUT VOLTAGE [V] REGISTER REG_DEF_1_LOW	TPS62401 OUTPUT VOLTAGE [V] REGISTER REG_DEF_1_HIGH	D4	D3	D2	D1	D0
0	0.8	0.9	0	0	0	0	0
1	0.825	0.925	0	0	0	0	1
2	0.85	0.95	0	0	0	1	0
3	0.875	0.975	0	0	0	1	1
4	0.9	1.0	0	0	1	0	0
5	0.925	1.025	0	0	1	0	1
6	0.95	1.050	0	0	1	1	0
7	0.975	1.075	0	0	1	1	1
<b>8</b>	1.0	<b>1.1(default TPS62401, TPS62403)</b>	<b>0</b>	<b>1</b>	<b>0</b>	<b>0</b>	<b>0</b>
9	1.025	1.125	0	1	0	0	1
10	1.050	1.150	0	1	0	1	0
11	1.075	1.175	0	1	0	1	1
12	1.1	1.2	0	1	1	0	0
13	1.125	1.225	0	1	1	0	1
14	1.150	1.25	0	1	1	1	0
15	1.175	1.275	0	1	1	1	1
16	<b>1.2 (default TPS62402, TPS62404)</b>	1.3	1	0	0	0	0
17	1.225	1.325	1	0	0	0	1
18	1.25	1.350	1	0	0	1	0
19	1.275	1.375	1	0	0	1	1
20	1.3	1.4	1	0	1	0	0
21	1.325	1.425	1	0	1	0	1
22	1.350	1.450	1	0	1	1	0
23	1.375	1.475	1	0	1	1	1
24	1.4	1.5	1	1	0	0	0
25	1.425	1.525	1	1	0	0	1
26	1.450	1.55	1	1	0	1	0
27	1.475	1.575	1	1	0	1	1
28	1.5	1.6	1	1	1	0	0
29	1.525	1.7	1	1	1	0	1
30	1.55	<b>1.8 (default TPS62402)</b>	1	1	1	1	0
<b>31</b>	<b>1.575 (default TPS62401, TPS62403)</b>	<b>1.9 (default TPS62404)</b>	<b>1</b>	<b>1</b>	<b>1</b>	<b>1</b>	<b>1</b>

**Table 5. Selectable Output Voltages for Converter 1,  
 With DEF1 Pin as Analog Input (Adjustable, TPS62400)**

	TPS62400 OUTPUT VOLTAGE [V] REGISTER REG_DEF_1_LOW	D4	D3	D2	D1	D0
0	V <sub>OUT1</sub> Adjustable with Resistor Network on DEF_1 Pin (default TPS62400)	0	0	0	0	0
	0.6V with DEF_1 connected to V <sub>OUT1</sub> (default TPS62400)					
1	0.825	0	0	0	0	1
2	0.85	0	0	0	1	0
3	0.875	0	0	0	1	1
4	0.9	0	0	1	0	0
5	0.925	0	0	1	0	1
6	0.95	0	0	1	1	0
7	0.975	0	0	1	1	1
8	1.0	0	1	0	0	0
9	1.025	0	1	0	0	1
10	1.050	0	1	0	1	0
11	1.075	0	1	0	1	1
12	1.1	0	1	1	0	0
13	1.125	0	1	1	0	1
14	1.150	0	1	1	1	0
15	1.175	0	1	1	1	1
16	1.2	1	0	0	0	0
17	1.225	1	0	0	0	1
18	1.25	1	0	0	1	0
19	1.275	1	0	0	1	1
20	1.3	1	0	1	0	0
21	1.325	1	0	1	0	1
22	1.350	1	0	1	1	0
23	1.375	1	0	1	1	1
24	1.4	1	1	0	0	0
25	1.425	1	1	0	0	1
26	1.450	1	1	0	1	0
27	1.475	1	1	0	1	1
28	1.5	1	1	1	0	0
29	1.525	1	1	1	0	1
30	1.55	1	1	1	1	0
31	1.575	1	1	1	1	1

**Table 6. Selectable Output Voltages for Converter 2,  
(ADJ2 Connected to  $V_{OUT}$ )**

	OUTPUT VOLTAGE [V] FOR REGISTER REG_DEF_2	D4	D3	D2	D1	D0
0	$V_{OUT2}$ Adjustable with resistor network and $C_{ff}$ on ADJ2 pin (default TPS62400)	0	0	0	0	0
	0.6V with ADJ2 pin directly connected to $V_{OUT2}$ (default TPS62400)					
1	0.85	0	0	0	0	1
2	0.9	0	0	0	1	0
3	0.95	0	0	0	1	1
4	1.0	0	0	1	0	0
5	1.05	0	0	1	0	1
6	1.1	0	0	1	1	0
7	1.15	0	0	1	1	1
8	1.2	0	1	0	0	0
9	1.25	0	1	0	0	1
10	1.3	0	1	0	1	0
11	1.35	0	1	0	1	1
12	1.4	0	1	1	0	0
13	1.45	0	1	1	0	1
14	1.5	0	1	1	1	0
15	1.55	0	1	1	1	1
16	1.6	1	0	0	0	0
17	1.7	1	0	0	0	1
18	<b>1.8 (default TPS62401)</b>	1	0	0	1	0
19	1.85	1	0	0	1	1
20	2.0	1	0	1	0	0
21	2.1	1	0	1	0	1
22	2.2	1	0	1	1	0
23	2.3	1	0	1	1	1
24	2.4	1	1	0	0	0
25	2.5	1	1	0	0	1
26	2.6	1	1	0	1	0
27	2.7	1	1	0	1	1
28	<b>2.8 (default TPS62403)</b>	1	1	1	0	0
29	2.85	1	1	1	0	1
30	3.0	1	1	1	1	0
31	<b>3.3 (default TPS62402, TPS62404)</b>	1	1	1	1	1

## 9 Application and Implementation

### 9.1 Application Information

The TPS6240x family of devices are synchronous dual step-down DC-DC converters. The devices provide two independent output voltage rails. The following information gives guidance on choosing external components to complete the application design.

### 9.2 Typical Applications

#### 9.2.1 TPS6240x, Dual Outputs Step Down Converter

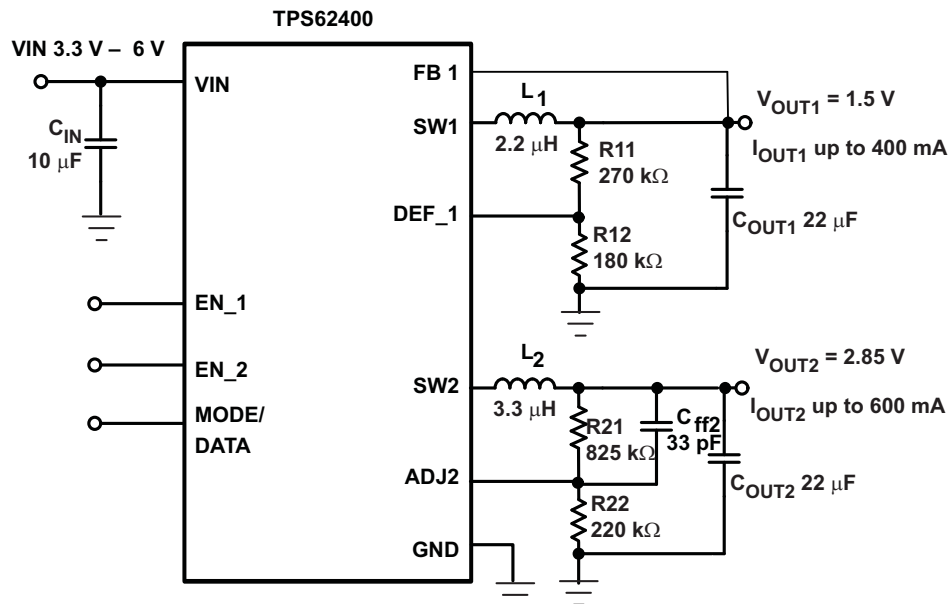

Figure 14. Typical Application Circuit 1.5V/2.85V Adjustable Outputs, Low PFM Voltage Ripple Optimized

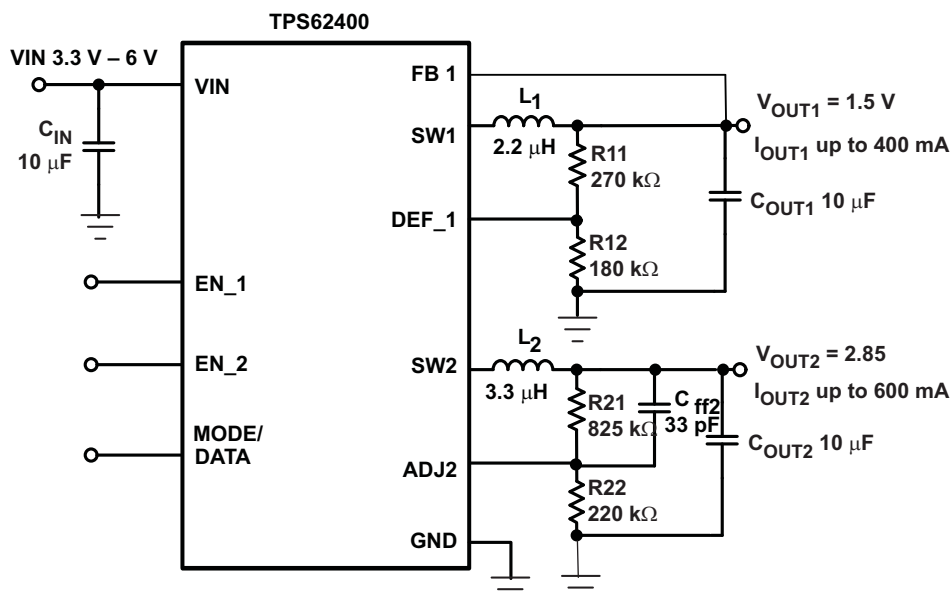

Figure 15. Typical Application Circuit 1.5V/2.85V Adjustable Outputs

## Typical Applications (continued)

### 9.2.1.1 Design Requirements

The step-down converter design can be adapted to different output voltage and load current needs by choosing external components appropriate. The following design procedure is adequate for whole VIN, VOUT and load current range of TPS6240x.

### 9.2.1.2 Detailed Design Procedure

#### 9.2.1.2.1 Converter1 Adjustable Default Output Voltage Setting: TPS62400

The output voltage can be calculated to:

$$V_{OUT} = V_{REF} \times \left( 1 + \frac{R_{11}}{R_{12}} \right) \text{ with an internal reference voltage } V_{REF} \text{ typical } 0.6V \quad (4)$$

To keep the operating current to a minimum, it is recommended to select R12 within a range of 180kΩ to 360kΩ. The sum of R12 and R11 should not exceed ~1MΩ. For higher output voltages than 3.3V, it is recommended to choose lower values than 180kΩ for R12. Route the DEF\_1 line away from noise sources, such as the inductor or the SW1 line. The FB1 line needs to be directly connected to the output capacitor. A feed-forward capacitor is not necessary.

#### 9.2.1.2.2 Converter1 Fixed Default Output Voltage Setting (TPS62401, TPS62402, TPS62403, TPS62404).

The output voltage  $V_{OUT1}$  is selected with DEF\_1 pin.

##### Pin DEF\_1 = low:

TPS62401, TPS62403 = 1.575V

TPS62402, TPS62404 = 1.2V

##### Pin DEF\_1 = high:

TPS62401, TPS62403 = 1.1V

T62402: = 1.8V

T62404: = 1.9V

#### 9.2.1.2.3 Converter 2 Adjustable Default Output Voltage Setting TPS62400:

The output voltage of converter 2 can be set by an external resistor network. For converter 2 the same recommendations apply as for converter1. In addition to that, a 33pF feed-forward Capacitor  $C_{ff2}$  for good load transient response should be used. The output voltage can be calculated to:

$$V_{OUT} = V_{REF} \times \left( 1 + \frac{R_{21}}{R_{22}} \right) \text{ with an internal reference voltage } V_{REF} \text{ typical } 0.6V \quad (5)$$

#### 9.2.1.2.4 Converter 2 Fixed Default Output Voltage Setting

ADJ2 pin must be directly connected with  $V_{OUT2}$

**TPS62401,  $V_{OUT2}$  default = 1.8V**

**TPS62403,  $V_{OUT2}$  default = 2.8V**

**TPS62402, TPS62404,  $V_{OUT2}$  default = 3.3V**

#### 9.2.1.2.5 Output Filter Design (Inductor and Output Capacitor)

The converters are designed to operate with a minimum inductance of 1.75μH and minimum capacitance of 6μF. The device is optimized to operate with inductors of 2.2μH to 4.7μH and output capacitors of 10μF to 22μF.

## Typical Applications (continued)

### 9.2.1.2.5.1 Inductor Selection

The selected inductor has to be rated for its DC resistance and saturation current. The DC resistance of the inductor will influence directly the efficiency of the converter. Therefore an inductor with lowest DC resistance should be selected for highest efficiency.

Equation 6 calculates the maximum inductor current under static load conditions. The saturation current of the inductor should be rated higher than the maximum inductor current as calculated with Equation 7. This is recommended because during heavy load transient the inductor current rises above the calculated value.

$$\Delta I_L = V_{out} \times \frac{1 - \frac{V_{out}}{V_{in}}}{L \times f} \quad (6)$$

$$I_{Lmax} = I_{outmax} + \frac{\Delta I_L}{2} \quad (7)$$

with:

f = Switching Frequency (2.25MHz typical)

L = Inductor Value

$\Delta I_L$  = Peak-to-Peak inductor ripple current

$I_{Lmax}$  = Maximum Inductor current

The highest inductor current occurs at maximum  $V_{in}$ .

Open core inductors have a soft saturation characteristic and they can usually handle higher inductor currents versus a comparable shielded inductor.

A more conservative approach is to select the inductor current rating just for the maximum switch current of the corresponding converter. Take into consideration that the core material from inductor to inductor differs and this difference has an impact on the efficiency.

Refer to Table 7 and the typical application circuit examples for possible inductors.

**Table 7. List of Inductors**

DIMENSIONS [mm <sup>3</sup> ]	INDUCTOR TYPE	SUPPLIER
3.2x2.6x1.0	MIPW3226	FDK
3x3x0.9	LPS3010	Coilcraft
2.8x2.6x1.0	VLF3010	TDK
2.8x2.6x1.4	VLF3014	TDK
3x3x1.4	LPS3015	Coilcraft
3.9x3.9x1.7	LPS4018	Coilcraft

### 9.2.1.2.5.2 Output Capacitor Selection

The advanced fast response voltage mode control scheme of the converters allows the use of tiny ceramic capacitors with a typical value of 10 $\mu$ F to 22 $\mu$ F, without having large output voltage under and overshoots during heavy load transients. Ceramic capacitors with low ESR values results in lowest output voltage ripple, and are therefore recommended. The output capacitor requires either X7R or X5R dielectric. Y5V and Z5U dielectric capacitors are not recommended due to their wide variation in capacitance.

If ceramic output capacitors are used, the capacitor RMS ripple current rating always meets the application requirements. The RMS ripple current is calculated as:

$$I_{RMSout} = V_{out} \times \frac{1 - \frac{V_{out}}{V_{in}}}{L \times f} \times \frac{1}{2 \times \sqrt{3}} \quad (8)$$

At nominal load current the inductive converters operate in PWM mode and the overall output voltage ripple is the sum of the voltage spike caused by the output capacitor ESR, plus the voltage ripple caused by charging and discharging the output capacitor:

$$\Delta V_{out} = V_{out} \times \frac{1 - \frac{V_{out}}{V_{in}}}{L \times f} \times \left( \frac{1}{8 \times C_{out} \times f} + ESR \right) \quad (9)$$

Where the highest output voltage ripple occurs at the highest input voltage  $V_{in}$ .

At light load currents the converters operate in Power Save Mode and the output voltage ripple is dependent on the output capacitor value. The output voltage ripple is set by the internal comparator delay and the external capacitor. Higher output capacitors like 22 $\mu$ F values minimize the voltage ripple in PFM Mode and tighten DC output accuracy in PFM Mode.

### 9.2.1.2.5.3 Input Capacitor Selection

Because of the nature of the buck converter having a pulsating input current, a low ESR input capacitor is required to prevent large voltage transients that can cause misbehavior of the device or interference with other circuits in the system. An input capacitor of 10 $\mu$ F is sufficient.

### 9.2.1.3 Application Curves

$V_{IN} = 3.6$  V, and  $T_A = 25$  °C, unless otherwise noted.

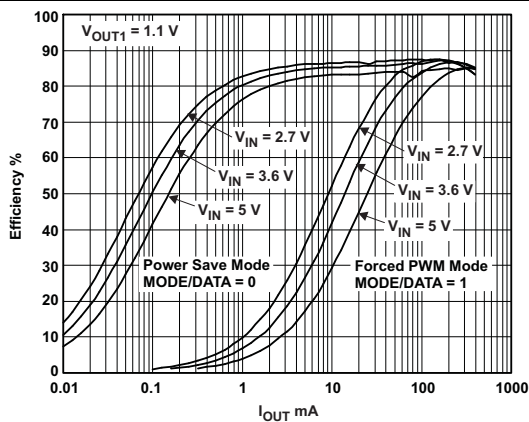

Figure 16. Efficiency TPS62401 VOUT1 = 1.1V

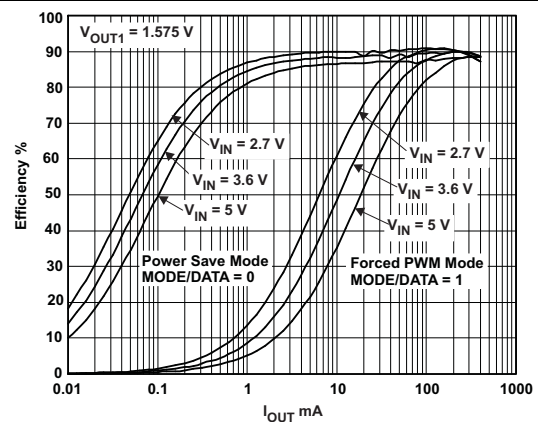

Figure 17. Efficiency TPS62401 VOUT1 = 1.575V

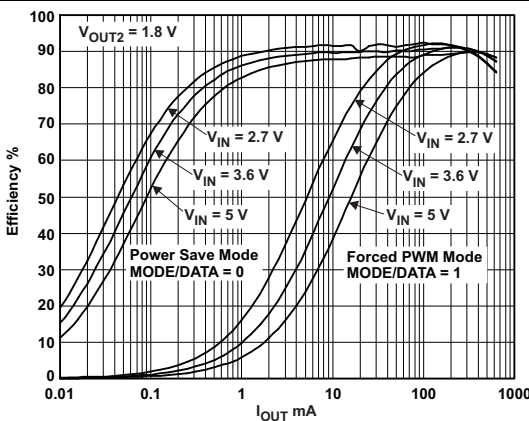

Figure 18. Efficiency VOUT 2 = 1.8V

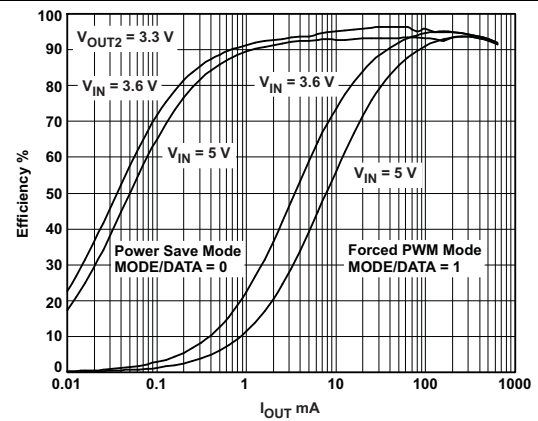

Figure 19. Efficiency TPS62400 VOUT 2 = 3.3V

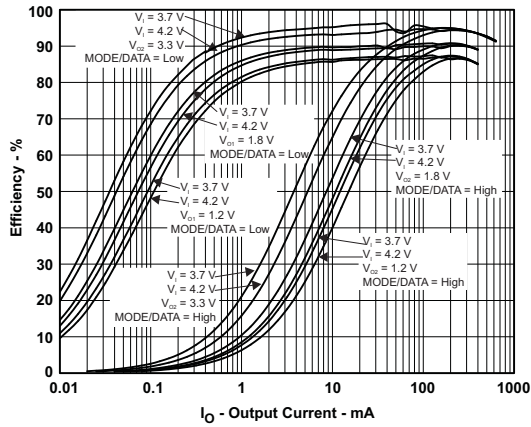

Figure 20. Efficiency TPS62402 VOUT1/VOUT2

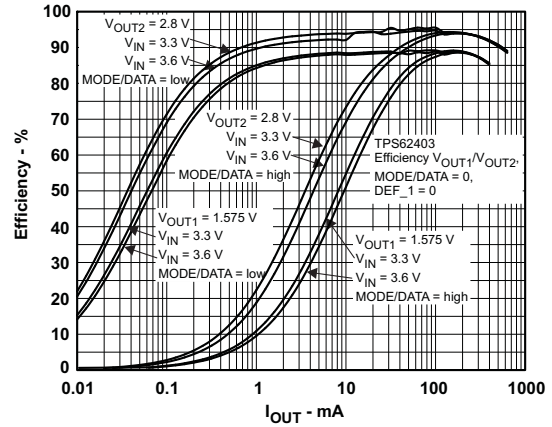

Figure 21. Efficiency TPS62403 VOUT1/VOUT2

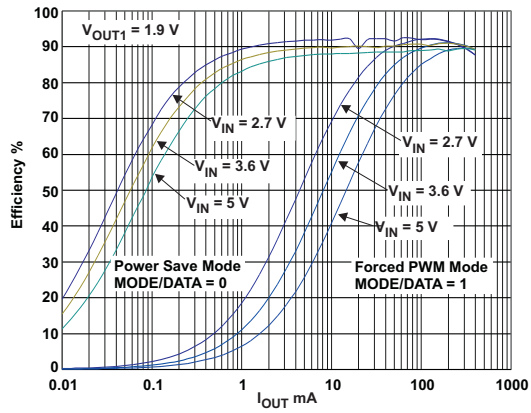

Figure 22. Efficiency TPS62404 VOUT1 = 1.9V, DEF\_1 = HIGH

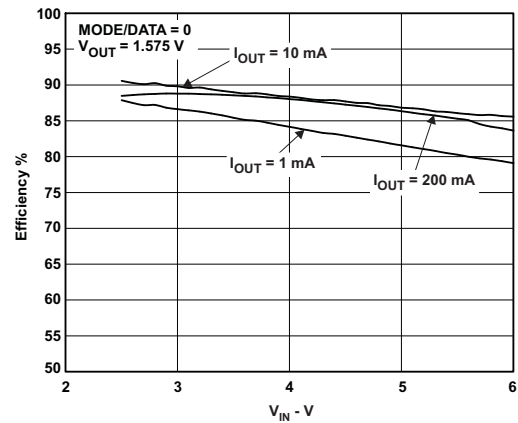

Figure 23. Efficiency vs  $V_{IN}$

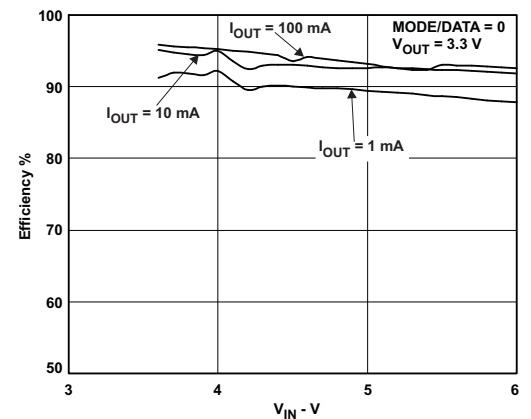

Figure 24. EFFICIENCY vs  $V_{IN}$

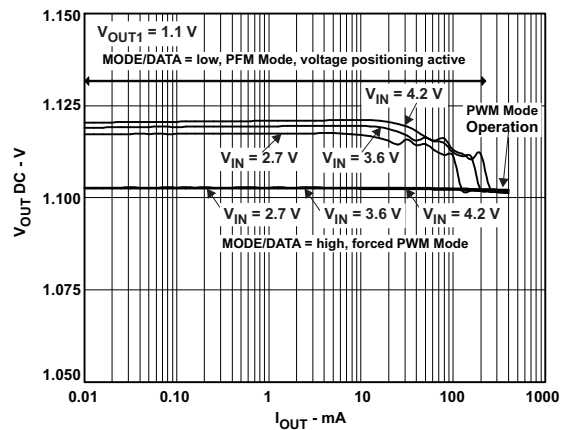

Figure 25. DC Output Accuracy VOUT1 = 1.1V

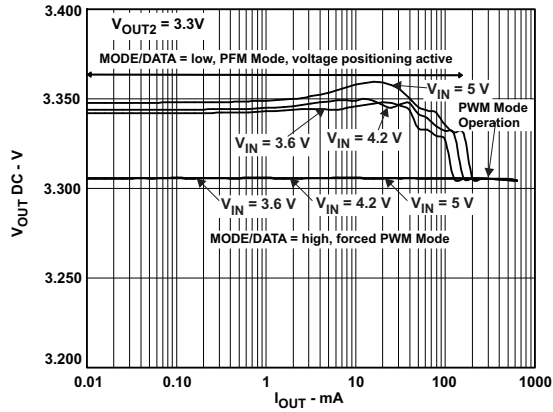

Figure 26. DC Output Accuracy  $V_{OUT2} = 3.3V$

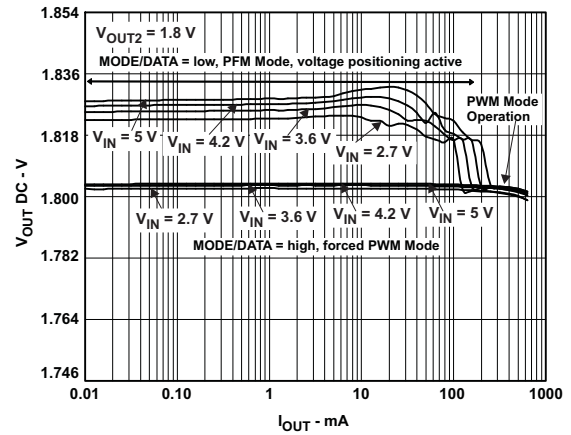

Figure 27. DC Output Accuracy  $V_{OUT2} = 1.8V$

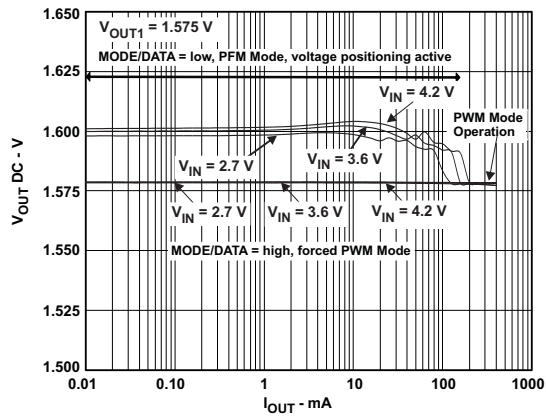

Figure 28. DC Output Accuracy  $V_{OUT1} = 1.575V$ ,  
 $L = 2.2\mu H$ ,  $C_{OUT} = 22\mu F$

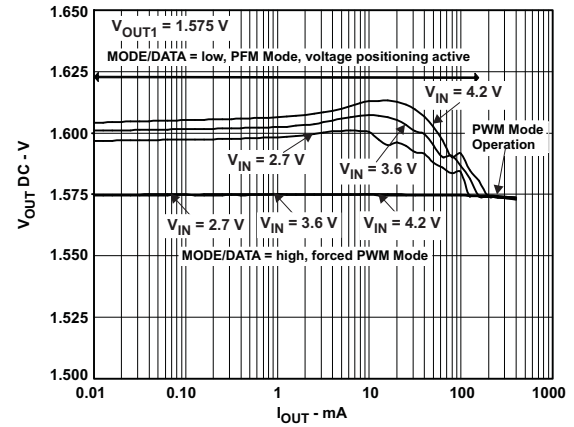

Figure 29. DC Output Accuracy  $V_{OUT1} = 1.575V$ ,  
 $L = 3.3\mu H$ ,  $C_{OUT} = 10\mu F$

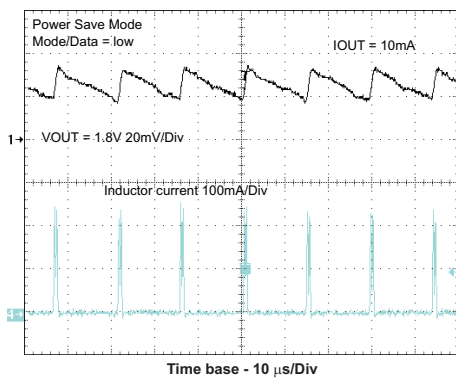

Figure 30. Light Load Output Voltage Ripple In Power Save Mode

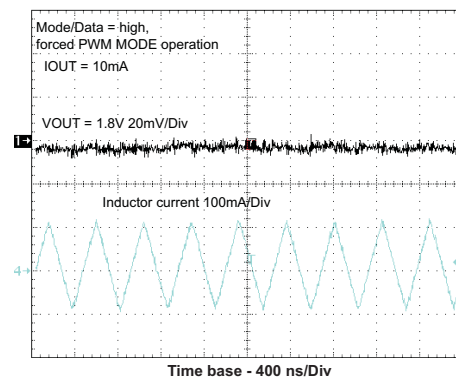

Figure 31. Output Voltage Ripple In Forced PWM Mode

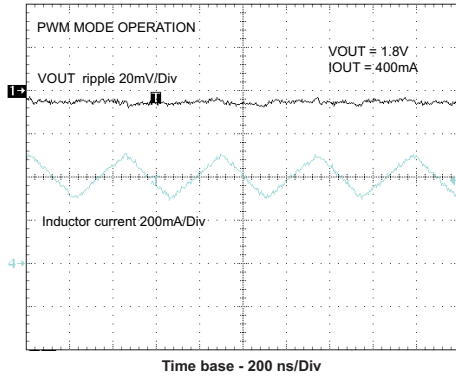

Figure 32. Output Voltage Ripple In PWM Mode

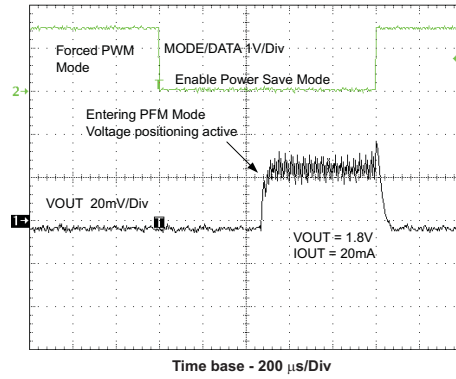

Figure 33. Forced PWM/PFM Mode Transition

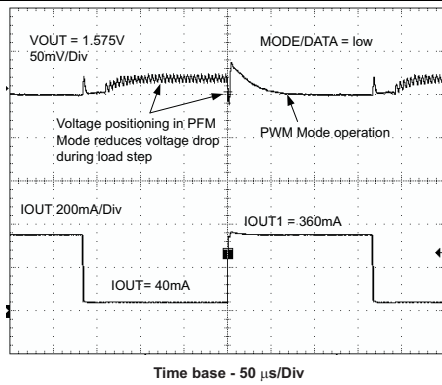

Figure 34. Load Transient Response PFM/PWM

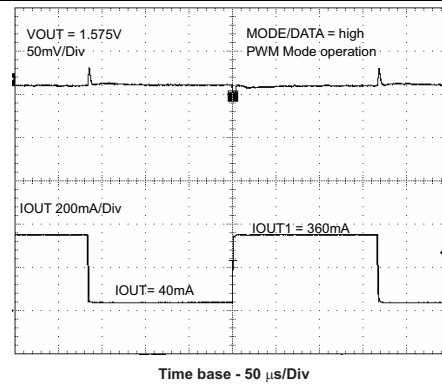

Figure 35. Load Transient Response PWM Operation

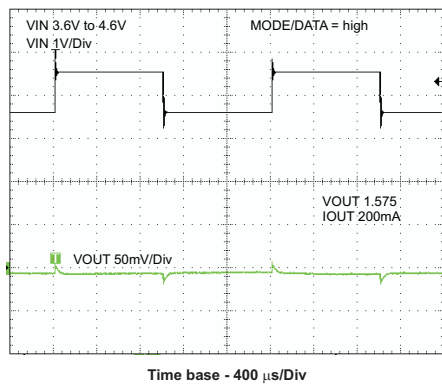

Figure 36. Line Transient Response

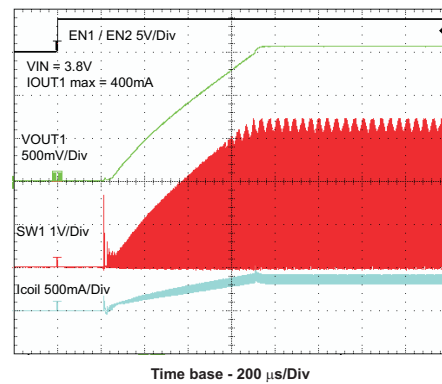

Figure 37. Startup Timing One Converter

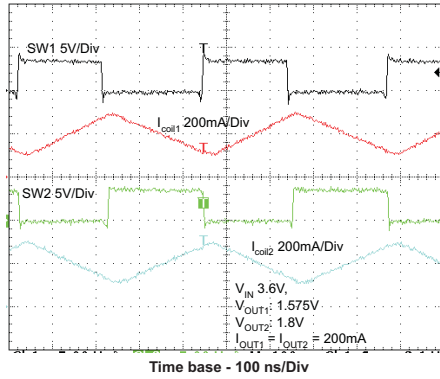

Figure 38. Typical Operation  $V_{IN} = 3.6V$ ,  
 $V_{OUT1} = 1.575V$ ,  $V_{OUT2} = 1.8V$

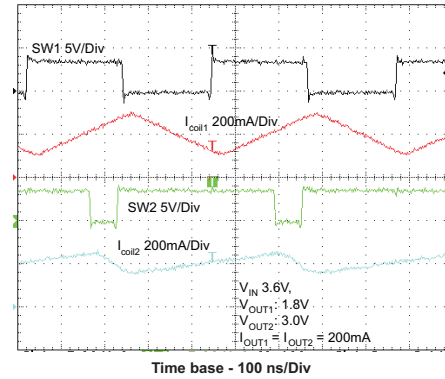

Figure 39. Typical Operation  $V_{IN} = 3.6V$ ,  
 $V_{OUT1} = 1.8V$ ,  $V_{OUT2} = 3.0V$

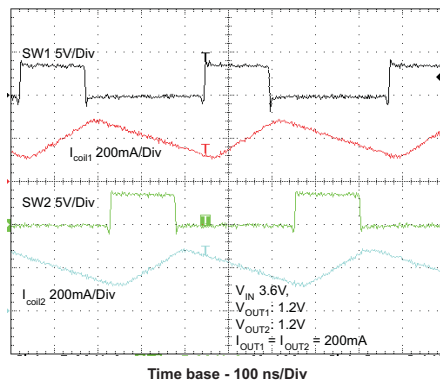

Figure 40. Typical Operation  $V_{IN} = 3.6V$ ,  
 $V_{OUT1} = 1.2V$ ,  $V_{OUT2} = 1.2V$

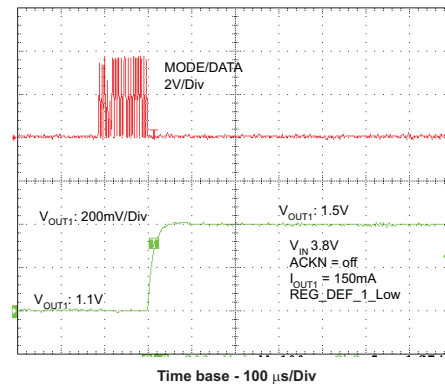

Figure 41.  $V_{OUT1}$  Change With Easyscale

## 9.2.2 Various Output Voltages

The TPS6240x is able to be set for different output voltages. Some examples are shown below.

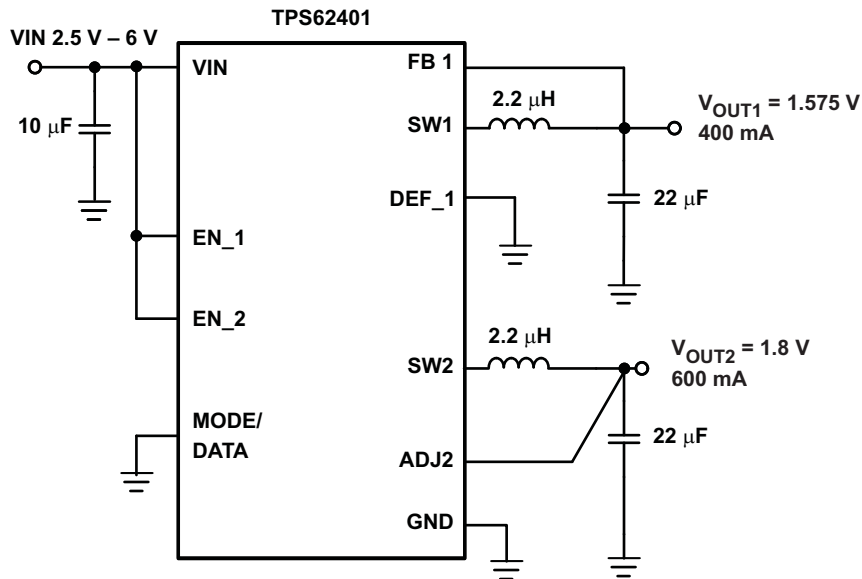

Figure 42. TPS62401 Fixed 1.575V/1.8V Outputs, Low PFM Voltage Ripple Optimized

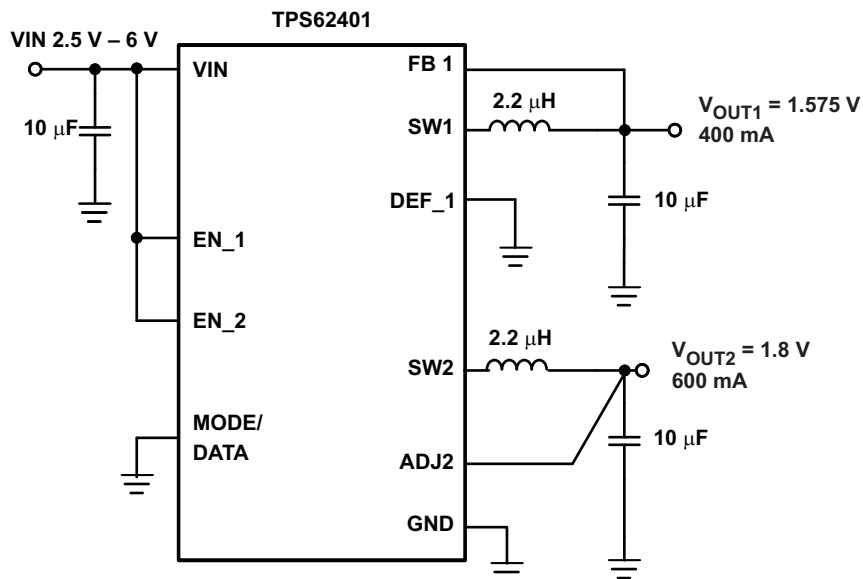

Figure 43. TPS62401 Fixed 1.575V/1.8V Outputs

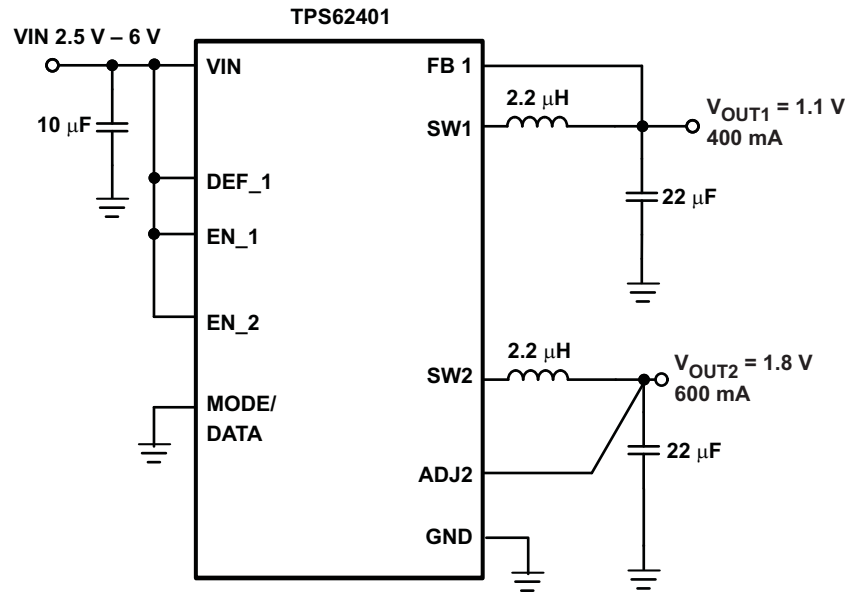

Figure 44. TPS62401 Fixed 1.1V/1.8V Outputs, Low PFM Ripple Voltage Optimized

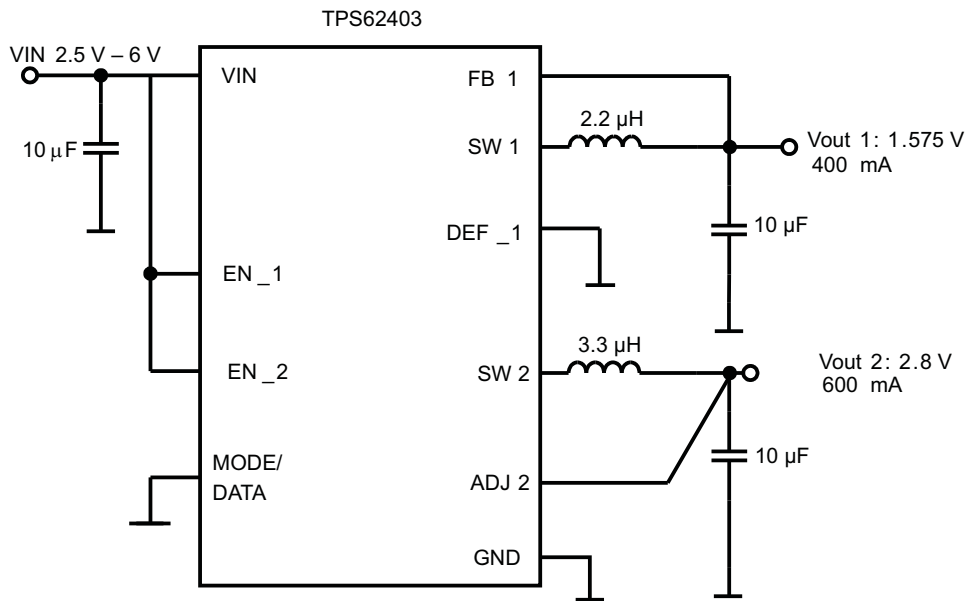

Figure 45. TPS62403 1.575V/2.8V Outputs

### 9.2.2.1 Design Requirements

The TPS6240x step-down converter is set to different output voltages.

### 9.2.2.2 Detailed Design Procedure

See [TPS6240x, Dual Outputs Step Down Converter](#).

### 9.2.3 Dynamic Voltage Scaling on Converter 1 by DEF\_1 Pin

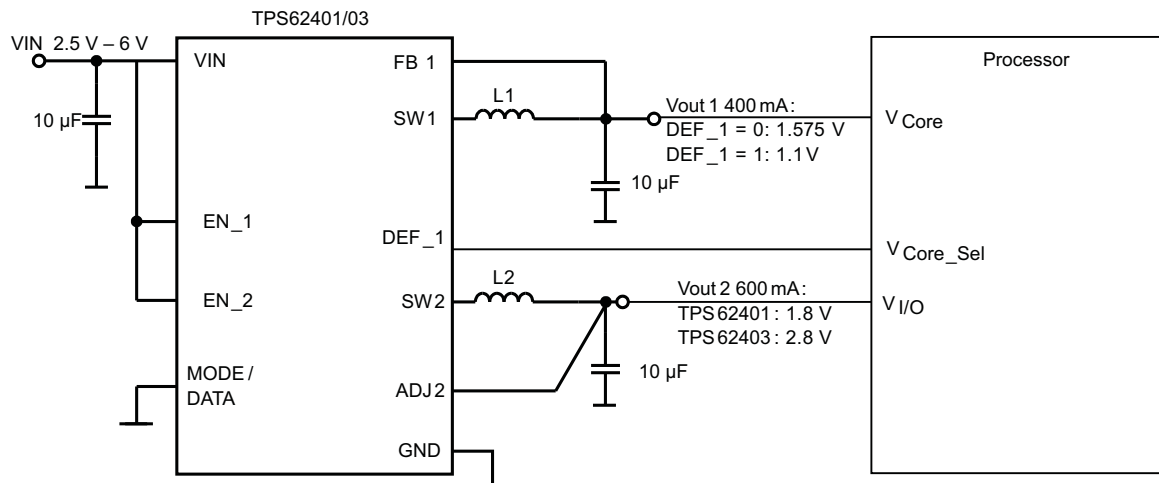

Figure 46. Dynamic Voltage Scaling on Converter 1 by DEF\_1 Pin

#### 9.2.3.1 Design Requirements

Control the output voltage of the converter 1 through DEF\_1 pin by an external processor.

#### 9.2.3.2 Detailed Design Procedure

Connect the DEF\_1 pin to the  $V_{Core\_Sel}$  pin of an external processor, as shown in Figure 46. The processor determines the logic status of the DEF\_1 pin which sets the output voltage of the converter 1.

### 9.2.4 Application Curves

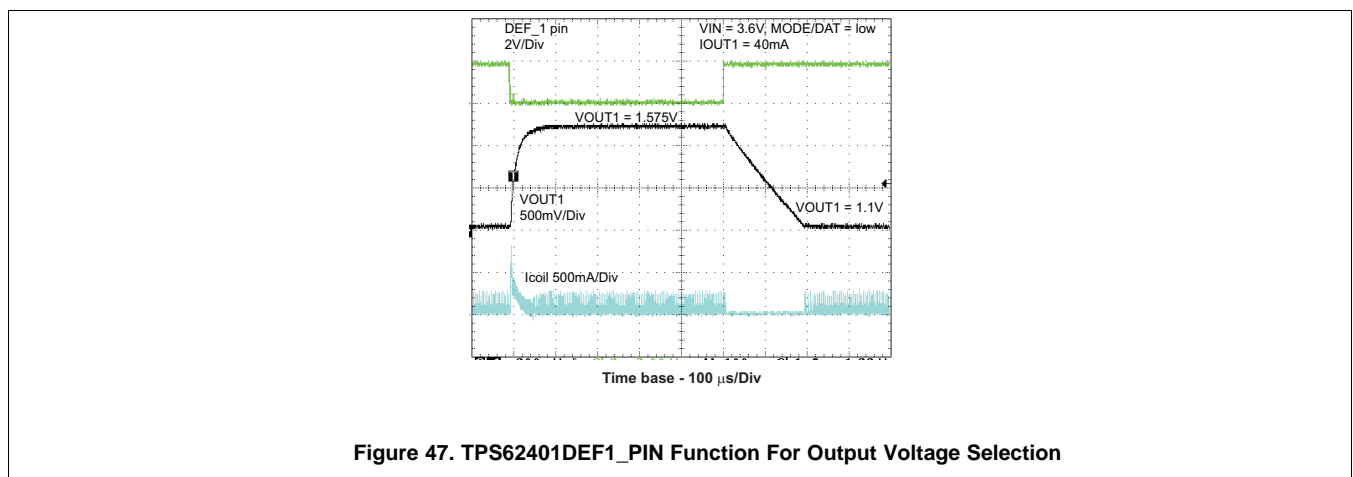

Figure 47. TPS62401DEF1\_PIN Function For Output Voltage Selection

## 10 Power Supply Recommendations

The TPS6240x device family has no special requirements for its input power supply. The input power supply's output current needs to be rated according to the supply voltage, output voltage and output current of the TPS6240x.

## 11 Layout

### 11.1 Layout Guidelines

As for all switching power supplies, the layout is an important step in the design. Proper function of the device demands careful attention to PCB layout. Care must be taken in board layout to get the specified performance. If the layout is not carefully done, the regulator could show poor line and/or load regulation, stability issues as well as EMI problems. It is critical to provide a low-inductance, impedance ground path. Therefore, use wide and short traces for the main current paths as indicated in bold in [Figure 48](#).

The input capacitor should be placed as close as possible to the IC pins VIN and GND, the inductor and output capacitor as close as possible to the pins SW1 and GND.

Connect the GND Pin of the device to the PowerPAD of the PCB and use this Pad as a star point. For each converter use a common Power GND node and a different node for the signal GND to minimize the effects of ground noise. Connect these ground nodes together to the PowerPAD (star point) underneath the IC. Keep the common path to the GND PIN, which returns the small signal components and the high current of the output capacitors, as short as possible to avoid ground noise. The output voltage sense lines (FB 1, DEF\_1, ADJ2) should be connected right to the output capacitor and routed away from noisy components and traces (e.g., SW1 and SW2 lines). If the EasyScale™ interface is operated with high transmission rates, the MODE/DATA trace must be routed away from the ADJ2 line to avoid capacitive coupling into the ADJ2 pin. A GND guard ring between the MODE/DATA pin and ADJ2 pin avoids potential noise coupling.

### 11.2 Layout Example

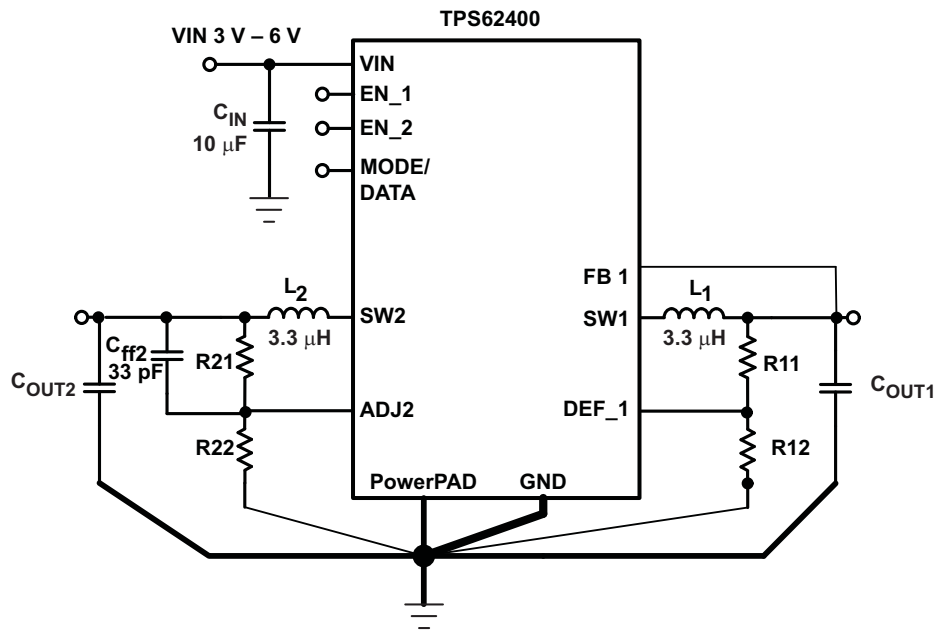

Figure 48. Layout Diagram

Layout Example (continued)

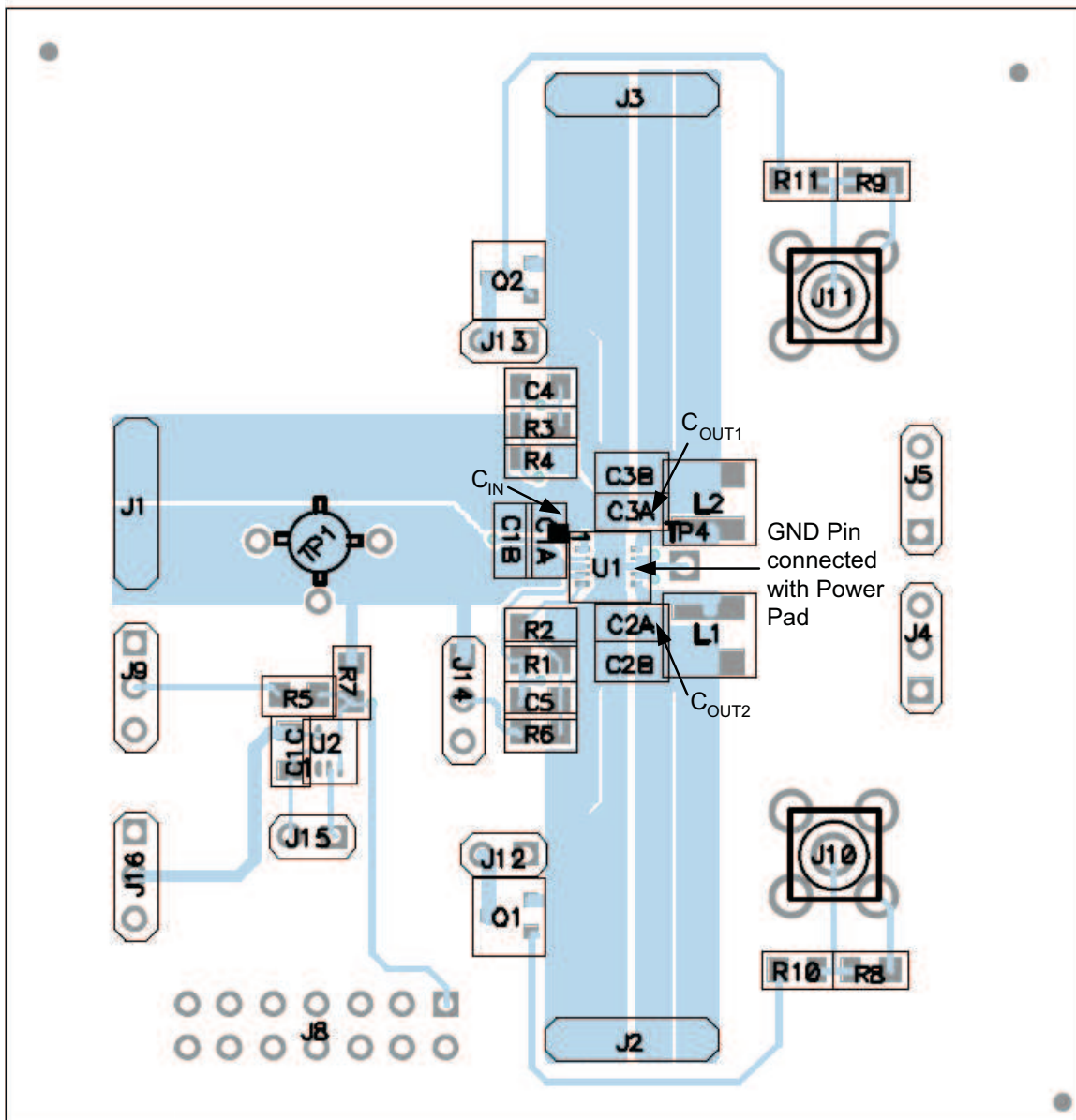

Figure 49. PCB Layout

## 12 Device and Documentation Support

### 12.1 Device Support

#### 12.1.1 Third-Party Products Disclaimer

TI'S PUBLICATION OF INFORMATION REGARDING THIRD-PARTY PRODUCTS OR SERVICES DOES NOT CONSTITUTE AN ENDORSEMENT REGARDING THE SUITABILITY OF SUCH PRODUCTS OR SERVICES OR A WARRANTY, REPRESENTATION OR ENDORSEMENT OF SUCH PRODUCTS OR SERVICES, EITHER ALONE OR IN COMBINATION WITH ANY TI PRODUCT OR SERVICE.

### 12.2 Related Links

The table below lists quick access links. Categories include technical documents, support and community resources, tools and software, and quick access to sample or buy.

**Table 8. Related Links**

PARTS	PRODUCT FOLDER	SAMPLE & BUY	TECHNICAL DOCUMENTS	TOOLS & SOFTWARE	SUPPORT & COMMUNITY
TPS62400	<a href="#">Click here</a>	<a href="#">Click here</a>	<a href="#">Click here</a>	<a href="#">Click here</a>	<a href="#">Click here</a>
TPS62401	<a href="#">Click here</a>	<a href="#">Click here</a>	<a href="#">Click here</a>	<a href="#">Click here</a>	<a href="#">Click here</a>
TPS62402	<a href="#">Click here</a>	<a href="#">Click here</a>	<a href="#">Click here</a>	<a href="#">Click here</a>	<a href="#">Click here</a>
TPS62403	<a href="#">Click here</a>	<a href="#">Click here</a>	<a href="#">Click here</a>	<a href="#">Click here</a>	<a href="#">Click here</a>
TPS62404	<a href="#">Click here</a>	<a href="#">Click here</a>	<a href="#">Click here</a>	<a href="#">Click here</a>	<a href="#">Click here</a>

### 12.3 Trademarks

EasyScale, OMAP, PowerPAD are trademarks of Texas Instruments. All other trademarks are the property of their respective owners.

### 12.4 Electrostatic Discharge Caution



These devices have limited built-in ESD protection. The leads should be shorted together or the device placed in conductive foam during storage or handling to prevent electrostatic damage to the MOS gates.

### 12.5 Glossary

[SLYZ022](#) — *TI Glossary*.

This glossary lists and explains terms, acronyms, and definitions.

## 13 Mechanical, Packaging, and Orderable Information

The following pages include mechanical, packaging, and orderable information. This information is the most current data available for the designated devices. This data is subject to change without notice and revision of this document. For browser-based versions of this data sheet, refer to the left-hand navigation.

**PACKAGING INFORMATION**

Orderable Device	Status (1)	Package Type	Package Drawing	Pins	Package Qty	Eco Plan (2)	Lead finish/ Ball material (6)	MSL Peak Temp (3)	Op Temp (°C)	Device Marking (4/5)	Samples
TPS62400DRCR	ACTIVE	VSON	DRC	10	3000	RoHS & Green	NIPDAU	Level-2-260C-1 YEAR	-40 to 85	BQE	<a href="#">Samples</a>
TPS62400DRCRG4	ACTIVE	VSON	DRC	10	3000	RoHS & Green	NIPDAU	Level-2-260C-1 YEAR	-40 to 85	BQE	<a href="#">Samples</a>
TPS62400DRCT	ACTIVE	VSON	DRC	10	250	RoHS & Green	NIPDAU	Level-2-260C-1 YEAR	-40 to 85	BQE	<a href="#">Samples</a>
TPS62400DRCTG4	ACTIVE	VSON	DRC	10	250	RoHS & Green	NIPDAU	Level-2-260C-1 YEAR	-40 to 85	BQE	<a href="#">Samples</a>
TPS62401DRCR	ACTIVE	VSON	DRC	10	3000	RoHS & Green	NIPDAU	Level-2-260C-1 YEAR	-40 to 85	BRN	<a href="#">Samples</a>
TPS62401DRCT	ACTIVE	VSON	DRC	10	250	RoHS & Green	NIPDAU	Level-2-260C-1 YEAR	-40 to 85	BRN	<a href="#">Samples</a>
TPS62402DRCR	ACTIVE	VSON	DRC	10	3000	RoHS & Green	NIPDAU	Level-2-260C-1 YEAR	-40 to 85	BYH	<a href="#">Samples</a>
TPS62402DRCRG4	ACTIVE	VSON	DRC	10	3000	RoHS & Green	NIPDAU	Level-2-260C-1 YEAR	-40 to 85	BYH	<a href="#">Samples</a>
TPS62402DRCT	ACTIVE	VSON	DRC	10	250	RoHS & Green	NIPDAU	Level-2-260C-1 YEAR	-40 to 85	BYH	<a href="#">Samples</a>
TPS62402DRCTG4	ACTIVE	VSON	DRC	10	250	RoHS & Green	NIPDAU	Level-2-260C-1 YEAR	-40 to 85	BYH	<a href="#">Samples</a>
TPS62403DRCT	ACTIVE	VSON	DRC	10	250	RoHS & Green	NIPDAU	Level-2-260C-1 YEAR	-40 to 85	BYI 65024	<a href="#">Samples</a>
TPS62404DRCR	ACTIVE	VSON	DRC	10	3000	RoHS & Green	NIPDAU	Level-2-260C-1 YEAR	-40 to 85	PTVI	<a href="#">Samples</a>
TPS62404DRCT	ACTIVE	VSON	DRC	10	250	RoHS & Green	NIPDAU	Level-2-260C-1 YEAR	-40 to 85	PTVI	<a href="#">Samples</a>

(1) The marketing status values are defined as follows:

**ACTIVE:** Product device recommended for new designs.

**LIFEBUY:** TI has announced that the device will be discontinued, and a lifetime-buy period is in effect.

**NRND:** Not recommended for new designs. Device is in production to support existing customers, but TI does not recommend using this part in a new design.

**PREVIEW:** Device has been announced but is not in production. Samples may or may not be available.

**OBSOLETE:** TI has discontinued the production of the device.

(2) **RoHS:** TI defines "RoHS" to mean semiconductor products that are compliant with the current EU RoHS requirements for all 10 RoHS substances, including the requirement that RoHS substance do not exceed 0.1% by weight in homogeneous materials. Where designed to be soldered at high temperatures, "RoHS" products are suitable for use in specified lead-free processes. TI may reference these types of products as "Pb-Free".

**RoHS Exempt:** TI defines "RoHS Exempt" to mean products that contain lead but are compliant with EU RoHS pursuant to a specific EU RoHS exemption.

---

**Green:** TI defines "Green" to mean the content of Chlorine (Cl) and Bromine (Br) based flame retardants meet JS709B low halogen requirements of  $\leq 1000$ ppm threshold. Antimony trioxide based flame retardants must also meet the  $\leq 1000$ ppm threshold requirement.

(3) MSL, Peak Temp. - The Moisture Sensitivity Level rating according to the JEDEC industry standard classifications, and peak solder temperature.

(4) There may be additional marking, which relates to the logo, the lot trace code information, or the environmental category on the device.

(5) Multiple Device Markings will be inside parentheses. Only one Device Marking contained in parentheses and separated by a "~" will appear on a device. If a line is indented then it is a continuation of the previous line and the two combined represent the entire Device Marking for that device.

(6) Lead finish/Ball material - Orderable Devices may have multiple material finish options. Finish options are separated by a vertical ruled line. Lead finish/Ball material values may wrap to two lines if the finish value exceeds the maximum column width.

**Important Information and Disclaimer:** The information provided on this page represents TI's knowledge and belief as of the date that it is provided. TI bases its knowledge and belief on information provided by third parties, and makes no representation or warranty as to the accuracy of such information. Efforts are underway to better integrate information from third parties. TI has taken and continues to take reasonable steps to provide representative and accurate information but may not have conducted destructive testing or chemical analysis on incoming materials and chemicals. TI and TI suppliers consider certain information to be proprietary, and thus CAS numbers and other limited information may not be available for release.

In no event shall TI's liability arising out of such information exceed the total purchase price of the TI part(s) at issue in this document sold by TI to Customer on an annual basis.

**OTHER QUALIFIED VERSIONS OF TPS62400, TPS62402, TPS62404 :**

- Automotive: [TPS62400-Q1](#), [TPS62402-Q1](#), [TPS62404-Q1](#)

NOTE: Qualified Version Definitions:

- Automotive - Q100 devices qualified for high-reliability automotive applications targeting zero defects

**TAPE AND REEL INFORMATION**

**QUADRANT ASSIGNMENTS FOR PIN 1 ORIENTATION IN TAPE**

\*All dimensions are nominal

Device	Package Type	Package Drawing	Pins	SPQ	Reel Diameter (mm)	Reel Width W1 (mm)	A0 (mm)	B0 (mm)	K0 (mm)	P1 (mm)	W (mm)	Pin1 Quadrant
TPS62400DRCR	VSON	DRC	10	3000	330.0	12.4	3.3	3.3	1.1	8.0	12.0	Q2
TPS62400DRCT	VSON	DRC	10	250	180.0	12.4	3.3	3.3	1.1	8.0	12.0	Q2
TPS62401DRCR	VSON	DRC	10	3000	330.0	12.4	3.3	3.3	1.1	8.0	12.0	Q2
TPS62401DRCT	VSON	DRC	10	250	180.0	12.4	3.3	3.3	1.1	8.0	12.0	Q2
TPS62402DRCR	VSON	DRC	10	3000	330.0	12.4	3.3	3.3	1.1	8.0	12.0	Q2
TPS62402DRCT	VSON	DRC	10	250	180.0	12.4	3.3	3.3	1.1	8.0	12.0	Q2
TPS62403DRCT	VSON	DRC	10	250	180.0	12.4	3.3	3.3	1.1	8.0	12.0	Q2
TPS62404DRCR	VSON	DRC	10	3000	330.0	12.4	3.3	3.3	1.1	8.0	12.0	Q2
TPS62404DRCT	VSON	DRC	10	250	180.0	12.4	3.3	3.3	1.1	8.0	12.0	Q2

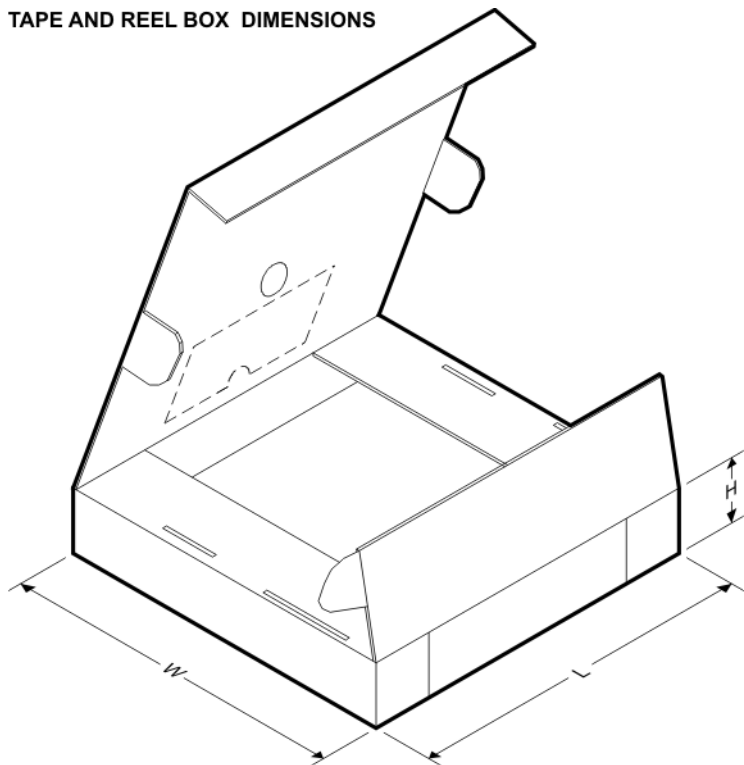
**TAPE AND REEL BOX DIMENSIONS**

\*All dimensions are nominal

Device	Package Type	Package Drawing	Pins	SPQ	Length (mm)	Width (mm)	Height (mm)
TPS62400DRCR	VSON	DRC	10	3000	367.0	367.0	35.0
TPS62400DRCT	VSON	DRC	10	250	210.0	185.0	35.0
TPS62401DRCR	VSON	DRC	10	3000	367.0	367.0	35.0
TPS62401DRCT	VSON	DRC	10	250	210.0	185.0	35.0
TPS62402DRCR	VSON	DRC	10	3000	367.0	367.0	35.0
TPS62402DRCT	VSON	DRC	10	250	210.0	185.0	35.0
TPS62403DRCT	VSON	DRC	10	250	210.0	185.0	35.0
TPS62404DRCR	VSON	DRC	10	3000	853.0	449.0	35.0
TPS62404DRCT	VSON	DRC	10	250	210.0	185.0	35.0

## GENERIC PACKAGE VIEW

**DRC 10**

**VSON - 1 mm max height**

3 x 3, 0.5 mm pitch

PLASTIC SMALL OUTLINE - NO LEAD

This image is a representation of the package family, actual package may vary.  
Refer to the product data sheet for package details.

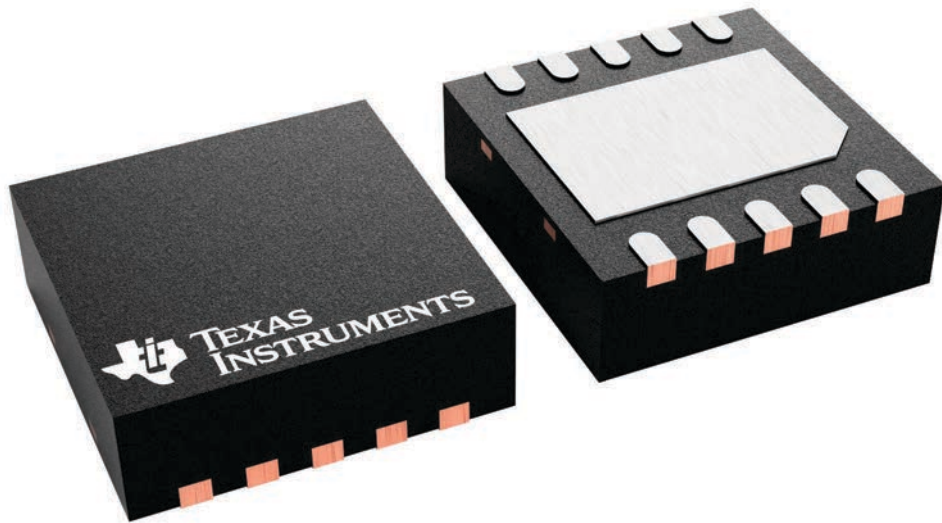

4226193/A



# EXAMPLE BOARD LAYOUT

DRC0010J

VSON - 1 mm max height

PLASTIC SMALL OUTLINE - NO LEAD

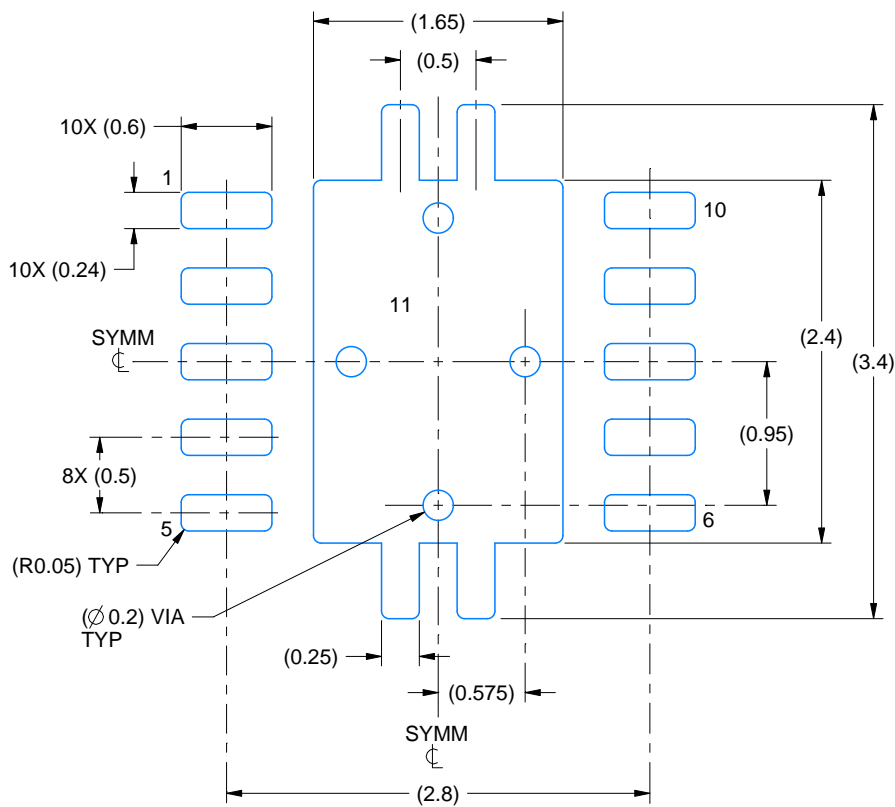

LAND PATTERN EXAMPLE  
EXPOSED METAL SHOWN  
SCALE:20X

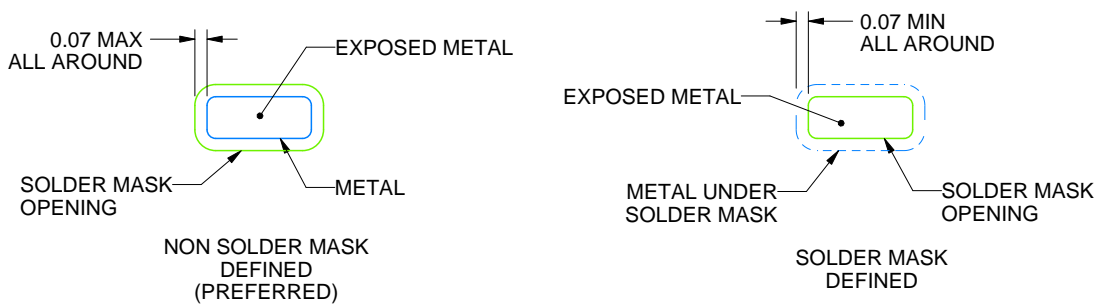

SOLDER MASK DETAILS

4218878/B 07/2018

NOTES: (continued)

4. This package is designed to be soldered to a thermal pad on the board. For more information, see Texas Instruments literature number SLUA271 ([www.ti.com/lit/sluea271](http://www.ti.com/lit/sluea271)).
5. Vias are optional depending on application, refer to device data sheet. If any vias are implemented, refer to their locations shown on this view. It is recommended that vias under paste be filled, plugged or tented.

# EXAMPLE STENCIL DESIGN

DRC0010J

VSON - 1 mm max height

PLASTIC SMALL OUTLINE - NO LEAD

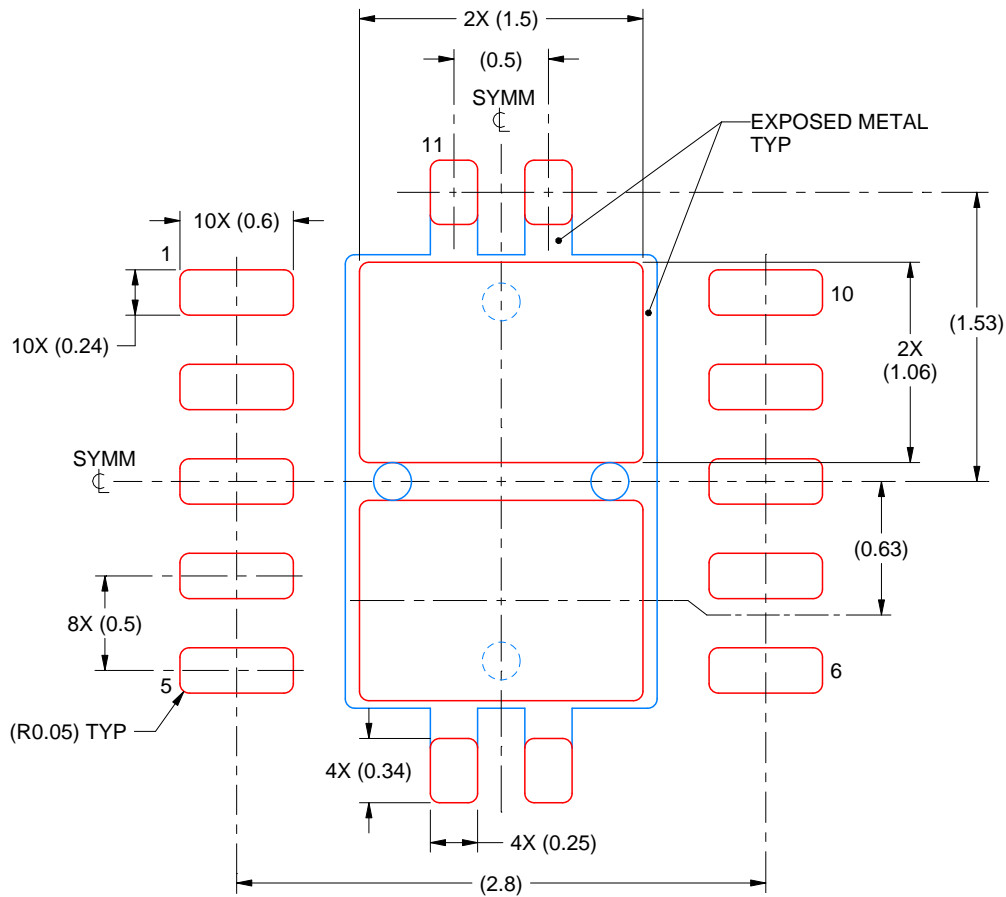

SOLDER PASTE EXAMPLE  
BASED ON 0.125 mm THICK STENCIL

EXPOSED PAD 11:  
80% PRINTED SOLDER COVERAGE BY AREA  
SCALE:25X

4218878/B 07/2018

NOTES: (continued)

6. Laser cutting apertures with trapezoidal walls and rounded corners may offer better paste release. IPC-7525 may have alternate design recommendations.

## IMPORTANT NOTICE AND DISCLAIMER

TI PROVIDES TECHNICAL AND RELIABILITY DATA (INCLUDING DATA SHEETS), DESIGN RESOURCES (INCLUDING REFERENCE DESIGNS), APPLICATION OR OTHER DESIGN ADVICE, WEB TOOLS, SAFETY INFORMATION, AND OTHER RESOURCES "AS IS" AND WITH ALL FAULTS, AND DISCLAIMS ALL WARRANTIES, EXPRESS AND IMPLIED, INCLUDING WITHOUT LIMITATION ANY IMPLIED WARRANTIES OF MERCHANTABILITY, FITNESS FOR A PARTICULAR PURPOSE OR NON-INFRINGEMENT OF THIRD PARTY INTELLECTUAL PROPERTY RIGHTS.

These resources are intended for skilled developers designing with TI products. You are solely responsible for (1) selecting the appropriate TI products for your application, (2) designing, validating and testing your application, and (3) ensuring your application meets applicable standards, and any other safety, security, regulatory or other requirements.

These resources are subject to change without notice. TI grants you permission to use these resources only for development of an application that uses the TI products described in the resource. Other reproduction and display of these resources is prohibited. No license is granted to any other TI intellectual property right or to any third party intellectual property right. TI disclaims responsibility for, and you will fully indemnify TI and its representatives against, any claims, damages, costs, losses, and liabilities arising out of your use of these resources.

TI's products are provided subject to [TI's Terms of Sale](#) or other applicable terms available either on [ti.com](http://ti.com) or provided in conjunction with such TI products. TI's provision of these resources does not expand or otherwise alter TI's applicable warranties or warranty disclaimers for TI products.

TI objects to and rejects any additional or different terms you may have proposed.

Mailing Address: Texas Instruments, Post Office Box 655303, Dallas, Texas 75265  
Copyright © 2022, Texas Instruments Incorporated