

## FAST-TRANSIENT RESPONSE 5-A LOW-DROPOUT VOLTAGE REGULATORS

### FEATURES

- 5-A Low-Dropout Voltage Regulator
- Available in 1.5-V, 1.8-V, 2.5-V, and 3.3-V Fixed-Output and Adjustable Versions
- Dropout Voltage Typically 250 mV at 5 A (TPS75633)
- Low 125  $\mu$ A Typical Quiescent Current
- Fast Transient Response
- 3% Tolerance Over Specified Conditions for Fixed-Output Versions
- Available in 5-Pin TO-220 and TO-263 Surface-Mount Packages
- Thermal Shutdown Protection

### DESCRIPTION

The TPS756xx family of 5-A low dropout (LDO) regulators contains four fixed voltage option regulators and an adjustable voltage option regulator. These devices are capable of supplying 5 A of output current with a dropout of 250 mV (TPS75633). Therefore, the device is capable of performing a 3.3-V to 2.5-V conversion.

Quiescent current is 125  $\mu$ A at full load and drops down to less than 1  $\mu$ A when the device is disabled. The TPS756xx is designed to have fast transient response for large load current changes.

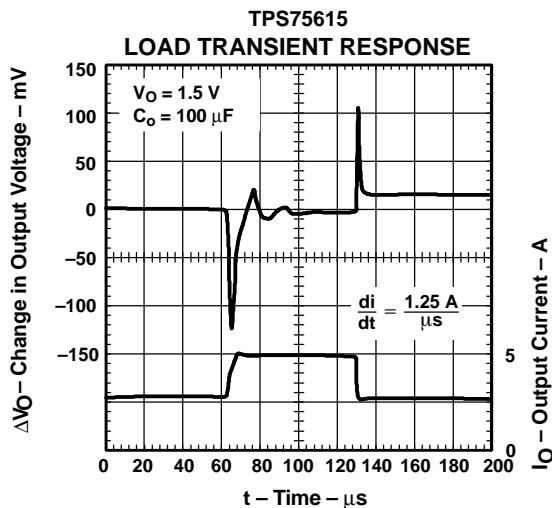
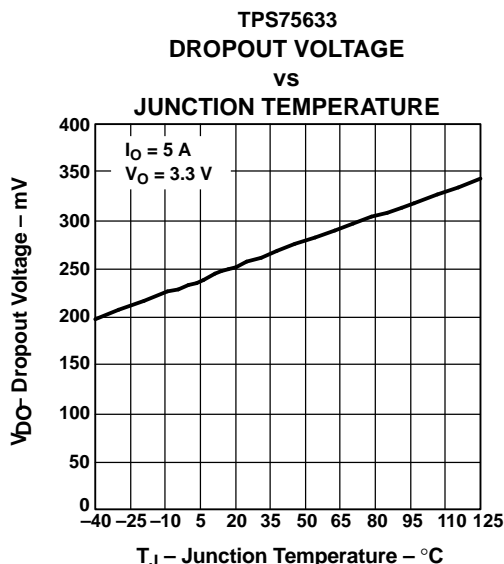
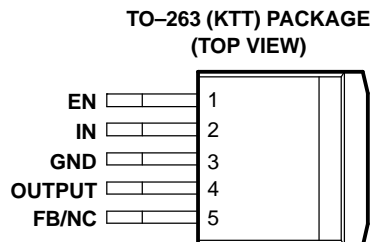
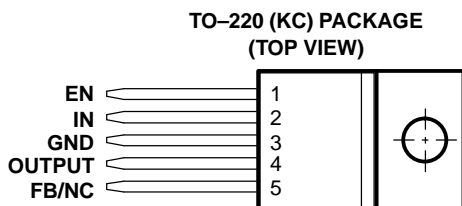

Please be aware that an important notice concerning availability, standard warranty, and use in critical applications of Texas Instruments semiconductor products and disclaimers thereto appears at the end of this data sheet.

PowerPAD is a trademark of Texas Instruments.

Because the PMOS device behaves as a low-value resistor, the dropout voltage is very low (typically 250 mV at an output current of 5 A for the TPS75633) and is directly proportional to the output current. Additionally, since the PMOS pass element is a voltage-driven device, the quiescent current is very low and independent of output loading (typically 125  $\mu$ A over the full range of output systems). These two key specifications yield a significant improvement in operating life for battery-powered systems.

The device is enabled when EN (enable) is connected to a high voltage level ( $> 2$  V). Applying a low voltage level ( $< 0.7$  V) to EN shuts down the regulator, reducing the quiescent current to less than 1  $\mu$ A at  $T_J = 25^\circ\text{C}$ .

The TPS756xx is offered in 1.5-V, 1.8-V, 2.5-V, and 3.3-V fixed-voltage versions and in an adjustable version (programmable over the range of 1.22 V to 5 V). Output voltage tolerance is specified as a maximum of 3% over line, load, and temperature ranges. The TPS756xx family is available in a 5-pin TO-220 (KC) and TO-263 (KTT) packages.

**AVAILABLE OPTIONS**

$T_J$	OUTPUT VOLTAGE (TYP)	TO-220 (KC)	TO-263(KTT) <sup>(1)</sup>
-40°C to +125°C	3.3 V	TPS75633KC	TPS75633KTT
	2.5 V	TPS75625KC	TPS75625KTT
	1.8 V	TPS75618KC	TPS75618KTT
	1.5 V	TPS75615KC	TPS75615KTT
	Adjustable 1.22 V to 5 V	TPS75601KC	TPS75601KTT

- (1) The TPS75601 is programmable using an external resistor divider (see application information). Add **T** for KTT devices in 50-piece reel. Add **R** for KTT devices in 500-piece reel.

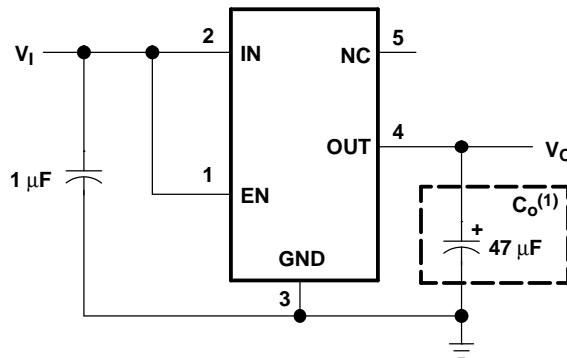

(1) See application information section for capacitor selection details.

**Figure 1. Typical Application Configuration (For Fixed Output Options)**

**FUNCTIONAL BLOCK DIAGRAM—ADJUSTABLE VERSION**

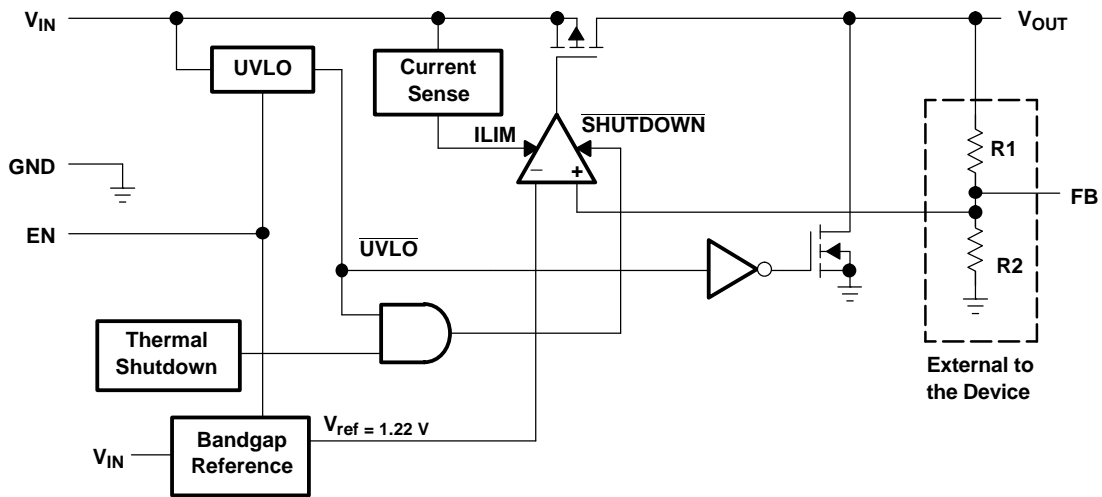

**FUNCTIONAL BLOCK DIAGRAM—FIXED VERSION**

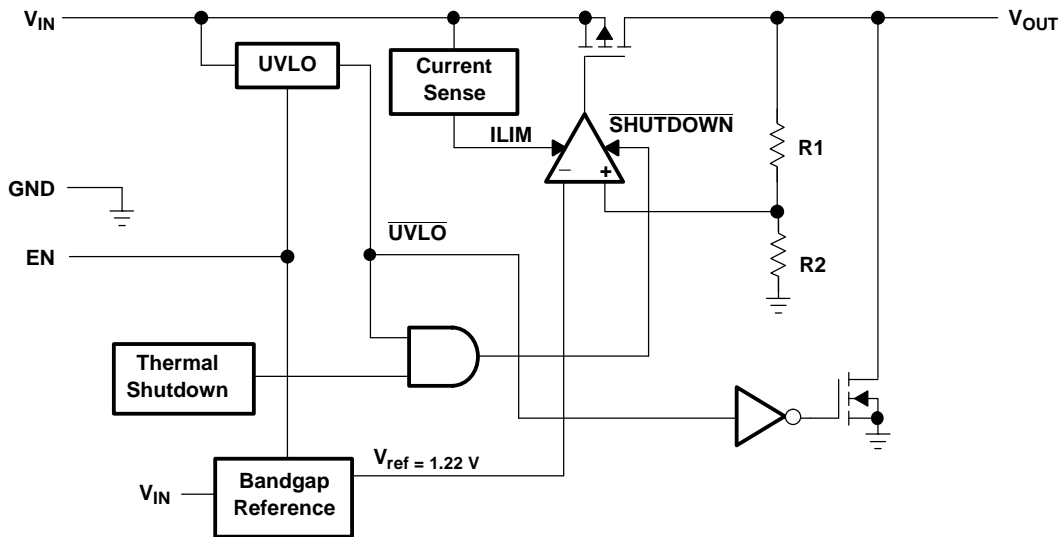

**TERMINAL FUNCTIONS (TPS756xx)**

TERMINAL NAME	NO.	I/O	DESCRIPTION
EN	1	I	Enable input
FB/NC	5	I	Feedback input voltage for adjustable device/no connection for fixed options
GND	3		Regulator ground
IN	2	I	Input voltage
OUTPUT	4	O	Regulated output voltage

## DETAILED DESCRIPTION

The TPS756xx family includes four fixed-output voltage regulators (1.5 V, 1.8 V, 2.5 V, and 3.3 V), and an adjustable regulator, the TPS75601 (adjustable from 1.22 V to 5 V). The bandgap voltage is typically 1.22 V.

### Pin Functions

#### Enable (EN)

The EN terminal is an input which enables or shuts down the device. If EN is a low voltage level (< 0.7 V), the device will be in shutdown or sleep mode. When EN goes to a high voltage level (> 2 V), the device will be enabled.

#### Feedback (FB)

FB is an input terminal used for the adjustable-output option and must be connected to the output terminal either directly, in order to generate the minimum output voltage of 1.22 V, or through an external feedback resistor divider for other output voltages. The FB connection should be as short as possible. It is essential to route it in such a way to minimize/avoid noise pickup. Adding RC networks between FB terminal and  $V_O$  to filter noise is not recommended because it may cause the regulator to oscillate.

#### Input Voltage (IN)

The  $V_{IN}$  terminal is an input to the regulator.

#### Output Voltage (OUTPUT)

The  $V_{OUTPUT}$  terminal is an output from the regulator.

### ABSOLUTE MAXIMUM RATINGS

over operating junction temperature range (unless otherwise noted)<sup>(1)(2)</sup>

	UNIT
Input voltage range, $V_I$	-0.3 V to 6 V
Voltage range at EN	-0.3 V to 6 V
Peak output current	Internally limited
Continuous total power dissipation	See Dissipation Rating Tables
Output voltage, $V_O$ (OUTPUT, FB)	5.5 V
Operating junction temperature range, $T_J$	-40°C to 150°C
Storage temperature range, $T_{stg}$	-65°C to 150°C
ESD rating, HBM	2 kV
ESD rating, CDM	500 V

- (1) Stresses beyond those listed under, "absolute maximum ratings" may cause permanent damage to the device. These are stress ratings only, and functional operation of the device at these or any other conditions beyond those indicated under, "recommended operating conditions" is not implied. Exposure to absolute-maximum-rated conditions for extended periods may affect device reliability.
- (2) All voltage values are with respect to network terminal ground.

### DISSIPATION RATING TABLE

package	$R_{\theta JC}$ (°C/W)	$R_{\theta JA}$ (°C/W) <sup>(1)</sup>
TO-220	2	58.7 <sup>(2)</sup>
TO-263	2	38.7 <sup>(3)</sup>

- (1) For both packages, the  $R_{\theta JA}$  values were computed using JEDEC high K board (2S2P) with 1 ounce internal copper plane and ground plane. There was no air flow across the packages.
- (2)  $R_{\theta JA}$  was computed assuming a vertical, free standing TO-220 package with pins soldered to the board. There is no heatsink attached to the package.
- (3)  $R_{\theta JA}$  was computed assuming a horizontally mounted TO-263 package with pins soldered to the board. There is no copper pad underneath the package.

## RECOMMENDED OPERATING CONDITIONS

	MIN	MAX	UNIT
Input voltage, $V_I^{(1)}$	2.8	5.5	V
Output voltage range, $V_O$	1.22	5	V
Output current, $I_O$	0	5	A
Operating virtual junction temperature, $T_J$	-40	125	°C

(1) To calculate the minimum input voltage for your maximum output current, use the following equation:  $V_{I(\min)} = V_{O(\max)} + V_{DO(\max \text{ load})}$ .

## ELECTRICAL CHARACTERISTICS

over recommended operating junction temperature range ( $T_J = -40^\circ\text{C}$  to  $125^\circ\text{C}$ ),  $V_I = V_O$  (typ) + 1 V,  $I_O = 1$  mA,  $EN = V_I$ ,  $C_o = 100$   $\mu\text{F}$  (unless otherwise noted)

PARAMETER	TEST CONDITIONS	MIN	TYP	MAX	UNIT	
Output voltage <sup>(1)</sup>	Adjustable voltage	$1.22 \text{ V} \leq V_O \leq 5.5 \text{ V}$ , $T_J = 25^\circ\text{C}$		$V_O$	V	
		$1.22 \text{ V} \leq V_O \leq 5.5 \text{ V}$		$0.97 V_O$ $1.03 V_O$		
		$1.22 \text{ V} \leq V_O \leq 5.5 \text{ V}$ , $T_J = 0$ to $125^\circ\text{C}^{(2)}$		$0.97 V_O$ $1.03 V_O$		
	1.5 V Output	$T_J = 25^\circ\text{C}$ , $2.8 \text{ V} < V_I < 5.5 \text{ V}$		1.5		V
		$2.8 \text{ V} \leq V_I \leq 5.5 \text{ V}$		1.455	1.545	
	1.8 V Output	$T_J = 25^\circ\text{C}$ , $2.8 \text{ V} < V_I < 5.5 \text{ V}$		1.8		V
		$2.8 \text{ V} \leq V_I \leq 5.5 \text{ V}$		1.746	1.854	
	2.5 V Output	$T_J = 25^\circ\text{C}$ , $3.5 \text{ V} < V_I < 5.5 \text{ V}$		2.5		V
		$3.5 \text{ V} \leq V_I \leq 5.5 \text{ V}$		2.425	2.575	
	3.3 V Output	$T_J = 25^\circ\text{C}$ , $4.3 \text{ V} < V_I < 5.5 \text{ V}$		3.3		V
		$4.3 \text{ V} \leq V_I \leq 5.5 \text{ V}$		3.201	3.399	
	Quiescent current (GND current) <sup>(1), (3)</sup>	$T_J = 25^\circ\text{C}$		125		$\mu\text{A}$
		200				
Output voltage line regulation ( $\Delta V_O/V_O$ ) <sup>(3)</sup>	$V_O + 1 \text{ V} \leq V_I \leq 5.5 \text{ V}$ , $T_J = 25^\circ\text{C}$		0.04		%V	
	$V_O + 1 \text{ V} \leq V_I < 5.5 \text{ V}$		0.1			
Load regulation <sup>(1)</sup>			0.35		%V	
Output noise voltage	TPS75615	BW = 300 Hz to 50 kHz, $T_J = 25^\circ\text{C}$ , $V_I = 2.8 \text{ V}$		35	$\mu\text{Vrms}$	
Output current limit	$V_O = 0 \text{ V}$		5.5	10	14	A
Thermal shutdown junction temperature			150		°C	
Standby current	EN = 0 $T_J = 25^\circ\text{C}$		0.1		$\mu\text{A}$	
	EN = 0		10		$\mu\text{A}$	
FB input current	TPS75601	FB = 1.5 V		-1	1	$\mu\text{A}$
Power supply ripple rejection	TPS75615	f = 100 Hz, $T_J = 25^\circ\text{C}$ , $V_I = 2.8 \text{ V}$ , $I_O = 5 \text{ A}$		60		dB
Input current ( $\overline{EN}$ )	EN = $V_I$		-1	1		$\mu\text{A}$
	EN = 0 V		-1	0	1	$\mu\text{A}$
High level EN input voltage			2		V	
Low level EN input voltage			0.7		V	

(1)  $I_O = 1$  mA to 5 A

(2) The adjustable option operates with a 2% tolerance over  $T_J = 0$  to  $125^\circ\text{C}$ .

(3) If  $V_O < 2.5 \text{ V}$  then  $V_{I\min} = 2.8 \text{ V}$ ,  $V_{I\max} = 5.5 \text{ V}$ :

$$\text{Line regulator (mV)} = (\%V) \times \frac{V_O(V_{I\max} - 2.8V)}{100} \times 1000$$

If  $V_O \geq 2.5 \text{ V}$  then  $V_{I\min} = V_O + 1 \text{ V}$ ,  $V_{I\max} = 5.5 \text{ V}$ :

$$\text{Line regulator (mV)} = (\%V) \times \frac{V_O(V_{I\max} - (V_O + 1V))}{100} \times 1000$$

## ELECTRICAL CHARACTERISTICS (continued)

over recommended operating junction temperature range ( $T_J = -40^\circ\text{C}$  to  $125^\circ\text{C}$ ),  $V_I = V_O$  (typ) + 1 V,  $I_O = 1$  mA,  $EN = V_I$ ,  $C_O = 100$   $\mu\text{F}$  (unless otherwise noted)

PARAMETER		TEST CONDITIONS	MIN	TYP	MAX	UNIT
$V_O$	Dropout voltage, (3.3 V output) <sup>(4)</sup>	$I_O = 5$ A, $V_I = 3.2$ V, $T_J = 25^\circ\text{C}$		250		mV
		$I_O = 5$ A, $V_I = 3.2$ V			500	
	Discharge transistor current	$V_O = 1.5$ V, $T_J = 25^\circ\text{C}$	10	25		mA
$V_I$	UVLO	$T_J = 25^\circ\text{C}$ , $V_I$ rising	2.2		2.75	V
	UVLO hysteresis	$T_J = 25^\circ\text{C}$ , $V_I$ falling		100		mV

(4) If  $V_O < 2.5$  V then  $V_{I\text{min}} = 2.8$  V,  $V_{I\text{max}} = 5.5$  V:

$$\text{Line regulator (mV)} = (\%V) \times \frac{V_O(V_{I\text{max}} - 2.8V)}{100} \times 1000$$

If  $V_O \geq 2.5$  V then  $V_{I\text{min}} = V_O + 1$  V,  $V_{I\text{max}} = 5.5$  V:

$$\text{Line regulator (mV)} = (\%V) \times \frac{V_O(V_{I\text{max}} - (V_O + 1V))}{100} \times 1000$$

## TYPICAL CHARACTERISTICS

### Table of Graphs

			FIGURE
$V_O$	Output voltage	vs Output current	2, 3
		vs Junction temperature	4, 5
	Ground current	vs Junction temperature	6
	Power supply ripple rejection	vs Frequency	7
	Output spectral noise density	vs Frequency	8
$z_o$	Output impedance	vs Frequency	9
$V_{DO}$	Dropout voltage	vs Input voltage	10
		vs Junction temperature	11
$V_I$	Minimum required input voltage	vs Output voltage	12
	Line transient response		13, 15
	Load transient response		14, 16
$V_O$	Output voltage and enable voltage	vs Time (start-up)	17
	Equivalent series resistance	vs Output current	19, 20

**TPS75633**  
**OUTPUT VOLTAGE**  
**vs**  
**OUTPUT CURRENT**

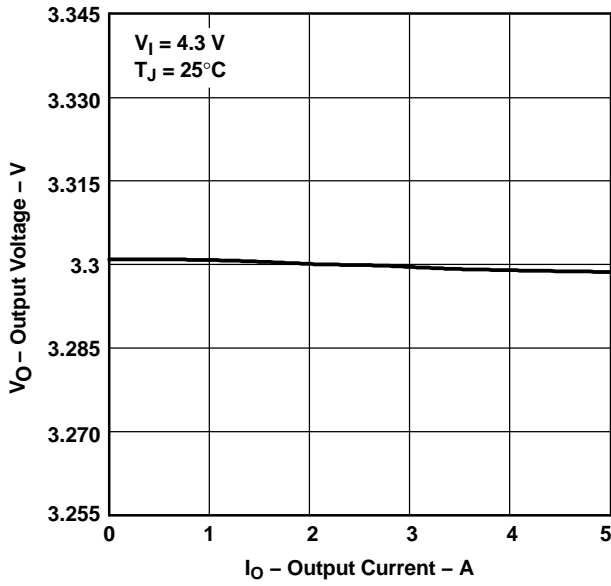

Figure 2.

**TPS75615**  
**OUTPUT VOLTAGE**  
**vs**  
**OUTPUT CURRENT**

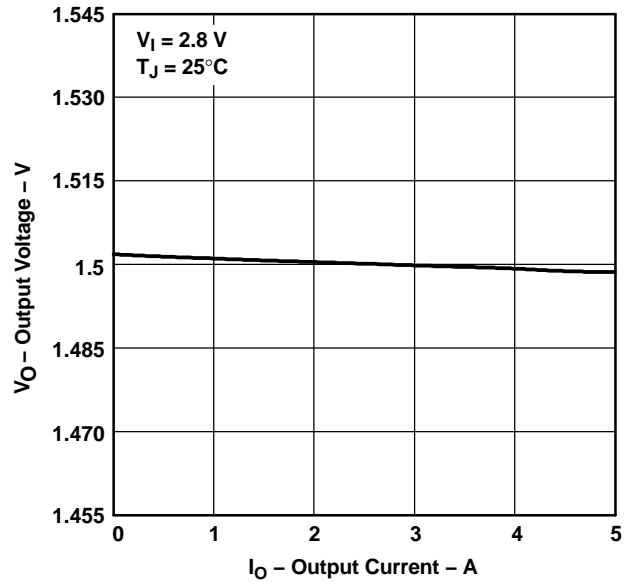

Figure 3.

**TPS75633**  
**OUTPUT VOLTAGE**  
**vs**  
**JUNCTION TEMPERATURE**

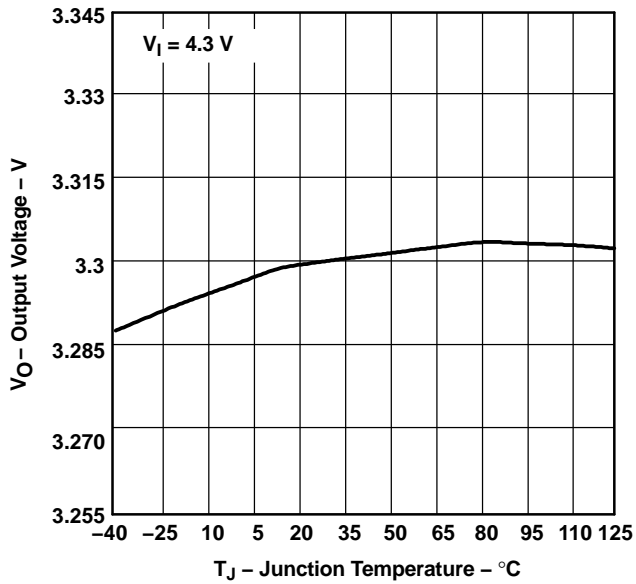

Figure 4.

**TPS75615**  
**OUTPUT VOLTAGE**  
**vs**  
**JUNCTION TEMPERATURE**

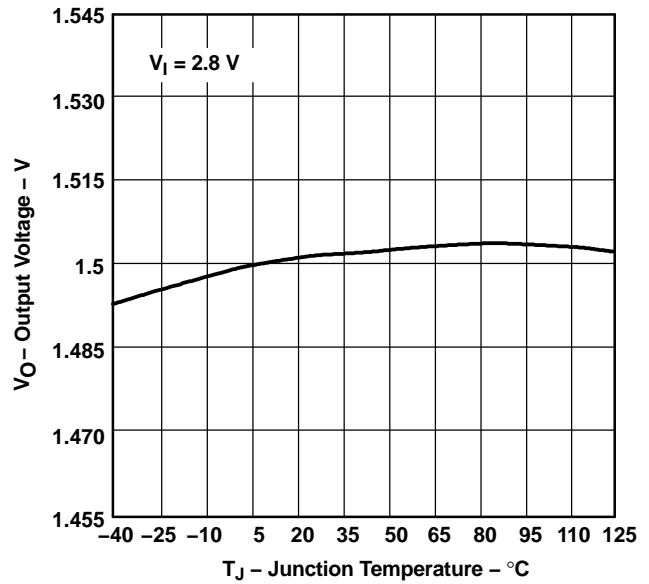
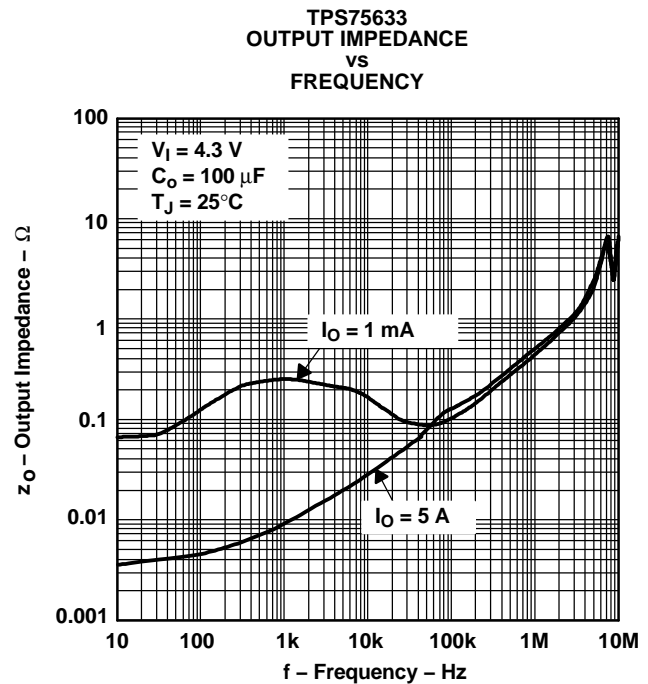
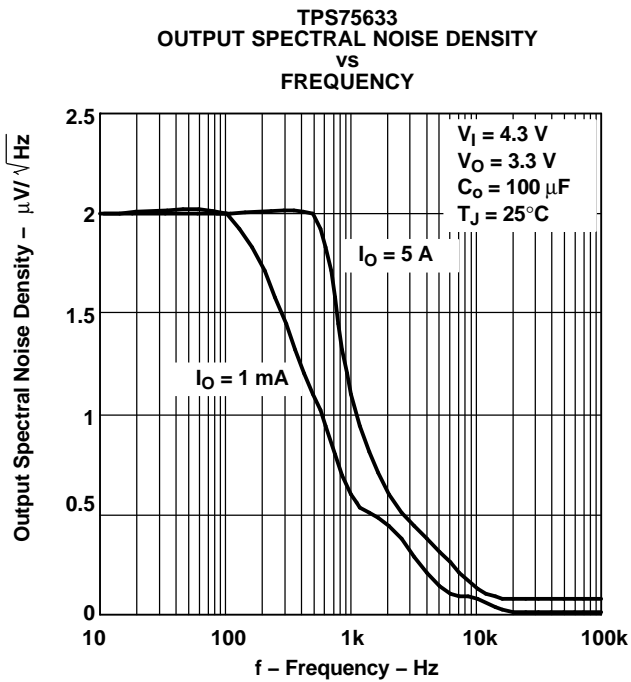
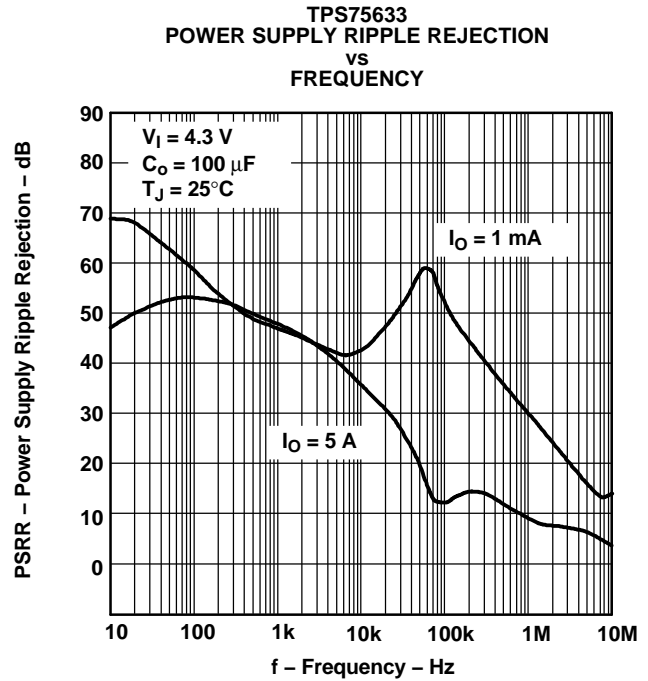
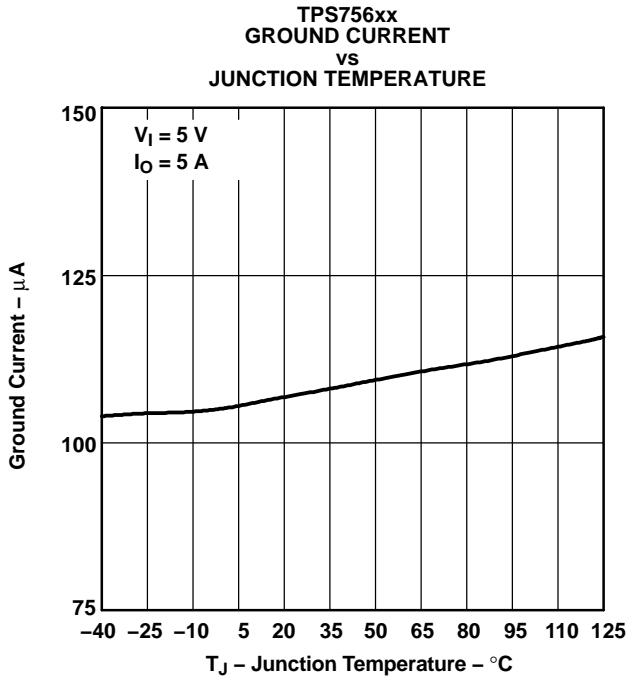

Figure 5.

TYPICAL CHARACTERISTICS (continued)



**TYPICAL CHARACTERISTICS (continued)**

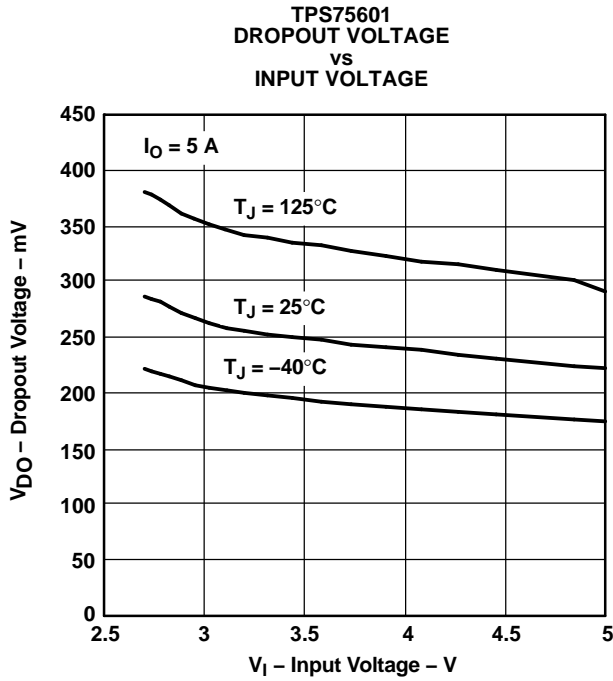

Figure 10.

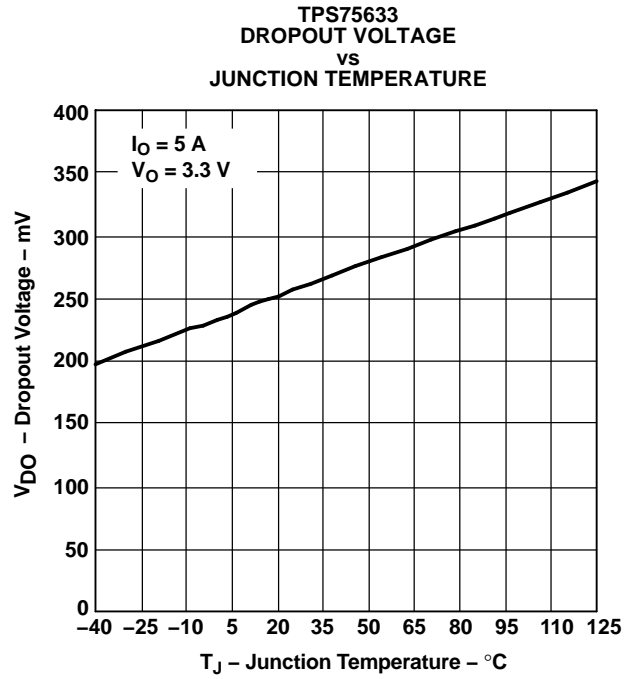

Figure 11.

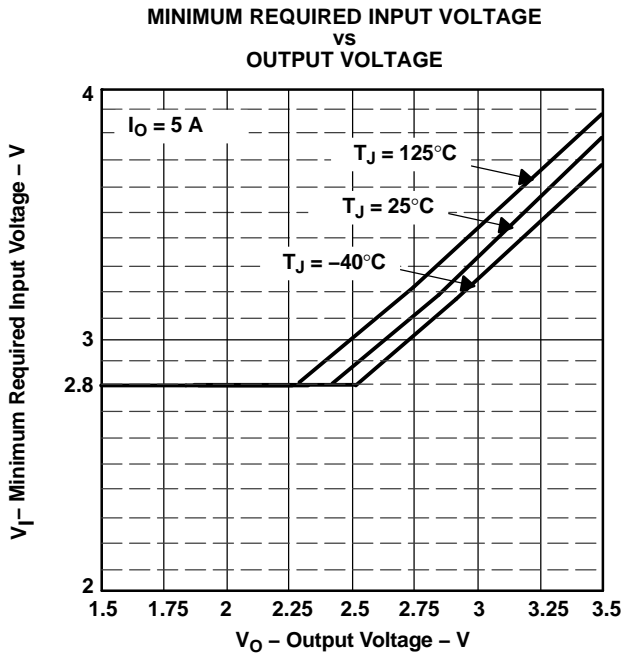

Figure 12.

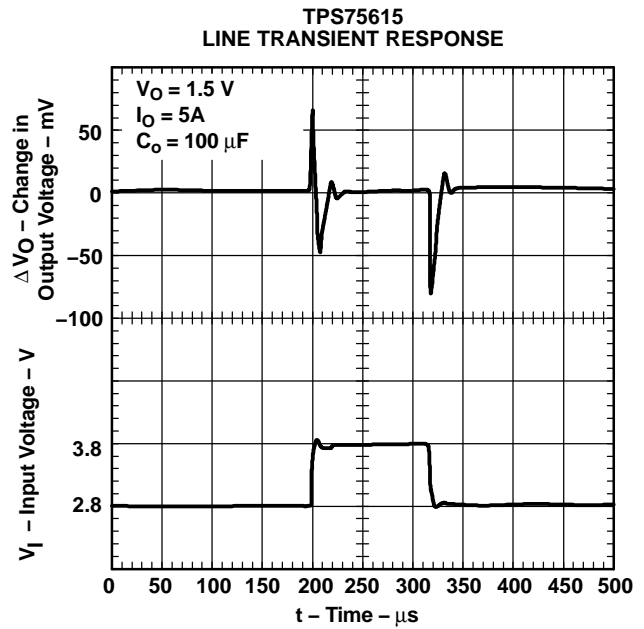

Figure 13.

TYPICAL CHARACTERISTICS (continued)

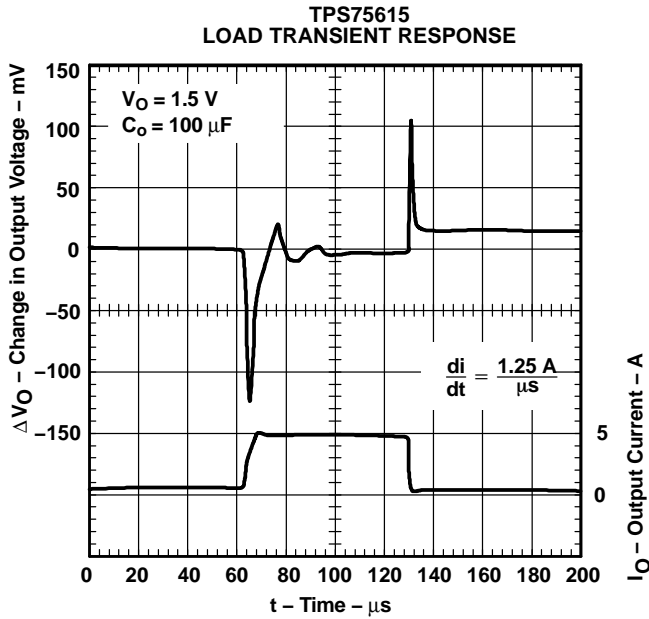

Figure 14.

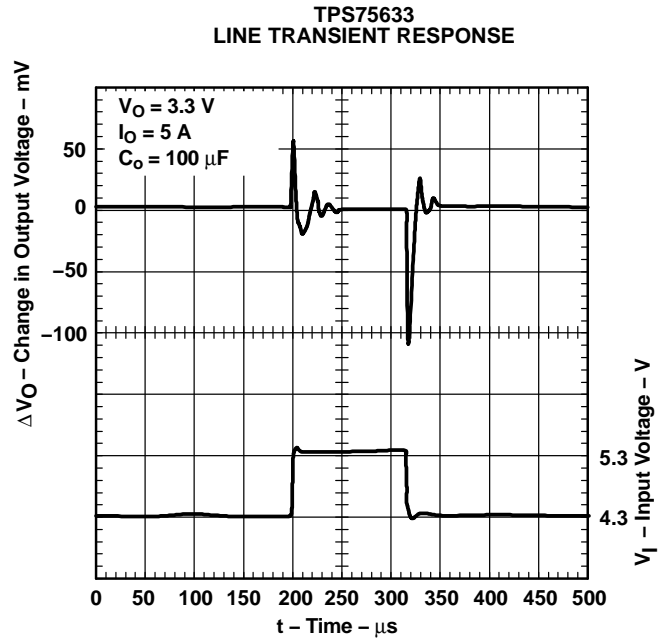

Figure 15.

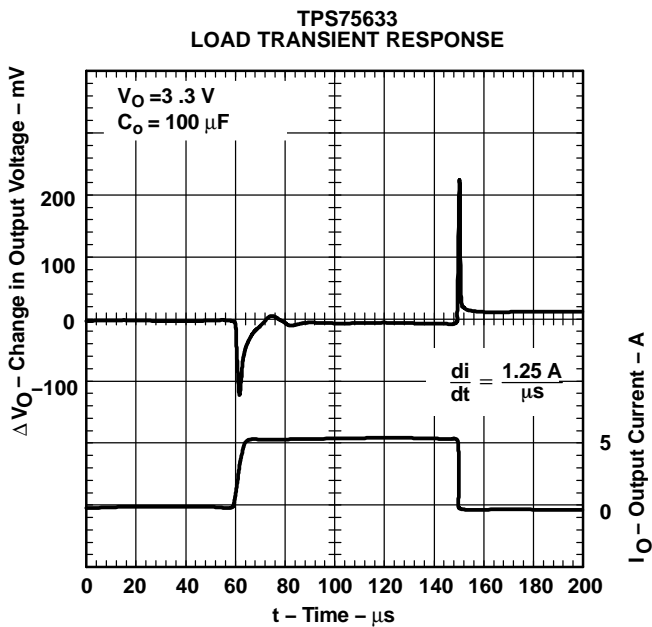

Figure 16.

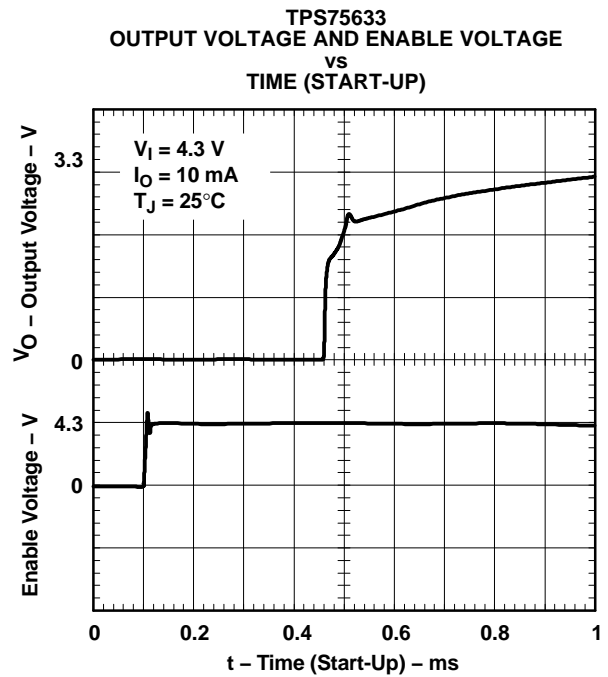

Figure 17.

TYPICAL CHARACTERISTICS (continued)

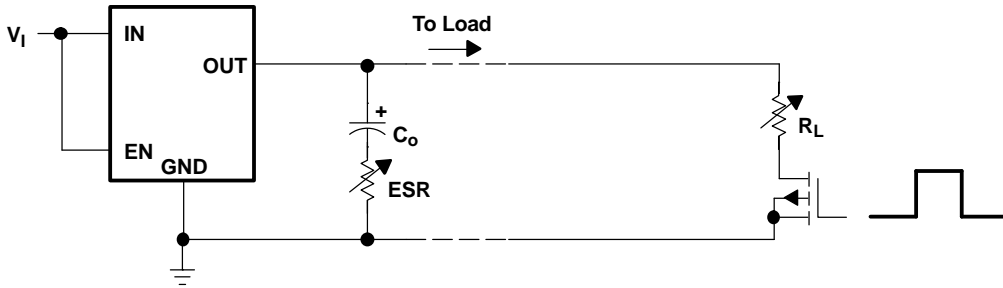

Figure 18. Test Circuit for Typical Regions of Stability (Figures 19 and 20) (Fixed Output Options)

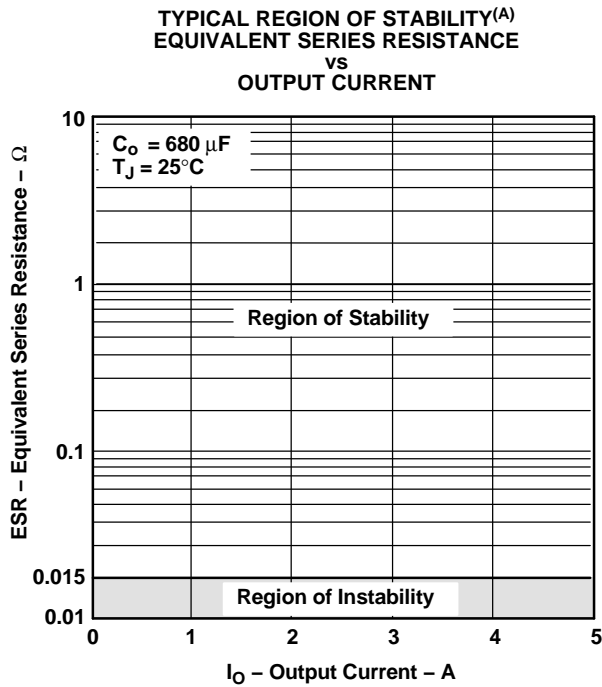

Figure 19.

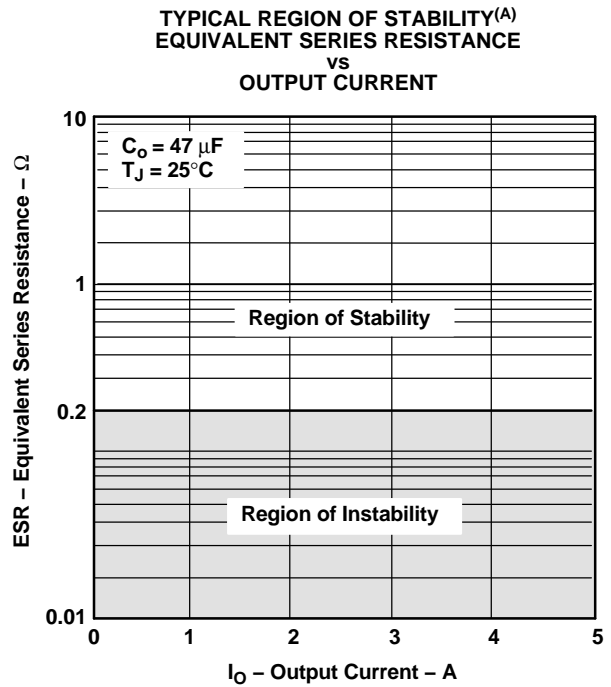

Figure 20.

A. Equivalent series resistance (ESR) refers to the total series resistance, including the ESR of the capacitor, any series resistance added externally, and PWB trace resistance to  $C_O$ .

## THERMAL INFORMATION

The amount of heat that an LDO linear regulator generates is directly proportional to the amount of power it dissipates during operation. All integrated circuits have a maximum allowable junction temperature ( $T_{J,max}$ ) above which normal operation is not assured. A system designer must design the operating environment so that the operating junction temperature ( $T_J$ ) does not exceed the maximum junction temperature ( $T_{J,max}$ ). The two main environmental variables that a designer can use to improve thermal performance are air flow and external heatsinks. The purpose of this information is to aid the designer in determining the proper operating environment for a linear regulator that is operating at a specific power level.

In general, the maximum expected power ( $P_{D(max)}$ ) consumed by a linear regulator is computed as:

$$P_{D,max} = (V_{I(avg)} - V_{O(avg)}) \times I_{O(avg)} + V_{I(avg)} \times I_{(Q)} \quad (1)$$

Where:

- $V_{I(avg)}$  is the average input voltage.
- $V_{O(avg)}$  is the average output voltage.
- $I_{O(avg)}$  is the average output current.
- $I_{(Q)}$  is the quiescent current.

For most TI LDO regulators, the quiescent current is insignificant compared to the average output current; therefore, the term  $V_{I(avg)} \times I_{(Q)}$  can be neglected. The operating junction temperature is computed by adding the ambient temperature ( $T_A$ ) and the increase in temperature due to the regulator's power dissipation. The temperature rise is computed by multiplying the maximum expected power dissipation by the sum of the thermal resistances between the junction and the case ( $R_{\theta JC}$ ), the case to heatsink ( $R_{\theta CS}$ ), and the heatsink to ambient ( $R_{\theta SA}$ ). Thermal resistances are measures of how effectively an object dissipates heat. Typically, the larger the device, the more surface area available for power dissipation and the lower the object's thermal resistance.

Figure 21 illustrates these thermal resistances for (a) a TO-220 package attached to a heatsink, and (b) a TO-263 package mounted on a JEDEC High-K board.

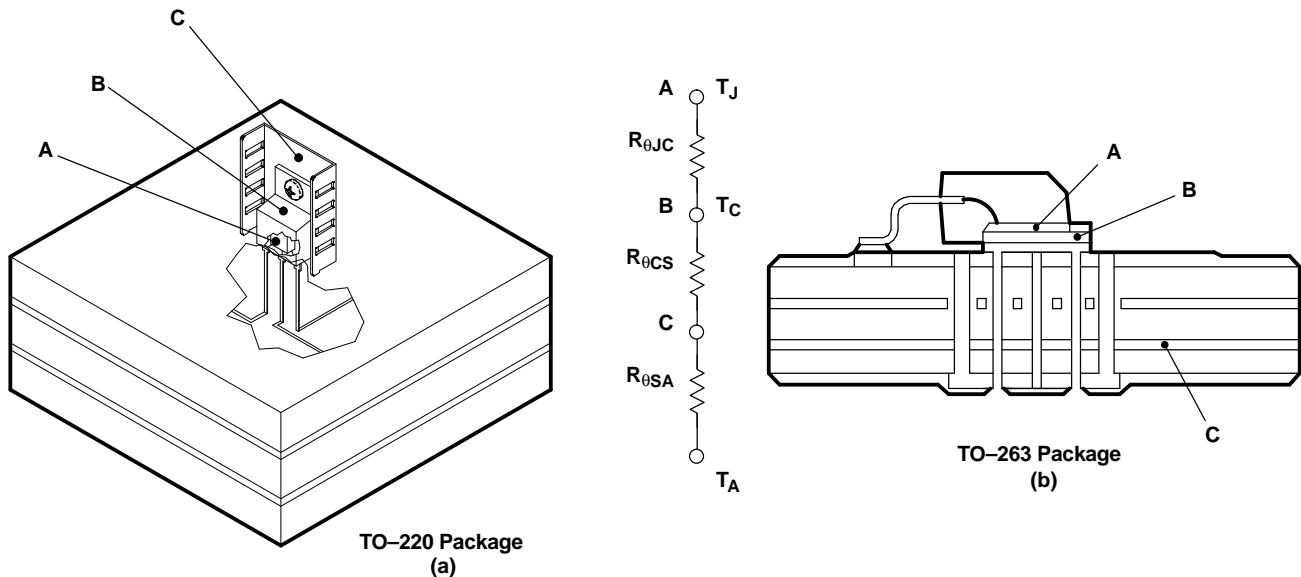

Figure 21. Thermal Resistances

## THERMAL INFORMATION (continued)

Equation 2 summarizes the computation:

$$T_J = T_A + P_{Dmax} \times (R_{\theta JC} + R_{\theta CS} + R_{\theta SA}) \quad (2)$$

The  $R_{\theta JC}$  is specific to each regulator as determined by its package, lead frame, and die size provided in the regulator's data sheet. The  $R_{\theta SA}$  is a function of the type and size of heatsink. For example, *black body radiator* type heatsinks, like the one attached to the TO-220 package in Figure 21(a), can have  $R_{\theta CS}$  values ranging from 5 °C/W for very large heatsinks to 50 °C/W for very small heatsinks. The  $R_{\theta CS}$  is a function of how the package is attached to the heatsink. For example, if a thermal compound is used to attach a heatsink to a TO-220 package,  $R_{\theta CS}$  of 1°C/W is reasonable.

Even if no external *black body radiator* type heatsink is attached to the package, the board on which the regulator is mounted will provide some heatsinking through the pin solder connections. Some packages, like the TO-263 and TI's TSSOP PowerPAD™ packages, use a copper plane underneath the package or the circuit board's ground plane for additional heatsinking to improve their thermal performance. Computer aided thermal modeling can be used to compute very accurate approximations of an integrated circuit's thermal performance in different operating environments (e.g., different types of circuit boards, different types and sizes of heatsinks, different air flows, etc.). Using these models, the three thermal resistances can be combined into one thermal resistance between junction and ambient ( $R_{\theta JA}$ ). This  $R_{\theta JA}$  is valid only for the specific operating environment used in the computer model.

Equation 2 simplifies into Equation 3:

$$T_J = T_A + P_{Dmax} \times R_{\theta JA} \quad (3)$$

Rearranging Equation 3 gives Equation 4:

$$R_{\theta JA} = \frac{T_J - T_A}{P_{Dmax}} \quad (4)$$

Using Equation 3 and the computer model generated curves shown in Figure 22 and Figure 25, a designer can quickly compute the required heatsink thermal resistance/board area for a given ambient temperature, power dissipation, and operating environment.

## TO-220 Power Dissipation

The TO-220 package provides an effective means of managing power dissipation in through-hole applications. The TO-220 package dimensions are provided in the *Mechanical Data* section at the end of the data sheet. A heatsink can be used with the TO-220 package to effectively lower the junction-to-ambient thermal resistance.

To illustrate, the TPS75625 in a TO-220 package was chosen. For this example, the average input voltage is 3.3 V, the average output voltage is 2.5 V, the average output current is 3 A, the ambient temperature 55°C, the air flow is 150 LFM, and the operating environment is the same as documented below. Neglecting the quiescent current, the maximum average power is:

$$P_{Dmax} = (3.3 - 2.5) \text{ V} \times 3 \text{ A} = 2.4 \text{ W} \quad (5)$$

Substituting  $T_{Jmax}$  for  $T_J$  into Equation 4 gives Equation 6:

$$R_{\theta JAmax} = (125 - 55)^\circ\text{C} / 2.4 \text{ W} = 29^\circ\text{C/W} \quad (6)$$

From Figure 22,  $R_{\theta JA}$  vs Heatsink Thermal Resistance, a heatsink with  $R_{\theta SA} = 22^\circ\text{C/W}$  is required to dissipate 2.4 W. The model operating environment used in the computer model to construct Figure 22 consisted of a standard JEDEC High-K board (2S2P) with a 1 oz. internal copper plane and ground plane. Since the package pins were soldered to the board, 450 mm<sup>2</sup> of the board was modeled as a heatsink. Figure 23 shows the side view of the operating environment used in the computer model.

THERMAL INFORMATION (continued)

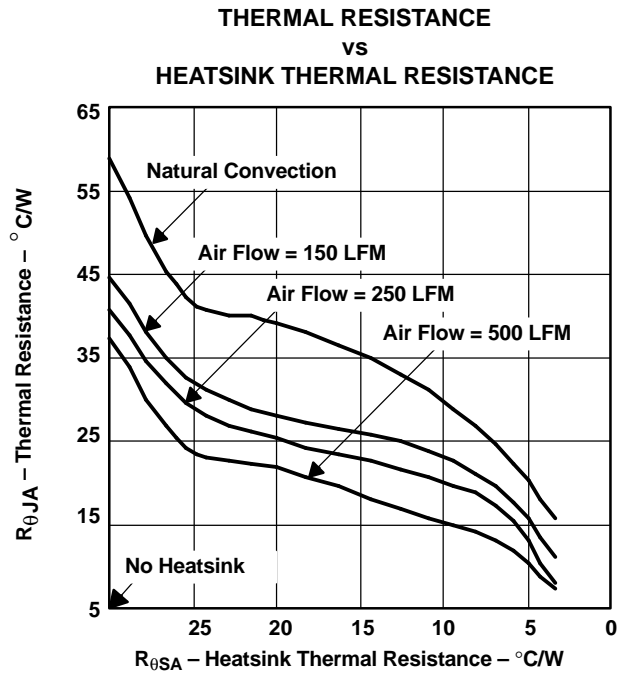

Figure 22.

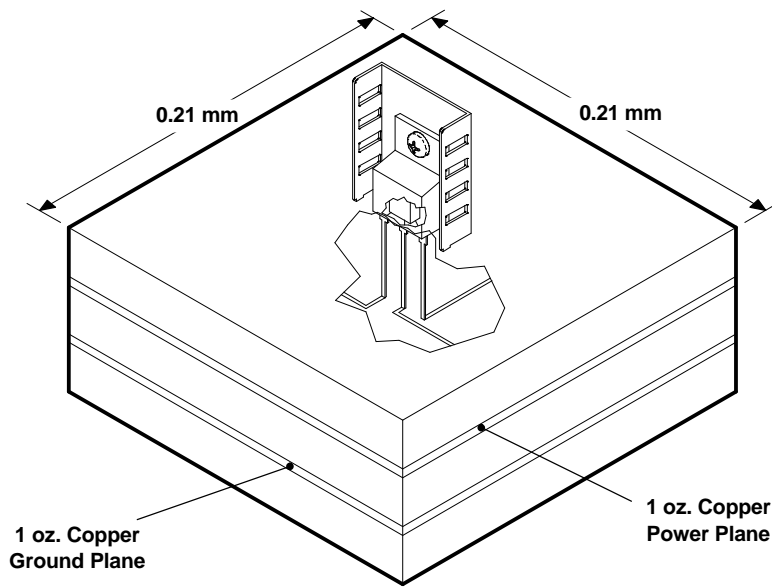

Figure 23.

From the data in Figure 22 and rearranging Equation 4, the maximum power dissipation for a different heatsink  $R_{\theta SA}$  and a specific ambient temperature can be computed (see Figure 24).

THERMAL INFORMATION (continued)

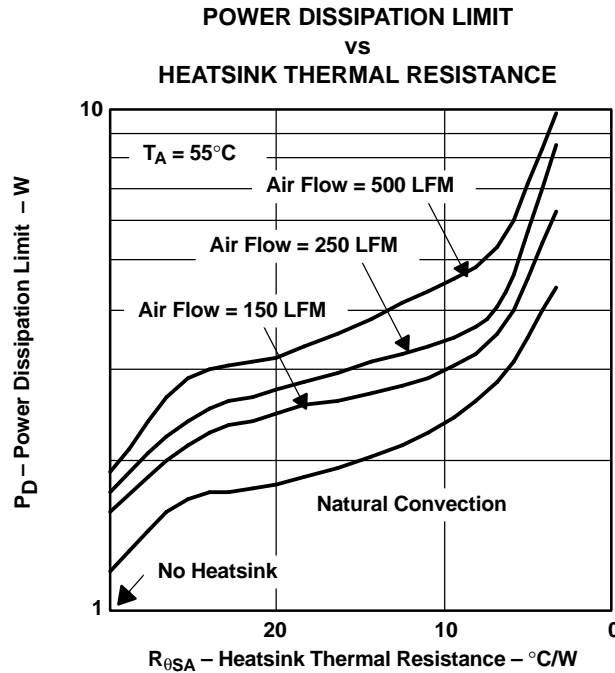

Figure 24.

**TO-263 Power Dissipation**

The TO-263 package provides an effective means of managing power dissipation in surface-mount applications. The TO-263 package dimensions are provided in the *Mechanical Data* section at the end of the data sheet. The addition of a copper plane directly underneath the TO-263 package enhances the thermal performance of the package.

To illustrate, the TPS75625 in a TO-263 package was chosen. For this example, the average input voltage is 3.3 V, the average output voltage is 2.5 V, the average output current is 3 A, the ambient temperature 55°C, the air flow is 150 LFM, and the operating environment is the same as documented below. Neglecting the quiescent current, the maximum average power is:

$$P_{Dmax} = (3.3 - 2.5) V \times 3 A = 2.4 W \tag{7}$$

Substituting T<sub>Jmax</sub> for T<sub>J</sub> into Equation 4 gives Equation 8:

$$R_{\theta JA} max = (125 - 55)^\circ C / 2.4 W = 29^\circ C/W \tag{8}$$

From Figure 25, R<sub>θJA</sub> vs Copper Heatsink Area, the ground plane needs to be 2 cm<sup>2</sup> for the part to dissipate 2.4 W. The model operating environment used in the computer model to construct Figure 25 consisted of a standard JEDEC High-K board (2S2P) with a 1 oz. internal copper plane and ground plane. The package is soldered to a 2 oz. copper pad. The pad is tied through thermal vias to the 1 oz. ground plane. Figure 26 shows the side view of the operating environment used in the computer model.

THERMAL INFORMATION (continued)

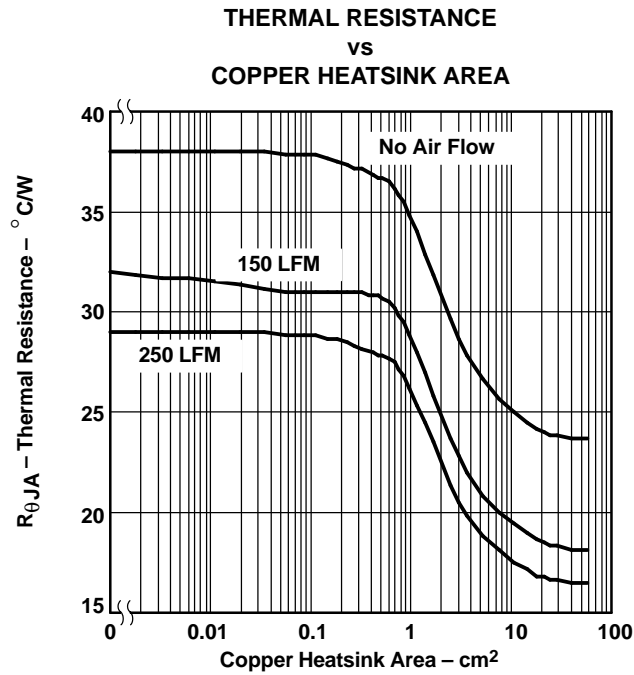

Figure 25.

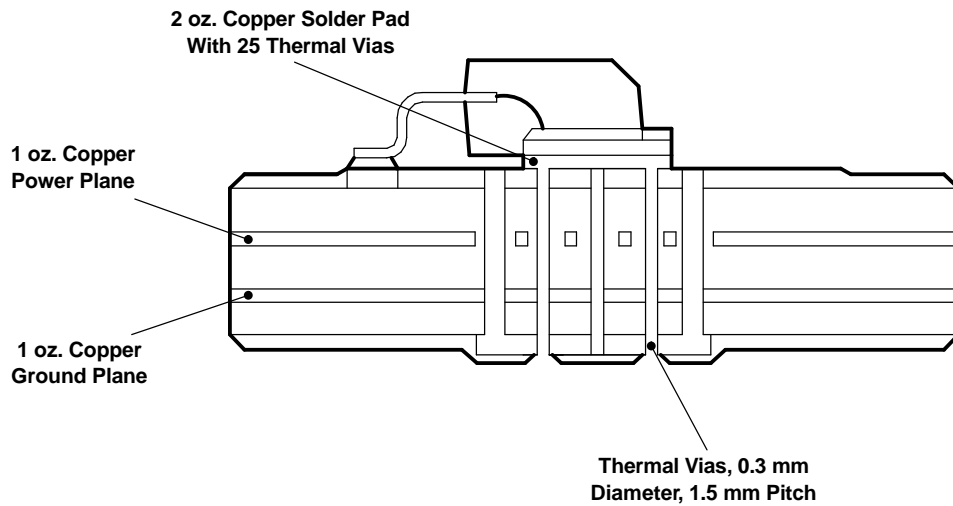

Figure 26.

From the data in Figure 25 and rearranging Equation 4, the maximum power dissipation for a different ground plane area and a specific ambient temperature can be computed (see Figure 27).

THERMAL INFORMATION (continued)

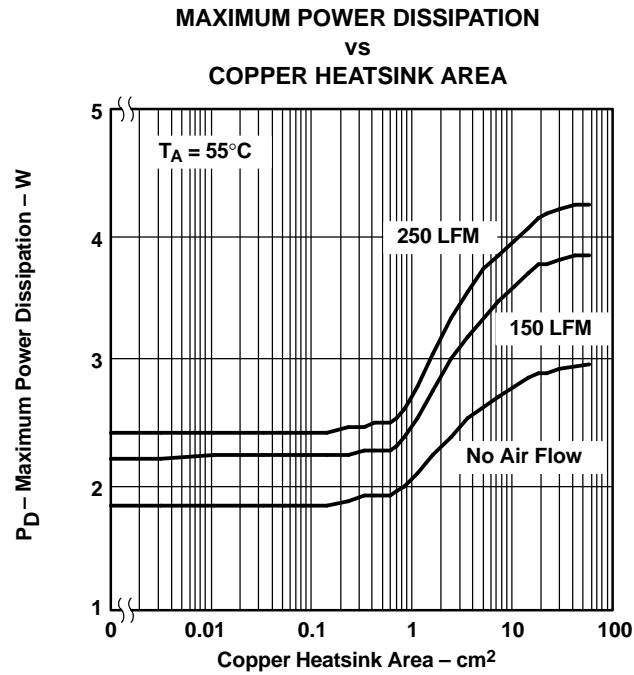

Figure 27.

## APPLICATION INFORMATION

The output voltage of the TPS75601 adjustable regulator is programmed using an external resistor divider as shown in Figure 28. The output voltage is calculated using:

$$\text{Line regulator (mV)} = (\%V) \times \frac{V_o(V_{I_{max}} - 2.8V)}{100} \times 1000 \quad (9)$$

Resistors R1 and R2 should be chosen for approximately 40- $\mu$ A divider current. Lower value resistors can be used but offer no inherent advantage and waste more power. Higher values should be avoided as leakage currents at FB increase the output voltage error. The recommended design procedure is to choose R2 = 30.1 k $\Omega$  to set the divider current at 40  $\mu$ A and then calculate R1 using:

$$R1 = \left( \frac{V_o}{V_{ref}} - 1 \right) \times R2 \quad (10)$$

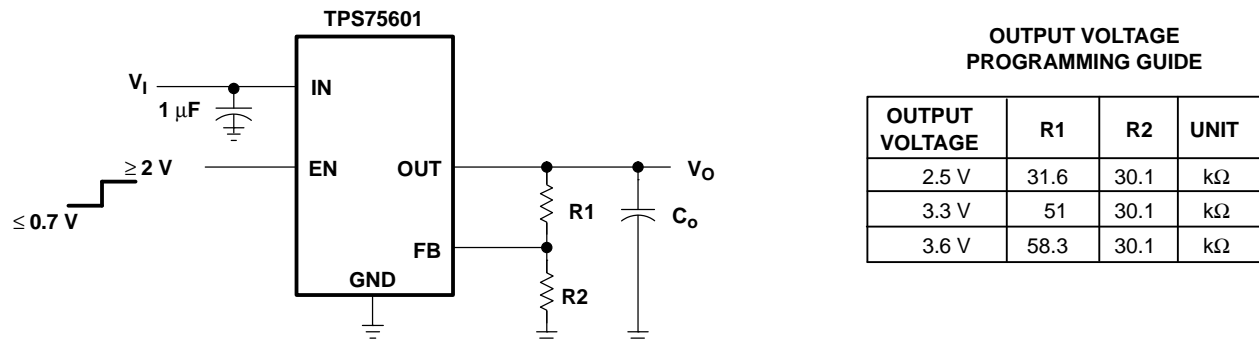

Figure 28. TPS75601 Adjustable LDO Regulator Programming

### Regulator Protection

The TPS756xx PMOS-pass transistor has a built-in back diode that conducts reverse currents when the input voltage drops below the output voltage (e.g., during power down). Current is conducted from the output to the input and is not internally limited. When extended reverse voltage is anticipated, external limiting may be appropriate.

The TPS756xx also features internal current limiting and thermal protection. During normal operation, the TPS756xx limits output current to approximately 10 A. When current limiting engages, the output voltage scales back linearly until the overcurrent condition ends. While current limiting is designed to prevent gross device failure, care should be taken not to exceed the power dissipation ratings of the package. If the temperature of the device exceeds 150°C (typ), thermal-protection circuitry shuts it down. Once the device has cooled below 130°C (typ), regulator operation resumes.

### Input Capacitor

For a typical application, a ceramic input bypass capacitor (0.22  $\mu$ F-1  $\mu$ F) is recommended to ensure device stability. This capacitor should be as close as possible to the input pin. Due to the impedance of the input supply, large transient currents will cause the input voltage to droop. If this droop causes the input voltage to drop below the UVLO threshold, the device will turn off. Therefore, it is recommended that a larger capacitor be placed in parallel with the ceramic bypass capacitor at the regulator's input. The size of this capacitor depends on the output current, response time of the main power supply, and the main power supply's distance to the regulator. At a minimum, the capacitor should be sized to ensure that the input voltage does not drop below the minimum UVLO threshold voltage during normal operating conditions.

**APPLICATION INFORMATION (continued)**

**Output Capacitor**

As with most LDO regulators, the TPS756xx requires an output capacitor connected between OUT and GND to stabilize the internal control loop. The minimum recommended capacitance value is 47  $\mu\text{F}$  with an ESR (equivalent series resistance) of at least 200  $\text{m}\Omega$ . As shown in Figure 29, most capacitor and ESR combinations with a product of  $47\text{e-}6 \times 0.2 = 9.4\text{e-}6$  or larger will be stable, provided the capacitor value is at least 47  $\mu\text{F}$ . Solid tantalum electrolytic and aluminum electrolytic capacitors are all suitable, provided they meet the requirements described in this section. Larger capacitors provide a wider range of stability and better load transient response.

This information along with the ESR graphs, Figure 19, Figure 20, and Figure 29, is included to assist in selection of suitable capacitance for the user's application. When necessary to achieve low height requirements along with high output current and/or high load capacitance, several higher ESR capacitors can be used in parallel to meet these guidelines.

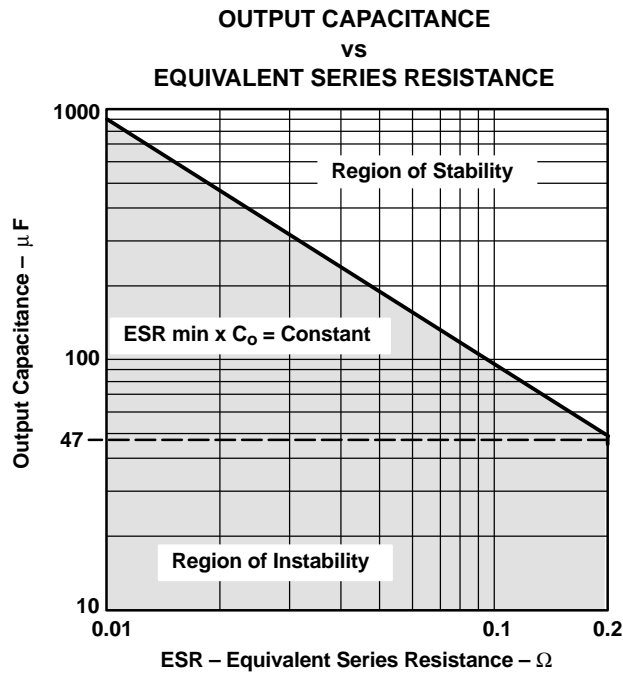

**Figure 29.**

**PACKAGING INFORMATION**

Orderable Device	Status (1)	Package Type	Package Drawing	Pins	Package Qty	Eco Plan (2)	Lead finish/ Ball material (6)	MSL Peak Temp (3)	Op Temp (°C)	Device Marking (4/5)	Samples
TPS75601KC	ACTIVE	TO-220	KC	5	50	RoHS & Green	Call TI   SN	N / A for Pkg Type	-40 to 85	75601	<a href="#">Samples</a>
TPS75601KTTR	ACTIVE	DDPAK/ TO-263	KTT	5	500	RoHS & Green	Call TI   SN	Level-2-260C-1 YEAR	-40 to 85	75601	<a href="#">Samples</a>
TPS75601KTTRG3	ACTIVE	DDPAK/ TO-263	KTT	5	500	RoHS & Green	SN	Level-2-260C-1 YEAR	-40 to 85	75601	<a href="#">Samples</a>
TPS75615KC	ACTIVE	TO-220	KC	5	50	RoHS & Green	Call TI   SN	N / A for Pkg Type	-40 to 85	75615	<a href="#">Samples</a>
TPS75615KCG3	ACTIVE	TO-220	KC	5	50	RoHS & Green	SN	N / A for Pkg Type	-40 to 85	75615	<a href="#">Samples</a>
TPS75615KTTT	ACTIVE	DDPAK/ TO-263	KTT	5	50	RoHS & Green	Call TI   SN	Level-2-260C-1 YEAR		75615	<a href="#">Samples</a>
TPS75615KTTTG3	ACTIVE	DDPAK/ TO-263	KTT	5	50	RoHS & Green	SN	Level-2-260C-1 YEAR		75615	<a href="#">Samples</a>
TPS75618KC	ACTIVE	TO-220	KC	5	50	RoHS & Green	Call TI   SN	N / A for Pkg Type	-40 to 85	75618	<a href="#">Samples</a>
TPS75618KTTT	ACTIVE	DDPAK/ TO-263	KTT	5	50	RoHS & Green	Call TI   SN	Level-2-260C-1 YEAR		75618	<a href="#">Samples</a>
TPS75618KTTTG3	ACTIVE	DDPAK/ TO-263	KTT	5	50	RoHS & Green	SN	Level-2-260C-1 YEAR		75618	<a href="#">Samples</a>
TPS75625KC	ACTIVE	TO-220	KC	5	50	RoHS & Green	Call TI   SN	N / A for Pkg Type	-40 to 85	75625	<a href="#">Samples</a>
TPS75625KTTR	ACTIVE	DDPAK/ TO-263	KTT	5	500	RoHS & Green	Call TI   SN	Level-2-260C-1 YEAR	-40 to 85	75625	<a href="#">Samples</a>
TPS75633KC	ACTIVE	TO-220	KC	5	50	RoHS & Green	Call TI   SN	N / A for Pkg Type	-40 to 85	75633	<a href="#">Samples</a>
TPS75633KCG3	ACTIVE	TO-220	KC	5	50	RoHS & Green	SN	N / A for Pkg Type	-40 to 85	75633	<a href="#">Samples</a>
TPS75633KTTT	ACTIVE	DDPAK/ TO-263	KTT	5	50	RoHS & Green	Call TI   SN	Level-2-260C-1 YEAR		75633	<a href="#">Samples</a>
TPS75633KTTTG3	ACTIVE	DDPAK/ TO-263	KTT	5	50	RoHS & Green	SN	Level-2-260C-1 YEAR		75633	<a href="#">Samples</a>

(1) The marketing status values are defined as follows:

**ACTIVE:** Product device recommended for new designs.

**LIFEBUY:** TI has announced that the device will be discontinued, and a lifetime-buy period is in effect.

**NRND:** Not recommended for new designs. Device is in production to support existing customers, but TI does not recommend using this part in a new design.

**PREVIEW:** Device has been announced but is not in production. Samples may or may not be available.

**OBSELETE:** TI has discontinued the production of the device.

<sup>(2)</sup> **RoHS:** TI defines "RoHS" to mean semiconductor products that are compliant with the current EU RoHS requirements for all 10 RoHS substances, including the requirement that RoHS substance do not exceed 0.1% by weight in homogeneous materials. Where designed to be soldered at high temperatures, "RoHS" products are suitable for use in specified lead-free processes. TI may reference these types of products as "Pb-Free".

**RoHS Exempt:** TI defines "RoHS Exempt" to mean products that contain lead but are compliant with EU RoHS pursuant to a specific EU RoHS exemption.

**Green:** TI defines "Green" to mean the content of Chlorine (Cl) and Bromine (Br) based flame retardants meet JS709B low halogen requirements of  $\leq 1000$ ppm threshold. Antimony trioxide based flame retardants must also meet the  $\leq 1000$ ppm threshold requirement.

<sup>(3)</sup> MSL, Peak Temp. - The Moisture Sensitivity Level rating according to the JEDEC industry standard classifications, and peak solder temperature.

<sup>(4)</sup> There may be additional marking, which relates to the logo, the lot trace code information, or the environmental category on the device.

<sup>(5)</sup> Multiple Device Markings will be inside parentheses. Only one Device Marking contained in parentheses and separated by a "~" will appear on a device. If a line is indented then it is a continuation of the previous line and the two combined represent the entire Device Marking for that device.

<sup>(6)</sup> Lead finish/Ball material - Orderable Devices may have multiple material finish options. Finish options are separated by a vertical ruled line. Lead finish/Ball material values may wrap to two lines if the finish value exceeds the maximum column width.

**Important Information and Disclaimer:** The information provided on this page represents TI's knowledge and belief as of the date that it is provided. TI bases its knowledge and belief on information provided by third parties, and makes no representation or warranty as to the accuracy of such information. Efforts are underway to better integrate information from third parties. TI has taken and continues to take reasonable steps to provide representative and accurate information but may not have conducted destructive testing or chemical analysis on incoming materials and chemicals. TI and TI suppliers consider certain information to be proprietary, and thus CAS numbers and other limited information may not be available for release.

In no event shall TI's liability arising out of such information exceed the total purchase price of the TI part(s) at issue in this document sold by TI to Customer on an annual basis.

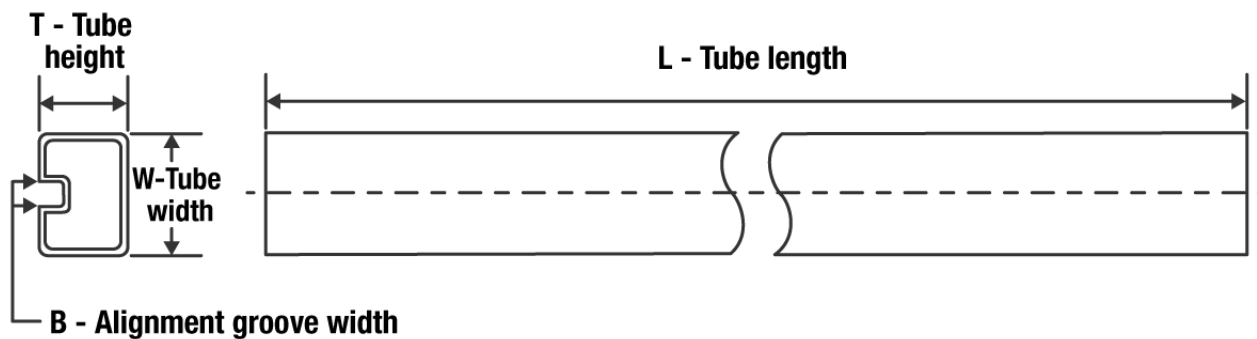
**TUBE**

\*All dimensions are nominal

Device	Package Name	Package Type	Pins	SPQ	L (mm)	W (mm)	T (μm)	B (mm)
TPS75601KC	KC	TO-220	5	50	546	31	11930	3.17
TPS75601KC	KC	TO-220	5	50	546	31	11930	3.17
TPS75615KC	KC	TO-220	5	50	546	31	11930	3.17
TPS75615KCG3	KC	TO-220	5	50	546	31	11930	3.17
TPS75618KC	KC	TO-220	5	50	546	31	11930	3.17
TPS75625KC	KC	TO-220	5	50	546	31	11930	3.17
TPS75633KC	KC	TO-220	5	50	546	31	11930	3.17
TPS75633KCG3	KC	TO-220	5	50	546	31	11930	3.17

KTT (R-PSFM-G5)

PLASTIC FLANGE-MOUNT PACKAGE

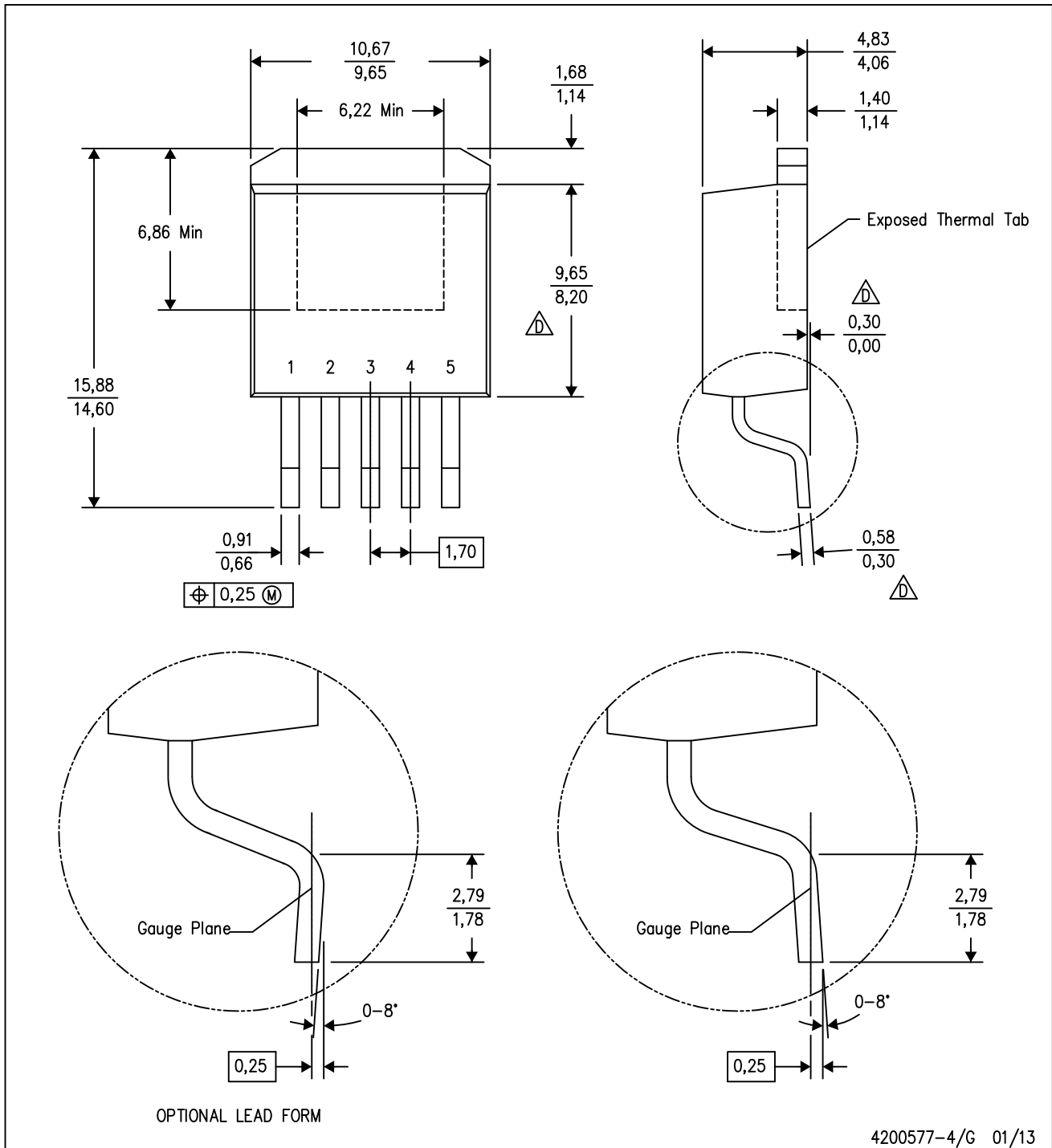

- NOTES:
- A. All linear dimensions are in millimeters.
  - B. This drawing is subject to change without notice.
  - C. Body dimensions do not include mold flash or protrusion. Mold flash or protrusion not to exceed 0.005 (0,13) per side.
- △ Falls within JEDEC TO-263 variation BA, except minimum lead thickness, maximum seating height, and minimum body length.

KTT (R-PSFM-G5)

PLASTIC FLANGE-MOUNT PACKAGE

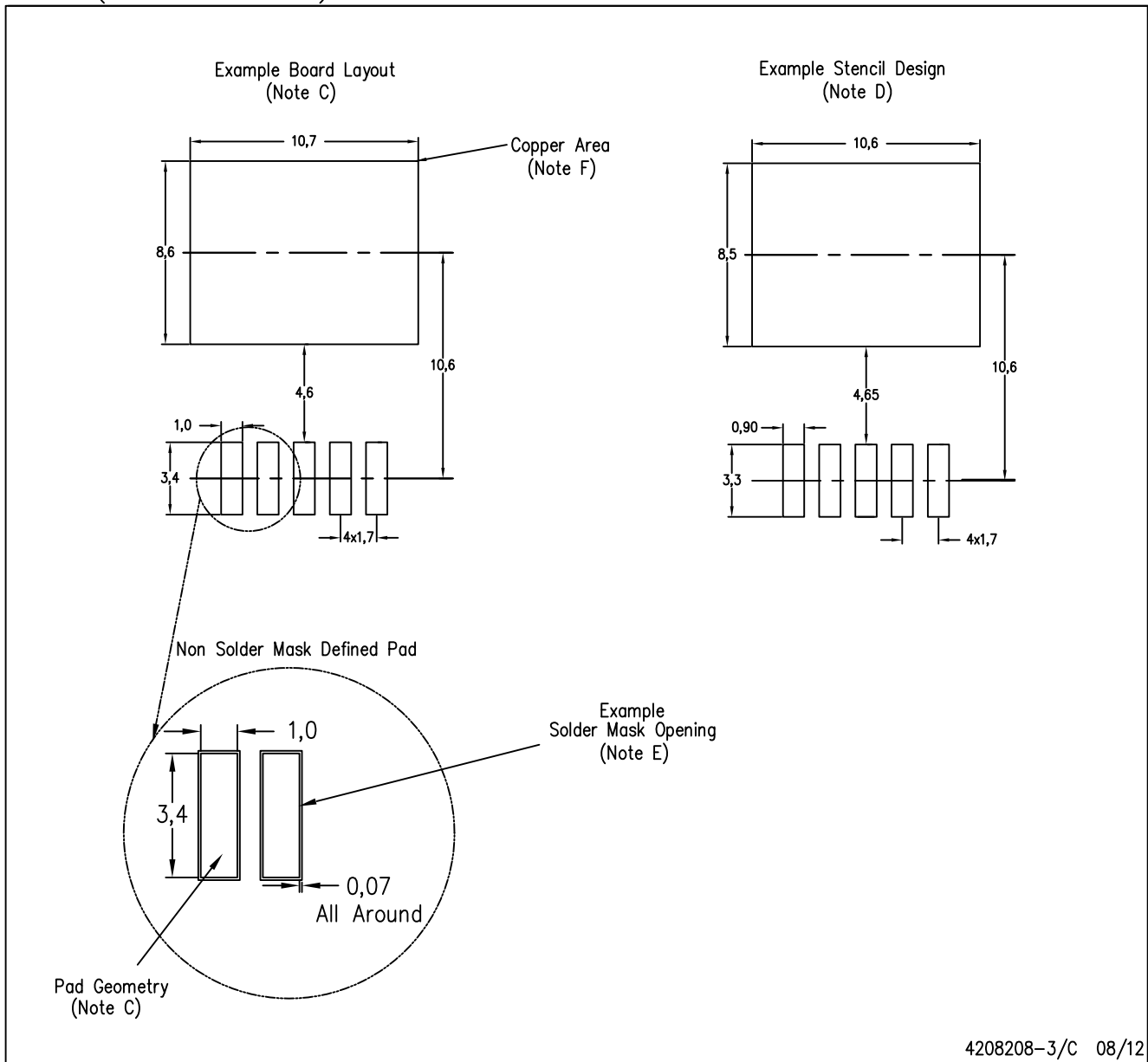

4208208-3/C 08/12

- NOTES:
- All linear dimensions are in millimeters.
  - This drawing is subject to change without notice.
  - Publication IPC-SM-782 is recommended for alternate designs.
  - Laser cutting apertures with trapezoidal walls and also rounding corners will offer better paste release. Customers should contact their board assembly site for stencil design recommendations. Refer to IPC-7525.
  - Customers should contact their board fabrication site for solder mask tolerances between and around signal pads.
  - This package is designed to be soldered to a thermal pad on the board. Refer to the Product Datasheet for specific thermal information, via requirements, and recommended thermal pad size. For thermal pad sizes larger than shown a solder mask defined pad is recommended in order to maintain the solderable pad geometry while increasing copper area.

# KC0005A



# PACKAGE OUTLINE

TO-220 - 16.51 mm max height

TO-220

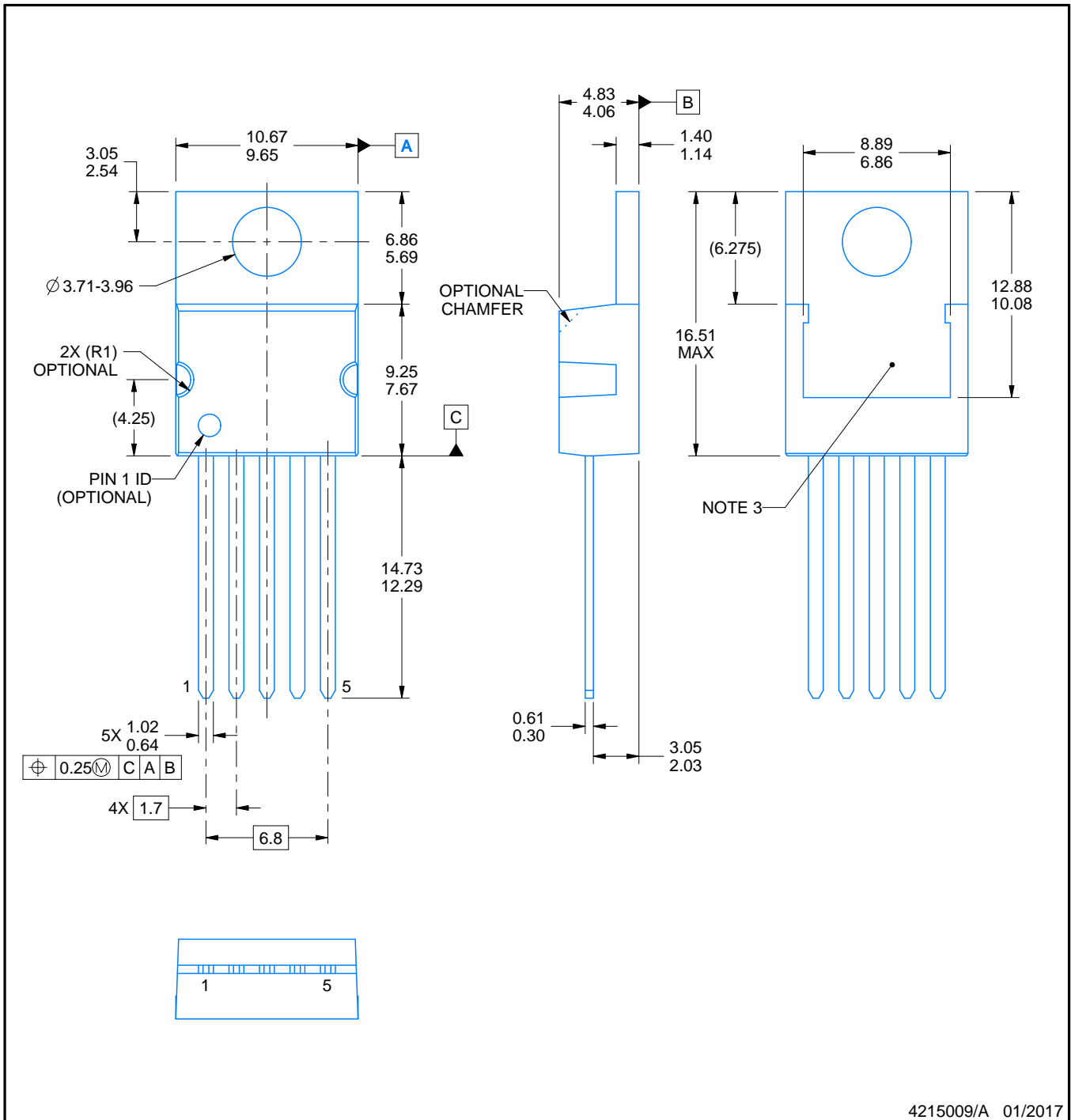

4215009/A 01/2017

**NOTES:**

1. All controlling linear dimensions are in inches. Dimensions in brackets are in millimeters. Any dimension in brackets or parenthesis are for reference only. Dimensioning and tolerancing per ASME Y14.5M.
2. This drawing is subject to change without notice.
3. Shape may vary per different assembly sites.

# EXAMPLE BOARD LAYOUT

KC0005A

TO-220 - 16.51 mm max height

TO-220



LAND PATTERN  
NON-SOLDER MASK DEFINED  
SCALE:12X

4215009/A 01/2017

## IMPORTANT NOTICE AND DISCLAIMER

TI PROVIDES TECHNICAL AND RELIABILITY DATA (INCLUDING DATA SHEETS), DESIGN RESOURCES (INCLUDING REFERENCE DESIGNS), APPLICATION OR OTHER DESIGN ADVICE, WEB TOOLS, SAFETY INFORMATION, AND OTHER RESOURCES "AS IS" AND WITH ALL FAULTS, AND DISCLAIMS ALL WARRANTIES, EXPRESS AND IMPLIED, INCLUDING WITHOUT LIMITATION ANY IMPLIED WARRANTIES OF MERCHANTABILITY, FITNESS FOR A PARTICULAR PURPOSE OR NON-INFRINGEMENT OF THIRD PARTY INTELLECTUAL PROPERTY RIGHTS.

These resources are intended for skilled developers designing with TI products. You are solely responsible for (1) selecting the appropriate TI products for your application, (2) designing, validating and testing your application, and (3) ensuring your application meets applicable standards, and any other safety, security, regulatory or other requirements.

These resources are subject to change without notice. TI grants you permission to use these resources only for development of an application that uses the TI products described in the resource. Other reproduction and display of these resources is prohibited. No license is granted to any other TI intellectual property right or to any third party intellectual property right. TI disclaims responsibility for, and you will fully indemnify TI and its representatives against, any claims, damages, costs, losses, and liabilities arising out of your use of these resources.

TI's products are provided subject to [TI's Terms of Sale](#) or other applicable terms available either on [ti.com](http://ti.com) or provided in conjunction with such TI products. TI's provision of these resources does not expand or otherwise alter TI's applicable warranties or warranty disclaimers for TI products.

TI objects to and rejects any additional or different terms you may have proposed.

Mailing Address: Texas Instruments, Post Office Box 655303, Dallas, Texas 75265  
Copyright © 2022, Texas Instruments Incorporated