

TPS81256 3W 高效升压转换器，采用 MicroSiP™ 封装

1 特性

- 运行频率为 4MHz 时，效率 91%
- 2.5V 至 5.5V 的宽输入电压范围
- $V_{OUT}=5.0V$, $V_{IN} \geq 3.3V$ 时, $I_{OUT} \geq 550mA$
- 5.0V 固定输出电压
- 总直流电压精度为 $\pm 2\%$
- 43 μA 电源电流
- 同类产品中最佳的线路和负载瞬态
- $V_{IN} \geq V_{OUT}$ 运行
- 低纹波轻负载脉冲频率调制 (PFM) 模式
- 关断期间的真正负载断开
- 热关断和过载保护
- 高度低于 1mm 的解决方案
- 总体解决方案尺寸 < 9mm²
- 9 引脚 MicroSiP 封装

2 应用

- 手机、智能电话、平板电脑
- 单声道和立体声 APA 应用
- USB-OTG、HDMI 应用
- USB 充电端口 (5V)

3 说明

TPS81256 器件是一个完整的 MicroSiP 直流/直流升压电源解决方案，适用于电池供电的便携式应用。封装中包括开关稳压器、电感器和输入/输出电容器。只需一个极小的额外输出电容器即可完成此设计。

TPS81256 是一款基于高频同步升压直流/直流转换器而构建的器件，经优化可适用于电池供电的便携式应用。

该直流/直流转换器可在 4MHz 的稳定开关频率下工作，可在轻负载电流时进入省电模式，以保持整个负载电流范围内的高效率。

PFM 模式可在轻负载工作时将电源电流降至 43 μA （典型值），从而延长电池使用寿命。TPS81256 适用于低功耗应用，在整个锂离子电池电压范围内支持 3W 以上的输出功率。关断模式下的输入电流低于 1 μA （典型值），最大程度地延长了电池寿命。

由于只需很少的外部组件，TPS81256 提供了一个小于 9mm² 的极小解决方案尺寸。此解决方案采用一个紧凑型 (2.6mm x 2.9mm) 且低厚度 (1.0mm) 的球状引脚栅格阵列 (BGA) 封装，此封装适合用于采用标准表面贴装设备的自动组装。

器件信息⁽¹⁾

器件型号	封装	封装尺寸 (标称值)
TPS81256	μ SIP (9)	2.925mm x 2.575mm

(1) 如需了解所有可用封装，请参阅数据表末尾的可订购产品附录。

典型应用

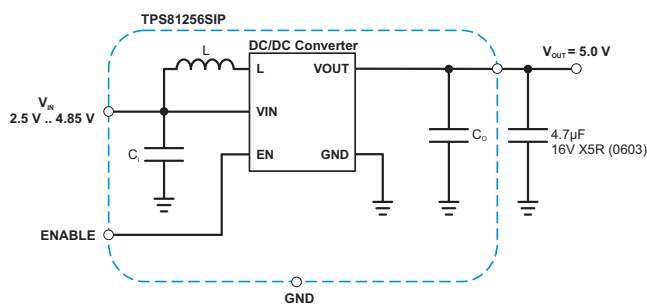

效率与负载电流间的关系

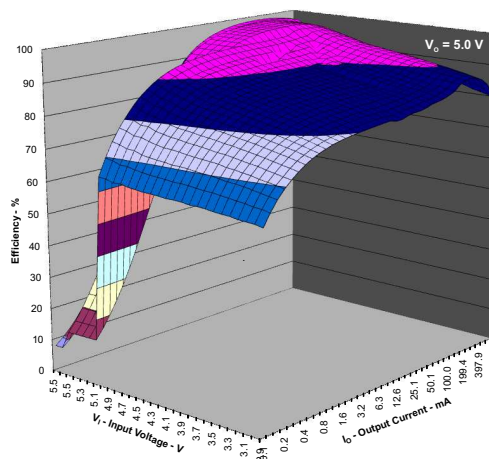

目录

1	特性	1	9	Application and Implementation	12
2	应用	1	9.1	Application Information.....	12
3	说明	1	9.2	Typical Application	12
4	修订历史记录	2	9.3	System Examples	15
5	Device Options	3	10	Power Supply Recommendations	17
6	Pin Configuration and Functions	3	11	Layout	17
7	Specifications	4	11.1	Layout Guidelines	17
7.1	Absolute Maximum Ratings	4	11.2	Layout Example	17
7.2	ESD Ratings	4	11.3	Surface Mount Information	18
7.3	Recommended Operating Conditions.....	4	11.4	Thermal and Reliability Information	18
7.4	Thermal Information	5	12	器件和文档支持	20
7.5	Electrical Characteristics.....	5	12.1	器件支持	20
7.6	Typical Characteristics	6	12.2	社区资源	20
8	Detailed Description	9	12.3	商标	20
8.1	Overview	9	12.4	静电放电警告	20
8.2	Functional Block Diagram	9	12.5	Glossary	20
8.3	Feature Description.....	9	13	机械、封装和可订购信息	21
8.4	Device Functional Modes.....	11			

4 修订历史记录

注：之前版本的页码可能与当前版本有所不同。

Changes from Revision C (February 2016) to Revision D	Page
• 更新了封装图	22

Changes from Revision B (February 2015) to Revision C	Page
• 调换了 D & E 尺寸以与“机械数据”制图相匹配；并将说明中的“8 凸点”改为“9 凸点”。	21
• 已添加 社区资源 部分	21

Changes from Revision A (August 2013) to Revision B	Page
• 添加了器件信息和 ESD 额定值表、特性 说明 部分、器件功能模式、应用和实施部分、系统示例、电源建议部分、器件和文档支持部分以及机械、封装和可订购信息部分。	1
• Changed the pinout drawing to match the device orientation shown on the MECHANICAL DATA drawing.	3
• 已更改 更改了 SIP 封装“俯视图”图像方向，使“YML LSB”符号和引脚 A1 正确匹配。	21

Changes from Original (June 2012) to Revision A	Page
• Added animated performance characteristics table	6
• Deleted MLCC capacitor B1 life documentation.....	19

5 Device Options

PART NUMBER	OUTPUT VOLTAGE	PACKAGE MARKING CHIP CODE
TPS81256	5.0V	TT

6 Pin Configuration and Functions

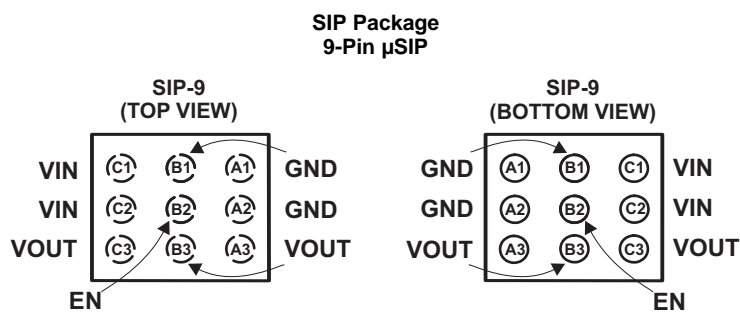

Pin Functions

PIN		I/O	DESCRIPTION
NAME	NO.		
EN	B2	I	This is the enable pin of the device. Connecting this pin to ground forces the device into shutdown mode. Pulling this pin high enables the device. This pin must not be left floating and must be terminated.
GND	A1, A2, B1		Ground pin.
VIN	C1, C2	I	Power supply input.
VOUT	A3, B3, C3	O	Boost converter output.

7 Specifications

7.1 Absolute Maximum Ratings

over operating free-air temperature range (unless otherwise noted) ⁽¹⁾

		MIN	MAX	UNIT
Input voltage	Voltage at VIN ⁽²⁾ , VOUT ⁽²⁾ , EN ⁽²⁾	−0.3	6	V
Input current	Continuous average current into VIN ⁽³⁾		1.05	A
	Pulsed current into VIN ⁽⁴⁾		1.3	A
Power dissipation		Internally limited		
Operating temperature, T _A ⁽³⁾⁽⁴⁾⁽⁵⁾		−40	85	°C
Operating virtual junction temperature, T _J		−40	150	°C
Storage temperature, T _{stg}		−55	125	°C

- (1) Stresses beyond those listed under *Absolute Maximum Ratings* may cause permanent damage to the device. These are stress ratings only, which do not imply functional operation of the device at these or any other conditions beyond those indicated under *Recommended Operating Conditions*. Exposure to absolute-maximum-rated conditions for extended periods may affect device reliability.
- (2) All voltages are with respect to network ground terminal.
- (3) Limit the junction and the (top side) inductor case temperature to 110°C, limit the (top side) capacitor case temperature to 85°C for 2000h operation at maximum output power. Contact TI for more details on lifetime estimation.
- (4) Limit the (top side) inductor case temperature to 140°C and the (top side) capacitor temperature to 115°C for 100h operation. Contact TI for more details on lifetime estimation.
- (5) In applications where high power dissipation and/or poor package thermal resistance is present, the maximum ambient temperature may have to be derated. Maximum ambient temperature (T_{A(max)}) is dependent on the maximum operating junction temperature (T_{J(max)}), the maximum power dissipation of the device in the application (P_{D(max)}), and the junction-to-ambient thermal resistance of the part/package in the application (θ_{JA}), as given by the following equation: T_{A(max)} = T_{J(max)} − (θ_{JA} × P_{D(max)}). To achieve optimum performance, it is recommended to operate the device with a maximum junction temperature of 125°C, a maximum inductor case temperature of 125°C and a maximum capacitor case temperature of 85°C.

7.2 ESD Ratings

			VALUE	UNIT
V _(ESD)	Electrostatic discharge	Human body model (HBM), per ANSI/ESDA/JEDEC JS-001, all pins ⁽¹⁾	±2000	V
		Charged device model (CDM), per JEDEC specification JESD22-C101, all pins ⁽²⁾	±1000	
		Machine Model - (MM)	±200	

- (1) JEDEC document JEP155 states that 500-V HBM allows safe manufacturing with a standard ESD control process.
- (2) JEDEC document JEP157 states that 250-V CDM allows safe manufacturing with a standard ESD control process.

7.3 Recommended Operating Conditions

over operating free-air temperature range (unless otherwise noted)

		MIN	NOM	MAX	UNIT
V _I	Input voltage range	2.5		5.5	V
R _L	Minimum resistive load for start-up (V _I ≤ 4.8V)	65			Ω
C _{EXT}	Output capacitance	2		30	μF
T _A	Ambient temperature	−40		85	°C
T _J	Operating junction temperature	−40		125	°C
T _{CASE_IND}	Operating inductor case temperature			125	°C
T _{CASE_CAP}	Operating capacitor case temperature			85	°C

7.4 Thermal Information

THERMAL METRIC ⁽¹⁾		TPS81256		UNIT
		μSIP (SIP) – 9 PINS		
R _{θJA}	Junction-to-ambient thermal resistance	62		°C/W
ψ _{JB}	Junction-to-board characterization parameter	31		
ψ _{JT}	Junction-to-case (top) thermal resistance	–		

(1) Thermal data have been simulated with high-K board (per JEDEC standard).

7.5 Electrical Characteristics

Minimum and maximum values are at V_{IN} = 2.5V to 5.5V, V_{OUT} = 5.0V (or V_{IN}, whichever is higher), EN = 1.8V, T_A = –40°C to 85°C; Circuit of Parameter Measurement Information section (unless otherwise noted). Typical values are at V_{IN} = 3.6V, V_{OUT} = 5.0V, EN = 1.8V, T_A = 25°C (unless otherwise noted).

PARAMETER		TEST CONDITIONS	MIN	TYP	MAX	UNIT
SUPPLY CURRENT						
I _Q	Operating quiescent current into V _{IN} ⁽¹⁾	I _{OUT} = 0mA, V _{OUT} = 5.0V, V _{IN} = 3.6V EN = V _{IN} Device not switching		30	50	μA
	Operating quiescent current into V _{OUT} ⁽¹⁾			7	20	μA
I _{SD}	Shutdown current ⁽¹⁾	EN = GND		0.85	5.0	μA
V _{UVLO}	Under-voltage lockout threshold	Falling		2.0	2.1	V
		Hysteresis		0.1		V
ENABLE						
V _{IL}	Low-level input voltage				0.4	V
V _{IH}	High-level input voltage		1.0			V
I _{lkg}	Input leakage current	Input connected to GND or V _{IN}			0.5	μA
OUTPUT						
V _{OUT}	Regulated DC output voltage	2.5V ≤ V _{IN} ≤ 4.85V, I _{OUT} = 0mA PWM operation. Open Loop	4.92	5	5.08	V
		3.3V ≤ V _{IN} ≤ 4.85V, 0mA ≤ I _{OUT} ≤ 550mA PFM/PWM operation	4.85	5	5.2	V
		2.9V ≤ V _{IN} ≤ 4.85V, 0mA ≤ I _{OUT} ≤ 450mA PFM/PWM operation	4.85	5	5.2	V
ΔV _{OUT}	Power-save mode output ripple voltage	PFM operation, I _{OUT} = 1mA		35		mVpk
	PWM mode output ripple voltage	PWM operation, I _{OUT} = 200mA		8		mVpk
POWER SWITCH						
r _{DS(on)}	Input-to-output On-resistance	V _I = 5.25 V. Device not switching		320		mΩ
I _{lkg}	Reverse leakage current into V _{OUT} ⁽¹⁾	EN = GND			5	μA
I _{LIM}	Average input current limit	EN = V _{IN} , V _{IN} = 3.3V		1180		mA
	Overtemperature protection			140		°C
	Overtemperature hysteresis			20		°C
OSCILLATOR						
f _{OSC}	Oscillator frequency	V _{IN} = 3.6V, V _{OUT} = 5.0V, I _{OUT} = 500mA		4		MHz
TIMING						
	Start-up time	I _{OUT} = 0mA Time from active EN to start switching		70		μs
		I _{OUT} = 0mA Time from active EN to V _{OUT}		400		μs

(1) Maximum values can vary over lifetime due to intrinsic capacitor ageing effects. For more details, refer to [Thermal and Reliability Information](#) section.

7.6 Typical Characteristics

Table 1. Table of Graphs

			FIGURE
η	Efficiency	vs Output current	Figure 1, Figure 3
		vs Input voltage	Figure 2
V_O	DC output voltage	vs Output current	Figure 4, Figure 5, Figure 6
		vs Input voltage	Figure 7
I_O	Maximum output current	vs Input voltage	Figure 8
ΔV_O	Peak-to-peak output ripple voltage	vs Output current	Figure 8
I_{CC}	Supply current	vs Input voltage	Figure 10
I_{LIM}	Input current	vs Output current	Figure 11

Table 2. Table of Animated Performance Characteristics

		VIDEO
AC Load Response	vs. Input Voltage	Video 1
Load Transient Response (10mA to 400mA)	vs. Input Voltage	Video 2
Load Transient Response (to 400mA)	vs. Base Load Current ($2.9V_{IN}$)	Video 3
	vs. Base Load Current ($3.6V_{IN}$)	Video 4
	vs. Base Load Current ($4.2V_{IN}$)	Video 5
Start-Up Response	vs. Delay to Load Current ($2.9V_{IN}$)	Video 6
	vs. Delay to Load Current ($3.6V_{IN}$)	Video 7
	vs. Delay to Load Current ($4.2V_{IN}$)	Video 8
Start-Up Response (200mA I_{OUT})	vs. Input Voltage	Video 9
Overload Response	vs. Input Voltage	Video 10

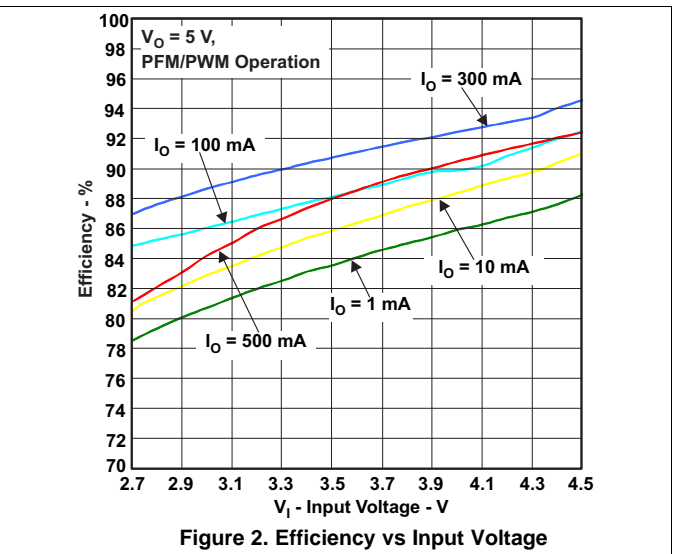
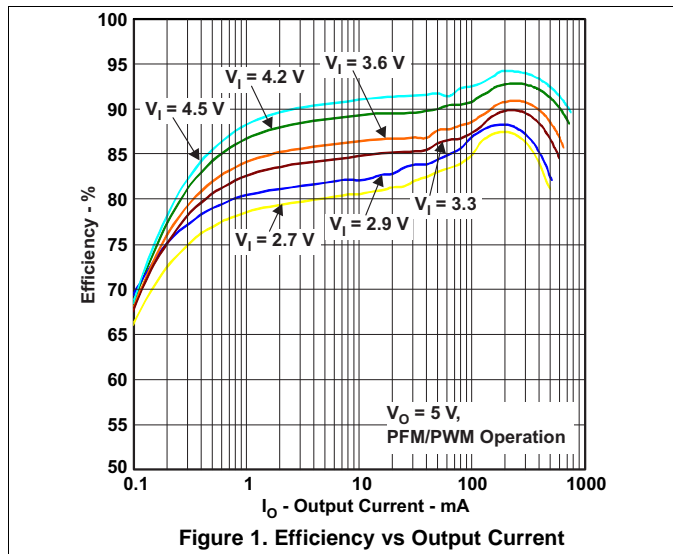

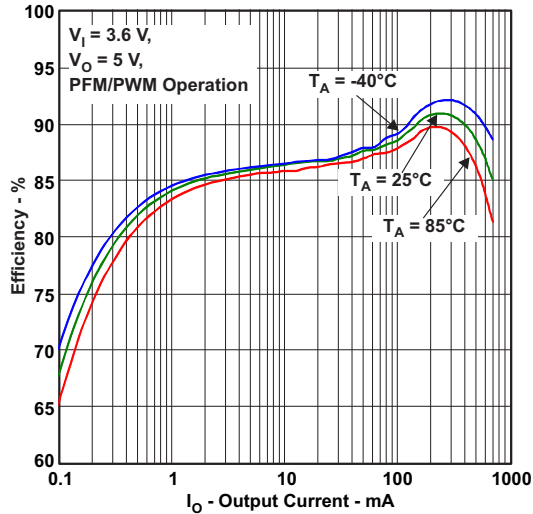

Figure 3. Efficiency vs Output Current

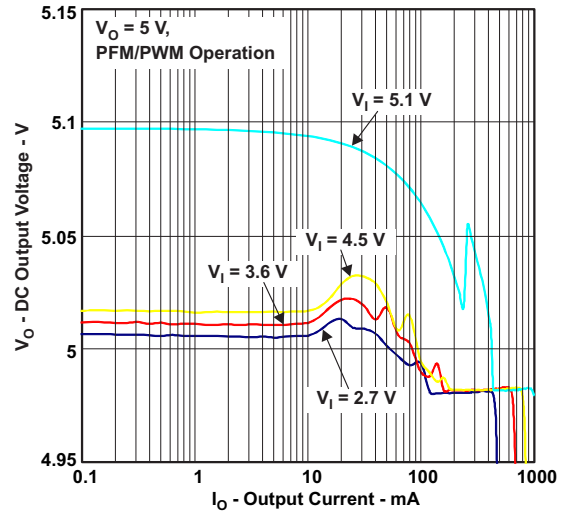

Figure 4. DC Output Voltage vs Output Current

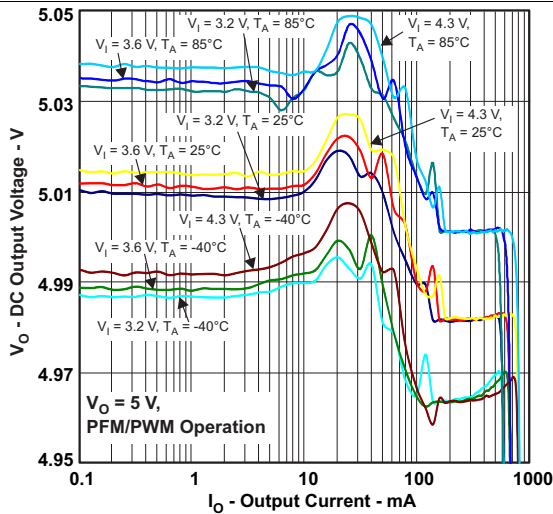

Figure 5. DC Output Voltage vs Output Current

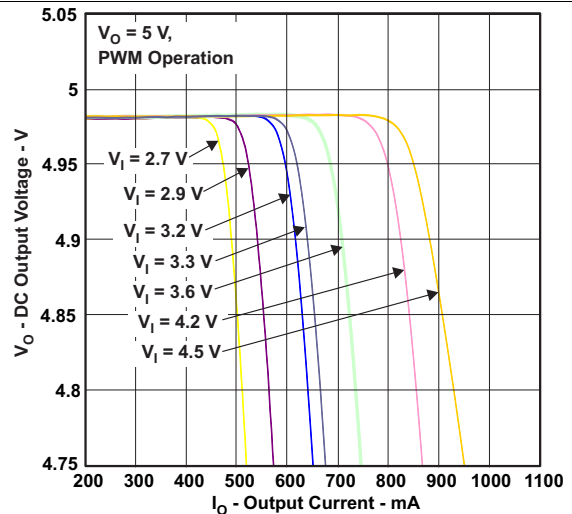

Figure 6. DC Output Voltage vs Output Current

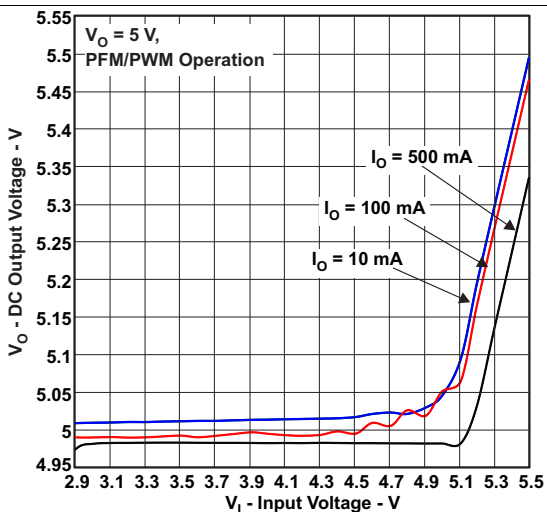

Figure 7. DC Output Voltage vs Input Voltage

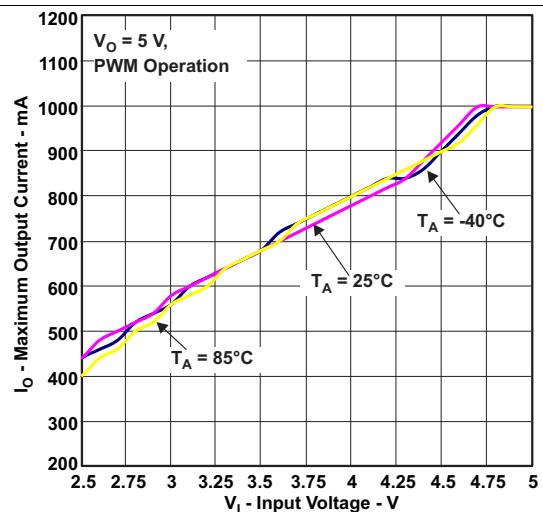

Figure 8. Maximum Output Current vs Input Voltage

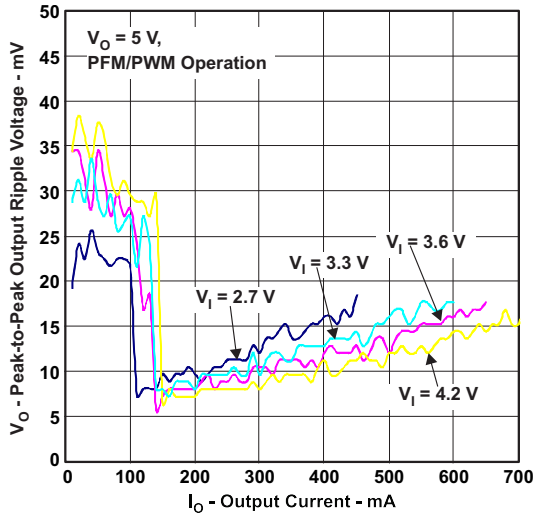

Figure 9. Peak-To-Peak Output Ripple Voltage vs Output Current

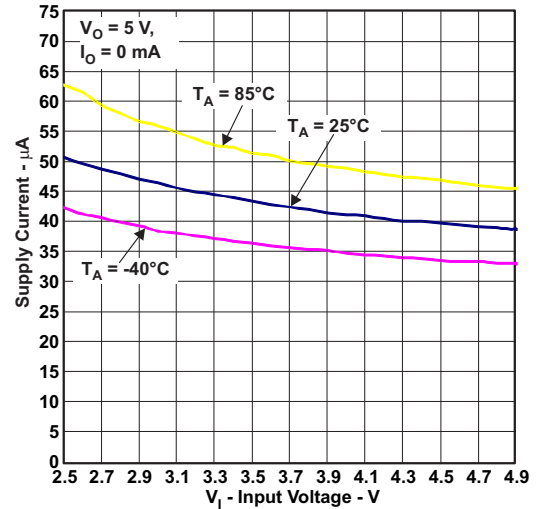

Figure 10. Supply Current vs Input Voltage

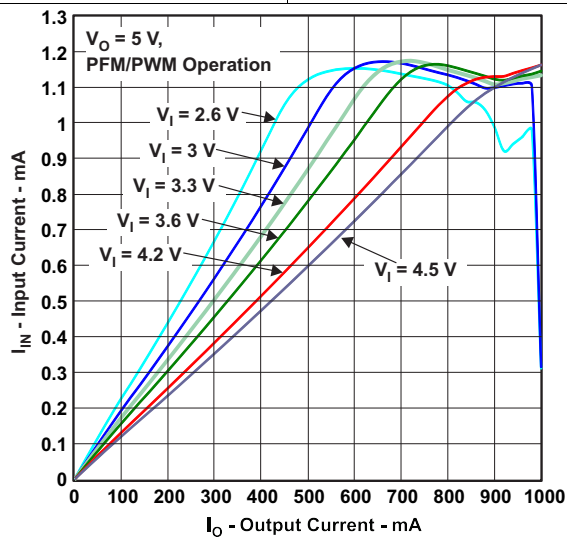

Figure 11. Input Current vs Output Current

8 Detailed Description

8.1 Overview

The TPS81256 is a stand-alone, synchronous, step-up converter module. The converter operates at a quasi-constant 4-MHz frequency pulse width modulation (PWM) at moderate to heavy load currents. At light load currents, the TPS81256 converter operates in power-save mode with pulse frequency modulation (PFM).

8.2 Functional Block Diagram

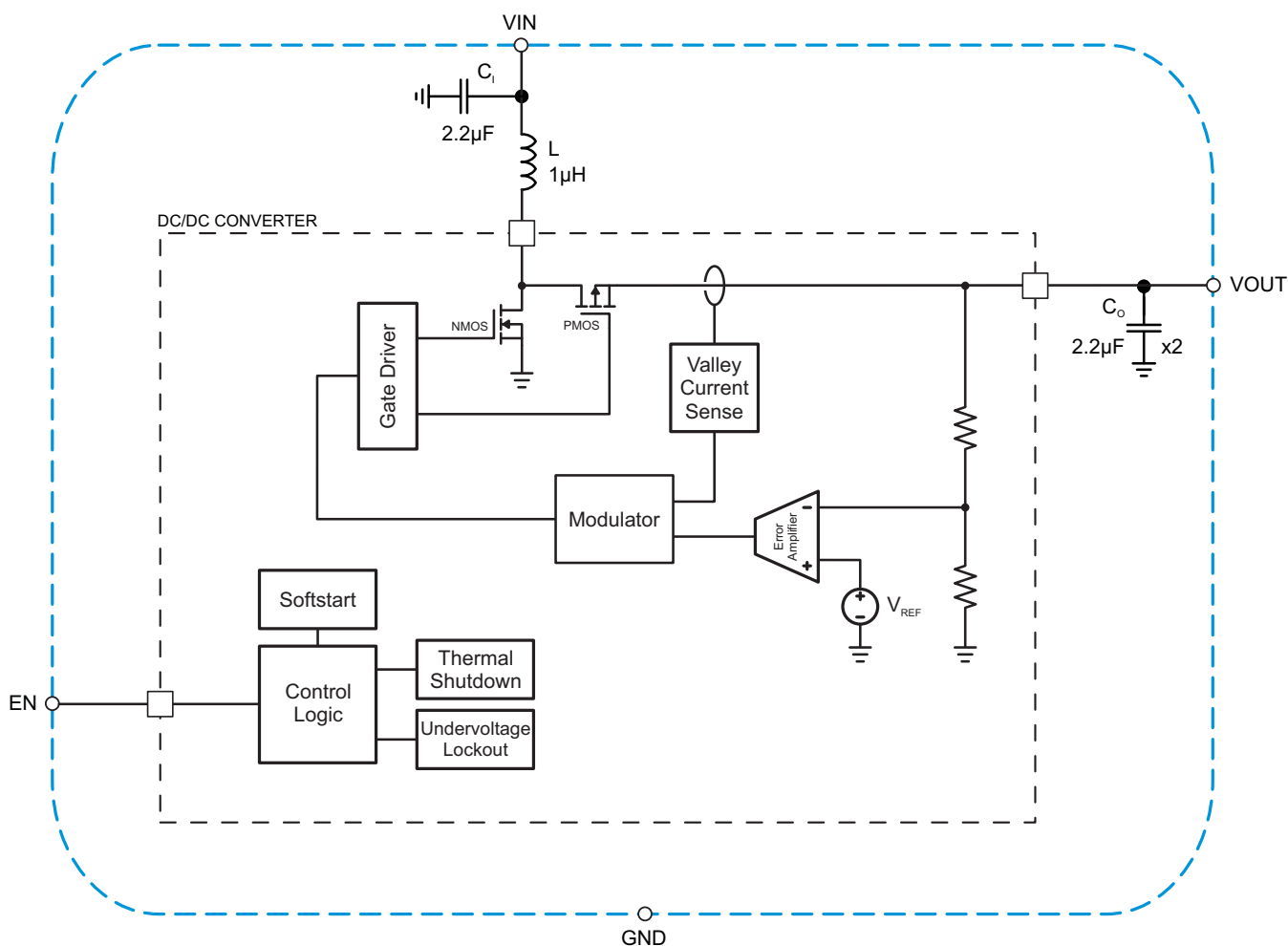

8.3 Feature Description

8.3.1 Operation

During PWM operation, the converter uses a novel quasi-constant on-time valley current mode control scheme to achieve excellent line/load regulation and allows the use of a small ceramic inductor and capacitors. Based on the V_{IN}/V_{OUT} ratio, a simple circuit predicts the required on-time.

At the beginning of the switching cycle, the low-side N-MOS switch is turned-on and the inductor current ramps up to a peak current that is defined by the on-time and the inductance. In the second phase, once the on-timer has expired, the rectifier is turned-on and the inductor current decays to a preset valley current threshold. Finally, the switching cycle repeats by setting the on timer again and activating the low-side N-MOS switch.

Feature Description (continued)

In general, a dc/dc step-up converter can only operate in "true" boost mode, i.e. the output "boosted" by a certain amount above the input voltage. The TPS81256 device operates differently as it can smoothly transition in and out of zero duty cycle operation. Therefore the output can be kept as close as possible to its regulation limits even though the converter is subject to an input voltage that tends to be excessive. In this operation mode, the output current capability of the regulator is limited to ca. 150mA. Refer to the typical characteristics section (DC Output Voltage vs. Input Voltage) for further details.

The current mode architecture with adaptive slope compensation provides excellent transient load response while requiring only one external tiny capacitor for output filtering and loop stability purposes. Internal soft-start and loop compensation simplifies the application design process.

8.3.2 Power-Save Mode

The TPS81256 integrates a power-save mode to improve efficiency at light load. In power-save mode the converter only operates when the output voltage trips below a set threshold voltage.

It ramps up the output voltage with several pulses and goes into power save mode when the output voltage exceeds the set threshold voltage.

PFM mode is exited and the PWM mode entered in case the output current can no longer be supported in PFM mode.

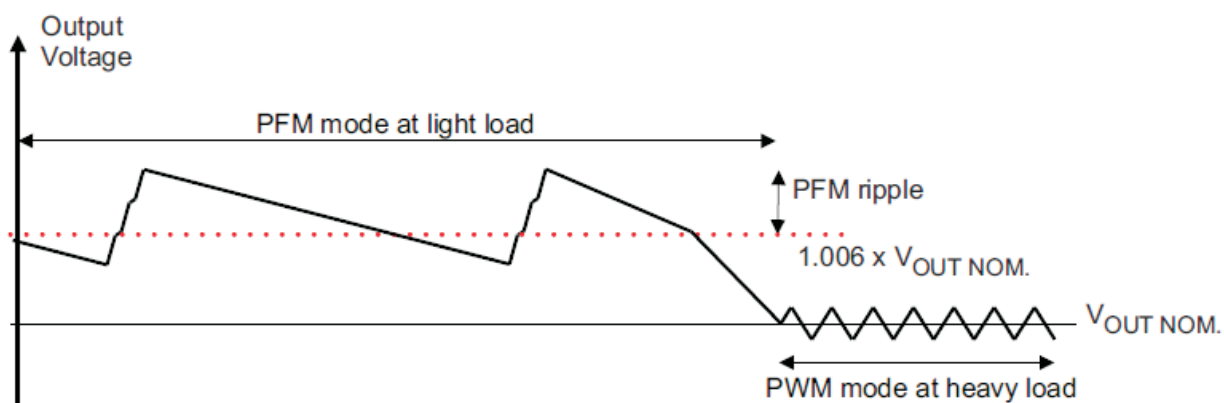

Figure 12. Power-Save Example

8.3.3 Current Limit Operation, Maximum Output Current

The TPS81256 directly and accurately controls the average input current through intelligent adjustment of the valley current limit. The current limit circuit employs a valley current sensing scheme. Current limit detection occurs during the off-time by sensing of the voltage drop across the synchronous rectifier.

The output voltage is reduced as the power stage of the device operates in a constant current mode. The maximum continuous output current ($I_{OUT(CL)}$), before entering current limit (CL) operation, can be defined by Equation 1.

$$I_{OUT(DC)} = I_{IN(CL)} \cdot \frac{V_{OUT}}{V_{IN}} \cdot \eta \quad (1)$$

The output current, $I_{OUT(DC)}$, is the average of the rectifier ripple current waveform. When the load current is increased such that the lower peak is above the current limit threshold, the off-time is increased to allow the current to decrease to this threshold before the next on-time begins (so called frequency fold-back mechanism). When the current limit is reached the output voltage decreases during further load increase.

8.4 Device Functional Modes

8.4.1 Softstart, Enable

The TPS81256 device starts operation when EN is set high and starts up with the soft-start sequence. For proper operation, the EN pin must be terminated and must not be left floating.

The TPS81256 device has an internal softstart circuit that limits the inrush current during start-up. The first step in the start-up cycle is the pre-charge phase. During pre-charge, the rectifying switch is turned on until the output capacitor is charged to a value close to the input voltage. The rectifying switch is current limited (approx. 200mA) during this phase. This mechanism is used to limit the output current under short-circuit condition.

Once the output capacitor has been biased to the input voltage, the converter starts switching. The soft-start system progressively increases the on-time as a function of the input-to-output voltage ratio. As soon as the output voltage is reached, the regulation loop takes control and full current operation is permitted.

Pulling the EN pin low forces the device in shutdown, with a shutdown current of typically 1 μ A. In this mode, true load disconnect between the battery and load prevents current flow from V_{IN} to V_{OUT} , as well as reverse flow from V_{OUT} to V_{IN} .

8.4.2 Load Disconnect and Reverse Current Protection

Regular boost converters do not disconnect the load from the input supply and therefore a connected battery will be discharge during shutdown. The advantage of TPS81256 is that this converter is disconnecting the output from the input of the power supply when it is disabled (so called true shutdown mode). In case of a connected battery it prevents it from being discharge during shutdown of the converter.

8.4.3 Undervoltage Lockout

The under voltage lockout circuit prevents the device from malfunctioning at low input voltages and the battery from excessive discharge. It disables the output stage of the converter once the falling V_{IN} trips the under-voltage lockout threshold V_{UVLO} which is typically 2.0V. The device starts operation once the rising V_{IN} trips V_{UVLO} threshold plus its hysteresis of 100 mV at typically 2.1V.

8.4.4 Thermal Regulation

The TPS81256 device contains a thermal regulation loop that monitors the die temperature during the pre-charge phase. If the die temperature rises to high values of about 110°C, the device automatically reduces the current to prevent the die temperature from increasing further. Once the die temperature drops about 10°C below the threshold, the device will automatically increase the current to the target value. This function also reduces the current during a short-circuit condition.

8.4.5 Thermal Shutdown

As soon as the junction temperature, T_J , exceeds 140°C (typically) the device goes into thermal shutdown. In this mode, the high-side and low-side MOSFETs are turned-off. When the junction temperature falls below the thermal shutdown minus its hysteresis, the device continuous the operation.

9 Application and Implementation

NOTE

Information in the following applications sections is not part of the TI component specification, and TI does not warrant its accuracy or completeness. TI's customers are responsible for determining suitability of components for their purposes. Customers should validate and test their design implementation to confirm system functionality.

9.1 Application Information

The TPS81256 device is a complete MicroSiP™ DC/DC step-up power solution intended for battery-powered portable applications.

9.2 Typical Application

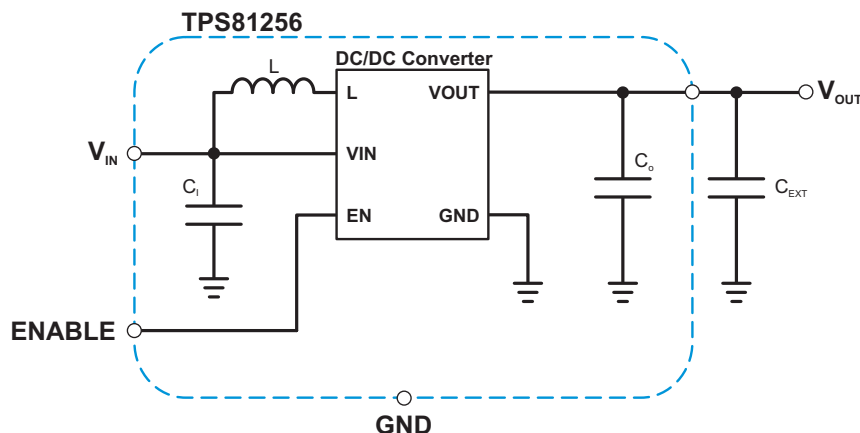

Figure 13. 5-V Power Supply

9.2.1 Design Requirements

The following design guidelines provide a component selection process for the typical application circuit shown to operate the device within the [Recommended Operating Conditions](#).

9.2.2 Detailed Design Procedure

9.2.2.1 Output Capacitor Selection C_{EXT}

Because of the pulsating output current nature of the boost converter, a low ESR output capacitor is required to maintain control loop stability, to enhance the converter's transient response and to reduce the output voltage ripple. For the output capacitor, it is recommended to use small ceramic capacitors placed as close as possible to the VOUT and GND pins of the IC. The minimum capacitance is 2μF.

To get an estimate of the steady ripple due to charging and discharging the output capacitance, [Equation 2](#) can be used.

$$\Delta V = \frac{I_{OUT} \cdot (V_{OUT} - V_{IN})}{C \cdot V_{OUT} \cdot f} \quad (2)$$

Where f is the switching frequency which is 4MHz (typically.) and C is the effective output capacitance. Notice the TPS81256 device already incorporates ca. 1.2μF effective output capacitance.

In practice, the total ripple is larger due to the ESR of the output capacitor. This additional component of the ripple can be calculated using [Equation 3](#):

$$V_{ESR} = I_{OUT} \cdot R_{ESR} \quad (3)$$

Typical Application (continued)

An MLCC capacitor with twice the value of the calculated minimum should be used due to DC bias effects. The output capacitor requires either an X7R or X5R dielectric. Y5V and Z5U dielectric capacitors, aside from their wide variation in capacitance over temperature, become resistive at high frequencies. There are no additional requirements regarding minimum ESR. Larger capacitors cause lower output voltage ripple as well as lower output voltage drop during load transients but the total output capacitance value should not exceed ca. 30 μ F.

DC bias effect: high cap. ceramic capacitors exhibit DC bias effects, which have a strong influence on the device's effective capacitance. Therefore the right capacitor value has to be chosen very carefully. Package size and voltage rating in combination with material are responsible for differences between the rated capacitor value and its effective capacitance. For instance, a 4.7 μ F X5R 16V 0603 MLCC capacitor would typically show an effective capacitance of less than 2.5 μ F (under 5V bias condition, high temperature and ageing effects).

Because the damping factor in the output path is directly related to several resistive parameters (e.g. inductor DCR, power-stage $r_{DS(on)}$, PWB DC resistance, load switches $r_{DS(on)}$...) that are temperature dependant, the converter small and large signal behavior must be checked over the input voltage range, load current range and temperature range.

The easiest sanity test is to evaluate, directly at the converter's output, the following aspects:

- PFM/PWM efficiency
- PFM/PWM and PWM load transient response

During the recovery time from a load transient, the output voltage can be monitored for settling time, overshoot or ringing that helps judge the converter's stability. Without any ringing, the loop has usually more than 45° of phase margin.

Table 3. Recommended Capacitor C_{EXT}

REFERENCE	DESCRIPTION	PART NUMBER, MANUFACTURER ⁽¹⁾
C_{EXT}	4.7 μ F, 16V, 0603, X5R ceramic	GRM188R61C475KAAJ, muRata

(1) See [Third-Party Products Disclaimer](#)

9.2.2.2 Input Capacitor Selection

In a dc/dc boost converter, since the input current is continuous, only minimum input capacitance is required. The TPS81256 device integrates a low ESR decoupling capacitor to prevent large voltage transients that can cause misbehavior of the device or interference in other circuits in the system.

For most applications, the input capacitor that is integrated into the TPS81256 should be sufficient. If the application exhibits a noisy or erratic switching frequency, experiment with additional input capacitance to find a remedy. Multilayer ceramic capacitors are an excellent choice for input decoupling of the step-up converter as they have extremely low ESR and are available in small footprints. Additional input capacitors should be located as close as possible to the device.

The TPS81256 uses a tiny ceramic input capacitor. When a ceramic capacitor is combined with trace or cable inductance, such as from a wall adapter, a load step at the output can induce ringing at the VIN pin. This ringing can couple to the output and be mistaken as loop instability or can even damage the part. In this circumstance, additional "bulk" capacitance, such as electrolytic or tantalum, should be placed between the input of the converter and the power source lead to reduce ringing that can occur between the inductance of the power source leads and C_I .

9.2.3 Application Curves

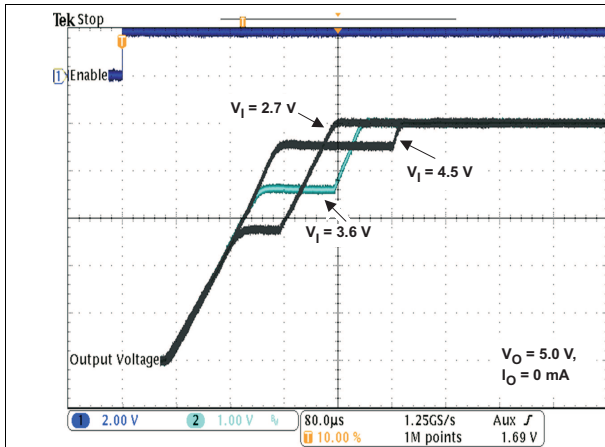

Figure 14. Start-Up

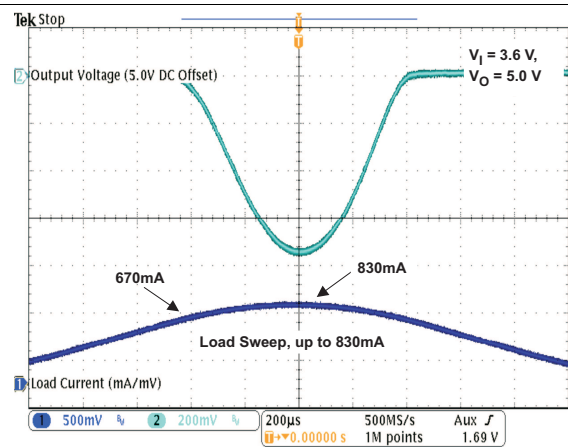

Figure 15. Overload Recovery Response

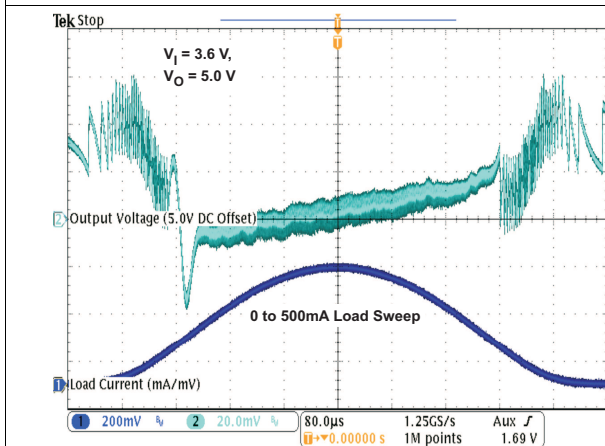

Figure 16. AC Load Transient

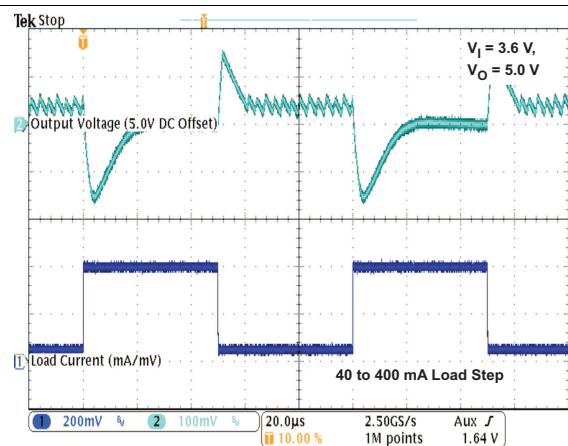

Figure 17. Load Transient Response In PFM/PWM Operation

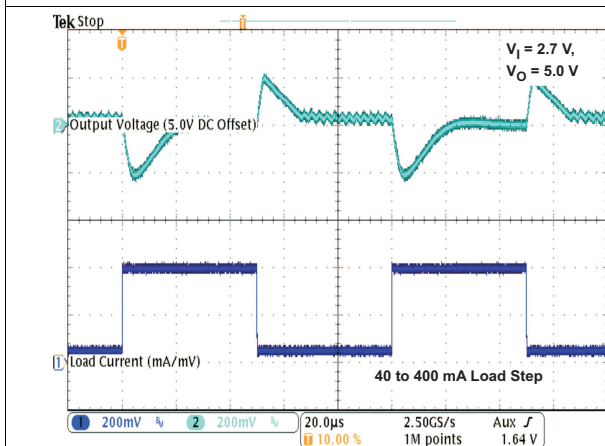

Figure 18. Load Transient Response In PFM/PWM Operation

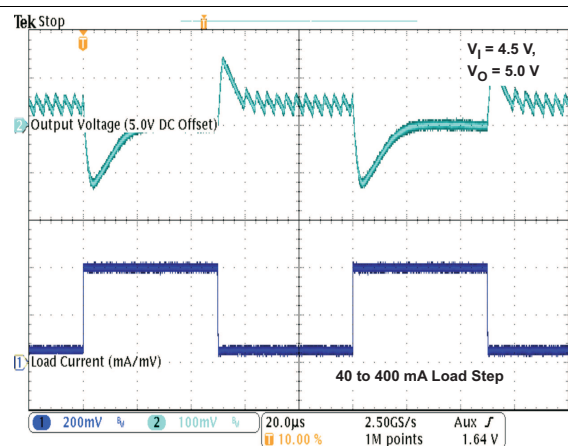

Figure 19. Load Transient Response In PFM/PWM Operation

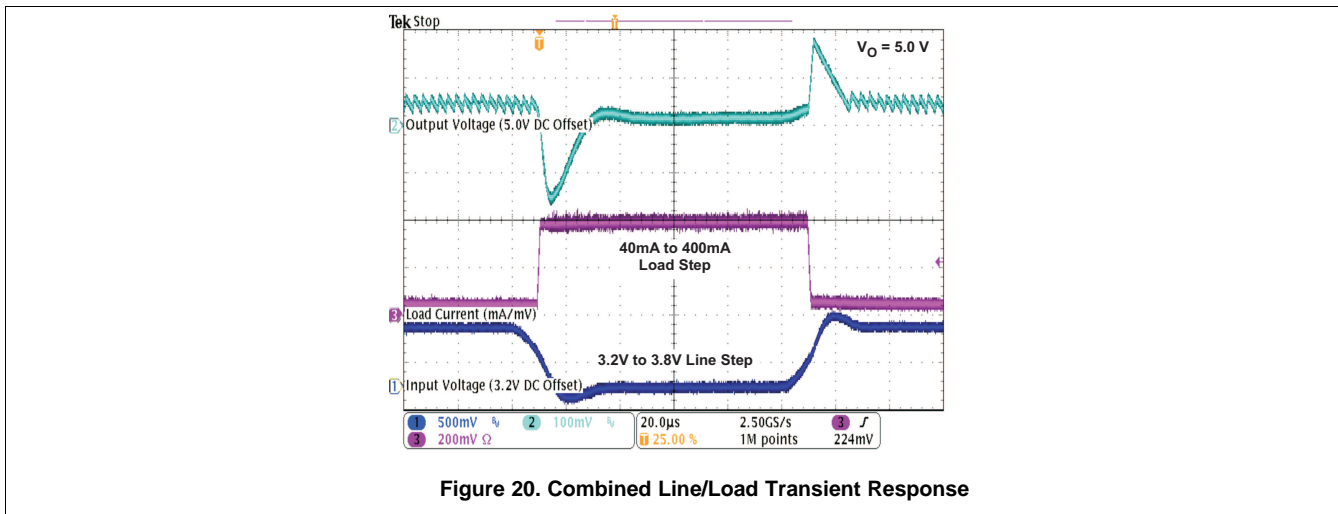
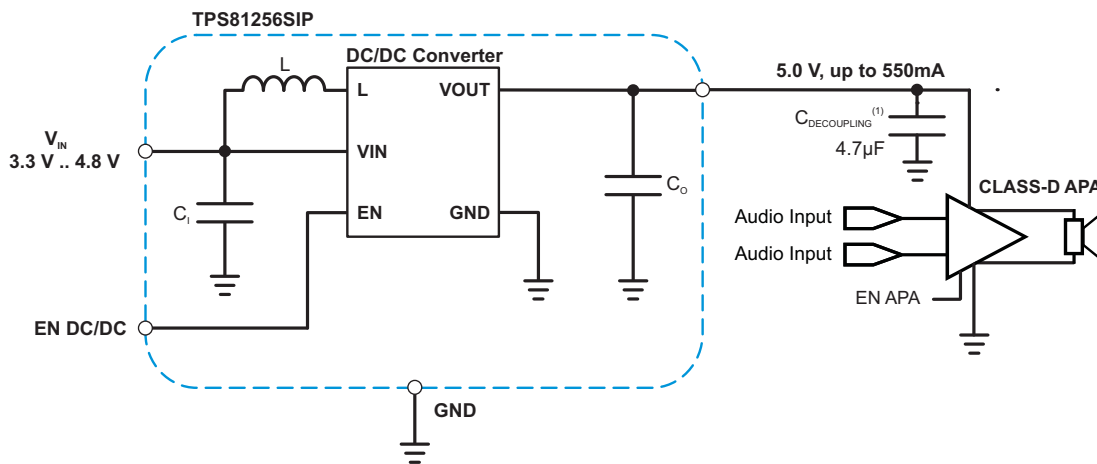

Figure 20. Combined Line/Load Transient Response

9.3 System Examples



⁽¹⁾ The capacitor is not only required to decouple the audio power amplifier, but is also required to stable operation of the SMPS converter. The SMPS converter should be located in the close vicinity of the audio power amplifier.

Figure 21. "Boosted" Audio Power Supply

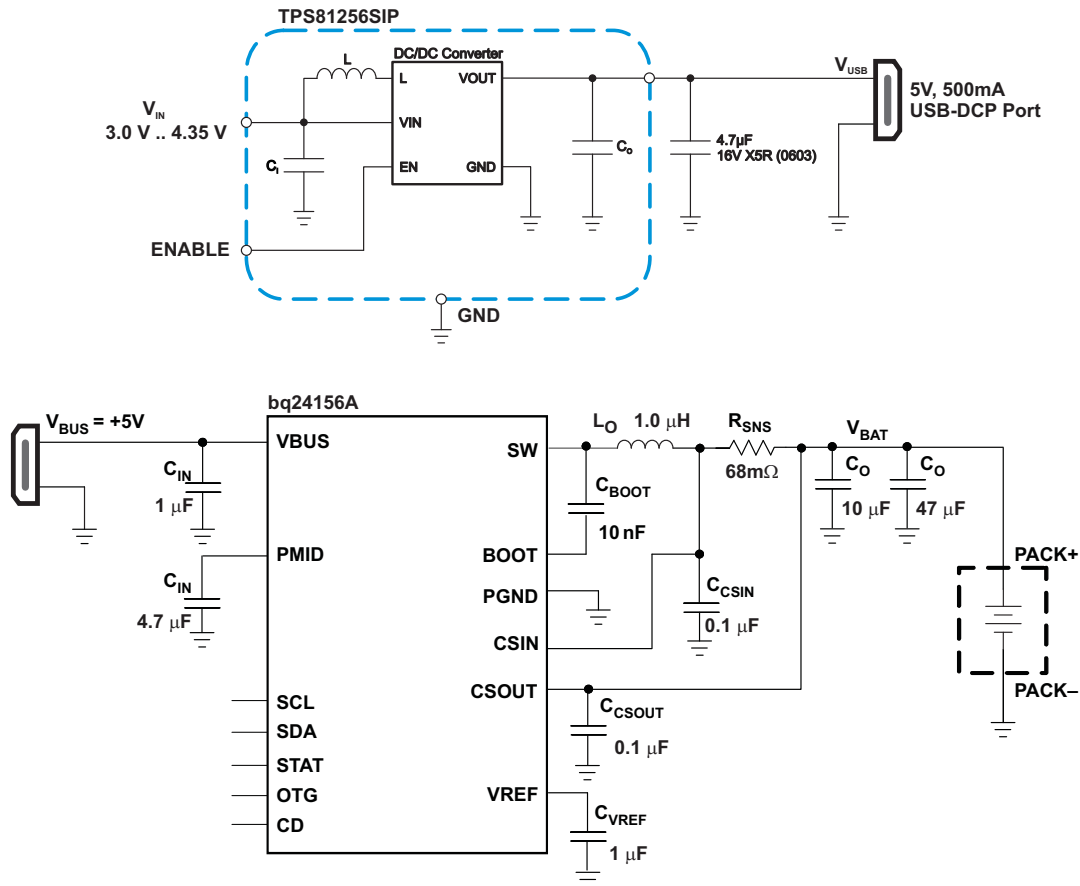
System Examples (continued)

Figure 22. Battery Powered USB-DCP Power Supply

10 Power Supply Recommendations

The TPS81256 has no special requirements for its input power supply. The input power supply's output current needs to be rated according to the supply voltage, output voltage and output current of the TPS81256

11 Layout

11.1 Layout Guidelines

In making the pad size for the μ SiP LGA balls, it is recommended that the layout use non-solder-mask defined (NSMD) land. With this method, the solder mask opening is made larger than the desired land area, and the opening size is defined by the copper pad width. Figure 23 shows the appropriate diameters for a MicroSiP layout.

11.2 Layout Example

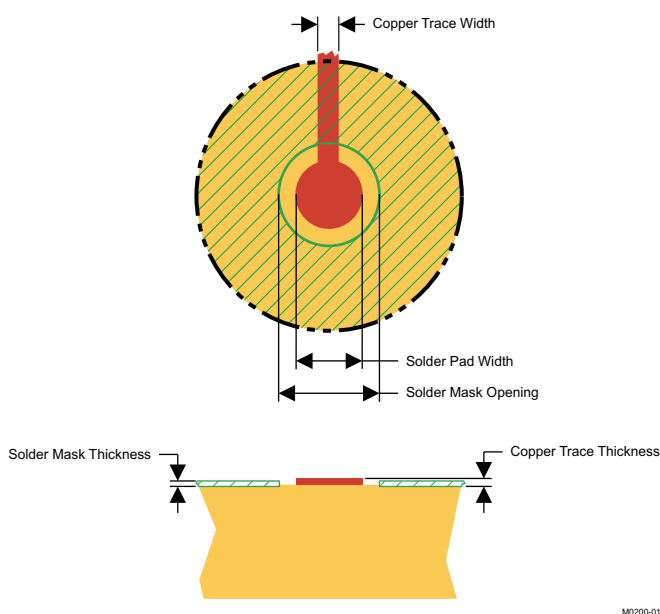

Figure 23. Recommended Land Pattern Image and Dimensions

SOLDER PAD DEFINITIONS ⁽¹⁾⁽²⁾⁽³⁾⁽⁴⁾	COPPER PAD	SOLDER MASK ⁽⁵⁾ OPENING	COPPER THICKNESS	STENCIL ⁽⁶⁾ OPENING	STENCIL THICKNESS
Non-solder-mask defined (NSMD)	0.30mm	0.360mm	1oz max (0.032mm)	0.34mm diameter	0.1mm thick

- (1) Circuit traces from non-solder-mask defined PWB lands should be 75 μ m to 100 μ m wide in the exposed area inside the solder mask opening. Wider trace widths reduce device stand off and affect reliability.
- (2) Best reliability results are achieved when the PWB laminate glass transition temperature is above the operating the range of the intended application.
- (3) Recommend solder paste is Type 3 or Type 4.
- (4) For a PWB using a Ni/Au surface finish, the gold thickness should be less than 0.5mm to avoid a reduction in thermal fatigue performance.
- (5) Solder mask thickness should be less than 20 μ m on top of the copper circuit pattern.
- (6) For best solder stencil performance use laser cut stencils with electro polishing. Chemically etched stencils give inferior solder paste volume control.

11.3 Surface Mount Information

The TPS81256 MicroSiP DC/DC converter uses an open frame construction that is designed for a fully automated assembly process and that features a large surface area for pick and place operations. See the "Pick Area" in the package drawings.

Package height and weight have been kept to a minimum thereby to allow the MicroSiP device to be handled similarly to a 0805 component.

See JEDEC/IPC standard J-STD-20b for reflow recommendations.

11.4 Thermal and Reliability Information

The TPS81256 output current may need to be de-rated if it is required to operate in a high ambient temperature or deliver a large amount of continuous power. The amount of current de-rating is dependent upon the input voltage, output power and environmental thermal conditions. Care should especially be taken in applications where the localized PWB temperature exceeds 65°C.

The TPS81256 die and inductor temperature should be kept lower than the maximum rating of 125°C, so care should be taken in the circuit layout to ensure good heat sinking. Sufficient cooling should be provided to ensure reliable operation.

To estimate the junction temperature, approximate the power dissipation within the TPS81256 by applying the typical efficiency stated in this datasheet to the desired output power; or, by taking a power measurement if you have an actual TPS81256 device or a TPS81256EVM evaluation module. Then calculate the internal temperature rise of the TPS81256 above the surface of the printed circuit board by multiplying the TPS81256 power dissipation by the thermal resistance.

The thermal resistance numbers listed in the Thermal Information table are based on modeling the MicroSiP package mounted on a high-K test board specified per JEDEC standard. For increased accuracy and fidelity to the actual application, it is recommended to run a thermal image analysis of the actual system. [Figure 24](#) and [Figure 25](#) are thermal images of TI's evaluation board with readings of the temperatures at specific locations on the device.

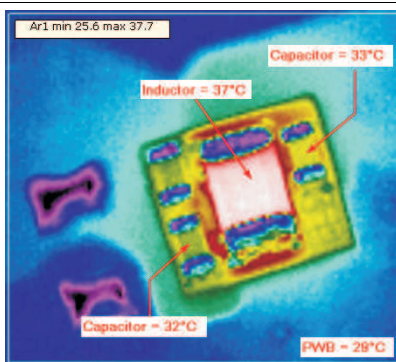

Figure 24. $V_{IN}=3.6v$, $V_{OUT}=5v$, $I_{OUT}=300ma$
150mw Power Dissipation At Room Temperature

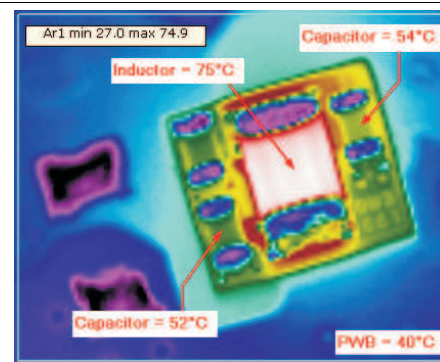

Figure 25. $V_{IN}=3.6v$, $V_{OUT}=5v$, $I_{OUT}=600ma$
600mw Power Dissipation At Room Temperature

The TPS81256 is equipped with a thermal shutdown that will inhibit power switching at high junction temperatures. The activation threshold of this function, however, is above 125°C to avoid interfering with normal operation. Thus, it follows that prolonged or repetitive operation under a condition in which the thermal shutdown activates necessarily means that the components internal to the MicroSiP™ package are subjected to high temperatures for prolonged or repetitive intervals, which may damage or impair the reliability of the device.

MLCC capacitor reliability/lifetime is dependant on temperature and applied voltage conditions. At higher temperatures, MLCC capacitors are subject to stronger stress. On the basis of frequently evaluated failure rates determined at standardized test conditions, the reliability of all MLCC capacitors can be calculated for their actual operating temperature and voltage.

Thermal and Reliability Information (continued)

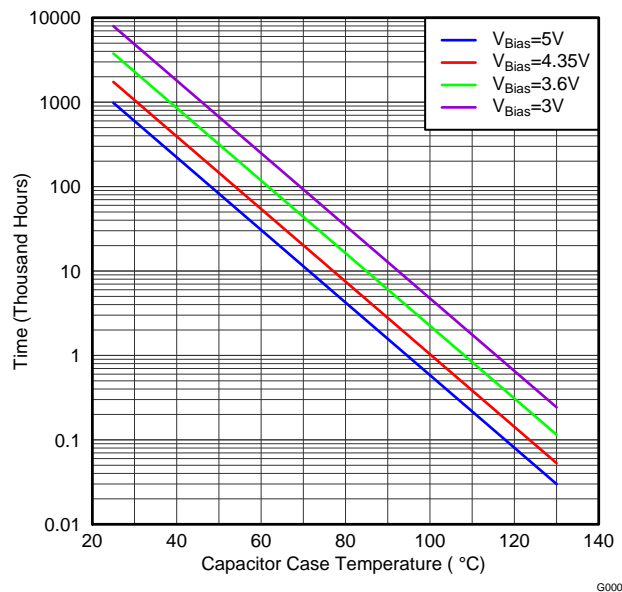

Figure 26. Capacitor Lifetime vs Capacitor Case Temperature

Failures caused by systematic degradation can be described by the Arrhenius model. The most critical parameter (IR) is the Insulation Resistance (i.e. leakage current). The drop of IR below a lower limit (e.g. 1 MΩ) is used as the failure criterion, see Figure 26. It should be noted that the wear-out mechanisms occurring in the MLCC capacitors are not reversible but cumulative over time.

12 器件和文档支持

12.1 器件支持

12.1.1 第三方产品免责声明

TI 发布的与第三方产品或服务有关的信息，不能构成与此类产品或服务或保修的适用性有关的认可，不能构成此类产品或服务单独或与任何 TI 产品或服务一起的表示或认可。

12.2 社区资源

下列链接提供到 TI 社区资源的连接。链接的内容由各个分销商“按照原样”提供。这些内容并不构成 TI 技术规范，并且不一定反映 TI 的观点；请参阅 TI 的《使用条款》。

TI E2E™ 在线社区 *TI 的工程师对工程师 (E2E) 社区*。此社区的创建目的在于促进工程师之间的协作。在 e2e.ti.com 中，您可以咨询问题、分享知识、拓展思路并与同行工程师一道帮助解决问题。

设计支持 *TI 参考设计支持* 可帮助您快速查找有帮助的 E2E 论坛、设计支持工具以及技术支持的联系信息。

12.3 商标

MicroSiP, E2E are trademarks of Texas Instruments.
All other trademarks are the property of their respective owners.

12.4 静电放电警告



这些装置包含有限的内置 ESD 保护。存储或装卸时，应将导线一起截短或将装置放置于导电泡棉中，以防止 MOS 门极遭受静电损伤。

12.5 Glossary

SLYZ022 — *TI Glossary*.

This glossary lists and explains terms, acronyms, and definitions.

13 机械、封装和可订购信息

以下页面包含机械、封装和可订购信息。这些信息是指定器件的最新可用数据。数据如有变更，恕不另行通知和修订此文档。如欲获取此数据表的浏览器版本，请参阅左侧的导航。

MicroSiP 直流/直流模块封装尺寸

TPS81256 器件采用 9 凸点球栅阵列 (BGA) 封装。封装尺寸为:

- $D = 2.925 \pm 0.05\text{mm}$
- $E = 2.575 \pm 0.05\text{mm}$

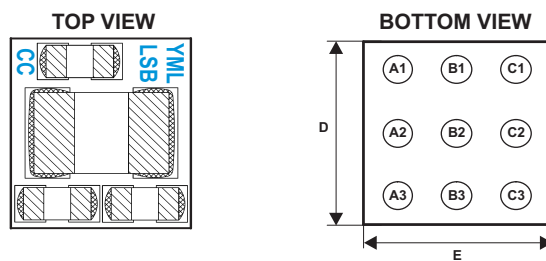

代码:

- CC - 封装标记芯片代码 (参阅“封装选项附录”获取更多详细信息)
- YML—Y: 年, M: 月, L: 批次跟踪码
- LSB—L: 批次跟踪码, S: 地点代码, B: 主板定位器

图 27. μ SIP 9 引脚尺寸和标记



PACKAGE OUTLINE

SIP0009A

MicroSiP™ - 1 mm max height

MICRO SYSTEM IN PACKAGE

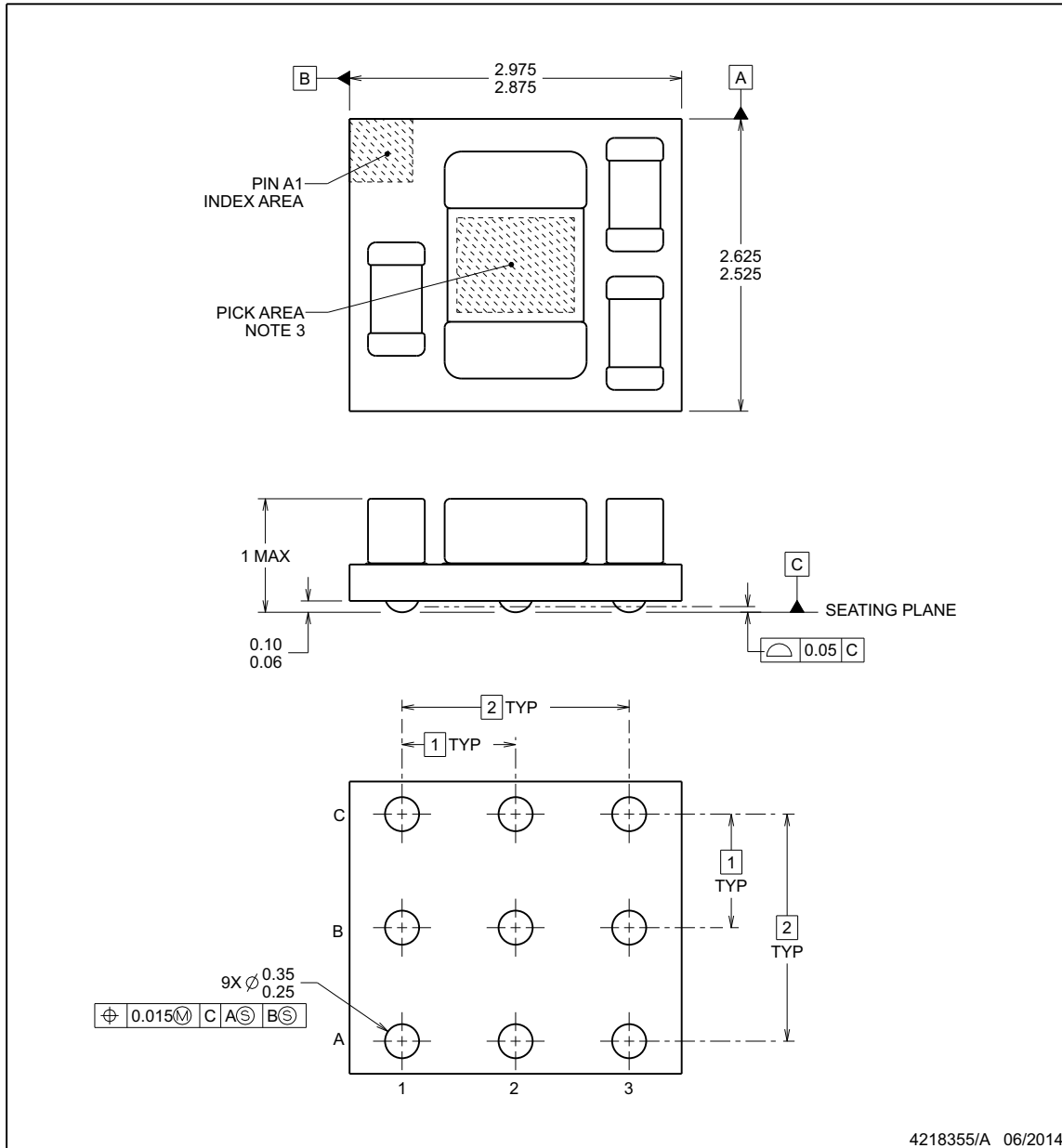

MicroSiP is a trademark of Texas Instruments.

NOTES:

1. All linear dimensions are in millimeters. Any dimensions in parenthesis are for reference only. Dimensioning and tolerancing per ASME Y14.5M.
2. This drawing is subject to change without notice.
3. For pick and place nozzle recommendation, see product datasheet.
4. Location, size and quantity of each component are for reference only and may vary.

EXAMPLE BOARD LAYOUT

SIP0009A

MicroSiP™ - 1 mm max height

MICRO SYSTEM IN PACKAGE

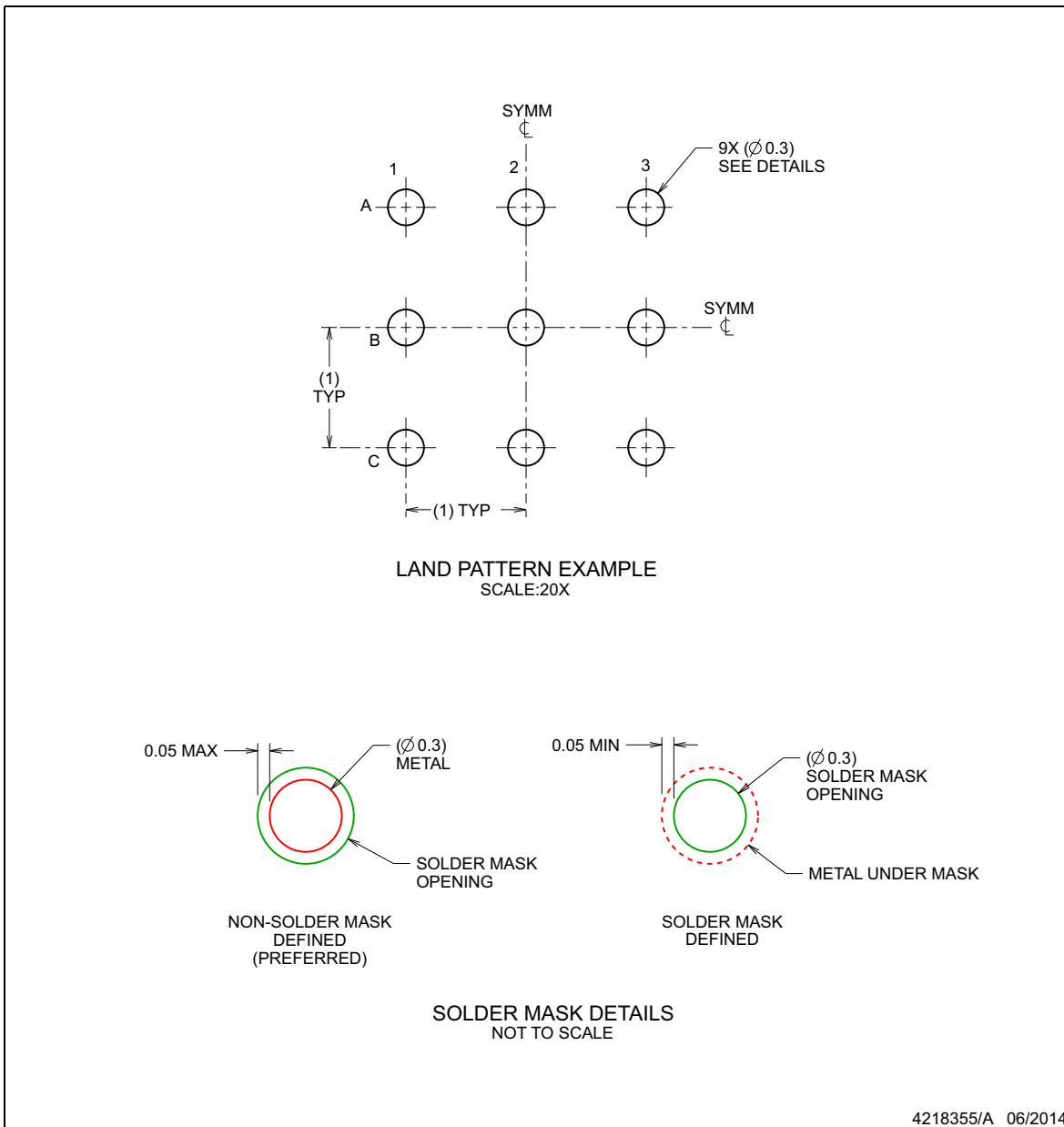

NOTES: (continued)

5. For more information, see Texas Instruments literature number SBVA017 (www.ti.com/lit/sbva017).

EXAMPLE STENCIL DESIGN

SIP0009A

MicroSiP™ - 1 mm max height

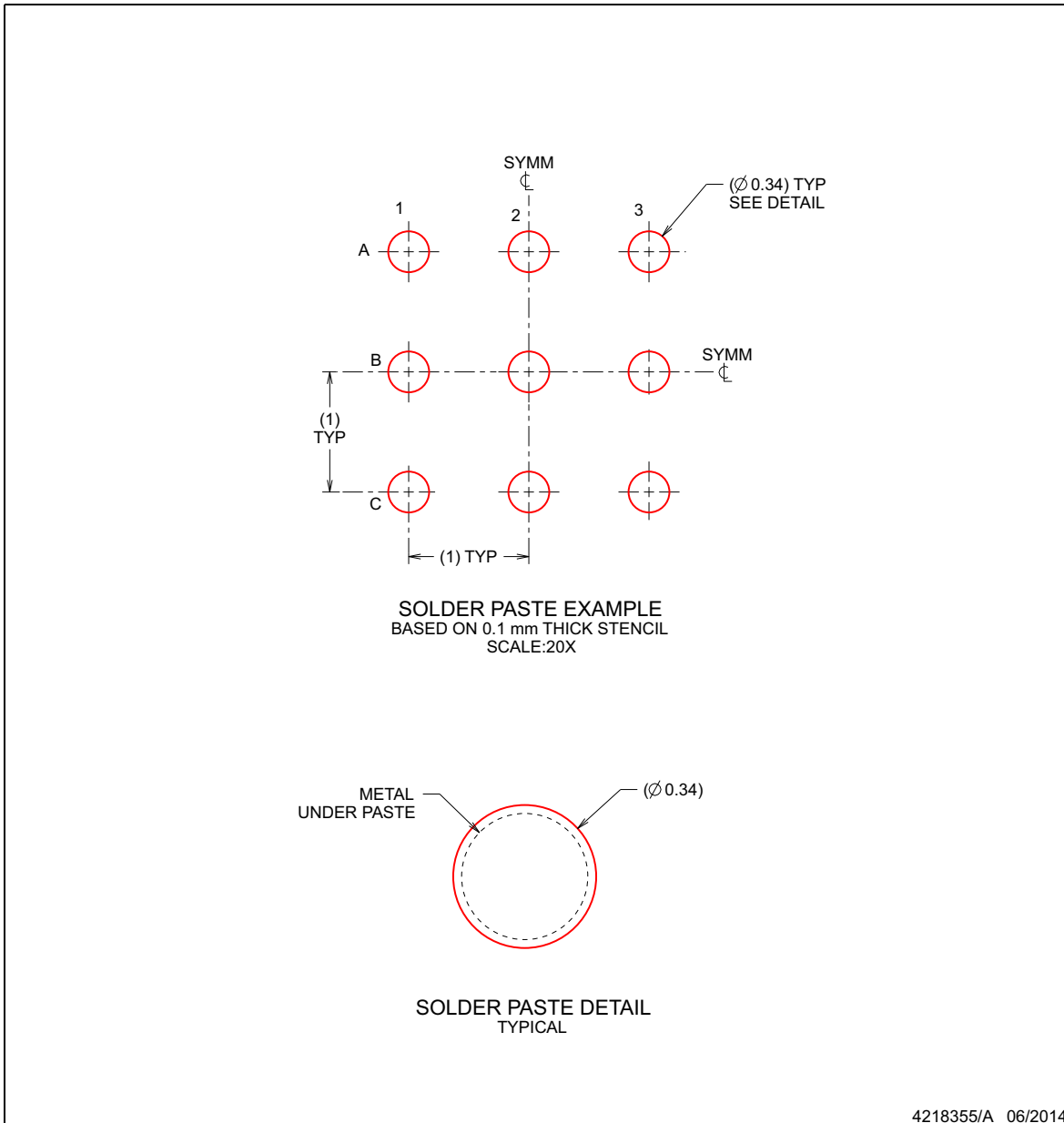

MICRO SYSTEM IN PACKAGE



NOTES: (continued)

6. Laser cutting apertures with trapezoidal walls and rounded corners may offer better paste release. IPC-7525 may have alternate design recommendations.

PACKAGING INFORMATION

Orderable Device	Status (1)	Package Type	Package Drawing	Pins	Package Qty	Eco Plan (2)	Lead finish/ Ball material (6)	MSL Peak Temp (3)	Op Temp (°C)	Device Marking (4/5)	Samples
TPS81256SIPR	ACTIVE	uSiP	SIP	9	3000	RoHS (In Work) & Green (In Work)	OSP	Level-2-260C-1 YEAR	-40 to 85	TT	
TPS81256SIPT	ACTIVE	uSiP	SIP	9	250	RoHS (In Work) & Green (In Work)	OSP	Level-2-260C-1 YEAR	-40 to 85	TT	

(1) The marketing status values are defined as follows:

ACTIVE: Product device recommended for new designs.

LIFEBUY: TI has announced that the device will be discontinued, and a lifetime-buy period is in effect.

NRND: Not recommended for new designs. Device is in production to support existing customers, but TI does not recommend using this part in a new design.

PREVIEW: Device has been announced but is not in production. Samples may or may not be available.

OBSELETE: TI has discontinued the production of the device.

(2) **RoHS:** TI defines "RoHS" to mean semiconductor products that are compliant with the current EU RoHS requirements for all 10 RoHS substances, including the requirement that RoHS substance do not exceed 0.1% by weight in homogeneous materials. Where designed to be soldered at high temperatures, "RoHS" products are suitable for use in specified lead-free processes. TI may reference these types of products as "Pb-Free".

RoHS Exempt: TI defines "RoHS Exempt" to mean products that contain lead but are compliant with EU RoHS pursuant to a specific EU RoHS exemption.

Green: TI defines "Green" to mean the content of Chlorine (Cl) and Bromine (Br) based flame retardants meet JS709B low halogen requirements of <=1000ppm threshold. Antimony trioxide based flame retardants must also meet the <=1000ppm threshold requirement.

(3) MSL, Peak Temp. - The Moisture Sensitivity Level rating according to the JEDEC industry standard classifications, and peak solder temperature.

(4) There may be additional marking, which relates to the logo, the lot trace code information, or the environmental category on the device.

(5) Multiple Device Markings will be inside parentheses. Only one Device Marking contained in parentheses and separated by a "-" will appear on a device. If a line is indented then it is a continuation of the previous line and the two combined represent the entire Device Marking for that device.

(6) Lead finish/Ball material - Orderable Devices may have multiple material finish options. Finish options are separated by a vertical ruled line. Lead finish/Ball material values may wrap to two lines if the finish value exceeds the maximum column width.

Important Information and Disclaimer: The information provided on this page represents TI's knowledge and belief as of the date that it is provided. TI bases its knowledge and belief on information provided by third parties, and makes no representation or warranty as to the accuracy of such information. Efforts are underway to better integrate information from third parties. TI has taken and continues to take reasonable steps to provide representative and accurate information but may not have conducted destructive testing or chemical analysis on incoming materials and chemicals. TI and TI suppliers consider certain information to be proprietary, and thus CAS numbers and other limited information may not be available for release.

In no event shall TI's liability arising out of such information exceed the total purchase price of the TI part(s) at issue in this document sold by TI to Customer on an annual basis.

TAPE AND REEL INFORMATION

QUADRANT ASSIGNMENTS FOR PIN 1 ORIENTATION IN TAPE

*All dimensions are nominal

Device	Package Type	Package Drawing	Pins	SPQ	Reel Diameter (mm)	Reel Width W1 (mm)	A0 (mm)	B0 (mm)	K0 (mm)	P1 (mm)	W (mm)	Pin1 Quadrant
TPS81256SIPR	uSiP	SIP	9	3000	178.0	9.0	2.83	3.18	1.2	4.0	8.0	Q2
TPS81256SIPT	uSiP	SIP	9	250	178.0	9.0	2.83	3.18	1.2	4.0	8.0	Q2

TAPE AND REEL BOX DIMENSIONS

*All dimensions are nominal

Device	Package Type	Package Drawing	Pins	SPQ	Length (mm)	Width (mm)	Height (mm)
TPS81256SIPR	uSiP	SIP	9	3000	223.0	194.0	35.0
TPS81256SIPT	uSiP	SIP	9	250	223.0	194.0	35.0

重要声明和免责声明

TI 提供技术和可靠性数据（包括数据表）、设计资源（包括参考设计）、应用或其他设计建议、网络工具、安全信息和其他资源，不保证没有瑕疵且不做任何明示或暗示的担保，包括但不限于对适销性、某特定用途方面的适用性或不侵犯任何第三方知识产权的暗示担保。

这些资源可供使用 TI 产品进行设计的熟练开发人员使用。您将自行承担以下全部责任：(1) 针对您的应用选择合适的 TI 产品，(2) 设计、验证并测试您的应用，(3) 确保您的应用满足相应标准以及任何其他安全、安保或其他要求。这些资源如有变更，恕不另行通知。TI 授权您仅可将这些资源用于研发本资源所述的 TI 产品的应用。严禁对这些资源进行其他复制或展示。您无权使用任何其他 TI 知识产权或任何第三方知识产权。您应全额赔偿因在这些资源的使用中对 TI 及其代表造成的任何索赔、损害、成本、损失和债务，TI 对此概不负责。

TI 提供的产品受 TI 的销售条款 (<https://www.ti.com.cn/zh-cn/legal/termsofsale.html>) 或 [ti.com.cn](https://www.ti.com.cn) 上其他适用条款/TI 产品随附的其他适用条款的约束。TI 提供这些资源并不会扩展或以其他方式更改 TI 针对 TI 产品发布的适用的担保或担保免责声明。

邮寄地址：上海市浦东新区世纪大道 1568 号中建大厦 32 楼，邮政编码：200122

Copyright © 2021 德州仪器半导体技术（上海）有限公司