

## TS5A9411 10-Ω 1:2 SPDT Analog Switch Single-Channel 2:1 Multiplexer and Demultiplexer

### 1 Features

- Specified Break-Before-Make Switching
- Low ON-State Resistance (10-Ω Maximum at  $V_{CC} = 5\text{ V}$ )
- Low Power Consumption
- TTL- and CMOS-Compatible Control Input
- Low Input and Output Capacitance
- Excellent ON-State Resistance Matching
- Low Total Harmonic Distortion
- 2.25-V to 5.5-V Single-Supply Operation
- Latch-Up Performance Exceeds 100 mA Per JESD 78, Class II
- ESD Performance Tested Per JESD 22
  - 2000-V Human-Body Model (A114-B, Class II)
  - 1000-V Charged-Device Model (C101)
- Control Inputs Are 5.5-V Tolerant

### 2 Applications

- Cell Phones
- Communication Systems
- Portable Test Equipment
- Battery Operated Systems
- Sample-and-Hold Circuits

### 3 Description

The TS5A9411 device is a bidirectional, single-pole double-throw (SPDT) analog switch that is designed to operate from 2.25 V to 5.5 V. The device offers low ON-state resistance, low leakage, and low power with a break-before-make feature. These features make this device suitable for portable and battery-powered applications.

#### Device Information<sup>(1)</sup>

PART NUMBER	PACKAGE	BODY SIZE (NOM)
TS5A9411	SOT (6)	2.00 mm × 1.25 mm

(1) For all available packages, see the orderable addendum at the end of the data sheet.

#### Simplified Schematic

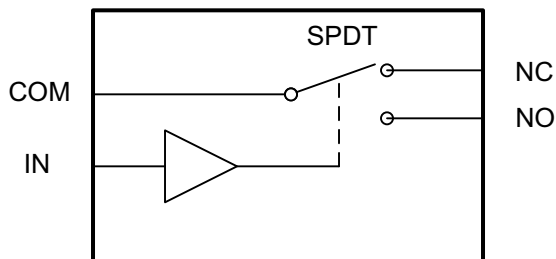

## Table of Contents

<b>1 Features</b> .....	<b>1</b>	8.3 Feature Description .....	<b>12</b>
<b>2 Applications</b> .....	<b>1</b>	8.4 Device Functional Modes .....	<b>12</b>
<b>3 Description</b> .....	<b>1</b>	<b>9 Application and Implementation</b> .....	<b>13</b>
<b>4 Revision History</b> .....	<b>2</b>	9.1 Application Information .....	<b>13</b>
<b>5 Pin Configuration and Functions</b> .....	<b>3</b>	9.2 Typical Application .....	<b>13</b>
<b>6 Specifications</b> .....	<b>3</b>	<b>10 Power Supply Recommendations</b> .....	<b>14</b>
6.1 Absolute Maximum Ratings .....	<b>3</b>	<b>11 Layout</b> .....	<b>14</b>
6.2 ESD Ratings .....	<b>3</b>	11.1 Layout Guidelines .....	<b>14</b>
6.3 Recommended Operating Conditions .....	<b>4</b>	11.2 Layout Example .....	<b>14</b>
6.4 Thermal Information .....	<b>4</b>	<b>12 Device and Documentation Support</b> .....	<b>15</b>
6.5 Electrical Characteristics: 5-V Supply .....	<b>4</b>	12.1 Device Support .....	<b>15</b>
6.6 Electrical Characteristics: 3-V Supply .....	<b>5</b>	12.2 Documentation Support .....	<b>16</b>
6.7 Electrical Characteristics: 2.5-V Supply .....	<b>6</b>	12.3 Receiving Notification of Documentation Updates .....	<b>16</b>
6.8 Typical Characteristics .....	<b>7</b>	12.4 Community Resources .....	<b>16</b>
<b>7 Parameter Measurement Information</b> .....	<b>8</b>	12.5 Trademarks .....	<b>16</b>
<b>8 Detailed Description</b> .....	<b>12</b>	12.6 Electrostatic Discharge Caution .....	<b>16</b>
8.1 Overview .....	<b>12</b>	12.7 Glossary .....	<b>16</b>
8.2 Functional Block Diagram .....	<b>12</b>	<b>13 Mechanical, Packaging, and Orderable Information</b> .....	<b>17</b>

## 4 Revision History

NOTE: Page numbers for previous revisions may differ from page numbers in the current version.

<b>Changes from Revision A (July 2008) to Revision B</b>	<b>Page</b>
• Added <i>Device Information</i> table, <i>Pin Configuration and Functions</i> section, <i>Specifications</i> section, <i>ESD Ratings</i> table, <i>Recommended Operating Conditions</i> table, <i>Detailed Description</i> section, <i>Application and Implementation</i> section, <i>Power Supply Recommendations</i> section, <i>Layout</i> section, <i>Device and Documentation Support</i> section, and <i>Mechanical, Packaging, and Orderable Information</i> section .....	<b>1</b>
• Deleted <i>Ordering Information</i> table; see <i>Package Option Addendum</i> at the end of the data sheet .....	<b>1</b>
• Deleted <i>Summary of Characteristics</i> table .....	<b>1</b>
• Moved ON-state switch current and ON-state peak switch current From: <i>Absolute Maximum Ratings</i> table To: <i>Recommended Operating Conditions</i> table .....	<b>4</b>
• Added <i>Thermal Information</i> table .....	<b>4</b>
• Changed Package thermal impedance, $R_{\theta JA}$ , value in <i>Thermal Information</i> table From: 259°C/W To: 346.7°C/W .....	<b>4</b>
• Deleted <i>Charge Injection vs <math>V_{COM}</math></i> graph from <i>Typical Characteristics</i> .....	<b>7</b>
• Changed graph title From: OFF Isolation vs Crosstalk ( $V_{CC} = 3\text{ V}$ ) To: Crosstalk and Insertion Loss vs Frequency ( $V_{CC} = 3\text{ V}$ ) in <i>Typical Characteristics</i> .....	<b>7</b>
• Changed $V+$ to $V_{CC}$ and IN to $V_{IN}$ on all images in <i>Parameter Measurement Information</i> .....	<b>8</b>

## 5 Pin Configuration and Functions

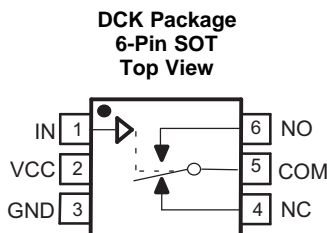

### Pin Functions

PIN		I/O	DESCRIPTION
NAME	NO.		
COM	5	I/O	Common signal path
GND	3	—	Digital ground
IN	1	I	Digital control input. High = COM connected to NO; Low = COM connected to NC.
NC	4	I/O	Normally closed signal path
NO	6	I/O	Normally open signal path
VCC	2	—	Power supply

## 6 Specifications

### 6.1 Absolute Maximum Ratings

over operating free-air temperature range (unless otherwise noted)<sup>(1)(2)</sup>

	MIN	MAX	UNIT
Supply voltage	−0.3	6	V
Analog voltage <sup>(3)</sup>	−0.3	$V_{CC} + 0.3$	V
Digital input voltage	−0.5	$V_{CC} + 0.3$	V
Analog port diode current ( $V_{NC}, V_{NO}, V_{COM} < 0$ )	−50		mA
Digital input clamp current ( $V_I < 0$ )	−50		mA
Continuous current through VCC		100	mA
Continuous current through GND	−100		mA
Storage temperature, $T_{stg}$	−65	150	°C

(1) Stresses beyond those listed under *Absolute Maximum Ratings* may cause permanent damage to the device. These are stress ratings only, which do not imply functional operation of the device at these or any other conditions beyond those indicated under *Recommended Operating Conditions*. Exposure to absolute-maximum-rated conditions for extended periods may affect device reliability.

(2) All voltages are with respect to ground, unless otherwise specified.

(3) This value is limited to 5.5 V (maximum).

### 6.2 ESD Ratings

		VALUE	UNIT
$V_{(ESD)}$	Electrostatic discharge	Human-body model (HBM), per ANSI/ESDA/JEDEC JS-001 <sup>(1)</sup>	±2000
		Charged-device model (CDM), per JEDEC specification JESD22-C101 <sup>(2)</sup>	±1000

(1) JEDEC document JEP155 states that 500-V HBM allows safe manufacturing with a standard ESD control process.

(2) JEDEC document JEP157 states that 250-V CDM allows safe manufacturing with a standard ESD control process.

### 6.3 Recommended Operating Conditions

over operating free-air temperature range (unless otherwise noted)

			MIN	MAX	UNIT
V <sub>CC</sub>	Supply voltage		2.25	5.5	V
V <sub>NO</sub>	Analog voltage	NC	0	V <sub>CC</sub>	V
V <sub>NC</sub>		NO	0	V <sub>CC</sub>	
V <sub>COM</sub>		COM	0	V <sub>CC</sub>	
V <sub>I</sub>	Digital input voltage		0	5.5	V
ON-state switch current (V <sub>NO</sub> , V <sub>NC</sub> , V <sub>COM</sub> = 0 to V <sub>CC</sub> )			-50	50	mA
ON-state peak switch current (V <sub>NO</sub> , V <sub>NC</sub> , V <sub>COM</sub> = 0 to V <sub>CC</sub> ) <sup>(1)</sup>			-200	200	mA

(1) Pulse at 1-ms duration &lt; 10% duty cycle

### 6.4 Thermal Information

THERMAL METRIC <sup>(1)</sup>		TS5A9411	UNIT
		DCK (SOT)	
		12 PINS	
R <sub>θJA</sub>	Junction-to-ambient thermal resistance	346.7	°C/W
R <sub>θJC(top)</sub>	Junction-to-case (top) thermal resistance	163.7	°C/W
R <sub>θJB</sub>	Junction-to-board thermal resistance	154.5	°C/W
ψ <sub>JT</sub>	Junction-to-top characterization parameter	17.4	°C/W
ψ <sub>JB</sub>	Junction-to-board characterization parameter	153.8	°C/W

 (1) For more information about traditional and new thermal metrics, see the [Semiconductor and IC Package Thermal Metrics](#) application report.

### 6.5 Electrical Characteristics: 5-V Supply

 V<sub>CC</sub> = 5 V, T<sub>A</sub> = 25°C (unless otherwise noted)

PARAMETER		TEST CONDITIONS	MIN	TYP	MAX	UNIT
<b>ANALOG SWITCH</b>						
r <sub>ON</sub>	ON-state resistance	V <sub>NO</sub> or V <sub>NC</sub> = 3 V, V <sub>CC</sub> = 4.5 V, I <sub>COM</sub> = -10 mA, Switch ON, see <a href="#">Figure 5</a>	T <sub>A</sub> = 25°C -40°C ≤ T <sub>A</sub> ≤ 85°C		5.3 9	Ω
Δr <sub>ON</sub>	ON-state resistance match between channels	V <sub>NO</sub> or V <sub>NC</sub> = 3 V, V <sub>CC</sub> = 4.5 V, I <sub>COM</sub> = -10 mA, Switch ON, see <a href="#">Figure 5</a>	T <sub>A</sub> = 25°C -40°C ≤ T <sub>A</sub> ≤ 85°C		0.03 0.3	Ω
r <sub>ON(FLAT)</sub>	ON-state resistance flatness	0 ≤ (V <sub>NO</sub> or V <sub>NC</sub> ) ≤ V <sub>CC</sub> , V <sub>CC</sub> = 4.5 V, I <sub>COM</sub> = -10 mA, Switch ON, see <a href="#">Figure 5</a>			2	Ω
I <sub>NC(OFF)</sub> , I <sub>NO(OFF)</sub>	NC, NO OFF leakage current	V <sub>NC</sub> or V <sub>NO</sub> = 1 V and V <sub>COM</sub> = 1 V to 4.5 V, or V <sub>NC</sub> or V <sub>NO</sub> = 4.5 V and V <sub>COM</sub> = 1 V; V <sub>CC</sub> = 5.5 V, Switch OFF, see <a href="#">Figure 6</a>	T <sub>A</sub> = 25°C -40°C ≤ T <sub>A</sub> ≤ 85°C		-500 -3	500 3 pA nA
I <sub>NC(ON)</sub> , I <sub>NO(ON)</sub>	NC, NO ON leakage current	V <sub>NC</sub> or V <sub>NO</sub> = 1 V and V <sub>COM</sub> = 1 V, or V <sub>NC</sub> or V <sub>NO</sub> = 4.5 V and V <sub>COM</sub> = 4.5 V; V <sub>CC</sub> = 5.5 V, Switch ON, see <a href="#">Figure 7</a>	T <sub>A</sub> = 25°C -40°C ≤ T <sub>A</sub> ≤ 85°C		-500 -3	500 3 pA nA
I <sub>COM(ON)</sub>	COM ON leakage current	V <sub>NC</sub> or V <sub>NO</sub> = Open, V <sub>COM</sub> = 1 V or 4.5 V, V <sub>CC</sub> = 5.5 V, Switch ON, see <a href="#">Figure 7</a>	T <sub>A</sub> = 25°C -40°C ≤ T <sub>A</sub> ≤ 85°C		-500 -3	500 3 pA nA
<b>DIGITAL INPUT (IN)<sup>(1)</sup></b>						
V <sub>IH</sub>	Input logic high	-40°C ≤ T <sub>A</sub> ≤ 85°C	4.5 V ≤ V <sub>CC</sub> ≤ 5.5 V V <sub>CC</sub> = 4.5 V		2.4 2	5.5 5.5 V
V <sub>IL</sub>	Input logic low	4.5 V ≤ V <sub>CC</sub> ≤ 5.5 V, -40°C ≤ T <sub>A</sub> ≤ 85°C		0	0.8	V
I <sub>IH</sub> , I <sub>IL</sub>	Input leakage current	V <sub>I</sub> = 5.5 V or 0, V <sub>CC</sub> = 5.5 V	T <sub>A</sub> = 25°C -40°C ≤ T <sub>A</sub> ≤ 85°C		-0.05 -0.05	0.05 0.05 μA
<b>DYNAMIC</b>						
t <sub>ON</sub>	Turnon time	V <sub>COM</sub> = 3 V, R <sub>L</sub> = 300 Ω, C <sub>L</sub> = 35 pF, see <a href="#">Figure 9</a>	V <sub>CC</sub> = 5 V, T <sub>A</sub> = 25°C 4.5 V ≤ V <sub>CC</sub> ≤ 5.5 V, -40°C ≤ T <sub>A</sub> ≤ 85°C		9 10	ns

 (1) All unused digital inputs of the device must be held at V<sub>CC</sub> or GND to ensure proper device operation. See [Implications of Slow or Floating CMOS Inputs](#) (SCBA004).

## Electrical Characteristics: 5-V Supply (continued)

 $V_{CC} = 5\text{ V}$ ,  $T_A = 25^\circ\text{C}$  (unless otherwise noted)

PARAMETER		TEST CONDITIONS		MIN	TYP	MAX	UNIT
$t_{OFF}$	Turnoff time	$V_{COM} = 3\text{ V}$ , $R_L = 300\ \Omega$ , $C_L = 35\text{ pF}$ , see <a href="#">Figure 9</a>	$V_{CC} = 5\text{ V}$ , $T_A = 25^\circ\text{C}$			7	ns
			$4.5\text{ V} \leq V_{CC} \leq 5.5\text{ V}$ , $-40^\circ\text{C} \leq T_A \leq 85^\circ\text{C}$			7.5	
$t_{BBM}$	Break-before-make time	$V_{NC} = V_{NO} = 3\text{ V}$ , $R_L = 300\ \Omega$ , $C_L = 35\text{ pF}$ , see <a href="#">Figure 10</a>	$T_A = 25^\circ\text{C}$			1	ns
			$-40^\circ\text{C} \leq T_A \leq 85^\circ\text{C}$			0.9	
$Q_C$	Charge injection	$V_{GEN} = 0$ , $R_{GEN} = 0$ , $C_L = 1\text{ nF}$ , see <a href="#">Figure 14</a>				12.5	pC
$C_{NC(OFF)}$ , $C_{NO(OFF)}$	NC, NO OFF capacitance	$V_{NC}$ or $V_{NO} = V_{CC}$ or GND, $f = 1\text{ MHz}$ , Switch OFF, see <a href="#">Figure 8</a>				3.5	pF
$C_{NC(ON)}$ , $C_{NO(ON)}$	NC, NO ON capacitance	$V_{NC}$ or $V_{NO} = V_{CC}$ or GND, $f = 1\text{ MHz}$ , see <a href="#">Figure 8</a>				8.5	pF
$C_{COM(ON)}$	COM ON capacitance	$V_{COM} = V_{CC}$ or GND, $f = 1\text{ MHz}$ , Switch ON, see <a href="#">Figure 8</a>				8.5	pF
$C_I$	Digital input capacitance	$V_I = V_{CC}$ or GND, $f = 1\text{ MHz}$ , see <a href="#">Figure 8</a>				25	pF
BW	Bandwidth	$R_L = 50\ \Omega$ , Switch ON, see <a href="#">Figure 11</a>				100	MHz
$O_{ISO}$	OFF isolation	$R_L = 50\ \Omega$ , $C_L = 5\text{ pF}$ , $f = 1\text{ MHz}$ , Switch OFF, see <a href="#">Figure 12</a>				-84	dB
$X_{TALK}$	Crosstalk	$R_L = 50\ \Omega$ , $C_L = 5\text{ pF}$ , $f = 1\text{ MHz}$ , Switch ON, see <a href="#">Figure 13</a>				-85	dB
THD	Total harmonic distortion	$R_L = 600\ \Omega$ , $C_L = 50\text{ pF}$ , $f = 20\text{ Hz}$ to $20\text{ kHz}$ , see <a href="#">Figure 15</a>				0.03%	
<b>SUPPLY</b>							
$I_{CC}$	Positive supply current	$V_I = V_{CC}$ or GND, $V_{CC} = 5.5\text{ V}$ , Switch ON or OFF	$T_A = 25^\circ\text{C}$			0.01	$\mu\text{A}$
			$-40^\circ\text{C} \leq T_A \leq 85^\circ\text{C}$			0.5	

## 6.6 Electrical Characteristics: 3-V Supply

 $V_{CC} = 3\text{ V}$ ,  $T_A = 25^\circ\text{C}$  (unless otherwise noted)

PARAMETER		TEST CONDITIONS		MIN	TYP	MAX	UNIT	
<b>ANALOG SWITCH</b>								
$r_{ON}$	ON-state resistance	$V_{NO}$ or $V_{NC} = 1.5\text{ V}$ , $V_{CC} = 2.7\text{ V}$ , $I_{COM} = -10\text{ mA}$ , Switch ON, see <a href="#">Figure 5</a>	$T_A = 25^\circ\text{C}$			11.5	$\Omega$	
			$-40^\circ\text{C} \leq T_A \leq 85^\circ\text{C}$			20		
$\Delta r_{ON}$	ON-state resistance match between channels	$V_{NO}$ or $V_{NC} = 1.5\text{ V}$ , $V_{CC} = 2.7\text{ V}$ , $I_{COM} = -10\text{ mA}$ , Switch ON, see <a href="#">Figure 5</a>	$T_A = 25^\circ\text{C}$			0.05	$\Omega$	
			$-40^\circ\text{C} \leq T_A \leq 85^\circ\text{C}$			0.3		
$r_{ON(FLAT)}$	ON-state resistance flatness	$0 \leq (V_{NO} \text{ or } V_{NC}) \leq V_{CC}$ , $I_{COM} = -10\text{ mA}$ , Switch ON, see <a href="#">Figure 5</a>				2	$\Omega$	
$I_{NC(OFF)}$ , $I_{NO(OFF)}$	NC, NO OFF leakage current	$V_{NC}$ or $V_{NO} = 1\text{ V}$ and $V_{COM} = 1\text{ V}$ to $3\text{ V}$ , or $V_{NC}$ or $V_{NO} = 3\text{ V}$ and $V_{COM} = 1\text{ V}$ ; $V_{CC} = 3.3\text{ V}$ , Switch OFF, see <a href="#">Figure 6</a>	$T_A = 25^\circ\text{C}$			-400	400	pA
			$-40^\circ\text{C} \leq T_A \leq 85^\circ\text{C}$			-2	2	nA
$I_{NC(ON)}$ , $I_{NO(ON)}$	NC, NO ON leakage current	$V_{NC}$ or $V_{NO} = 1\text{ V}$ and $V_{COM} = 1\text{ V}$ , or $V_{NC}$ or $V_{NO} = 3\text{ V}$ and $V_{COM} = 3\text{ V}$ ; $V_{CC} = 3.3\text{ V}$ , Switch ON, see <a href="#">Figure 7</a>	$T_A = 25^\circ\text{C}$			-400	400	pA
			$-40^\circ\text{C} \leq T_A \leq 85^\circ\text{C}$			-2	2	nA
$I_{COM(ON)}$	COM ON leakage current	$V_{NC}$ or $V_{NO} = \text{Open}$ , $V_{COM} = 1\text{ V}$ or $3\text{ V}$ , $V_{CC} = 3.3\text{ V}$ , Switch ON, see <a href="#">Figure 7</a>	$T_A = 25^\circ\text{C}$			-400	400	pA
			$-40^\circ\text{C} \leq T_A \leq 85^\circ\text{C}$			-2	2	nA
<b>DIGITAL INPUT (IN)<sup>(1)</sup></b>								
$V_{IH}$	Input logic high	$-40^\circ\text{C} \leq T_A \leq 85^\circ\text{C}$				2	5.5	V
$V_{IL}$	Input logic low	$-40^\circ\text{C} \leq T_A \leq 85^\circ\text{C}$				0	0.8	V
$I_{IH}$ , $I_{IL}$	Input leakage current	$V_I = 5.5\text{ V}$ or $0$ , $V_{CC} = 3.6\text{ V}$	$T_A = 25^\circ\text{C}$			-0.05	0.05	$\mu\text{A}$
			$-40^\circ\text{C} \leq T_A \leq 85^\circ\text{C}$			-0.05	0.05	
<b>DYNAMIC</b>								
$t_{ON}$	Turnon time	$V_{COM} = 3\text{ V}$ , $R_L = 300\ \Omega$ , $C_L = 35\text{ pF}$ , see <a href="#">Figure 9</a>	$V_{CC} = 3.3\text{ V}$ , $T_A = 25^\circ\text{C}$			13	ns	
			$2.7\text{ V} \leq V_{CC} \leq 3.3\text{ V}$ , $-40^\circ\text{C} \leq T_A \leq 85^\circ\text{C}$			15		
$t_{OFF}$	Turnoff time	$V_{COM} = 3\text{ V}$ , $R_L = 300\ \Omega$ , $C_L = 35\text{ pF}$ , see <a href="#">Figure 9</a>	$V_{CC} = 3.3\text{ V}$ , $T_A = 25^\circ\text{C}$			7.5	ns	
			$2.7\text{ V} \leq V_{CC} \leq 3.3\text{ V}$ , $-40^\circ\text{C} \leq T_A \leq 85^\circ\text{C}$			8.5		
$t_{BBM}$	Break-before-make time	$V_{NC} = V_{NO} = 3\text{ V}$ , $R_L = 300\ \Omega$ , $V_{CC} = 3.3\text{ V}$ , $C_L = 35\text{ pF}$ , see <a href="#">Figure 10</a>	$T_A = 25^\circ\text{C}$			1	ns	
			$-40^\circ\text{C} \leq T_A \leq 85^\circ\text{C}$			0.9		
$Q_C$	Charge injection	$V_{GEN} = 0$ , $R_{GEN} = 0$ , $C_L = 1\text{ nF}$ , see <a href="#">Figure 14</a>				6	pC	

(1) All unused digital inputs of the device must be held at  $V_{CC}$  or GND to ensure proper device operation. See [Implications of Slow or Floating CMOS Inputs](#) (SCBA004).

## Electrical Characteristics: 3-V Supply (continued)

 $V_{CC} = 3\text{ V}$ ,  $T_A = 25^\circ\text{C}$  (unless otherwise noted)

PARAMETER		TEST CONDITIONS	MIN	TYP	MAX	UNIT
$C_{NC(OFF)}$ , $C_{NO(OFF)}$	NC, NO OFF capacitance	$V_{NC}$ or $V_{NO} = V_{CC}$ or GND, $f = 1\text{ MHz}$ , Switch OFF, see <a href="#">Figure 8</a>		3.5		pF
$C_{NC(ON)}$ , $C_{NO(ON)}$	NC, NO ON capacitance	$V_{NC}$ or $V_{NO} = V_{CC}$ or GND, $f = 1\text{ MHz}$ , Switch OFF, see <a href="#">Figure 8</a>		8.5		pF
$C_{COM(ON)}$	COM ON capacitance	$V_{COM} = V_{CC}$ or GND, $f = 1\text{ MHz}$ , Switch OFF, see <a href="#">Figure 8</a>		8.5		pF
$C_I$	Digital input capacitance	$V_I = V_{CC}$ or GND, $f = 1\text{ MHz}$ , see <a href="#">Figure 8</a>		2.5		pF
BW	Bandwidth	$R_L = 50\ \Omega$ , Switch ON, see <a href="#">Figure 11</a>		100		MHz
$O_{ISO}$	OFF isolation	$R_L = 50\ \Omega$ , $f = 1\text{ MHz}$ , Switch OFF, see <a href="#">Figure 12</a>		-84		dB
$X_{TALK}$	Crosstalk	$R_L = 50\ \Omega$ , $f = 1\text{ MHz}$ , Switch ON, see <a href="#">Figure 13</a>		-85		dB
THD	Total harmonic distortion	$R_L = 600\ \Omega$ , $C_L = 50\text{ pF}$ , $f = 20\text{ Hz}$ to $20\text{ kHz}$ , see <a href="#">Figure 15</a>		0.09%		
<b>SUPPLY</b>						
$I_{CC}$	Positive supply current	$V_I = V_{CC}$ or GND, $V_{CC} = 3.6\text{ V}$ , Switch ON or OFF	$T_A = 25^\circ\text{C}$	0.01		$\mu\text{A}$
			$-40^\circ\text{C} \leq T_A \leq 85^\circ\text{C}$		0.5	

## 6.7 Electrical Characteristics: 2.5-V Supply

 $V_{CC} = 2.5\text{ V}$ ,  $T_A = 25^\circ\text{C}$  (unless otherwise noted)

PARAMETER		TEST CONDITIONS	MIN	TYP	MAX	UNIT
<b>ANALOG SWITCH</b>						
$r_{ON}$	ON-state resistance	$V_{NO}$ or $V_{NC} = 1\text{ V}$ , $V_{CC} = 2.25\text{ V}$ , $I_{COM} = -10\text{ mA}$ , Switch ON, see <a href="#">Figure 5</a>	$T_A = 25^\circ\text{C}$	15	25	$\Omega$
			$-40^\circ\text{C} \leq T_A \leq 85^\circ\text{C}$		28	
$\Delta r_{ON}$	ON-state resistance match between channels	$V_{NO}$ or $V_{NC} = 1\text{ V}$ , $V_{CC} = 2.25\text{ V}$ , $I_{COM} = -10\text{ mA}$ , Switch ON, see <a href="#">Figure 5</a>	$T_A = 25^\circ\text{C}$	0.06	0.3	$\Omega$
			$-40^\circ\text{C} \leq T_A \leq 85^\circ\text{C}$		0.3	
$r_{ON(FLAT)}$	ON-state resistance flatness	$0 \leq (V_{NO} \text{ or } V_{NC}) \leq V_{CC}$ , $V_{CC} = 2.25\text{ V}$ , $I_{COM} = -10\text{ mA}$ , Switch ON, see <a href="#">Figure 5</a>		4		$\Omega$
$I_{NC(OFF)}$ , $I_{NO(OFF)}$	NC, NO OFF leakage current	$V_{NC}$ or $V_{NO} = 1.5\text{ V}$ and $V_{COM} = 0.5\text{ V}$ to $1.5\text{ V}$ , or $V_{NC}$ or $V_{NO} = 1.5\text{ V}$ and $V_{COM} = 1.5\text{ V}$ ; $V_{CC} = 2.75\text{ V}$ , Switch OFF, see <a href="#">Figure 6</a>	$T_A = 25^\circ\text{C}$	-300	300	pA
			$-40^\circ\text{C} \leq T_A \leq 85^\circ\text{C}$	-1	1	nA
$I_{NC(ON)}$ , $I_{NO(ON)}$	NC, NO ON leakage current	$V_{NC}$ or $V_{NO} = 1.5\text{ V}$ and $V_{COM} = 0.5\text{ V}$ to $1.5\text{ V}$ , or $V_{NC}$ or $V_{NO} = 1.5\text{ V}$ and $V_{COM} = 1.5\text{ V}$ ; $V_{CC} = 2.75\text{ V}$ , Switch ON, see <a href="#">Figure 7</a>	$T_A = 25^\circ\text{C}$	-300	300	pA
			$-40^\circ\text{C} \leq T_A \leq 85^\circ\text{C}$	-1	1	nA
$I_{COM(ON)}$	COM ON leakage current	$V_{NC}$ or $V_{NO} = \text{Open}$ , $V_{COM} = 0.5\text{ V}$ or $1.5\text{ V}$ , $V_{CC} = 2.75\text{ V}$ , Switch ON, see <a href="#">Figure 7</a>	$T_A = 25^\circ\text{C}$	-300	300	pA
			$-40^\circ\text{C} \leq T_A \leq 85^\circ\text{C}$	-1	1	nA
<b>DIGITAL INPUT (IN)<sup>(1)</sup></b>						
$V_{IH}$	Input logic high		$-40^\circ\text{C} \leq T_A \leq 85^\circ\text{C}$	2	5.5	V
$V_{IL}$	Input logic low		$-40^\circ\text{C} \leq T_A \leq 85^\circ\text{C}$	0	0.4	V
$I_{IH}$ , $I_{IL}$	Input leakage current	$V_I = 5.5\text{ V}$ or $0\text{ V}$ , $V_{CC} = 2.75\text{ V}$	$T_A = 25^\circ\text{C}$	-0.05	0.05	$\mu\text{A}$
			$-40^\circ\text{C} \leq T_A \leq 85^\circ\text{C}$	-0.05	0.05	
<b>DYNAMIC</b>						
$t_{ON}$	Turnon time	$V_{COM} = 2\text{ V}$ , $R_L = 300\ \Omega$ , $C_L = 35\text{ pF}$ , see <a href="#">Figure 9</a>	$V_{CC} = 2.5\text{ V}$ , $T_A = 25^\circ\text{C}$		18	ns
			$2.25\text{ V} \leq V_{CC} \leq 2.75\text{ V}$ , $-40^\circ\text{C} \leq T_A \leq 85^\circ\text{C}$		20	
$t_{OFF}$	Turnoff time	$V_{COM} = 2\text{ V}$ , $R_L = 300\ \Omega$ , $C_L = 35\text{ pF}$ , see <a href="#">Figure 9</a>	$V_{CC} = 2.5\text{ V}$ , $T_A = 25^\circ\text{C}$		8	ns
			$2.25\text{ V} \leq V_{CC} \leq 2.75\text{ V}$ , $-40^\circ\text{C} \leq T_A \leq 85^\circ\text{C}$		9.5	
$t_{BBM}$	Break-before-make time	$V_{NC} = V_{NO} = 2\text{ V}$ , $R_L = 300\ \Omega$ , $C_L = 35\text{ pF}$ , see <a href="#">Figure 10</a>	$T_A = 25^\circ\text{C}$	1		ns
			$-40^\circ\text{C} \leq T_A \leq 85^\circ\text{C}$	0.9		
$Q_C$	Charge injection	$V_{GEN} = 0$ , $R_{GEN} = 0$ , $C_L = 1\text{ nF}$ , see <a href="#">Figure 14</a>		4.5		pC
$C_{NC(OFF)}$ , $C_{NO(OFF)}$	NC, NO OFF capacitance	$V_{NC}$ or $V_{NO} = V_{CC}$ or GND, $f = 1\text{ MHz}$ , Switch OFF, see <a href="#">Figure 8</a>		3.5		pF
$C_{NC(ON)}$ , $C_{NO(ON)}$	NC, NO ON capacitance	$V_{NC}$ or $V_{NO} = V_{CC}$ or GND, $f = 1\text{ MHz}$ , Switch OFF, see <a href="#">Figure 8</a>		8.5		pF

(1) All unused digital inputs of the device must be held at  $V_{CC}$  or GND to ensure proper device operation. See [Implications of Slow or Floating CMOS Inputs](#) (SCBA004).

### Electrical Characteristics: 2.5-V Supply (continued)

$V_{CC} = 2.5\text{ V}$ ,  $T_A = 25^\circ\text{C}$  (unless otherwise noted)

PARAMETER	TEST CONDITIONS	MIN	TYP	MAX	UNIT
$C_{COM(ON)}$	COM ON capacitance $V_{COM} = V_{CC}$ or GND, $f = 1\text{ MHz}$ , Switch OFF, see Figure 8		8.5		pF
$C_i$	Digital input capacitance $V_i = V_{CC}$ or GND, $f = 1\text{ MHz}$ , see Figure 8		2.5		pF
BW	Bandwidth $R_L = 50\ \Omega$ , Switch ON, see Figure 11		100		MHz
$O_{ISO}$	OFF isolation $R_L = 50\ \Omega$ , $f = 1\text{ MHz}$ , Switch OFF, see Figure 12		-84		dB
$X_{TALK}$	Crosstalk $R_L = 50\ \Omega$ , $f = 1\text{ MHz}$ , Switch ON, see Figure 13		-84		dB
THD	Total harmonic distortion $R_L = 600\ \Omega$ , $C_L = 50\text{ pF}$ , $f = 20\text{ Hz}$ to $20\text{ kHz}$ , see Figure 15		0.15%		
<b>SUPPLY</b>					
$I_{CC}$	Positive supply current $V_i = V_{CC}$ or GND, $V_{CC} = 2.75\text{ V}$ , Switch ON or OFF		$T_A = 25^\circ\text{C}$ 0.01 $-40^\circ\text{C} \leq T_A \leq 85^\circ\text{C}$		$\mu\text{A}$
				0.5	

### 6.8 Typical Characteristics

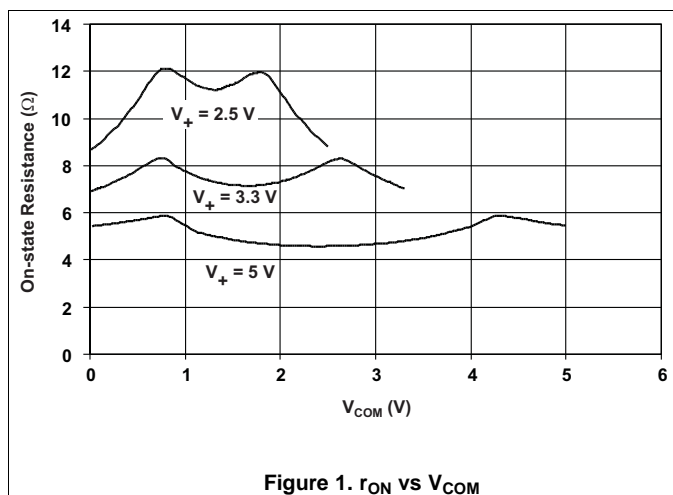

Figure 1.  $r_{ON}$  vs  $V_{COM}$

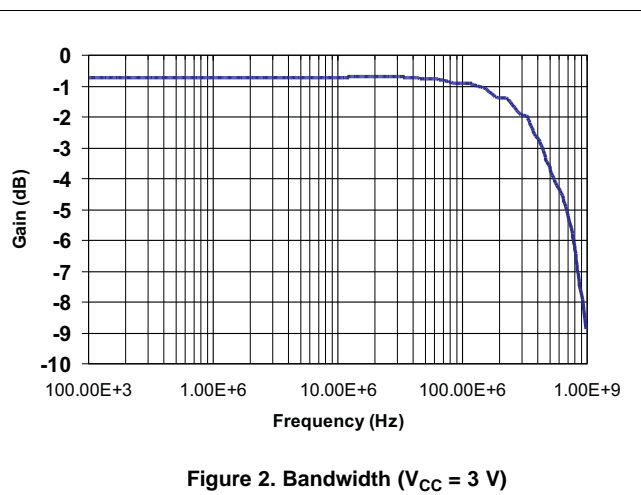

Figure 2. Bandwidth ( $V_{CC} = 3\text{ V}$ )

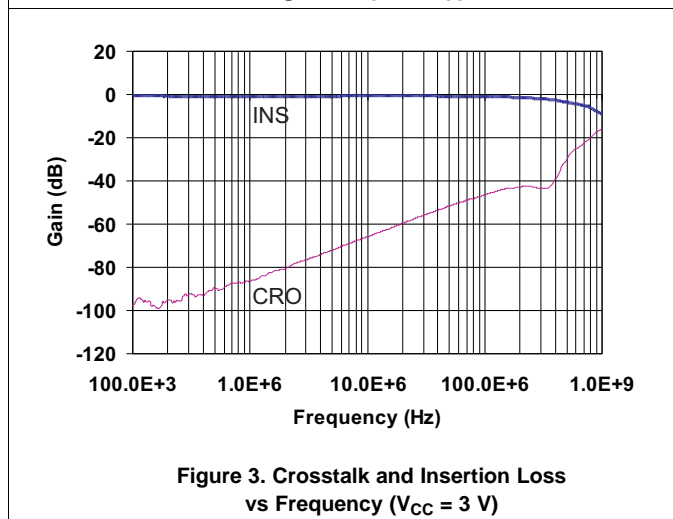

Figure 3. Crosstalk and Insertion Loss vs Frequency ( $V_{CC} = 3\text{ V}$ )

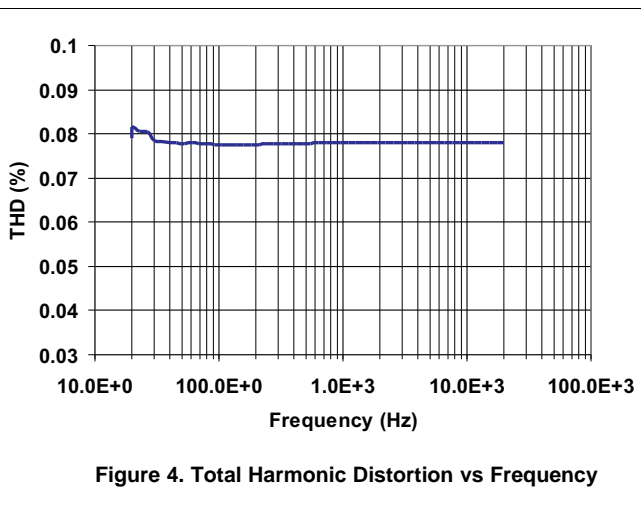

Figure 4. Total Harmonic Distortion vs Frequency

## 7 Parameter Measurement Information

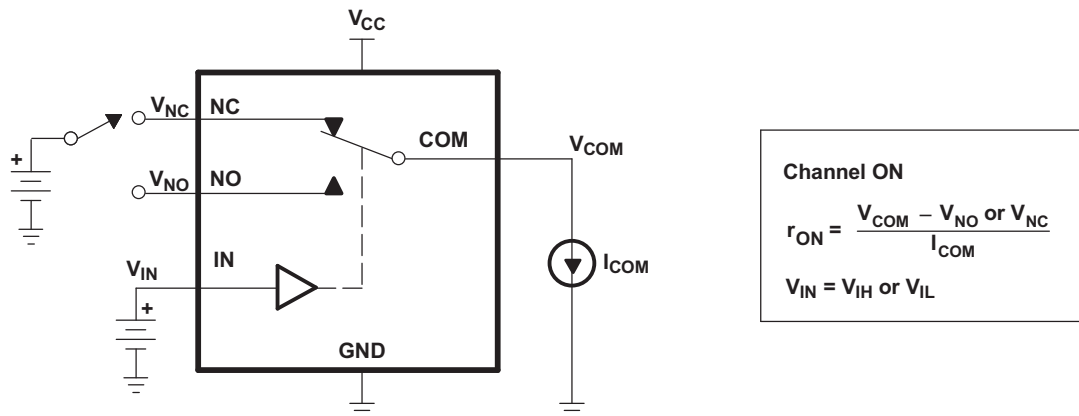

Figure 5. ON-State Resistance

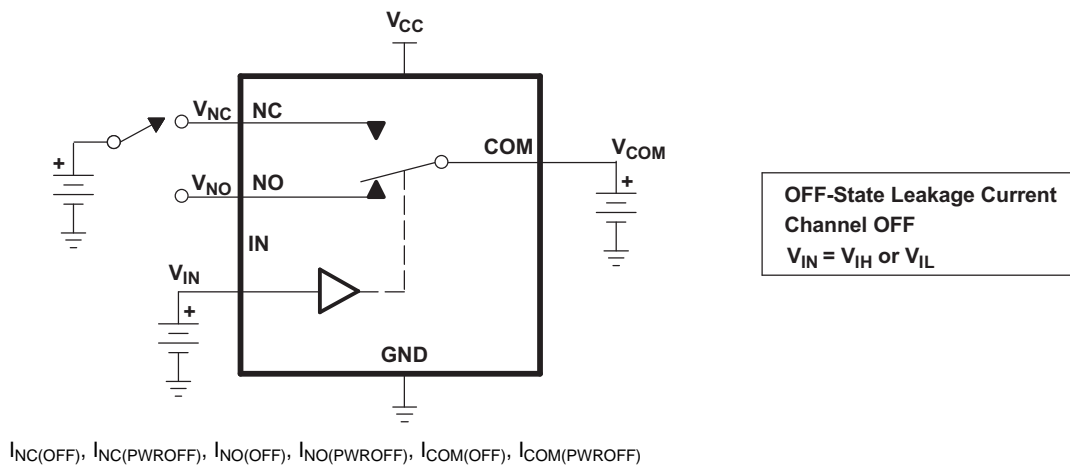

Figure 6. OFF-State Leakage Current

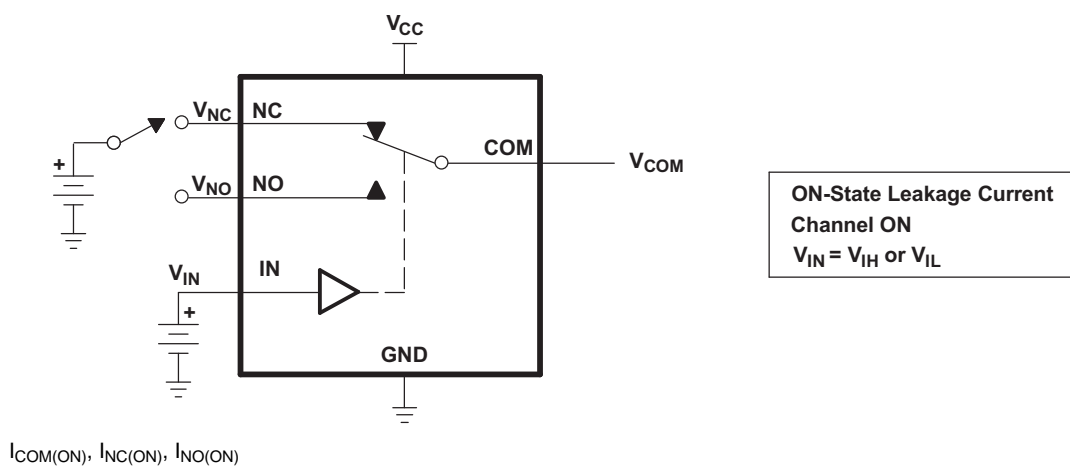
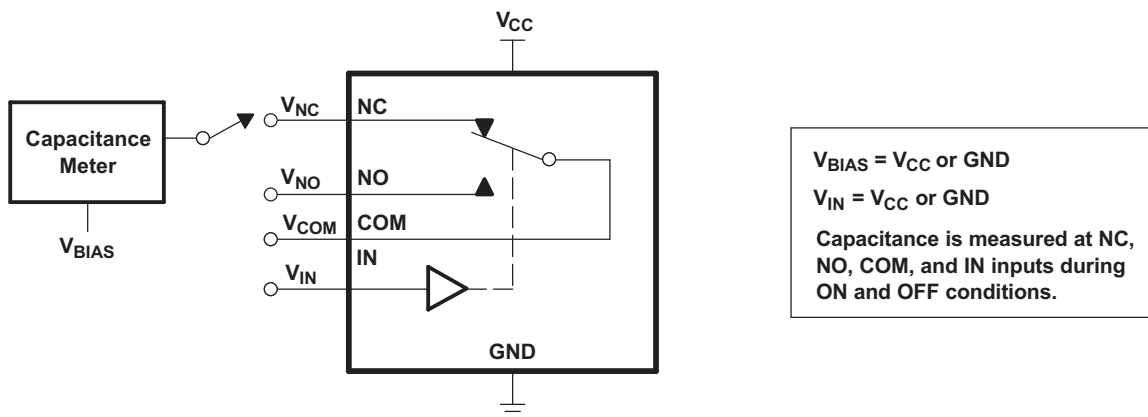

Figure 7. ON-State Leakage Current

Parameter Measurement Information (continued)



$C_I, C_{COM(ON)}, C_{NC(OFF)}, C_{NO(OFF)}, C_{NC(ON)}, C_{NO(ON)}$

Figure 8. Capacitance

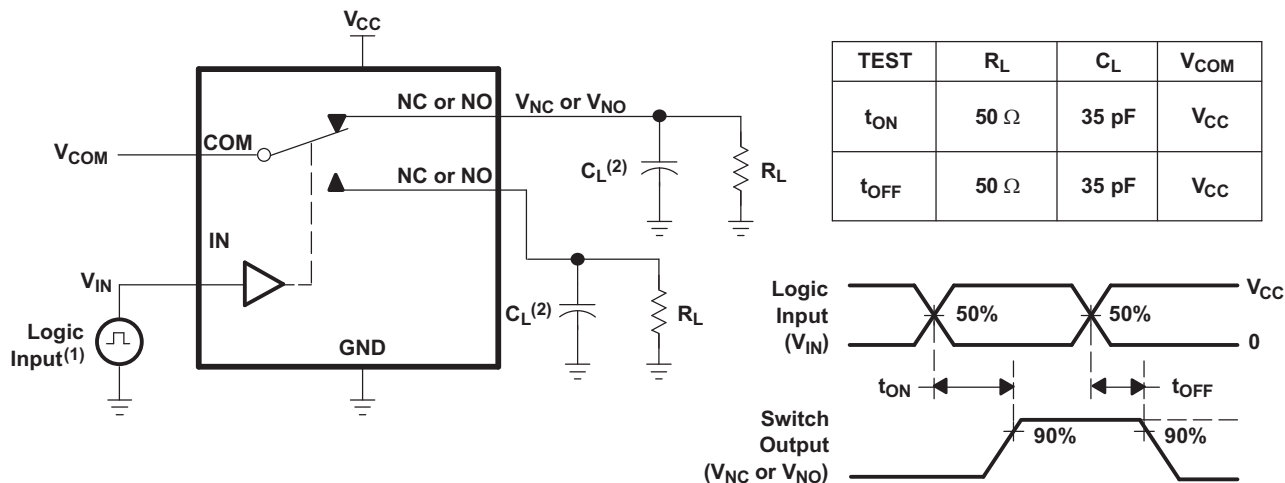

(1) All input pulses are supplied by generators having the following characteristics:

- $PRR \leq 10 \text{ MHz}$
- $Z_O = 50 \Omega$
- $t_r < 5 \text{ ns}$
- $t_f < 5 \text{ ns}$

(2)  $C_L$  includes probe and jig capacitance.

Figure 9. Turnon and Turnoff Time

**Parameter Measurement Information (continued)**

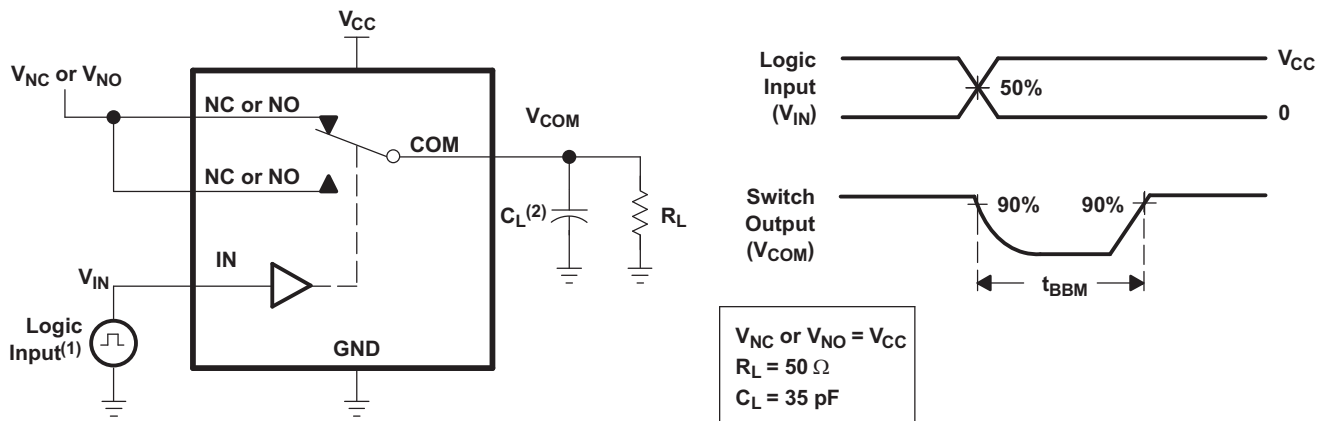

- (1) All input pulses are supplied by generators having the following characteristics:
- PRR  $\leq$  10 MHz
  - $Z_O = 50 \Omega$
  - $t_r < 5$  ns
  - $t_f < 5$  ns
- (2)  $C_L$  includes probe and jig capacitance.

**Figure 10. Break-Before-Make Time**

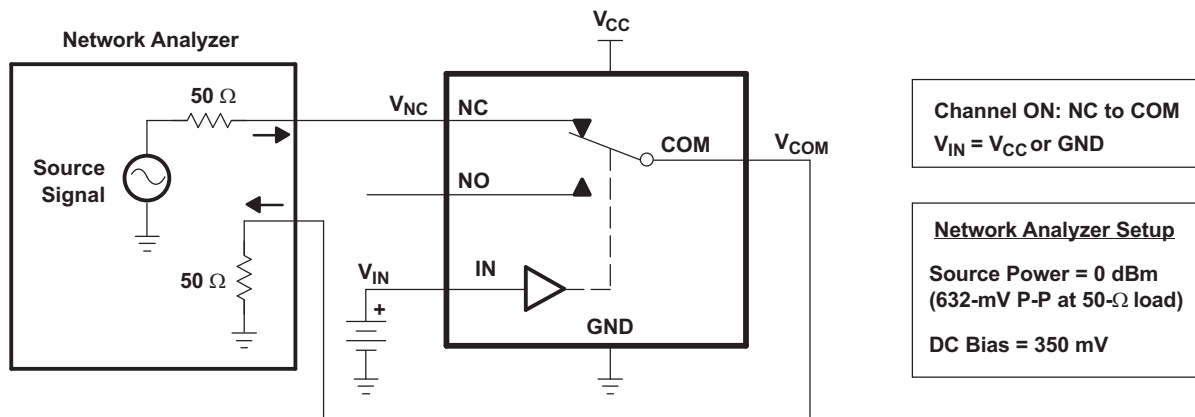

**Figure 11. Bandwidth**

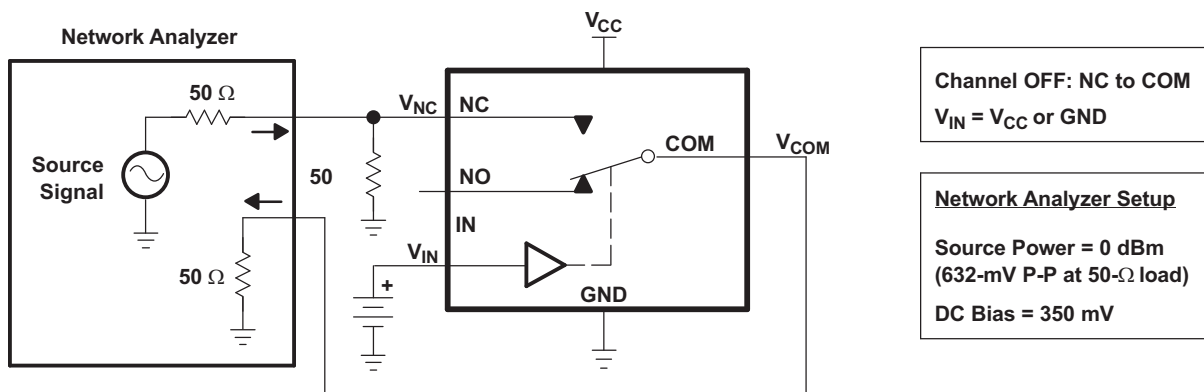

**Figure 12. OFF Isolation**

Parameter Measurement Information (continued)

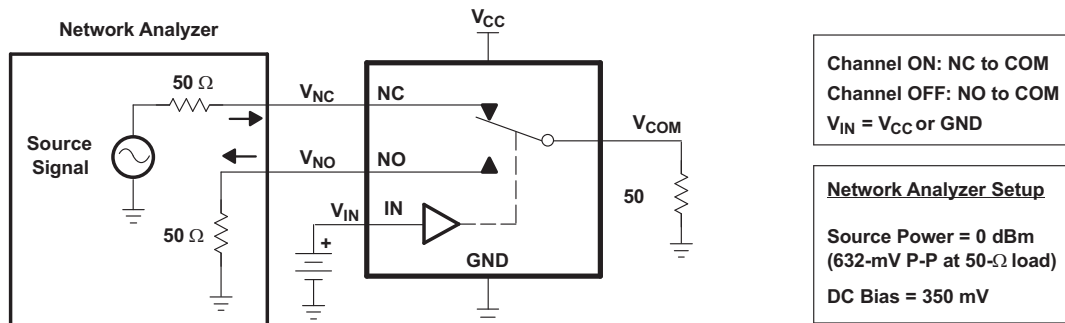
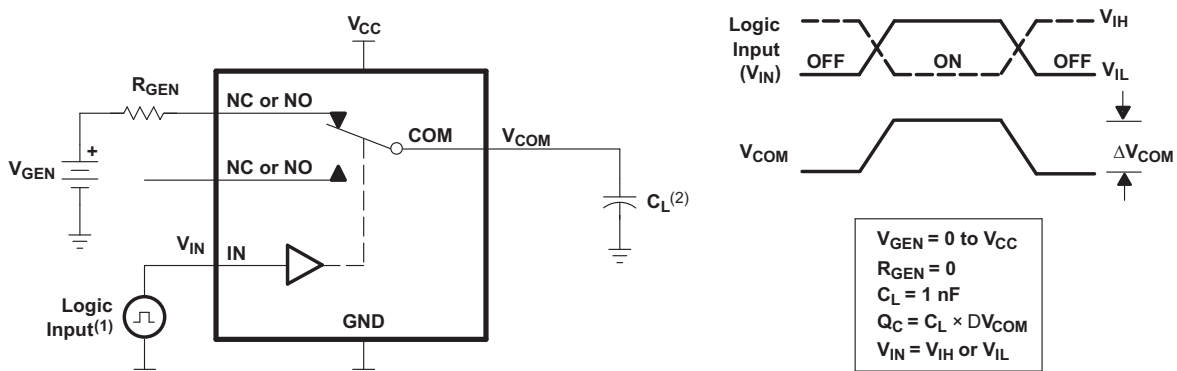
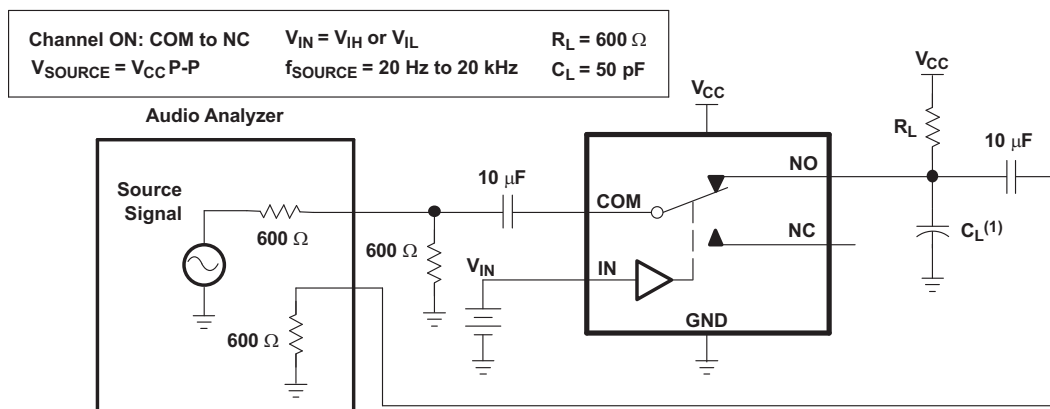

Figure 13. Crosstalk



- (1) All input pulses are supplied by generators having the following characteristics:
- PRR  $\leq$  10 MHz
  - $Z_O = 50 \Omega$
  - $t_r < 5$  ns
  - $t_f < 5$  ns
- (2)  $C_L$  includes probe and jig capacitance.

Figure 14. Charge Injection



- (1)  $C_L$  includes probe and jig capacitance.

Figure 15. Total Harmonic Distortion

## 8 Detailed Description

### 8.1 Overview

The TS5A9411 device is a 1:2 or single-pole-double-throw (SPDT) solid-state analog switch. The TS5A9411, like all analog switches, is bidirectional. When powered on, each COM pin is connected to the NC pin or NO pin depending on the status of the IN pin. If IN is low, COM is connected to NC. If IN is high, COM is connected to NO. The TS5A9411 is a break-before-make switch. This means that during switching, a connection is broken before a new connection is established. The NC and NO pins are never connected to each other.

### 8.2 Functional Block Diagram

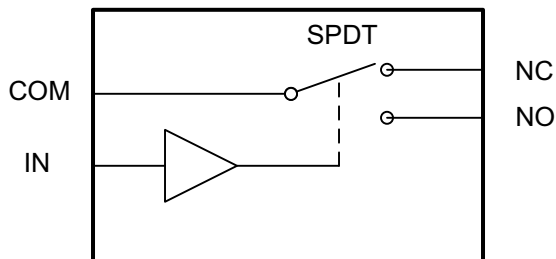

### 8.3 Feature Description

The low ON-state resistance, ON-state resistance matching, and charge injection in the TS5A9411 make this switch an excellent choice for analog signals that require minimal distortion. The 2.25-V to 5.5-V operation allows compatibility with more voltage nodes, and the bidirectional I/Os can pass analog signals from 0 V to  $V_{CC}$  with low distortion.

### 8.4 Device Functional Modes

Table 1 lists the functional modes of the TS5A9411. If IN pin is low, COM is connected to NC. If IN is high, COM is connected to NO.

Table 1. Function Table

IN	NC TO COM, COM TO NC	NO TO COM, COM TO NO
L	ON	OFF
H	OFF	ON

## 9 Application and Implementation

### NOTE

Information in the following applications sections is not part of the TI component specification, and TI does not warrant its accuracy or completeness. TI's customers are responsible for determining suitability of components for their purposes. Customers should validate and test their design implementation to confirm system functionality.

### 9.1 Application Information

The switches are bidirectional, so the NO, NC, and COM pins can be used as either inputs or outputs. The device is used in systems where multiple analog or digital signals must be selected to pass across a single line.

### 9.2 Typical Application

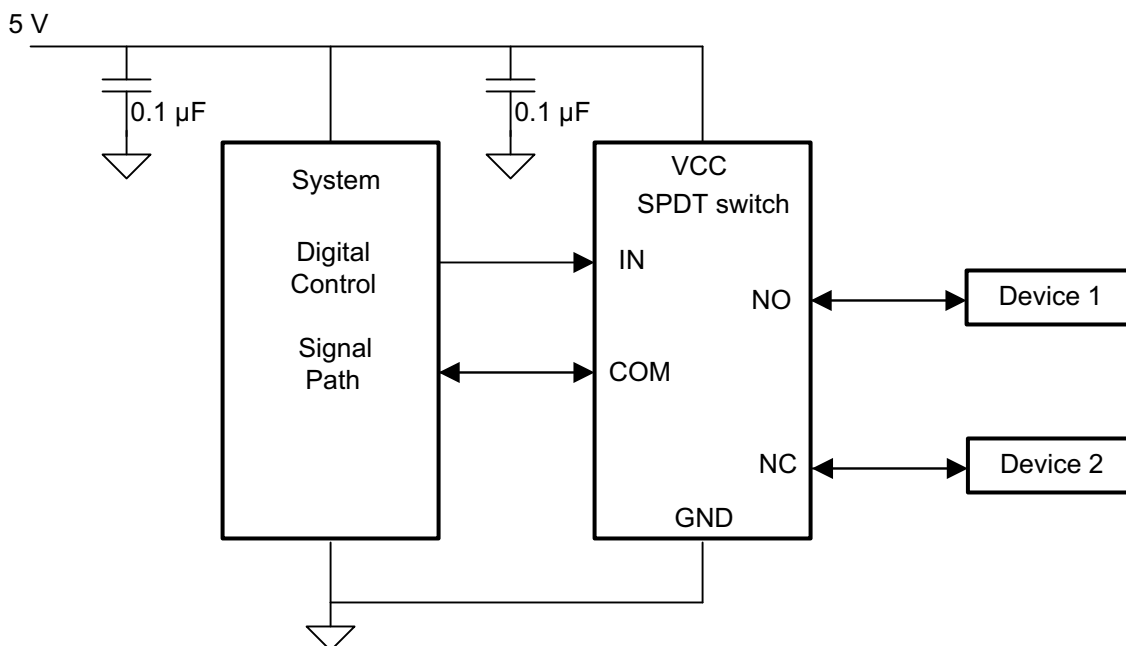

Figure 16. Typical Application Diagram

#### 9.2.1 Design Requirements

Pull the digitally controlled input select pin (IN) to  $V_{CC}$  or GND to avoid unwanted switch states that could result if the logic control pin is left floating.

#### 9.2.2 Detailed Design Procedure

Select the appropriate supply voltage to cover the entire voltage swing of the signal passing through the switch because the input or output signal swing of the device is dependant of the supply voltage ( $V_{CC}$ ).

## Typical Application (continued)

### 9.2.3 Application Curve

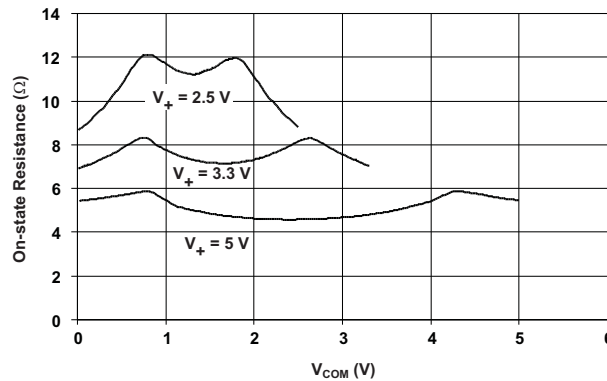

Figure 17. r<sub>ON</sub> vs V<sub>COM</sub>

## 10 Power Supply Recommendations

Proper power-supply sequencing is recommended for all CMOS devices. Do not exceed the absolute maximum ratings, because stresses beyond the listed ratings can cause permanent damage to the device. Always sequence V<sub>CC</sub> on first, followed by NO, NC, or COM pins.

Although it is not required, power-supply bypassing improves noise margin and prevents switching noise propagation from the V<sub>CC</sub> supply to other components. A 0.1-μF capacitor, connected from V<sub>CC</sub> to GND, is adequate for most applications.

## 11 Layout

### 11.1 Layout Guidelines

TI recommends placing a bypass capacitor as close to the supply pins (V<sub>CC</sub> and –V<sub>CC</sub>) as possible to help smooth out lower frequency noise to provide better load regulation across the frequency spectrum. Minimize trace lengths and vias on the signal paths to preserve signal integrity.

### 11.2 Layout Example

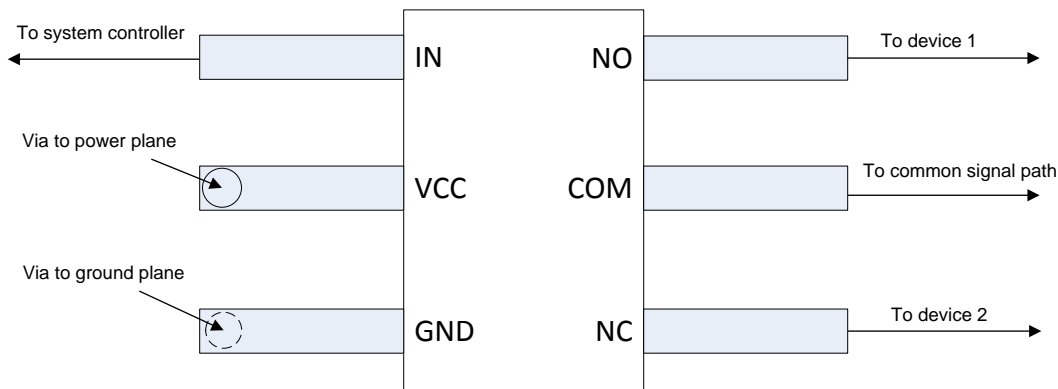

Figure 18. Layout Recommendation

## 12 Device and Documentation Support

### 12.1 Device Support

#### 12.1.1 Device Nomenclature

<b>BW</b>	Bandwidth of the switch. This is the frequency in which the gain of an ON channel is –3 dB below the DC gain.
<b>C<sub>COM(ON)</sub></b>	Capacitance at the COM port when the corresponding channel (COM to NC or COM to NO) is ON.
<b>C<sub>NC(OFF)</sub></b>	Capacitance at the NC port when the corresponding channel (NC to COM) is OFF.
<b>C<sub>NC(ON)</sub></b>	Capacitance at the NC port when the corresponding channel (NC to COM) is ON.
<b>C<sub>NO(OFF)</sub></b>	Capacitance at the NO port when the corresponding channel (NO to COM) is OFF.
<b>C<sub>NO(ON)</sub></b>	Capacitance at the NO port when the corresponding channel (NO to COM) is ON.
<b>C<sub>I</sub></b>	Capacitance of control input (IN).
<b>I<sub>CC</sub></b>	Static power-supply current with the control (IN) pin at V <sub>CC</sub> or GND.
<b>I<sub>COM(ON)</sub></b>	Leakage current measured at the COM port, with the corresponding channel (COM to NO or COM to NC) in the ON state and the output (NC or NO) open.
<b>I<sub>COM(PWROFF)</sub></b>	Leakage current measured at the COM port during the power-down condition (V <sub>CC</sub> = 0).
<b>I<sub>IH</sub>, I<sub>IL</sub></b>	Leakage current measured at the control input (IN).
<b>I<sub>NC(OFF)</sub></b>	Leakage current measured at the NC port, with the corresponding channel (NC to COM) in the OFF state under worst-case input and output conditions.
<b>I<sub>NC(ON)</sub></b>	Leakage current measured at the NC port, with the corresponding channel (NC to COM) in the ON state and the output (COM) open.
<b>I<sub>NO(OFF)</sub></b>	Leakage current measured at the NO port, with the corresponding channel (NO to COM) in the OFF state under worst-case input and output conditions.
<b>I<sub>NO(ON)</sub></b>	Leakage current measured at the NO port, with the corresponding channel (NO to COM) in the ON state and the output (COM) open.
<b>O<sub>ISO</sub></b>	OFF isolation of the switch is a measurement of OFF-state switch impedence. This is measured in dB in a specific frequency, with the corresponding channel (NC to COM or NO to COM) in the OFF state.
<b>Q<sub>C</sub></b>	Charge injection is a measurement of unwanted signal coupling from the control (IN) input to the analog (NC, NO, or COM) output. This is measured in coulomb (C) and measured by the total charge induced due to switching of the control input. Charge injection, $Q_C = C_L \times \Delta V_{COM}$ , C <sub>L</sub> is the load capacitance and $\Delta V_{COM}$ is the change in analog output voltage.
<b>Δr<sub>ON</sub></b>	Difference of r <sub>ON</sub> between channels in a specific device.
<b>r<sub>ON</sub></b>	Resistance between COM and NC or COM and NO ports when the channel is ON.
<b>r<sub>ON(FLAT)</sub></b>	Difference of r <sub>ON</sub> in a channel over the specified range of conditions.
<b>t<sub>BBM</sub></b>	Break-before-make time. This parameter is measured under the specified range of conditions and by the propagation delay between the output of two adjacent analog channels (NC and NO) when the control signal changes state.
<b>t<sub>OFF</sub></b>	Turnoff time for the switch. This parameter is measured under the specified range of conditions and by the propagation delay between the digital control (IN) signal and analog output (COM, NC, or NO) signal when the switch is turning OFF.
<b>t<sub>ON</sub></b>	Turnon time for the switch. This parameter is measured under the specified range of conditions and by the propagation delay between the digital control (IN) signal and analog output (COM, NC, or NO) signal when the switch is turning ON.
<b>THD</b>	Total harmonic distortion describes the signal distortion caused by the analog switch. This is

## Device Support (continued)

defined as the ratio of root mean square (RMS) value of the second, third, and higher harmonic to the absolute magnitude of the fundamental harmonic.

$V_{COM}$	Voltage at COM.
$V_I$	Voltage at the control input (IN).
$V_{IH}$	Minimum input voltage for logic high for the control input (IN).
$V_{IL}$	Maximum input voltage for logic low for the control input (IN).
$V_{NC}$	Voltage at NC.
$V_{NO}$	Voltage at NO.
$X_{TALK}$	Crosstalk is a measurement of unwanted signal coupling from an ON channel to an OFF channel (NC to NO or NO to NC). This is measured in a specific frequency and in dB.

## 12.2 Documentation Support

### 12.2.1 Related Documentation

For related documentation see the following:

[Implications of Slow or Floating CMOS Inputs](#) (SCBA004)

## 12.3 Receiving Notification of Documentation Updates

To receive notification of documentation updates, navigate to the device product folder on ti.com. In the upper right corner, click on *Alert me* to register and receive a weekly digest of any product information that has changed. For change details, review the revision history included in any revised document.

## 12.4 Community Resources

The following links connect to TI community resources. Linked contents are provided "AS IS" by the respective contributors. They do not constitute TI specifications and do not necessarily reflect TI's views; see TI's [Terms of Use](#).

**TI E2E™ Online Community** *TI's Engineer-to-Engineer (E2E) Community*. Created to foster collaboration among engineers. At e2e.ti.com, you can ask questions, share knowledge, explore ideas and help solve problems with fellow engineers.

**Design Support** *TI's Design Support* Quickly find helpful E2E forums along with design support tools and contact information for technical support.

## 12.5 Trademarks

E2E is a trademark of Texas Instruments.  
All other trademarks are the property of their respective owners.

## 12.6 Electrostatic Discharge Caution



This integrated circuit can be damaged by ESD. Texas Instruments recommends that all integrated circuits be handled with appropriate precautions. Failure to observe proper handling and installation procedures can cause damage.

ESD damage can range from subtle performance degradation to complete device failure. Precision integrated circuits may be more susceptible to damage because very small parametric changes could cause the device not to meet its published specifications.

## 12.7 Glossary



**SLYZ022** — *TI Glossary*.

This glossary lists and explains terms, acronyms, and definitions.

### **13 Mechanical, Packaging, and Orderable Information**

The following pages include mechanical, packaging, and orderable information. This information is the most current data available for the designated devices. This data is subject to change without notice and revision of this document. For browser-based versions of this data sheet, refer to the left-hand navigation.

**PACKAGING INFORMATION**

Orderable Device	Status (1)	Package Type	Package Drawing	Pins	Package Qty	Eco Plan (2)	Lead finish/ Ball material (6)	MSL Peak Temp (3)	Op Temp (°C)	Device Marking (4/5)	Samples
TS5A9411DCKR	ACTIVE	SC70	DCK	6	3000	RoHS & Green	NIPDAU	Level-1-260C-UNLIM	-40 to 85	(32F, 32R) (32H, 32P)	
TS5A9411DCKT	ACTIVE	SC70	DCK	6	250	RoHS & Green	NIPDAU	Level-1-260C-UNLIM	-40 to 85	(32F, 32R) 32H	
TS5A9411DCKTG4	ACTIVE	SC70	DCK	6	250	RoHS & Green	NIPDAU	Level-1-260C-UNLIM	-40 to 85	(32F, 32R) 32H	

(1) The marketing status values are defined as follows:

**ACTIVE:** Product device recommended for new designs.

**LIFEBUY:** TI has announced that the device will be discontinued, and a lifetime-buy period is in effect.

**NRND:** Not recommended for new designs. Device is in production to support existing customers, but TI does not recommend using this part in a new design.

**PREVIEW:** Device has been announced but is not in production. Samples may or may not be available.

**OBSELETE:** TI has discontinued the production of the device.

(2) **RoHS:** TI defines "RoHS" to mean semiconductor products that are compliant with the current EU RoHS requirements for all 10 RoHS substances, including the requirement that RoHS substance do not exceed 0.1% by weight in homogeneous materials. Where designed to be soldered at high temperatures, "RoHS" products are suitable for use in specified lead-free processes. TI may reference these types of products as "Pb-Free".

**RoHS Exempt:** TI defines "RoHS Exempt" to mean products that contain lead but are compliant with EU RoHS pursuant to a specific EU RoHS exemption.

**Green:** TI defines "Green" to mean the content of Chlorine (Cl) and Bromine (Br) based flame retardants meet JS709B low halogen requirements of <=1000ppm threshold. Antimony trioxide based flame retardants must also meet the <=1000ppm threshold requirement.

(3) MSL, Peak Temp. - The Moisture Sensitivity Level rating according to the JEDEC industry standard classifications, and peak solder temperature.

(4) There may be additional marking, which relates to the logo, the lot trace code information, or the environmental category on the device.

(5) Multiple Device Markings will be inside parentheses. Only one Device Marking contained in parentheses and separated by a "~" will appear on a device. If a line is indented then it is a continuation of the previous line and the two combined represent the entire Device Marking for that device.

(6) Lead finish/Ball material - Orderable Devices may have multiple material finish options. Finish options are separated by a vertical ruled line. Lead finish/Ball material values may wrap to two lines if the finish value exceeds the maximum column width.

**Important Information and Disclaimer:**The information provided on this page represents TI's knowledge and belief as of the date that it is provided. TI bases its knowledge and belief on information provided by third parties, and makes no representation or warranty as to the accuracy of such information. Efforts are underway to better integrate information from third parties. TI has taken and continues to take reasonable steps to provide representative and accurate information but may not have conducted destructive testing or chemical analysis on incoming materials and chemicals. TI and TI suppliers consider certain information to be proprietary, and thus CAS numbers and other limited information may not be available for release.

In no event shall TI's liability arising out of such information exceed the total purchase price of the TI part(s) at issue in this document sold by TI to Customer on an annual basis.

## TAPE AND REEL INFORMATION



### QUADRANT ASSIGNMENTS FOR PIN 1 ORIENTATION IN TAPE



\*All dimensions are nominal

Device	Package Type	Package Drawing	Pins	SPQ	Reel Diameter (mm)	Reel Width W1 (mm)	A0 (mm)	B0 (mm)	K0 (mm)	P1 (mm)	W (mm)	Pin1 Quadrant
TS5A9411DCKR	SC70	DCK	6	3000	180.0	8.4	2.41	2.41	1.2	4.0	8.0	Q3
TS5A9411DCKT	SC70	DCK	6	250	180.0	8.4	2.41	2.41	1.2	4.0	8.0	Q3

**TAPE AND REEL BOX DIMENSIONS**

\*All dimensions are nominal

Device	Package Type	Package Drawing	Pins	SPQ	Length (mm)	Width (mm)	Height (mm)
TS5A9411DCKR	SC70	DCK	6	3000	202.0	201.0	28.0
TS5A9411DCKT	SC70	DCK	6	250	202.0	201.0	28.0

DCK (R-PDSO-G6)

PLASTIC SMALL-OUTLINE PACKAGE

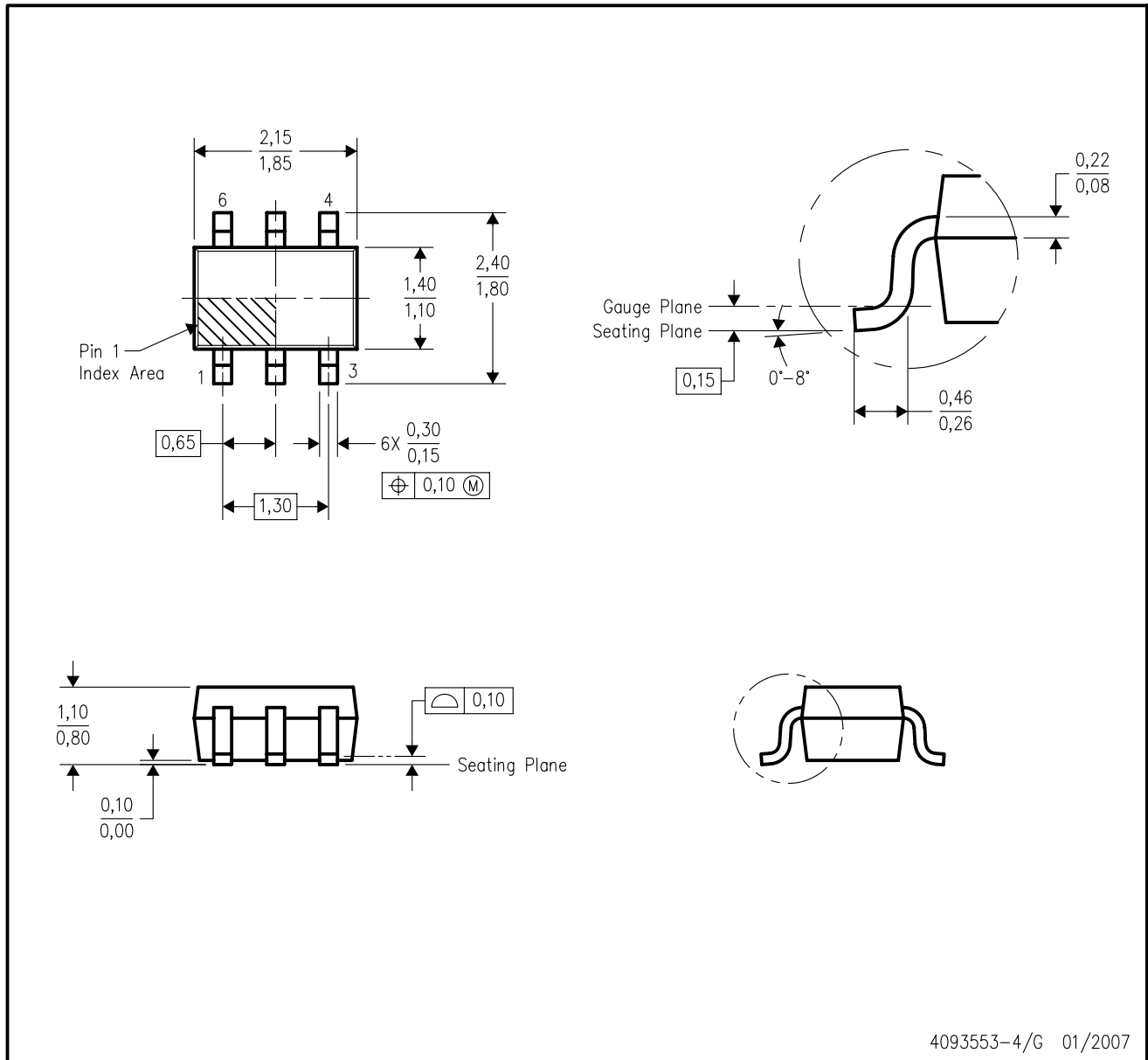

- NOTES:
- A. All linear dimensions are in millimeters.
  - B. This drawing is subject to change without notice.
  - C. Body dimensions do not include mold flash or protrusion. Mold flash and protrusion shall not exceed 0.15 per side.
  - D. Falls within JEDEC MO-203 variation AB.

DCK (R-PDSO-G6)

PLASTIC SMALL OUTLINE

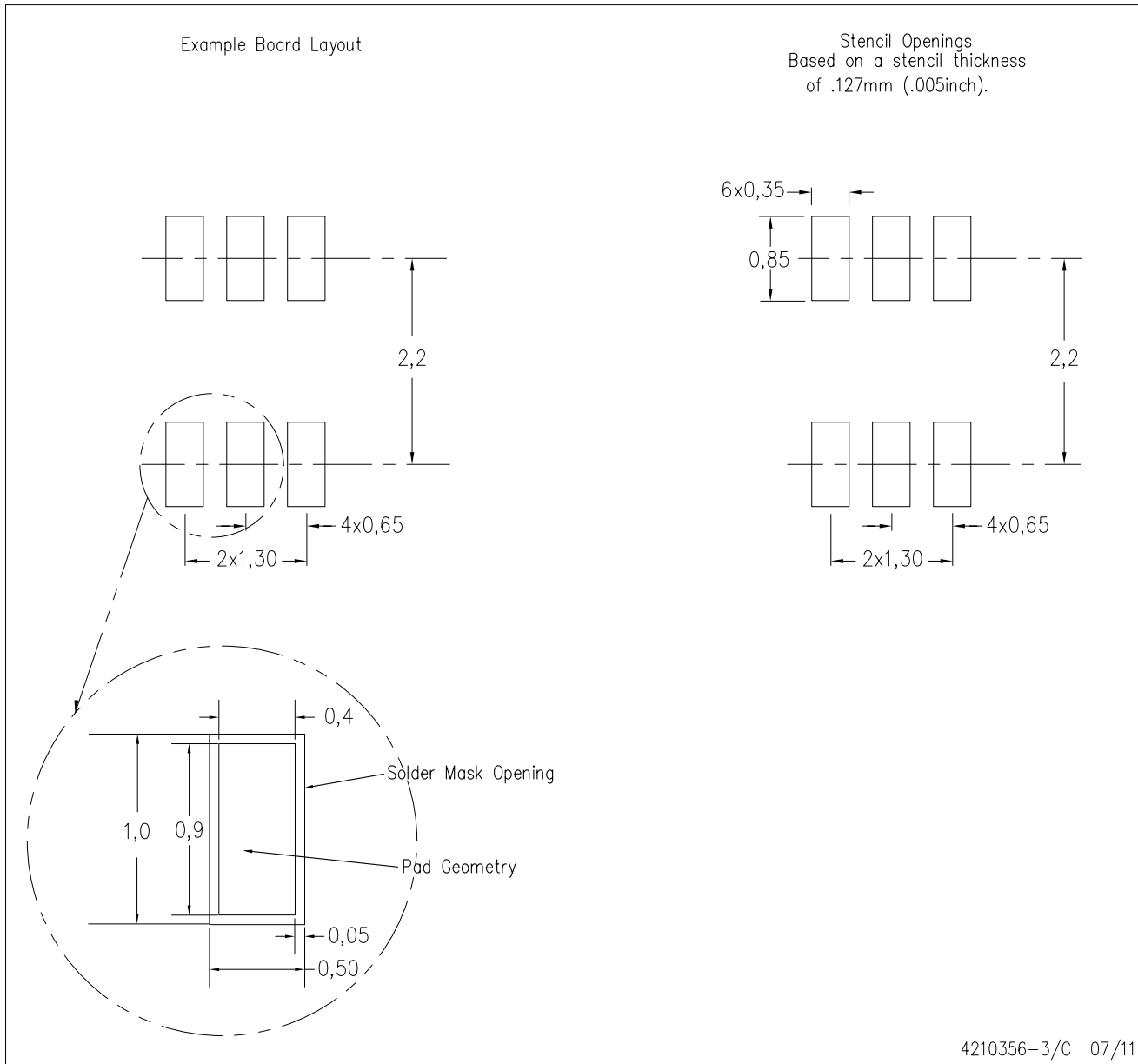

- NOTES:
- A. All linear dimensions are in millimeters.
  - B. This drawing is subject to change without notice.
  - C. Customers should place a note on the circuit board fabrication drawing not to alter the center solder mask defined pad.
  - D. Publication IPC-7351 is recommended for alternate designs.
  - E. Laser cutting apertures with trapezoidal walls and also rounding corners will offer better paste release. Customers should contact their board assembly site for stencil design recommendations. Example stencil design based on a 50% volumetric metal load solder paste. Refer to IPC-7525 for other stencil recommendations.

## IMPORTANT NOTICE AND DISCLAIMER

TI PROVIDES TECHNICAL AND RELIABILITY DATA (INCLUDING DATASHEETS), DESIGN RESOURCES (INCLUDING REFERENCE DESIGNS), APPLICATION OR OTHER DESIGN ADVICE, WEB TOOLS, SAFETY INFORMATION, AND OTHER RESOURCES "AS IS" AND WITH ALL FAULTS, AND DISCLAIMS ALL WARRANTIES, EXPRESS AND IMPLIED, INCLUDING WITHOUT LIMITATION ANY IMPLIED WARRANTIES OF MERCHANTABILITY, FITNESS FOR A PARTICULAR PURPOSE OR NON-INFRINGEMENT OF THIRD PARTY INTELLECTUAL PROPERTY RIGHTS.

These resources are intended for skilled developers designing with TI products. You are solely responsible for (1) selecting the appropriate TI products for your application, (2) designing, validating and testing your application, and (3) ensuring your application meets applicable standards, and any other safety, security, or other requirements. These resources are subject to change without notice. TI grants you permission to use these resources only for development of an application that uses the TI products described in the resource. Other reproduction and display of these resources is prohibited. No license is granted to any other TI intellectual property right or to any third party intellectual property right. TI disclaims responsibility for, and you will fully indemnify TI and its representatives against, any claims, damages, costs, losses, and liabilities arising out of your use of these resources.

TI's products are provided subject to TI's Terms of Sale ([www.ti.com/legal/termsofsale.html](http://www.ti.com/legal/termsofsale.html)) or other applicable terms available either on [ti.com](http://ti.com) or provided in conjunction with such TI products. TI's provision of these resources does not expand or otherwise alter TI's applicable warranties or warranty disclaimers for TI products.

Mailing Address: Texas Instruments, Post Office Box 655303, Dallas, Texas 75265  
Copyright © 2020, Texas Instruments Incorporated